

# Uncertainty Analysis for Four Terminal-Pair Capacitance and Dissipation Factor Characterization at 1 and 10 MHz

Andrew D. Koffman, *Member, IEEE*, Svetlana Avramov-Zamurovic, Bryan Cristopher Waltrip, *Member, IEEE*, and Nile M. Oldham, *Fellow, IEEE*

**Abstract**—The Electricity Division at the National Institute of Standards and Technology (NIST, formerly NBS) has developed the capability to characterize capacitance and dissipation factor for four terminal-pair (4TP) air dielectric capacitors at frequencies from 1 kHz to 10 MHz. The method, based on work by Cutkosky and Jones of NBS and recent developments by Hewlett-Packard Japan, involves single-port network analyzer impedance measurements at frequencies from 40 MHz to 200 MHz and capacitance measurements using a precision 1 kHz capacitance meter. A mathematical regression algorithm is used to extrapolate inductance and resistance measurements from the network analyzer down to 1 kHz in order to predict capacitance and dissipation factor from 1 kHz to 10 MHz. A comprehensive uncertainty analysis for the procedure is presented.

**Index Terms**—Capacitance, dissipation factor, four terminal pair, impedance, precision measurements, uncertainty analysis.

## I. INTRODUCTION

THE Electricity Division at the National Institute of Standards and Technology (NIST, formerly NBS) has implemented a system to characterize capacitance and dissipation factor for four terminal-pair (4TP) air dielectric capacitors at frequencies from 1 kHz to 10 MHz [1]. The method is based on work by Cutkosky [2], [3] and Jones [4], [5] of NBS and recent developments by Yokoi *et al.* [6], [7] as well as Yonekura and Wakasugi [8] of Hewlett-Packard Japan. This paper describes an extensive uncertainty analysis of the measurement system. The analysis has been divided into three areas: 1-kHz capacitance measurements; network analyzer impedance measurements (covering frequencies from 40 to 200 MHz); and a mathematical extrapolation algorithm that regresses the high-frequency characterization down to frequencies of 10 MHz and below [6], [7]. This algorithm is referred to as the capacitor frequency characteristic prediction (CFCP) method. The capacitance and dissipation factor characteristics at 1 and 10 MHz are produced by applying the CFCP algorithm to the 1-kHz capacitance as well as the high-frequency (40–200 MHz) impedance measurements.

Manuscript received May 26, 1999; revised December 1, 1999.

A. D. Koffman, B. Waltrip, and N. M. Oldham are with the Electricity Division, National Institute of Standards and Technology, Gaithersburg, MD 20899-8111 USA.

S. Avramov-Zamurovic is with the U.S. Naval Academy, Systems Engineering Department, Annapolis, MD 21402 USA.

Publisher Item Identifier S 0018-9456(00)03058-8.

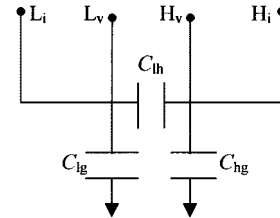

Fig. 1. Four terminal-pair capacitor: simple model.

TABLE I  
TYPE A STANDARD UNCERTAINTIES FOR  
1-KHz MEASUREMENTS

Nominal Capacitance (pF)	Measured Parameter	Measured Capacitance (pF)	Type A Uncertainty (ppm)
1	C <sub>lh</sub>	1.0000142	5
	C <sub>lg</sub>	48.82658	37
	C <sub>hg</sub>	17.67269	86
10	C <sub>lh</sub>	10.000745	4
	C <sub>lg</sub>	29.16876	14
	C <sub>hg</sub>	25.02418	30
100	C <sub>lh</sub>	99.99892	7
	C <sub>lg</sub>	32.27685	30
	C <sub>hg</sub>	31.03866	37
1000	C <sub>lh</sub>	1000.0739	5
	C <sub>lg</sub>	34.98904	164
	C <sub>hg</sub>	33.36330	263

Capacitors characterized using this technique will be used as impedance reference standards for a general-purpose digital impedance bridge recently developed at NIST to calibrate inductors and ac resistors [9]. The technique is also to be employed in a future NIST special test for 4TP capacitance and dissipation factor.

## II. 1-KHz CAPACITANCE MEASUREMENT UNCERTAINTY

Fig. 1 shows the simple 4TP capacitor circuit model, where  $C_{lh}$  is the low-to-high capacitance and  $C_{lg}$  and  $C_{hg}$  are low-to-ground and high-to-ground leakage capacitances, respectively. These capacitance components are repeatedly measured over time to establish repeatability using a 1-kHz capacitance meter. Table I presents Type A relative standard uncertainties for 1-kHz measurements of the 1-, 10-, 100-, and 1000-pF standard capacitors. Uncertainties are given as parts in  $10^6$  and labeled ppm. The Type B relative standard uncertainty for the 1-kHz capacitance meter is about 10 ppm [10].

# Report Documentation Page

*Form Approved*  
*OMB No. 0704-0188*

Public reporting burden for the collection of information is estimated to average 1 hour per response, including the time for reviewing instructions, searching existing data sources, gathering and maintaining the data needed, and completing and reviewing the collection of information. Send comments regarding this burden estimate or any other aspect of this collection of information, including suggestions for reducing this burden, to Washington Headquarters Services, Directorate for Information Operations and Reports, 1215 Jefferson Davis Highway, Suite 1204, Arlington VA 22202-4302. Respondents should be aware that notwithstanding any other provision of law, no person shall be subject to a penalty for failing to comply with a collection of information if it does not display a currently valid OMB control number.

1. REPORT DATE <b>DEC 1999</b>		2. REPORT TYPE		3. DATES COVERED <b>00-00-1999 to 00-00-1999</b>	
4. TITLE AND SUBTITLE <b>Uncertainty Analysis for Four Terminal-Pair Capacitance and Dissipation Factor Characterization at 1 and 10 MHz</b>				5a. CONTRACT NUMBER	
				5b. GRANT NUMBER	
				5c. PROGRAM ELEMENT NUMBER	
6. AUTHOR(S)				5d. PROJECT NUMBER	
				5e. TASK NUMBER	
				5f. WORK UNIT NUMBER	
7. PERFORMING ORGANIZATION NAME(S) AND ADDRESS(ES) <b>United States Naval Academy, Department of Systems Engineering, Annapolis, MD, 21402</b>				8. PERFORMING ORGANIZATION REPORT NUMBER	
9. SPONSORING/MONITORING AGENCY NAME(S) AND ADDRESS(ES)				10. SPONSOR/MONITOR'S ACRONYM(S)	
				11. SPONSOR/MONITOR'S REPORT NUMBER(S)	
12. DISTRIBUTION/AVAILABILITY STATEMENT <b>Approved for public release; distribution unlimited</b>					
13. SUPPLEMENTARY NOTES					
14. ABSTRACT <b>The Electricity Division at the National Institute of Standards and Technology (NIST, formerly NBS) has developed the capability to characterize capacitance and dissipation factor for four terminal-pair (4TP) air dielectric capacitors at frequencies from 1 kHz to 10 MHz. The method, based on work by Cutkosy and Jones of NBS and recent developments by Hewlett-Packard Japan involves single-port network analyzer impedance measurements at frequencies from 40 MHz to 200 MHz and capacitance measurements using a precision 1 kHz capacitance meter. A mathematical regression algorithm is used to extrapolate inductance and resistance measurements from the network analyzer down to 1 kHz in order to predict capacitance and dissipation factor from 1 kHz to 10 MHz. A comprehensive uncertainty analysis for the procedure is presented.</b>					
15. SUBJECT TERMS					
16. SECURITY CLASSIFICATION OF:			17. LIMITATION OF ABSTRACT	18. NUMBER OF PAGES	19a. NAME OF RESPONSIBLE PERSON
a. REPORT <b>unclassified</b>	b. ABSTRACT <b>unclassified</b>	c. THIS PAGE <b>unclassified</b>			

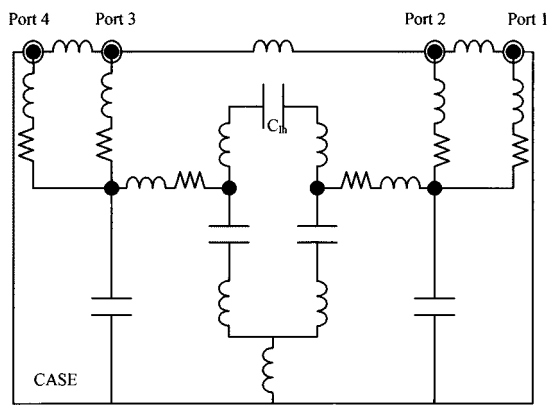

Fig. 2. Yonekura component model.

Since the results of the 1-kHz capacitance measurements are used in the CFCP method, there will be an uncertainty contribution from the 1-kHz measurements to the final capacitance and dissipation factor results. Software simulations were performed to determine the uncertainty components of the 4TP capacitance and dissipation factor due to the 1-kHz capacitance measurements.

In 1990, Yonekura and Wakasugi described a circuit model of 4TP capacitors (of the type described in this paper) [8]. They disassembled several of these capacitors and measured and published the values of typical model components, e.g., connector and lead inductances. The following simulations are based on this model and component values (see Fig. 2).

Equations were developed to describe the Yonekura model in terms of the model components. Using published values from [8], we computed the 4TP capacitance and dissipation, as well as the single-port data needed for the CFCP algorithm for this “reference” capacitor.

The sensitivity of the CFCP method was tested by applying a fixed set of single-port (simulated network analyzer) data, while randomly varying the 1-kHz capacitance data based on the values given in Table I. Predictions of the 4TP capacitance and dissipation factor from the CFCP method were obtained for the multiple simulations at 1 and 10 MHz. The predictions were compared with the exact solution of the reference capacitor to estimate the Type A uncertainty contribution in the final results due to the 1-kHz measurements. The Type B uncertainty simulations were run just as the Type A simulations except that the 1-kHz capacitance values were offset by 10 ppm instead of randomly scattered prior to running the CFCP algorithm. The uncertainties produced from this simulation are reported in Section V as 1-kHz Type A and B standard uncertainties.

Note that the Type B uncertainty of the capacitance meter has been approximated conservatively at 10 ppm.

### III. NETWORK ANALYZER MEASUREMENT UNCERTAINTY

The high-frequency single-port measurements used by the CFCP method are provided by a precision network analyzer. Measurements are made from 40 to 200 MHz, depending on the capacitor. The actual measured quantity is the scattering parameter  $S_{11}$ , which is converted into impedance. The network analyzer contributes both Type A and B uncertainties. The Type

A component of uncertainty is the standard deviation of capacitance and dissipation factors based on repeated network analyzer measurements applied to the CFCP algorithm. Note that this value also includes random variations of the capacitor.

The Type B component of uncertainty due to the network analyzer was estimated using software simulations. Again, the solution of the Yonekura circuit model [8] was used to compute the true 4TP capacitance and dissipation factor of the reference capacitor at frequencies of 1 and 10 MHz. Ideal  $S_{11}$  parameters (that would be generated by an errorless network analyzer) were also computed from the circuit equations and applied to the CFCP algorithm to predict 1- and 10-MHz capacitance and dissipation factor behavior. The calculated  $S_{11}$  values were then modified to simulate a network analyzer with offset, gain, and frequency response errors within the manufacturer’s specifications [11].  $S_{11}$  measurements of a NIST-calibrated precision 20-cm air line indicated that the network analyzer was within these specifications.

The Type A and B standard uncertainties in the 4TP characterization due to the network analyzer are reported in Section V.

### IV. REGRESSION ALGORITHM UNCERTAINTY DUE TO VARIATIONS IN CAPACITATOR MANUFACTURING

Still more simulations were performed to determine the uncertainty components of the 4TP capacitance and dissipation factor introduced by the CFCP method. The regression algorithm extrapolates the network analyzer impedance measurements (made over a range of frequencies chosen somewhere between 40–200 MHz) down to 10 MHz and below using the 1-kHz capacitance measurement values, described briefly above, as references. The regression parameters were selected to optimally predict the capacitance frequency characteristic for nominal capacitor values. This test was set up to determine the sensitivity of the method to variability in manufacturing of the capacitor standards.

The circuit solution of the Yonekura model provides reference values of capacitance and dissipation factor at the frequencies of interest. It is also used to obtain high-frequency single-port values. Simulated network analyzer measurement data were used to iteratively extrapolate to the frequencies of 1 and 10 MHz with normally distributed random errors injected into the Yonekura model components according to each component’s uncertainty [8]. For each reference capacitor, the exact solution and the value predicted by the CFCP method was compared. The Type B standard uncertainties attributed to the method are reported in Section V.

### V. UNCERTAINTY RESULTS

Table II labels the standard uncertainty components, and Table III shows the values of the components as well as the expanded standard uncertainties for capacitance and dissipation factor characterization of the standard 4TP capacitors (1, 10, 100, and 1000 pF) at frequencies of 1 and 10 MHz. The uncertainty components are root-sum-squared and then multiplied by two to produce the expanded standard uncertainty values. All capacitance uncertainty components are given in parts in  $10^6$ , labeled as ppm, and all dissipation factor uncertainty

TABLE II  
UNCERTAINTY COMPONENT DESCRIPTIONS

a1	Type A 1 kHz capacitance standard uncertainty
a2	Type A network analyzer standard uncertainty
b1	Type B 1 kHz capacitance standard uncertainty
b2	Type B network analyzer standard uncertainty
b3	Type B CFCP standard uncertainty

TABLE III  
RELATIVE UNCERTAINTY COMPONENTS AND EXPANDED UNCERTAINTIES  
( $k = 2$ )

	a1	a2	b1	b2	b3	U (k=2)
1 pF Capacitance (ppm)						
1 MHz	5	0	10	250	250	700
10 MHz	5	8	10	5000	5000	14000
1 pF Dissipations Factor ( $\mu$ rad)						
1 MHz	5	5	10	100	100	300
10 MHz	5	153	10	2000	2000	5700
10 pF Capacitance (ppm)						
1 MHz	4	1	10	5	1	24
10 MHz	4	76	31	520	75	1100
10 pF Dissipation Factor ( $\mu$ rad)						
1 MHz	4	0	10	9	2	28
10 MHz	4	2	10	295	70	610
100 pF Capacitance (ppm)						
1 MHz	7	0	10	5	0	26
10 MHz	7	9	10	545	7	1100
100 pF Dissipation Factor ( $\mu$ rad)						
1 MHz	7	0	10	1	0	24
10 MHz	7	0	10	51	2	105
1000 pF Capacitance (ppm)						
1 MHz	5	0	10	5	2	25
10 MHz	5	8	36	474	255	1100
1000 pF Dissipation Factor ( $\mu$ rad)						
1 MHz	5	0	22	6	8	50
10 MHz	5	0	610	203	266	1400

components are given in microradians, labeled as  $\mu$ rad. These values will be refined and reevaluated as the authors gain experience with the measurement system.

## VI. FUTURE WORK

The uncertainty analysis reported in this paper consists of simulations that determine the statistical variation of the components of the 4TP capacitor characterization technique. Some assumptions are made regarding the errors and the circuit model derived from measurements of a set of standard capacitors. A theoretical analysis of the network analyzer should be performed in order to compare with the simulations performed and reported upon here.

## ACKNOWLEDGMENT

The authors would like to thank K. Yokoi, leader of the group at Hewlett-Packard Japan that developed this measurement system for his considerable assistance during this project. They also thank T. Aoki, also of Hewlett-Packard Japan, who traveled to NIST to provide his engineering expertise, saving them considerable time in procedural development.

## REFERENCES

- [1] A. D. Koffman, B. C. Waltrip, N. M. Oldham, and S. Avramov-Zamurovic, "Capacitance and dissipation factor measurements from 1 kHz to 10 MHz," in *Proc. Nat. Conf. Standards Laboratories (NCSL) Workshop and Symp.*, Albuquerque, NM, July 19–23, 1998, pp. 63–68.
- [2] R. D. Cutkosky, "Four-terminal-pair networks as precision admittance and impedance standards," *IEEE Trans. Commun. Electron.*, vol. CE-70, pp. 19–22, 1964.
- [3] —, "Techniques for comparing four-terminal-pair admittance standards," *J. Res. Nat. Bur. Stand.*, vol. 74C, pp. 63–77, 1970.
- [4] R. N. Jones, "A technique for extrapolating the 1 kc values of secondary capacitance standards to higher frequencies," NBS, Tech. Note 201, Nov. 1962.
- [5] —, "Evaluation of three-terminal and four-terminal pair capacitors at high frequencies," NBS, Tech. Note 1024, Sept. 1980.
- [6] K. Suzuki, T. Aoki, and K. Yokoi, *New Calibration Method for Four-Terminal Pair Capacitance Standards*. Yokohama, Japan: Hewlett-Packard, 1991.
- [7] T. Aoki, "Calibration method for four-terminal-pair capacitance standards: Progress report," in *Conf. Precision Electromagnetic Measurements (CPEM) Conf. Dig.*, Washington, DC, July 6–10, 1998, pp. 36–37.
- [8] T. Yonekura and T. Wakasugi, "Frequency characteristics of four terminal pair air-dielectric capacitors," in *Proc. Nat. Conf. Standards Laboratories (NCSL) Workshop and Symp.*, Washington, DC, Aug. 19–23, 1990, pp. 469–483.
- [9] B. C. Waltrip and N. M. Oldham, "Digital impedance bridge," *IEEE Trans. Instrum. Meas.*, vol. 44, pp. 436–439, Apr. 1995.
- [10] Y. M. Chang and S. B. Tillett, "NIST calibration service for capacitance standards at low frequencies," NIST, SP 250-47, Apr. 1998.
- [11] *Network Analyzer User's Guide*, Hewlett-Packard, Sept. 1997, p. 7-4.
- [12] B. N. Taylor and C. E. Kuyatt, "Guidelines for evaluating and expressing the uncertainty of NIST measurement results," NIST, Tech. Note 1297, 1994.

**Andrew D. Koffman** (S'86–M'90) received the B.S. degree from the University of Maryland, College Park, in 1988 and the M.S. degree from Vanderbilt University, Nashville, TN, in 1990, both in electrical engineering.

He joined the Electricity Division at the National Institute of Standards and Technology, Gaithersburg, MD, in 1990. He has worked to develop and apply model-based strategies for testing complex electronic systems. He currently works in the area of developing ac impedance measurement systems and impedance calibration services.

**Svetlana Avramov-Zamurovic** received the B.S. and M.S. degrees from the University of Novi Sad, Yugoslavia, in 1986 and 1990, respectively, and the Ph.D. degree from the University of Maryland, College Park, in 1994, all in electrical engineering.

From 1990 to 1994, she was involved in developing a voltage ratio bridge for the NASA Zeno experiment. She was a Guest Researcher at the National Institute of Standards and Technology (NIST), Gaithersburg, MD, from 1990 to 1994. At present, she is an Assistant Professor at the U.S. Naval Academy, Annapolis, MD. Her recent work as a Guest Researcher at NIST involves the development of impedance bridges and measuring techniques.

**Bryan Christopher Waltrip** (M'87) received the B.S. degree in electrical engineering and computer science from the University of Colorado, Boulder, and the M.S. degree in electrical engineering from the Johns Hopkins University, Baltimore, MD.

Since 1984, he has been an Electronics Engineer with the Electricity Division, National Institute of Standards and Technology, Gaithersburg, MD, where he is currently working on precision waveform synthesis and measurement standards in the dc to 1-GHz frequency range.

**Nile M. Oldham** (M'73–SM'92–F'98) received the B.S. degree from Virginia Polytechnic Institute and State University, Blacksburg, in 1966.

Since then, he has been a Physicist and an Electronics Engineer in the Electricity Division, National Institute of Standards and Technology (NIST), Gaithersburg, MD. He is recently retired and working part-time. His recent work at NIST includes the development of electrical standards of voltage, current, phase angle, power, and energy using digital synthesis techniques and the investigation of Internet-based metrology techniques.