

## A RAND NOTE

IMPROVING U.S. CAPABILITY TO DEPLOY  
GROUND FORCES TO SOUTHWEST ASIA IN  
THE 1990s--A BRIEFING

P. M. Dadant

February 1983

N-1943-AF

Prepared for

The United States Air Force

35th  
Year



# Report Documentation Page

*Form Approved  
OMB No. 0704-0188*

Public reporting burden for the collection of information is estimated to average 1 hour per response, including the time for reviewing instructions, searching existing data sources, gathering and maintaining the data needed, and completing and reviewing the collection of information. Send comments regarding this burden estimate or any other aspect of this collection of information, including suggestions for reducing this burden, to Washington Headquarters Services, Directorate for Information Operations and Reports, 1215 Jefferson Davis Highway, Suite 1204, Arlington VA 22202-4302. Respondents should be aware that notwithstanding any other provision of law, no person shall be subject to a penalty for failing to comply with a collection of information if it does not display a currently valid OMB control number.

1. REPORT DATE <b>FEB 1983</b>	2. REPORT TYPE	3. DATES COVERED <b>00-00-1983 to 00-00-1983</b>			
4. TITLE AND SUBTITLE <b>Improving U.S. Capability to Deploy Ground Forces to Southwest Asia in the 1990s--A Briefing</b>		5a. CONTRACT NUMBER			
		5b. GRANT NUMBER			
		5c. PROGRAM ELEMENT NUMBER			
6. AUTHOR(S)		5d. PROJECT NUMBER			
		5e. TASK NUMBER			
		5f. WORK UNIT NUMBER			
7. PERFORMING ORGANIZATION NAME(S) AND ADDRESS(ES) <b>Rand Corporation, 1776 Main Street, PO Box 2138, Santa Monica, CA, 90407-2138</b>		8. PERFORMING ORGANIZATION REPORT NUMBER			
9. SPONSORING/MONITORING AGENCY NAME(S) AND ADDRESS(ES)		10. SPONSOR/MONITOR'S ACRONYM(S)			
		11. SPONSOR/MONITOR'S REPORT NUMBER(S)			
12. DISTRIBUTION/AVAILABILITY STATEMENT <b>Approved for public release; distribution unlimited</b>					
13. SUPPLEMENTARY NOTES					
14. ABSTRACT					
15. SUBJECT TERMS					
16. SECURITY CLASSIFICATION OF:			17. LIMITATION OF ABSTRACT	18. NUMBER OF PAGES	19a. NAME OF RESPONSIBLE PERSON
a. REPORT <b>unclassified</b>	b. ABSTRACT <b>unclassified</b>	c. THIS PAGE <b>unclassified</b>	<b>Same as Report (SAR)</b>	<b>38</b>	

The research reported here was sponsored by the Directorate of Operational Requirements, Deputy Chief of Staff/Research, Development, and Acquisition, Hq USAF, under Contract F49620-82-C-0018. The United States Government is authorized to reproduce and distribute reprints for governmental purposes notwithstanding any copyright notation hereon.

The Rand Publications Series: The Report is the principal publication documenting and transmitting Rand's major research findings and final research results. The Rand Note reports other outputs of sponsored research for general distribution. Publications of The Rand Corporation do not necessarily reflect the opinions or policies of the sponsors of Rand research.

## A RAND NOTE

IMPROVING U.S. CAPABILITY TO DEPLOY  
GROUND FORCES TO SOUTHWEST ASIA IN  
THE 1990s--A BRIEFING

P. M. Dadant

February 1983

N-1943-AF

Prepared for

The United States Air Force

35th  
Year



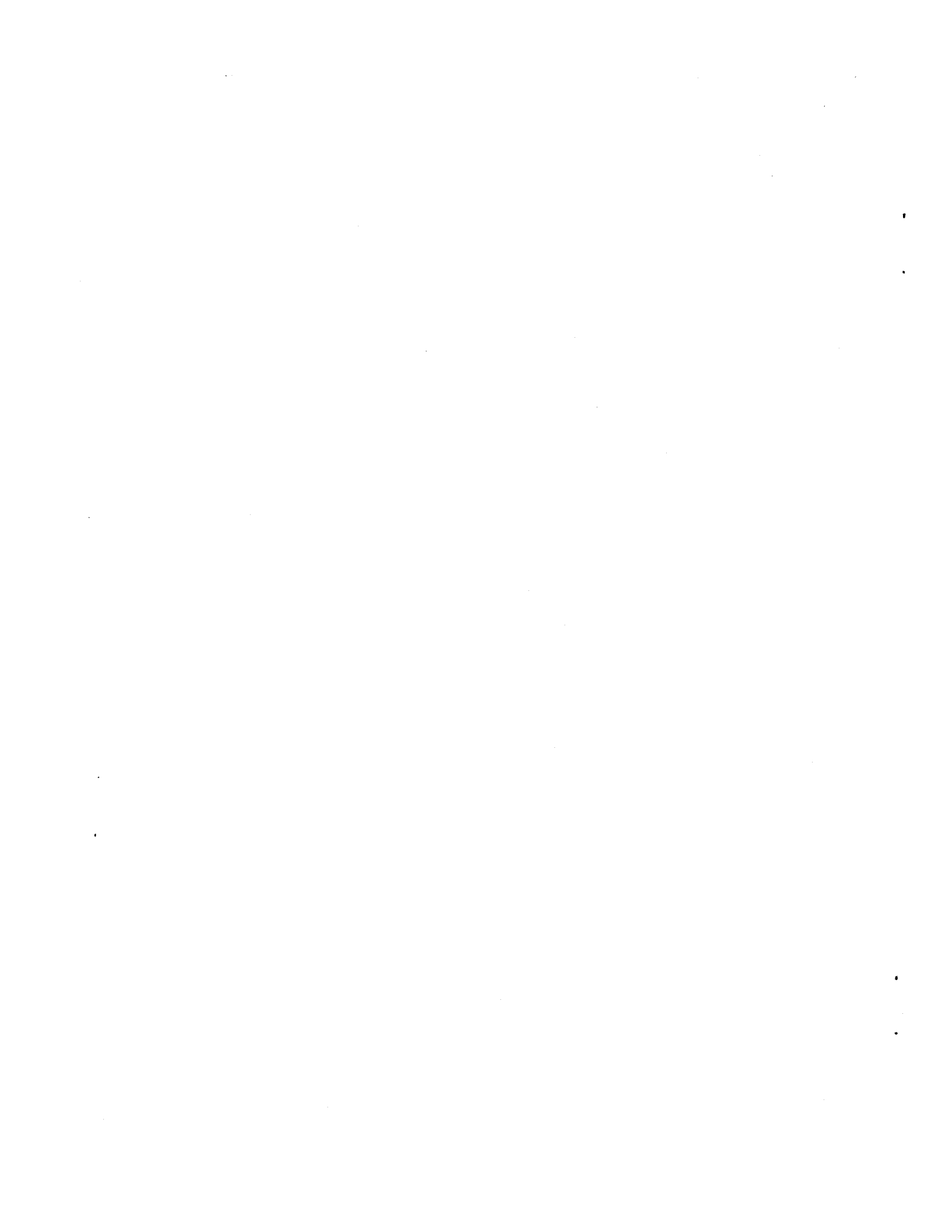

PREFACE

This Note was adapted from a Rand briefing reporting on the results of a study of various systems for improving future U.S. capabilities to project ground forces into Third Areas. The study was part of a larger effort, undertaken for the U.S. Air Force, which examined ways to enhance U.S. leverage in Persian Gulf/Middle East conflicts. Because of the importance of Southwest Asia to U.S. security interests and because of the difficulty of projecting U.S. forces there, that area was used as an example destination. The study was general in form, however, and was not tied to any specific scenario.

The briefing was prepared for and presented to the Air Force Advisory Group for Project AIR FORCE at its November 1982 meeting. The complete study will be reported in Rand Report R-2963-AF, "A Comparison of Methods for Improving U.S. Capability To Project Ground Forces to Southwest Asia in the 1990s," forthcoming.



SUMMARY

Despite recent improvements in the U.S. capability for projecting military power over long distances, rapid force deployment is still possible only on a fairly small scale. This study examined several conventional and unconventional systems that would speed the deployment of divisions with their combat support (DIV + CS) in the 1990s, using Southwest Asia (SWA) as an example destination.

The deployment we considered involves ground forces stationed at Continental U.S. or overseas bases, or with equipment at prepositioning sites. These forces are moved by airlift or sealift to airports or seaports of debarkation (APODs or SPODs) and then to a forward operating base (FOB) for final assembly.

*We estimated the quantities of various additional deployment systems that the United States could acquire and operate for 20 years for \$28.5 billion, added these systems to our baseline system, and compared the performances.* Our evaluation criteria were: the time required to deploy up to 5 DIV + CS; the systems' technical, operational, and political feasibility, including port capacity considerations; their flexibilities in changing destinations and adapting to route closures; the confidence we have in estimating system costs; and the vulnerabilities of ports the systems must use. (Other vulnerabilities were not examined.) Our baseline force consisted of 70 C-5As, 234 C-141Bs, 37 B-747 equivalents from the Civil Reserve Air Fleet, 8 converted SL-7 ships, 331 conventional ships, and the equipment for one Marine division prepositioned on ships at Diego Garcia.

ADDITIONAL AIRLIFT OR SEALIFT

*Conventional airlift offers the advantages of speed and route flexibility, but its immediate response capacity is limited.* A system including 100 added C-5Bs could cut deployment time for one DIV + CS from 22 to 17 days. Because C-5s can use many austere fields, equipment might be delivered directly to the FOB in some cases, making deployment still quicker. An alternative addition of 123 C-17s would perform similarly and be more likely to find usable FOBs.

*A system with 60 added sealift ships such as PD-214s would not improve early deliveries, but would deliver anything over about 3 DIV + CS faster than the system with added airlift. Moreover, ships given warning can move forces close to the destination without committing them to foreign soil. On the negative side, inadequate SPODs and possible denial of narrow passages like the Suez Canal or the Strait of Hormuz could be critical drawbacks.*

Adding 73 large airships--7 1/2 times the volume of any previously built--would make delivery somewhat quicker than adding conventional airlift. These airships might require little terminal port preparation and deliver near the FOB, but have serious operational problems about handling in shifting winds, particularly during loading and unloading, and uncertainties in design and cost estimates.

With 26 surface effect ships added, delivery of 1 to 2.5 DIV + CS would be faster than with added conventional systems. Like conventional sealift, these ships could move troops without committing them to foreign soil, but would risk inadequate SPODs and possible denial of narrow passages. They would require multiple refueling en route to SWA.

#### PREPOSITIONING ASHORE OR AFLOAT

*Prepositioning of equipment on land provides rapid response capability but entails risk. Although 10 sites might be built for our base sum, required inducements to host nations could sharply reduce that number. Airport capacities at prepositioning sites and APODs could limit capability. Even more critical are political questions of what host nations will allow, both for prepositioning and for access during crises, and what the United States is willing to risk.*

A little more than 1 DIV + CS could be placed on 36 new prepositioning ships. This addition would allow quick delivery of the first division, but would suffer most drawbacks of other sealift systems.

*A Mobile Operational Large Island (MOLI, after the unsinkable Molly Brown) floating airbase is a promising prepositioning platform. The concept has been used for offshore oil wells. For efficient operations, one MOLI could have two parallel 10,000-foot runways separated by a parking/loading area for 55 large airlift aircraft. A flotation*

structure of 7500 concrete bottles would produce a very stable structure of low vulnerability. Two such MOLIs could be acquired for our base amount, stocked for 5.6 DIV + CS, or four MOLIs half that size could be stocked for 4.8 DIV + CS.

*Prepositioning on MOLIs could outperform any other system we investigated and would avoid the risks of land prepositioning. Although equipped for propulsion, the MOLI can move at only about 5 knots, so might require months to position for a new destination.*

#### MIXED SYSTEMS

Our analysis suggests that although only prepositioning of equipment permits truly quick force deployment, each system has drawbacks. *A mix designed to capitalize on the advantages and compensate for the drawbacks of each system is most likely to result in an adequate capability for the United States.*

Within our cost limit, a mix of additions to the 1986 baseline, including 44 C-5Bs, 20 PD-214s dedicated to sealift, one land prepositioning site in Southwest Asia, and one additional land prepositioning site, might avoid technical risk, have flexibility to meet contingencies in various places, and facilitate early deployment. With this mix, 1 DIV + CS--and possibly 2, depending on the location of the second prepositioning site--could potentially close at the FOB faster than with an addition of sealift or airlift alone. The political risk of prepositioning ashore, however, could endanger the deployment of the first--and possibly second--DIV + CS.

A different mix could include one large MOLI with 2 DIV + CS aboard and 50 C-5Bs. This mix would emphasize fast delivery of 1 to 3 divisions and eliminate the political risks of land prepositioning. Its performance would be at least comparable to that of the other mix and exceed it if only one of the land prepositioning sites were near the destination.

These are only two of many possible system mixes. Our analysis indicates that *prepositioning of some kind is essential to very rapid deployment, but systems mixes can be selected and meaningfully compared only after decisionmakers decide on priorities among criteria for evaluating the performances of complete systems.*



CONTENTS

PREFACE .....	iii
SUMMARY .....	v
Section	
I. INTRODUCTION .....	1
Schematic of Deployment .....	1
Capability To Project Forces to Southwest Asia in 1982 .....	2
Systems Examined .....	4
Evaluation Criteria .....	5
II. COMPARISONS OF ALTERNATIVE SYSTEMS .....	6
Additional Airlift or Sealift .....	6
Lighter-than-Air Ships .....	9
Surface Effect Ships .....	10
Deployments with Prepositioning Ashore or on Ships .....	13
Mobile Operational Large Island (MOLI) Base for Prepositioning .....	17
III. CAPABILITY WITH MIXES OF SYSTEMS .....	21
Mix A .....	21
Mix B .....	23



## I. INTRODUCTION

In the last few years the United States has recognized a potential problem for deploying forces to Southwest Asia (SWA), and has taken steps to address that problem. I'm sure you have seen analyses of this situation, including, of course, the Congressionally Mandated Mobility Study in which the Air Force and the other services participated last year. In our study, we broadened the subject by including several factors and systems not included in the other studies and by divorcing it from any particular scenario. Although we used SWA as an example because of its importance and the difficulty in reaching it, our results are more broadly applicable to Third Area deployments in general. We have not ended up with a recommendation for any particular overall system because of the many value judgments that must be made in arriving at such a decision, but we have developed a wealth of material useful to decisionmakers. I will hit only a few highlights of our study today; much more information is included in our forthcoming report.

I will briefly diagram the form of deployment we considered and discuss U.S. 1982 capabilities. After describing some system additions and criteria for comparing them, I will discuss and compare these additions for the various criteria, and then develop two mixes of system additions and show their performances.

### SCHEMATIC OF DEPLOYMENT

The deployment we consider begins with forces stationed in the Continental United States (CONUS), or perhaps forces or their equipment prepositioned at some overseas location, and moved by airlift or sealift to airports of debarkation (APODs) or seaports of debarkation (SPODs) in the theater, as depicted in Chart 1. From there the forces must be moved to a forward operating base (FOB), either by ground march or by intratheater airlift,<sup>\*</sup> for final assembly and then deployed to

---

\*Ground march was by the deployed unit's vehicles under their own power. Intratheater airlift was normally by 218 C-130s. When C-5s could land at the FOB, or when C-17s were available, some of those

CHART 1

## SCHEMATIC OF DEPLOYMENT

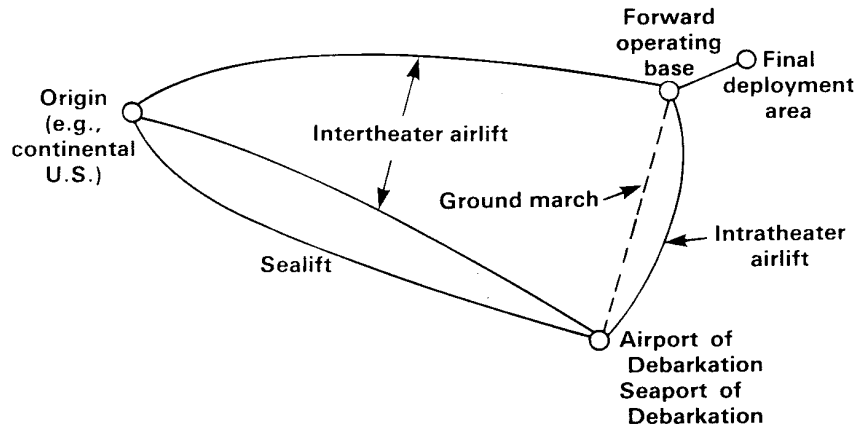

join the battle or take up defensive positions. Alternatively, if the intertheater airlifters can land at the FOB, the forces may be airlifted directly from their origin to that base. Since the final move to the battle area is common to all deployment systems, we have ignored that in our analysis and examined only getting forces to the FOB, which is assumed in this Note to be 300 n mi from the APOD or SPOD. Of course, each of these base areas may be made up of several bases or ports.

### CAPABILITY TO PROJECT FORCES TO SOUTHWEST ASIA IN 1982

The establishment of the Rapid Deployment Force and the prepositioning of Marine and other equipment on the Near Term Prepositioning Ships (NTPS) at Diego Garcia have improved U.S. capability markedly, as indicated on Chart 2. However, in the event of a confrontation too large for these forces to handle, U.S. response in getting sizable forces into this area--and particularly forces with armor protection

---

aircraft were used in intratheater airlift if that would shorten closure time at the FOB. Deployments were adjusted to minimize closure time at the FOB.

CHART 2

**1982 CAPABILITY TO PROJECT GROUND FORCES TO SOUTHWEST ASIA**

<u>Force</u>	<u>Number of men</u>	<u>Closure time at FOB (weeks)</u>	<u>Number of sorties</u>
<u>Prepositioned in Indian Ocean:</u>			
Marine amphibious unit	2,000	0.7	
Marine brigade(s) on NTPS	20,000	2 <sup>a</sup>	
<u>By airlift from CONUS<sup>c</sup>:</u>			
Airborne brigade (no CS)	5,000	1	170
Airborne division + CS	34,000	4	1580
Mech div + CS	37,000	6.5	2400
<u>By sealift from CONUS<sup>d</sup>:</u>			
Mech div + CS	37,000	5 <sup>a,b</sup>	37

<sup>a</sup>Could be reduced significantly with actions based on warning.

<sup>b</sup>6.5 weeks without Suez Canal.

<sup>c</sup>Airlift aircraft used: 70 C-5As and 234 C-141Bs.

<sup>d</sup>Deployment via Suez Canal by 42 ships from a total of 310 eventually available.

and combat support (CS)<sup>\*</sup> for real staying power--would take several weeks, either by air or by sea. How fast a deployment must occur will depend upon the situation, of course. For example, in one scenario used in the Congressionally Mandated Mobility Study, the response called for included the Marine units in the Indian Ocean plus the equivalent, in terms used in our study, of one division with its CS from the CONUS by day 10 and another by day 25. Another scenario called for divisions from CONUS by days 9, 15, and 20. We can say with some certainty that there are far too many possible contingencies for which the response shown in Chart 2 is too slow, and that, especially since the decision to insert force is likely to be made very late in the crisis, the faster the deployment can occur the wider the range of contingencies the United States is prepared to meet.

<sup>\*</sup>Combat support includes units needed to support 30 days of combat but does not include POL or water. No resupply was considered.

SYSTEMS EXAMINED

Our study included many factors and systems that might speed up the deployment of forces. The major work focused on the traditional systems for airlift, sealift, and prepositioning, as well as some unconventional systems that we included in order not to overlook anything that had real promise for improving U.S. capability.

For our analysis we defined a set of equal cost additions to a baseline airlift and sealift force,\* as listed in Chart 3, and compared their capabilities. Each addition to the baseline system has a 20-year life cycle cost of about \$28.5 billion, an amount that can provide a substantial improvement to U.S. force deployment capability. I will discuss each of these systems, examine their performances in deploying a representative ground force to SWA, and compare the other attributes of the systems. The unconventional systems we included are the lighter-than-air ships, the surface effect ships, and a floating airbase we have dubbed the "Mobile Operational Large Island" base, or MOLI, after the unsinkable Molly Brown.

---

\*The baseline force consisted of 70 C-5As, 234 C-141Bs, 37 B-747 equivalents (from the Civil Reserve Air Fleet), 8 converted SL-7 ships, and 331 conventional ships (279 breakbulk, 22 RO/RO, and 30 others). This was the force planned for 1986 as of the spring of 1982 and does not include the additional 50 C-5Bs subsequently planned.

CHART 3

**ADDED FORCE PROJECTION SYSTEMS OF  
EQUAL LIFE CYCLE COST**

(20-year life cycle cost of each = \$28.5 billion)

<u>System</u>	<u>Number acquired</u>
C-5Bs	100 aircraft
Rapid deployment ships	60 ships (PD-214s)
C-17s	123 aircraft
Lighter than air (LTA)	73 airships
Surface effect ships (SES)	26 ships
Prepositioning ashore	10.7 divisions + CS on 10 sites
Prepositioning afloat	1.1 divisions + CS on 36 ships
Prepositioning on MOLIs	5.6 divisions + CS on 2 MOLIs

EVALUATION CRITERIA

One of the more important criteria for comparing these systems, of course, is the time required by each to deploy ground forces to an intended destination. There are many other differences between these systems, however, and many attributes, as listed in Chart 4, that must be considered in any comparison and in any decision about what to acquire. For example, can deployment time be reduced significantly by actions taken on the basis of warning? What is the technical, operational, and political feasibility of each system--that is, can we do it, and how easily? Is the system flexible, not only in changing routes if a preferred route is denied, but in changing destinations to a different part of the world? What confidence do we have in estimating costs so we know how much of a system we can acquire? And last, what is the vulnerability both of the ports the system must use and of the vehicles or methods used by the system? Although this last is an important criterion, it has not been a part of our current study and remains something that should be thoroughly investigated.

CHART 4

**EVALUATION CRITERIA**

<b>Deployment time:</b>	<b>For one division or less For 3 divisions or more Can it be reduced significantly with warning?</b>
<b>Feasibility:</b>	<b>Technical Operational Political Is port capacity adequate?</b>
<b>Flexibility:</b>	<b>In routing if routes are denied In changing destination</b>
<b>Costing:</b>	<b>Confidence in estimates</b>
<b>Vulnerability:</b>	<b>Of ports Of vehicles</b>

II. COMPARISONS OF ALTERNATIVE SYSTEMS

ADDITIONAL AIRLIFT OR SEALIFT

The time required for deployments is one of the most important attributes of a system. Chart 5 shows the number of divisions plus their combat support delivered at the FOB as a function of time after beginning the deployment. From this we see that adding 100 C-5Bs allows us to deliver one division plus combat support in about 17 days, rather than 22 days with the baseline force, and two divisions in about 23 days rather than 30. If 60 new PD-214 sealift ships were added rather than the 100 C-5s, there is no improvement in the early deliveries, but for three divisions or more, the sealift addition completes the delivery more quickly than the airlift addition--assuming that the ships can use the Suez Canal and deliver to a SPOD 300 n mi from the FOB. Note that in every case the early deliveries are all by airlift. The jump at about 21 days is caused by the deliveries from the 33-knot SL-7 ships being converted by the Navy. Airlift deliveries continue until the rest of the sealift force begins its deliveries. From then on both airlift and sealift are delivering forces.

CHART 5

**DEPLOYMENT WITH ADDITIONAL AIRLIFT OR SEALIFT**

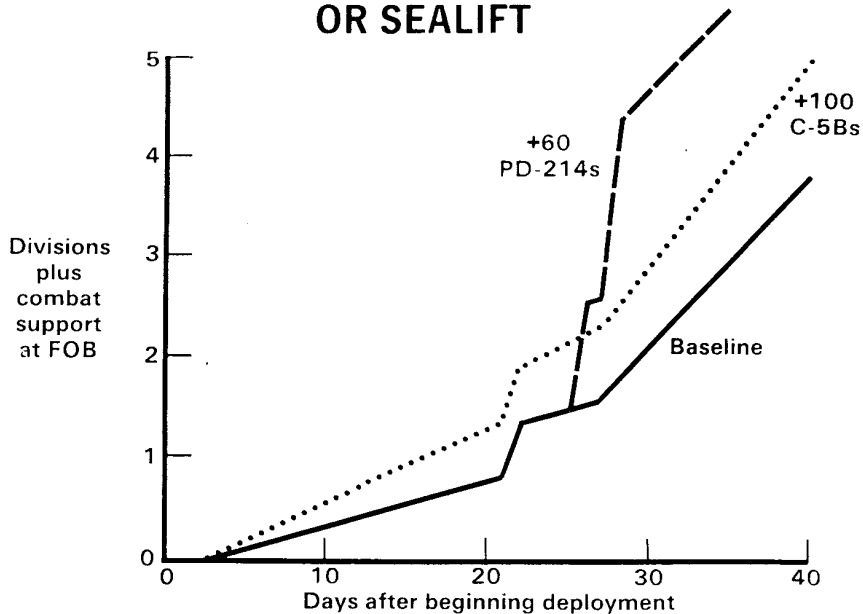

The solid curve in Chart 6 shows the effect of allowing the C-5s to land at the FOB. As you know, the C-5 has considerable short field capability and in many cases will be able to use a FOB for its deliveries. In the case of the additional 100 C-5Bs, about two days can be cut off the delivery time when the FOB is 300 n mi from the APOD. If the distance from the APOD to the FOB were longer than 300 n mi, more time would be saved by these direct deliveries. The C-17 is even more likely to be able to use the FOB than is the C-5. When 123 C-17s are added to the baseline force, and if the FOB is more than about 200 n mi from the APOD (as is the case in Chart 6), deliveries can be made more rapidly than when 100 C-5Bs are added to the baseline force and the C-5s cannot use the FOB, and about as rapidly as when the C-5Bs are added and C-5s can use the FOB. If the FOB is less than about 200 n mi from the APOD, the force with added C-5Bs can deliver to the FOB marginally faster than the force with added C-17s even when the C-5s cannot use the FOB and the C-17s can.

CHART 6

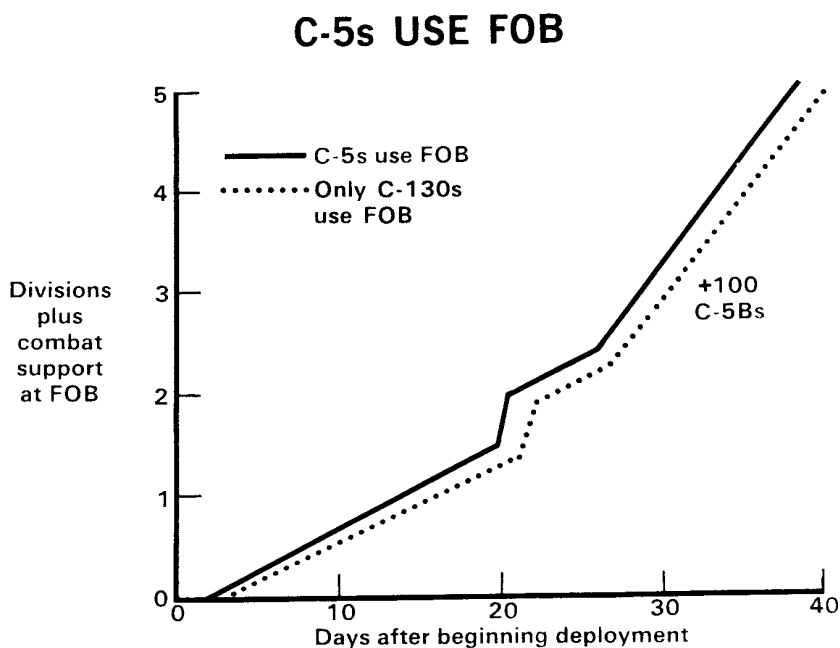

Chart 7 compares airlift and sealift additions to the baseline force for the set of criteria previously discussed. (The chart will be repeated subsequently with other comparisons added.) The first two attributes are compared quantitatively; the quantities given are the days required to complete the deployment to the FOB of the equivalents of one and three representative divisions with their CS. For airlift the times are for the case when the C-5s cannot use the FOB but the C-17s can.

In the comparison of systems for the attributes that are measured qualitatively, we have taken additional airlift as a basis and used stars to designate attributes in which an alternative system appears substantially better, black marks where a system is considerably worse, and question marks where a system appears somewhat worse or there are questions about its capability. Blank spaces do not mean that the systems are equally favorable or unfavorable in this attribute but merely that they do not fit in these three categories.

For example, the addition of 60 new sealift ships offers the opportunity for reducing deployment time if warning permits loading equipment aboard the ships and sailing them forward. If the ships are not so used, however, airlift can deliver a small force, say a regiment or brigade, much more quickly than sealift.

Available airports in Third Areas tend to have more capability to support a large airlift than do available seaports to support a large sealift, and if they do not, airport capability can be more quickly increased by, for example, laying pierced steel planking to increase taxiways and parking areas. Sealift is also constrained by the presence of land masses and must often depend upon narrow straits or canals for the shortest route. If the Suez Canal is not available for a deployment to the Persian Gulf, for example, sealift's best alternative is a route around Africa. Or if the Strait of Hormuz is closed, sealift might have to use Indian Ocean ports that could sharply increase the distance to the FOB and present serious problems for ground march because of a lack of roads. If airlift's shortest route is denied, other routes are usually available that are only slightly longer.

CHART 7

### COMPARISON OF ADDED FORCE PROJECTION SYSTEMS

Criterion	Attribute	System Added						
		100 C-5Bs / 123 C-17s	60 PD-214s	73 LTAs	26 SESs	Prepositioning		
						10 Land Sites (11 div.)	36 Ships (1.1 div.)	2 MOLLs (5.6 div.)
Deployment time	1 div.	17/16	22					
	3 div.	31/30	27					
	reducibility		★					
Feasibility	technical							
	operational							
	port capacity		■					
	political							
Flexibility	routing		■					
	destination							
Cost	confidence							
Survivability	of ports		?					
	of vehicles	NOT EVALUATED						

#### LIGHTER-THAN-AIR SHIPS

One of the unconventional systems we examined for lifting the divisions was the lighter-than-air ship (LTA). The design we examined, shown in Chart 8, was based on a comprehensive study done by Douglas Aircraft Company. This would be a very large airship, about 7 1/2 times the volume of anything previously built, but the Goodyear people could see nothing to bar the feasibility of its construction. With refueling en route its payload could be more than five times that of the C-5. However, it flies at one-fifth the C-5 speed. One desirable attribute is that it could set its payload down in any clearing along a road--near the FOB, for example. A mobility force with these airships added was nearly identical in performance to that with added C-5s when the C-5s could use the FOB.

CHART 8

## LIGHTER-THAN-AIR SHIPS (LTAs)

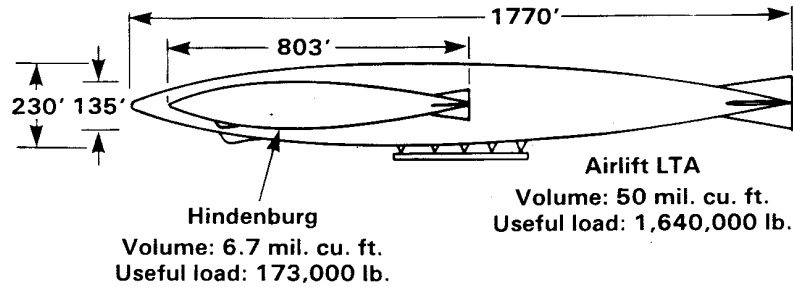

**Advantages:**

Payload to 6300 n mi - 410 tonnes (900,000 lb.)  
with one refueling - 560 tonnes (1,235,000 lb.)

**Disadvantage:**

Speed - 90 knots

In our comparison in Chart 9 we raise questions about the technical feasibility only because the LTA is so much larger than any airship previously built. But there are serious operational questions about handling in shifting winds, particularly during loading and unloading. We also have less confidence in our cost estimates for this system, which means that the number of 73 LTAs is not as firm an estimate as those for some of the other systems. However, the lack of a requirement for terminal ports is certainly an advantage, from the viewpoints of both port capacity and survivability.

### SURFACE EFFECT SHIPS

The Navy has been developing surface effect ships (SESSs) for about the last 20 years. A 200-ton experimental vessel of this type is in use and one weighing over 1000 tons is under consideration. The design we used, shown in Chart 10, comes from a proposal for a logistics ship 10 times that large. This type of ship has two particular advantages.

CHART 9

### COMPARISON OF ADDED FORCE PROJECTION SYSTEMS

Criterion	Attribute	System Added						
		100 C-5Bs/ 123 C-17s	60 PD-214s	73 LTAs	26 SESs	Prepositioning		
						10 Land Sites (11 div.)	36 Ships (1.1 div.)	2 MOLIs (5.6 div.)
Deployment time	1 div.	17/16	22	15				
	3 div.	31/30	27	30				
Feasibility	reducibility		★					
	technical							
	operational							
	port capacity			★				
Flexibility	routing							
	destination							
Cost	confidence							
Survivability	of ports		?	★				
	of vehicles	NOT EVALUATED						

CHART 10

### SURFACE EFFECT SHIPS (SESs)

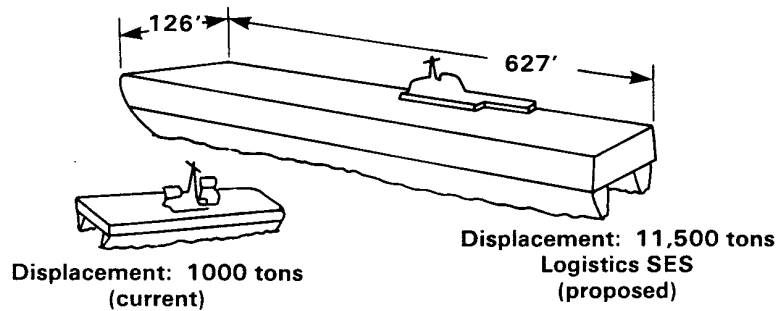

**Advantages:**

- Deck space - 2.2 times conventional ship of same displacement
- Speed - 51 knots vs. 23 knots

**Disadvantage:**

- Range - 3,500 n mi with 3,200-ton payload

One is that the deck area is over twice as large for a given displacement as that of a conventional ship. Second, the vessel can make over 50 knots, compared with 20 to 25 knots for a conventional ship. The SES is a big fuel consumer, however, which means that the ships would have to be refueled twice on the 8600-n mi route through the Suez Canal and at least three times in going around Africa. These ships could be refueled at sea, although the Navy would undoubtedly be hard pressed to furnish multiple refueling for a fleet of 26 ships. Refueling in ports would require port-to-port routes which would lengthen the trip.

The speed of these ships means that equipment they deliver on a route through the Suez Canal could be at the FOB in about 17 days, as shown in Chart 11. Then they could make a round trip with deliveries to the FOB again on about day 35. Compared to conventional sealift and airlift additions, this addition reduces deployment time in the 1 to 2 1/2 division range.

CHART 11

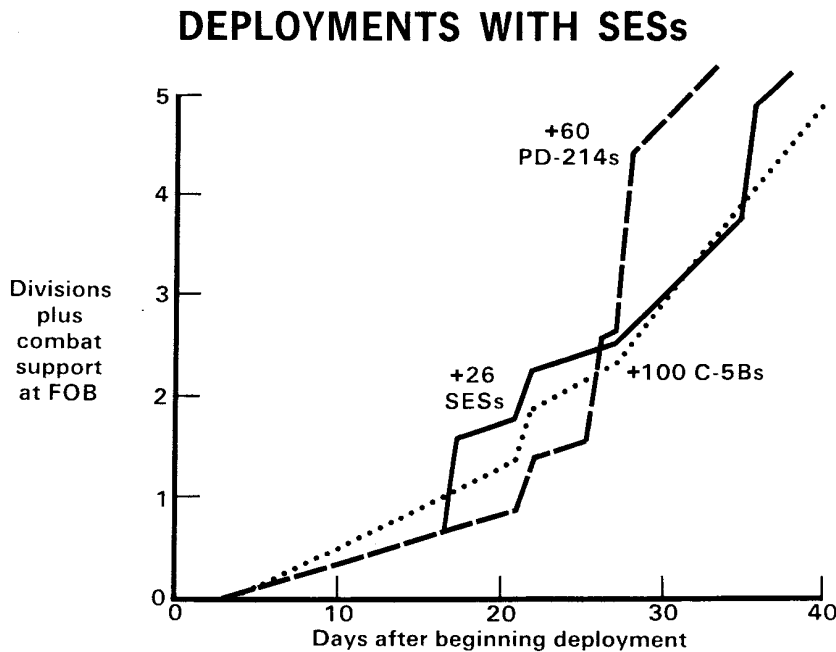

In our comparison in Chart 12, this system shares with conventional sealift the possibility of predeployment of troops to offshore of the objective area. It also shares questions about available port capacity and routing flexibility, however, as well as having some technical question because of the size of these ships compared to anything of this design that has been built. That factor also creates less confidence in our cost estimates. A change in the cost, of course, would change the number that could be acquired.

DEPLOYMENTS WITH PREPOSITIONING ASHORE OR ON SHIPS

Prepositioning of materiel configured to unit sets (POMCUS) ashore is a well established concept. The Army has a large amount of POMCUS in Europe. For \$28.5 billion we could build 10 POMCUS sites and purchase and preposition complete duplicate sets of equipment for nearly 11 divisions plus their combat support, and maintain that system for 20 years. These sites could be located around the world in any place where we might want to deploy divisions in the future. The performance of the

CHART 12

**COMPARISON OF ADDED FORCE PROJECTION SYSTEMS**

Criterion	Attribute	System Added						
		100 C-5Bs/ 123 C-17s	60 PD-214s	73 LTAs	26 SESs	Prepositioning		
						10 Land Sites (11 div.)	36 Ships (1.1 div.)	2 MOLIs (5.6 div.)
Deployment time	1 div.	17/16	22	15	17			
	3 div.	31/30	27	30	31			
	reducibility		★		★			
Feasibility	technical							
	operational							
	port capacity			★				
	political							
Flexibility	routing							
	destination							
Cost	confidence							
Survivability	of ports		?	★	?			
	of vehicles	NOT EVALUATED						

★ Superior  
 ■ Especially troublesome  
 ? Worrisome

system would depend on the number of division sets that are close to the deployment area. The representative distance on Chart 13 of 800 n mi from the APOD is about the distance from Ras Banas in Egypt to Dhahran, Saudi Arabia. If only one division is that close it could be delivered by airlift in about 9 days, much more quickly than by any of the systems previously discussed. Delivery of the second division would also be quicker. With two divisions prepositioned this close, they could both be delivered in about 12 days and the third division from the CONUS would arrive more quickly than with the other systems.

For \$28.5 billion we could purchase 36 new ships, purchase and preposition on those ships duplicate sets of equipment for a little more than one division plus its combat support, and operate that system for 20 years. The performance shown in Chart 14 could be achieved with the ships stationed 2500 n mi from the SPOD. This is about the distance from Diego Garcia to the seaport near Dhahran. About 4 1/2 days could be cut from the delivery time for equipment aboard these ships if the ships were moved to 200 n mi from the SPOD.

CHART 13

### DEPLOYMENTS WITH PREPOSITIONING ASHORE

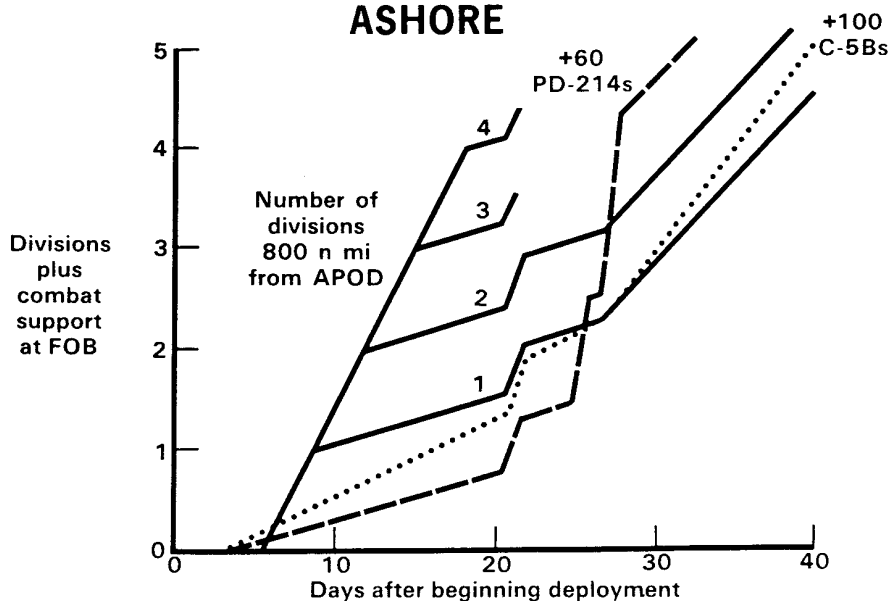
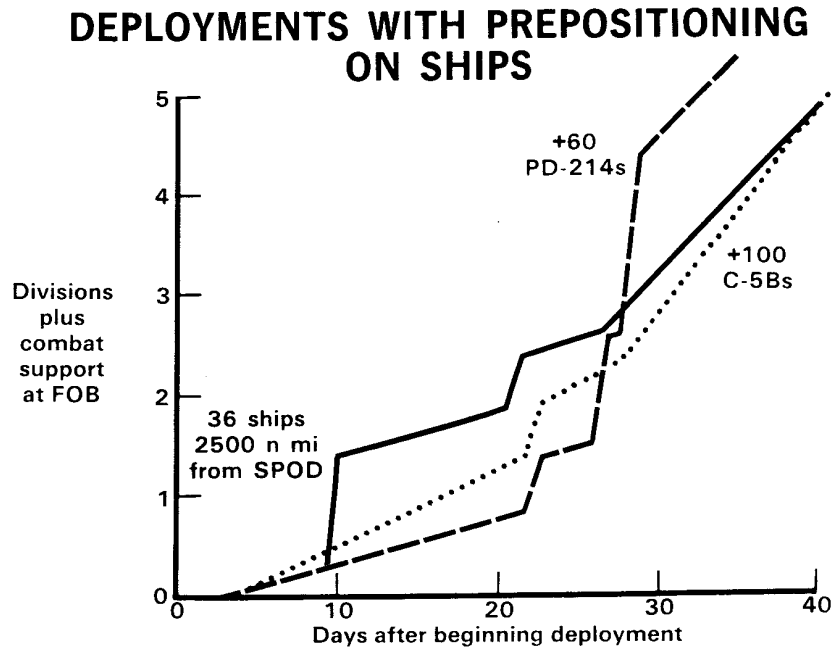

CHART 14



As Chart 15 indicates, either of these prepositioning systems can deliver a division or less more quickly than the systems previously considered. Land-based prepositioning may also be able to deliver 3 divisions comparatively more quickly if that many are close to the destination.

Ship-based prepositioning might have a star for deployment time reducibility, but we have not put one there because of operational questions about preparing the equipment for issue. As you know, this preparation can take several days even with ideal circumstances and many extra people. Getting these people aboard and the equipment prepared if the ships have already left port leaves some questions.

The most troublesome aspect of land-based prepositioning is the political questions that arise. First, how much will host nations allow the United States to preposition on their soil? Second, how much is the United States willing to risk prepositioning in view of the possibility of losing the equipment in something like the Iranian experience? And, third, even if the United States does not lose the

CHART 15

### COMPARISON OF ADDED FORCE PROJECTION SYSTEMS

★ Superior  
 [Black Box] Especially troublesome  
 ? Worrisome

Criterion	Attribute	System Added						
		100 C-5Bs/ 123 C-17s	60 PD-214s	73 LTAs	26 SESs	Prepositioning		
						10 Land Sites (11 div.)	36 Ships (1.1 div.)	2 MOLLs (5.6 div.)
Deployment time	1 div.	17/16	22	15	17	9	10	
	3 div.	31/30	27	30	31	<sup>a</sup>	29	
	reducibility		★		★			
Feasibility	technical							
	operational							?
	port capacity			★		?		
	political							
Flexibility	routing							?
	destination					?		?
Cost	confidence							
Survivability	of ports		?	★	?			?
	of vehicles	<b>NOT EVALUATED</b>						

<sup>a</sup>32, 24, or 15 if 1, 2, or 3 division-plus-CS sets are prepositioned 800 n mi from APOD.

equipment, will it be able to use it during a contingency in which a host government takes a different view than that of the United States.

The political factor also affects the confidence we have in our cost estimates, since we have not included any rental of land for the sites nor any economic aid, military aid, or similar inducements that must be given a host government in order to permit prepositioning. These additional 20-year costs could be very substantial and could sharply reduce the number of sites built for \$28.5 billion.

Prepositioning on ships does not have these drawbacks but does share with other ship systems the questions about adequacy of port capacity in the theater.

MOBILE OPERATIONAL LARGE ISLAND (MOLI) BASE FOR PREPOSITIONING

The third unconventional system we examined is the MOLI, which is a floating airbase. Chart 16 suggests one possible configuration with runways at the extremities to furnish adequate runway separation and a loading area in the center that will accommodate about 55 large airlift aircraft simultaneously. The MOLI has two decks with the airbase on top and the under deck for prepositioned equipment storage and personnel facilities. Equipment would be airlifted to the APOD.\*

Our design was an attempt to maximize efficiency, but the MOLI need not be this large. A runway large enough for airlift aircraft operations and a loading area for several such aircraft are the initial requirements. Since the design is modular, the base could subsequently be enlarged.

---

\* Or perhaps directly to the FOB.

CHART 16

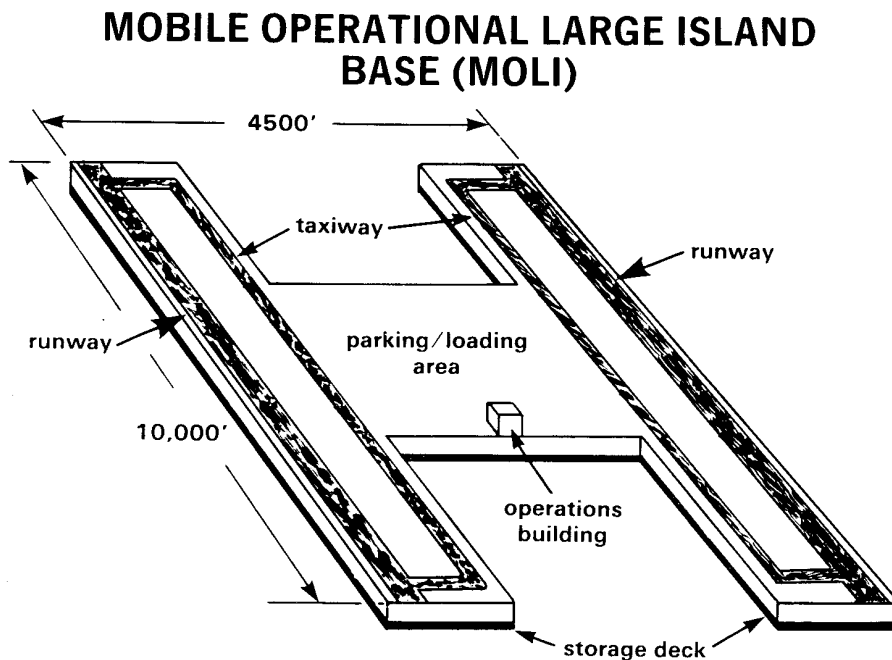

The flotation structure for the MOLI could consist of a large number of reinforced concrete bottles, as shown in Chart 17. These bottles have long, relatively slender necks with the water level about midway on the neck of the bottle. All the wave action takes place on these bottle necks and has minimal effect on the total structure. The bottles are about 200 feet long and 25 to 30 feet in diameter. Our design for the MOLI would have over 7500 of these bottles. The concept of these bottles has been successfully tested and smaller floating platforms have been used as oil drilling rigs and oil production platforms. The MOLI would merely be a large aggregation of these modules.

For \$28.5 billion we could acquire two MOLIs of our design, purchase and house aboard duplicate sets of equipment for about 5 1/2 divisions plus combat support, and operate them for 20 years.\* If both are located about 500 n mi from the APOD, the forces could be at the forward operating base in a relatively short time, as shown in Chart 18--one division in less than 9 days, and three divisions in less than 15 days.

---

\* Alternatively, we could acquire four MOLIs half that size with equipment for about 1.2 divisions plus combat support aboard each, and operate them for 20 years.

CHART 17

### STRUCTURAL SCHEME FOR FLOATING BASE

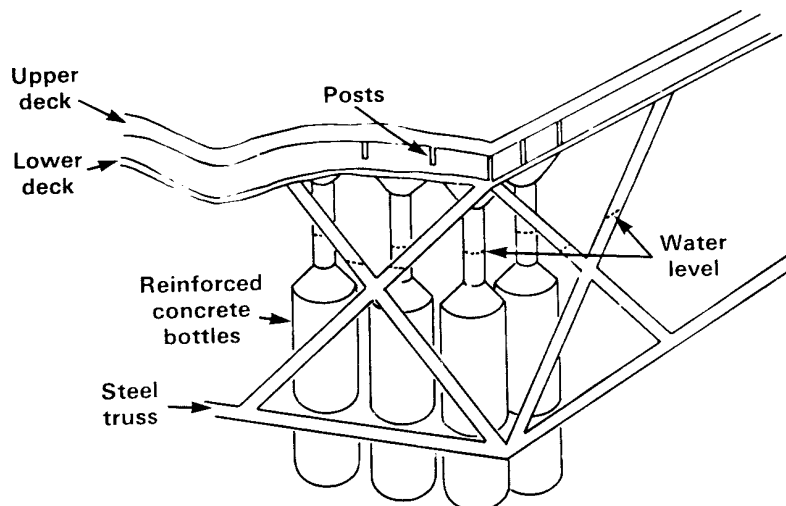
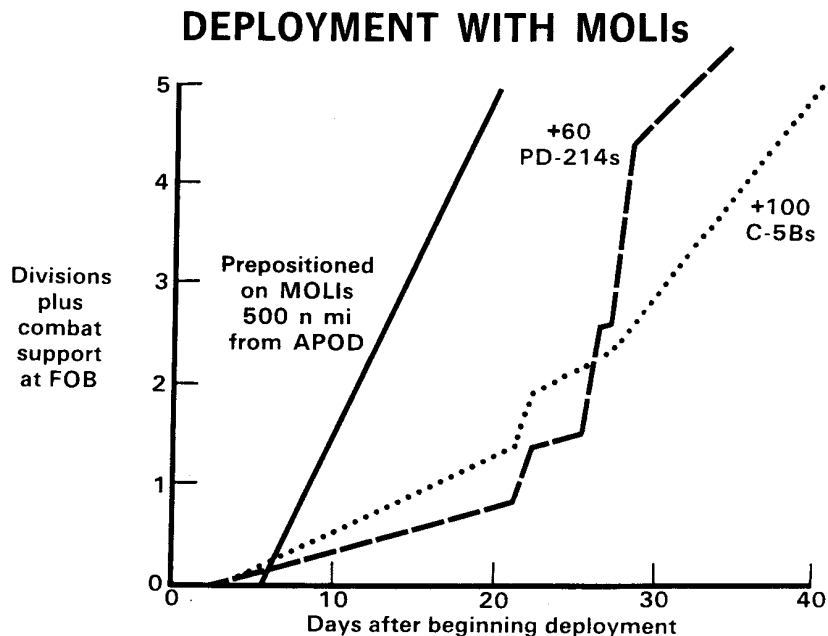

CHART 18



On our comparison Chart 19, the system with MOLIS can deliver one or three divisions\* at least as quickly as the other systems, and usually more quickly.

Our design does include built-in propulsion so the MOLIS can move, but at a very slow speed of about 5 knots. Thus, it could move not only closer to the destination during a crisis, but also to a different part of the world. That would take some time, however. For example, in its initial deployment the MOLIS could move from the East Coast of the United States to the Arabian Sea in about three months.

The MOLIS has an additional flexibility not shown on this chart: The base can be used for many other purposes. For example, it could be a bomber base, a fighter aircraft air defense base, a command and control headquarters and communications site, or a fighter-bomber base. It would belong solely to the United States and could be used for any purpose the United States chooses.

\* Or more, as shown on Chart 18.

CHART 19

## COMPARISON OF ADDED FORCE PROJECTION SYSTEMS

Criterion	Attribute	System Added						
		100 C-5Bs/ 123 C-17s	60 PD-214s	73 LTAs	26 SESs	Prepositioning		
						10 Land Sites (11 div.)	36 Ships (1.1 div.)	2 MOLLs (5.6 div.)
Deployment time	1 div.	17/16	22	15	17	9	10	9
	3 div.	31/30	27	30	31	<sup>a</sup>	29	15
	reducibility		★		★			
Feasibility	technical							?
	operational						?	
	port capacity			★		?		?
	political							
Flexibility	routing						?	
	destination					?	?	
Cost	confidence							?
Survivability	of ports		?	★	?			
	of vehicles	<b>NOT EVALUATED</b>						

<sup>a</sup>32, 24, or 15 if 1, 2, or 3 division-plus-CS sets are prepositioned 800 n mi from APOD.

### III. CAPABILITY WITH MIXES OF SYSTEMS

The comparison on Chart 19 tends to confirm that no one system will have all the strengths we want while avoiding risks and troublesome aspects. Only with prepositioning of equipment (or predeployment of forces, which entails higher costs and even more severe political problems at home and abroad) can a division-size force be deployed to SWA in less than 10 days. The prepositioning systems can deploy forces of a division or less, and sometimes of several divisions, decidedly more quickly than the other systems, but each has its drawbacks. A mix of additional systems seems preferred. The desired mix will depend on judgments of the relative values of various system attributes.

#### MIX A

For example, we might adopt a mix, as shown in Chart 20, that emphasized incurring low technical risk and maintaining flexibility in meeting contingencies in various places, while still helping to meet requirements for early force deployment, but accepting some political risk. The mix of systems that stays within the \$28.5 billion 20-year life cycle cost might then consist of increases in airlift and sealift, with some prepositioning ashore. The political risk of such prepositioning could endanger the quick deployment of the first division.

As Chart 21 shows, if only one of these prepositioned division sets were as close as 800 n mi from the APOD, that division could close at the FOB in about 8 days, a second division from the CONUS by about day 22, and a third from the CONUS by about day 26. That is roughly comparable to the sealift-only addition for three or more divisions and to the addition of only airlift for two divisions, but is substantially better than either for the first division. If the second prepositioned division set were, say, 2500 n mi away, and if both could be used, the second could close at the FOB on about day 15 and a third from the CONUS on about day 23, a substantial improvement over the sealift or airlift additions for each of the first three divisions.

CHART 20

### MIX A

- **Criteria:**
  1. Reduce deployment time for 1 division
  2. Avoid technical risk
  3. Maintain flexibility
  4. Accept moderate political risk
- **Components of mix:**
  - 44 C-5Bs
  - 20 PD-214s, dedicated to sealift
  - 2 prepositioning sites ashore, 1 in SWA

CHART 21

### DEPLOYMENT WITH MIX A

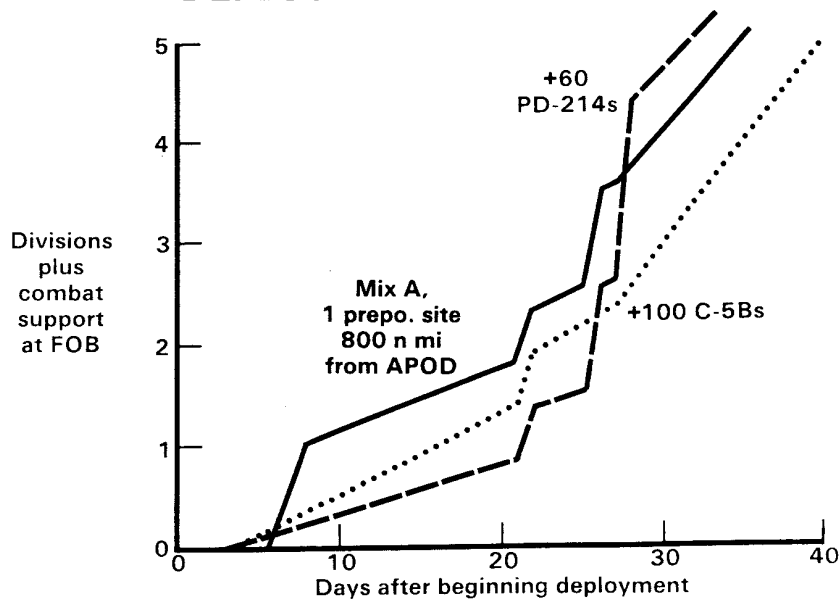

MIX B

Another mix, shown in Chart 22, might put emphasis on quick delivery of one to three divisions while accepting some technical risk but avoiding political risk. This could be satisfied by the acquisition of one MOLI, with equipment for two divisions plus combat support, and 50 additional C-5Bs.

If the MOLI were 500 n mi from the APOD and everything worked as advertised, this force could put the first division with its combat support at the FOB by day 9, the second by day 13, and the third by day 21, as shown on Chart 23. This would also be a substantial improvement over the conventional sealift or airlift additions for each of the first three divisions, and, for the second and third divisions, a big improvement over Mix A if only one of the prepositioning sites ashore were close to the destination.

These are only two examples of mixed systems. Many other mixes are possible and could be evaluated by our methodology.

From our study it does appear that the United States needs to improve its capability to deploy forces to Southwest Asia, and that some mixture of added systems is most desirable. For quick deployment, the mixture should include some prepositioning of equipment, as do the two we have illustrated here. Most importantly, the decisionmakers must decide on the priorities among criteria for evaluating the performance of complete systems. Only then can system mixes be selected and compared in a complete and meaningful way.

CHART 22

### MIX B

- **Criteria:**
  1. Reduce deployment times for 1 and 3 divisions
  2. Avoid political risk
  3. Accept moderate technical risk
- **Components of mix:**
  - 1 MOLI with 2 division-plus-CS sets
  - 50 C-5Bs

CHART 23

