

Defensie



The Dutch perspective on C2 - Sim coupling

Major John Janssens

DMO / C3I / Simulation Expertise Centre

Report Documentation Page

Form Approved
OMB No. 0704-0188

Public reporting burden for the collection of information is estimated to average 1 hour per response, including the time for reviewing instructions, searching existing data sources, gathering and maintaining the data needed, and completing and reviewing the collection of information. Send comments regarding this burden estimate or any other aspect of this collection of information, including suggestions for reducing this burden, to Washington Headquarters Services, Directorate for Information Operations and Reports, 1215 Jefferson Davis Highway, Suite 1204, Arlington VA 22202-4302. Respondents should be aware that notwithstanding any other provision of law, no person shall be subject to a penalty for failing to comply with a collection of information if it does not display a currently valid OMB control number.

1. REPORT DATE FEB 2010		2. REPORT TYPE N/A		3. DATES COVERED -	
4. TITLE AND SUBTITLE The Dutch perspective on C2 - Sim coupling				5a. CONTRACT NUMBER	
				5b. GRANT NUMBER	
				5c. PROGRAM ELEMENT NUMBER	
6. AUTHOR(S)				5d. PROJECT NUMBER	
				5e. TASK NUMBER	
				5f. WORK UNIT NUMBER	
7. PERFORMING ORGANIZATION NAME(S) AND ADDRESS(ES) DMO / C3I / Simulation Expertise Centre				8. PERFORMING ORGANIZATION REPORT NUMBER	
9. SPONSORING/MONITORING AGENCY NAME(S) AND ADDRESS(ES)				10. SPONSOR/MONITOR'S ACRONYM(S)	
				11. SPONSOR/MONITOR'S REPORT NUMBER(S)	
12. DISTRIBUTION/AVAILABILITY STATEMENT Approved for public release, distribution unlimited					
13. SUPPLEMENTARY NOTES See also ADA564685. 2010 Coalition Battle Management Language Workshop (Atelier 2010 sur le langage de gestion du champ de bataille pour les operations en coalition). RTO-MP-MSG-079					
14. ABSTRACT					
15. SUBJECT TERMS					
16. SECURITY CLASSIFICATION OF:			17. LIMITATION OF ABSTRACT	18. NUMBER OF PAGES	19a. NAME OF RESPONSIBLE PERSON
a. REPORT unclassified	b. ABSTRACT unclassified	c. THIS PAGE unclassified			

Contents

- **Introduction**
- **The TACTIS project and C2 – SIM integration**
- **Using a COTS datamapper**
- **Phased approach for TACTIS C2 – SIM integration**
- **Recommendations**

Introduction

C2 – Simulation Integration

Command & Control (C2) systems should be integrated with simulators for:

1. Training systems
2. Mission rehearsal
3. Decision support

Introduction

Objective and reason for study

Objective

- Find a reusable solution for coupling C2-Sim systems for the long term

Reason

- Urgency in project TACTIS.

Principles/conditions

- Use operational C2 equipment and applications
- The C2 systems should not need adjustment for C2 - sim coupling

Introduction

Operational systems



YAS-4442



FENNEK

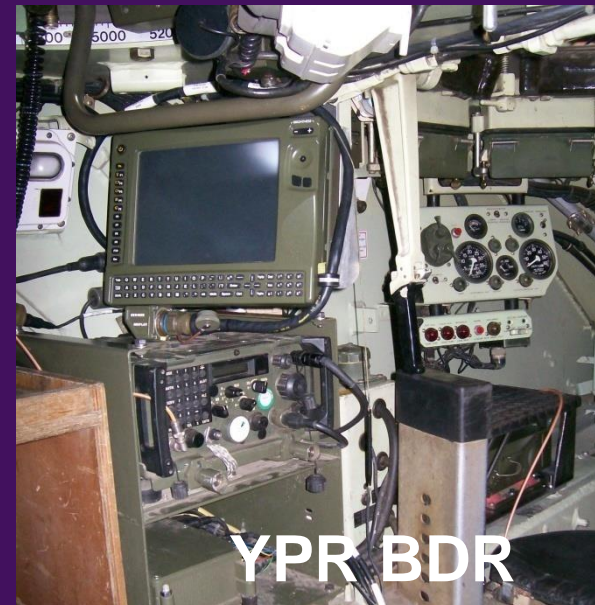

YPR BDR

Operational environment



CV90 IGV

Introduction

What is TACTIS ?

Objective

- Find a reusable solution for coupling C2-Sim systems for the long term

Reason



C2 Simulation integration

1. The TACTIS project required Command & Control (C2) integration with simulation for unit level training using Virtual and Constructive simulators.
2. A reusable solution leads to the requirement that integration of other simulators, like the Command Staff Trainer (Constructive Simulation), must also be supported.

Scope

Command & Control (C2)

Training Simulators

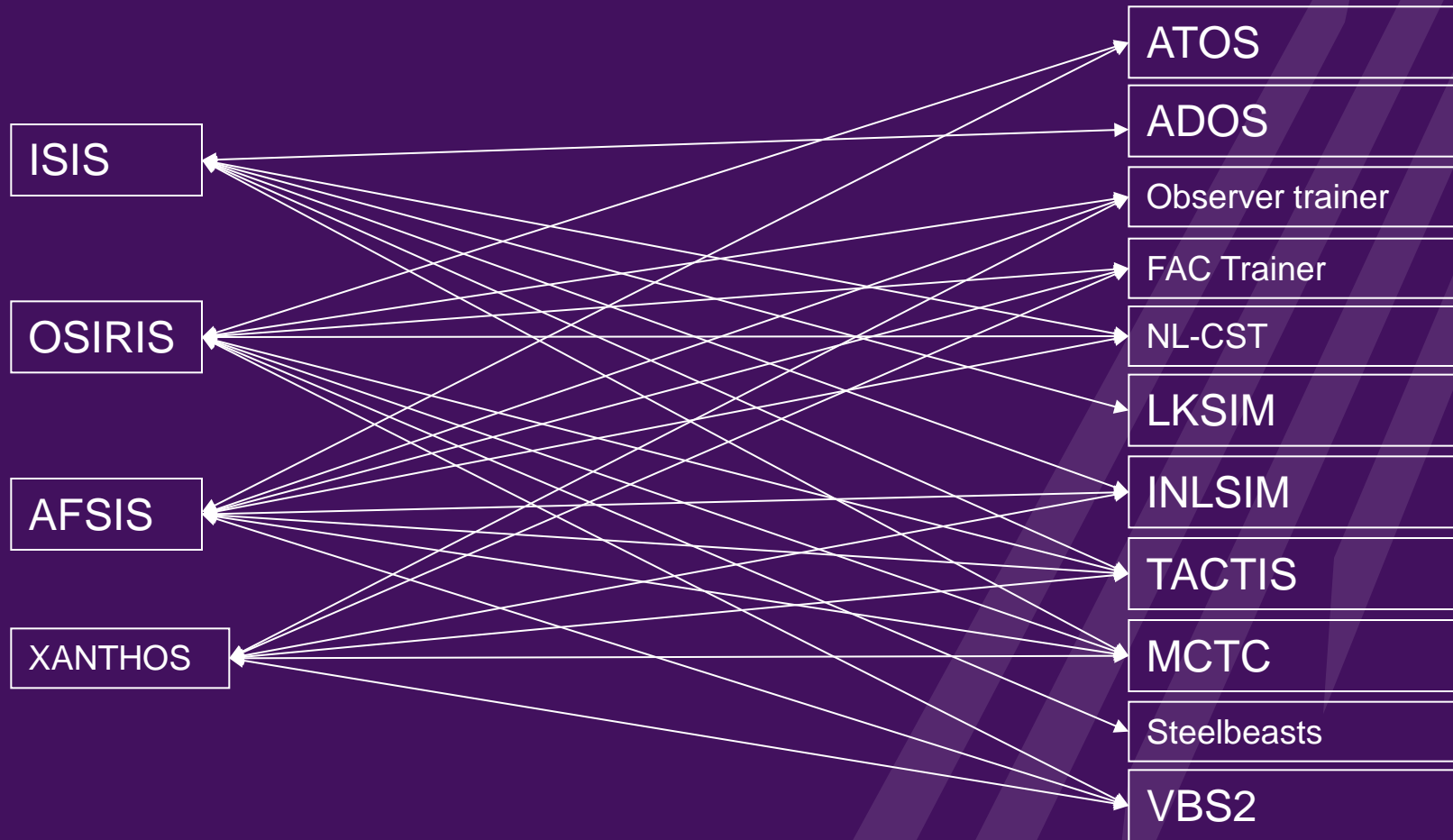

The NL C2 domain (1)



Applications

Presentation support

Data service

Synchronization

C2 Framework

Persistency service

MIP gateway

Distribution service

TITAAN (networking)

CNR networking

The NL C2 domain (2)

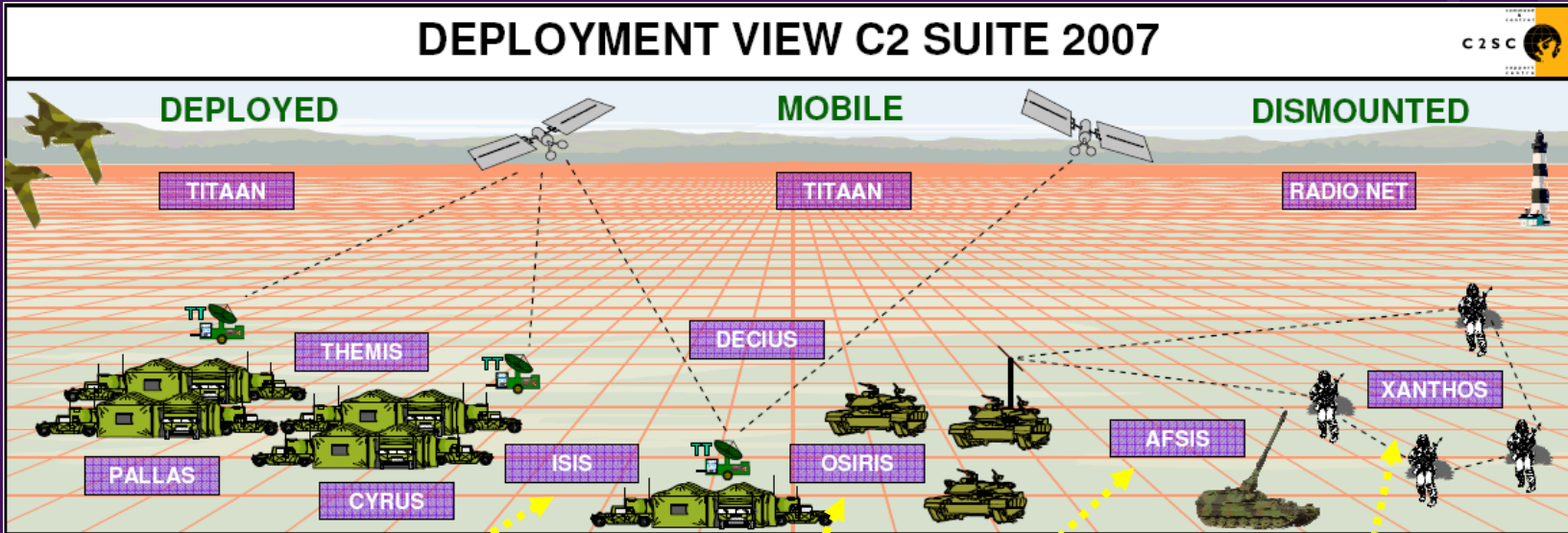

ISIS **OSIRIS** **AFSIS** **XANTHOS**

Applications

Scope

Command & Control (C2)

Training Simulators

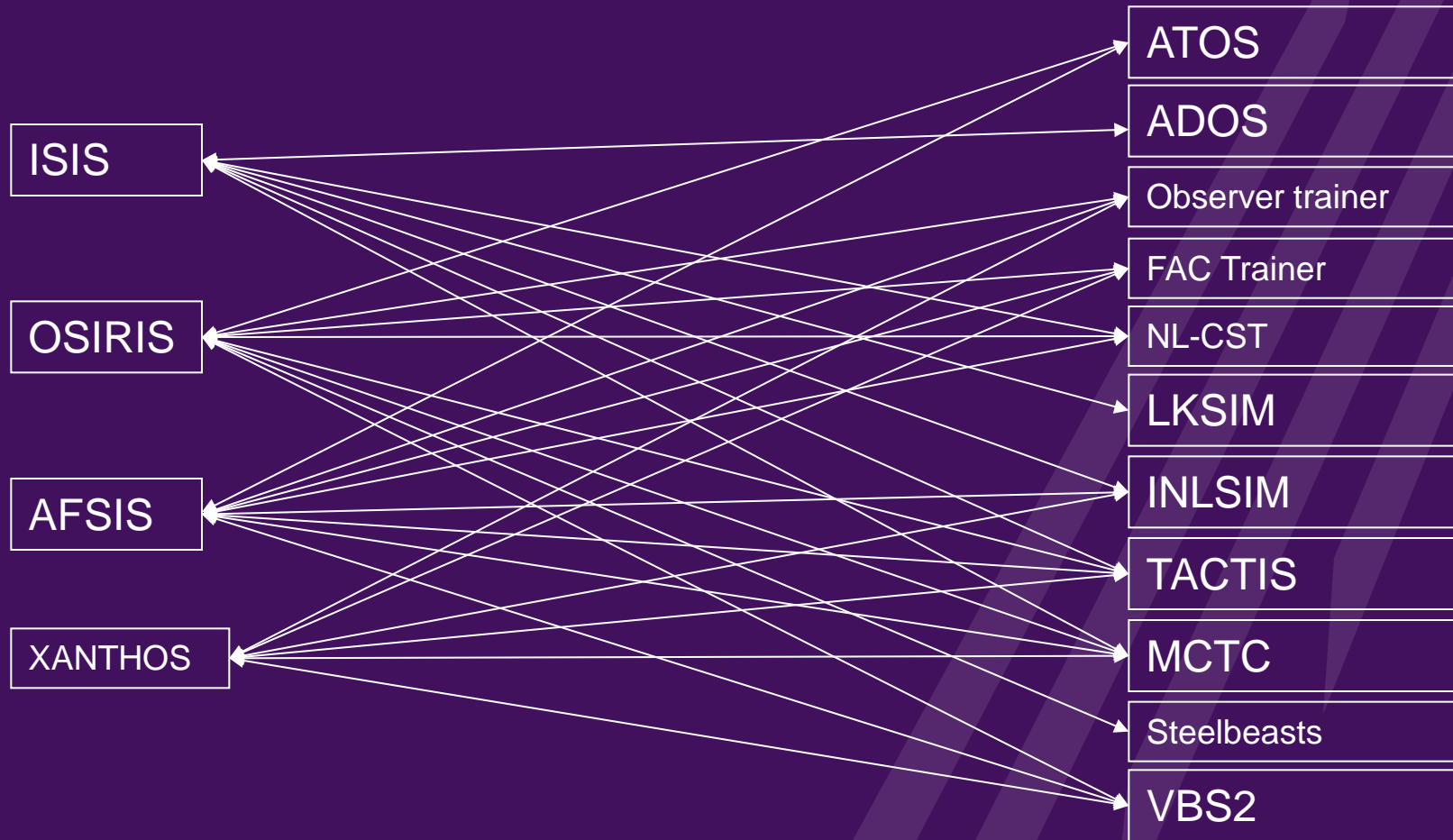

NL simulation training domain

Artillery procedure chain trainer
Air Defense procedure trainer
Observer trainer
Forward Air Controller simulator
Command and Staff trainer
Logistics supply chain simulator
Intelligence simulator
Tactical Indoor simulation
Mobile Combat Training Centre
Game Steelbeasts
Game VBS2

Training Simulators

ATOS

ADOS

Observer trainer

FAC Trainer

NL-CST

LKSIM

INLSIM

TACTIS

MCTC

Steelbeasts

VBS2

Scope

Command & Control (C2)

Training Simulators

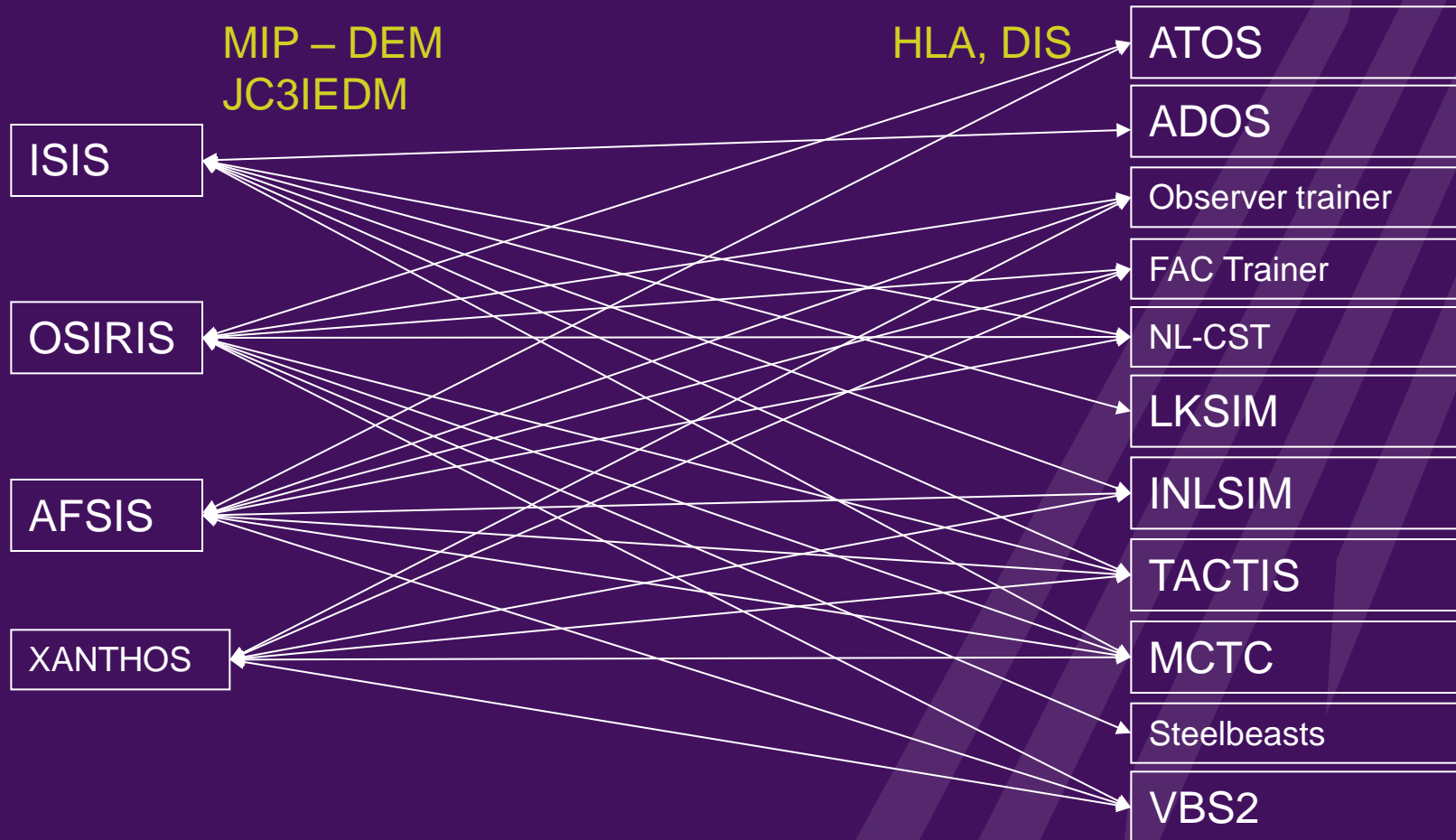

Used input for the C2 - Sim information exchange analysis

- User requirements for training systems
- Standards under development: MSDL, C-BML
- Experience with existing C2 –Sim links

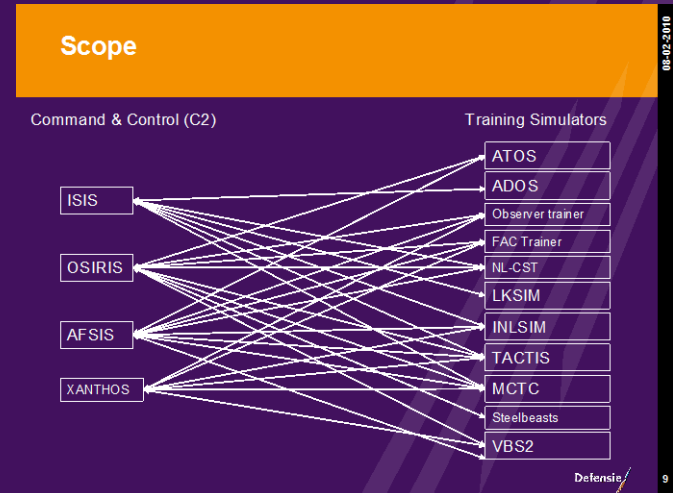

User Requirements for the TACTIS situation



1. Common Operational Picture

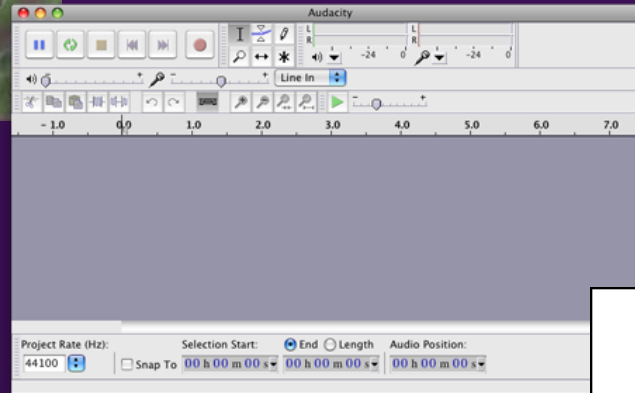

2. Simulation and C2 system control

3. Plans and orders

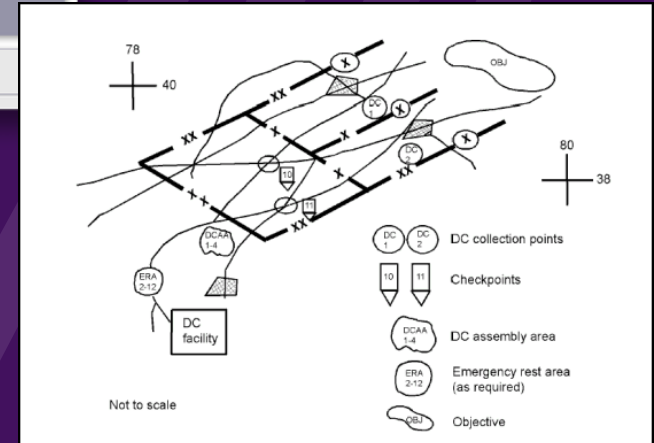

Standards under development

Take into account (long-term)

- MSDL (for initialization of simulations)
- C-BML (plans and orders)

Experience with existing C2 – Sim coupling



Result in AFSIS: COP, Fire support reports



Result in MCTC is AAR data for instructors

- COP (Perceived truth as seen by players)
- Ground truth (from MCTC)

What is a Datamapper

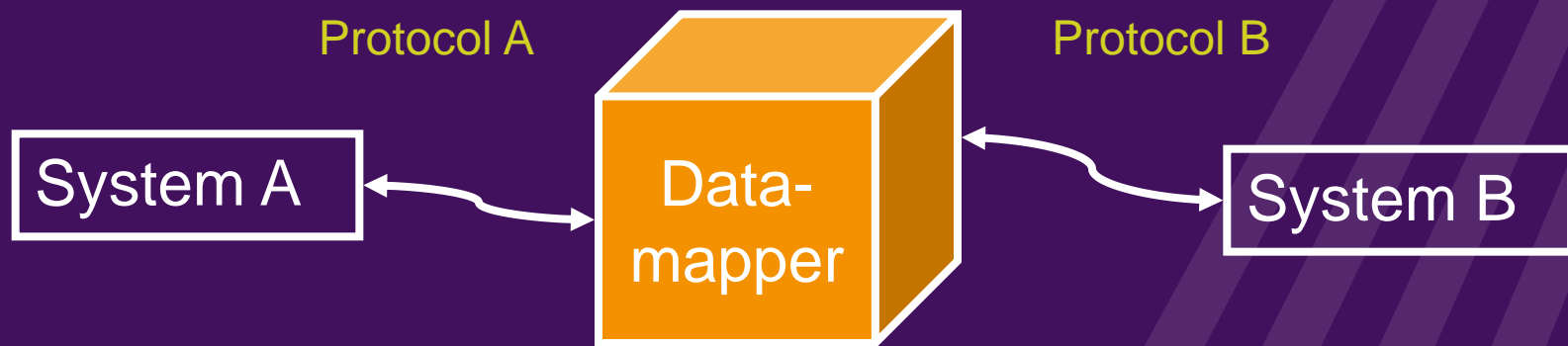

WISE, a typical COTS Datamapper

Claimed capabilities

- **Standard protocols** HLA 1516(Pitch, MÄK, NG), HLA 1.3(GERTICO, MÄK), DIS, MIP (Multilateral Interoperability program C2IEDM), Link 16, Google Earth/Maps, Web Services
- **Proprietary protocols** WISE SecureSocket, SAFIR DOB, (Saab C2-C4), PDU 2.0 (Saab TES), WCU (Saab Civilian C2), OneSAF, BattleTek, Saab Gizmo Distribution, SQL Server, LinkZA, RBS 70 (SBD), Enemy Territory, Microsoft Combat FS
- **Future** Link 11, Link 22, C-BML, TENA, PDU 3.0, DDS, MIP(JC3IEDM), HLA Evolved, MATREX RTI, RTI NG Pro, CoT

Benefits

- Automatic connections
- User defined connections
- Analyzing and testing
- No modifications are needed

Disadvantages

- Stuck to one manufacturer
- No NLD experience with all capabilities
- Some problems can't be solved by datamapping

Conclusions wrt COTS datamapper

- Positive experience with (COTS) datamapper
- Not all required standards implemented yet
- Use of operational C2 systems can be supported for COP
- Simulation and C2 systems control cannot be supported
- Plans and Orders to Constructive sims cannot be supported

Short Term Recommendations

1. Use a Phased Approach
 - Phase 1 Common Operational Picture
 - Phase 2 Logging and AAR
 - Phase 3 Exchange of orders and plans
2. Acquisition and use of the WISE COTS datamapper

Result after phase 1

- An acceptable initial solution for TACTIS
 - An first step to a solution for other systems
 - Short term, does not contradict BML standard under development
3. More experiments with existing systems (C2, CST, TACTIS)
 4. Analyzing user requirements for C2 systems wrt DSS

TACTIS coupling

Current situation



TACTIS coupling

Current situation with C2 added

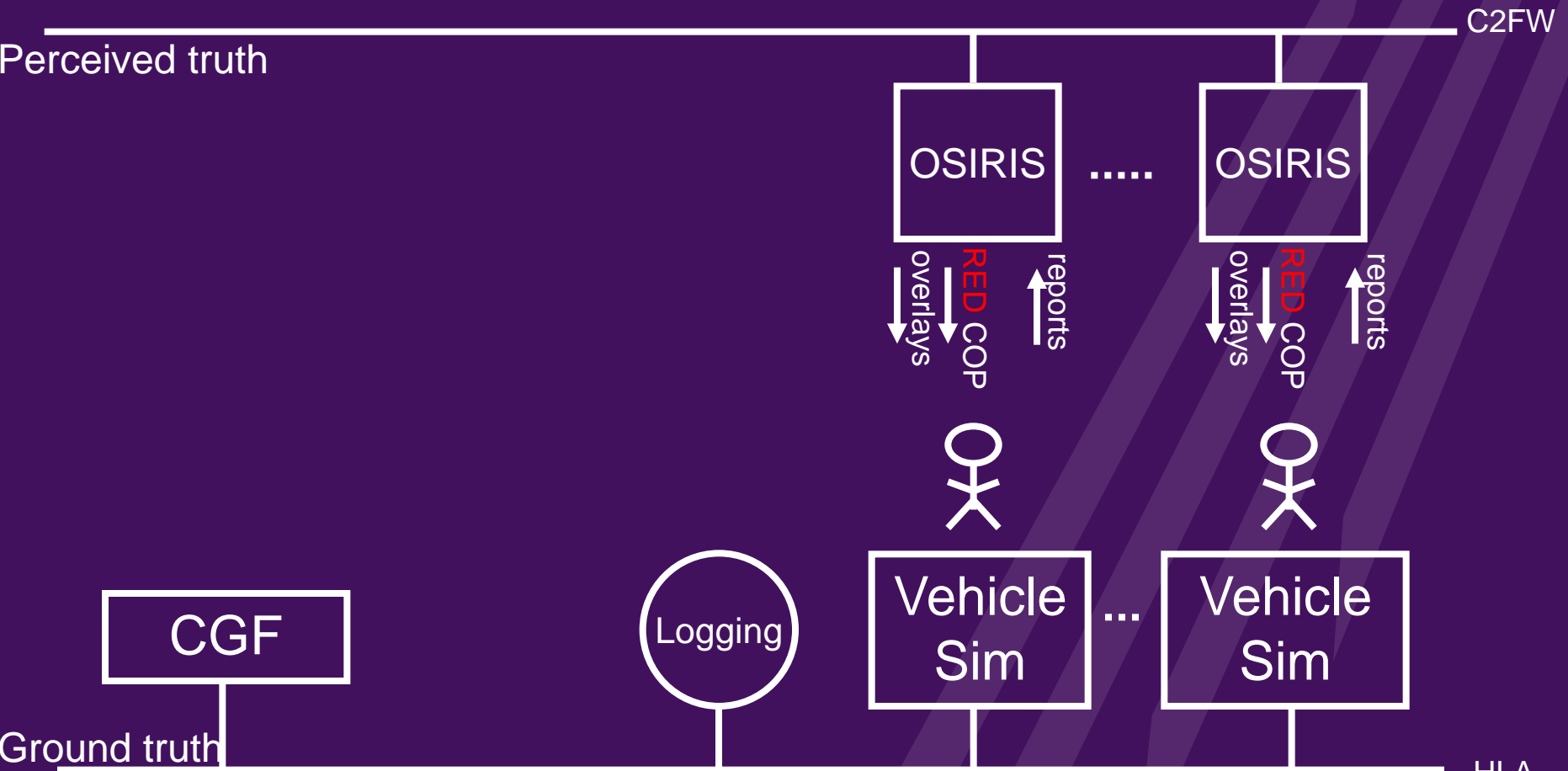

Only Red COP from blue Virtuals in OSIRIS

TACTIS coupling (phase 1)

Possible solution with C2 systems (for virtuals)

No communications effects simulated in phase 1

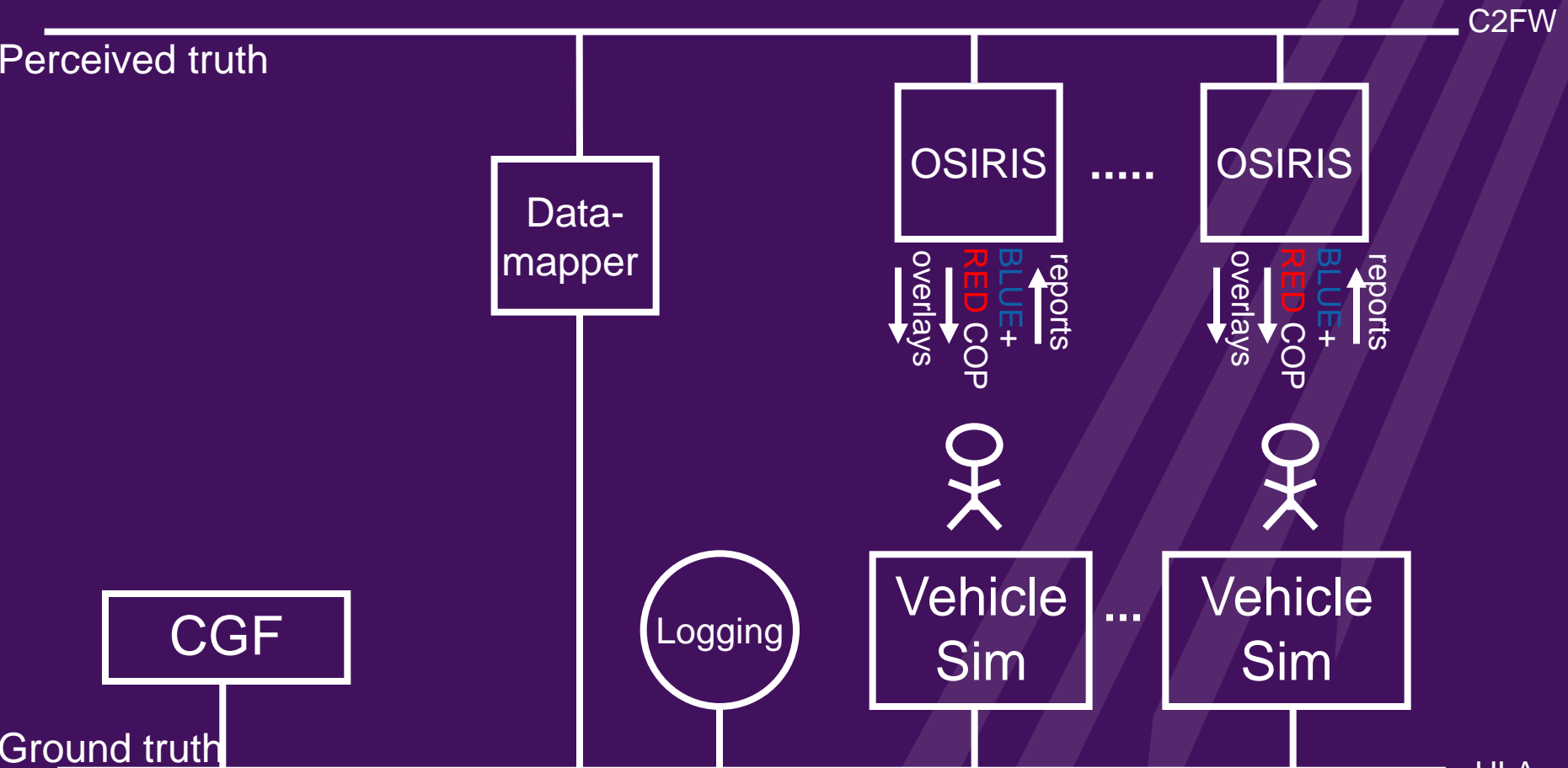

Red+blue COP from blue Virtuals in OSIRIS
Blue COP from blue Constructives in OSIRIS

TACTIS coupling (phase 2B)

Red COP from CGFs added

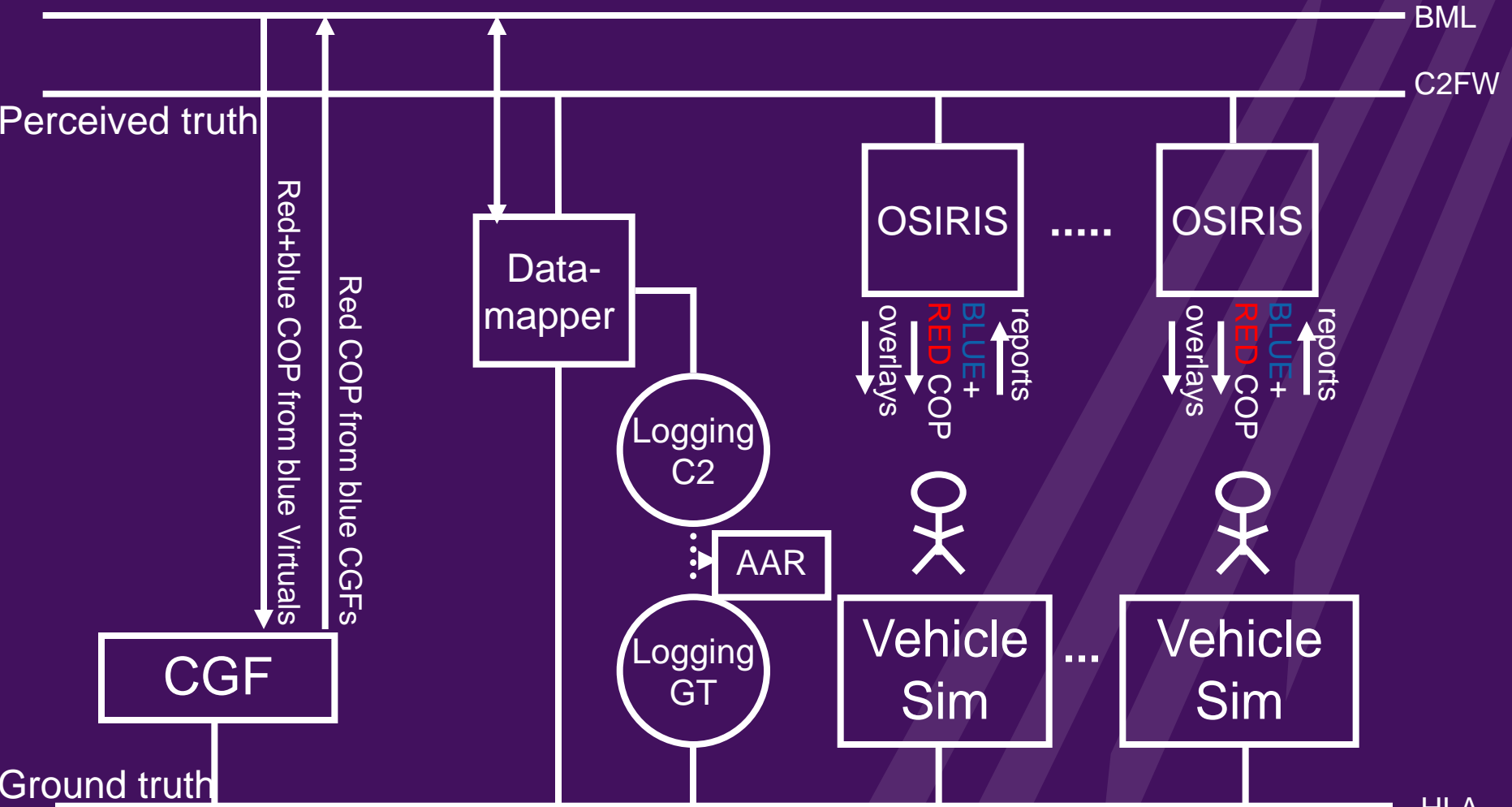

Red+blue COP from blue Virtuals in OSIRIS
Red+blue COP from blue Constructives in OSIRIS

TACTIS coupling (phase 3)

Plans/Orders to Constructives added

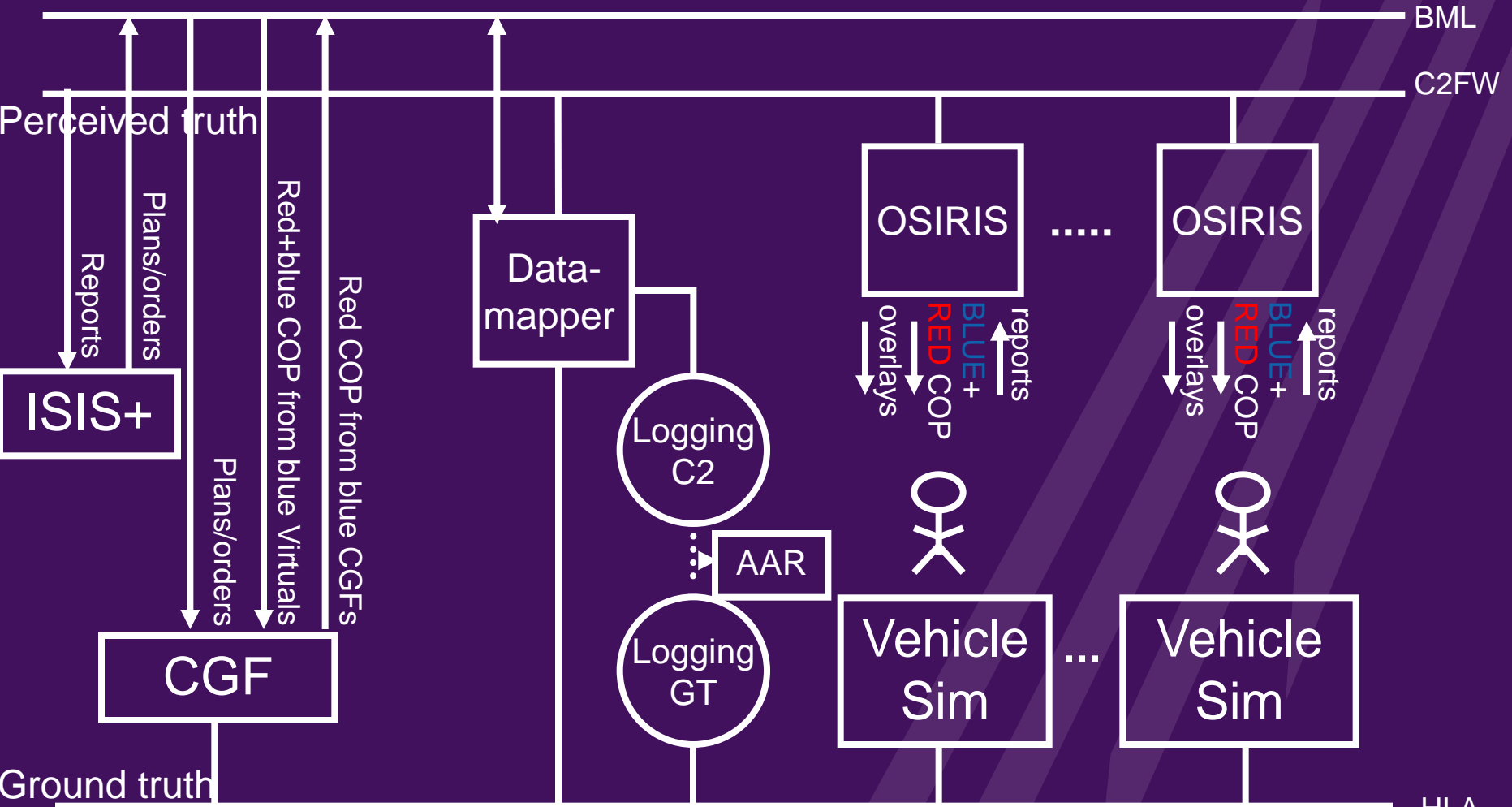

Red+blue COP from blue Virtuals in OSIRIS
Red+blue COP from blue Constructives in OSIRIS

TACTIS coupling (long term)

BML for all tactical data, removal of datamapper

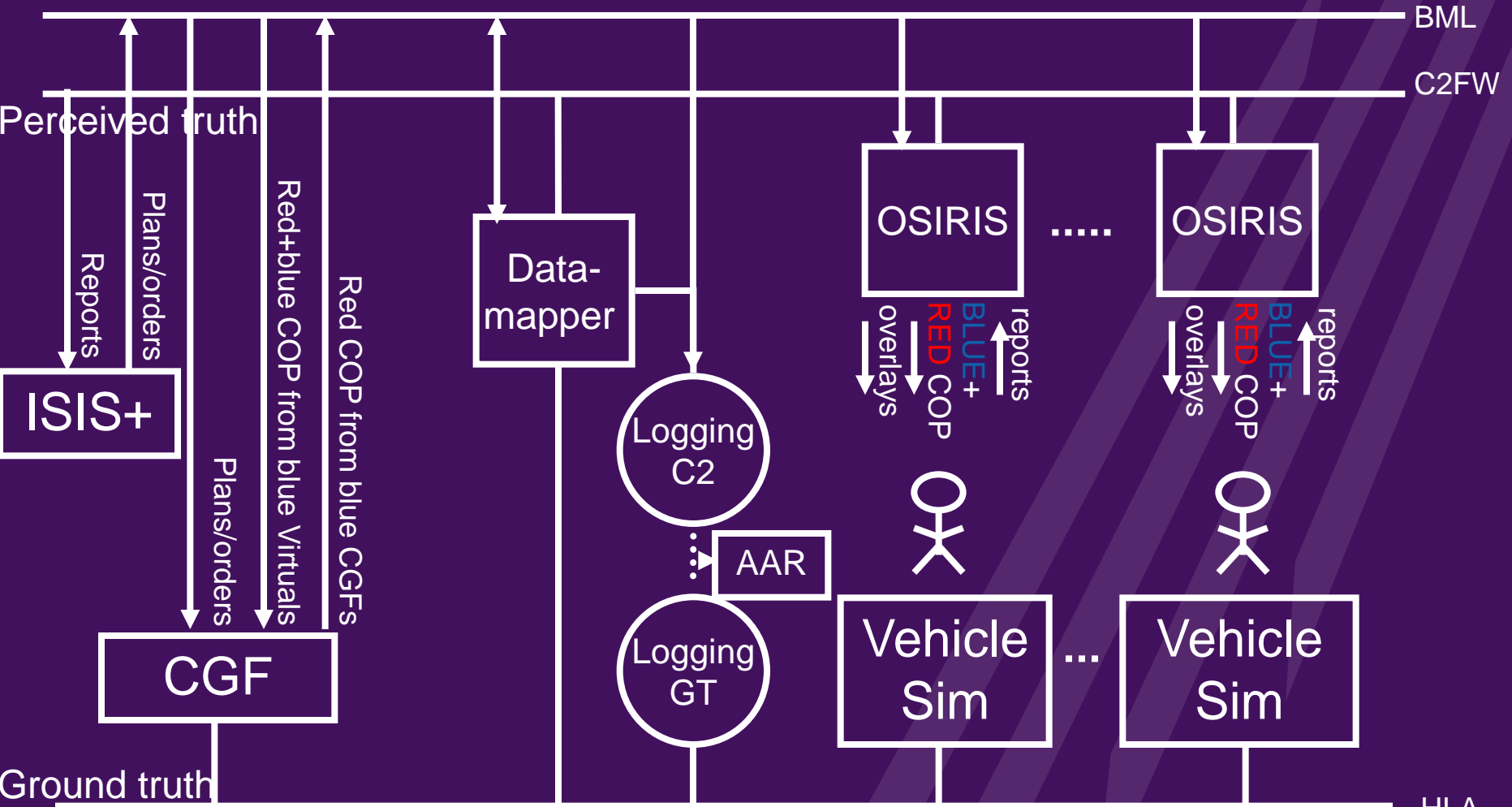

Red+blue COP from blue Virtuals in OSIRIS

Red+blue COP from blue Constructives in OSIRIS

BML

C2FW

HLA

TACTIS coupling (long term)

Integration of BML in tactical datalink

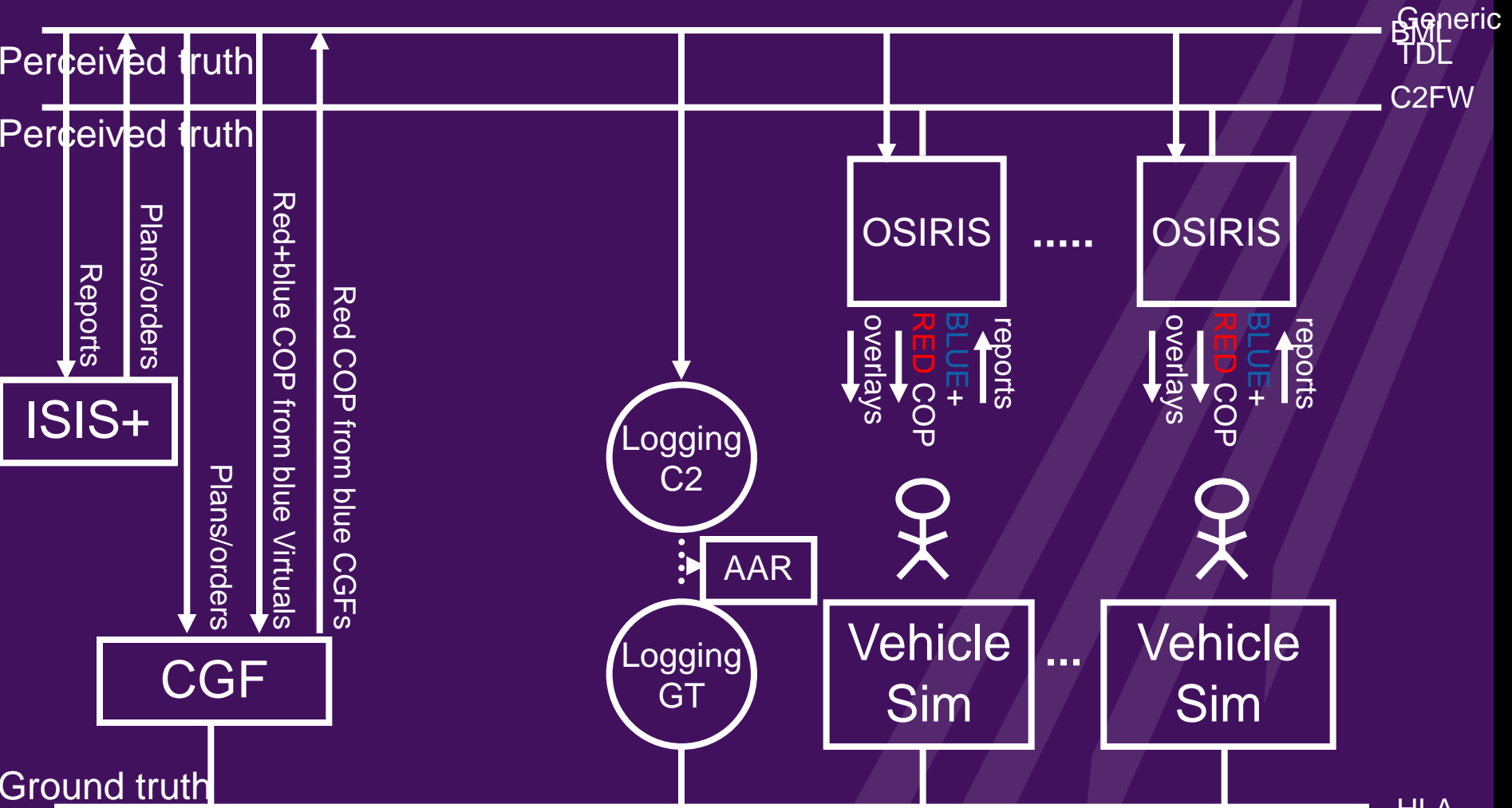

Red+blue COP from blue Virtuals in OSIRIS
 Red+blue COP from blue Constructives in OSIRIS

Long Term challenges

In order for C-BML to satisfy Training, Mission Rehearsal and Decision Making requirements the following challenges must be overcome

- Simulation + C2 system control problem must be solved (within or outside BML)
- All C2 and Simulator systems must understand C-BML
- C-BML must not only be human readable but must unambiguously be transformable to an overlay
- BML and existing tactical datalinks (like the NLD MIP based C2FW) must be integrated in the end

End



Questions ??