



# Experimental Investigation of Piston Heat Transfer in a Light Duty Engine Under Conventional Diesel, Homogeneous Charge Compression Ignition, and Reactivity Controlled Compression Ignition Combustion Regimes



***Eric Gingrich\****, ***Rolf Reitz\*\****, ***Jaal Ghandhi\*\****

***\*Now affiliated with U.S. Army TARDEC***

***\*\* University of Wisconsin-Madison***

***Sandia National Laboratory***

***Advanced Engine Combustion Meeting***

***February 13, 2014***

## Acknowledgments

DoD SMART Scholarship  
DERC Member Companies  
Office of Naval Research

# Report Documentation Page

*Form Approved  
OMB No. 0704-0188*

Public reporting burden for the collection of information is estimated to average 1 hour per response, including the time for reviewing instructions, searching existing data sources, gathering and maintaining the data needed, and completing and reviewing the collection of information. Send comments regarding this burden estimate or any other aspect of this collection of information, including suggestions for reducing this burden, to Washington Headquarters Services, Directorate for Information Operations and Reports, 1215 Jefferson Davis Highway, Suite 1204, Arlington VA 22202-4302. Respondents should be aware that notwithstanding any other provision of law, no person shall be subject to a penalty for failing to comply with a collection of information if it does not display a currently valid OMB control number.

1. REPORT DATE <b>13 FEB 2014</b>		2. REPORT TYPE <b>Briefing Charts</b>		3. DATES COVERED <b>14-01-2014 to 07-02-2014</b>	
4. TITLE AND SUBTITLE <b>Experimental Investigation of Piston Heat Transfer in a Light Duty Engine Under Conventional Diesel, Homogeneous Charge Compression Ignition, and Reactivity Controlled Compression Ignition Combustion Regimes</b>				5a. CONTRACT NUMBER	
				5b. GRANT NUMBER	
				5c. PROGRAM ELEMENT NUMBER	
6. AUTHOR(S) <b>Eric Gengrich; Rolf Reitz; Jaal Ghandhi</b>				5d. PROJECT NUMBER	
				5e. TASK NUMBER	
				5f. WORK UNIT NUMBER	
7. PERFORMING ORGANIZATION NAME(S) AND ADDRESS(ES) <b>University of Wisconsin-Madison, 500 Lincoln Dr, Madison, WI, 53706</b>				8. PERFORMING ORGANIZATION REPORT NUMBER <b>; #24446</b>	
9. SPONSORING/MONITORING AGENCY NAME(S) AND ADDRESS(ES) <b>U.S. Army TARDEC, 6501 East Eleven Mile Rd, Warren, Mi, 48397-5000</b>				10. SPONSOR/MONITOR'S ACRONYM(S) <b>TARDEC</b>	
				11. SPONSOR/MONITOR'S REPORT NUMBER(S) <b>#24446</b>	
12. DISTRIBUTION/AVAILABILITY STATEMENT <b>Approved for public release; distribution unlimited</b>					
13. SUPPLEMENTARY NOTES <b>Presented to Advanced Engine Combustion Meeting with Sandia National Laboratory</b>					
14. ABSTRACT <b>Briefing Charts</b>					
15. SUBJECT TERMS					
16. SECURITY CLASSIFICATION OF:			17. LIMITATION OF ABSTRACT <b>Public Release</b>	18. NUMBER OF PAGES <b>29</b>	19a. NAME OF RESPONSIBLE PERSON
a. REPORT <b>unclassified</b>	b. ABSTRACT <b>unclassified</b>	c. THIS PAGE <b>unclassified</b>			



# Outline

UNCLASSIFIED



- Experimental Setup
- Data Processing
- Results
- Summary / Conclusion

UNCLASSIFIED



## Purpose

UNCLASSIFIED



- To investigate heat flux in multiple LTC modes and compare to CDC
- The results presented seek to add understanding to an important difference between LTC and CDC which is heat transfer
- HCCI and RCCI are the LTC strategies investigated in this study

UNCLASSIFIED



# Experimental Setup



UNCLASSIFIED

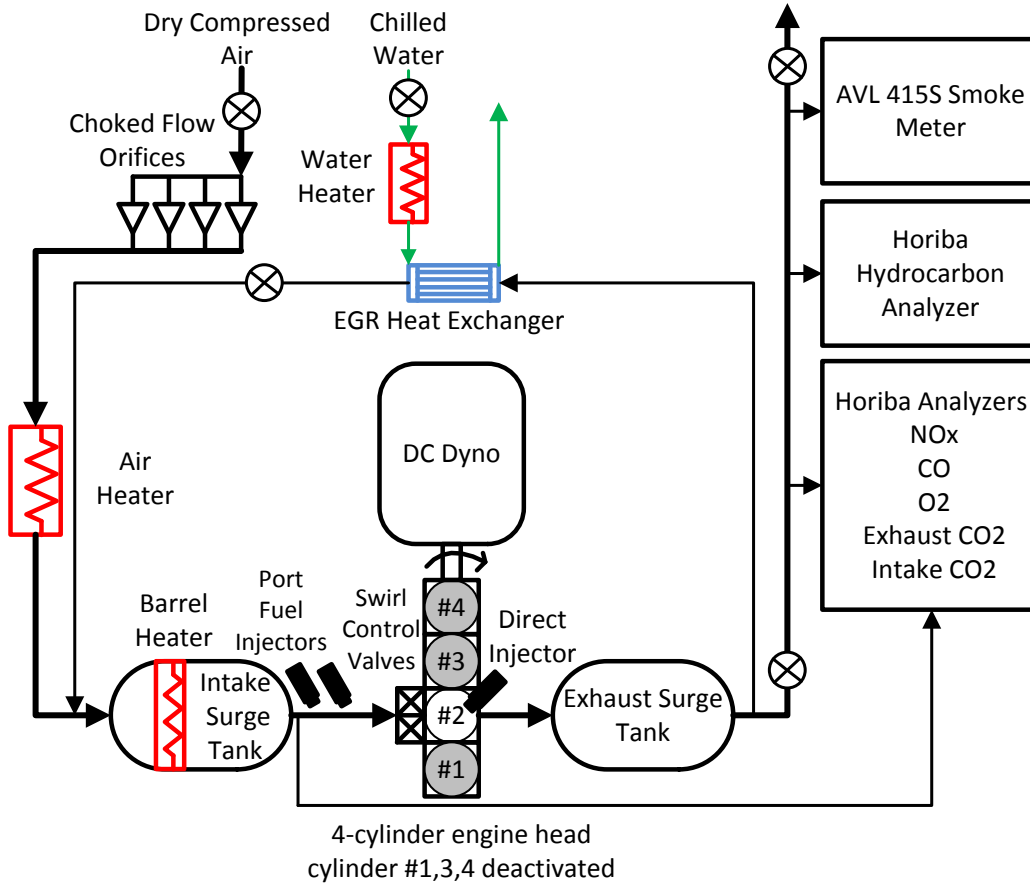

<b>Engine Geometry</b>	
Base Engine	GM 1.9L Diesel
Compression Ratio	16.3
Displacement (Liters)	0.477
Stroke (mm)	90.4
Bore (mm)	82
Intake Valve Closing	-132° aTDC
Exhaust Valve Opening	112° aTDC
Swirl Ratio	1.5 -4.8
Piston Bowl Type	Stock (Re-entrant)
<b>Port Fuel Injectors</b>	
Included Spray Angle	20°
Injection Pressure (bar)	2 to 10
Rated Flow (cc/sec)	< 10
<b>Bosch Common Rail Injector</b>	
Number of Holes	7
Hole Diameter (mm)	0.14
Included Spray Angle	155°
Injection Pressure (bar)	250 to 1000 bar

UNCLASSIFIED



U.S. ARMY  
**RDECOM**  
TECHNOLOGY DRIVEN. WARFIGHTER FOCUSED.

# Experimental Setup



UNCLASSIFIED

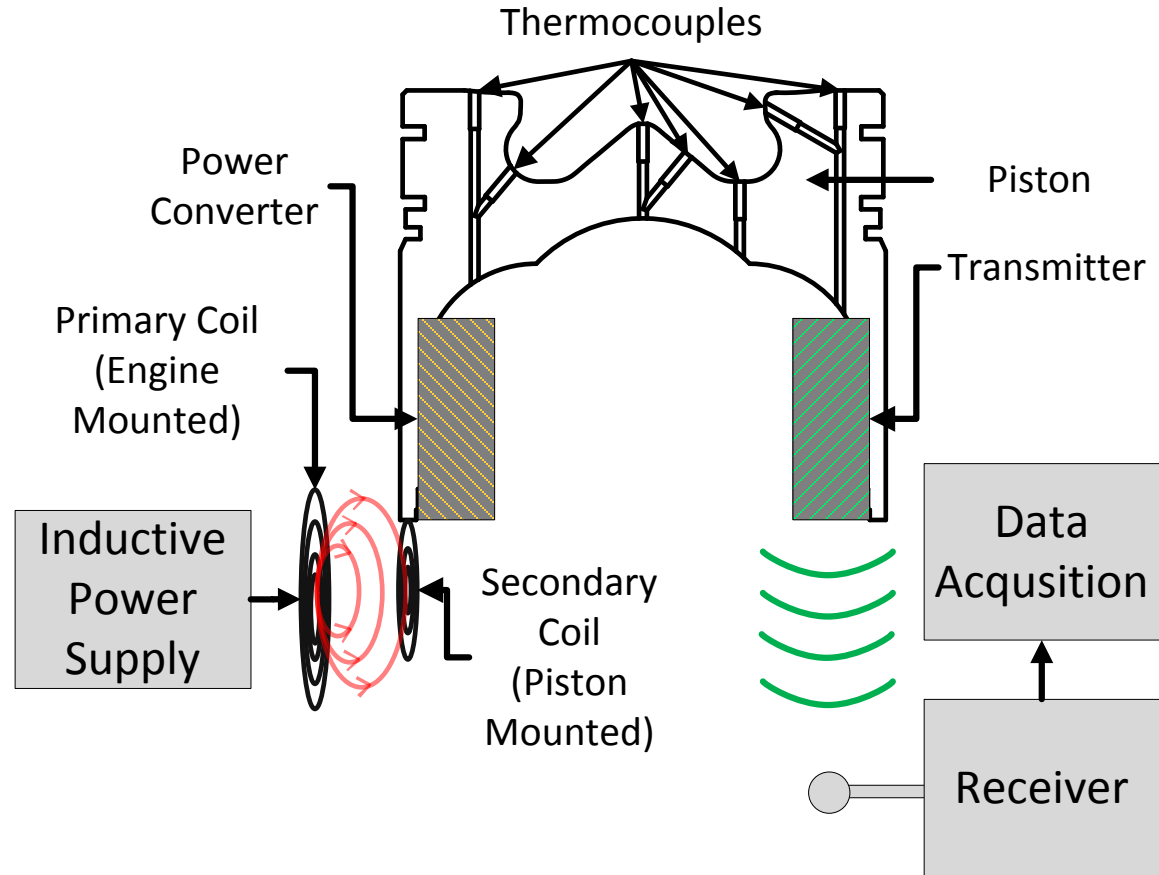
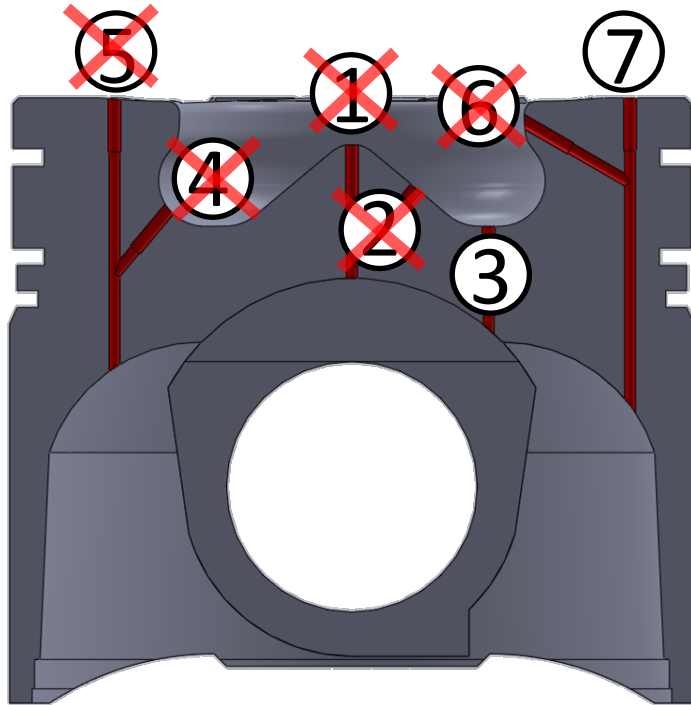

UNCLASSIFIED

- At each crank-angle an outliers test is performed using the Generalized ESD Test for Outliers (Rosner 1983)
  - Statistical test
  - Assumes data has normal distribution
  - Allows for rejection of multiple outliers

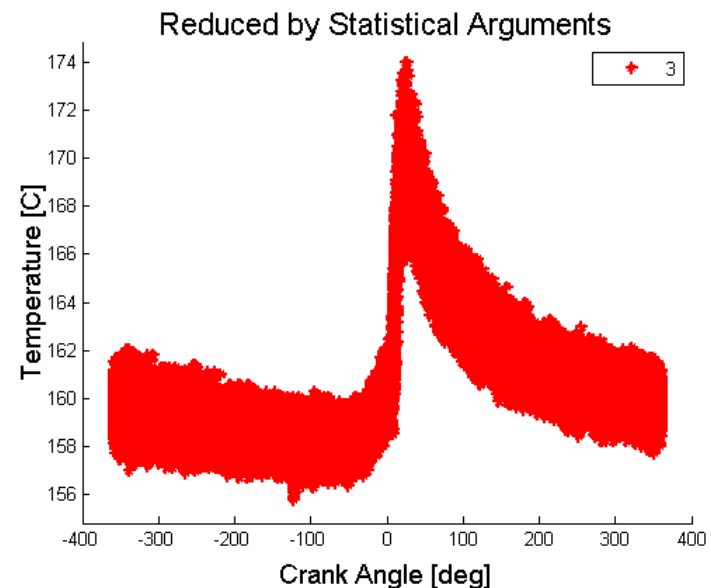
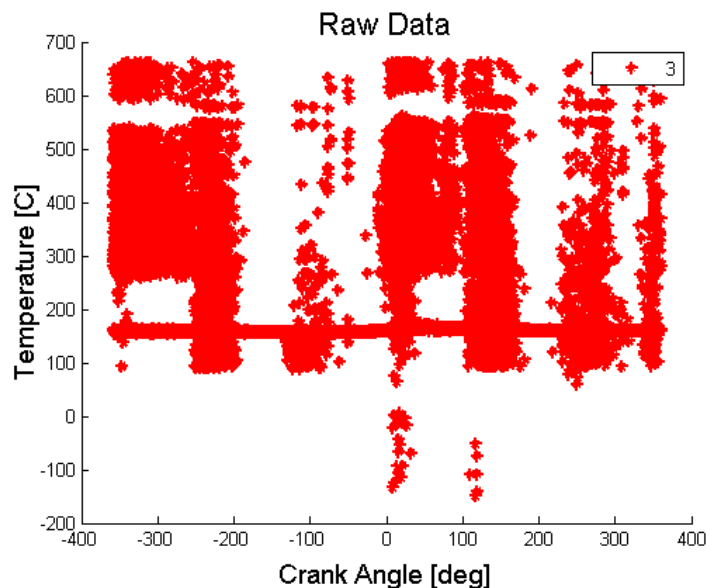

- Mean temperature data are relatively clean
- Temperature data are filtered with 2000Hz low pass filter
- Fourier analysis is applied to find heat flux
- Integral of the dynamic heat flux over the full cycle is zero, but for the closed portion of the cycle it is meaningful

$$T(t) = T_m + \sum [A_n \cos(n\omega t) + B_n \sin(n\omega t)] \rightarrow \dot{q} = \frac{k}{l} (T_m - T_l) + k \sum_{n=1}^N \sqrt{\frac{n\omega}{2\alpha}} [(A_n + B_n) \cos(n\omega t) - (A_n - B_n) \sin(n\omega t)]$$

Steady Dynamic

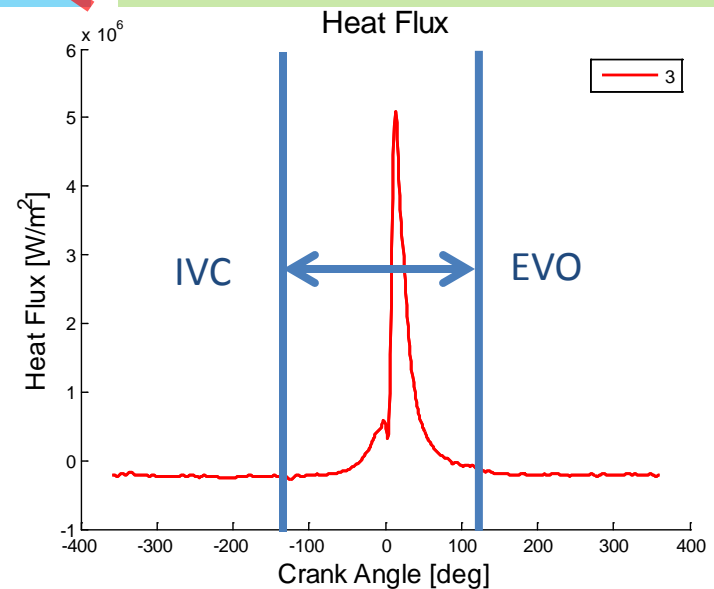
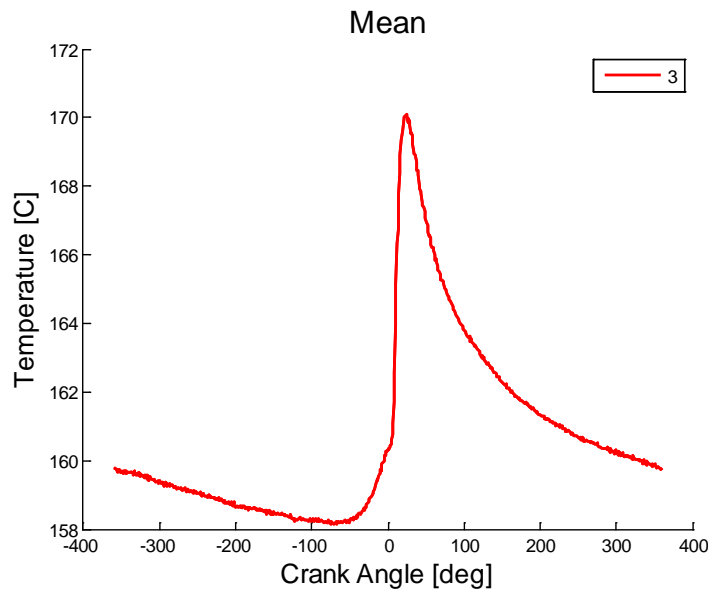



## Combustion Strategy Effect

### CDC / HCCI / RCCI

	Mode 1	Mode 2	Mode 3	Mode 4
Speed (RPM)	1490	1900	2300	2300
IMEPg (bar)	4.2	5.7	5.7	8
CA50 (degATDC)	4	5	4.5	8
Swirl	1.5	1.5	1.5	1.5
Intake Temperature (C)	75	50	50	35
Intake Pressure (kPa)	115	130	130	188
ERG (%)	0	0	0	55

## Combustion Phasing Effect

	Mode 2
Speed (RPM)	1900
IMEPg (bar)	5.7
CA50 (degATDC)	3, 5, 7, 9
Swirl	1.5
Intake Temperature (C)	50
Intake Pressure (kPa)	130
EGR (%)	0

## Swirl Effect

	Mode 2
Speed (RPM)	1900
IMEPg (bar)	5.7
CA50 (degATDC)	5
Swirl	1.5, 2.5, 3.5, 4.8
Intake Temperature (C)	50
Intake Pressure (kPa)	130
EGR (%)	0

## Fuels

Regime	Fuel
HCCI	91PON Gasoline / n-heptane
RCCI	F76 / 91PON Gasoline
CDC	F76

# Mode 1

4.2 bar IMEPg  
4 degATDC CA50  
1490 RPM

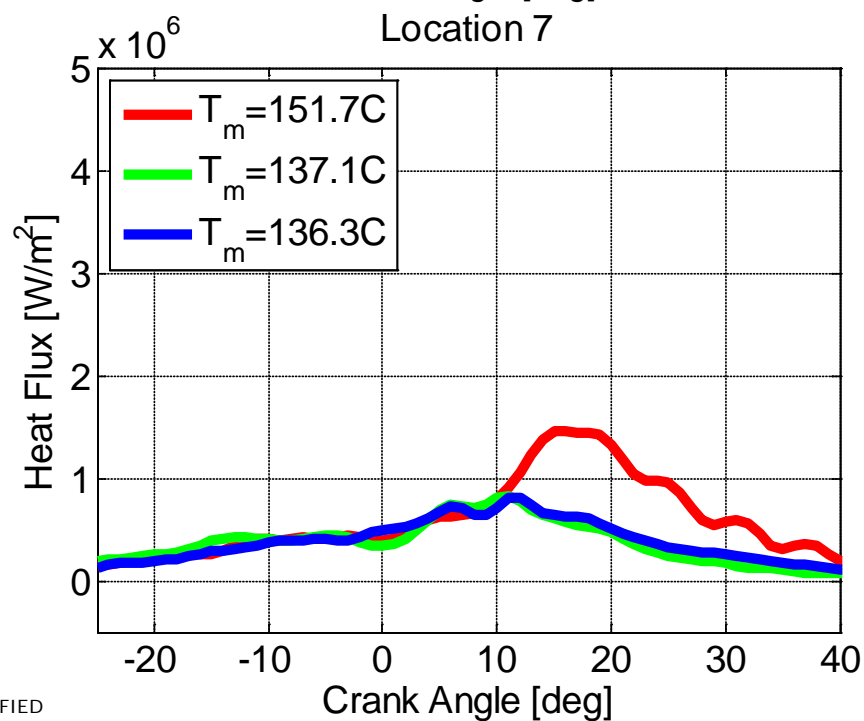
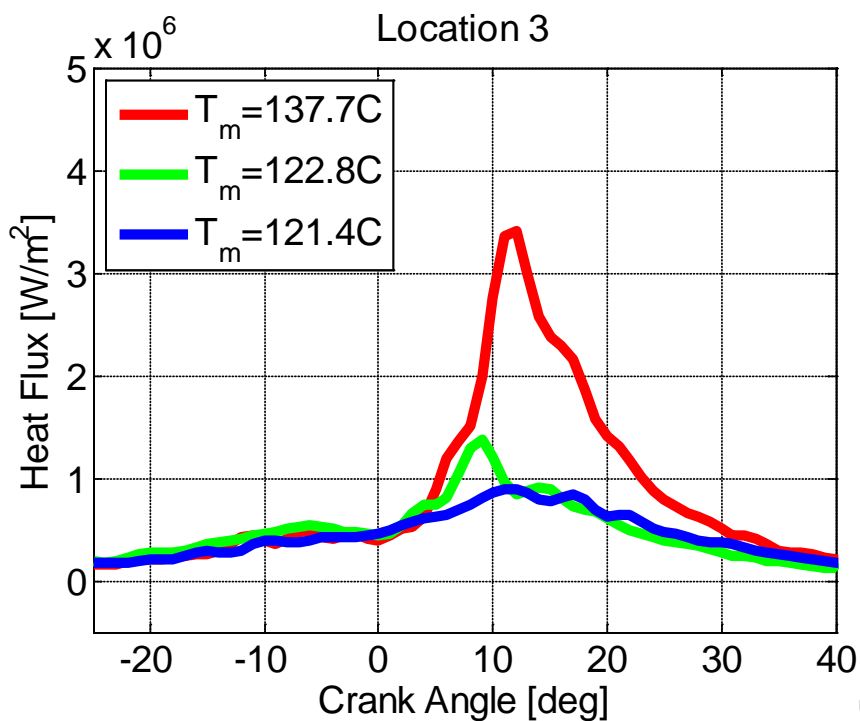
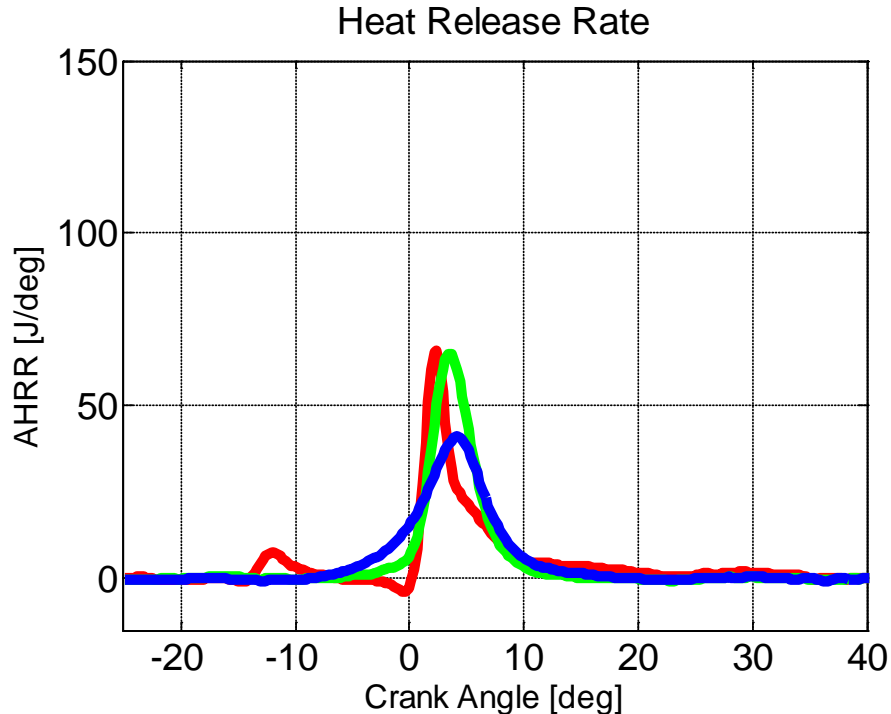
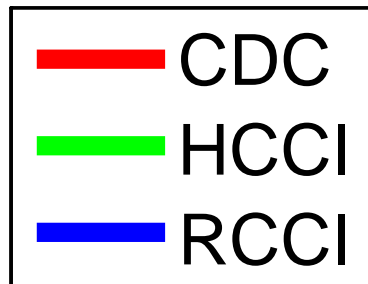

# Mode 2

5.7 bar IMEPg  
5 degATDC CA50  
1900 RPM

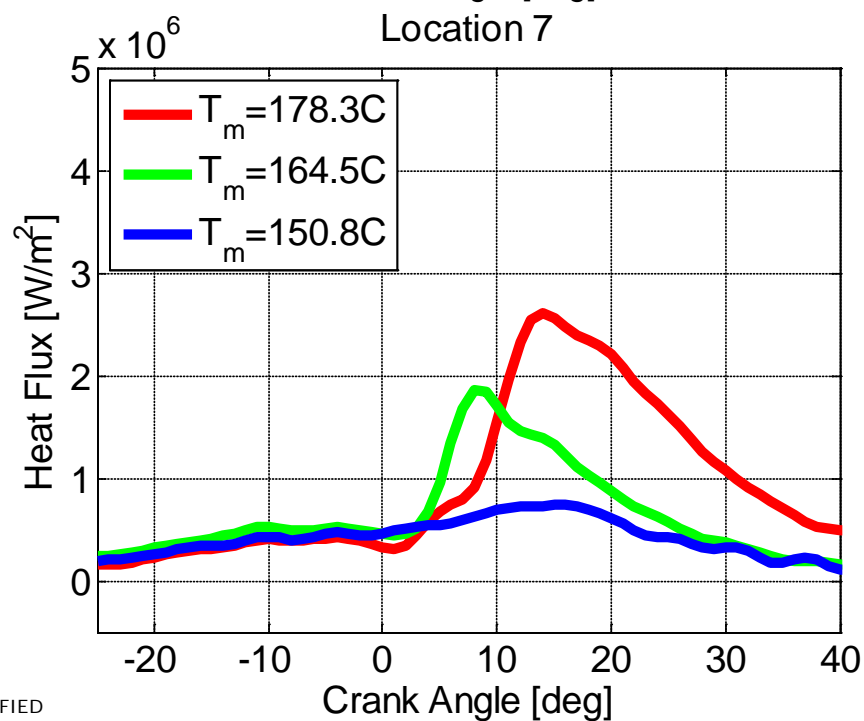
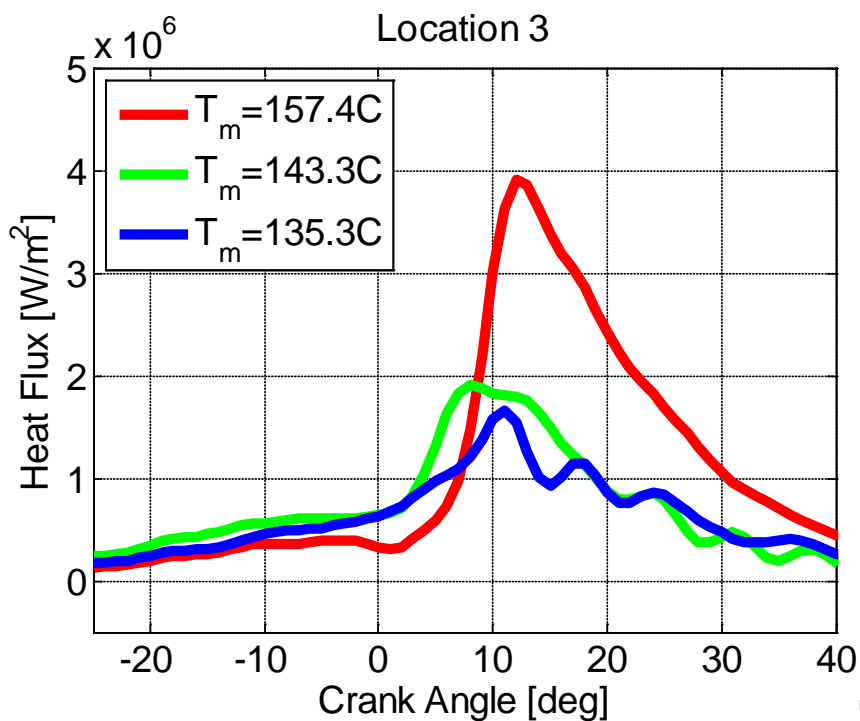
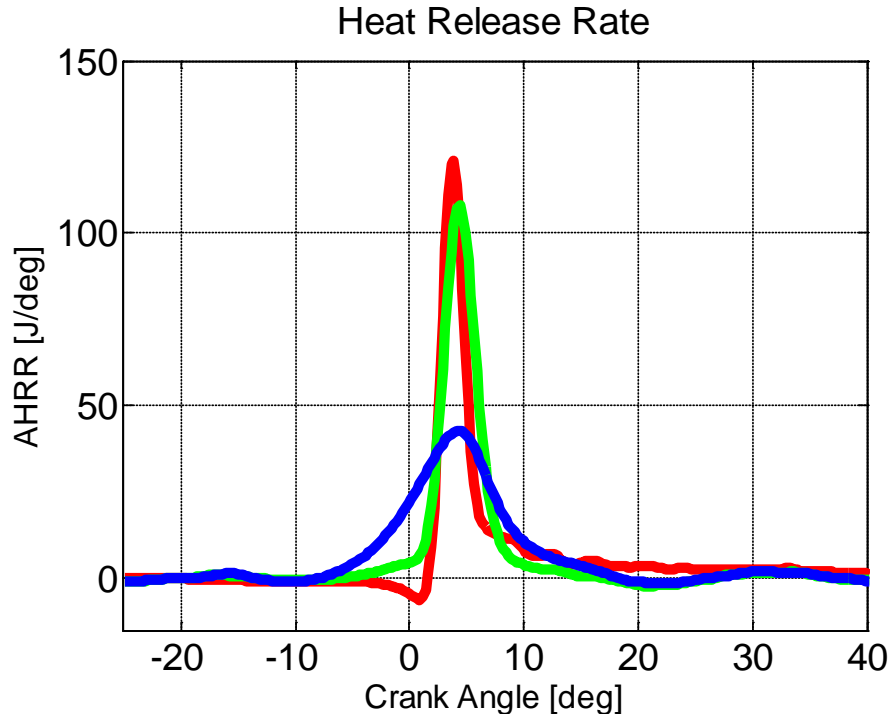
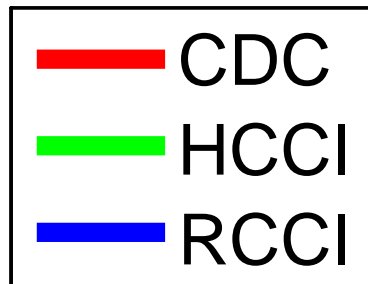

# Mode 3

5.7 bar IMEPg  
5 degATDC CA50  
2300 RPM

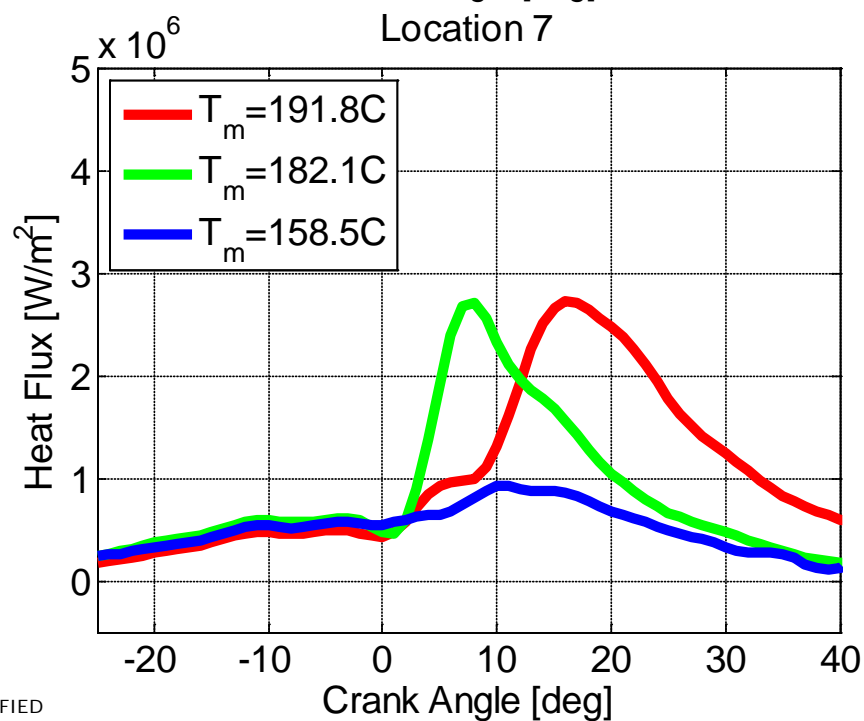
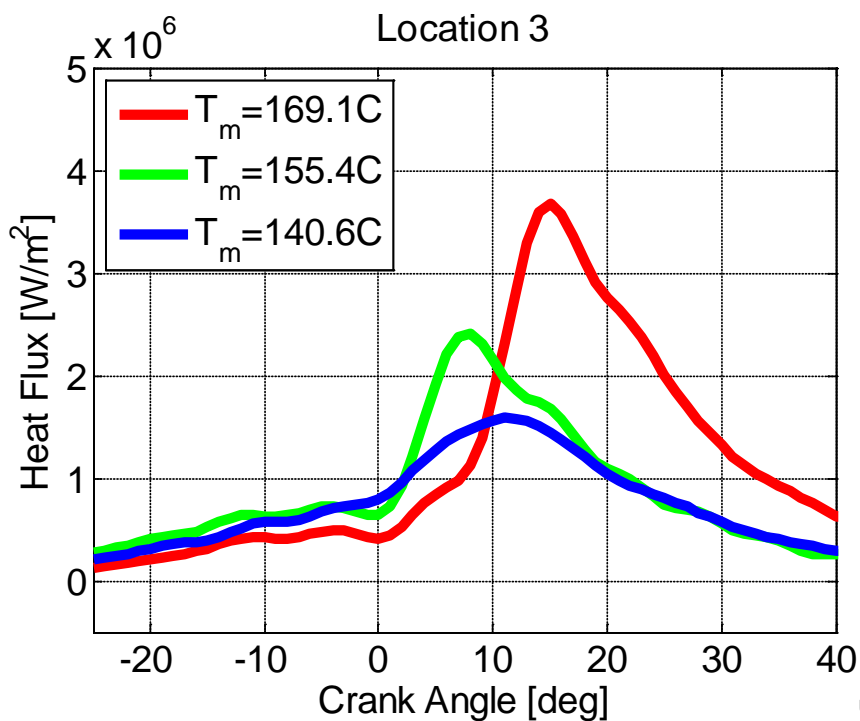
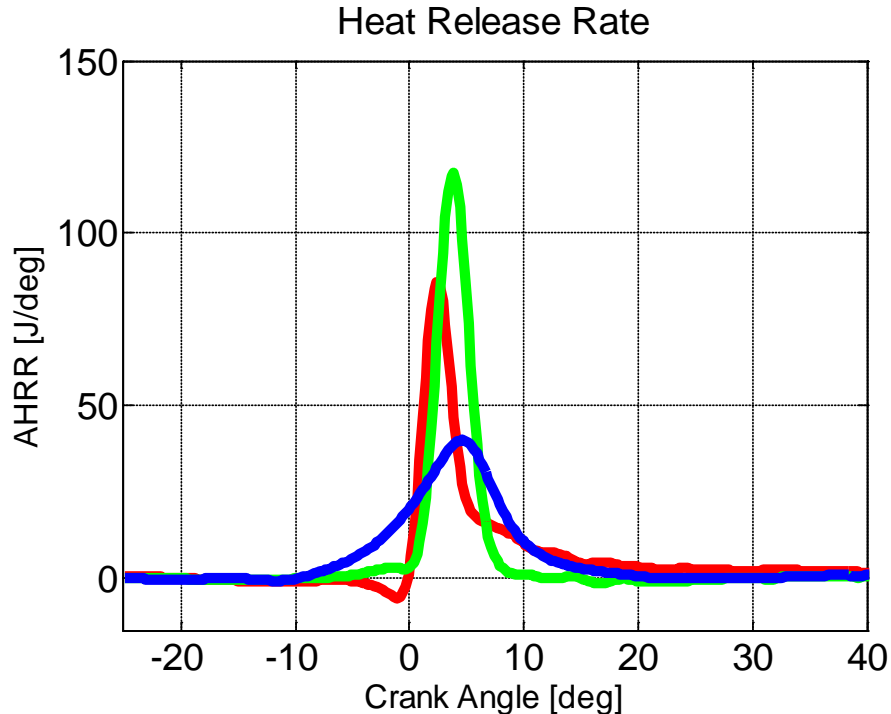
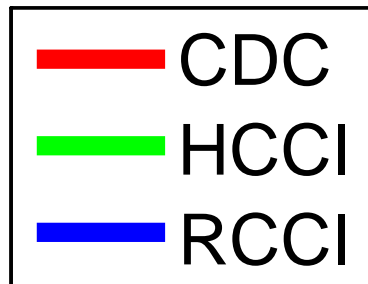

# Mode 4

8 bar IMEPg

8 degATDC CA50

2300 RPM

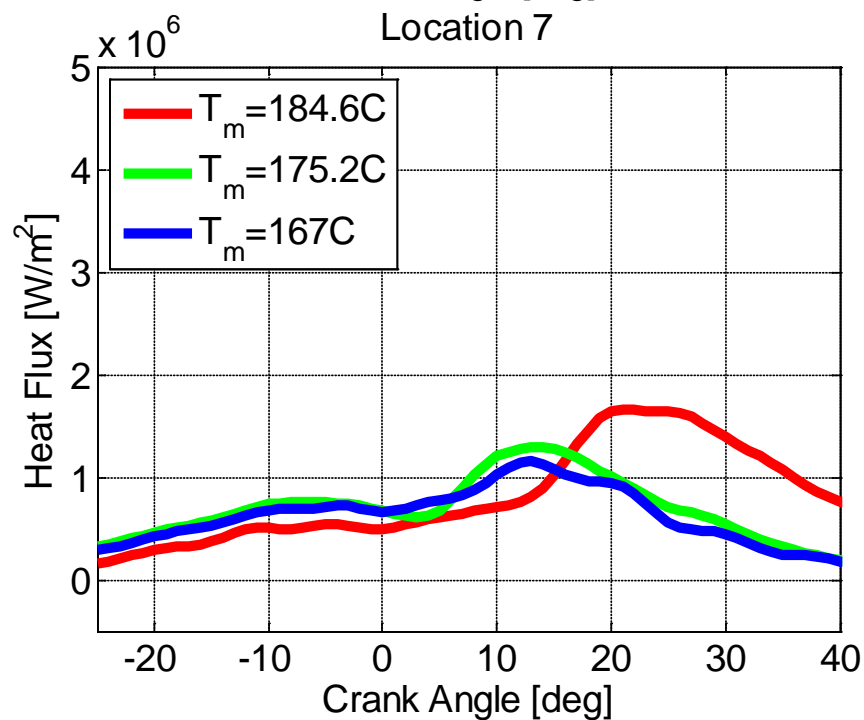
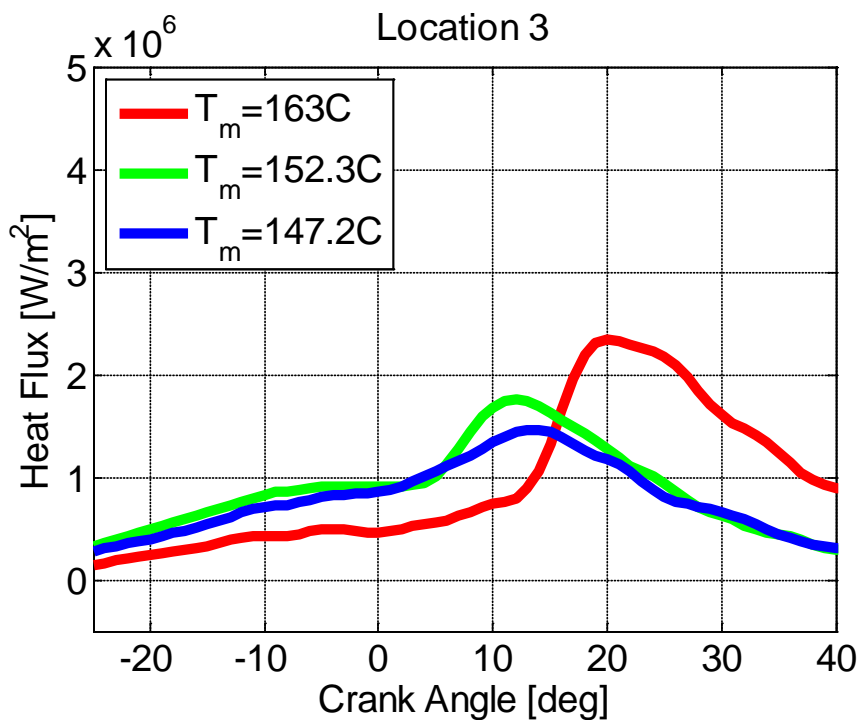
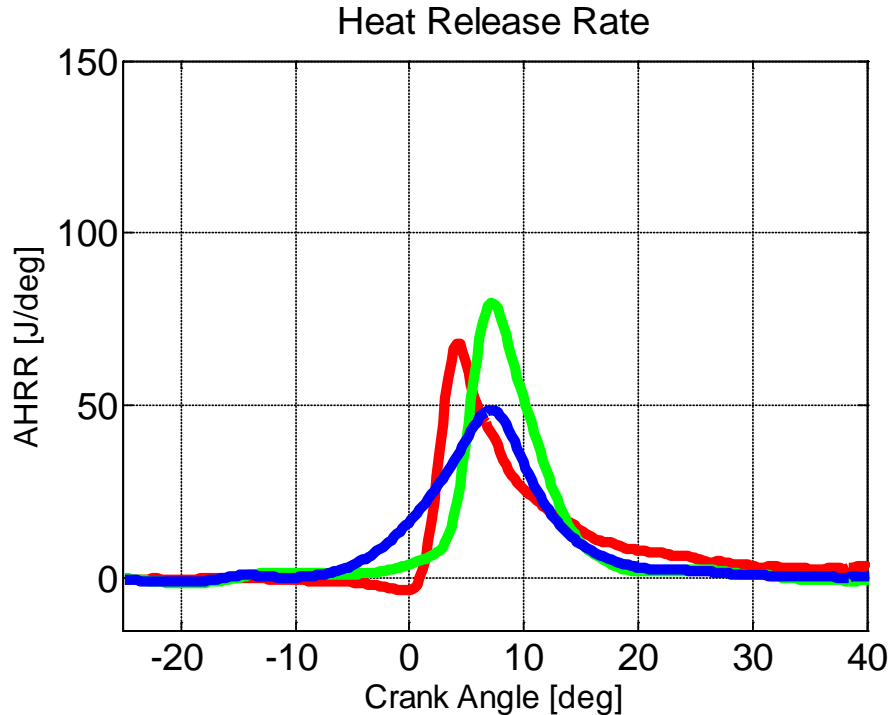
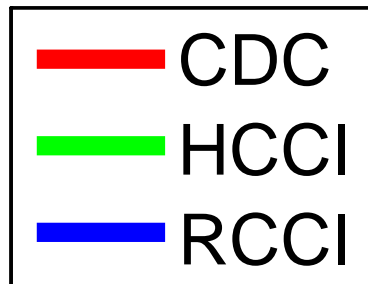



U.S. ARMY  
**RDECOM**  
TECHNOLOGY DRIVEN. AIRFIGHTER FOCUSED.

# Closed-cycle Integrated Heat Flux



UNCLASSIFIED

### Location 3

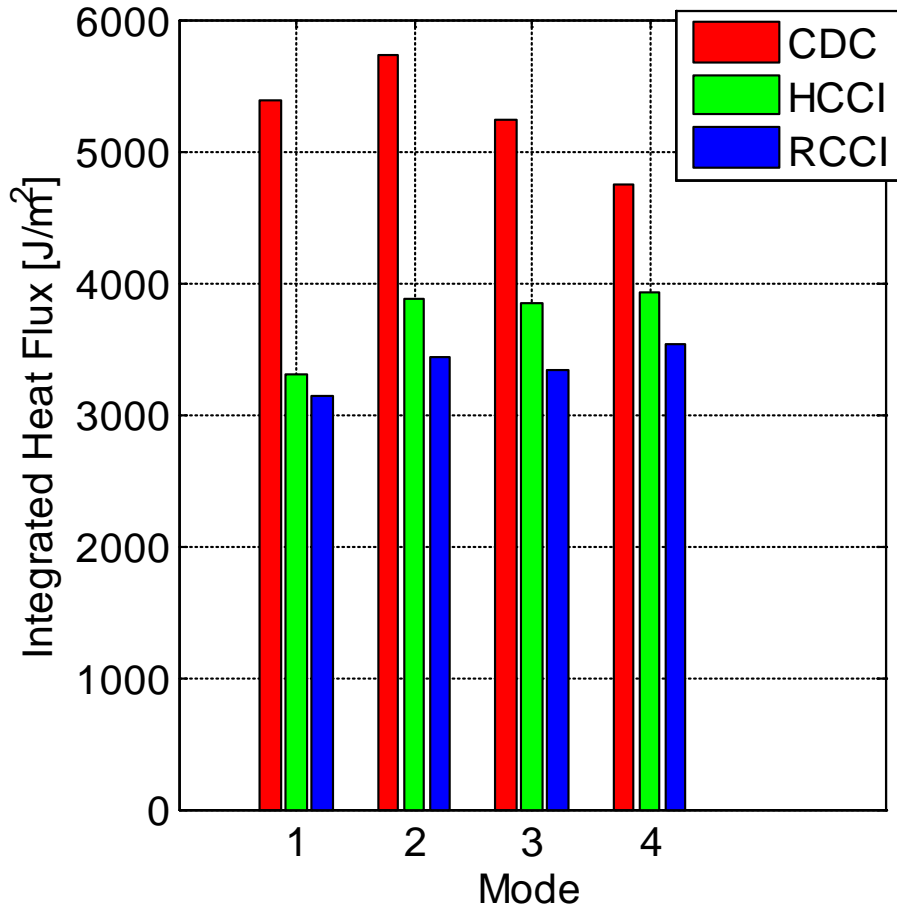

### Location 7

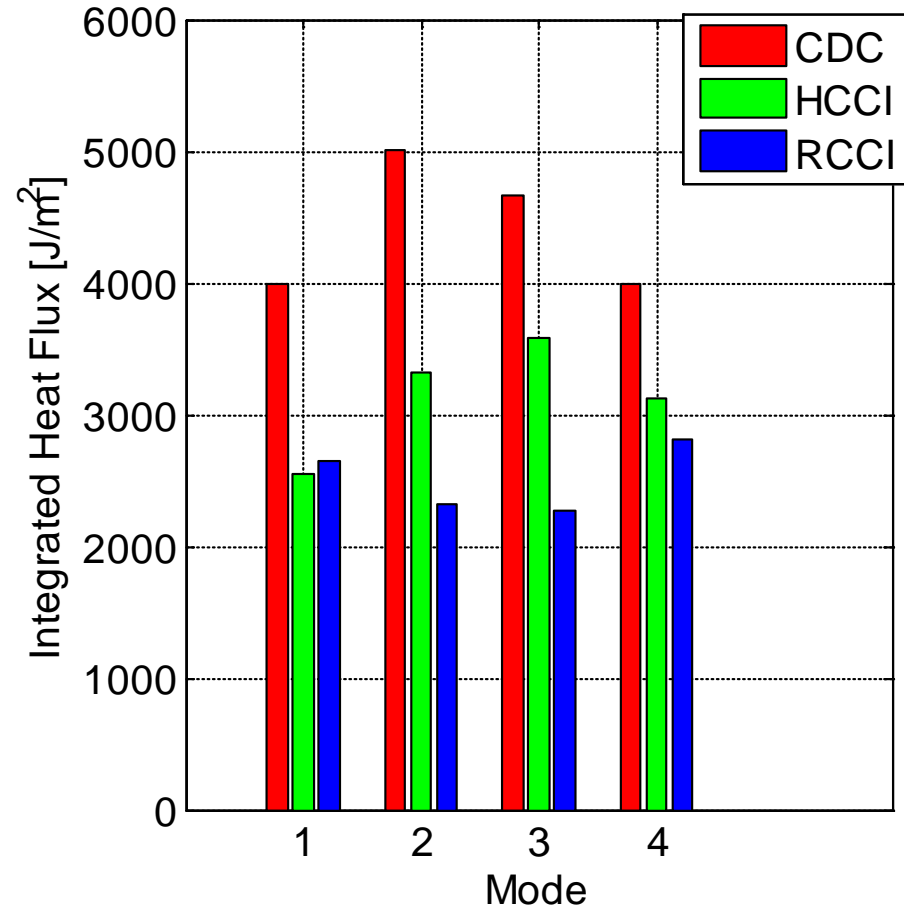

UNCLASSIFIED

# CDC CA50 Sweep

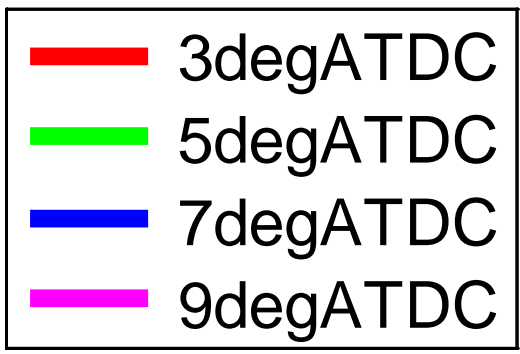

Fixed 5.7bar IMEPg

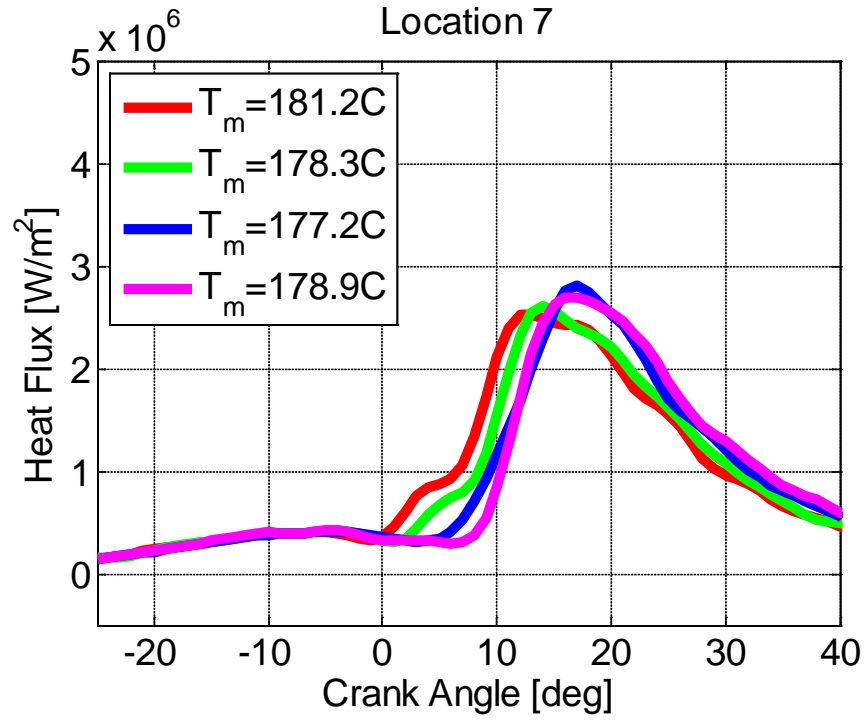
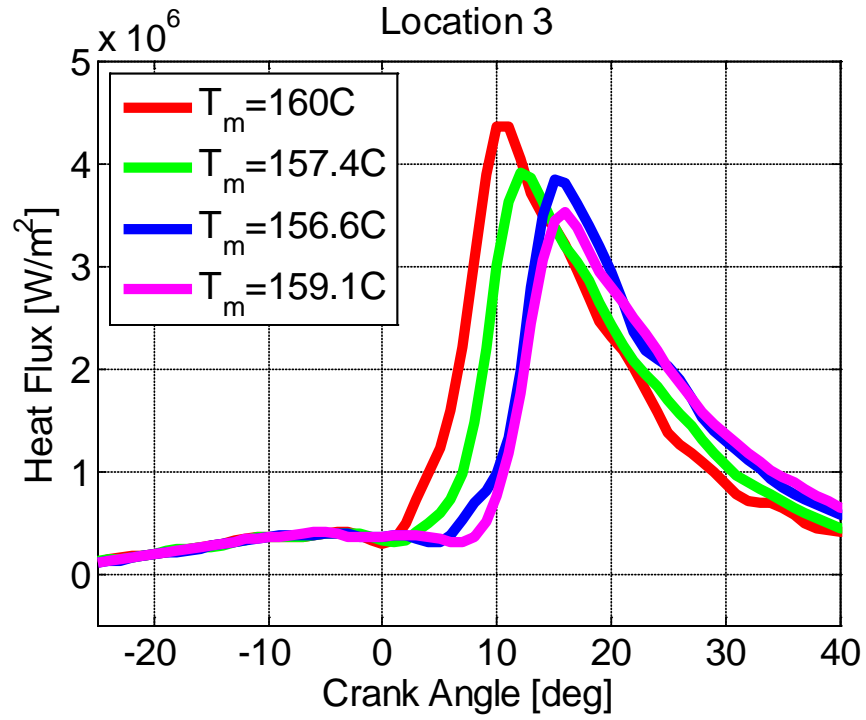
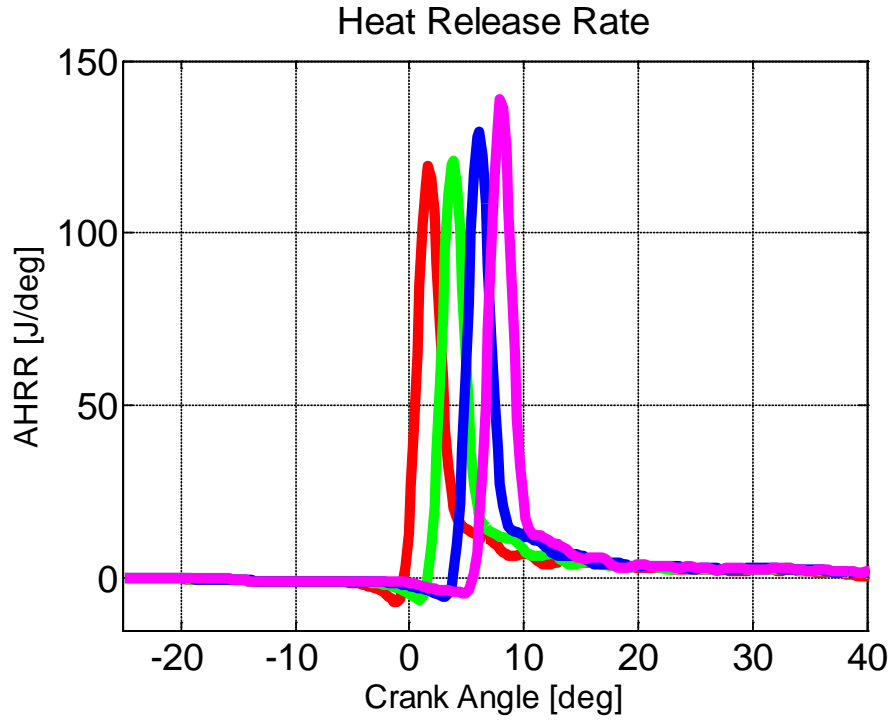

# HCCI CA50 Sweep

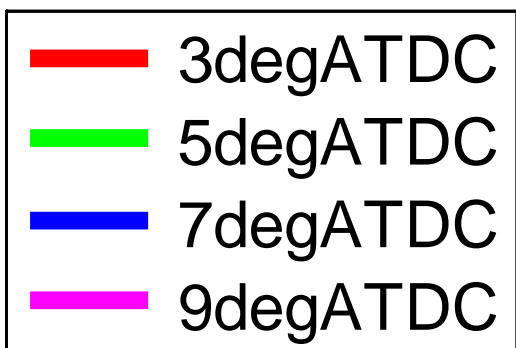

Fixed 5.7bar IMEPg

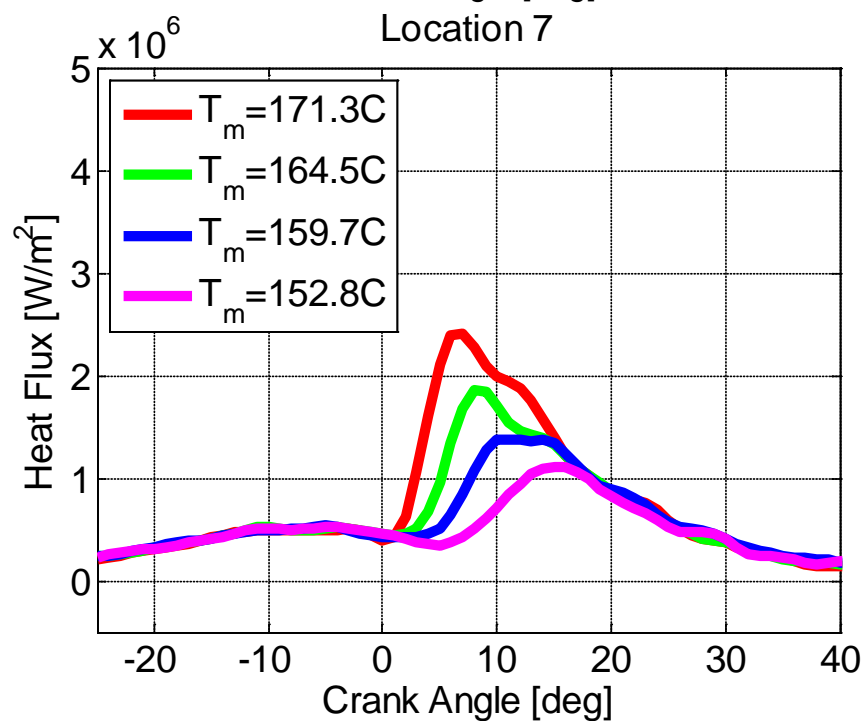
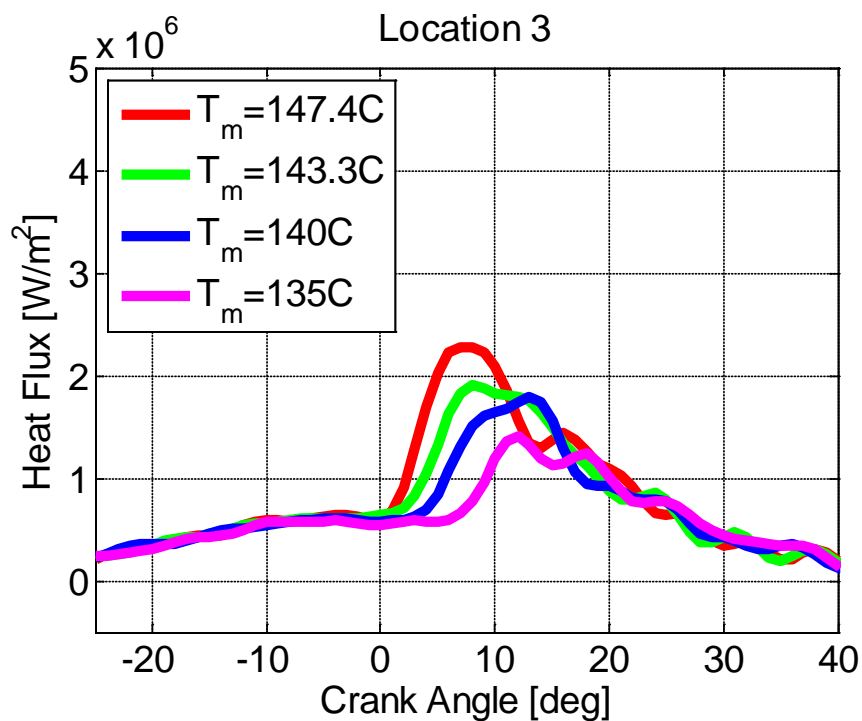
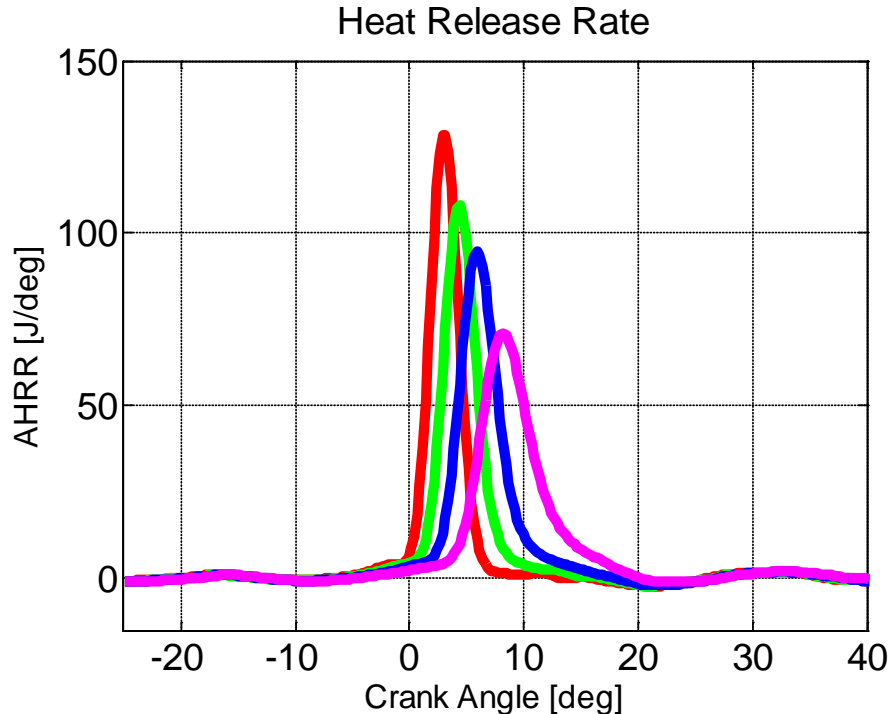

# RCCI CA50 Sweep

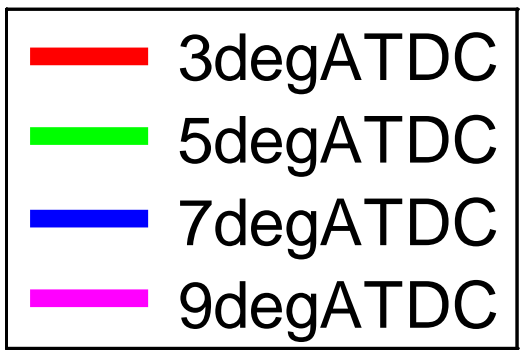

Fixed 5.7bar IMEPg

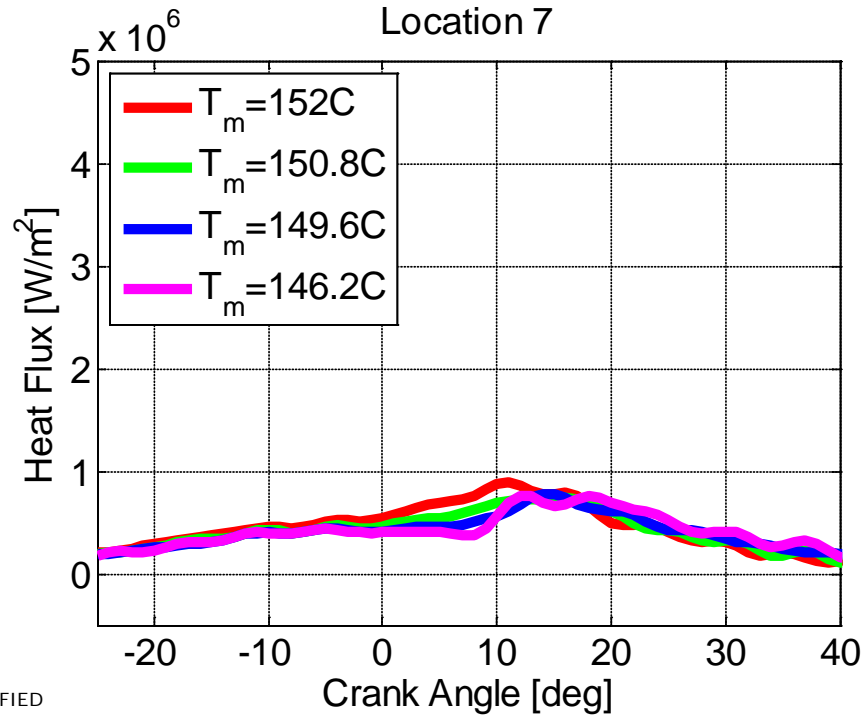
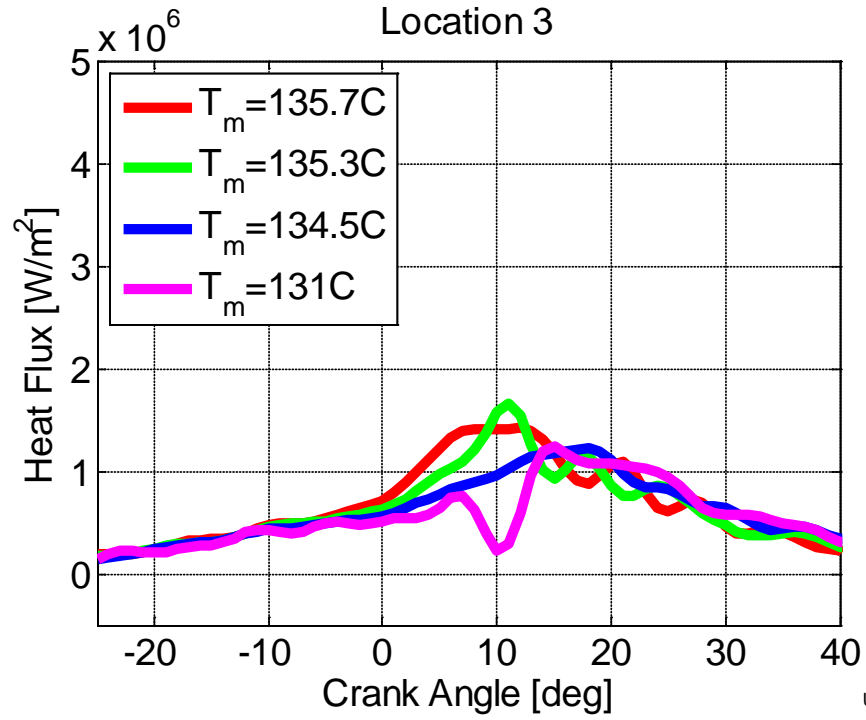
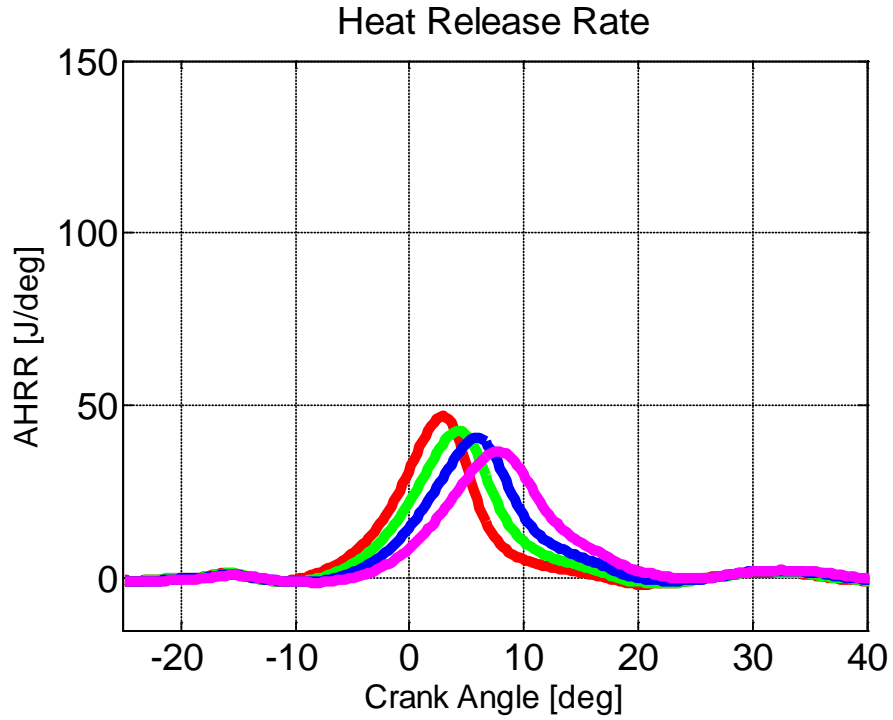



U.S. ARMY  
**RDECOM**  
TECHNOLOGY DRIVEN. WARFIGHTER FOCUSED.

# CA50 Sweep Summary



UNCLASSIFIED

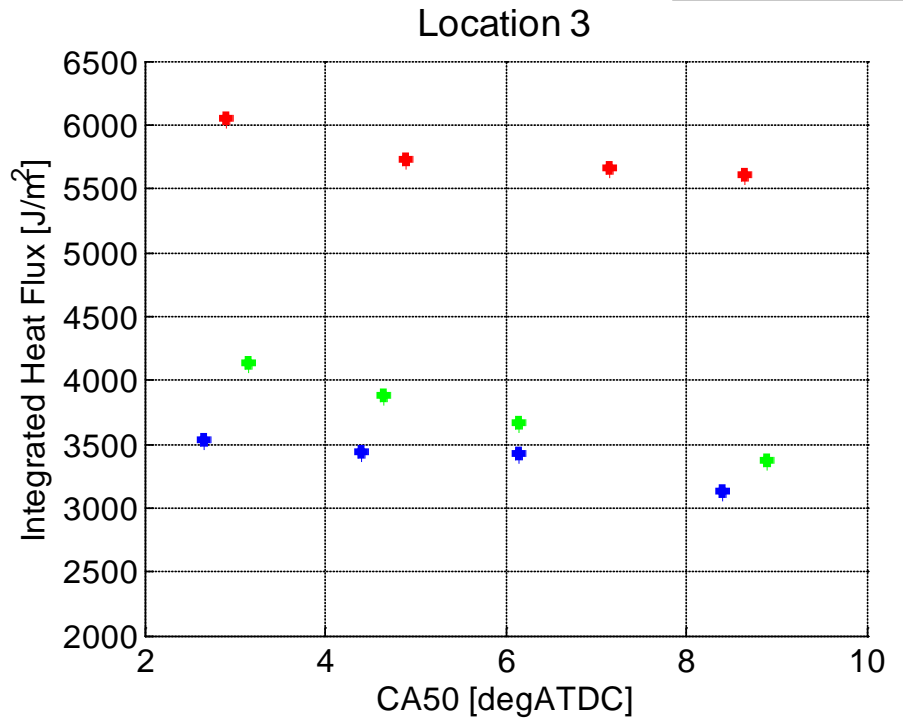
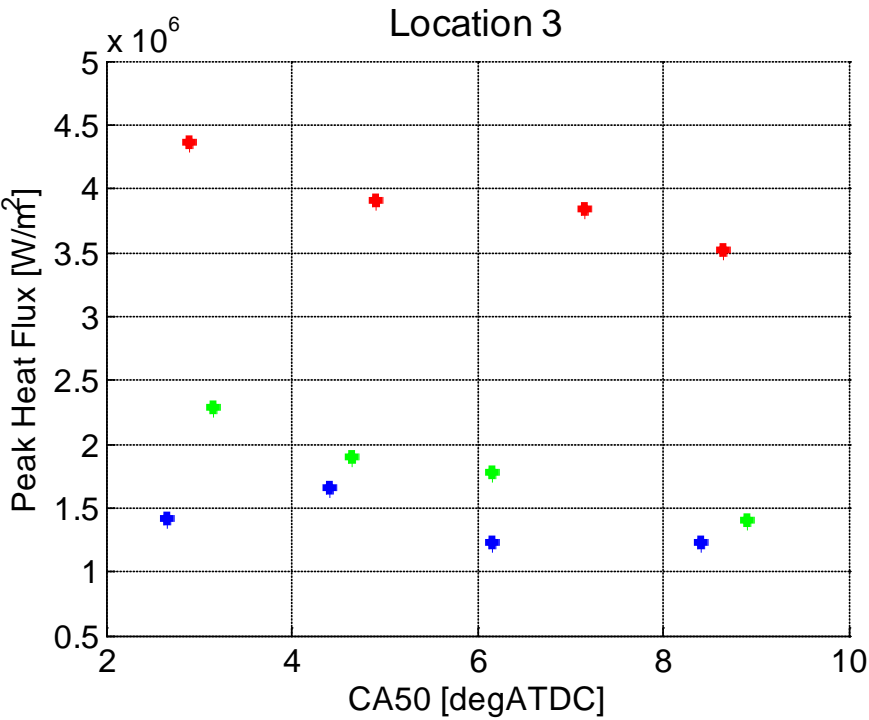
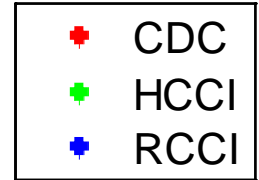

UNCLASSIFIED



U.S. ARMY  
**RDECOM**  
TECHNOLOGY DRIVEN. WARFIGHTER FOCUSED.

# CA50 Sweep Summary



UNCLASSIFIED

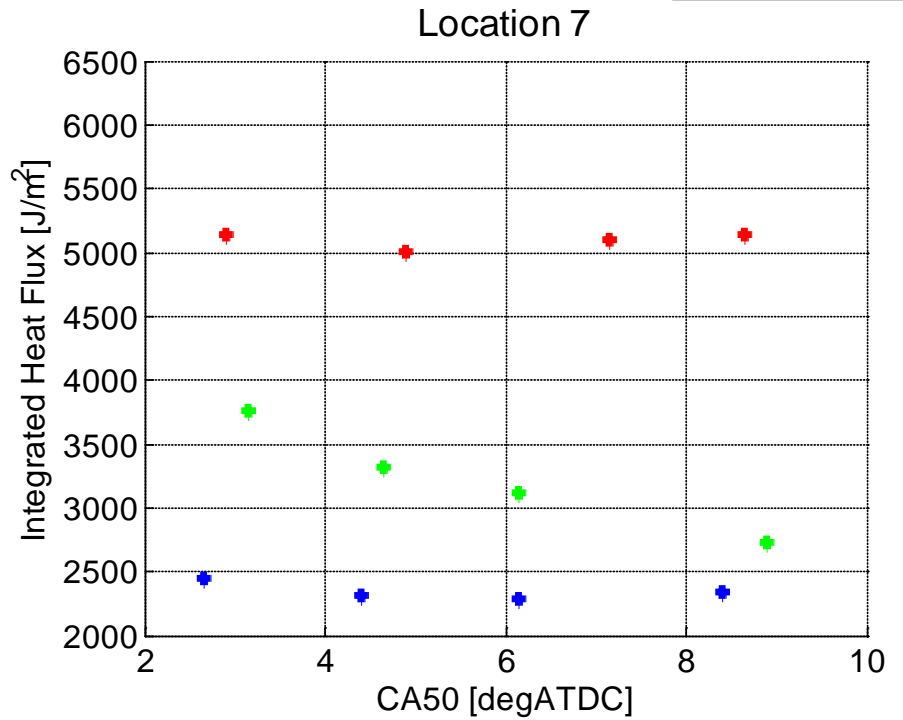
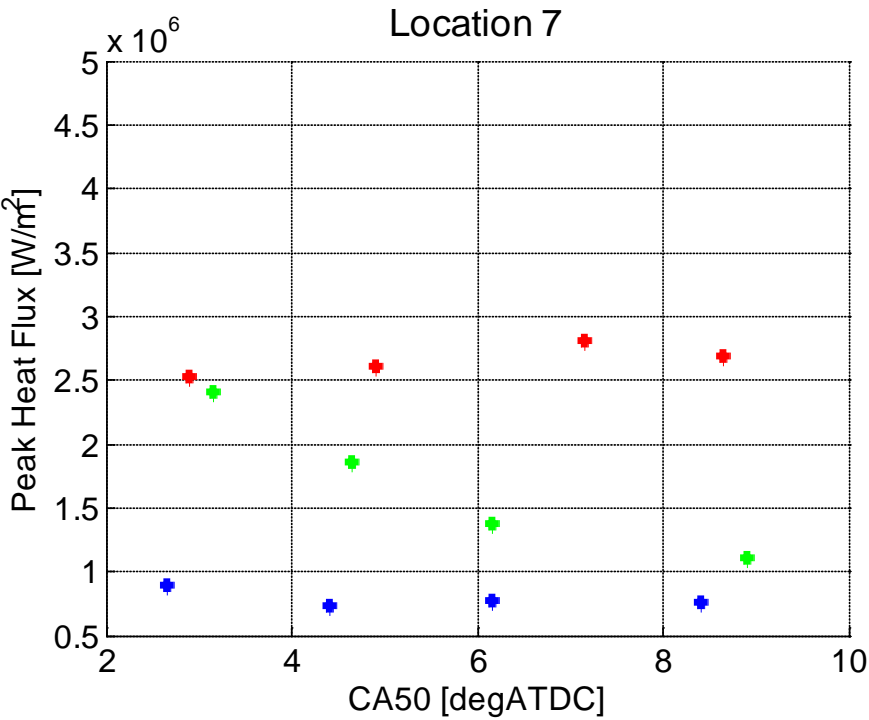
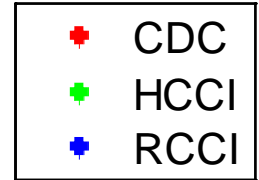

UNCLASSIFIED

# CDC Swirl Sweep

Fixed 5.7 bar IMEPg

Fixed 5 degATDC CA50

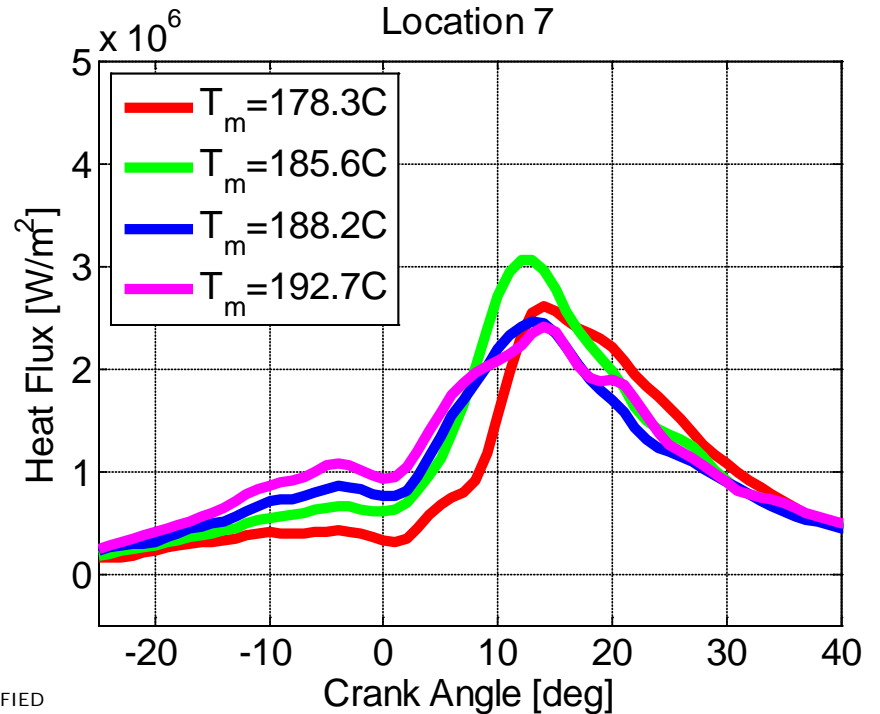
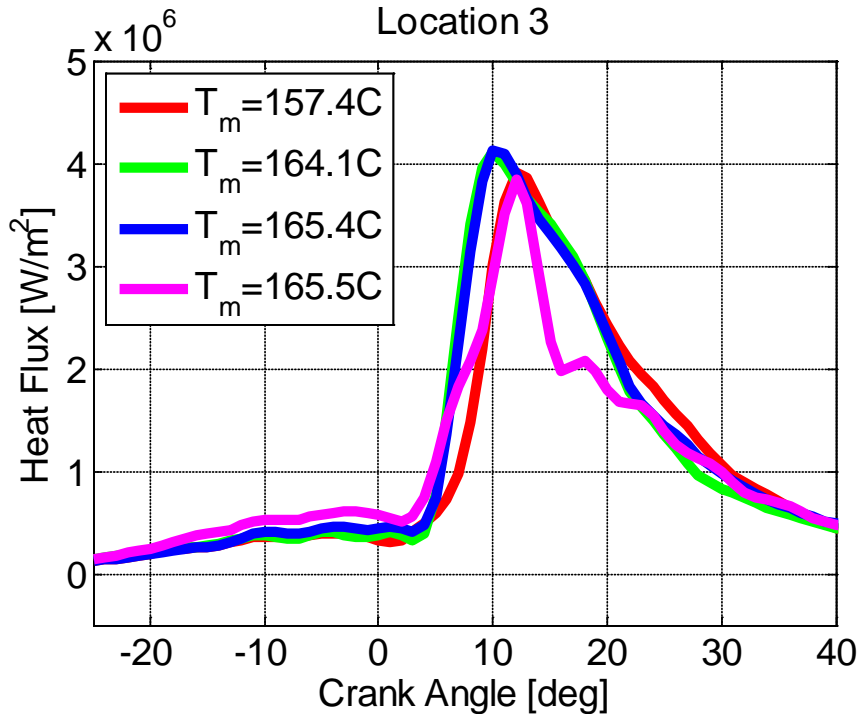
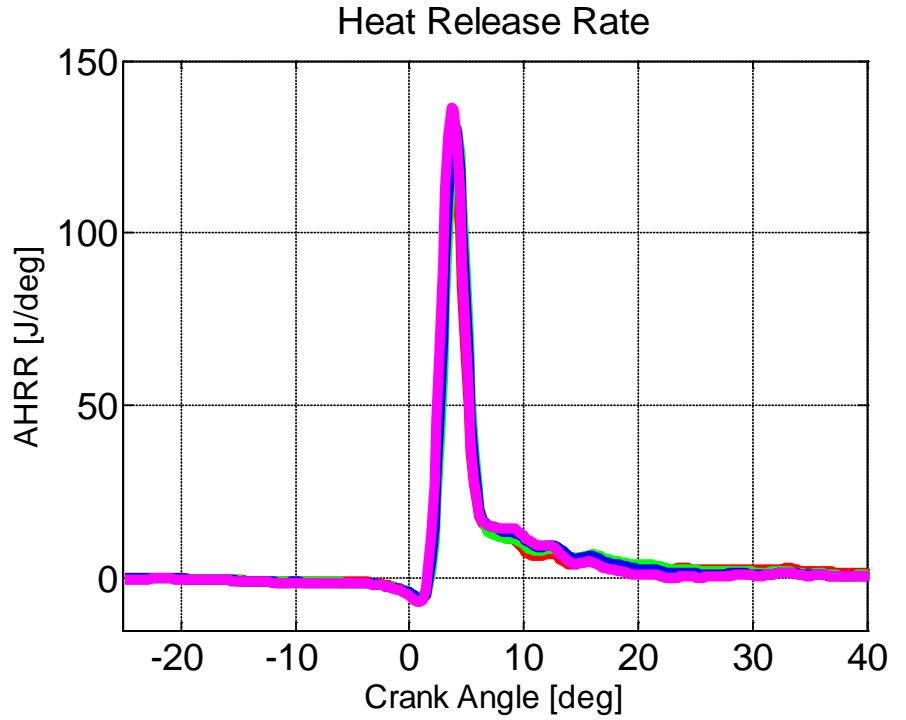

# HCCI Swirl Sweep

Fixed 5.7 bar IMEPg

Fixed 5 deg ATDC CA50

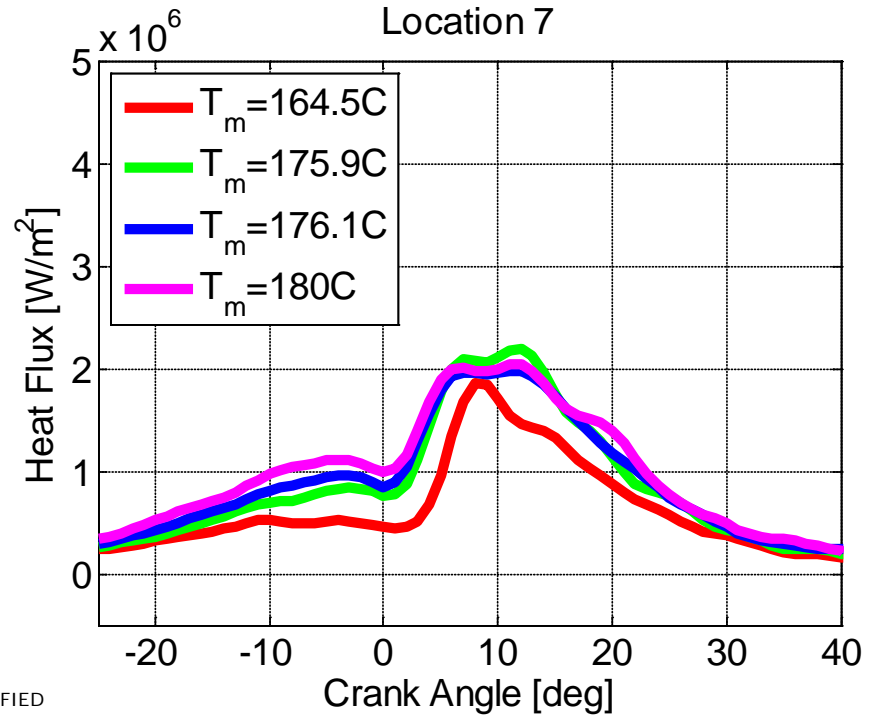
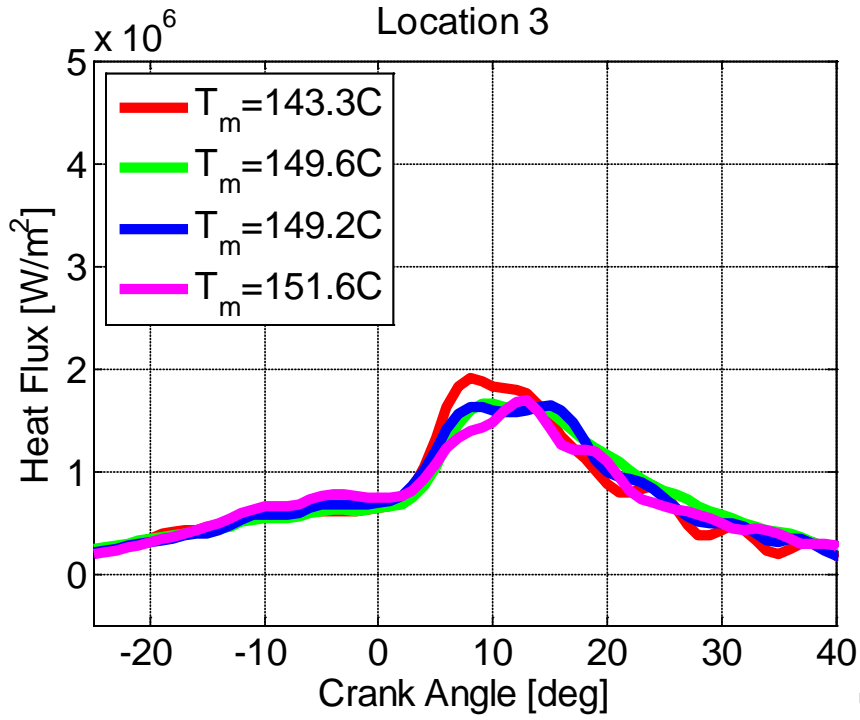
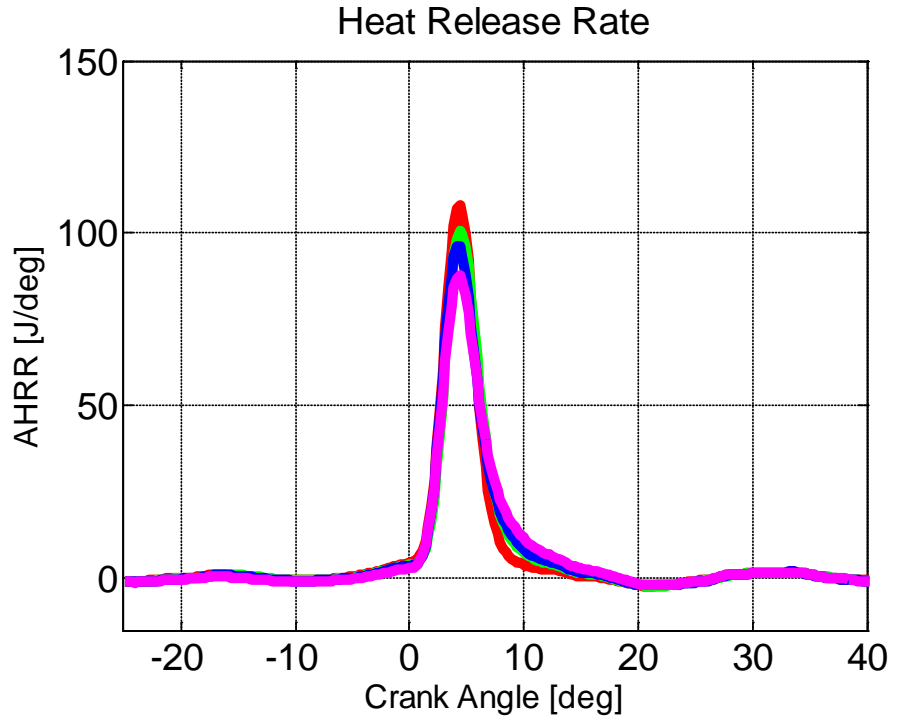

# RCCI Swirl Sweep

Fixed 5.7 bar IMEPg

Fixed 5 degATDC CA50

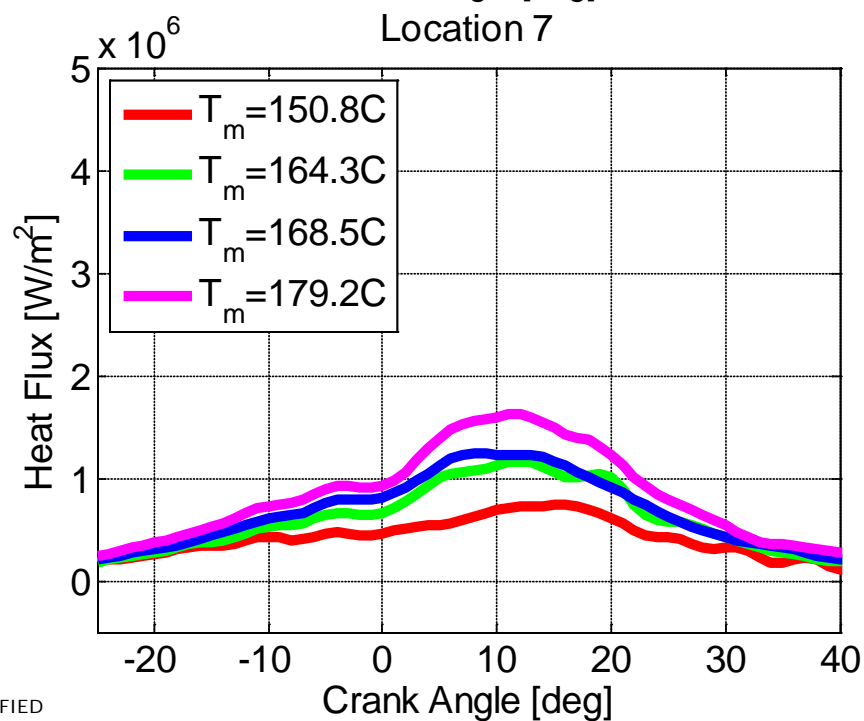
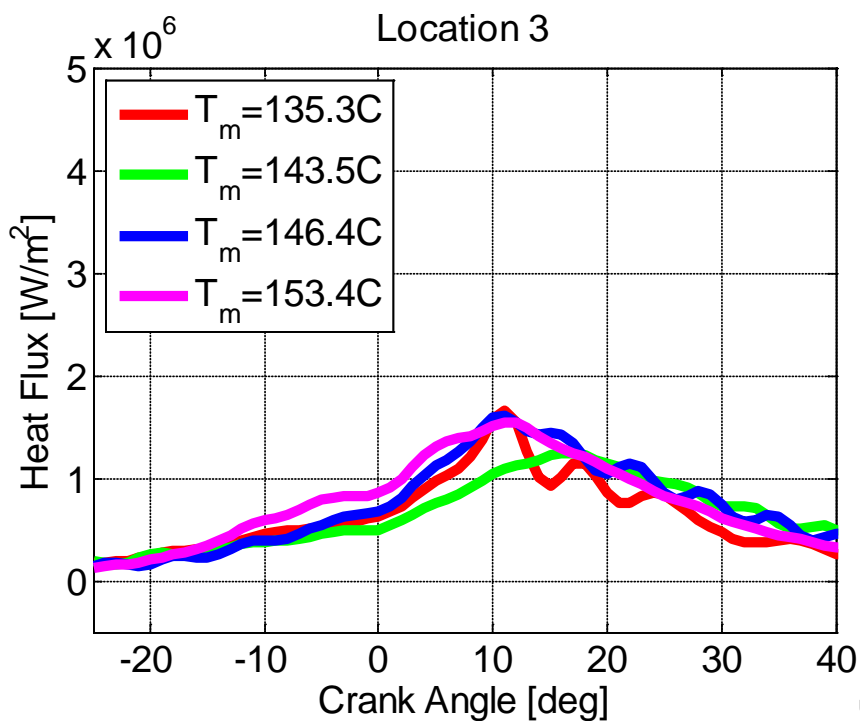
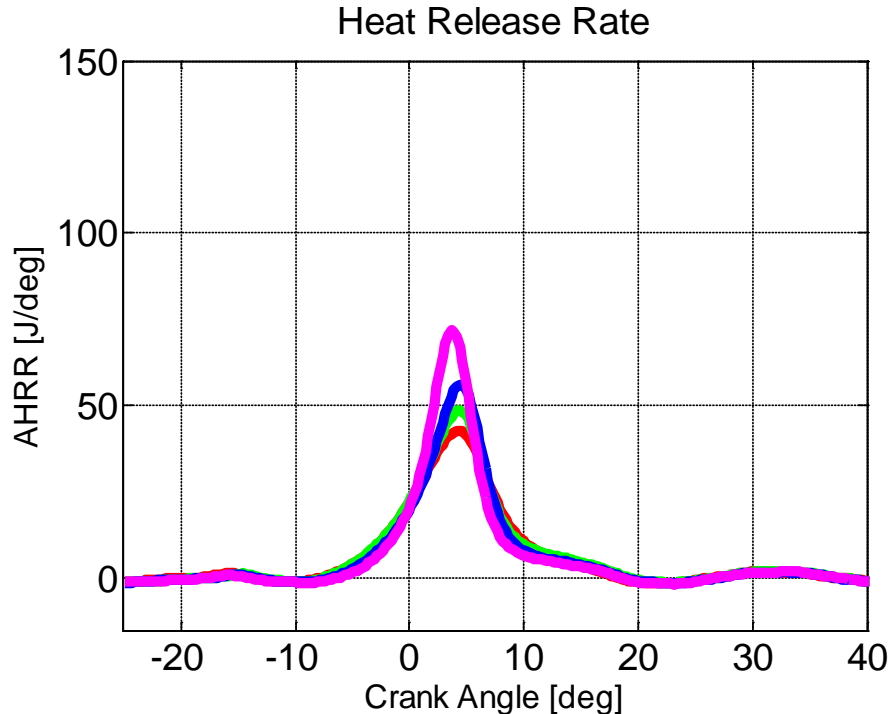
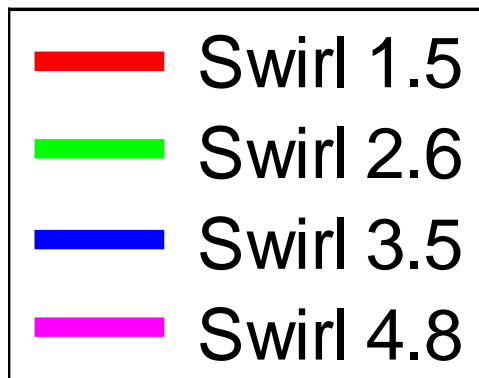



# Conclusions

UNCLASSIFIED



- RCCI and HCCI had a lower peak and closed-cycle integrated heat flux than CDC for all cases. The LTC strategies have lower in-cylinder temperatures than CDC, which is considered to be the main effect. Locally rich areas in CDC also lead to the formation of soot, which may also impact the heat flux; soot radiation is not expected to be present in LTC.
- HCCI peak heat flux was similar to RCCI except for cases when the combustion duration for HCCI was significantly shorter than for RCCI, causing a violent combustion event with a high PPRR. The high PPRR events may have an effect on the piston boundary layer, causing HCCI heat flux to more closely resemble CDC.
- An increase in swirl caused an increase in peak and closed-cycle integrated heat flux for RCCI and HCCI, but the trend was not as apparent for CDC. CDC is a stochastic process with directional spray plumes. Swirl may redirect the location of the plumes onto or away from the thermocouples, affecting the measured heat flux at each location.
- As CA50 is advanced the peak and closed-cycle integrated heat flux increases for HCCI. RCCI and HCCI have similar peak heat flux for retarded CA50 but as CA50 is advanced the peak heat flux increases for HCCI. The peak HCCI heat flux measured in the squish region is more strongly affected and begins to more closely resemble CDC.

UNCLASSIFIED



UNCLASSIFIED

# Thank You!

# Questions?

**Disclaimer:**

As the authors are not Government employees, this document was only reviewed for export controls, and improper Army association or emblem usage considerations. All other legal considerations are the responsibility of the author and his/her/their employers.

UNCLASSIFIED



# References

UNCLASSIFIED



- Rosner, Bernard (May 1983), Percentage Points for a Generalized ESD Many-Outlier Procedure, *Technometrics*, 25(2), pp. 165-172.
- IR Telemetry, <http://www.irtelemetry.com>, last checked 4/19/2012
- MEDTHERM CORP, Coaxial Surface Thermocouple Probes, Bulletin 500, 2006.

UNCLASSIFIED



UNCLASSIFIED

# Backup Slides

UNCLASSIFIED

- J-type thermocouple
  - Outer tube: Iron
  - Wire: Constantan
  - Temperature Range: -270-400°C
- Plated with Chromium
  - ~1μs time constant
- Cold-weld sliver
  - ~10μs time constant
  - Contour fit
- Electrical insulation wrapped around outer most element (tri-axial)
- Thermocouples manufactured and installed by MEDTHERM

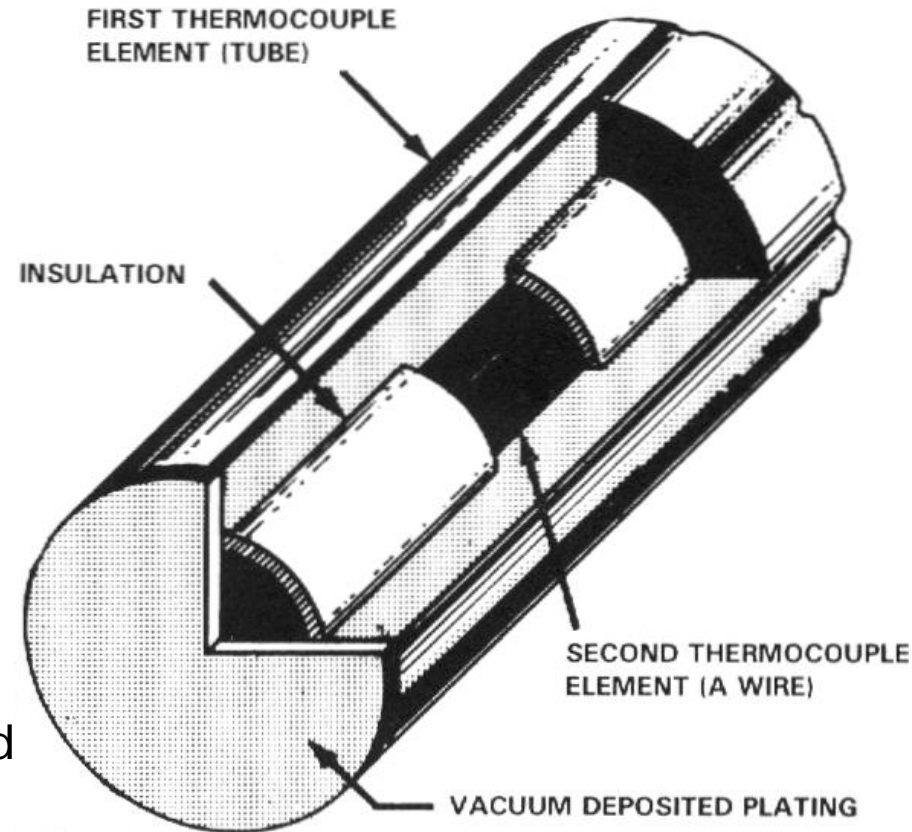

(MEDTHERM CORP, Bulletin 500)



U.S. ARMY  
**RDECOM**  
TECHNOLOGY DRIVEN. WARFIGHTER FOCUSED.

# Telemetry System



UNCLASSIFIED

- 10 kHz advertised bandwidth
- 8 channels (7 thermocouples + 1 marker)
- Multiplex configured at 0.50 seconds per channel
- Data recorded for 120 seconds
- Higher engine speeds yield more engine cycles

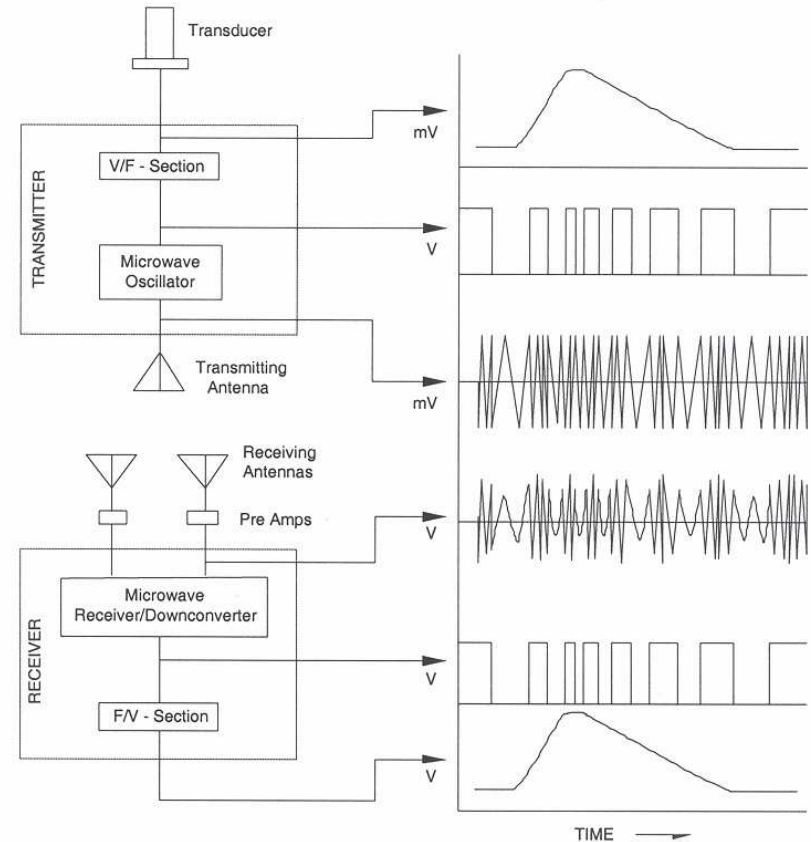

([www.irtelemetrics.com](http://www.irtelemetrics.com))

UNCLASSIFIED



U.S. ARMY  
**RDECOM**  
TECHNOLOGY DRIVEN. WARFIGHTER FOCUSED.

# Spray Location



UNCLASSIFIED

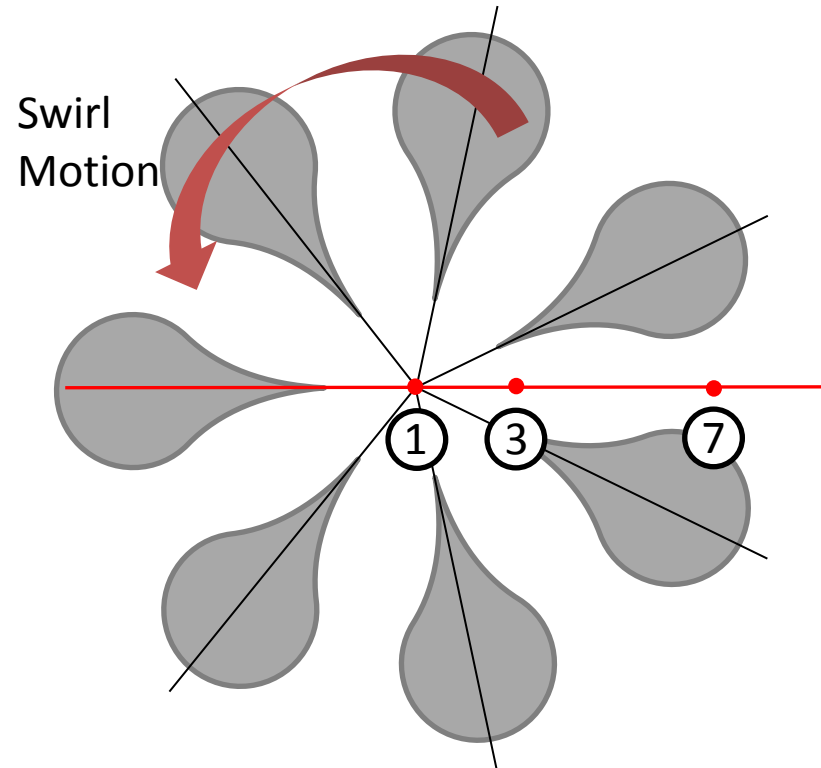

UNCLASSIFIED



# Injection Timings



UNCLASSIFIED

		CDC			RCCI		
		Injection Timing	Injection Duration	Injection Pressure	Injection Timing	Injection Duration	Injection Pressure
Combustion Phasing Effect	3degATDC	-10	0.531	1000	-56 / -36	0.296 / 0.261	500
	5degATDC	-8	0.53	1000	-59 / -39	0.82 / 0.256	500
	7degATDC	-6	0.532	1000	-63 / -43	0.565 / 0.252	500
	9degATDC	-4.5	0.534	1000	-65 / -45	0.255 / 0.250	500
Swirl Effect	1.5 Swirl	-8	0.53	1000	-59 / -39	0.281 / 0.256	500
	2.6 Swirl	-8	0.531	1000	-58 / -38	0.270 / 0.266	500
	3.5 Swirl	-8	0.53	1000	-59 / -39	0.265 / 0.266	500
	4.8 Swirl	-8	0.53	1000	-59 / -39	0.265 / 0.266	500
Combustion Strategy Effect	Mode 1	-26 / -6	.025 / 0.453	1000	-44	0.286	500
	Mode 2	-8	0.53	1000	-59 / -39	0.810 / 0.256	500
	Mode 3	-11	0.531	1000	-57 / -37	0.286 / 0.261	500
	Mode 4	-10	0.607	1000	-60 / -40	0.278 / 0.250	500

\*Note if two values are listed a dual injection stagey was used

UNCLASSIFIED