

# QwikSeal™

*an emerging alternative to conventional  
wet fastener installation*

Gary Schmidt

SERDP/ESTCP Workshop

Tempe, AZ

28 Feb 08

# Report Documentation Page

Form Approved  
OMB No. 0704-0188

Public reporting burden for the collection of information is estimated to average 1 hour per response, including the time for reviewing instructions, searching existing data sources, gathering and maintaining the data needed, and completing and reviewing the collection of information. Send comments regarding this burden estimate or any other aspect of this collection of information, including suggestions for reducing this burden, to Washington Headquarters Services, Directorate for Information Operations and Reports, 1215 Jefferson Davis Highway, Suite 1204, Arlington VA 22202-4302. Respondents should be aware that notwithstanding any other provision of law, no person shall be subject to a penalty for failing to comply with a collection of information if it does not display a currently valid OMB control number.

1. REPORT DATE <b>28 FEB 2008</b>		2. REPORT TYPE		3. DATES COVERED <b>00-00-2008 to 00-00-2008</b>	
4. TITLE AND SUBTITLE <b>QwikSeal an emerging alternative to conventional wet fastener installation</b>				5a. CONTRACT NUMBER	
				5b. GRANT NUMBER	
				5c. PROGRAM ELEMENT NUMBER	
6. AUTHOR(S)				5d. PROJECT NUMBER	
				5e. TASK NUMBER	
				5f. WORK UNIT NUMBER	
7. PERFORMING ORGANIZATION NAME(S) AND ADDRESS(ES) <b>Systems and Materials Research Corporation,1300 West Koenig Lane, Suite 230,Austin,TX,78724</b>				8. PERFORMING ORGANIZATION REPORT NUMBER	
9. SPONSORING/MONITORING AGENCY NAME(S) AND ADDRESS(ES)				10. SPONSOR/MONITOR'S ACRONYM(S)	
				11. SPONSOR/MONITOR'S REPORT NUMBER(S)	
12. DISTRIBUTION/AVAILABILITY STATEMENT <b>Approved for public release; distribution unlimited</b>					
13. SUPPLEMENTARY NOTES <b>Surface Finishing and Repair Issues for Sustaining New Military Aircraft Workshop, February 26-28, 2008, Tempe, AZ. Sponsored by SERDP/ESTCP.</b>					
14. ABSTRACT					
15. SUBJECT TERMS					
16. SECURITY CLASSIFICATION OF:			17. LIMITATION OF ABSTRACT <b>Same as Report (SAR)</b>	18. NUMBER OF PAGES <b>14</b>	19a. NAME OF RESPONSIBLE PERSON
a. REPORT <b>unclassified</b>	b. ABSTRACT <b>unclassified</b>	c. THIS PAGE <b>unclassified</b>			

# In the Olden Days . . .

They actually mixed a Semkit or thawed a batch of pre-mixed frozen sealant, then manually applied it to individual fasteners.

Wet fastener installation was a painstaking, touch-labor intensive, incredibly messy process.

# In the Olden Days . . .

Sealant got on everything and even gummed up the tooling. The artisans hated just about every aspect of the wet installation process, from mixing to hazmat disposal, and every step in between.

# In the Olden Days . . .

And waste – there was plenty of it.

Any sealant that didn't get used up before its pot life expired got thrown away.



These are still the Olden Days.

*But help is on the way.*

# QwikSeal Pre-Sealed Fastening Technology

- Genesis
  - NAVAIR SBIR (TPOCs Jim Muller, Fred Lancaster)
  - Phase II just completed
- Objective

Develop pre-coated, self-sealing fastener technology

  - *No change to fastener*
  - *No change to hole size*
  - No change to tooling
  - Applicable to *all fastener types and interference conditions*





# Sealant Application by Electronic Fluid Dispensing

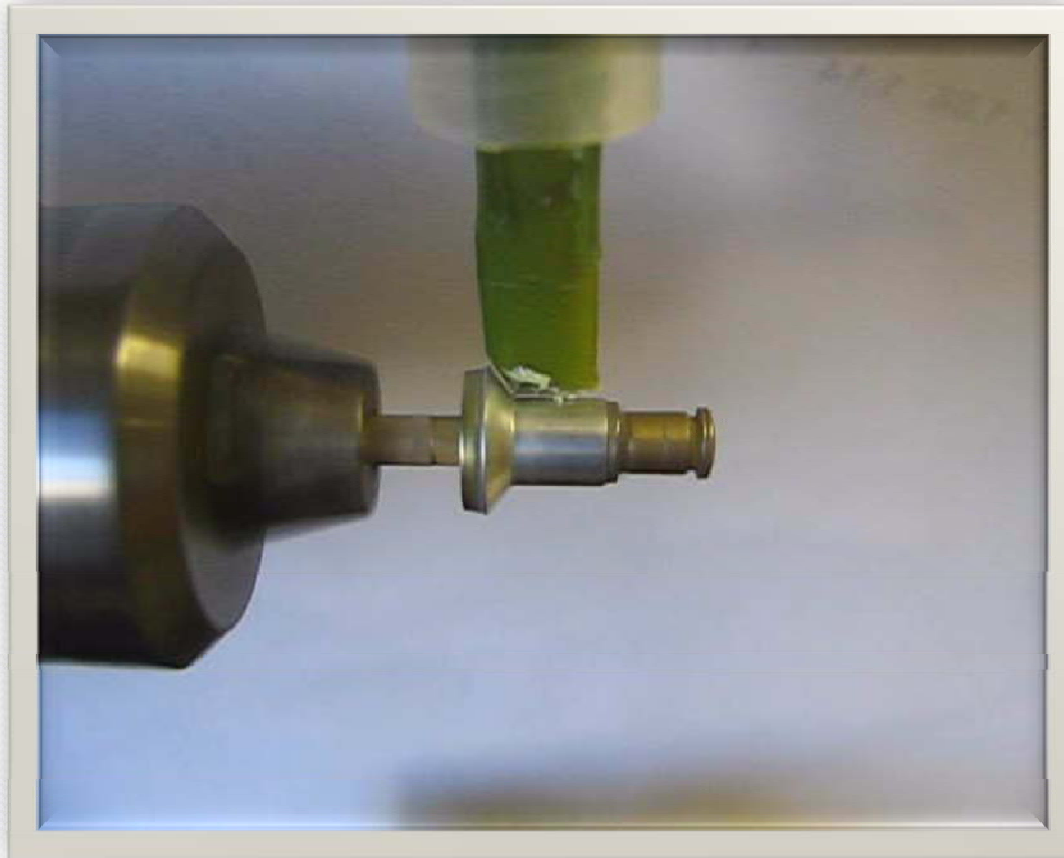

*Metered dispense cycle ensures consistent quality, reduced hazmat footprint*

# QwikSeal Automation Design

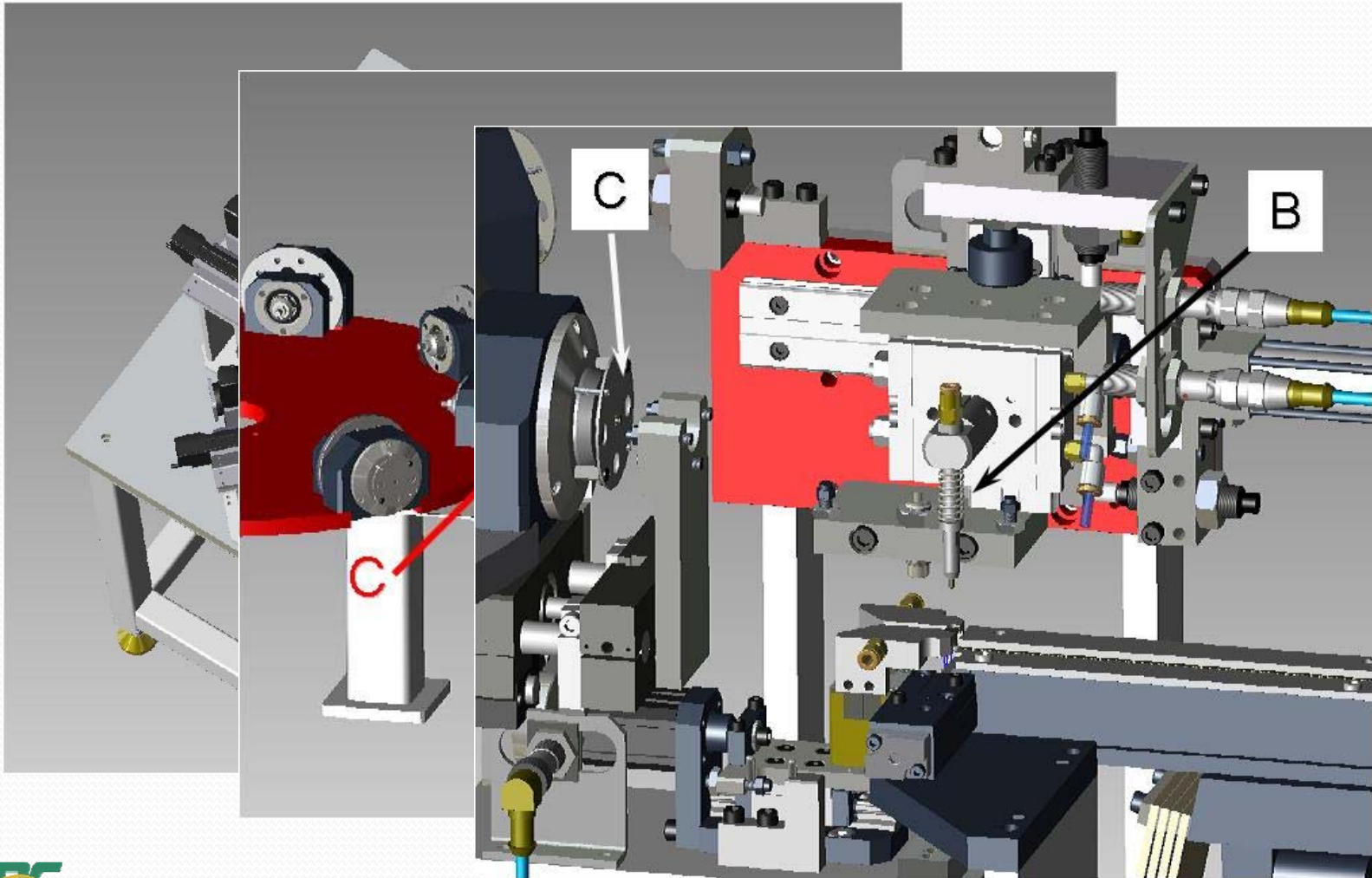

# Other Potential Applications

- Nutplates
- Channels
- Donuts
- Faying surfaces

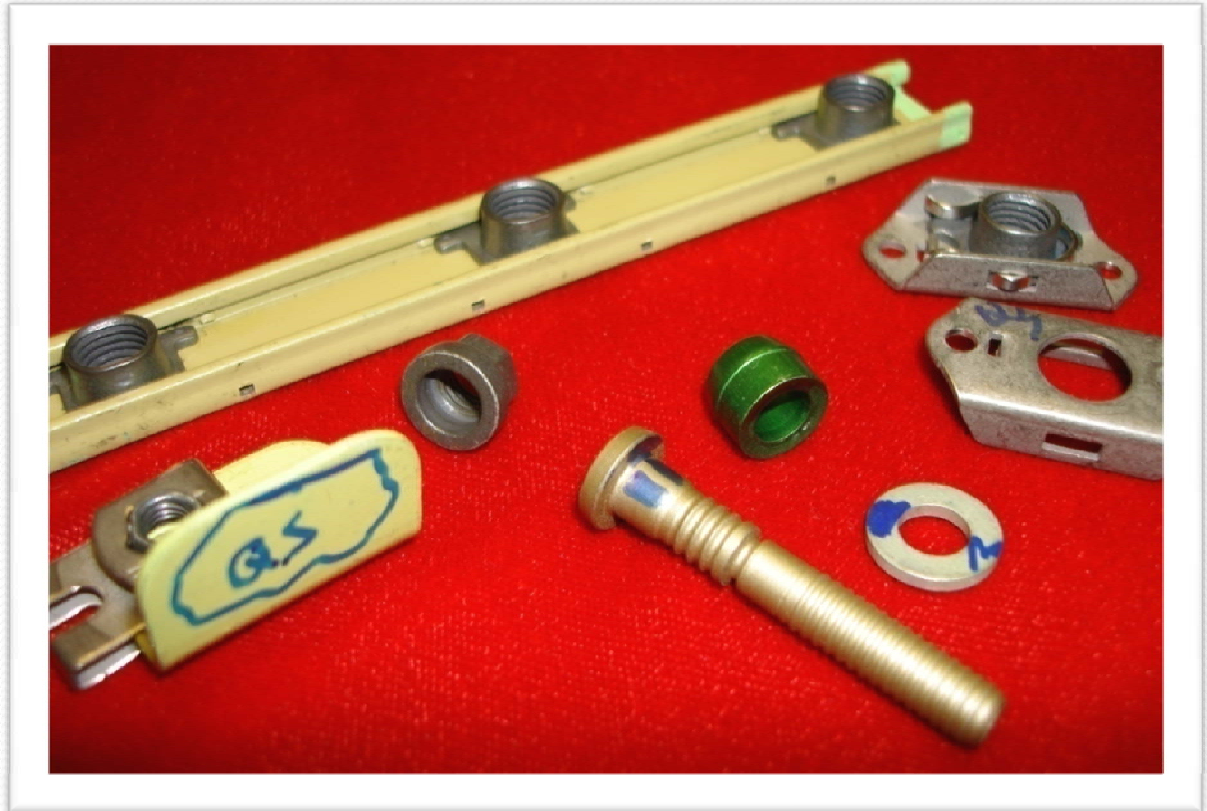

# QwikSeal Status

- Phase II completed end of Dec – TRL 4
  - Continuing development limited pending add'l funding
- Automation
  - QwikSeal machine design – 85% complete
    - 1 million fastener/month/machine initial rate goal
- **Joint development agreement signed with PRC-DeSoto/PPG Aerospace**
  - PPG has assumed sealant formulation optimization
  - SMRC continues UV cure size coat optimization on IR&D
- **Lockheed Martin F-35 endorsement pending**
  - Adoption contingent on qual and favorable cost-benefit analysis

# Steps to Transitioning QwikSeal

- Complete sealant and size coat optimization
- Establish appropriate qualification test plan
  - Coordinated with AFRL/NAVAIR, primes
  - Including corrosion, puffer box, etc.
- Perform cost-benefit analysis (LMA)
- Build, troubleshoot, tune QwikSeal application testbed
  - Base at PRC-DeSoto ASC-Los Angeles
- Complete qualification testing

# QwikSeal to the Marketplace

*SMRC and PRC-DeSoto International/PPG Aerospace have entered into an agreement whereby PPG will offer JIT QwikSeal sales/services to OEMs and depots through its global network of Application Support Centers (ASCs).*



*Thank you for your attention!*

**Questions?**

*For more info*

Gary Schmidt  
Systems and Materials Research Corporation (SMRC)  
1300 West Koenig Lane, Suite 230  
Austin, Texas 78731  
(512) 535-7791  
[garyschmidt@systemsandmaterials.com](mailto:garyschmidt@systemsandmaterials.com)