

Award Number: **W81XWH-11-1-0130**

TITLE: **Eliminating Late Recurrence to Eradicate Breast Cancer**

PRINCIPAL INVESTIGATOR: **Jayanta Debnath**

CONTRACTING ORGANIZATION: **University of California, San Francisco**
San Francisco, CA 94103-4249

REPORT DATE: **September 2013**

TYPE OF REPORT: **Annual**

PREPARED FOR: U.S. Army Medical Research and Materiel Command
Fort Detrick, Maryland 21702-5012

DISTRIBUTION STATEMENT: Approved for Public Release;
Distribution Unlimited

The views, opinions and/or findings contained in this report are those of the author(s) and should not be construed as an official Department of the Army position, policy or decision unless so designated by other documentation.

REPORT DOCUMENTATION PAGE

Form Approved
OMB No. 0704-0188

Public reporting burden for this collection of information is estimated to average 1 hour per response, including the time for reviewing instructions, searching existing data sources, gathering and maintaining the data needed, and completing and reviewing this collection of information. Send comments regarding this burden estimate or any other aspect of this collection of information, including suggestions for reducing this burden to Department of Defense, Washington Headquarters Services, Directorate for Information Operations and Reports (0704-0188), 1215 Jefferson Davis Highway, Suite 1204, Arlington, VA 22202-4302. Respondents should be aware that notwithstanding any other provision of law, no person shall be subject to any penalty for failing to comply with a collection of information if it does not display a currently valid OMB control number. **PLEASE DO NOT RETURN YOUR FORM TO THE ABOVE ADDRESS.**

1. REPORT DATE September-2013		2. REPORT TYPE Annual		3. DATES COVERED 1 September 2012-31 August 2013	
4. TITLE AND SUBTITLE Eliminating Late Recurrence to Eradicate Breast Cancer				5a. CONTRACT NUMBER	
				5b. GRANT NUMBER W81XWH-11-1-0130	
				5c. PROGRAM ELEMENT NUMBER	
6. AUTHOR(S) Jayanta Debnath, M.D. E-Mail: Jayanta.debnath@ucsf.edu				5d. PROJECT NUMBER	
				5e. TASK NUMBER	
				5f. WORK UNIT NUMBER	
7. PERFORMING ORGANIZATION NAME(S) AND ADDRESS(ES) University of California San Francisco 1855 Folsom St, Ste 425 San Francisco, CA 94103-4249				8. PERFORMING ORGANIZATION REPORT NUMBER	
9. SPONSORING / MONITORING AGENCY NAME(S) AND ADDRESS(ES) U.S. Army Medical Research and Materiel Command Fort Detrick, Maryland 21702-5012				10. SPONSOR/MONITOR'S ACRONYM(S)	
				11. SPONSOR/MONITOR'S REPORT NUMBER(S)	
12. DISTRIBUTION / AVAILABILITY STATEMENT Approved for Public Release; Distribution Unlimited					
13. SUPPLEMENTARY NOTES					
14. ABSTRACT Breast cancer patients exhibit high rates of late recurrent metastatic disease, which arise from tumor cells that lay dormant for extended periods before they reawaken and develop into lethal metastases. We seek to delineate whether autophagy impacts the survival of dormant tumor cells, or alternatively, influences their ability to exit from dormancy and produce overt metastatic disease. We have utilized a three-dimensional culture models as well as generated an in vivo mouse transgenic model to assay cellular quiescence and tumor dormancy in breast cancer. To date, our studies have uncovered two opposing, context-dependent functions for autophagy that impact late recurrent metastatic progression. On the one hand, in breast tumors driven by the PI3K pathway, autophagy restricts proliferation and maintains a quiescent state. On the other, in tumors with hyper-activation of the Ras/MAPK pathway, autophagy promotes invasive behavior and alters epithelial differentiation and secretion. For our ongoing in vivo studies, we will place high priority on elaborating whether and how these two paradoxical functions for the autophagy pathway impact late disease progression in breast cancer. In fact, our in vivo studies over the past year indicate that autophagy inhibition promotes, rather than impedes the metastasis of polyoma middle T (PyMT) mammary cancers in vivo, which have unexpected implications for autophagy in late recurrent disease by modulating the activation of dormant tumor cells to produce overt metastatic disease. We will further corroborate this hypothesis in the upcoming years using the primary in vivo models developed through this project.					
15. SUBJECT TERMS breast cancer, mouse models, organotypic culture, autophagy, quiescence, dormancy					
16. SECURITY CLASSIFICATION OF:			17. LIMITATION OF ABSTRACT UU	18. NUMBER OF PAGES 90	19a. NAME OF RESPONSIBLE PERSON USAMRMC
a. REPORT U	b. ABSTRACT U	c. THIS PAGE U			19b. TELEPHONE NUMBER (include area code)

Table of Contents

	<u>Page</u>
Introduction.....	4
Body.....	4
Key Research Accomplishments.....	23
Reportable Outcomes.....	24
Conclusion.....	26
References.....	27
Appendices.....	28



I. INTRODUCTION:

Late recurrence continues to be a major barrier to eradicating breast cancer. These tumors develop after a lengthy period of dormancy, exhibit resistance to available treatments, and are commonly metastatic; as a result, late recurrence is a principal cause of lethality in breast cancer patients. Current evidence supports that such late recurrences in breast cancer likely arise from disseminated tumor cells that lie clinically dormant for extended periods of time [1]. These wayward breast cells either persist as solitary dormant cells, or form avascular micrometastases, which also remain dormant and clinically undetectable, presumably until they recruit appropriate micro-environmental factors to expand [1]. Nevertheless, to date, it remains largely unclear what biological processes govern the critical steps in late recurrent disease. These steps include: 1) the entry of breast cancer cells into dormancy, 2) the maintenance and survival of these cells during lengthy periods of quiescence, and ultimately, 3) their exit from dormancy to produce overt metastatic disease [2,3]. The overall goal of our research is to evaluate how changes in autophagy, a tightly-regulated lysosomal digestion process, impact one or more of these critical steps in the development of late recurrent breast cancer via the regulation of quiescent versus proliferative behavior exhibited by cancer cells. To address this issue, we have been taking several approaches in three-dimensional culture models as well as generating an in vivo mouse transgenic model to assay cellular quiescence and tumor dormancy in breast cancer.

During the year 1 of this award, our work in 3D culture models uncovered that autophagy inhibition, achieved either via genetic loss-of-function of ATGs or via anti-malarials, promoted the active proliferation of quiescent cells. These findings were published and had unexpected implications for autophagy in late recurrent disease by modulating the exit of dormant tumor cells from quiescent states to produce overt metastatic disease [4]. Based on this important data as well as other studies in year 1, we focused on the following goals and tasks during year 2 of the award: (1) Because our initial 3D studies were conducted in the context of oncogenic PI3K activation, we dissected how autophagy inhibition impacted the proliferative and invasive behavior of breast cancer cells harboring more aggressive oncogenic insults, namely oncogenic Ras/MAPK activation. (2) We began to assess the role of autophagy inhibition in macrometastatic outgrowth in the Polyoma middle T (PyMT) transgenic model in vivo in order to test the prediction that decreased autophagy promotes the exit of dormant tumor cells to produce overt metastatic disease. Importantly, since PyMT tumors are highly dependent on PI3K pathway activation, this model provided us with a unique opportunity to extend our 3D culture results to an in vivo system. (3) Continue to develop the compound transgenic mice result for our studies and begin pilot experiments to evaluate their utility as an in vivo breast cancer late recurrence model.

II. RESEARCH ACCOMPLISHMENTS BODY:

Task 1. Establish three-dimensional mammary epithelial cell culture and in vivo mouse model systems for late breast cancer recurrence.

a. Establish three-dimensional mammary epithelial organotypic cell culture model system cultured on basement membrane. (Months 1-12).

This sub-task was **completed** during year 1 and the findings were reported in the 2012 Annual Progress Report. Our studies of oncogenic-PI3K transformed breast cancer cells were published in *Oncogene* [4]; the full manuscript was included in the Appendix of the 2012 Annual Progress Report. Importantly, these data suggested that the inhibition of autophagy paradoxically promotes the active growth of quiescent cells, thus arguing against our originally proposed hypothesis. Since these studies were conducted using PI3K transformed cells, it was crucial to assess if these phenotypes were oncogene dependent or a general effect of autophagy inhibition. Thus, we began to test this alternative prediction using more aggressive 3D models in subtask 1b and using newly developed in vivo models in sub-tasks 2b-c. These follow-up experiments have been the major experimental priority during year 2 (Months 12-24) of the EOHS and are detailed below.

b. Quantify rates of proliferation and apoptosis in human breast cancer cell lines grown in three-dimensional epithelial organotypic cell culture (Months 1-24).

In year 1, we had assessed the proliferative and aggressive behavior of multiple breast cancer cell lines, reported in the 2012 Annual Progress Report. Those studies uncovered that the triple negative breast cancer cell lines we analyzed, MDA-MD-231 and Hs578 failed to exhibit quiescent behavior or cell death in the “on top” 3D culture assay that we had developed; instead, they were notable for invasive protrusions in the 3D matrix. Notably, both MDA-MD-231 and Hs578 cells harbor aberrations in the Ras pathway due to oncogenic mutations in K-Ras or H-Ras [5]. Because our first publication in *Oncogene* demonstrated that autophagy inhibition promoted aberrant Ras/MAPK activation secondary to p62 accumulation in PI3K transformed cells [4], we speculated that breast cancer cells with preexisting activation in the Ras/MAPK pathway would not exhibit enhanced proliferation upon autophagy inhibition in 3D culture. Rather, based on previous work from our lab and others, they would be more sensitive to autophagy inhibition [6-10]. Thus, in contrast to PI3K activation, we speculated that autophagy inhibition would prevent 3D aggressive behavior in breast cancer cells exhibiting Ras/MAPK pathway hyperactivation.

To precisely test this hypothesis, we utilized the MCF10A-based 3D model created in subtask 1a. Using MCF10A cells expressing oncogenic Ras (H-Ras^{V12}), we examined the effects of genetic autophagy inhibition in 3D culture. To inhibit autophagy in this experimental system we stably expressed unique short-hairpin RNAs (shRNA) against multiple autophagy genes (ATGs)—*atg7* (shATG7-1 and shATG7-2) or *atg12* (shATG12) in MCF10A cells stably expressing H-Ras^{V12}. Depletion of ATG7 or ATG12 decreased target protein levels, reduced basal and starvation (HBSS) induced autophagy, and increased protein levels of the autophagy substrate p62/SQSTM1 (Fig 1A-C). Importantly, stable knockdown of ATGs in H-Ras^{V12} cells did not affect Ras expression levels or activation associated phosphorylation of the major downstream effector ERK (Fig. 1D).

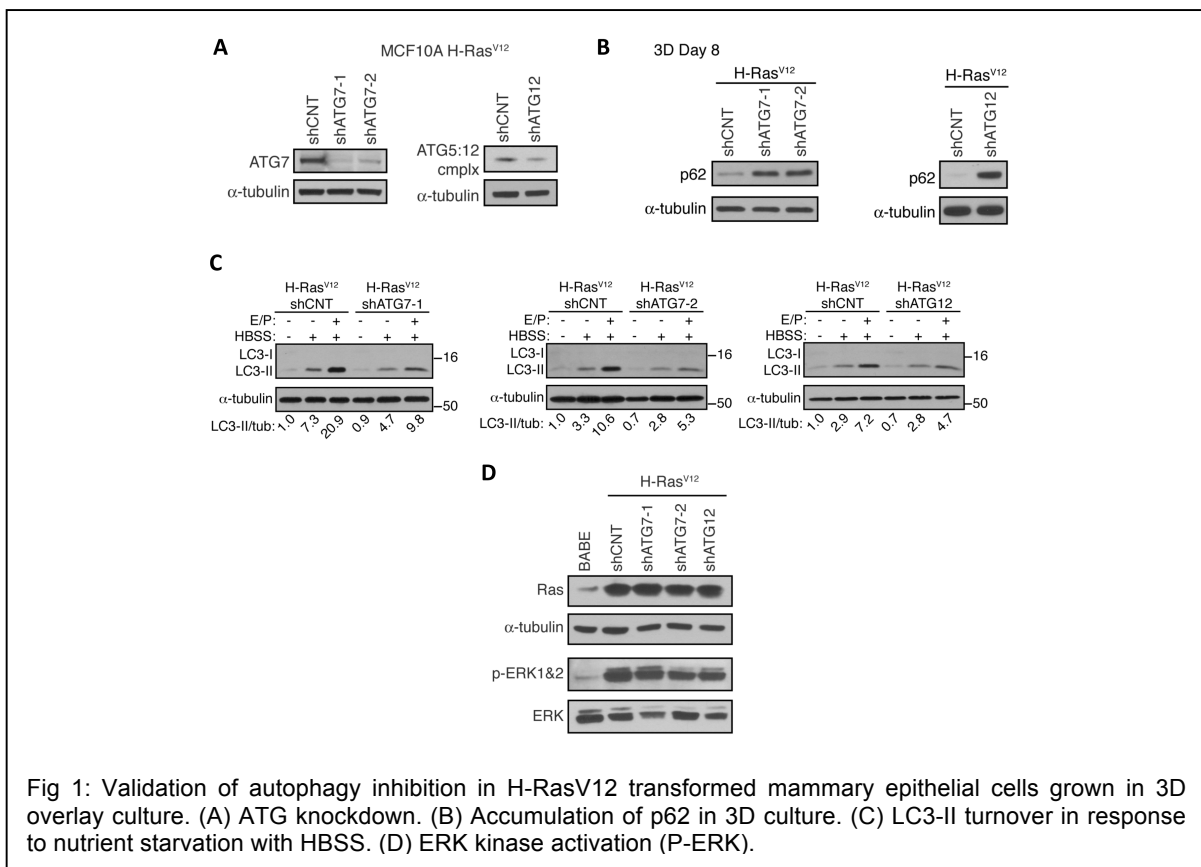

First, we scrutinized the effects of autophagy inhibition on cell death and proliferation in H-Ras^{V12} 3D cultures. To test whether autophagy deficiency impacted apoptosis in H-Ras^{V12} structures, we immunostained structures with an antibody against cleaved caspase-3. In contrast to the robust luminal apoptosis observed in control acini (BABE), only isolated cleaved caspase-3 positive cells were observed in H-Ras^{V12} shCNT structures, consistent with the ability of oncogenic Ras to promote cell survival in 3D culture (Fig 2A). Upon enumerating cleaved caspase-3 positive cells from these 3D cultures, we found that ATG knockdown did not significantly impact apoptosis in comparison to shCNT cultures (Fig. 2A). To assess whether autophagy inhibition potentially impacted non-apoptotic death processes, we also stained day 8 3D cultures with ethidium bromide (EtBr), an intravital dye that is incorporated into all dying cells. Whereas acini derived from non-transformed (BABE) cells displayed high levels of EtBr staining corresponding to luminal cell death (Fig. 2B), H-Ras^{V12} structures displayed only occasional EtBr cells scattered throughout the structures. Although ATG knockdown in H-Ras^{V12} cultures resulted in spherical structures that lacked invasive protrusions, we did not observe any increase in EtBr staining in these cultures (Fig. 2B). Thus, in contrast to normal and oncogenic PI3K MCF10A acinar morphogenesis, autophagy inhibition does not promote apoptosis in Ras-transformed 3D structures [4,11]. In parallel, we immunostained these 3D cultures with the proliferation marker, Ki67. As expected, low levels of Ki67 positive cells were observed in non-oncogenic control (BABE) structures (Fig 2C, left panels). However, both control and autophagy deficient H-Ras^{V12} structures

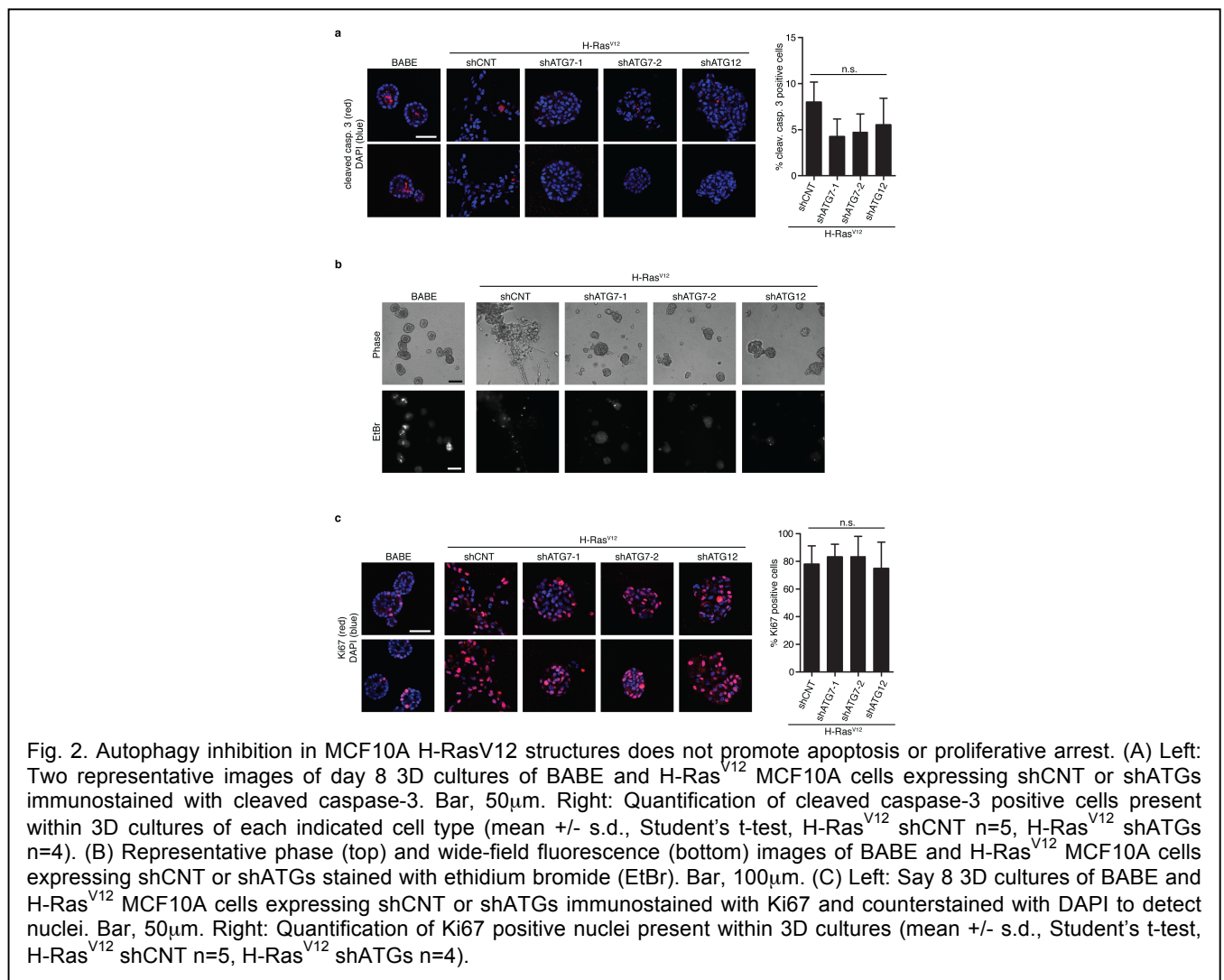

displayed high levels of Ki67 positive cells (Fig 2C). Overall, these results indicate that autophagy deficiency does not suppress the ability of activated Ras to inhibit apoptosis and sustain proliferation.

Although decreased autophagy did not impact proliferation and apoptosis, we discovered unexpected effects of autophagy modulation on 3D invasion. Similar to the triple negative breast cancer lines, Ras activation in 3D culture was notable for the formation of protrusions that invaded the surrounding extracellular matrix. Individual H-Ras^{V12} structures formed these invasive protrusions as early as 3-5 days, which rapidly migrated toward each other, ultimately producing disorganized networks of cells intermingled with large cell clusters after 8 days of growth in 3D culture (Fig. 3A and B, left columns). These invasive protrusions were profoundly attenuated in ATG deficient cells. Instead, H-Ras^{V12} shATG structures were spherical in morphology similar to non-transformed BABE controls.

This decrease in invasive protrusions following autophagy inhibition was also observed upon stable knockdown of an additional autophagy gene, *atg3* (shATG3), and upon treatment with chloroquine or bafilomycin A, two lysosomal inhibitors that block the late steps of autophagic proteolysis (Fig. 4). Because of these unexpected results we obtained regarding hyperactive Ras in breast cancer invasion, we chose to put effort in year 2 toward dissecting the mechanism underlying these phenotypes. As detailed below, these studies turned out to be highly informative from a mechanistic standpoint.

The disruption of basement membrane integrity is a hallmark of breast carcinoma invasion *in vivo* [12]. To corroborate whether the protrusions we observed in H-Ras^{V12}-transformed 3D cultures represented invasive behavior, we first evaluated basement membrane integrity by examining the expression and localization of the

basement membrane protein laminin 5 in H-Ras^{V12}-derived acini. Consistent with previous reports, control non-transformed MCF10A acini (BABE) displayed polarized deposition of laminin 5 onto the basal surface (Fig. 5A, left panels) [13]. In contrast, the expression of H-Ras^{V12} resulted in cytosolic accumulation of laminin 5, with no evidence of polarized deposition at the cell-ECM interface. Notably,

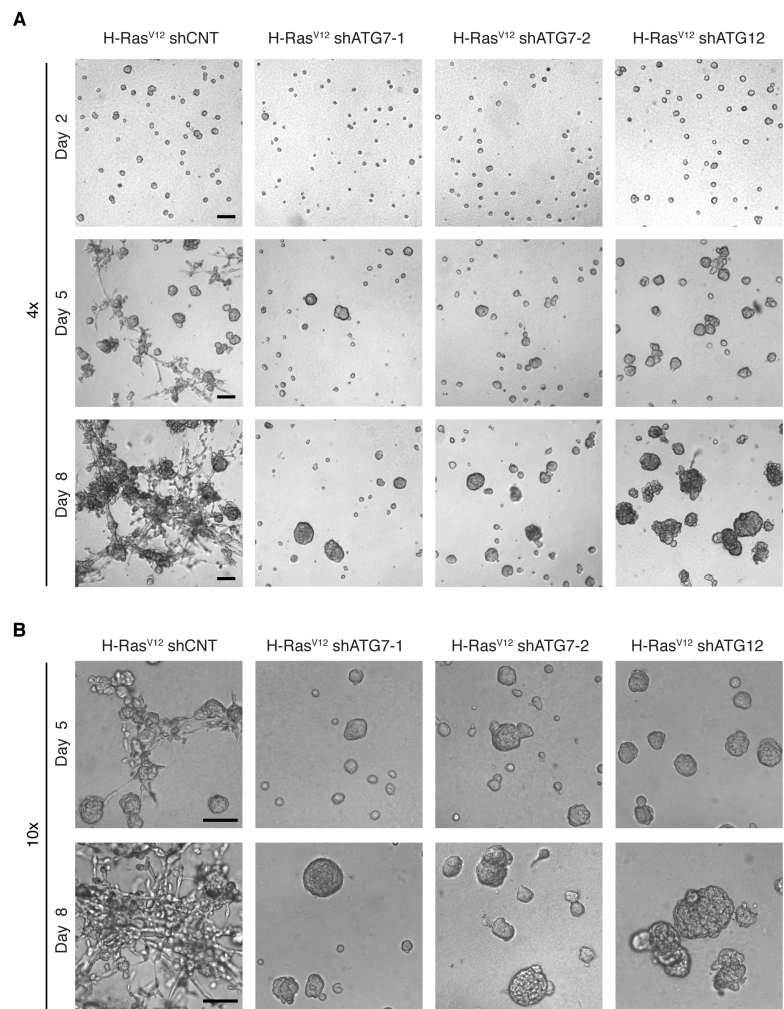
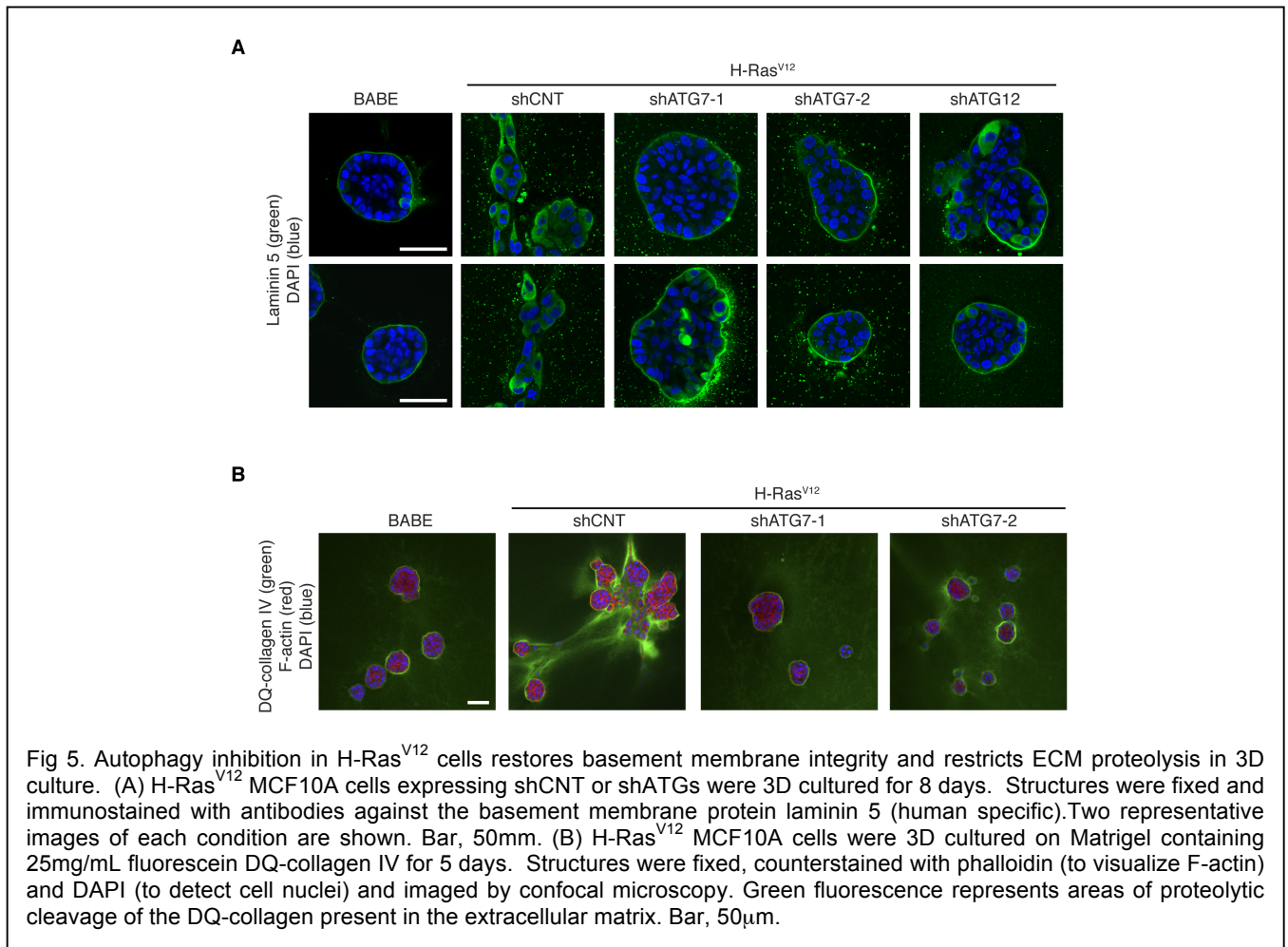
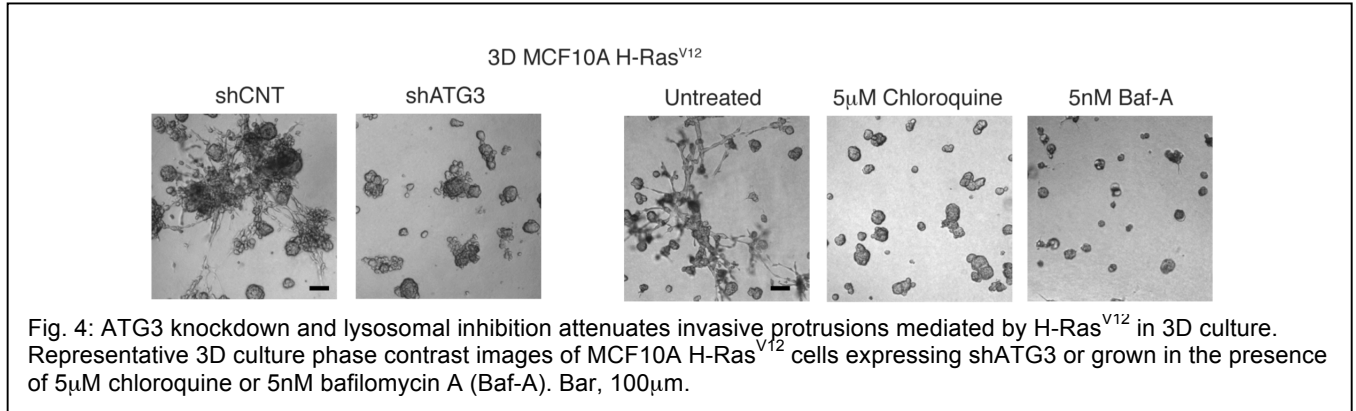

Fig 3: Autophagy is required for the formation of invasive protrusions mediated by H-Ras^{V12} in 3D culture. (A-B) H-Ras^{V12} MCF10A cells stably expressing non-targeting control shRNA (shCNT) or shRNAs against autophagy genes (shATGs) were cultured on Matrigel for the indicated number of days. Representative phase contrast images at the indicated magnifications are shown. Bar. 100µm.

this aberrant cytosolic staining pattern was especially prominent in the protrusions of H-Ras^{V12} cultures. Correlating with the decreased formation of invasive protrusions, ATG knockdown restored polarized laminin 5 secretion; based on this marker, most individual structures in ATG deficient H-Ras^{V12} cultures



were encompassed by an intact basement membrane (Fig. 5A). Hence, in addition to restricting the formation of invasive protrusions, autophagy inhibition restored polarized basement membrane secretion typically absent in H-Ras^{V12} shCNT structures.

To extend these results, we evaluated ECM proteolytic activity in control and autophagy-deficient H-Ras^{V12} cultures by assessing fluorescence emanating from the proteolytic cleavage of dye-quenched collagen IV. In control non-transformed acini (BABE), we observed a faint ring of fluorescence surrounding each structure, corresponding to collagen-IV degradation due to the normal outgrowth of acini during 3D morphogenesis. On the other hand, H-Ras^{V12} shCNT-expressing structures exhibited high levels of fluorescence that extended well beyond the immediate vicinity of individual structures (Fig. 5B). Notably, streaks of fluorescence connecting adjacent structures were frequently observed in H-Ras^{V12} shCNT cultures (Fig. 5B), which resembled the networks of invasive protrusions (Fig 3B). In contrast, H-Ras^{V12} shATG-derived structures exhibited a ring-like collagen IV degradation pattern that was restricted to the cell-ECM interface, similar to that observed in non-transformed controls (Fig. 5B). Thus, the absence of morphological protrusions in ATG deficient H-Ras^{V12} cultures was associated with the restoration of basement membrane integrity and reduced ECM proteolytic activity. Together, these findings corroborate that autophagy supports invasion of breast cancer cells in 3D culture.

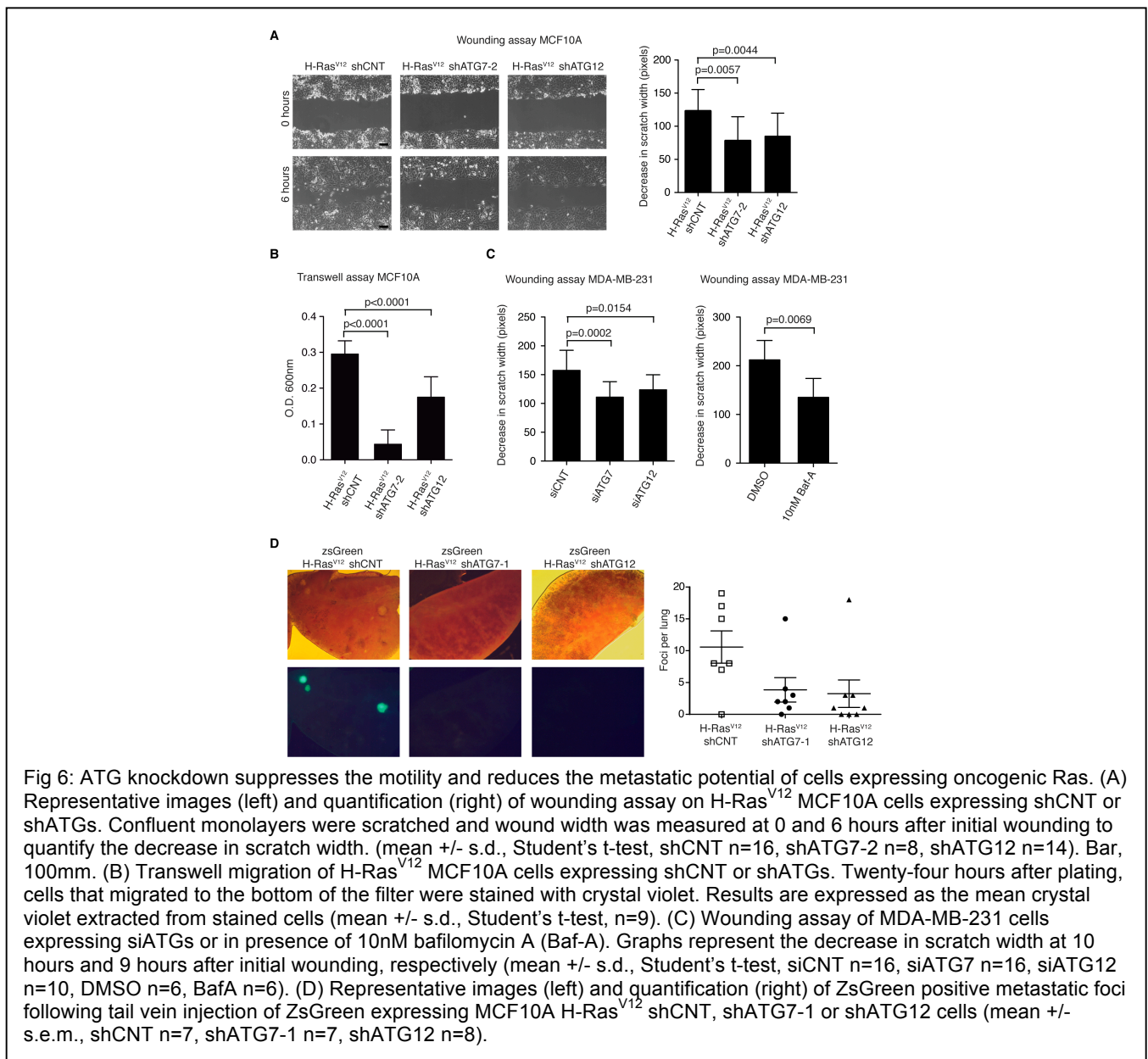
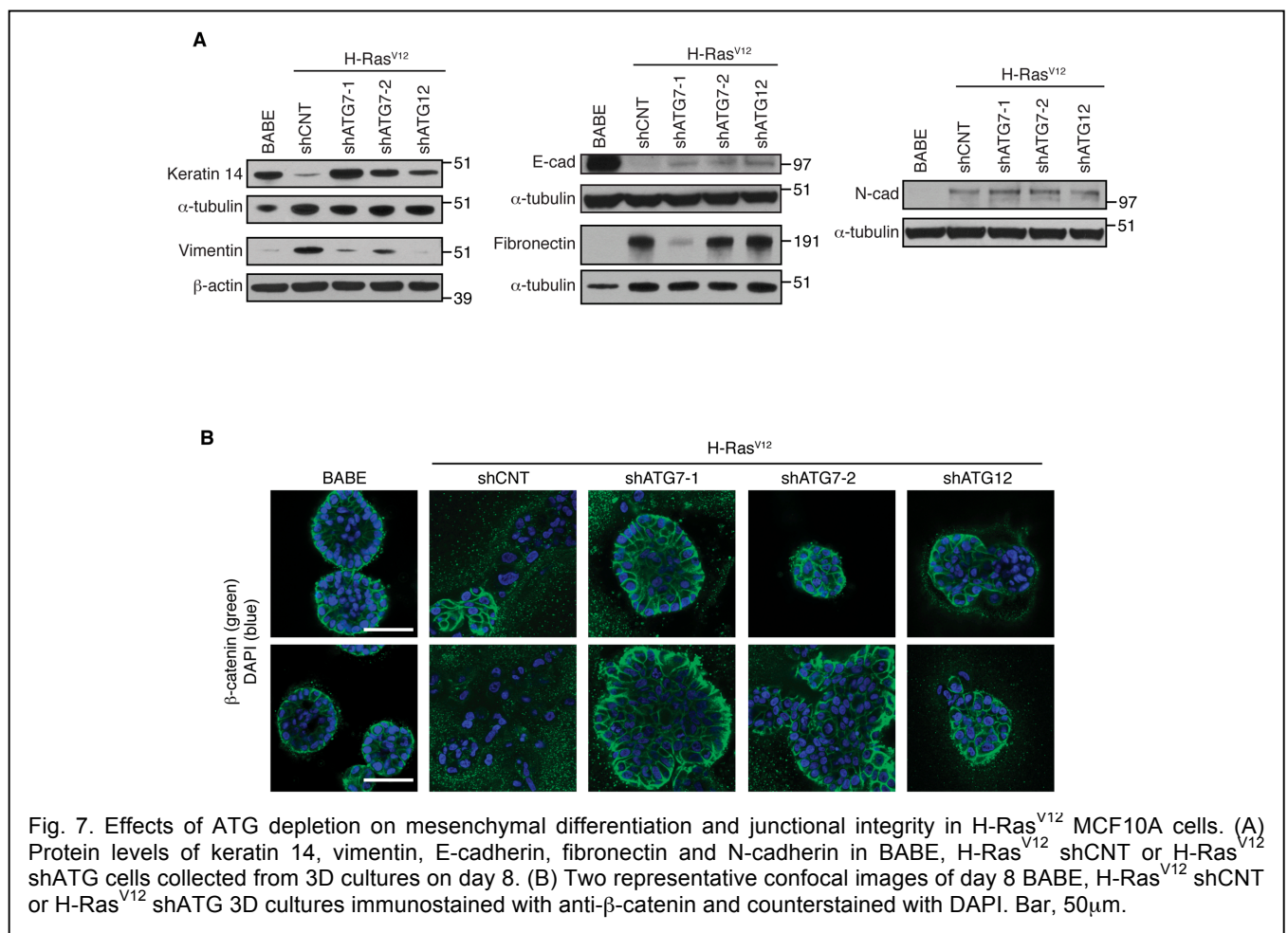

Fig 6: ATG knockdown suppresses the motility and reduces the metastatic potential of cells expressing oncogenic Ras. (A) Representative images (left) and quantification (right) of wounding assay on H-Ras^{V12} MCF10A cells expressing shCNT or shATGs. Confluent monolayers were scratched and wound width was measured at 0 and 6 hours after initial wounding to quantify the decrease in scratch width. (mean \pm s.d., Student's t-test, shCNT n=16, shATG7-2 n=8, shATG12 n=14). Bar, 100 μ m. (B) Transwell migration of H-Ras^{V12} MCF10A cells expressing shCNT or shATGs. Twenty-four hours after plating, cells that migrated to the bottom of the filter were stained with crystal violet. Results are expressed as the mean crystal violet extracted from stained cells (mean \pm s.d., Student's t-test, n=9). (C) Wounding assay of MDA-MB-231 cells expressing siATGs or in presence of 10nM bafilomycin A (Baf-A). Graphs represent the decrease in scratch width at 10 hours and 9 hours after initial wounding, respectively (mean \pm s.d., Student's t-test, siCNT n=16, siATG7 n=16, siATG12 n=10, DMSO n=6, BafA n=6). (D) Representative images (left) and quantification (right) of ZsGreen positive metastatic foci following tail vein injection of ZsGreen expressing MCF10A H-Ras^{V12} shCNT, shATG7-1 or shATG12 cells (mean \pm s.e.m., shCNT n=7, shATG7-1 n=7, shATG12 n=8).

Because defects in invasive capacity are associated with diminished cell motility, we next measured cell migration in autophagy competent and deficient breast cancer cells. Upon ATG depletion, H-Ras^{V12} MCF10A cells demonstrated an approximately 30% reduction in migratory capacity in a monolayer wound-healing assay of cell migration (Fig. 6A). Similar results were obtained using a transwell migration assay, which demonstrated a significant decrease in migration of ATG knockdown cells (Fig. 4B). We further corroborated these results using MDA-MB-231 triple negative breast cancer cells. siRNA-mediated knockdown of either ATG7 or ATG12 in MDA-MB-231 cells resulted in decreased wound closure (Fig. 6C, left). A similar decrease in MDA-MB-231 migration was also observed in the presence of the lysosomal inhibitor bafilomycin A (Fig. 6C, right). Therefore, in addition to supporting invasion of H-Ras^{V12} MCF10A cells in 3D culture, autophagy facilitates the motility of cells expressing oncogenic Ras in monolayer culture. Finally, we utilized an experimental metastasis assay to evaluate whether the effects of autophagy inhibition on invasion and migration correlated with changes in metastatic capacity *in vivo*; in support, the ability of H-Ras^{V12} MCF10A cells to produce pulmonary metastases was reduced upon ATG knockdown (Fig 6D).



Changes in epithelial differentiation have been proposed to impact the maintenance of dormant cells during lengthy periods of quiescence, as well as their exit from dormancy to produce overt metastatic disease. Given the effects of autophagy on 3D invasion, we asked if autophagy impacted epithelial differentiation by driving an epithelial-mesenchymal transition (EMT) [14,15], a process associated with increased invasive and migratory capacity *in vitro* and with metastatic capacity *in vivo* [16]. We evaluated how autophagy inhibition affects protein expression changes associated with Ras-induced EMT. We isolated BABE, H-Ras^{V12} shCNT and H-Ras^{V12} shATG7-1 expressing cells from day 8 3D

cultures and determined the protein expression of a panel of EMT associated genes by immunoblotting. In comparison to nontransformed BABE acini, H-Ras^{V12} shCNT structures displayed decreased keratin 14, an epithelial marker, and a corresponding increase in the mesenchymal protein, vimentin (Fig 7A). ATG knockdown reversed these H-Ras^{V12} - driven changes in differentiation, resulting in an increase in keratin 14 protein levels and a corresponding decrease in vimentin levels compared to H-Ras^{V12} shCNT cells isolated from 3D culture (Fig. 7A). However, autophagy inhibition had minimal effects on other EMT markers that were altered by oncogenic Ras expression. Only a slight increase in E-cadherin levels was observed in shATG cells, decreased fibronectin was only observed in shATG7-1 expressing cells, and N-cadherin protein levels were unchanged following ATG knockdown (Fig. 7A). During EMT, cells commonly lose the ability to form cell-cell junctions [17]. Therefore, we analyzed the effects of autophagy inhibition on cell-cell junctional integrity in H-Ras^{V12} 3D structures by immunostaining for b-catenin. Normal MCF10A acini (BABE) displayed strong b-catenin staining at cell-cell contacts, indicating intact adherens junctions, whereas the expression of H-Ras^{V12} resulted in a near-complete loss of β -catenin junctional staining; in these cultures, only isolated focal areas of junctional β -catenin staining were observed (Fig. 7B). Upon ATG knockdown in H-Ras^{V12} structures, both the expression and junctional localization of b-catenin were significantly restored (Fig. 7B). Based on these results, we conclude that autophagy inhibition modulates certain aspects of mesenchymal differentiation in Ras-transformed cells in 3D culture, most notably the suppression of vimentin, as well as the restoration of keratin 14 expression and epithelial cell-cell contacts. However, autophagy deficiency does not broadly suppress EMT. We recognize that these findings have implications for the transition from dormant to overt metastasis in late recurrent disease. Thus, in future years we will use the in vivo models we are generating to further investigate this fundamental issue as part of subtasks 1j and 2c.

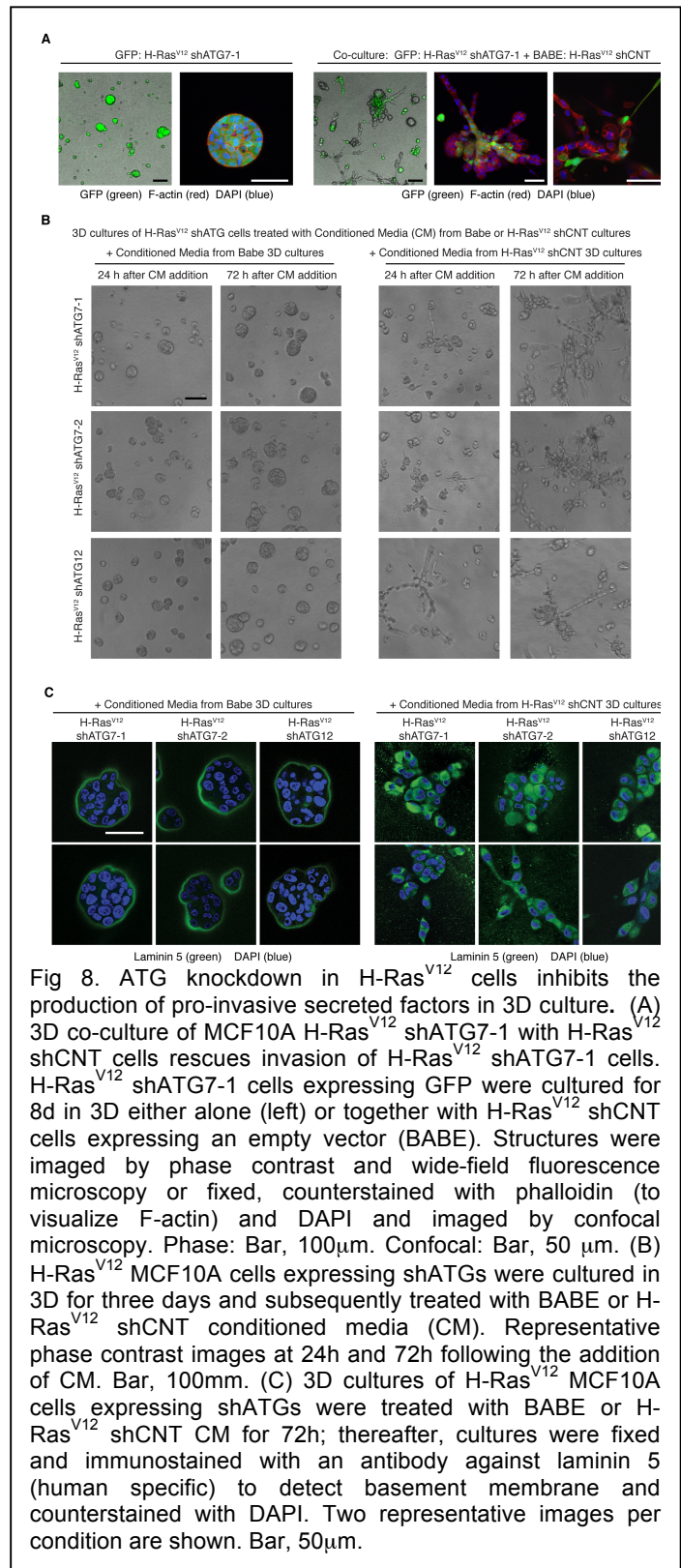

Cell migration and invasion involves the secretion of multiple factors that cooperate to promote motility and to degrade the surrounding ECM [18,19]. To ascertain if defects in Ras-driven invasion observed following autophagy suppression were the result of decreased production of pro-invasive factors, we performed a co-culture assay in which H-Ras^{V12} shATG7-1 cells (co-expressing GFP for tracking purposes) were combined with H-Ras^{V12} shCNT cells. Whereas H-Ras^{V12} shATG7-1-GFP cells cultured alone grew as spherical structures (Fig. 8A, left panels), upon co-culture with H-Ras^{V12} shCNT cells, H-Ras^{V12} shATG7-1-GFP structures became dispersed and formed invasive protrusions (Fig. 8A, right panels). Hence, we hypothesized that factors from neighboring H-Ras^{V12} shCNT cells are sufficient to rescue *in trans* the invasion defect in H-Ras^{V12} shATG7-1 cells. To further test this prediction, we grew H-Ras^{V12} shATG cells in 3D culture for 3 days and subsequently treated these structures with conditioned media (CM) produced from either BABE or H-Ras^{V12} shCNT cultures. H-Ras^{V12} shATG structures remained as compact spheres following treatment with BABE CM (Fig. 8B, left). In contrast, CM from H-Ras^{V12} shCNT cultures led to the formation of invasive protrusions at 24h following treatment, which became fully evident by 72h (Fig. 8B, right). Furthermore, basement membrane integrity was lost in ATG knockdown cells treated with H-Ras^{V12} shCNT CM, as evidenced by cytosolic laminin 5 staining (Fig. 8C). These findings demonstrate that autophagy inhibition in H-Ras^{V12} cells inhibits the production of secreted factors required for Ras-driven invasion in 3D culture.

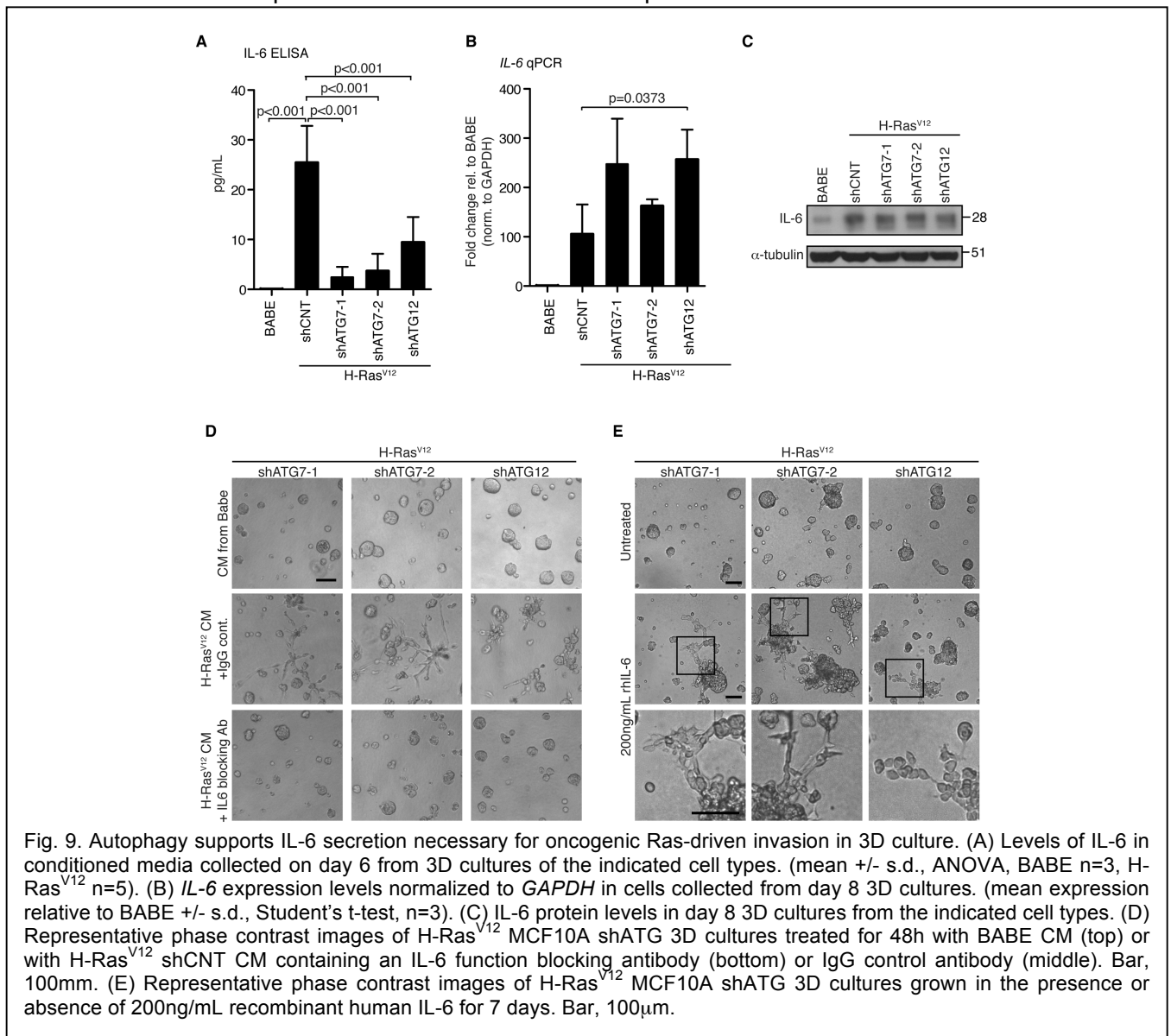

ATG depletion inhibits IL-6 production following acute oncogenic Ras activation in IMR90 fibroblasts, indicating autophagy supports the production of IL-6 in response to oncogenic Ras activation [20]. Because IL-6 has been demonstrated to promote migration and invasion, and also drive epithelial-mesenchymal transition [21-23], we tested whether IL-6 levels were altered in H-Ras^{V12} shATG 3D cultures. Analysis of IL-6 in conditioned media collected from 3D cultures by ELISA indicated a significant reduction in secreted IL-6 levels in H-Ras^{V12} shATG-expressing cultures compared to H-Ras^{V12} shCNT cultures (Fig. 9A). Furthermore, this decrease in secreted IL-6 was not the result of reduced *IL-6* gene expression; in fact, qPCR analysis revealed that *IL-6* transcript levels in H-Ras^{V12} shATG cells were increased, rather than decreased, in comparison to H-Ras^{V12} shCNT cells (Fig 9B). Notably, studies of Ras-induced senescence similarly demonstrated that autophagy deficient cells do not exhibit reduced *IL-6* transcript levels; instead, they found decreased levels of IL-6 protein, which were proposed to be due to impaired IL-6 translation [20,24]. In contrast to those results, we uncovered that ATG depletion did not attenuate IL-6 protein levels in Ras-transformed cells grown in 3D culture (Fig 9C), indicating that autophagy facilitates the secretion of IL-6 during H-Ras^{V12} 3D morphogenesis.

To ascertain the functional significance of these results, we interrogated whether IL6 was necessary and sufficient for H-Ras^{V12}-driven invasion in 3D culture. First, we treated H-Ras^{V12} shATG structures with H-Ras^{V12} shCNT CM in the presence versus absence of an IL-6 function-blocking antibody. The addition of an IL-6 function-blocking antibody attenuated the ability of H-Ras^{V12} shCNT CM to promote invasive protrusions in H-Ras^{V12} shATG cultures, whereas an IgG isotype control had no effect (Fig. 9D). In parallel, we tested whether treatment with exogenous IL-6 was sufficient to restore invasion in H-Ras^{V12} shATG expressing cells during 3D morphogenesis. Addition of recombinant IL-6 to 3D cultures of H-Ras^{V12} shATG7 and shATG12 cells disrupted structure integrity, resulting in large globular structures, and enhanced the formation of invasive protrusions compared to their untreated counterparts (Fig. 9E). Overall, these results indicate that autophagy promotes the efficient secretion of IL-6 by H-Ras^{V12} cells in 3D culture, which is necessary for invasion. We are currently preparing these results for publication and further corroborating these results in the triple negative breast cancer cell lines, MDA-MB-231 and Hs578.

Overall, the major accomplishment from the 3D studies conducted in subtasks 1a and 1b is our identification of two opposing, context-dependent functions for autophagy that will potentially influence late recurrent metastatic progression. On the one hand, in breast tumors driven by the PI3K pathway, autophagy restricts proliferation and maintains a quiescent state. On the other, in tumors with hyperactivation of the Ras/MAPK pathway, autophagy has minimal effects on proliferation; rather, it promotes invasive behavior and alters epithelial differentiation and secretion. We anticipate that these key mechanistic insights will critically direct our in vivo studies; specifically, we will place high priority on precisely defining and elaborating these two opposing biological functions in vivo during analysis of the autophagy pathway in the transgenic breast models we have generated. In addition to these crucial and exciting mechanistic insights, an important goal of subtask 1b was to identify 1-2 human cell lines that exhibit quiescent behavior in 3D culture. As reported in the 2012 Annual Progress Report, the cell lines that best meet this criteria are MCF7 and T47D, both luminal breast cancer, because they exhibit reduced rates of proliferation compared to other cell types. Although we do not currently anticipate the need to identify additional human cell lines in this sub-task, we will be able to continue to further testing of additional human cell lines using this 3D system if the future need arises.

- c. Optimize protocols for the stable ex vivo transduction of fluorescent (e.g., GFP), luminescent (e.g. luciferase), and drug resistant (e.g., puromycin) marker proteins into human cancer cell lines. (Months 1-12).**

This sub-task was completed during year 1. The optimized protocols were detailed in the 2012 Annual Progress Report.

- d. **For human cells in subtask 1b that exhibit a low proliferation index in 3D culture, introduce cells (containing fluorescent and/or drug resistance marker proteins) into the systemic circulation of immunodeficient mice and determine the latency period to the onset of metastasis. (Months 13-36; Revised timeline: Months 36-48).**

Based on our studies in subtask 1b during years 1 and 2, we propose that the luminal breast cancer lines MCF7 and T47D will be the most useful for these subtask 1d and 1e. Because of the unexpected results regarding autophagy that we obtained in our 3D culture studies, as well as in vivo results from PyMT cells described below in subtask 2b, we chose to defer the initiation of these studies until we obtain more robust data from the PyMT model in sub-tasks 2b and 2c which we anticipate will occur during year 3 of the award. We have prioritized the studies from PyMT tumors regarding late recurrent disease because it is an immunocompetent, syngeneic model. Thereafter, we will be better poised to pursue salient issues in a more tactical manner in these immunodeficient models; because it harbors a oncogenic PI3K mutation, we anticipate that the MCF7 cell line will be the most appropriate if our studies in subtasks 2b and 2c confirm that autophagy impedes, rather than promotes, late recurrent growth in the PyMT model.

- e. **Isolate late onset macro-metastatic tumors and dormant tumor cells from subtask 1d, and obtain gene expression profiles. To obtain dormant cells from each cohort in subtask 1d, five to seven (5-7) tumor cell bearing mice will be euthanized at an intermediate timepoint (anticipated to occur at six to nine (6-9) months post initial injection but prior to overt metastatic disease), cancer cells isolated from host tissues, and if required, expanded ex vivo (Months 42-54).**

These studies have not been initiated. Because subtask 1d is being delayed to pursue studies in the PyMT model, we have revised the timeline for subtask 1e accordingly.

- f. **Generate transgenic mice expressing MMTV-PyMT (Polyoma Middle T) and ROSA26-LSL-RFP in a pure genetic background (C57B/6). (Months 1-12).**

During year 2, we completed the generation of these compound transgenic mice. The genotyping gel in Fig.10 shows a representative mouse (Mouse 3750) from a typical litter that expresses both of the desired alleles. We are utilizing the Cre reporter mouse strain called ROSA26-LSL-RFP mice in order to track cells in vivo. Thus, PyMT cells and tissues possess a red fluorescent protein (tandem RFP) reporter targeted to the ROSA26 locus in which transcription of the protein is prevented via *loxP*-flanked STOP cassette (LSL-RFP); upon Cre-mediated excision of this cassette, either in vivo or ex vivo, cells exhibit red fluorescence. Because of concerns that the fluorescent intensity of R26-LSL-RFP appeared reduced in tissue sections, we also interbred a constitutively expressed cyan fluorescent protein (β -actin CFP) with these alleles as an alternative fluorescent marker with potentially improved brightness for the tracking of solitary tumor cells and micrometastatic lesions in the absence of Cre-recombination (for example, see Fig. 11 in sub-task 1i).

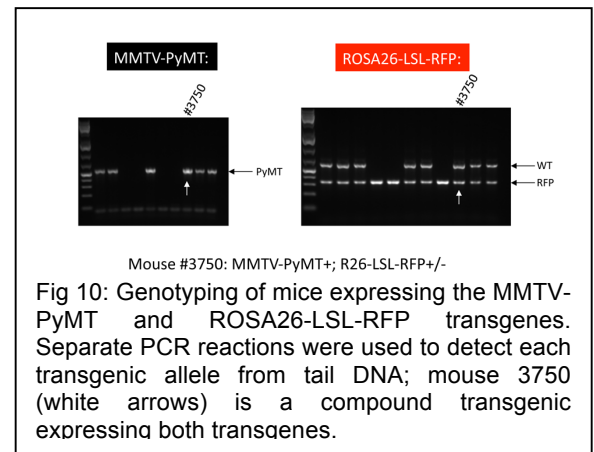

As we reported in the 2012 Annual Progress Report, our PCR-based fragment length polymorphism (FLP) microsatellite genotyping studies indicate that the mice are in a pure C57B/6 genetic background. Our prediction is that the delayed kinetics of tumor progression in C57B/6 mice will allow us to model late recurrence and investigate dormant tumor cell behavior in an immunocompetent background. An important advantage afforded by this mammary cancer model is the ability to transplant either intact tumors or tumor

cells following ex vivo manipulation into syngeneic recipient host animals, hence allowing isolated tumor cells to establish residence in host tissues in a relatively synchronous manner. As described in the sub-tasks below, we have begun to utilize these animals to generate primary breast tumor tissue for the studies proposed in the years ahead. We have also completed the interbreeding of the MMTV-PyMT, R26-LSL-RFP mice with the ATG12 and ATG5 conditional mice, which is described below in subtask 2a.

g. Establish routine isolation and short-term culture conditions for normal and neoplastic mouse mammary epithelium. (Months 1-12).

This sub-task was completed during year 1. The optimized protocols have been detailed in the 2012 Annual Progress Report.

h. Optimize protocols for the stable ex vivo transduction of Cre recombinase and fluorescent, luminescent, and/or drug selection marker proteins into normal and neoplastic mouse mammary epithelium. (Months 1-12).

This sub-task was completed during year 1. The optimized protocols have been detailed in the 2012 Annual Progress Report.

i. Isolate neoplastic epithelium from female transgenic mice generated in subtask 1f and transplant into syngeneic C57B/6 host recipient animals. (Months 13-24).

We have successfully transplanted PyMT tumor epithelium generated in subtask 1f into female C57B/6 host animals for both experimental metastasis (tail vein) and spontaneous metastasis (fat pad transplantation) assays. For these studies, we used MMTV-PyMT tumors that co-expressed cyan fluorescent protein (β -actin CFP), because this fluorescent marker exhibited improved brightness for the tracking of solitary tumor cells and micrometastatic lesions in the absence of Cre-recombination. For the experimental metastasis assays, we verified that following intravenous injection of primary PyMT tumor cells into the circulation; these cells were confirmed to be seeded into the lungs at 2 weeks post-injection and to form lung metastases in syngeneic, wild type C57B/6 hosts at later time points (Fig. 11). Second, we have analyzed a spontaneous metastasis assay at 12 weeks following fat pad transplantation. Although we have not detected tumor cells in intact lung tissue or upon H&E staining of tissue sections, we have generated single cell suspensions from these lungs and confirmed the presence of isolated CFP-positive PyMT tumor cells residing within the lung tissue of recipient mice; this low level of tumor cell seeding

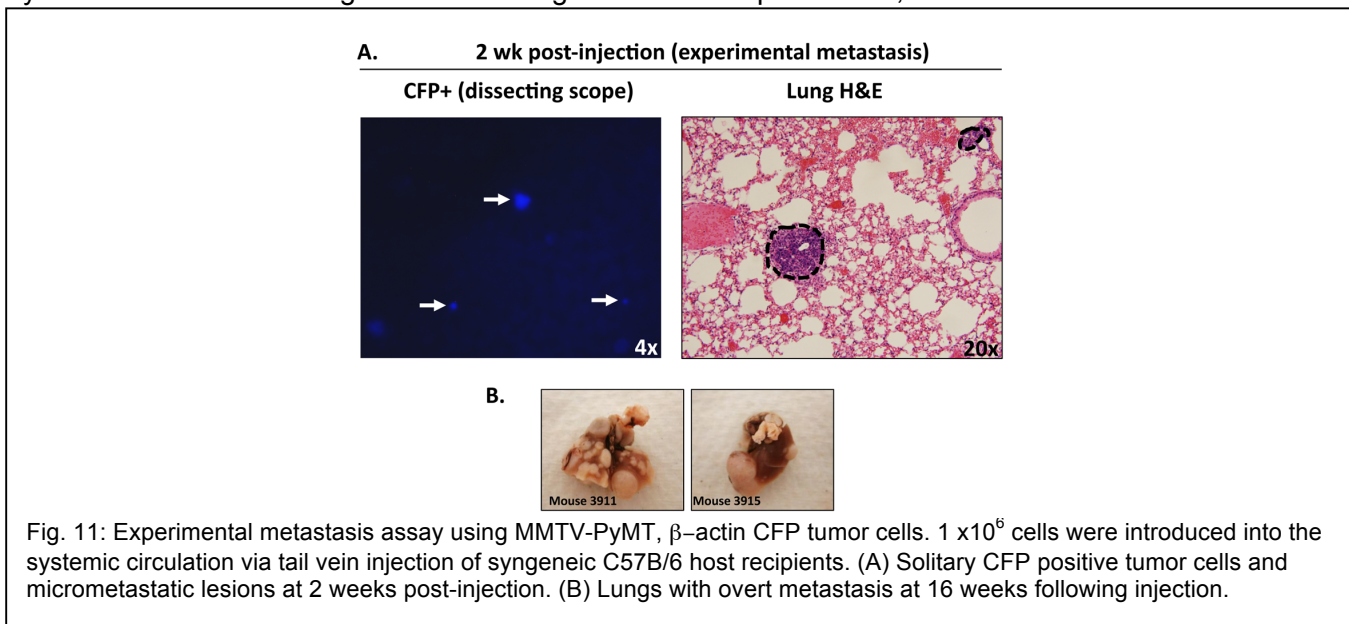

suggests that metastatic disease will potentially develop over an extended period (Fig. 12). Overall, we have established that our transplantation of donor tumor cells into immunocompetent C57B/6 host animals will be suitable for the studies proposed in subtasks 1j and 2c. Currently, we are transplanting tumors into a cohort of syngeneic C57B/6 host recipient animals and will await the development of overt, metastasis for the studies in subtask 1j. Consistent with our goal to generate a model of late recurrence, we anticipate the onset of metastasis will occur over an extended time course.

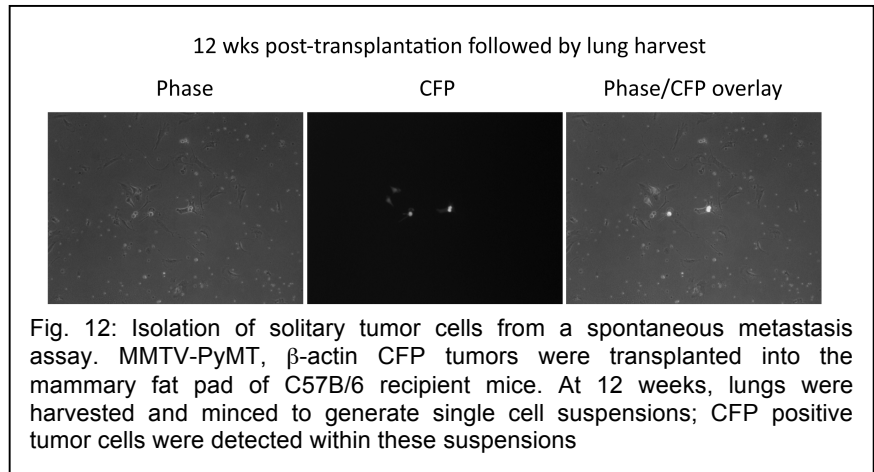

- j. Determine the latency period to the onset of metastasis for recipient mice generated in subtask 1i. Fifteen (15) mice will be functionally evaluated for altered characteristics of histopathologic progression from primary to metastatic disease (mammary morphogenesis, epithelial cell proliferation/cell death, overt tumor formation, tumor burden, tumor type, and development/latency to metastases) (Months 25-36).**

These studies have been planned for year 3.

- k. Isolate late onset macro-metastatic tumors and dormant tumor cells from mice in subtask 1i, and obtain gene expression profiles. To obtain dormant cells from subtask 1i, ten (10) tumor cell bearing mice from 1i will be euthanized at an intermediate timepoint (anticipated to occur at six to nine (6-9) months post fat pad transplantation but prior to overt metastatic disease), cancer cells isolated from host tissues, and if required, expanded ex vivo (Months 37-48).**

These studies have not been initiated.

Task 2. Determine the requirement for autophagy in the survival of dormant breast cancer cells.

- a. Generate transgenic mice expressing MMTV-PyMT (Polyoma Middle T), ROSA26-LSL-RFP, and conditional null alleles (floxed) of autophagy regulators (e.g., *atg12* and *atg5*) in a pure genetic background (C57B/6). (Months 1-24).**

We have completed the interbreeding of the mice to generate the compound transgenic mice necessary for these studies. The genotyping gels in Fig. 13 show representative mice expressing the ATG12 floxed alleles, the Polyoma Middle T (PyMT) transgene and R26-LSL-RFP. As reported in the 2012 Annual Progress Report, the strains used for this interbreeding were backcrossed into the C57B/6 background prior to this intercross; hence, donor epithelium isolated from compound transgenic tumors is suitable for transplantation into C57B/6 host animals. In addition, we have also created tumor-bearing animals that possess a cyan fluorescent protein driven by the beta-actin promoter (β -actin-CFP) to assist with tracking tumor cells in vivo. As reported in the 2012 Annual Progress Report, we developed the protocols to harvest and freeze down tumor tissue for cryostorage in subtask 1g; the isolated cells from these donor tumors can be stored for extended periods, thawed, expanded and reintroduced into syngeneic recipient animals at a later date. As a result, over the past year, we have harvested tumors from donor animals for our transplantation studies proposed in subtasks 2b and 3a. Table 1 shows the genotypes for some of the key tumors we have generated from donor animals. In addition to these tumors containing *atg12^{ff}* or *atg5^{ff}*,

we also possess donor epithelium from autophagy competent tumors (*atg5/12+/+* or *f/+*) to utilize as controls. Lastly, we have generated mice containing the doxycycline-inducible Cre recombinase (WAP-rtTA-Cre) along with the ATG12 floxed alleles and R26-LSL-RFP as shown in Fig. 14; in contrast to ex vivo deletion using Cre recombinase, these animals will allow us to delete ATGs following their introduction into recipient animals, and thus, investigate the effects of ATG deletion in a temporal-specific manner at later stages. Tumors from these WAP-rtTA-Cre animals have also been frozen down (Table 1). We will continue to isolate tumors from the various genotypes and expand this frozen bank of tumor tissue. Overall, subtask 2a has been successfully completed and we now possess an abundant source of PyMT tumor tissue in which we can genetically ablate autophagy in a tumor cell specific manner for our proposed subtasks in the upcoming years; moreover, in the case of WAP-rtTA-Cre animals, we can also conduct studies of ATG deletion in a temporal-specific manner if the need arises.

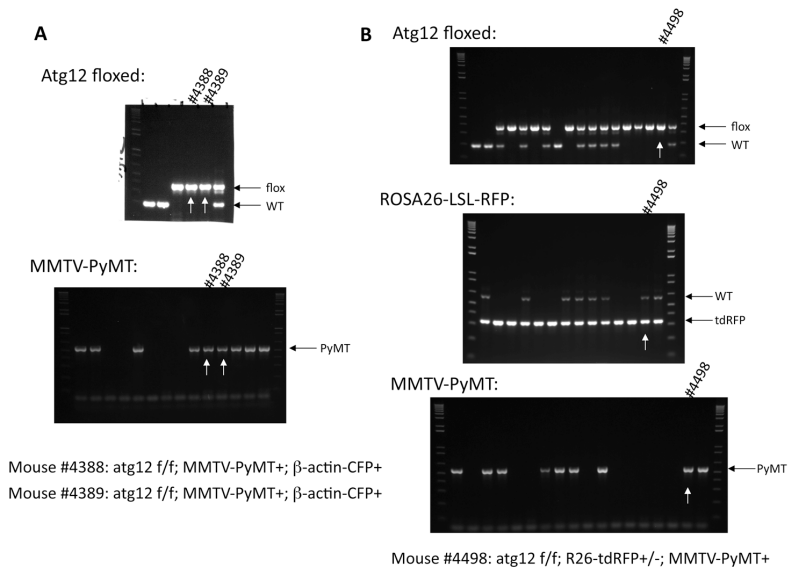
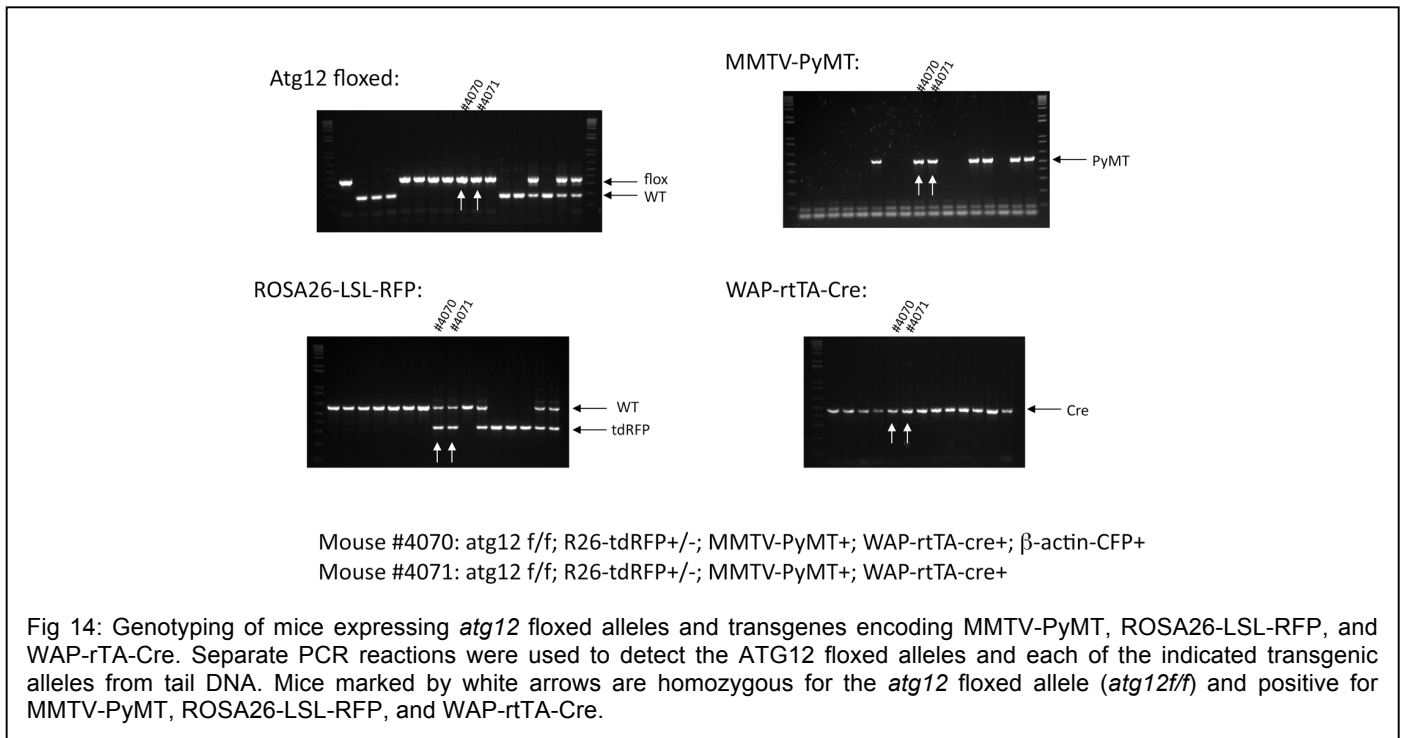

Fig 13: Genotyping of mice expressing *atg12* floxed alleles and transgenes encoding MMTV-PyMT and ROSA26-LSL-RFP. Separate PCR reactions were used to detect the ATG12 floxed alleles and each of the indicated transgenic alleles from tail DNA. (A) Mice homozygous for the *atg12* floxed allele (*atg12 f/f*) and MMTV-PyMT are indicated by the white arrows; these mice also contain the β -actin CFP transgene. (B) Mouse 4498, indicated by the white arrow, is homozygous for the *atg12* floxed allele (*atg12 f/f*) and positive for MMTV-PyMT and ROSA26-LSL-RFP.

Table 1: Genotypes of PyMT Donor Epithelium

Date Frozen	Tumor (Mouse ID)	Genotype
11/10/2012	2385	<i>atg12 f/f</i> ; MMTV-PyMT+
11/15/2012	2446	<i>atg12 f/f</i> ; MMTV-PyMT+; β -actin-CFP+
1/23/2013	2848	<i>atg12 f/f</i> ; R26-tdRFP+/-; MMTV-PyMT+
2/20/2013	2800	<i>atg12 f/f</i> ; R26-tdRFP+/-; MMTV-PyMT+; β -actin-CFP+
2/20/2013	2938	<i>atg5 f/f</i> ; MMTV-PyMT+
4/29/2013	3259	<i>atg12 f/f</i> ; R26-tdRFP+/-; MMTV-PyMT+; β -actin-CFP+
5/6/2013	3306	<i>atg5 f/f</i> ; MMTV-PyMT+; β -actin-CFP+
6/10/2013	3305	<i>atg5 f/f</i> ; MMTV-PyMT+; β -actin-CFP+
6/27/2013	3529	<i>atg12 f/f</i> ; R26-tdRFP+/-; MMTV-PyMT+; WAP-rtTA-Cre+
8/12/2013	3799	<i>atg12 f/f</i> ; R26-tdRFP+/-; MMTV-PyMT+; WAP-rtTA-Cre+



- b. Using techniques optimized in subtasks 1g-i, isolate neoplastic epithelium from female transgenic mice generated in subtask 2a, transduce with Cre recombinase, and transplant into cleared mammary fat pads of syngeneic C57B/6 host recipient animals. For this subtask, we anticipate that at least ten (10) mice from each transgenic donor will be utilized for epithelial isolation and at least twenty five (25) host recipient animals per cohort will be utilized for fat pad transplantation (Months 19-36).**

We have initiated the experiments for this subtask. As reported in the 2012 Annual Progress Report, we conducted control experiments to verify that ex vivo Cre-mediated deletion of *atg12* leads to a block in autophagy in PyMT tumor harvested from mice, evidenced by the loss of PE-lipidated LC3 (LC3-II) (Fig. 15). This analysis is underway for *atg5* deletion in PyMT tumors. Thus, the donor epithelium is suitable for determining the functional contribution of deficient autophagy to metastasis and we will be able to evaluate the effects of autophagy deletion on the onset of late recurrent metastasis in recipient mice. In addition to these studies using primary tumor-derived cells and tissues, we pursued complementary strategies in PyMT-derived cell lines over year 2. This was largely motivated by our three-dimensional culture studies in subtasks 1a and 1b demonstrating that mammary epithelial cells expressing oncogenic PI3K exhibited increased rates of proliferation upon autophagy inhibition in 3D culture, including cells that would be normally quiescent due to pharmacological inhibition of the mTORC1 pathway [4]. These results indicated autophagy inhibition paradoxically promote the active growth of dormant cells, which we hypothesized would lead to an increase in the rate of metastatic outgrowth in vivo. We chose to test this hypothesis in PyMT-derived cell lines because the PyMT oncogene strongly activates the PI3K/AKT pathway in breast cancer cells, making it a

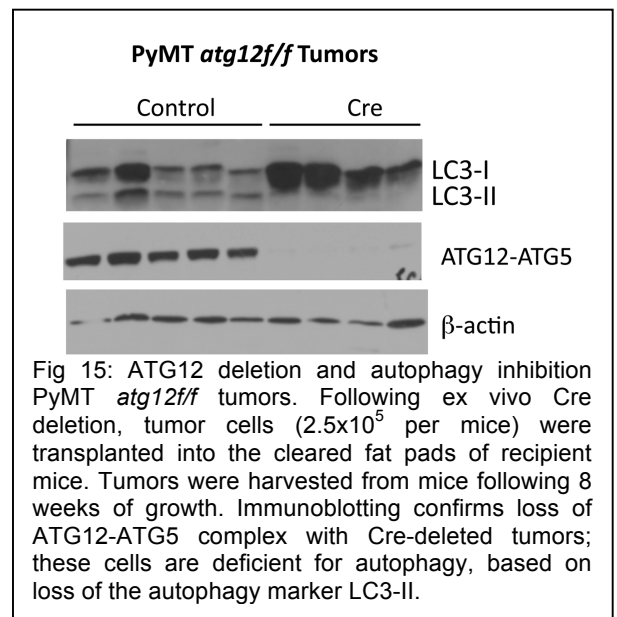

logical model to pursue these studies. We obtained a PyMT mouse tumor cell line (R221A from Barbara Fingleton, Vanderbilt University) that can be transplanted into syngeneic hosts for analysis of metastasis phenotypes. To inhibit autophagy in these cells, we expressed an shRNA against ATG7 (shATG7) for stable RNAi-mediated silencing of this the essential autophagy regulator. We confirmed that basal and induced autophagy was reduced in ATG7 knockdown cells (Fig 16). Moreover, shATG7 cells exhibit increased rates of (anoikis), suggesting that autophagy may contribute to the survival of detached cells in the systemic circulation (Fig. 17). Despite the effects of autophagy in promoting cell survival, we have uncovered that autophagy inhibition promotes, rather than impedes the metastasis of PyMT cells in vivo. Analysis of H&E stained lungs indicates that mice injected with control or shATG7 cells have established, prominent macrometastatic growths. However, there is a significantly increased number of these macrometastases in mice injected with shATG7 cells. This result is reproducible over multiple experiments and was obtained using both an experimental metastasis model (Fig. 18-19) and spontaneous metastasis model (Fig. 20). Lesions from shATG7 cells were on average larger compared to lesions in mice injected with control cells (Fig. 19). As a control, we have isolated metastatic lesions from the lung and confirmed that the R221-shATG7 derived metastases continue to exhibit impaired autophagy (Fig. 18, right and Fig. 20C). Moreover, the increase in metastasis is not dependent on differences in primary tumor growth in the spontaneous metastasis model, as both autophagy competent and deficient cells exhibit similar tumor growth kinetics in these experiments (Fig. 21). These findings are consistent with the hypothesis that decreased autophagy promotes metastasis following lung colonization, potentially by initiating active outgrowth of solitary cells into overt metastases. We will further scrutinize this possibility in the upcoming year and confirm this important result using the primary tumors generated in subtask 2a; overall, these RNAi depletion studies corroborate studies with PI3K-H1047R in 3D culture and lay the foundation for our studies in subtask 2c.

Finally, during year 2, we generated an immortalized cell line from one of the PyMT tumors isolated in our laboratory. Importantly, this line was created without the addition of any immortalization factors or oncogenes; instead a PyMT derived cell line that morphologically resembled primary tumor cells was isolated over time via serial passages. Moreover, this cell line is homozygous for the ATG12 floxed alleles and contains the LSL-RFP reporter as well as β -actin-CFP for tracking purposes (Fig. 22A). Moreover, upon transduction of adenoviral Cre, we have observed the loss of ATG12 and autophagy inhibition, evidenced by reduced PE-lipidated LC3 (LC3-II) and the accumulation of p62 (Fig. 22B). When introduced into syngeneic recipient mice via tail vein injection, we have observed the presence of micro-metastatic lesions in the lung after 5 weeks (Fig. 22C) and successfully cultured tumor cells isolated from host lung tissue. In contrast to cell lines created by other research groups, this cell line is uniquely tailored for our studies of autophagy during metastasis and late recurrence; we anticipate that this line will be utilized to mechanistically follow-up the phenotypes obtained from our initial experiments using primary tumor-derived tissue.

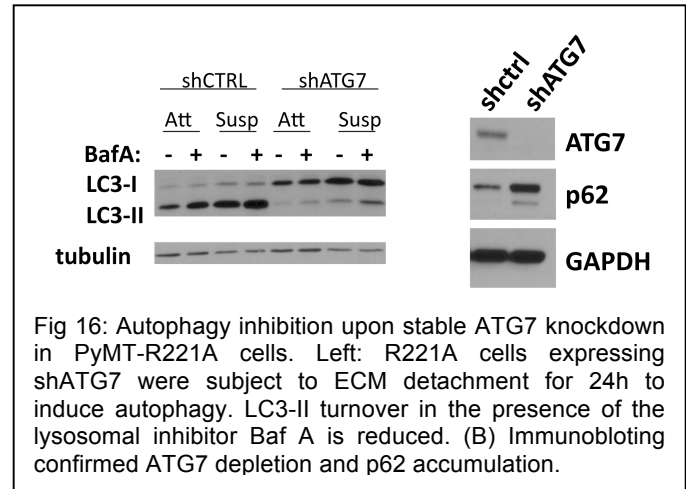

Fig 16: Autophagy inhibition upon stable ATG7 knockdown in PyMT-R221A cells. Left: R221A cells expressing shATG7 were subject to ECM detachment for 24h to induce autophagy. LC3-II turnover in the presence of the lysosomal inhibitor Baf A is reduced. (B) Immunoblotting confirmed ATG7 depletion and p62 accumulation.

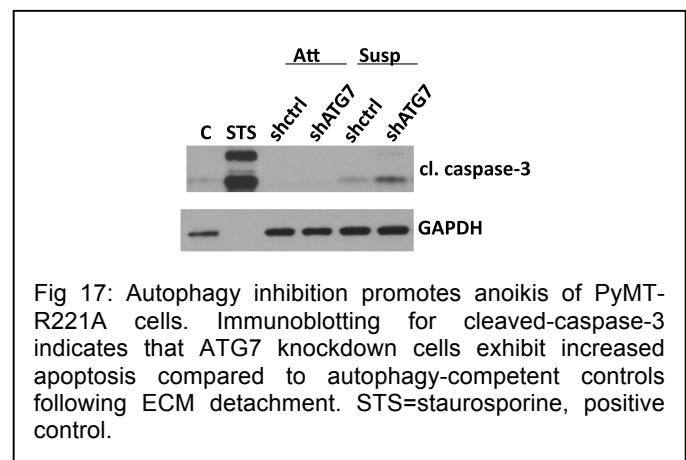

Fig 17: Autophagy inhibition promotes anoikis of PyMT-R221A cells. Immunoblotting for cleaved-caspase-3 indicates that ATG7 knockdown cells exhibit increased apoptosis compared to autophagy-competent controls following ECM detachment. STS=staurosporine, positive control.

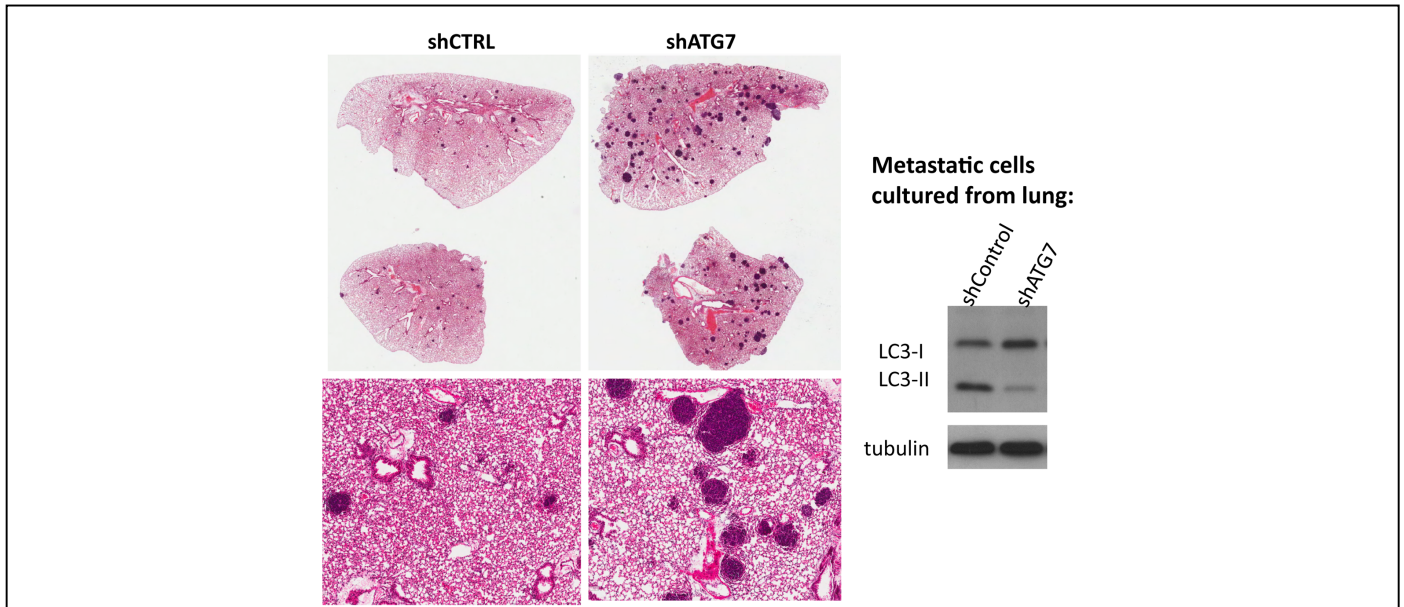

Fig 18: Increased lung metastasis in an experimental metastasis assay following ATG7 knockdown in PyMT-R221A cells. Left: H&E sections of pulmonary metastasis in control (shCTRL) and autophagy deficient cells (shATG7). Right: LC3-II immunoblotting confirms that autophagy inhibition is maintained in metastatic cells isolated from the lung.

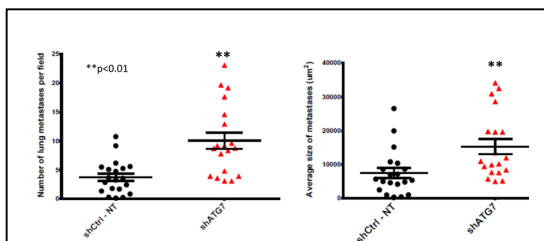

Fig. 19: Increased lung metastasis in an experimental metastasis assay following ATG7 knockdown in PyMT-R221A cells. Quantification of the number of lung metastasis and average size of metastatic lesions. Data is from 3 independent experiments n=20 mice for shCTRL and n=19 mice for shATG7

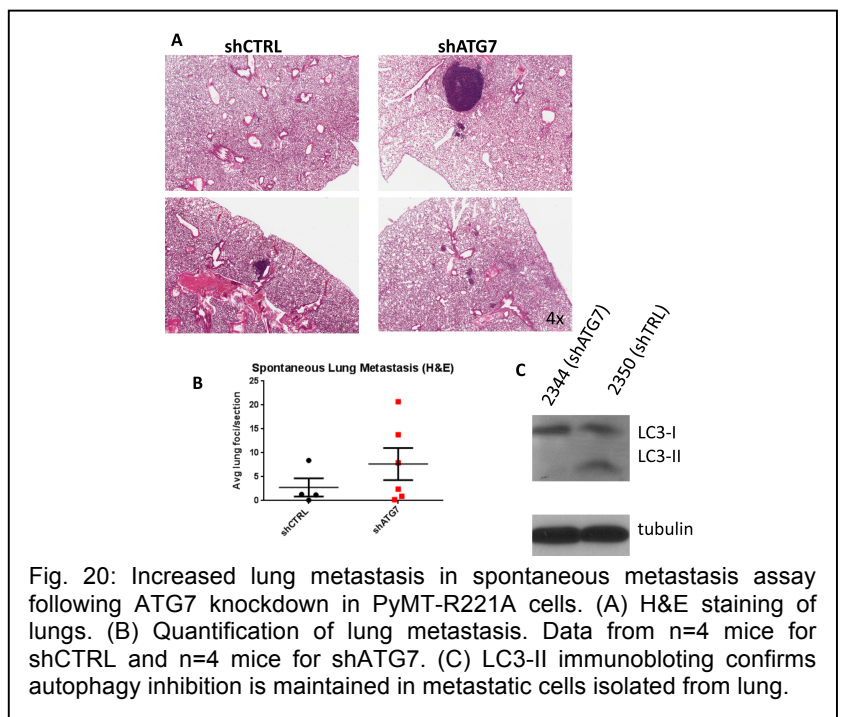

Fig. 20: Increased lung metastasis in spontaneous metastasis assay following ATG7 knockdown in PyMT-R221A cells. (A) H&E staining of lungs. (B) Quantification of lung metastasis. Data from n=4 mice for shCTRL and n=4 mice for shATG7. (C) LC3-II immunoblotting confirms autophagy inhibition is maintained in metastatic cells isolated from lung.

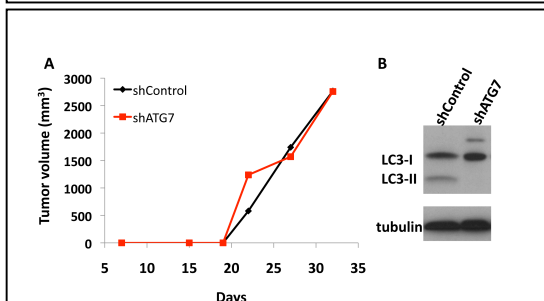

Fig. 21: Autophagy inhibition does not impact primary tumor growth. (A) PyMT-R221A cells were transplanted into the mammary fat pad of syngeneic hosts and tumor volume was measured at the indicated days. (B) LC3-II immunoblotting from tumor lysates to validate autophagy inhibition in shATG7 cells.

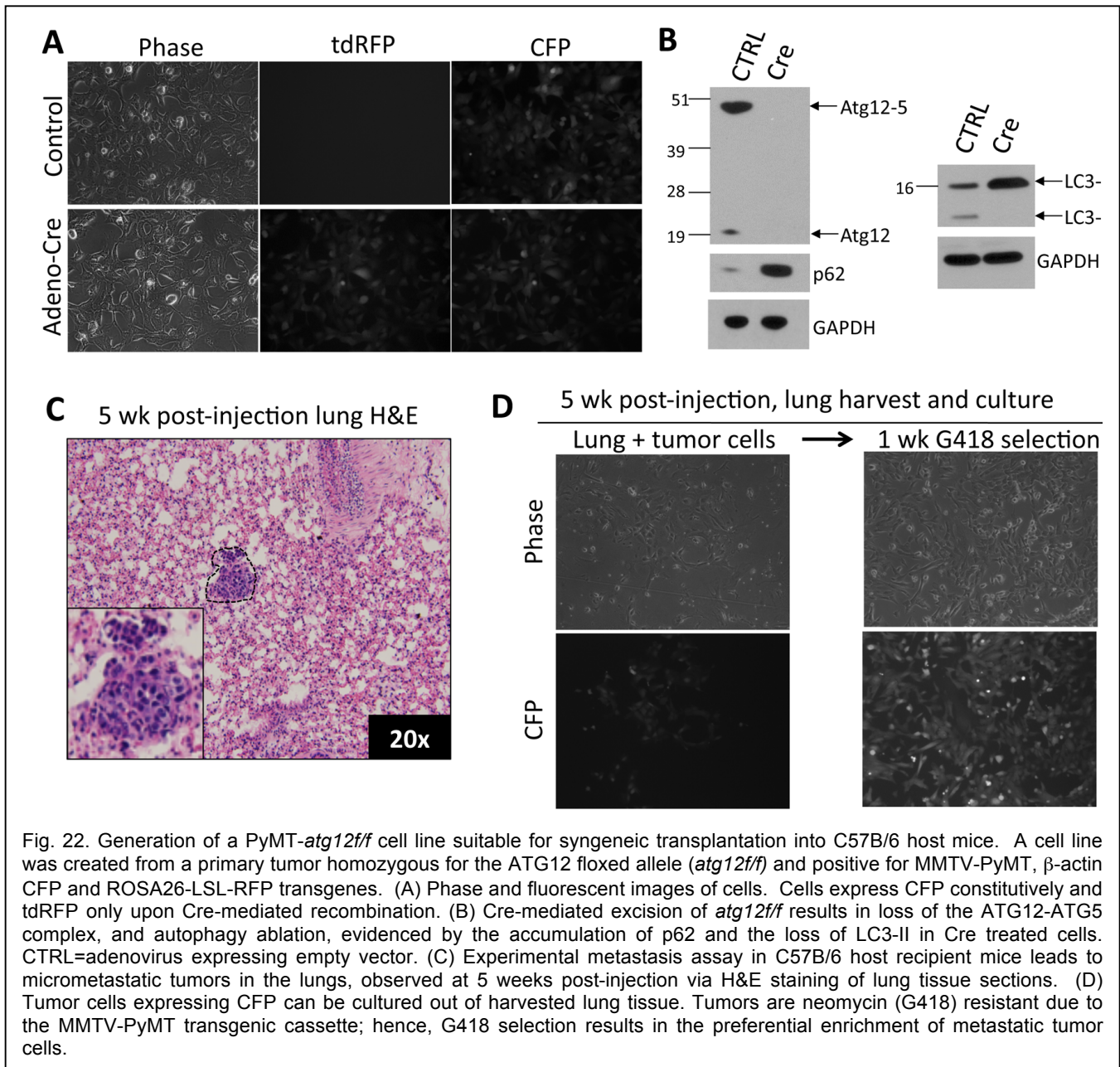

Fig. 22. Generation of a PyMT-*atg12ff* cell line suitable for syngeneic transplantation into C57B/6 host mice. A cell line was created from a primary tumor homozygous for the ATG12 floxed allele (*atg12ff*) and positive for MMTV-PyMT, β -actin CFP and ROSA26-LSL-RFP transgenes. (A) Phase and fluorescent images of cells. Cells express CFP constitutively and tdRFP only upon Cre-mediated recombination. (B) Cre-mediated excision of *atg12ff* results in loss of the ATG12-ATG5 complex, and autophagy ablation, evidenced by the accumulation of p62 and the loss of LC3-II in Cre treated cells. CTRL=adenovirus expressing empty vector. (C) Experimental metastasis assay in C57B/6 host recipient mice leads to micrometastatic tumors in the lungs, observed at 5 weeks post-injection via H&E staining of lung tissue sections. (D) Tumor cells expressing CFP can be cultured out of harvested lung tissue. Tumors are neomycin (G418) resistant due to the MMTV-PyMT transgenic cassette; hence, G418 selection results in the preferential enrichment of metastatic tumor cells.

- c. Determine whether the deletion of autophagy regulators from transplanted neoplastic breast cells affects the onset of metastasis in recipient mice from subtask 2b. Fifteen (15) mice from each cohort will be functionally evaluated for altered characteristics of histopathologic progression from primary to metastatic disease (mammary morphogenesis, epithelial cell proliferation/cell death, overt tumor formation, tumor burden, tumor type, and development/latency to metastases) (Months 25-48).

These studies have been planned for year 3 and 4.

- d. If late onset metastasis does occur in autophagy deficient tumor cell recipients from subtasks 2b-c, isolate late onset macro-metastatic tumors and dormant tumor cells and obtain gene expression profiles. To obtain dormant cells from each cohort in subtask 2b, ten (10) tumor cell bearing mice

from 2b will be euthanized at an intermediate timepoint (anticipated to occur at 6-9 months post fat pad transplantation but prior to overt metastatic disease), cancer cells isolated from host tissues, and if required, expanded ex vivo (Months 37-48).

These studies have not been initiated.

- e. **If metastasis is significantly reduced or eliminated in autophagy deficient tumor cell recipients from subtasks 2b-c, determine the effects of antimalarial treatment on the onset of metastasis in mice transplanted with autophagy competent neoplastic breast cells, using appropriate transplantation models determined from subtask 1d and/or subtask 1i-j (Months 37-60).**

These studies have not been initiated.

Task 3: Determine if dietary restriction or mammalian target of rapamycin (mTOR) inhibition can prevent the expansion of dormant cells into overt metastases.

- a. **Isolate neoplastic epithelium from female transgenic mice generated in subtask 1f, transduce with Cre recombinase, and transplant into cleared mammary fat pads of syngeneic C57B/6 host recipient animals. For this subtask, ten (10) donor mice will be utilized for epithelial isolation. Twenty-five (25) host recipient animals per cohort necessary for subtasks 3b and 3d will be utilized for fat pad transplantation (Months 30-36).**

These studies have not been initiated.

- b. **Determine the effects of dietary restriction (DR), defined as a 40% reduction in caloric intake, on the onset of overt and latent metastasis for recipient mice generated in subtask 3a. We anticipate that twenty-five (25) mice each from two (2) cohorts (cohort 1: subject to DR; cohort 2: controls not subject to DR) will be functionally evaluated for altered characteristics of histopathologic progression from primary to metastatic disease (mammary morphogenesis, epithelial cell proliferation/cell death, overt tumor formation, tumor burden, tumor type, and development/latency to metastases) (Months 37-60).**

These studies have not been initiated.

- c. **From mice in subtask 3b, isolate late onset macro-metastases (if they occur) and dormant tumor cells and obtain gene expression, biosynthetic, and metabolic profiles. To obtain dormant cells from each cohort in subtask 3b, ten (10) tumor cell bearing mice from 3b will be euthanized at an intermediate timepoint (anticipated to occur at 6-9 month post fat pad transplantation but prior to overt metastatic disease), cancer cells isolated from host tissues, and if required, expanded ex vivo (Months 49-60).**

These studies have not been initiated.

- d. **Determine the effects of mTOR inhibition on the onset of overt and latent metastasis for recipient mice generated in subtask 3a. Twenty-five (25) mice per cohort will be functionally evaluated for altered characteristics of histopathologic progression from primary to metastatic disease (mammary morphogenesis, epithelial cell proliferation/cell death, overt tumor formation, tumor burden, tumor type, and development/latency to metastases) (Months 37-60).**

These studies have not been initiated.

- e. **From mice in subtask 3d, isolate late onset macro-metastases (if they occur) and dormant tumor cells and obtain gene expression, biosynthetic, and metabolic profiles. To obtain dormant cells from each cohort in subtask 3b, ten (10) tumor cell bearing mice from 3d will be euthanized at an intermediate timepoint (anticipated to occur at 6-9 month post fat pad transplantation but prior to overt metastatic disease), cancer cells isolated from host tissues, and if required, expanded ex vivo (Months 49-60).**

These studies have not been initiated.

III. KEY RESEARCH ACCOMPLISHMENTS:

Year 1 (Months 1-12):

1. We optimized an overlay ("on-top") three-dimensional organotypic culture system on laminin-rich reconstituted basement membrane suitable for the culture of oncogene-expressing mammary epithelial cells and human breast cancer cells.
2. We uncovered that the anti-malarial chloroquine (CQ) inhibits quiescent behavior in response to mTOR pathway inhibition in mammary epithelial cells expressing a tumor-derived, activating mutation in phosphatidylinositol 3-kinase (PI3K), H1047R. These data support a model that autophagy inhibition may paradoxically promote the active growth of quiescent cells via the MAPK pathway secondary to the accumulation of the autophagy substrate, p62/SQSTM1. **Published in Chen et. al. Oncogene, 2012.**
3. Based on the 3D proliferation rates of 6 human breast cancer cell lines tested during the first year, we identified two ER+ cell lines MCF7 and T47D as lead candidates for further evaluation as potential models for in vivo dormant behavior.
4. We discovered that the antimalarials chloroquine (CQ) and quinacrine (Qu) are able to inhibit the 3D growth and proliferation of MCF7 cells at levels comparable to tamoxifen (OHT).
5. We optimized protocols for the lentiviral-mediated delivery of reporter proteins and the drug resistance markers to breast cancer cells.
6. We optimized protocols for the successful isolation of mammary organoids from normal and PyMT tumor-bearing mice.
7. We developed protocols to deliver adenoviral Cre in order to excise the ATG12 conditional allele (*atg12f/f*) ex vivo from organoids derived from normal mammary gland and PyMT tumors. Upon reintroduction of cells into the mammary fat pads of recipient mice, we confirmed both ATG12 deletion and defective autophagy in the resultant tumors arising from ATG12 deleted tumor cells.
8. We have generated Polyoma Middle T (PyMT), ROSA26-LSL-RFP, and the ATG conditional mouse strains (*atg12f* and *atg5f*) in a pure C57B/6 genetic background.

Year 2 (Months 12-24):

9. We have extended our three-dimensional culture studies of PI3K-H1047R and evaluated the effects of ATG depletion on the morphogenesis of breast epithelial cells transformed with oncogenic Ras. Autophagy inhibition does not impact proliferation in this model, indicating that the effects of autophagy on quiescent behavior in 3D culture are oncogene-dependent.
10. In Ras-transformed breast cancer cells, we have found that the depletion of autophagy-related genes suppresses invasion in three-dimensional culture and reduces pulmonary metastases *in vivo*.
11. Based on conditioned media experiments in 3D culture, we have found that autophagy-deficient Ras cells, fail to secrete pro-invasive factors. We have also discovered that reduced autophagy diminishes the secretion of the pro-migratory cytokine, interleukin-6, which is necessary and sufficient to restore invasion of autophagy-deficient cells. **These findings have been submitted for publication.**
12. We have completed the interbreeding to generate compound transgenic mice containing Polyoma middle T (PyMT), ATG conditional alleles, and ROSA26-LSL-RFP in a C57B/6 genetic background. We

have harvested primary cells from tumor bearing mice, validated the ability to genetically delete ATGs, as well as reintroduce these cells into a syngeneic C57B/6 host.

13. We have confirmed micro-metastatic lesions upon tail vein injection of PyMT cells and the presence of solitary tumor cells within lung tissue of recipient mice at an early time point of a spontaneous metastasis assay, suggesting that this approach will be useful to study recurrence over extended periods of time.
14. We have created a bank of frozen primary PyMT-derived tumor cells in which we can ablate autophagy (via Cre deletion of *atg12* or *atg5*) as well as carry out transplantation studies in the upcoming years.
15. We have created an immortalized cell line from a PyMT *atg12^{ff}* tumor isolated in our laboratory, which will be valuable for dissecting the mechanisms responsible for the phenotypes from experiments using primary tumor-derived tissue in years 3-5.
16. Using stable RNAi-mediated depletion of ATG7 in a PyMT cell line, we have found that autophagy inhibition accelerates the outgrowth of overt metastasis in the lungs of syngeneic recipient mice. We will validate this important result using primary tissue. Overall, this result provides in vivo corroboration for our 3D studies of PI3K-H1047R during year 1 and suggests that increasing autophagy in the host animal may be useful in preventing late recurrent disease. Thus, these data motivates our hypothesis in Task 3 that will be carried out in the upcoming years.

IV. REPORTABLE OUTCOMES:

Publications

Months 1-12 (provided as Appendix material in 2012 Progress Report):

1. **J. Debnath** (2011). The Multifaceted Roles of Autophagy in Breast Cancer. *J. Mamm. Gland Biol. Neopl.* 16 (3): 173-87. PMID: 21779879 PMCID: PMC3170851.
2. N. Chen, Eritja N., Lock R., **Debnath J.** (2012). Autophagy Restricts Proliferation Driven By Oncogenic Phosphatidylinositol 3-Kinase in Three-Dimensional Culture. *Oncogene*. doi: 10.1038/onc.2012.277. 2012 Jul 9. Epub ahead of print. PMID: 22777351 PMCID: PMC3470740.

Months 12-24 (included in Appendix B):

1. Murrow, L, **Debnath, J.** (2013) Autophagy as a Stress Response and Quality Control Mechanism: Implications For Cell Injury and Human Disease. *Annu Rev Pathol.*, 2013, 8:105-137. PMID: 23072311. PMC Record In Progress.
2. M.S. Sosa, P. Bragado, **J. Debnath***, J. A. Aguirre-Ghiso*. Regulation of Tumor Cell Dormancy By Tissue Microenvironments and Autophagy (2013). *Adv. Exp. Med. Biol.*, 734: 73-89. PMID: 23143976. PMC Record In Progress. ***Co-senior author.**
3. N. Chen, **Debnath J.** (2013). I κ B Kinase (IKK) Triggers Detachment-Induced Autophagy In Mammary Epithelial Cells Independently of the PI3K/AKT/MTORC1 Pathway. *Autophagy*. **In press.** PMC Record In Progress.

Presentations (Months 12-24):

International and National Conferences:

2012 Invited Speaker, 6th International Symposium on Autophagy, Okinawa, Japan

- 2012 Invited Speaker, American Society for Cell Biology National Meeting, Minisymposium on Cancer Cell Biology, San Francisco, CA
- 2013 Plenary Speaker, Applied Pharmaceutical Toxicology Meeting, Genentech Inc., South San Francisco, CA

Invited Lectures and Seminars:

- 2012 Invited Speaker, 1st Annual Helen Diller Family Cancer Center Annual Retreat, Santa Cruz, CA
- 2012 Invited Seminar, Department of Physiology, University of Texas Health Science Center, San Antonio, TX
- 2013 Invited Keynote Speaker, 2013 Vancouver Autophagy Symposium, Vancouver, BC, Canada
- 2013 Invited Seminar, Department of Cell and Developmental Biology, Oregon Health & Sciences University, Portland, OR.
- 2013 Invited Seminar, UCSF MSTP Grand Rounds, San Francisco, CA
- 2013 Invited Seminar, Amgen Department of Oncology, San Francisco, CA
- 2013 Invited Seminar, UCSF Breast Oncology Program, San Francisco, CA

Patents and Licenses (Months 1-12):

None.

Degrees Obtained (Months 1-12):

None.

Reagent Development (Months 1-24):

Generation of MMTV-PyMT mice on the C57B/6 strain background.

Generation of *atg12f*, LSL-RFP mice on the C57B/6 strain background.

Generation of *atg5f* mice on the C57B/6 strain background.

Generation of *atg5f*, LSL-RFP mice on the C57B/6 strain background.

Generation of MMTV-PyMT, *atg12f*, LSL-RFP mice on the C57B/6 strain background.

Generation of mammary carcinoma cell line derived from an MMTV-PyMT, *atg12f*, β -actin CFP, ROSA26-LSL-RFP host tumor suitable for transplantation into C57B/6 syngeneic host animals.

Funding Applied For Based On Work Supported By Era of Hope (Months 12-24):

1. Rudnick, Jenny (Post-doc): ACS Post-doctoral Fellowship
Status: AWARDED (7/1/2013 – 9/14/16)
3 year ACS award was terminated early to start DOD fellowship.
2. Rudnick, Jenny (Post-doc): BC123093 (DOD BCRP Post-doctoral Fellowship)
Status: AWARDED (9/15/13 -9/14/16)
3. Debnath, Jayanta (PI): UCSF Breast Oncology Program Developmental Project
Status: AWARDED (4/1/2013 - 3/31/2013)
4. Debnath, Jayanta (PI): Samuel Waxman Cancer Research Foundation Award
Status: AWARDED (8/1/2013-7/30/2015)

Employment and Research Opportunities:

None.

V. CONCLUSION:

The biological processes that govern the critical steps in late recurrent disease in breast cancer remain largely unclear[2]. This project focuses on how the fundamental stress pathway autophagy impact quiescent versus proliferative behavior exhibited by breast cancer cells. To meet this objective, we have created new three-dimensional organotypic culture models to assess quiescent behavior displayed by breast cancer cells as well as in vivo mouse models to recapitulate late recurrent breast cancer.

Our studies using a three-dimensional organotypic culture model to investigate oncogene-expressing mammary epithelial cells and human breast cancer cells have uncovered two opposing, context-dependent functions for autophagy that will potentially impact late recurrent metastatic progression. On the one hand, in breast tumors driven by the PI3K pathway, autophagy restricts proliferation and maintains a quiescent state. On the other, in tumors with hyper-activation of the Ras/MAPK pathway, autophagy promotes invasive behavior and alters epithelial differentiation and secretion. For our ongoing and planned in vivo studies, we will place high priority on elaborating whether and how these two biological functions for the autophagy pathway impact disease progression. Furthermore, using PyMT mouse tumor cell lines transplanted into syngeneic immunocompetent hosts, we have obtained evidence that autophagy inhibition promotes, rather than impedes the metastasis of PyMT cells in vivo. Importantly, the PyMT oncogene strongly activates the PI3K/AKT pathway in breast cancer cells, and our initial in vivo findings are consistent with our 3D studies of oncogenic PI3K that show the enhanced proliferation of quiescent cells. At the same time, the enhanced metastatic outgrowth may partly arise from altered differentiation, as we observed upon autophagy inhibition in the context of Ras/MAPK pathway activation, because the process of mesenchymal-to-epithelial transition has been implicated in metastatic outgrowth [25]. We will further interrogate these mechanistic possibilities. Regardless of the mechanisms involved, these findings have unexpected implications for autophagy in late recurrent disease by modulating the exit of dormant tumor cells from quiescent states to produce overt metastatic disease. We will further corroborate this hypothesis in the upcoming years using the primary in vivo models that we have developed.

Ultimately, the major barrier for elucidating what biological processes modulate late recurrent breast cancer is a lack of in vivo models. To address this critical gap in the field, we are utilizing the MMTV-PyMT model, a well-established transgenic model of breast cancer progression and metastatic disease. Because PyMT mice derived in a pure C57B/6 strain exhibit reduced rates of primary tumor formation and subsequent metastases [26], we will exploit the delayed kinetics of PyMT tumor progression in C57B/6 mice to more effectively model late recurrence and assess the effects of autophagy on dormant tumor cell behavior. Over the past year, we have completed the creation of compound transgenic mice containing MMTV-PyMT and ATG conditional alleles on the C57B/6 strain background; we have isolated tumors from these animals and confirmed that autophagy can be conditionally ablated ex vivo or in vivo. Our studies in the upcoming years require the ex vivo genetic manipulation of tumors followed by transplantation into the mammary fat pad transplantation of syngeneic recipient mice. Accordingly, we have confirmed the presence of micro-metastatic lesions upon tail vein injection of PyMT cells and the presence of solitary tumor cells within lung tissue of recipient mice at an early time point of a spontaneous metastasis assay, suggesting that this approach will be useful to study recurrence and metastasis over extended periods of time. Finally, for our transplantation studies in the upcoming years, we have created a bank of frozen primary PyMT-derived tumor cells in which we can ablate autophagy as well as developed an immortalized cell line from a PyMT *atg12f/f* tumor that will be invaluable for dissecting the mechanisms underlying the phenotypes we observe using primary tumor-derived tissue.

Impact: Late recurrent breast cancer is highly resistant to available treatments and commonly metastatic; hence, it is a principal cause of lethality in breast cancer patients. By generating robust in vivo systems for late recurrent disease, we will address an essential unmet need in breast cancer research. To eliminate late recurrent breast cancer, one potential strategy may be to impede their ability to “reawaken” and develop into lethal macro-metastases by promoting autophagy. Moreover, if we validate a functional requirement for

autophagy in the mediating outgrowth of quiescent cells during late recurrent disease, we hope to modulate this fundamental process using strategies, such as dietary restriction, for therapeutic benefit.

VI: BIBLIOGRAPHY:

1. Aguirre-Ghiso JA: **Models, mechanisms and clinical evidence for cancer dormancy.** *Nat Rev Cancer* 2007, **7**:834-846.
2. Debnath J: **The multifaceted roles of autophagy in tumors-implications for breast cancer.** *J Mammary Gland Biol Neoplasia* 2011, **16**:173-187.
3. Sosa MS, Bragado P, Debnath J, Aguirre-Ghiso JA: **Regulation of tumor cell dormancy by tissue microenvironments and autophagy.** *Adv Exp Med Biol* 2013, **734**:73-89.
4. Chen N, Eritja N, Lock R, Debnath J: **Autophagy restricts proliferation driven by oncogenic phosphatidylinositol 3-kinase in three-dimensional culture.** *Oncogene* 2012.
5. Neve RM, Chin K, Fridlyand J, Yeh J, Baehner FL, Fevr T, Clark L, Bayani N, Coppe JP, Tong F, et al.: **A collection of breast cancer cell lines for the study of functionally distinct cancer subtypes.** *Cancer Cell* 2006, **10**:515-527.
6. Guo JY, Chen HY, Mathew R, Fan J, Strohecker AM, Karsli-Uzunbas G, Kamphorst JJ, Chen G, Lemons JM, Karantza V, et al.: **Activated Ras requires autophagy to maintain oxidative metabolism and tumorigenesis.** *Genes Dev* 2011, **25**:460-470.
7. Guo JY, Karsli-Uzunbas G, Mathew R, Aisner SC, Kamphorst JJ, Strohecker AM, Chen G, Price S, Lu W, Teng X, et al.: **Autophagy suppresses progression of K-ras-induced lung tumors to oncocytomas and maintains lipid homeostasis.** *Genes Dev* 2013, **27**:1447-1461.
8. Kim MJ, Woo SJ, Yoon CH, Lee JS, An S, Choi YH, Hwang SG, Yoon G, Lee SJ: **Involvement of autophagy in oncogenic K-Ras-induced malignant cell transformation.** *J Biol Chem* 2011, **286**:12924-12932.
9. Lock R, Roy S, Kenific CM, Su JS, Salas E, Ronen SM, Debnath J: **Autophagy facilitates glycolysis during Ras-mediated oncogenic transformation.** *Mol Biol Cell* 2011, **22**:165-178.
10. Yang S, Wang X, Contino G, Liesa M, Sahin E, Ying H, Bause A, Li Y, Stommel JM, Dell'antonio G, et al.: **Pancreatic cancers require autophagy for tumor growth.** *Genes Dev* 2011, **25**:717-729.
11. Fung C, Lock R, Gao S, Salas E, Debnath J: **Induction of Autophagy during Extracellular Matrix Detachment Promotes Cell Survival.** *Mol Biol Cell* 2008, **19**:797-806.
12. Debnath J, Brugge JS: **Modelling glandular epithelial cancers in three-dimensional cultures.** *Nat Rev Cancer* 2005, **5**:675-688.
13. Debnath J, Mills KR, Collins NL, Reginato MJ, Muthuswamy SK, Brugge JS: **The role of apoptosis in creating and maintaining luminal space within normal and oncogene-expressing mammary acini.** *Cell* 2002, **111**:29-40.
14. Thiery JP: **Epithelial-mesenchymal transitions in development and pathologies.** *Curr Opin Cell Biol* 2003, **15**:740-746.
15. Shin S, Dimitri CA, Yoon SO, Dowdle W, Blenis J: **ERK2 but not ERK1 induces epithelial-to-mesenchymal transformation via DEF motif-dependent signaling events.** *Mol Cell* 2010, **38**:114-127.
16. Polyak K, Weinberg RA: **Transitions between epithelial and mesenchymal states: acquisition of malignant and stem cell traits.** *Nat Rev Cancer* 2009, **9**:265-273.
17. Xu J, Lamouille S, Derynck R: **TGF-beta-induced epithelial to mesenchymal transition.** *Cell Res* 2009, **19**:156-172.
18. Scheel C, Eaton EN, Li SH, Chaffer CL, Reinhardt F, Kah KJ, Bell G, Guo W, Rubin J, Richardson AL, et al.: **Paracrine and autocrine signals induce and maintain mesenchymal and stem cell States in the breast.** *Cell* 2011, **145**:926-940.
19. Friedl P, Wolf K: **Tumour-cell invasion and migration: diversity and escape mechanisms.** *Nat Rev Cancer* 2003, **3**:362-374.
20. Young AR, Narita M, Ferreira M, Kirschner K, Sadaie M, Darot JF, Tavares S, Arakawa S, Shimizu S, Watt FM, et al.: **Autophagy mediates the mitotic senescence transition.** *Genes Dev* 2009, **23**:798-803.

21. Ancrile B, Lim KH, Counter CM: **Oncogenic Ras-induced secretion of IL6 is required for tumorigenesis.** *Genes Dev* 2007, **21**:1714-1719.
22. Leslie K, Gao SP, Berishaj M, Podsypanina K, Ho H, Ivashkiv L, Bromberg J: **Differential interleukin-6/Stat3 signaling as a function of cellular context mediates Ras-induced transformation.** *Breast Cancer Res* 2010, **12**:R80.
23. Sullivan NJ, Sasser AK, Axel AE, Vesuna F, Raman V, Ramirez N, Oberyshyn TM, Hall BM: **Interleukin-6 induces an epithelial-mesenchymal transition phenotype in human breast cancer cells.** *Oncogene* 2009, **28**:2940-2947.
24. Narita M, Young AR, Arakawa S, Samarajiwa SA, Nakashima T, Yoshida S, Hong S, Berry LS, Reichelt S, Ferreira M, et al.: **Spatial coupling of mTOR and autophagy augments secretory phenotypes.** *Science* 2011, **332**:966-970.
25. Tsai JH, Donaher JL, Murphy DA, Chau S, Yang J: **Spatiotemporal regulation of epithelial-mesenchymal transition is essential for squamous cell carcinoma metastasis.** *Cancer Cell* 2012, **22**:725-736.
26. Lifsted T, Le Voyer T, Williams M, Muller W, Klein-Szanto A, Buetow KH, Hunter KW: **Identification of inbred mouse strains harboring genetic modifiers of mammary tumor age of onset and metastatic progression.** *Int J Cancer* 1998, **77**:640-644.

VII: APPENDICES:

- A. Curriculum Vitae of Jayanta Debnath.
- B. Collected publications from Months 12-24.

Autophagy as a Stress-Response and Quality-Control Mechanism: Implications for Cell Injury and Human Disease

Lyndsay Murrow and Jayanta Debnath

Department of Pathology, Helen Diller Family Comprehensive Cancer Center, and Biomedical Sciences Graduate Program, University of California, San Francisco, California 94143; email: Lyndsay.Murrow@ucsf.edu, Jayanta.Debnath@ucsf.edu

Annu. Rev. Pathol. Mech. Dis. 2013. 8:105–37

First published online as a Review in Advance on October 31, 2012

The *Annual Review of Pathology: Mechanisms of Disease* is online at pathol.annualreviews.org

This article's doi:
10.1146/annurev-pathol-020712-163918

Copyright © 2013 by Annual Reviews.
All rights reserved

Keywords

macroautophagy, lysosome, mitophagy, inflammation, neurodegeneration, myopathy

Abstract

Autophagy, a vital catabolic process that degrades cytoplasmic components within the lysosome, is an essential cytoprotective response to pathologic stresses that occur during diseases such as cancer, ischemia, and infection. In addition to its role as a stress-response pathway, autophagy plays an essential quality-control function in the cell by promoting basal turnover of long-lived proteins and organelles, as well as by selectively degrading damaged cellular components. This homeostatic function protects against a wide variety of diseases, including neurodegeneration, myopathy, liver disease, and diabetes. This review discusses our current understanding of these two principal functions of autophagy and describes in detail how alterations in autophagy promote human disease.

Macroautophagy: catabolic pathway involving (a) sequestration of cytoplasmic components into a double-membrane structure known as the autophagosome and (b) subsequent lysosomal degradation

AP: autophagosome

ATG: autophagy gene

INTRODUCTION

Autophagy (literally self-eating) is an essential catabolic pathway that degrades cellular components within the lysosome. There are three principal routes of autophagic degradation, which differ mainly in the means of cargo delivery to the lysosome: macroautophagy, microautophagy, and chaperone-mediated autophagy (CMA) (1). During macroautophagy, bulk cytoplasmic components are sequestered in a double-membrane structure known as the autophagosome (AP); the AP is subsequently trafficked to the lysosome. Its outer membrane then fuses to the lysosome, leading to degradation of its contents. In microautophagy and CMA, cargo is directly taken up by the lysosome, either through invagination of the lysosomal membrane (in microautophagy) or by unfolding and translocation of proteins with a specific signal sequence that (in CMA) is recognized by the LAMP2A receptor on the lysosome (1). This review focuses on macroautophagy, hereafter referred to as autophagy.

Autophagy was first identified in mammalian cells by electron microscopy studies in the 1960s, but an understanding of the molecular pathways involved was not achieved until almost 30 years later, following the discovery of the first autophagy genes (ATGs) through landmark genetic screens in yeast. These initial experiments identified a set of highly conserved ATGs that control autophagy (2), many of which have mammalian orthologs. Further studies have elucidated the molecular pathways that control autophagy in mammalian systems (**Figure 1**) and have revealed

the importance of autophagy in both normal physiology and disease (1). The identification of yeast ATGs and their mammalian homologs has also enabled experimental manipulation of the autophagy pathway and the development of assays for monitoring autophagic activity and flux (**Figure 2**) (3).

Autophagy machinery components are mutated in various human diseases, which underscores the importance of autophagy in human health (**Table 1**). Tissue-specific deletion of ATGs and autophagy-related genes in mice has also provided further insight into the role of autophagy in maintaining normal tissue homeostasis and in disease pathogenesis (**Table 2**). In this review, we discuss the role of autophagy in the cellular stress response and in cellular homeostasis and describe how alterations in autophagy promote disease pathogenesis.

AUTOPHAGY IN STRESS RESPONSE

Autophagy is an essential prosurvival pathway induced by a wide variety of stresses, including nutrient deprivation, growth factor withdrawal, oxidative stress, infection, and hypoxia (4). During periods of stress, autophagy maintains cellular biosynthetic capacity and ATP levels by supplying amino acids for de novo protein synthesis and providing substrates for the tricarboxylic acid (TCA) cycle, such as amino acids and free fatty acids (5). In mice, autophagy is upregulated in almost all tissues, except the brain, following starvation (6). Mice lacking the essential ATGs *Atg5* or *Atg7* (**Figure 1b**)

Figure 1

Overview of the mammalian autophagy machinery. Autophagy occurs in a series of distinct stages: (i) initiation of the isolation membrane (IM), also known as the phagophore assembly site (PAS); (ii) cargo recognition; (iii) elongation; (iv) enclosure of the double-membrane structure to form the autophagosome (AP); and (v) maturation/degradation, in which the AP fuses to the lysosome to form an autolysosome (AL), wherein its contents are degraded. The effects of autophagy inhibitors 3-methyladenine (3-MA) and chloroquine (CQ), along with the autophagy inducer rapamycin (Rap), are shown. (a) The Ulk and class III phosphatidylinositol 3-kinase (PI3K) complexes are necessary for autophagy initiation. Beclin 1 forms two distinct autophagy-promoting complexes with the PI3K Vps34. (b) The ubiquitin-like conjugation machinery attaches Atg12 to Atg5 and LC3 to the lipid phosphatidylethanolamine (PE); this machinery mediates AP elongation. Loss of any of these core components (e.g., Beclin 1 or Atg5) leads to autophagy deficiency. (c) In addition to its role in autophagy induction, Beclin 1 also promotes autophagic maturation via interactions with Rubicon.

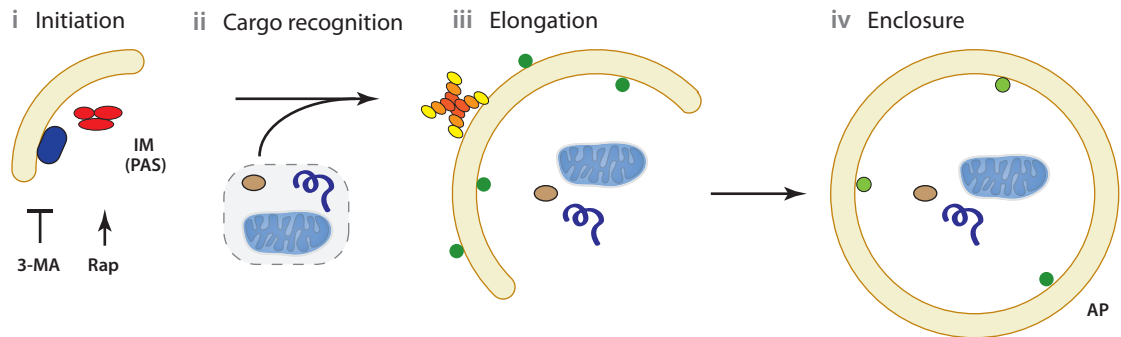

a Initiation: Ulk and class III PI3K complexes

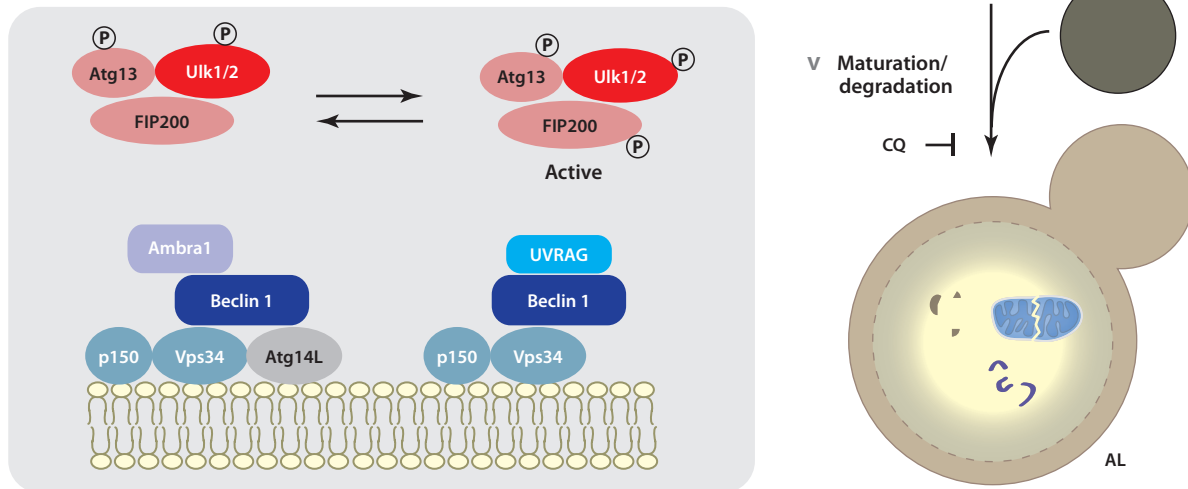

b Elongation: ubiquitin-like conjugation machinery

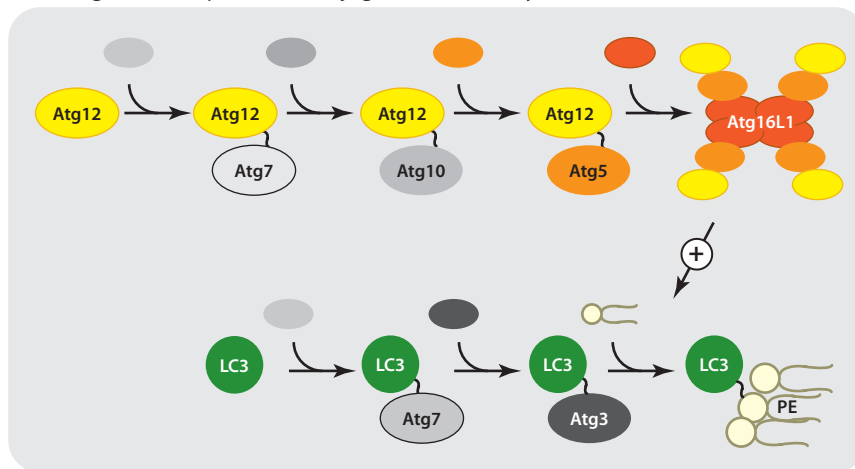

c Maturation

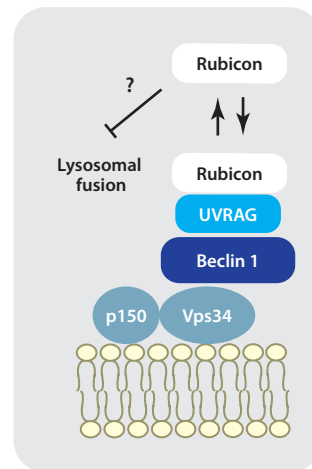

have decreased plasma and tissue amino acid concentrations and die within one day of birth, which may be due to nutrient depletion during the neonatal starvation period (7, 8). **Figure 1** details the molecular functions of ATGs discussed throughout this review.

The importance of autophagy as a pro-survival catabolic pathway has also been demonstrated in cell culture systems. In Bax/Bak double-knockout cells, which are unable to undergo apoptosis, intact autophagy protects cells from death following prolonged growth

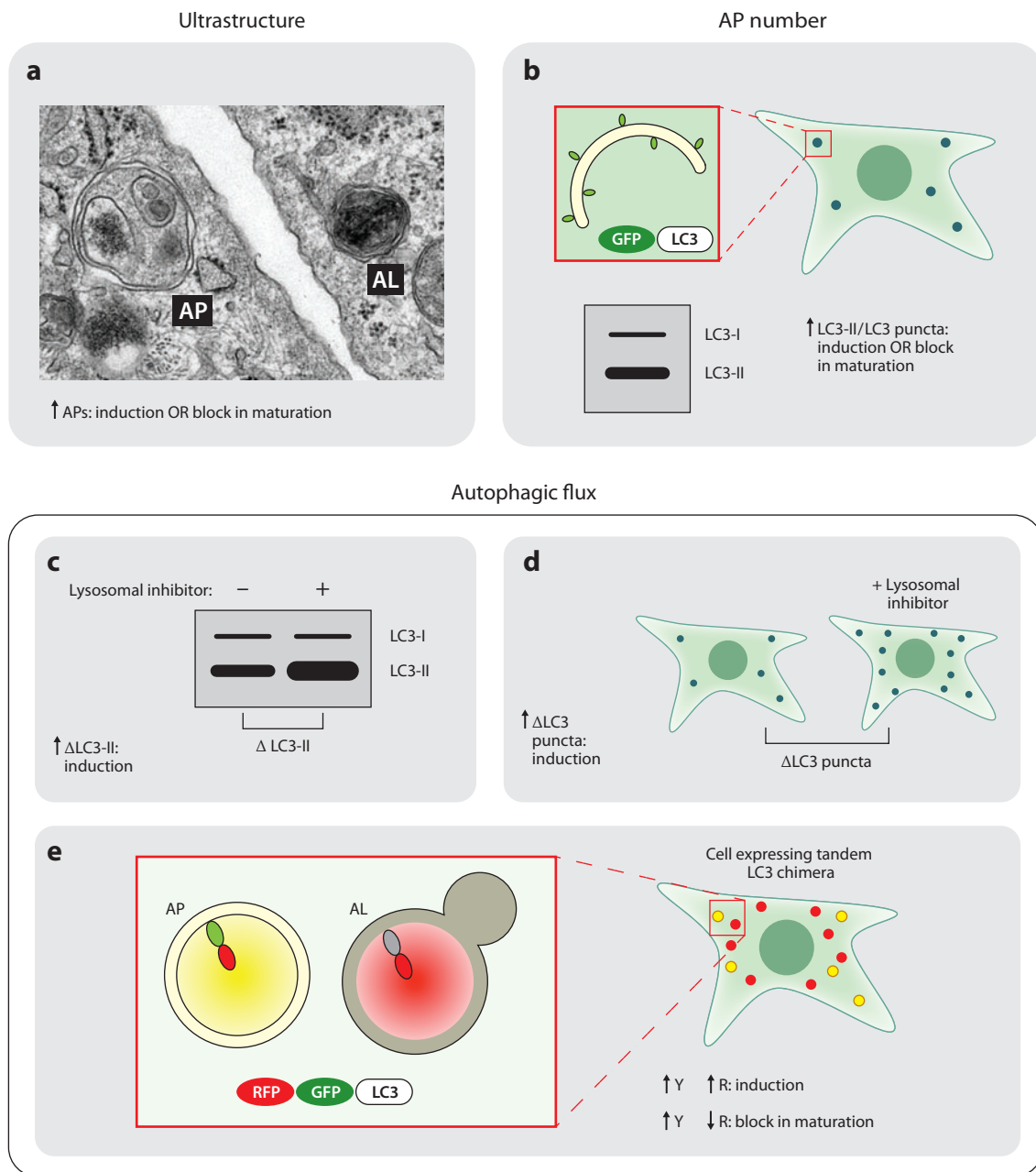

Table 1 Human disease mutations that affect autophagy

Gene	Function in autophagy	Disease	Probable disease defect	Reference
Core autophagy component				
<i>Atg16L1</i>	Core autophagy component, essential for autophagosome elongation	Crohn's disease	Defect in bacterial clearance, increased proinflammatory cytokine secretion	57
Autophagy induction/initiation				
<i>IRGM</i>	Autophagy induction in response to IFN- γ	Crohn's disease	Defect in bacterial clearance, abnormal lymphocytes and macrophages	57
<i>Jumpy (MTMR14)</i>	PI3P phosphatase, negative regulator of autophagy induction	Centronuclear myopathy	Overactive autophagy	133
Cargo recognition/AP targeting				
<i>NOD2</i>	Autophagy induction in response to MDP, targeting of <i>Atg16L1</i> to bacteria	Crohn's disease	Defect in bacterial clearance, increased proinflammatory cytokine secretion	57
<i>PINK1</i>	Mitophagy	PD	Defect in mitochondrial clearance, accumulation of damaged mitochondria	102
<i>Parkin</i>	Mitophagy	PD	Defect in mitochondrial clearance, accumulation of damaged mitochondria	101
Lysosome function				
Presenilin 1	Targeting of v-ATPase V0a1 to the lysosome	AD	Defect in lysosomal acidification, accumulation of protein aggregates	114
Lysosomal α -glucosidase	Glycogen breakdown in the lysosome	Pompe disease ^a	Lysosomal glycogen accumulation, defect in AP-lysosome fusion	72
<i>LAMP2B</i>	Maintenance of lysosome function	Danon disease ^b	Defect in AP-lysosome fusion	131

^aGlycogen storage disorder, characterized by muscle atrophy and cardiomyopathy.

^bX-linked hereditary disorder, characterized by cardiomyopathy and myopathy. Abbreviations: AD, Alzheimer's disease; AP, autophagosome; IFN, interferon; MDP, muramyl dipeptide; PD, Parkinson's disease; PI3P, phosphatidylinositol 3-phosphate.

factor withdrawal. In growth factor-deprived cells, RNA interference (RNAi)-mediated Atg7 depletion or treatment with the autophagy inhibitors 3-methyladenine (3-MA) or chloroquine (CQ) (**Figure 1**) leads to cell death.

Supplying autophagy-deficient cells with the TCA cycle substrate methylpyruvate rescues ATP production and cell viability (9), which demonstrates that the catabolic function of autophagy probably mediates cytoprotection.

3-MA:
3-methyladenine

Figure 2

Methods for monitoring autophagy. Early studies implicating autophagy in disease measured primarily the total number of autophagosomes (APs), either (a) by identification of APs and autolysosomes (ALs) by electron microscopy or (b) by measurement of the total levels of lipidated LC3 (LC3-II) or the number of LC3 puncta (which mark APs) in cells expressing green fluorescent protein (GFP)-tagged LC3 (GFP-LC3). Importantly, in both cases, an increase in APs can indicate either autophagy induction or a block in AP maturation. Autophagic flux assays more directly measure total autophagic activity. In the presence of lysosomal inhibitors, (c) increased accumulation of lipidated LC3 or (d) increased accumulation of GFP-LC3 puncta indicates autophagic induction. (e) In cells expressing tandem red fluorescent protein (RFP)-GFP-tagged LC3, APs are identified as yellow (Y) puncta and ALs as red (R) puncta following quenching of GFP fluorescence in the lysosome. An increase in both signals indicates autophagy induction, whereas an increase in Y with a decrease in R indicates a block in maturation. Abbreviations: Δ LC3 puncta, accumulation of GFP-LC3 puncta; LC3-I, nonlipidated LC3; Δ LC3-II, accumulation of lipidated LC3.

Table 2 Disruption of autophagy in mouse models of disease

Genotype	Tissue	Phenotype	Reference(s)
<i>Beclin1</i> ^{+/-}	All	Decreased infarct size during cardiac I/R	22
<i>Atg5</i> ^{f/f} : <i>MerCreMer</i> ^a	Cardiomyocytes	In adult mice: hypertrophy, contractile dysfunction, and accumulation of ubiquitinated proteins	71
<i>Atg5</i> ^{-/-}	Thymus (transplant)	Altered T cell selection and multiorgan inflammation	50
<i>2Atg5</i> ^{f/f} : <i>villin-Cre</i>	Intestinal epithelium	Paneth cell and granule secretion defects	55
<i>Atg7</i> ^{f/f} : <i>villin-Cre</i>	Intestinal epithelium	Paneth cell and granule secretion defects	66
<i>Atg16L1</i> ^{HM}	Intestinal epithelium	Paneth cell and granule secretion defects, increased susceptibility to DSS-induced colitis	55, 59
<i>Atg5</i> ^{f/f} : <i>nestin-Cre</i>	Neurons	Neurodegeneration and motor defects, accumulation of protein aggregates and inclusions	73
<i>Atg7</i> ^{f/f} : <i>nestin-Cre</i>	Neurons	Neurodegeneration and motor defects, accumulation of protein aggregates and inclusions	74
<i>Becn1</i> ^{+/-} <i>APP</i> ^b	All	Increased APP/A β aggregation, severe neurodegeneration	118, 119
<i>Parkin</i> ^{-/-}	All	Mitochondrial defects, no neurodegeneration	108
<i>Pink1</i> ^{-/-}	All	Age-dependent mitochondrial defects and loss of spontaneous motor activity, no neurodegeneration	109
<i>Slc6a3-Parkin-Q311X</i> ^c	Dopaminergic neurons	Progressive motor defects, substantia nigra degeneration, α -synuclein accumulation	110
<i>Atg5</i> ^{f/f} : <i>HSA-Cre</i>	Muscle	Accumulation of abnormal mitochondria and protein aggregates and inclusions	72
<i>Atg5</i> ^{f/f} : <i>HSA-Cre</i> GAA KO ^d	Muscle	Severe muscle atrophy, accumulation of abnormal mitochondria and protein aggregates and inclusions	72
<i>Atg7</i> ^{f/f} : <i>MLC1f-Cre</i>	Muscle	Muscle atrophy, accumulation of abnormal mitochondria and protein aggregates and inclusions	70
<i>Atg7</i> ^{f/f} : <i>MX1-Cre</i>	Liver	Hepatomegaly; accumulation of abnormal membranous structures, mitochondria, peroxisomes, and protein inclusions	8
<i>Atg7</i> ^{f/f} : <i>Alb-Cre</i>	Liver	Increased TG and cholesterol levels, increased TG accumulation following starvation	134
<i>Atg7</i> ^{f/f} : <i>RIP-Cre</i>	β cells	β cell degeneration, loss of insulin production, accumulation of damaged mitochondria and protein aggregates	68, 69

^aTamoxifen inducible, cardiomyocyte specific.

^bTransgenic overexpression of human amyloid precursor protein (APP).

^cTransgenic overexpression of C-terminal truncated human Parkin.

^dLysosomal α -glucosidase knockout, a mouse model of Pompe disease. Abbreviations: A β , amyloid β ; DSS, dextran sulfate sodium; I/R, ischemia-reperfusion; TG, triglyceride.

mTOR: mammalian target of rapamycin

Importantly, self-eating does not protect a cell indefinitely; rather, autophagy is proposed to function as a battery that buys cells time, allowing them to survive if the stress is resolved in a timely manner. In this context, autophagy is considered a salvage mechanism that provides

basic components to sustain core metabolic functions during starvation or stress (10).

Stress-induced autophagy is controlled primarily at two critical nodes: mammalian target of rapamycin (mTOR) and AMP-activated protein kinase (AMPK). TOR was

initially identified as a negative regulator of autophagy in yeast and has been corroborated as a major regulator of mammalian autophagy (4). In mammalian cells, under normal nutrient conditions active mTOR phosphorylates Ulk1 (the mammalian Atg1 ortholog) and sequesters it in a complex with Atg13 and FIP200, thereby inhibiting autophagy (11–13). Starvation, amino acid deprivation, or growth factor withdrawal inhibits mTOR activity, which leads to autophagy induction (**Figure 3a**) (14). AMPK is a major positive regulator of autophagy that is activated by a high ratio of AMP to ATP (4). Under conditions of low intracellular energy, activated AMPK induces autophagy both by phosphorylating Ulk1, thereby activating it, and by inhibiting mTOR complex 1 (mTORC1) via phosphorylation of Raptor (**Figure 3a**) (11, 15). Both AMPK and mTOR also control cell growth and metabolism, coupling autophagy to these processes.

Other important stress-response pathways that induce autophagy include hypoxia-inducible factor 1 (HIF-1) signaling in response to hypoxia, p53 signaling downstream of DNA damage, and pattern recognition receptor (PRR) signaling following infection (4). The transcription factor HIF-1 is stabilized under hypoxic conditions, leading to induction of a hypoxia-associated gene expression pattern. The BH3-only protein BNIP3 is a major HIF-1 target, and it is essential for autophagy induction following hypoxia. BNIP3 induces autophagy by binding to Bcl-2 and consequently disrupting the inhibitory interaction between Bcl-2 and Beclin 1 (the mammalian ortholog of yeast Atg6) (**Figure 3b**) (16). The tumor suppressor p53 is induced by various cellular stresses, including DNA damage, and plays dual roles in autophagy induction. Multiple transcriptional targets of p53 activate autophagy, including BAX and PUMA. However, cytosolic p53 also has transcription-independent functions, and cytosolic p53 inhibits autophagy (4). The consequences of this balance between the pro- and anti-autophagic roles of p53 are not well understood. Finally, PRRs recognize molecular patterns

associated with different pathogens and induce autophagy following infection (**Figure 3c**) (17). The signaling pathways leading from PRR activation to autophagy induction remain unclear, but there is evidence that AMPK and Beclin 1 function as downstream effectors in some contexts (18, 19). The induction of autophagy via PRRs is discussed in greater detail below.

AUTOPHAGY ACTIVATION IN RESPONSE TO DISEASE-RELATED CELL STRESS

Given the central role that autophagy plays in responding to cellular stresses, it is not surprising that autophagy is an essential response to disease-induced stress. Autophagy generally plays a prosurvival role during disease, although there are also contexts in which either overactive autophagy or autophagy induction coupled to lysosomal or maturation defects may be cytotoxic, as discussed below. Stresses such as starvation, hypoxia, and oxidative or genotoxic stress contribute to the etiology of multiple diseases including cancer, stroke, heart disease, and infection. Notably, growing evidence supports key roles for autophagy during cancer progression and metastasis. As a result, there is immense interest in discerning how to most effectively modulate autophagy to treat cancer. Accordingly, the multifaceted roles of autophagy in cancer progression and response to therapy have recently been covered in multiple excellent reviews (10, 20). Below, we focus on three specific examples that poignantly illustrate the diverse roles of autophagy as a response to disease-induced cell stress: (a) cardiac ischemia/reperfusion (I/R) injury, (b) infection, and (c) chronic inflammation during Crohn's disease.

Role of Autophagy During Cardiac Ischemia/Reperfusion Injury

Cardiac I/R injury results from a blockage in blood supply to the heart. It is characterized by two phases: ischemia, during which impaired coronary circulation leads to a state of nutrient

Pattern recognition receptor (PRR): receptor activated by pathogen-specific molecules or damage signals following infection

I/R: ischemia/reperfusion

and oxygen deprivation, and reperfusion, during which circulation is restored. The primary tissue damage occurs during the reperfusion phase (21).

Autophagy induction during ischemia may be a response to nutrient withdrawal and

subsequent energy depletion caused by impaired blood supply. Given that starvation is a classical inducer of autophagy, it is not surprising that autophagy plays an important role in the response to the starved state during I/R. Moreover, HIF-1 signaling and BNIP3

a mTOR and AMPK

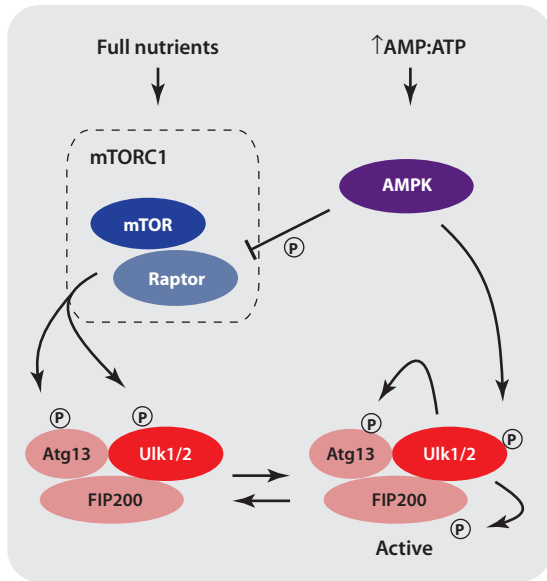

b HIF-1 (BNIP3)

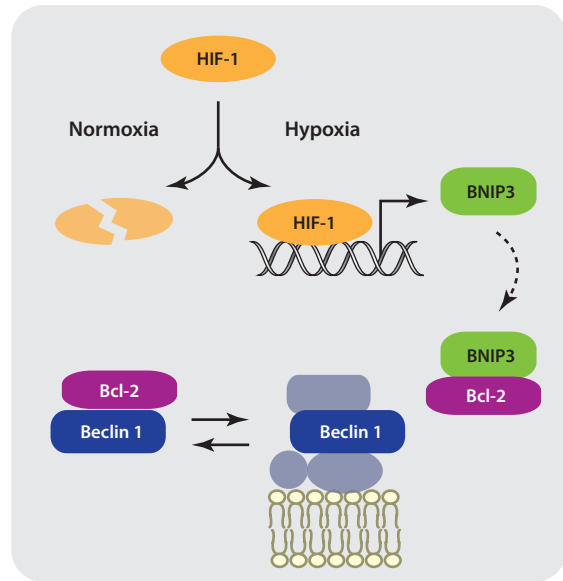

c TLRs

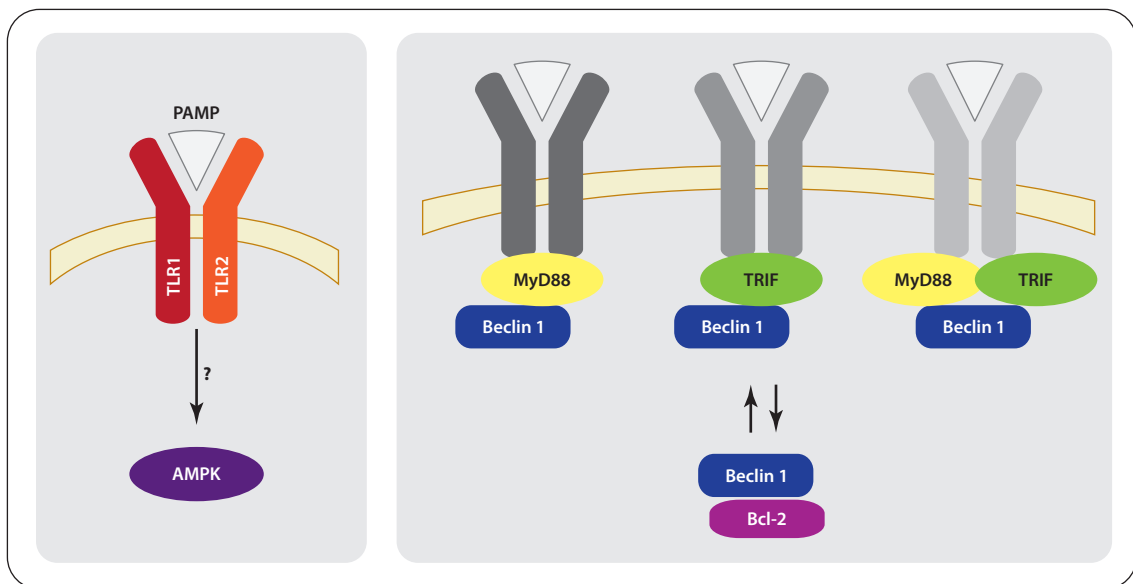

upregulation following hypoxia may also induce autophagy following ischemia (**Figure 3b**), although the relative role of this pathway in cardiac ischemia is unknown (16). Autophagy during the ischemic phase is thought to be cytoprotective because it can supply amino acids for use in the TCA cycle to maintain cellular ATP levels. Autophagy may also protect against oxidative damage during ischemia by supplying amino acids for glutathione synthesis (21). By using glucose deprivation in primary cultured myocytes as an *in vitro* model of ischemia, Matsui et al. (22) demonstrated that autophagy induction following ischemia is AMPK dependent (**Figure 3a**). Inhibiting AMPK or inhibiting AP formation with 3-MA during glucose deprivation severely depletes cellular ATP and reduces cell viability. In a further confirmation of this result *in vivo*, transgenic mice with cardiac-specific expression of a dominant negative AMPK have reduced autophagy induction during ischemia and increased infarct size (23). Although these data suggest that autophagy is upregulated following ischemia and that it plays a cytoprotective role, there may be certain pathological contexts in which an ischemic cell is unable to induce autophagy. In the cardiomyocyte tumor line HL-1, although autophagy is induced by glucose deprivation alone, AP formation is severely impaired upon combining glucose deprivation with hypoxia (24). Autophagy induction may depend on the degree of energy depletion following prolonged or severe ischemia, given that autophagy is an ATP-dependent process (21).

AP accumulation is further increased during the reperfusion phase (22). However, this accumulation may be due to decreased AP turnover rather than increased induction, given that I/R leads to a profound impairment in autophagic flux as measured by buildup of green fluorescent protein (GFP)-LC3 puncta following treatment with lysosomal inhibitors (**Figure 2d**) (24). The precise role of autophagy during reperfusion remains somewhat controversial. Beclin 1 is upregulated during reperfusion, and overexpression of Beclin 1 enhances autophagic flux in an *in vitro* model of I/R, which is cytoprotective (22, 24). However, inhibiting autophagy by treatment with 3-MA or Beclin 1 knockdown also increases cell viability in an *in vitro* model of I/R (22, 25), and *Beclin1* heterozygous mice have decreased infarct size following I/R (**Table 2**) (22). These conflicting data may be attributed to the dual roles of Beclin 1 in regulating both AP formation and autophagic flux. Beclin 1 is an essential component of the phosphatidylinositol 3-kinase (PI3K) complex that mediates AP initiation (**Figure 1a**); at the same time, Beclin 1 promotes autophagic flux via interactions with Rubicon, although the precise mechanism for this process is unclear (**Figure 1c**) (26, 27). This observation suggests a model in which autophagy is cytoprotective during I/R, but the severe block in autophagic flux following reperfusion is cytotoxic; this block in AP maturation leads to the accumulation of APs, expansion of the lysosomal compartment, and eventual leakage of lysosomal proteases and cell death (21). Inhibiting autophagy at an early step by

Figure 3

Major stress pathways that induce autophagy. (a) As part of the mammalian target of rapamycin (mTOR) complex 1 (mTORC1), active mTOR phosphorylates and inactivates Ulk1. Starvation inactivates mTOR, which leads to the formation of an active Ulk1 complex in which Ulk1 phosphorylates Atg13 and FIP200. During conditions of low cellular energy, AMP-activated protein kinase (AMPK) is activated by a high ratio of AMP to ATP and induces autophagy both by phosphorylation and activation of Ulk1 and by inhibition of mTORC1 via phosphorylation of Raptor. (b) Hypoxia-inducible factor 1 (HIF-1) and BNIP3 induce autophagy following hypoxia. HIF-1 is stabilized under hypoxic conditions, which leads to increased BNIP3 transcription. BNIP3 binds Bcl-2 and disrupts its inhibitory interaction with Beclin 1, leading to autophagy induction. (c) Following infection, activation of Toll-like receptors (TLRs) by pathogen-associated molecular patterns (PAMPs) causes autophagy induction. Induction downstream of TLR1/2 stimulation depends on AMPK signaling. The downstream TLR signaling molecules MyD88 and TRIF (TIR domain-containing adapter-inducing interferon- β) interact with Beclin 1 following TLR activation and disrupt the inhibitory Bcl-2/Beclin 1 complex.

Xenophagy:

selective autophagic degradation of intracellular pathogens in a host cell

PAMP:

pathogen-associated molecular pattern

DAMP:

danger-associated molecular pattern

3-MA treatment or RNAi-mediated depletion of Beclin 1 decreases AP accumulation, increasing cell viability. Similarly, enhancing AP turnover via overexpression of Beclin 1 reduces AP accumulation and is also cytoprotective. Additional studies that more carefully monitor changes in autophagic flux and dissect the effects of inhibiting the early versus late steps in autophagy during I/R remain to be done.

Further evidence for the cytoprotective role of autophagy during I/R comes from studies of cardiac preconditioning. Cardiac preconditioning consists of repeated brief periods of ischemia induced before I/R, and it is one of the most reproducible methods of preventing tissue damage following I/R (21). Autophagy is upregulated during preconditioning, and perfusion of the dominant negative TAT (HIV-1 transactivator of transcription) fusion protein Atg5-K130R inhibits autophagy and blocks the protective effect of preconditioning (28). In vitro, the cardioprotective drugs uridine-5'-triphosphate, diazoxide, and ranolazine also induce autophagy, and Atg5-K130R expression similarly blocks their cytoprotective effects (28).

Overall, the current data suggest that autophagy plays a cytoprotective role during cardiac I/R injury but that, during reperfusion, the induction of autophagy coupled with a block in flux causes a cytotoxic buildup of the lysosomal compartment. Therefore, therapies that induce AP formation without increasing autophagic flux may cause more harm than good in I/R; in such contexts, inhibitors that block early steps of autophagy may be cytoprotective, at least during reperfusion. Further research is necessary to determine whether autophagy modulation is a viable therapy in cardiac I/R injury.

Autophagy and the Host Response to Infection

Autophagy represents one of the most ancient innate immune responses and is the first line of defense against bacterial, protozoan, and viral pathogens (17). Xenophagy, or degradation of foreign pathogens by autophagy, is the most

direct innate immune response in the cell, and multiple studies have confirmed this important role for autophagy following infection. For example, a subset of *Salmonella typhimurium* bacteria are targeted to APs following infection, and autophagy-deficient *Atg5^{-/-}* cells are more permissive for cytosolic growth (29). Similarly, APs are targeted to *Sindbis virus* in infected neurons, and Atg5 knockdown leads to delayed viral clearance and increased cell death (30).

Intriguingly, numerous pathogens have evolved mechanisms to evade, suppress, or subvert the host autophagic machinery. Cytosolic *Listeria monocytogenes* evade autophagic recognition by recruitment of host cytoskeletal proteins; the bacterial surface protein ActA interacts with the Arp2/3 complex and actin, masking the bacteria behind host proteins. Unlike wild-type *L. monocytogenes*, ActA mutant bacteria are efficiently targeted to APs (31). Likewise, *Shigella flexneri* evade autophagy by secreting IcsB, which competitively binds the bacterial surface protein VirG and prevents its interaction with the autophagy machinery component Atg5 (32). Alternatively, *Mycobacterium tuberculosis* block AP maturation, suppressing autophagic flux altogether. Rapamycin treatment or starvation overcomes this block and leads to decreased intracellular survival of the bacteria (33). Other pathogens, such as *Coxiella burnetii*, subvert the autophagic machinery and use autophagic vacuoles as sites of replication (34).

Through its role in xenophagic clearance of pathogens, autophagy acts as a direct and critical effector of PRR signaling following infection. PRRs are activated by pathogen-associated molecular patterns (PAMPs) and cellular stress signals known as danger-associated molecular patterns (DAMPs), thereby allowing recognition of specific pathogens or stress conditions associated with infection (17). The four main classes of PRRs are Toll-like receptors (TLRs), nucleotide-binding oligomerization domain (NOD) leucine-rich repeat-containing receptors (NLRs), retinoic acid-inducible gene 1 protein (RIG-I)-like helicase receptors (RLRs), and C-type lectin

receptors. Autophagy induction downstream of TLR activation has been the best characterized. TLR1, TLR2, TLR4, TLR5, and TLR6 recognize mainly bacterial PAMPs, whereas TLR3, TLR7, TLR8, and TLR9 recognize primarily viral molecules. Autophagy is induced downstream of both bacterial and viral TLRs. The mycobacterial lipoprotein LpqH activates autophagy downstream of TLR1 and TLR2 (19). The TLR4 ligand lipopolysaccharide (LPS), another bacterial molecule, induces autophagy and enhances autophagic degradation of *M. tuberculosis* (35). Activation of TLR3 with the synthetic double-stranded RNA analog polyinosinic-polycytidylic acid, or activation of TLR7 with single-stranded RNA, stimulates formation of GFP-LC3 puncta and formation of LC3-II (**Figure 2b**) (36).

Our understanding of the signaling pathways that connect TLR activation to autophagy induction remains incomplete. Autophagy induction following TLR1/2 stimulation with LpqH is mediated by AMPK signaling (**Figure 3c**), and depletion or inhibition of AMPK decreases AP formation following stimulation (19). Furthermore, Shi & Kehrl (18) demonstrated an interaction between the TLR downstream signaling molecules MyD88 and TRIF (TIR domain-containing adapter-inducing interferon- β) and the autophagy protein Beclin 1. This finding suggests that Beclin 1 recruitment to TLR signaling components mediates autophagy induction. The interaction between Beclin 1 and MyD88 or TRIF is enhanced by TLR signaling and leads to disruption of the inhibitory Bcl-2/Beclin 1 complex, similar to BNIP3-dependent disruption of Bcl-2/Beclin 1 following hypoxia (**Figure 3b,c**).

Autophagy machinery components also directly interact with PRRs and DAMPs. The NLRs NOD1 and NOD2 recruit the essential autophagy protein Atg16L1 to sites of bacterial entry at the plasma membrane, leading to AP formation at these sites (37). High-mobility group box 1 (HMGB1) is a nuclear chromatin-associated protein that is released into the cytosol and extracellular space following oxidative stress or necrotic cell death;

it acts as a DAMP. Interestingly, HMGB1 was recently identified as a novel binding partner of Beclin 1. Following release into the cytosol, HMGB1 competitively binds Beclin 1, disrupting the inhibitory Bcl-2/Beclin 1 complex (38). Finally, the Atg12-Atg5 conjugate directly interacts with the RLRs RIG-I, MDA5, and MAVS. This observation points to a potential noncanonical role for Atg12-Atg5 in infection because, in this case, autophagy components negatively regulate RLR signaling and subsequent type I interferon (IFN) production, thereby suppressing the antiviral immune response. In contrast, autophagy itself generally plays a positive role in antiviral immunity (39). Additional noncanonical roles of ATGs have emerged in recent years and are discussed in the sidebar, Noncanonical Functions of ATGs.

NONCANONICAL FUNCTIONS OF ATGS

Although ATGs are traditionally thought to function solely as autophagy mediators, several recent studies have determined that these proteins also possess autophagy-independent functions. The Atg12-Atg5 conjugate directly interacts with RLRs, suppressing the antiviral immune response (39). Interestingly, noncanonical ATG functions may be a common feature of the immune response. Following infection, the protozoan *Toxoplasma gondii* induces formation of a parasitophorous vacuole that acts as a replication site. Atg5 mediates recruitment of the IFN- γ -inducible GTPase IIGP1 to the vacuole, which causes membrane disruption. Surprisingly, this process does not involve AP formation, suggesting that this antiparasitic role of Atg5 is autophagy independent (147). Similarly, coronaviruses induce formation of double-membrane vesicles (DMVs) that act as sites of replication. Nonlipidated LC3 decorates the DMV surface and is necessary for coronavirus infection; this process occurs independently of Atg7 (148).

ATGs may also play autophagy-independent roles outside the context of infection. Recently, a novel conjugation of Atg12 to Atg3 was uncovered. The Atg12-Atg3 complex does not affect classic macroautophagy but instead modulates mitochondrial homeostasis and cell death (149). Rubinstein et al. (150) recently identified a novel proapoptotic role for free Atg12. Atg12 binds and negatively regulates antiapoptotic Bcl-2 family members via a BH3-like motif.

Autophagy adaptor (cargo receptor):

adaptor protein that mediates AP targeting to cargo (e.g., mitochondria and protein aggregates), often via ubiquitin- and LC3-binding domains

Basal autophagy:

constitutive autophagic degradation that proceeds in the absence of any overt stress or stimulus and serves an important housekeeping role

Abundant evidence points to a crucial role for autophagy adaptors, also known as cargo receptors, in targeting pathogens to APs. These adaptors include p62/sequestosome 1, nuclear dot protein 52 kDa (NDP52), neighbor of BRCA1 gene 1 (NBR1), and Optineurin (OPTN), all of which bind both ubiquitin and LC3 family members such as LC3 and GABARAP-1, mediating recruitment of LC3-positive isolation membranes to ubiquitinated targets (**Figure 4a**) (40–44). Accordingly, ubiquitinated proteins decorate the surface of cytosolic bacteria and are one of the main signals recognized by autophagy adaptor proteins (**Figure 4b**) (45). Autophagic degradation of several pathogens, including *S. typhimurium*, *L. monocytogenes*, *S. flexneri*, and *Sindbis virus*, is mediated by p62 (30, 31, 46, 47); both NDP52 and OPTN promote autophagic degradation of *S. typhimurium* (43, 44).

In addition to these cargo receptors, other regulators of clearance have been identified that do not depend on an ubiquitin signal. As described above, the essential autophagy protein Atg5 directly binds to VirG on the surface of *S. flexneri* (32). The adaptor Tecpr1 interacts with both Atg5 and WIPI-2 (the mammalian ortholog of Atg18), mediating the targeting of early isolation membranes to *S. flexneri* (48). Recently, galectin 8 was identified as a novel adaptor that mediates the autophagic degradation of *S. typhimurium*. Galectin 8 binds host glycans exposed on ruptured *Salmonella*-containing vesicles and recruits NDP52 to these sites; galectin-mediated NDP52 recruitment precedes and is independent of ubiquitin-mediated recruitment (**Figure 4b**) (49). Interestingly, galectin 8—as well as galectins 3 and 9—also binds host glycans on damaged endosomes and lysosomes in the absence of infection, which suggests that these galectins act as general sensors of vesicle damage (49).

Autophagy plays other, less direct roles in the response to infection, in addition to its primary role in pathogen clearance. Autophagy acts as a topological inversion mechanism that

engulfs and delivers cytosolic PAMPs to endosomal PRRs and to major histocompatibility complex class II (MHC II) compartments for antigen loading. The topological inversion function of autophagy is important for multiple components of the immune response including PRR activation in the innate immune response, activation of helper T cells in the adaptive immune response, and the prevention of autoimmunity (17). Evidence of the latter function was demonstrated in thymus-specific *Atg5*-deficient mice. The presentation of self-derived antigens by MHC II on thymic epithelial cells is essential for the generation of self-tolerant T cells, and deletion of *Atg5* leads to altered T cell selection and multiorgan inflammation (**Table 2**) (50). Finally, autophagy modulates the proinflammatory response. Secretion of the proinflammatory cytokines interleukin (IL)-1 β and IL-18 is enhanced in *Atg16L1* and *Atg7* null macrophages, which suggests that basal autophagy suppresses the proinflammatory response (51). This process is mediated at least in part by accumulation of damaged mitochondria in autophagy-deficient cells (discussed in detail below) and release of mitochondrial DNA into the cytosol, leading to increased signaling through the NALP3 (a NOD-like receptor family member) inflammasome (52). Interestingly, although basal autophagy suppresses IL-1 β production, the opposite is true of autophagy induction. Dupont et al. (53) recently identified a novel autophagy-dependent export pathway for extracellular secretion of IL-1 β that requires Atg5, GORASP2 (the mammalian Golgi reassembly stacking protein paralog of GRASP55), and Rab8a, a regulator of exocytosis. Autophagy induction by starvation increases IL-1 β secretion in response to multiple proinflammatory agonists, and inhibition of autophagic flux reduces IL-1 β secretion. These data suggest that autophagy is uniquely able to both suppress proinflammatory signaling during basal conditions and upregulate proinflammatory signaling when induced during times of stress.

a Domain architecture of cargo receptors

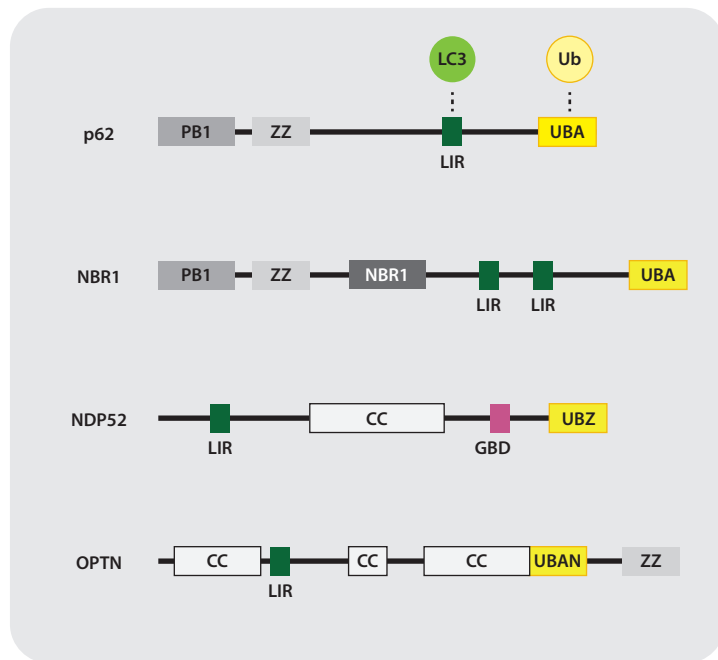

b Xenophagy adaptors

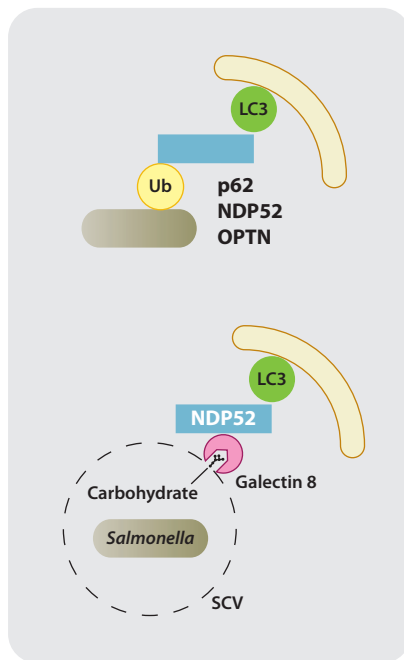

c Adaptors that mediate degradation of protein aggregates

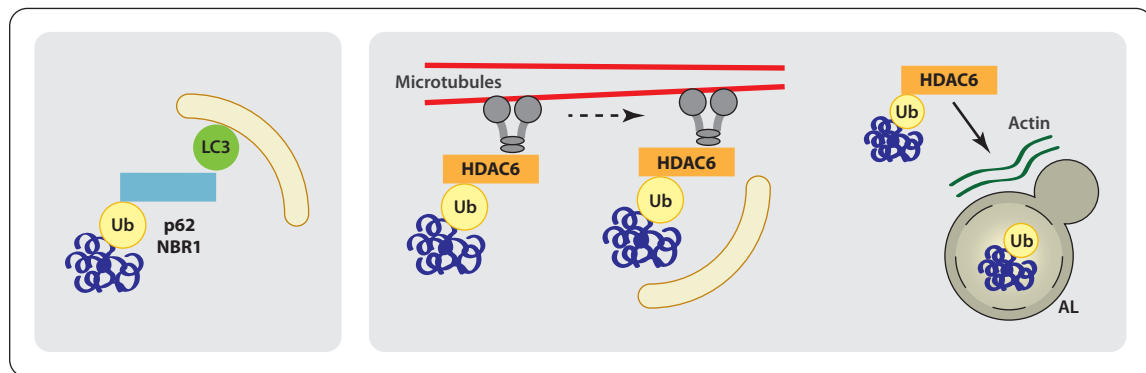

Figure 4

Degradation of ubiquitinated autophagy substrates. (a) Domain architecture of the autophagy cargo receptors p62, neighbor of BRCA1 gene 1 (NBR1), nuclear dot protein 52 kDa (NDP52), and Optineurin (OPTN). These autophagy adaptors contain an ubiquitin (Ub)-binding domain (UBA, UBZ, UBAN) and an LC3-interacting region (LIR), which mediate the recruitment of LC3-containing autophagosomes (APs) to ubiquitinated cargo. (b) The adaptors p62, NDP52, and OPTN mediate the degradation of ubiquitinated pathogens via Ub-binding domain and LIR interactions. During *Salmonella* infection, galectin 8 binds host carbohydrates exposed on ruptured *Salmonella*-containing vesicles (SCVs) and recruits NDP52 to these sites, thereby mediating AP recruitment. (c) p62 and NBR1 also mediate the degradation of ubiquitinated protein aggregates via UBA and LIR interactions. Histone deacetylase 6 (HDAC6) is important for the clearance of ubiquitinated aggregates and mitochondria. HDAC6 interacts with Ub, dynein motors, and the actin-remodeling machinery to promote dynein-mediated transport of ubiquitinated substrates to APs and enhanced AP-lysosome fusion at these sites. Abbreviation: AL, autolysosome.

IL-1 β lacks the signal sequence directing it to the conventional secretory pathway via the Golgi apparatus and the endoplasmic reticulum (ER). Interestingly, recent studies suggest that autophagy may play a general role in unconventional protein secretion. Autophagy is involved in unconventional secretion of the acyl-CoA-binding protein (Acb1/AcbA) in yeast and *Dictyostelium*; this process is mediated by delivery of APs containing Acb1/AcbA to the plasma membrane rather than the lysosome (54). In mammalian cells, unconventional secretion of the DAMP HMGB1 and the cytokine IL-18 is increased following autophagy induction, similarly to IL-1 β (53). Together, these data suggest that autophagy may play a more general role in secretion during the immune response.

Autophagy in Crohn's Disease

Crohn's disease is a chronic form of inflammatory bowel disease that affects the intestines. The mechanisms underlying Crohn's pathogenesis include an abnormal inflammatory response, abnormal Paneth cell granule secretion, and impaired intracellular bacterial clearance (55, 56). Autophagy has been implicated in the etiology of this disease by genome-wide association studies identifying disease-related polymorphisms in *Atg16L1*, immunity-related GTPase family M protein (IRGM), and NOD2 (**Table 1**) (57). *Atg16L1* forms a complex with the *Atg12-Atg5* conjugate and is necessary for proper AP elongation (**Figure 1b**). Both IRGM and NOD2 are involved in the autophagic response to infection. IRGM induces autophagy in response to IFN- γ , leading to increased clearance of bacterial pathogens (58). As described above, the PRR NOD2 recruits *Atg16L1* to bacterial entry sites, targeting bacteria for autophagic degradation (37).

Studies of *Atg16L1*, *Irgm1*, and *Nod2* knockout mice have provided critical insight into the mechanisms that drive Crohn's disease progression. *Atg16L1* hypomorphic mice have Paneth cell abnormalities and defects in granule secretion similar to those of Crohn's patients who are homozygous for the *ATG16L1* disease allele

(**Table 2**) (55). Interestingly, Paneth cell abnormalities are not observed when *Atg16L1* hypomorphic mice are raised in gnotobiotic conditions. Administration of a specific strain of the enteric murine norovirus (MNV) that is capable of establishing persistent infection recapitulates Paneth cell abnormalities. Combined MNV infection and treatment with the inflammatory agent dextran sodium sulfate (DSS) induce intestinal injury and lead to further abnormalities that are characteristic of Crohn's disease, including blunted intestinal villi and increased intestinal inflammation (59). Surprisingly, the rates of MNV replication in *Atg16L1* hypomorphic mice are equivalent to those in wild-type mice, which suggests that defects in viral clearance do not underlie disease pathogenesis. Instead, intestinal damage depends on tumor necrosis factor α , IFN- γ , and the presence of commensal bacterial flora, which indicates that an abnormal proinflammatory response of *Atg16L1* hypomorphic mice—in the context of viral infection in combination with commensal bacteria—plays a major role in the development of Crohn's disease-like abnormalities (59). Another study has demonstrated that macrophages from chimeric mice lacking *Atg16L1* in hematopoietic cells have increased IL-1 β production in response to LPS stimulation or infection with noninvasive enteric bacteria. These mice are highly sensitive to DSS-induced colitis, suggesting that increased proinflammatory cytokine secretion from hematopoietic cells may also promote intestinal damage in *Atg16L1*-dependent Crohn's disease (51).

Irgm1 null mice have impaired clearance of intracellular bacteria, lymphopenia, and defects in macrophage function (**Table 2**) (60, 61). Together with data demonstrating that IRGM is important for the induction of autophagy and autophagic degradation of bacteria following infection (58), this observation suggests that autophagy defects underlie the impaired bacterial clearance observed in Crohn's disease patients. NOD2 disease variants are also associated with reduced autophagic clearance of bacteria (**Table 2**) (62). *Nod2* null mice have defects in their response to the bacterial PAMP muramyl

dipeptide (MDP) and increased susceptibility to bacterial infection (63). Mutant mice expressing the disease-associated allele of NOD2 have increased proinflammatory cytokine secretion in response to NOD2 stimulation and increased sensitivity to DSS-induced intestinal inflammation (64). Interestingly, Atg16L1 directly interacts with NOD2, which implicates a common role for the two proteins in Crohn's disease pathogenesis. As described above, NOD2 recruits Atg16L1 to sites of bacterial entry (37). Both NOD2 and Atg16L1 are necessary for autophagy induction in intestinal epithelial cells following NOD2 stimulation with MDP, and the disease variant of Atg16L1 blocks MDP-mediated bacterial killing (65). Together, these data suggest that the defects in *Nod2* deficient or mutant mice are at least partly due to impaired autophagic clearance of bacteria.

Further direct support for the role of autophagy in Crohn's disease pathogenesis comes from *Atg5* and *Atg7* conditional knockout mice (Table 2). Mice lacking *Atg5* or *Atg7* in intestinal epithelial cells develop Paneth cell and granule secretion defects that phenocopy Atg16L1 hypomorphic mice and resemble abnormalities observed in Crohn's disease patients who are homozygous for the *ATG16L1* disease allele (55, 66). Overall, given the important role of autophagy in xenophagic bacterial clearance, modulation of proinflammatory cytokine secretion, and contribution to extracellular secretion pathways, defects in autophagy may underlie multiple mechanisms that promote Crohn's disease pathogenesis.

AUTOPHAGY IN CELLULAR QUALITY CONTROL AND HOMEOSTASIS

Although autophagy was initially identified as a cellular response to stress, it has long been recognized that cells exhibit a basal level of autophagy that is independent of nutrient and stress status. The two principal degradation pathways in the cell are the ubiquitin-proteasome system (UPS) and autophagy.

Whereas the UPS degrades mainly short-lived proteins, autophagy specializes in the removal of long-lived proteins, and unlike the UPS, it is uniquely able to degrade whole organelles such as mitochondria, peroxisomes, and the ER (67). The homeostatic role of autophagy involves both nonselective degradation, which supports basal turnover of cytoplasmic components, and selective degradation, which specifically targets damaged or aggregated organelles and proteins. Selective autophagy serves an essential cellular quality-control function in cells (67).

The generation of tissue-specific conditional knockout *Atg5* and *Atg7* mice first revealed the essential role for basal autophagy in the degradation of protein aggregates and damaged organelles (Table 2). *Atg7*-deficient hepatocytes and β cells, *Atg5*-deficient cardiomyocytes, and *Atg5*- or *Atg7*-deficient muscle cells accumulate abnormal mitochondria and ubiquitin-positive protein aggregates and inclusion bodies (8, 68–72). Ubiquitinated protein aggregates also accumulate in the brains of neuron-specific *Atg5* and *Atg7* knockout mice (73, 74). In addition to mitochondrial abnormalities, *Atg7* null hepatocytes accumulate peroxisomes, and in *Atg7* null β cells the ER and Golgi apparatus are abnormally distended (8, 69). Importantly, in *Atg5*-deficient neurons, diffuse ubiquitin-positive proteins accumulate before protein aggregates are observed, which supports the idea that autophagy plays a crucial role in basal protein turnover in addition to the degradation of damaged or aggregated proteins (73).

As in xenophagy, autophagy adaptors target the autophagy machinery to specific substrates, such as ubiquitinated proteins or depolarized and/or damaged mitochondria; p62 and NBR1, which bind both LC3 family members and ubiquitin and promote autophagic degradation of ubiquitinated substrates, also mediate the removal of protein aggregates (Figure 4a,c). Thus, autophagy-deficient cells accumulate ubiquitin-positive aggregates containing p62 and NBR1 (41, 42). Another ubiquitin-binding protein, histone deacetylase 6 (HDAC6), is important for autophagic clearance of both

Mitophagy:
selective autophagic
degradation of
damaged or
superfluous
mitochondria

protein aggregates and mitochondria. In contrast to other adaptors that interact with components of the autophagy machinery, HDAC6 recruits dynein microtubule motors and actin-remodeling machinery to ubiquitinated substrates, promoting transport of ubiquitinated substrates to APs and leading to enhanced fusion of APs to lysosomes at these sites (**Figure 4c**) (75, 76).

Multiple adaptors have been identified that mediate specific degradation of mitochondria by autophagy, a process termed mitophagy (77). Nix, also known as BNIP3L1, is a mitochondria-localized BH3-only protein that is upregulated during hypoxia. In response to mitochondrial stressors, Nix promotes mitochondrial depolarization and subsequent formation of reactive oxygen species (ROS), leading to autophagy induction via stress-response pathways. Moreover, Nix binds LC3 family members, particularly GABARAP-L1, which mediates targeting of APs to depolarized mitochondria (**Figure 5a,b**) (78, 79). Another recently described mitochondrial protein, FUNDC1 (**Figure 5a**), interacts with LC3 following its hypoxia-induced dephosphorylation, acting as a mitophagy receptor following oxygen deprivation (80).

The best-described mitophagy pathway involves the proteins PTEN-induced putative kinase 1 (PINK1) and Parkin (**Figure 5c**). The mitochondrial resident protein PINK1 is constitutively degraded in healthy mitochondria; this process is mediated by membrane potential-dependent cleavage of PINK1 by the inner mitochondrial membrane protease PARL

(presenilin-associated rhomboid-like protein) (81). Following mitochondrial depolarization, PINK1 accumulates on the outer mitochondrial membrane (OMM) and recruits the E3 ubiquitin ligase Parkin. Parkin ubiquitinates multiple proteins on the OMM, which leads to proteasomal degradation of OMM components followed by AP recruitment and autophagic degradation of damaged mitochondria (82–87). Notably, other mitophagy adaptors also play a role in Parkin-mediated mitophagy. Because Nix promotes mitochondrial depolarization, it also promotes Parkin translocation (78). NBR1 and p62 colocalize with Parkin-positive mitochondria and mediate AP targeting to damaged, ubiquitin-positive mitochondria (82). Interestingly, on depolarized mitochondria, stabilized PINK1 also phosphorylates Miro, an adaptor protein that connects the motor protein kinesin to the OMM surface. Phosphorylation of Miro leads to its Parkin-dependent degradation and subsequently to mitochondrial arrest, suggesting that the PINK1-Parkin pathway serves as a mechanism to isolate damaged mitochondria in addition to promoting mitophagic degradation (88).

THE HOMEOSTATIC AND QUALITY-CONTROL ROLES OF AUTOPHAGY PREVENT CELL INJURY AND DISEASE

Basal autophagy may be particularly important in postmitotic cells such as neurons and myocytes because such cells, unlike dividing cells, cannot dilute out damaged proteins and

Figure 5

Mitophagy. (a) Domain architecture of the mitophagy adaptors Nix and FUNDC1. Both proteins contain a transmembrane domain (TM) embedded in the outer mitochondrial membrane (OMM) as well as an LC3-interacting region (LIR), which mediates the recruitment of autophagosomes (APs) to mitochondria. (b). Following mitochondrial stress, Nix promotes mitochondrial depolarization and reactive oxygen species (ROS) formation, leading to autophagy induction. Nix also mediates the targeting of APs to mitochondria via its LIR. (c) In healthy polarized mitochondria, PINK1 is constitutively degraded by the inner mitochondrial membrane protease PARL. Following depolarization, full-length PINK1 accumulates on the OMM and recruits the E3 ligase Parkin. Parkin ubiquitinates multiple OMM proteins, causing the proteasomal degradation of OMM components and p62/NBR1-mediated recruitment of APs to mitochondria. Abbreviations: NBR1, neighbor of BRCA1 gene 1; Ψ_m , mitochondrial membrane potential.

a Mitochondrial LIR-motif proteins

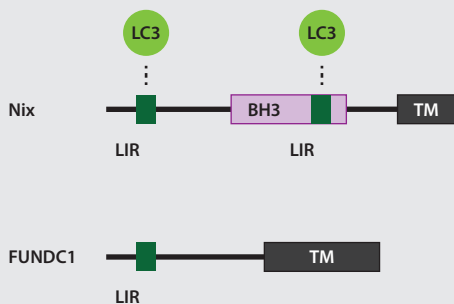

b Dual roles for Nix in mitophagy

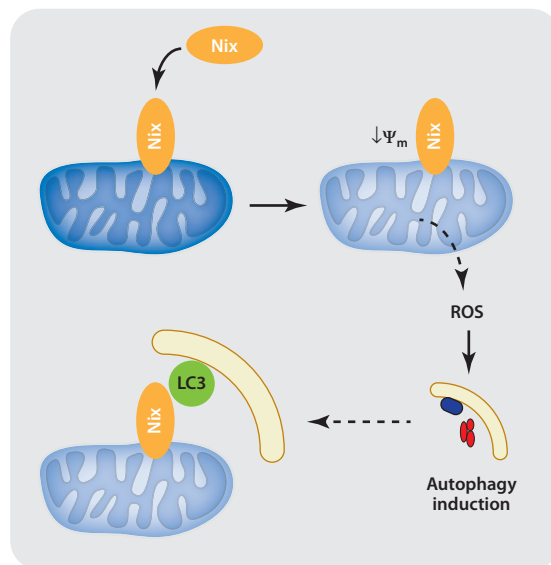

c PINK1/Parkin mitophagy pathway

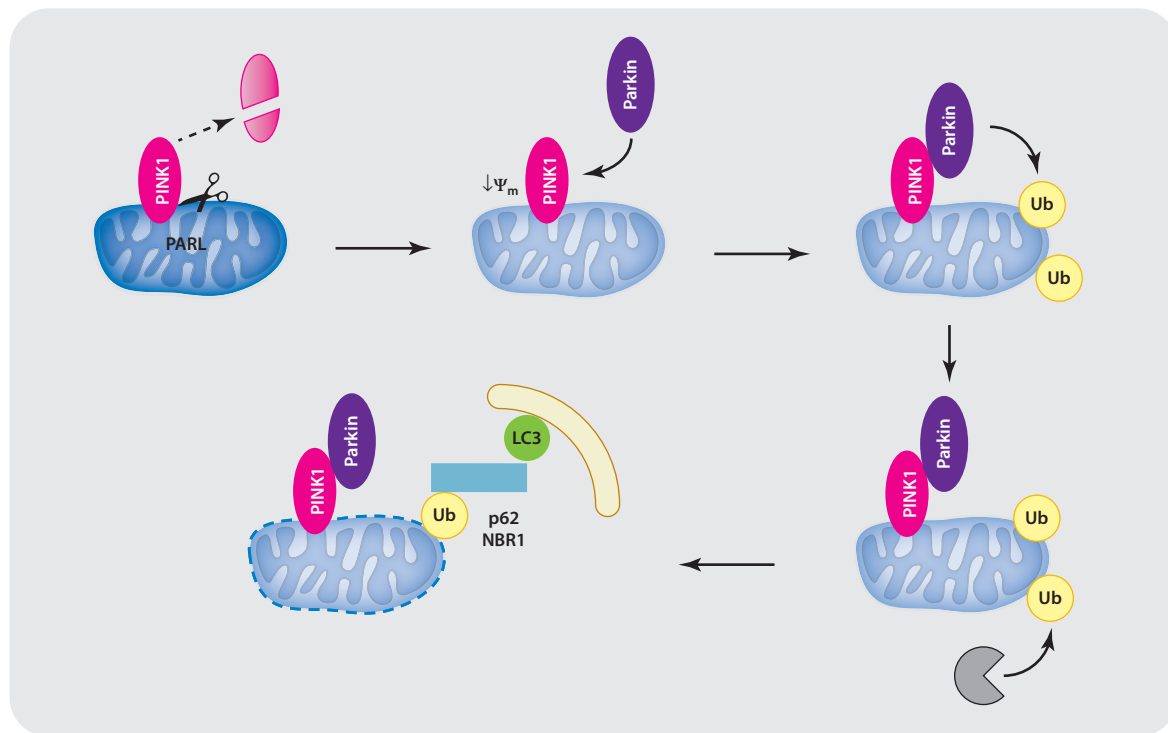

PD: Parkinson's disease

AD: Alzheimer's disease

HD: Huntington's disease

organelles into daughter cells (1). Indeed, loss of autophagy in neurons or muscle generally leads to atrophy and cell death, as described in detail below (70, 72–74). Highly secretory cells such as hepatocytes and β cells may also depend more on intact autophagy because they produce large quantities of protein in the ER, which leads to higher levels of misfolded proteins and aggregates (89). In this section, we discuss the role of autophagy in these tissues and describe how impaired basal autophagy may contribute to diseases such as neurodegeneration, myopathy, liver disease, and diabetes.

Autophagy in Neurodegenerative Disease

Basal autophagy is essential for proper neuron function and generally plays a cytoprotective role, preventing buildup of protein aggregates and damaged mitochondria. Neuron-specific *Atg5* and *Atg7* knockout mice develop progressive motor defects accompanied by neurodegeneration and accumulation of polyubiquitinated proteins and aggregates (Table 2) (73, 74). Interestingly, Beclin 1 expression decreases with age in the human brain, suggesting that decreased autophagy may underlie the observed association between advanced age and increased incidence of neurodegenerative disease (90). Autophagy has been implicated in numerous neurodegenerative diseases; here, we focus on Parkinson's disease (PD), Alzheimer's disease (AD), and Huntington's disease (HD).

Autophagy in Parkinson's disease. PD is caused by the degeneration of dopaminergic neurons in the substantia nigra. Characteristic features of PD include accumulation of autophagic vacuoles, abnormal mitochondrial function, and the presence of intracellular inclusions named Lewy bodies containing the proteins α -synuclein and ubiquitin (77). Although most PD cases are sporadic, approximately 10% of cases are hereditary. Studies of familial inherited forms of PD have identified multiple disease-associated mutations, which

have provided insight into the etiology of both hereditary and sporadic PD and have implicated alterations in autophagy in disease pathogenesis (Table 1).

The first identified PD-associated polymorphism was in α -synuclein, the major component of Lewy bodies. PD-associated mutations in α -synuclein cause this protein to form amyloid-like fibrils associated with disease progression. Transgenic mice that overexpress a disease-associated mutant A53T α -synuclein develop protein inclusions accompanied by neurodegeneration and motor defects, mimicking PD (91). Wild-type and disease-associated mutant α -synuclein are degraded by macroautophagy, CMA, and the proteasome (92–94). Mutant α -synuclein inhibits CMA by blocking the LAMP2A receptor, preventing protein translocation into the lysosome and subsequent degradation; the cell compensates for this defect in CMA by upregulating autophagy (92). Autophagy upregulation in A53T-expressing neurons in vitro leads to a profound loss of mitochondrial mass accompanied by depletion of cellular ATP and cell death (95), and treatment with 3-MA or knockdown of Parkin or Beclin 1 partially protects against A53T-mediated cytotoxicity (95, 96). Overall, these data suggest that, in contrast to the usual cytoprotective role of autophagy, the compensatory upregulation of autophagy—and increased mitophagy—in response to pathogenic α -synuclein is cytotoxic and may worsen progression of familial or sporadic forms of PD caused by mutations in α -synuclein.

Interestingly, gene duplication of wild-type α -synuclein has also been implicated in familial PD (97). Whereas mutant α -synuclein induces macroautophagy, increased expression of the wild-type protein has the opposite effect. Overexpression of wild-type α -synuclein in a human neuroblastoma cell line causes mislocalization of Atg9 and suppresses AP biogenesis via inhibition of Rab1a, a GTPase involved in ER-to-Golgi apparatus trafficking (98). Transgenic mice that overexpress wild-type α -synuclein accumulate α -synuclein aggregates and abnormal APs and lysosomes in

neurons, which leads to neuron death and motor defects (99, 100). Lentiviral delivery of Beclin 1 to the brains of these mice reduces α -synuclein accumulation and disease pathology (100). Taken together, these findings suggest that imbalanced autophagy—either overactive or suppressed—can be detrimental to neuron survival in the context of α -synuclein pathology. Further research into α -synuclein pathology and alterations in autophagic flux in sporadic PD will be necessary to determine whether autophagy modulation may be beneficial or harmful in these contexts.

Mutations in PINK1 and Parkin cause an autosomal recessive form of early-onset PD (**Table 1**) (101, 102). As described above, PINK1 recruits Parkin to depolarized mitochondria, which leads to the ubiquitination of OMM proteins, AP recruitment, and mitophagic degradation (**Figure 5c**) (82–87). In cell culture systems, PD-associated mutations in PINK1 or Parkin impair mitophagy via several mechanisms, including (*a*) defects in the targeting of Parkin to depolarized mitochondria, (*b*) disruption of Parkin's E3 ligase activity, and (*c*) formation of nonfunctional proteins that aggregate in intracellular inclusions (86, 103, 104). Fibroblasts isolated from patients with Parkin mutations have decreased mitochondrial complex I activity, which suggests that these cells have impaired mitochondrial function; complex I activity defects are also observed in the substantia nigra of patients with sporadic PD (105, 106). Together, these data support the model that mitophagy defects at least partly underlie PD pathogenesis.

Surprisingly, *Parkin* and *Pink1* knockout mice do not recapitulate PD (**Table 2**). Mice lacking Parkin or Pink1 have mitochondrial defects, including decreased complex I activity, reduced respiration, and increased sensitivity to oxidative stress, but these defects occur in the absence of substantia nigra degeneration (107, 108). Similar to PD patients, aged *Pink1*^{-/-} mice undergo progressive mitochondrial dysfunction, weight loss, and reduction in spontaneous locomotive activity. However, they lack the Lewy body accumulation,

neurodegeneration, and decreased life span that are observed in PD patients (109). These data suggest that patients with *Parkin* or *PINK1* mutations have other genetic variations that modify neuronal sensitivity to decreased mitophagy. Alternatively, polymorphisms in *Parkin* and *PINK1* in patients may not act strictly as loss-of-function mutations; they may also exert dominant negative or dominant toxic effects. Supporting the latter hypothesis is the finding that transgenic mice that overexpress a truncated mutant form of human Parkin in dopaminergic neurons develop progressive motor defects, accompanied by substantia nigra degeneration and α -synuclein accumulation, which more closely mimics PD progression (110). Overall, the alterations in Parkin and PINK1 in patients with hereditary PD suggest that a mitophagy deficit contributes to PD pathology, although it may not be the sole cause.

One of the best-characterized mouse models of PD uses MPTP (1-methyl-4-phenyl-1,2,3,6-tetrahydropyridine) treatment. Administration of MPTP leads to a PD-like disease in both primates and mice. The toxic metabolite of MPTP, MPP⁺, accumulates in dopaminergic neurons and causes neurodegeneration and motor defects similar to those seen in PD including rigidity, tremor, and akinesia (77). In MPP⁺-treated neurons, an increase in APs precedes cell death; both (*a*) Atg5 or Atg7 knockdown and (*b*) pretreatment with the early autophagy inhibitor 3-MA abrogate MPP⁺ cytotoxicity (96, 111), suggesting that overactive autophagy enhances MPP⁺-mediated cell death. However, because these studies have not measured autophagic flux, they cannot distinguish between autophagy induction and a late block in autophagy in response to MPP⁺ (**Figure 2**). Additional studies indicate that MPTP treatment in mice or MPP⁺ treatment in cell culture leads to lysosomal membrane permeabilization and lysosomal depletion in neurons, which presumably causes a block in autophagic flux and AP accumulation. Treatment with rapamycin restores lysosomal levels, enhances AP clearance, and blocks MPP⁺-mediated cell death in vitro and

neurodegeneration in vivo (112). The mechanism by which rapamycin enhances lysosomal activity is unclear. Overall, similar to cardiac I/R injury, the results described above suggest that autophagy protects against MPTP-induced cell death but that a block in autophagic flux and the resulting lysosomal permeabilization are cytotoxic. As a result, inhibition of the initial steps of autophagy via 3-MA treatment or ATG knockdown reduces AP accumulation and is cytoprotective. Similarly, promoting autophagic flux via rapamycin treatment (by an unknown mechanism) reduces AP accumulation and increases cell viability. Overall, given the conflicting results regarding the cytotoxic versus cytoprotective effects of autophagy in different models of PD (e.g., α -synuclein and MPTP), further efforts to clarify autophagic activity and flux in PD patients and model systems will be required to determine whether autophagy modulation is a viable therapy for this disease.

Autophagy in Alzheimer's disease. AD is a form of dementia characterized by neuronal death in the cerebral cortex. The hallmarks of AD are the presence of intracellular neurofibrillary tangles containing hyperphosphorylated tau and the presence of extracellular β -amyloid ($A\beta$) plaques generated by cleavage of amyloid precursor protein (APP) by γ -secretase (77). Accumulation of APs and abnormal mitochondria are observed in postmortem brains of AD patients, which suggests that autophagy plays a role in disease progression (113). Several studies suggest that defects in autophagic maturation may be a general feature of AD pathology. AD-associated mutations in the transmembrane protein presenilin 1, which cause a form of familial early-onset AD, lead to defects in autophagic flux due to faulty targeting of the v-ATPase V0a1 subunit to the lysosome and resulting defects in lysosomal acidification (**Table 1**) (114). More broadly, immature forms of autophagic vacuoles such as isolation membranes (IMs) and APs rather than autolysosomes (**Figure 1**) accumulate in AD

brains. The accumulated autophagic vacuoles resemble those observed in primary cortical neurons following inhibition of lysosomal proteases or vinblastine treatment—both of which block AP maturation—suggesting that AP accumulation in AD brains is at least partly caused by a block in autophagic flux (113, 115, 116).

Other studies have demonstrated that autophagy plays a role in the degradation of pathogenic APP and tau. In cells that stably express wild-type APP or an AD-associated mutant APP, Beclin 1 knockdown leads to the accumulation of APP and $A\beta$, whereas autophagy induction via Beclin 1 overexpression or rapamycin treatment decreases APP and $A\beta$ levels (117, 118). Supporting these in vitro data is the finding that reduced Beclin 1 levels accompanied by increased APP and $A\beta$ levels are observed in AD patients. Additionally, *Beclin1* heterozygous mice that express AD-associated mutant APP have increased APP and $A\beta$ aggregation and more severe neurodegeneration compared with wild-type mice expressing mutant APP (118, 119). In keeping with the putative autophagic flux defect found in brains of AD patients, APP overexpression itself leads to AP accumulation in cell culture models, probably because of a maturation defect; however, further studies that more directly measure autophagic flux (**Figure 2c**) remain to be done. Interestingly, both APP and γ -secretase accumulate in APs, which suggests that the autophagic compartment can also act as a source of pathogenic $A\beta$ when AP maturation is impaired (116). Pathogenic tau is also degraded by autophagy. Autophagy inhibition by 3-MA increases tau aggregation and toxicity, and autophagy induction with rapamycin decreases toxicity in cells that overexpress mutant tau (120, 121).

There are conflicting data about whether autophagy is cytoprotective or cytotoxic in AD. Autophagy inhibition generally increases tau toxicity, whereas rapamycin decreases toxicity (120, 121). Similarly, *Atg7* knockdown increases $A\beta$ toxicity in a neuroblastoma cell line, and *Beclin1* heterozygous mice have increased susceptibility to APP-induced

neurodegeneration (118, 119, 122). However, another study indicates that inhibition of autophagy by 3-MA treatment or Beclin 1 knockdown decreases A β toxicity in human neuroblastoma and glioma cell lines (123). Once again, an intriguing possibility is that autophagy inhibition in AD models can be either cytoprotective or cytotoxic, depending on the level of autophagic flux and the degree of lysosomal impairment in each system. In this case, autophagy inhibition is cytoprotective in cells with profound impairment in autophagic maturation—in which there is expansion of the autophagosomal/lysosomal compartment and increased A β production—but cytotoxic in cells with less severe impairment in flux.

Although there are conflicting data about autophagy inhibition in AD models, autophagy induction using rapamycin generally plays a cytoprotective role. In a mouse model of AD that employed transgenic mice expressing both pathogenic APP and tau, autophagy induction by rapamycin rescued cognitive deficits and decreased accumulation of A β and tau aggregates (117). Rapamycin may promote both autophagy and lysosomal function in AD models, as is the case in MPTP models of PD, and thus can rescue autophagic flux defects. Overall, further research is required to determine the feasibility of autophagy modulation as a treatment for AD; such research should include interrogating the changes in autophagic flux that occur during AD pathogenesis and dissecting the effects of specifically manipulating discrete stages of autophagy in AD patients.

Autophagy in Huntington's disease. HD is an autosomal dominant neurodegenerative disease caused by a trinucleotide CAG (polyglutamine) expansion within the protein huntingtin (htt). HD causes the death of striatal and cortical neurons accompanied by mitochondrial dysfunction and accumulation of mutant htt within inclusion bodies (77). Polyglutamine-expanded (polyQ) htt is degraded by autophagy, which suggests that increased autophagy may provide a therapeutic benefit in HD. Mutant htt accumulates in APs

(124, 125), and autophagy inhibition by Beclin 1 knockdown increases levels of polyQ-htt (90). In contrast, autophagy induction by rapamycin enhances clearance of a polyQ-htt fragment and reduces htt-dependent cell death (125).

Interestingly, in mouse and human cellular models of HD and cells from HD patients, AP formation and clearance are normal but autophagic vacuoles contain little cargo, suggesting that impaired cargo recognition and the resulting defect in engulfment of cytoplasmic components underlie the accumulation of dysfunctional mitochondria and protein aggregates observed in HD (126). The cargo recognition defect may be caused in part by the sequestration of p62 by mutant htt (126). Given that the inefficient recognition of autophagic substrates may cause certain defects in HD, either increasing the efficiency of autophagic cargo degradation or simply increasing overall levels of autophagy may be therapeutically useful in HD patients. Indeed, treatment with rapamycin or a rapamycin analog reduces htt aggregates and slows neurodegeneration in fly and mouse models of HD (127).

Autophagy in Myopathy

Myopathy is defined as muscle weakness caused by muscle fiber dysfunction. There are many forms of myopathy with distinct pathologic features including muscle cell degeneration, cellular changes leading to reduced contractile function, mitochondrial alterations leading to energy deficits, metabolic defects, and abnormal inflammation. Basal autophagy is essential for maintenance of proper muscle mass and function, and defects in autophagy are sufficient to cause myopathy in mice. Muscle-specific *Atg5* and *Atg7* knockout mice develop severe muscle atrophy and progressive muscle weakness accompanied by accumulation of abnormal mitochondria, accumulation of ubiquitinated proteins, and abnormal lysosome distribution (**Table 2**) (70, 72). Autophagy also protects against stress-induced myopathy; it is induced in muscle cells in response to muscle atrophy induced by starvation or denervation

(128, 129), and mice whose myocytes lack *Atg7* have increased muscle loss in response to either of these stresses (70). The autophagic response to muscle atrophy is mediated in part by BNIP3 (**Figure 3b**) (130).

Direct evidence for the importance of autophagic flux for muscle maintenance in humans can be found in a group of myopathies characterized by lysosomal defects (**Table 1**). Pompe disease is caused by a defect in lysosomal α -glucosidase that leads to a defect in lysosomal glycogen degradation and severe myofibril loss. In a mouse model of Pompe disease, muscle-specific loss of α -glucosidase leads to muscle atrophy, along with autophagy induction coupled to a defect in AP-lysosome fusion. However, the loss of *Atg5* in addition to α -glucosidase further increases the degree of muscle loss, which suggests that the block in AP-lysosome fusion is partial and that autophagy induction may still provide therapeutic benefit to these patients (72). Danon disease is caused by defects in the lysosomal protein LAMP2B, which lead to cardiomyopathy and myopathy. The loss of LAMP2B function in human patients, as well as mice, results in the accumulation of APs due to impaired AP-lysosome fusion (131). Other lysosomal myopathies include X-linked myopathy with excessive autophagy. In each of these diseases, defects in autophagic flux are associated with severe forms of myopathy.

Although autophagy defects can lead to myopathy, excessive autophagy may also promote muscle loss under certain conditions. High levels of oxidative stress contribute to muscle disease, and transgenic mice with muscle-specific expression of mutant G93A superoxide dismutase 1, one of the major antioxidant enzymes, develop progressive muscle atrophy and mitochondrial dysfunction associated with autophagy induction (132). In this context, muscle cell degeneration may be in part due to excessive autophagy; *in vivo* RNAi-mediated knockdown of LC3 via electrotransfer partially rescues muscle atrophy (132). Jumpy (myotubularin-related protein 14) is a PI3P phosphatase that negatively reg-

ulates autophagy by reducing PI3K-dependent recruitment of WIPI-1 (WD-repeat domain phosphoinositide-interacting protein 1, a mammalian ATG18 ortholog) to APs (133). An R336Q mutation in Jumpy that renders it catalytically inactive was identified in a patient with centronuclear myopathy, a congenital myopathy in which nuclei are abnormally localized in skeletal muscle cells, leading to decreased contraction (**Table 1**). Mutant R336Q Jumpy is unable to negatively regulate autophagy (133), which suggests that overactive autophagy may contribute to muscle dysfunction in this type of myopathy. Overall, these data indicate that homeostatic levels of autophagy in muscle are cytoprotective, but that either too much or too little can lead to muscle dysfunction.

Autophagy in Liver Disease

As in muscle, proper liver function requires basal autophagy. Hepatocytes may be particularly dependent on basal autophagy due to their high biosynthetic activity and role in protein and carbohydrate storage. Mice lacking *Atg7* in the liver develop hepatomegaly and accumulate abnormal concentric membranous structures, abnormal organelles such as mitochondria and peroxisomes, and ubiquitin-positive protein inclusions (**Table 2**) (8). Liver-specific *Atg7* knockout mice also have altered lipid profiles, characterized by higher total triglyceride (TG) levels, increased TG accumulation following nutrient deprivation, and increased total cholesterol levels; these findings suggest that basal autophagy controls lipid metabolism (134).

A main cause of liver disease is chronic alcohol use. Interestingly, chronic alcohol consumption inhibits liver cell autophagy, suggesting that decreased autophagy may underlie the pathogenesis of alcoholic liver disease. Rats that are chronically fed alcohol exhibit decreased numbers of hepatic autophagic vacuoles and an accumulation of abnormal lysosomes, in parallel with decreased degradation of long-lived proteins and an accumulation of proteins and lipids (135, 136). Consistent

with an autophagy defect, patients with a form of alcoholic liver disease known as alcoholic steatohepatitis accumulate protein aggregates termed Mallory–Denk bodies (MDBs); these aggregates are composed primarily of keratin 8 and keratin 18 and are positive for ubiquitin and p62 (137). In a mouse model of MDB formation, autophagic vacuoles contained keratins 8 and 18 as well as ubiquitin, and rapamycin treatment decreased the number of MDBs (138), indicating that autophagy is involved in clearance of these aggregates. Together, these data suggest that alcohol-mediated autophagy inhibition may promote the development of alcoholic liver disease. A potential mechanism by which alcohol inhibits autophagy is through the reduction of AMPK activity. As discussed above, AMPK induces autophagy in response to low cellular ATP (**Figure 3a**). Ethanol administration reduces hepatic AMPK activity in both mice and cell culture, and the AMPK activator AICAR protects against alcohol-induced fatty liver in rats, which suggests that autophagy induction via AMPK activation may be a viable therapy in alcoholic liver disease (139, 140).

Fatty liver disease, characterized by TG accumulation in liver cells, can also occur in the absence of chronic alcohol consumption. The main risk factors for the development of nonalcoholic fatty liver disease are obesity and insulin resistance. As described above, basal autophagy regulates intracellular lipid content in hepatocytes. Following starvation, lipid droplets stored by hepatocytes are degraded by autophagy to supply free fatty acids for energy production; loss of *Atg5* or 3-MA treatment leads to increased TG storage, similar to that observed in fatty liver disease (134). Autophagy levels also modulate insulin signaling. *Atg5* and *Atg7* null mouse embryonic fibroblasts have decreased insulin receptor signaling following insulin stimulation, and *in vivo* knockdown of *Atg7* in the liver of lean mice causes severe insulin resistance (89). Together, these data suggest that decreases in hepatic autophagy can cause TG accumulation and insulin resistance and may contribute to fatty liver disease.

What mechanisms might underlie reduced autophagy in patients with fatty liver disease? Insulin is a major hormonal regulator of autophagy that suppresses autophagy induction, and obesity itself may elicit reductions in autophagy. In both genetic (*ob/ob*) and high-fat diet-induced models of obesity and insulin resistance, hepatic autophagy is decreased (89, 141). This decrease may be partly due to hyperinsulinemia, although insulin depletion by ablation of pancreatic β cells does not restore autophagy levels (89). Instead, autophagy inhibition is mediated partly by an increase in calpain 2, which degrades *Atg7*, and overexpression of *Atg7* in the liver of *ob/ob* mice partially rescues glucose tolerance and insulin sensitivity (89). Taken as a whole, these data suggest that alcohol- or obesity-mediated defects in autophagy contribute to the progression of some forms of liver disease.

Autophagy in Type 2 Diabetes

As discussed above, autophagy plays a key role in the removal of damaged mitochondria and ubiquitinated proteins and aggregates. Both of these processes—mitophagy and autophagic removal of damaged proteins—are implicated in β cell homeostasis and survival (69, 142). The removal of damaged or aggregated proteins via autophagy is especially important following ER dysfunction, known as ER stress, and β cells are particularly sensitive to ER stress because of their role in insulin secretion (69).

Direct evidence for the importance of autophagy in β cell function comes from β cell-specific *Atg7* knockout mice (*Atg7:RIP-Cre*) (**Table 2**). *Atg7:RIP-Cre* mice fed a high-fat diet phenocopy type 2 diabetes with progressive β cell degeneration, hyperglycemia, loss of insulin production, and cellular hypertrophy. The β cells of *Atg7:RIP-Cre* mice have characteristics associated with both autophagy defects and diabetes pathology, including accumulation of damaged mitochondria, reduced respiration, increased oxidative stress, and accumulation of p62-positive ubiquitinated aggregates (68, 69, 142). Ebato et al. (68) demonstrated that

autophagy maintains both β cell number and function (i.e., insulin secretion) in mice fed a high-fat diet. In mice with intact autophagy, a compensatory increase in β cell mass is observed following consumption of a high-fat diet; this increase is not observed in mice that lack pancreatic Atg7. Autophagy-deficient islet cells also have decreased insulin secretion. This defect can be partially rescued by antioxidant treatment, which suggests that increased ROS production by damaged mitochondria may play a role in suppressing secretion (142).

Data suggest that patients with type 2 diabetes have autophagy defects; patient samples have greatly increased numbers of autophagic vacuoles along with reduced LAMP2, which suggests that these patients have impaired lysosome activity and AP maturation (143). The same is true in multiple rodent models of diabetes. In a *Rab3A*^{-/-} mouse model of diabetes, APs accumulate in islet β cells in conjunction with decreased LAMP2 (144). Increased APs have also been observed through electron microscopy in *db/db* mice and ZDF rats, along with p62 accumulation in *db/db* mice and age-dependent accumulation of polyubiquitinated GFP-LC3-positive protein aggregates in ZDF rats. Again, these observations indicate that APs accumulate due to a decrease in autophagic flux (68, 145, 146). Together, these data suggest that autophagy is essential for proper β cell function, particularly in response to a high-fat diet. Autophagic flux is suppressed in diabetic

patients and in multiple models of diabetes, which suggests that decreased autophagy contributes to the development of this disease.

CONCLUSION

Autophagy plays an essential role in the adaptive response to cell stress and in the maintenance of cellular homeostasis and quality control. These two functions of autophagy are important in disease, both in responding to disease-induced cell stress and in preventing homeostatic imbalances that lead to cell injury and disease. On the whole, evidence supports the idea that autophagy plays a beneficial role in human health and disease prevention. Defects in discrete steps in autophagy—in induction, cargo recognition, or flux—are a common feature of multiple diseases, including I/R, Crohn's disease, neurodegeneration, myopathy, and diabetes; such deficiencies may drive or exacerbate disease progression (Figure 6). However, as is the case in some rare forms of myopathy and PD, too much autophagy can also be pathogenic; it can cause excessive self-digestion of cellular components. A more thorough understanding of the perturbations that occur in autophagy induction and autophagic flux in these diseases will be important for the development of therapeutics that target autophagy. Autophagy inhibitors may be useful in treating diseases with either overactive autophagy or a cytotoxic late block in autophagic flux.

Figure 6

Summary of autophagy alterations in disease and potential treatments. The major autophagy alterations in human disease and examples of diseases for each class are listed. (a) In diseases with "overactive" autophagy, inhibition of autophagy [via 3-methyladenine (3-MA) or chloroquine (CQ)] may provide therapeutic benefit. In diseases that cause a defect in (b) autophagy induction/initiation or (c) cargo recognition, patients may benefit from drugs such as rapamycin (Rap) that induce autophagy. (d) In diseases that lead to a block in autophagic maturation, Rap treatment may partially restore flux and provide a cytoprotective effect. Alternatively, in diseases with a severe block in autophagic maturation, blocking autophagy at an early step (e.g., via 3-MA) may be therapeutically useful because this block mitigates the cytotoxic accumulation of autophagosomes (APs) and lysosomes. Abbreviations: AD, Alzheimer's disease; AL, autolysosome; AP, autophagosome; HD, Huntington's disease; IM, isolation membrane; I/R, ischemia/reperfusion injury; MPTP, 1-methyl-4-phenyl-1,2,3,6-tetrahydropyridine; NAFLD, nonalcoholic fatty liver disease; PAS, phagophore assembly site; PD, Parkinson's disease.

Similarly, treatments that induce autophagy may be beneficial in diseases with a block in autophagy initiation, but they would be harmful in diseases with a severe block in autophagic maturation (Figure 6). Further research into the

basic autophagic and lysosomal machinery and upstream signaling pathways will be necessary to identify novel targets for disease therapies that induce or inhibit autophagy at its different steps.

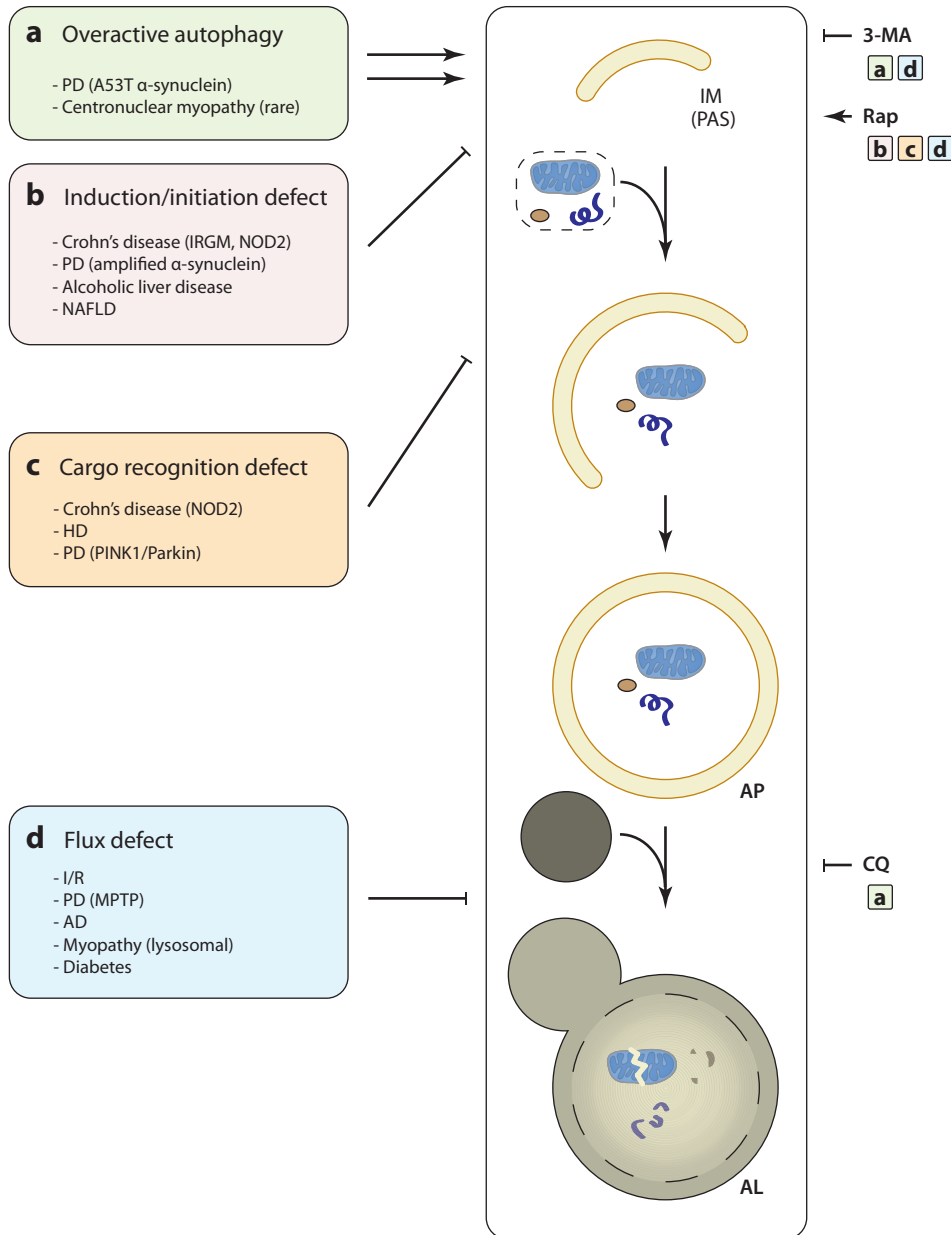

SUMMARY POINTS

1. Autophagy is an essential prosurvival pathway in cells that is induced following diverse stresses such as starvation, hypoxia, infection, and oxidative stress.
2. Autophagy also maintains cellular homeostasis in the absence of stress by promoting basal (nonselective) turnover of cytoplasmic components, including whole organelles.
3. Selective autophagy, including mitophagy and degradation of ubiquitinated substrates, is an essential cellular quality-control mechanism that degrades damaged cellular components.
4. Specific autophagy adaptors, also known as cargo receptors, are important mediators of selective autophagy.
5. Alterations in autophagy in human disease include (a) defects in autophagy induction, (b) defects in cargo recognition, (c) defects in autophagic maturation, and (d) overactive autophagy.
6. Autophagy induction (e.g., by rapamycin) may provide a therapeutic benefit in diseases with defects in autophagy induction, cargo recognition, or autophagic maturation.
7. Inhibition of the early steps in the autophagy pathway may be therapeutically useful for the treatment of diseases with a severe block in autophagic maturation; in contrast, inhibition of either early or late steps in the autophagy trafficking process may be useful for the treatment of diseases that are notable for “overactive” autophagy.
8. A more complete understanding of the autophagy alterations that occur in different diseases will be important for the development of therapeutics that target autophagy.

DISCLOSURE STATEMENT

The authors are not aware of any affiliations, memberships, funding, or financial holdings that might be perceived as affecting the objectivity of this review.

ACKNOWLEDGMENTS

Support to J.D. includes grants from the National Institutes of Health (CA126792 and ARRA Supplement CA126792-S1); an Era of Hope Scholar Award (W81XWH-11-1-0130) from the US Department of Defense Breast Cancer Research Program; Howard Hughes Medical Institute Physician-Scientist Early Career Award; and a New Frontiers Award from the University of California, San Francisco, Program for Breakthrough Biomedical Research. The material described in this review is based on work supported by the National Science Foundation Graduate Research Fellowship under grant DGE-1144247.

LITERATURE CITED

1. Mizushima N, Levine B, Cuervo AM, Klionsky DJ. 2008. Autophagy fights disease through cellular self-digestion. *Nature* 451:1069–75
2. Klionsky DJ, Cregg JM, Dunn WA Jr, Emr SD, Sakai Y, et al. 2003. A unified nomenclature for yeast autophagy-related genes. *Dev. Cell* 5:539–45

3. Klionsky DJ, Abeliovich H, Agostinis P, Agrawal DK, Aliev G, et al. 2008. Guidelines for the use and interpretation of assays for monitoring autophagy in higher eukaryotes. *Autophagy* 4:151–75
4. Kroemer G, Mariño G, Levine B. 2010. Autophagy and the integrated stress response. *Mol. Cell* 40:280–93
5. Rabinowitz JD, White E. 2010. Autophagy and metabolism. *Science* 330:1344–48
6. Mizushima N, Yamamoto A, Matsui M, Yoshimori T, Ohsumi Y. 2004. In vivo analysis of autophagy in response to nutrient starvation using transgenic mice expressing a fluorescent autophagosome marker. *Mol. Biol. Cell* 15:1101–11
7. Kuma A, Hatano M, Matsui M, Yamamoto A, Nakaya H, et al. 2004. The role of autophagy during the early neonatal starvation period. *Nature* 432:1032–36
8. Komatsu M, Waguri S, Ueno T, Iwata J, Murata S, et al. 2005. Impairment of starvation-induced and constitutive autophagy in *Atg7*-deficient mice. *J. Cell Biol.* 169:425–34
9. Lum JJ, Bauer DE, Kong M, Harris MH, Li C, et al. 2005. Growth factor regulation of autophagy and cell survival in the absence of apoptosis. *Cell* 120:237–48
10. Roy S, Debnath J. 2010. Autophagy and tumorigenesis. *Semin. Immunopathol.* 32:383–96
11. Kim J, Kundu M, Viollet B, Guan KL. 2011. AMPK and mTOR regulate autophagy through direct phosphorylation of Ulk1. *Nat. Cell Biol.* 13:132–41
12. Hosokawa N, Hara T, Kaizuka T, Kishi C, Takamura A, et al. 2009. Nutrient-dependent mTORC1 association with the ULK1-Atg13-FIP200 complex required for autophagy. *Mol. Biol. Cell* 20:1981–91
13. Jung CH, Jun CB, Ro SH, Kim YM, Otto NM, et al. 2009. ULK-Atg13-FIP200 complexes mediate mTOR signaling to the autophagy machinery. *Mol. Biol. Cell* 20:1992–2003
14. Jung CH, Ro SH, Cao J, Otto NM, Kim DH. 2010. mTOR regulation of autophagy. *FEBS Lett.* 584:1287–95
15. Mihaylova MM, Shaw RJ. 2011. The AMPK signalling pathway coordinates cell growth, autophagy and metabolism. *Nat. Cell Biol.* 13:1016–23
16. Bellot G, Garcia-Medina R, Gounon P, Chiche J, Roux D, et al. 2009. Hypoxia-induced autophagy is mediated through hypoxia-inducible factor induction of BNIP3 and BNIP3L via their BH3 domains. *Mol. Cell Biol.* 29:2570–81
17. Delgado M, Singh S, De Haro S, Master S, Ponpuak M, et al. 2009. Autophagy and pattern recognition receptors in innate immunity. *Immunol. Rev.* 227:189–202
18. **Shi CS, Kehrl JH. 2008. MyD88 and TRIF target Beclin 1 to trigger autophagy in macrophages. *J. Biol. Chem.* 283:33175–82**
19. Shin DM, Yuk JM, Lee HM, Lee SH, Son JW, et al. 2010. Mycobacterial lipoprotein activates autophagy via TLR2/1/CD14 and a functional vitamin D receptor signalling. *Cell. Microbiol.* 12:1648–65
20. Kimmelman AC. 2011. The dynamic nature of autophagy in cancer. *Genes Dev.* 25:1999–2010
21. Gottlieb RA, Mentzer RM Jr. 2010. Autophagy during cardiac stress: joys and frustrations of autophagy. *Annu. Rev. Physiol.* 72:45–59
22. **Matsui Y, Takagi H, Qu X, Abdellatif M, Sakoda H, et al. 2007. Distinct roles of autophagy in the heart during ischemia and reperfusion. *Circ. Res.* 100:914–22**
23. Takagi H, Matsui Y, Hirotsani S, Sakoda H, Asano T, Sadoshima J. 2007. AMPK mediates autophagy during myocardial ischemia in vivo. *Autophagy* 3:405–7
24. **Hamacher-Brady A, Brady NR, Gottlieb RA. 2006. Enhancing macroautophagy protects against ischemia/reperfusion injury in cardiac myocytes. *J. Biol. Chem.* 281:29776–87**
25. Valentim L, Laurence KM, Townsend PA, Carroll CJ, Soond S, et al. 2006. Urocortin inhibits Beclin 1-mediated autophagic cell death in cardiac myocytes exposed to ischaemia/reperfusion injury. *J. Mol. Cell. Cardiol.* 40:846–52
26. Matsunaga K, Saitoh T, Tabata K, Omori H, Satoh T, et al. 2009. Two Beclin 1-binding proteins, Atg14L and Rubicon, reciprocally regulate autophagy at different stages. *Nat. Cell Biol.* 11:385–96
27. Zhong Y, Wang QJ, Li X, Yan Y, Backer JM, et al. 2009. Distinct regulation of autophagic activity by Atg14L and Rubicon associated with Beclin 1-phosphatidylinositol-3-kinase complex. *Nat. Cell Biol.* 11:468–76
28. Huang C, Yitzhaki S, Perry CN, Liu W, Giricz Z, et al. 2010. Autophagy induced by ischemic preconditioning is essential for cardioprotection. *J. Cardiovasc. Transl. Res.* 3:365–73

18. Identifies a direct mechanism for TLR-mediated autophagy induction via interaction between the TLR downstream effectors MyD88/TRIF and Beclin 1.

22, 24. Demonstrate that ischemia induces autophagy but that reperfusion leads to a severe block in autophagic flux.

29. Birmingham CL, Smith AC, Bakowski MA, Yoshimori T, Brumell JH. 2006. Autophagy controls *Salmonella* infection in response to damage to the *Salmonella*-containing vacuole. *J. Biol. Chem.* 281:11374–83
30. Orvedahl A, MacPherson S, Sumpter R Jr, Tallóczy Z, Zou Z, Levine B. 2010. Autophagy protects against *Sindbis virus* infection of the central nervous system. *Cell Host Microbe* 7:115–27
31. Yoshikawa Y, Ogawa M, Hain T, Yoshida M, Fukumatsu M, et al. 2009. *Listeria monocytogenes* ActA-mediated escape from autophagic recognition. *Nat. Cell Biol.* 11:1233–40
32. Ogawa M, Yoshimori T, Suzuki T, Sagara H, Mizushima N, Sasakawa C. 2005. Escape of intracellular *Shigella* from autophagy. *Science* 307:727–31
33. Gutierrez MG, Master SS, Singh SB, Taylor GA, Colombo MI, Deretic V. 2004. Autophagy is a defense mechanism inhibiting BCG and *Mycobacterium tuberculosis* survival in infected macrophages. *Cell* 119:753–66
34. Gutierrez MG, Vázquez CL, Munafó DB, Zoppino F, Berón W, et al. 2005. Autophagy induction favours the generation and maturation of the *Coxiella*-replicative vacuoles. *Cell. Microbiol.* 7:981–93
35. Xu Y, Jagannath C, Liu XD, Sharafkhaneh A, Kolodziejaska KE, Eissa NT. 2007. Toll-like receptor 4 is a sensor for autophagy associated with innate immunity. *Immunity* 27:135–44
36. Delgado MA, Elmaoued RA, Davis AS, Kyei G, Deretic V. 2008. Toll-like receptors control autophagy. *EMBO J.* 27:1110–21
37. Travassos LH, Carneiro LAM, Ramjeet M, Hussey S, Kim YG, et al. 2009. Nod1 and Nod2 direct autophagy by recruiting ATG16L1 to the plasma membrane at the site of bacterial entry. *Nat. Immunol.* 11:55–62
38. Kang R, Livesey KM, Zeh H, Loze MT, Tang D. 2010. HMGB1: a novel Beclin 1-binding protein active in autophagy. *Autophagy* 6:1209–11
39. Jounai N, Takeshita F, Kobiyama K, Sawano A, Miyawaki A, et al. 2007. The Atg5-Atg12 conjugate associates with innate antiviral immune responses. *Proc. Natl. Acad. Sci. USA* 104:14050–55
40. Kirkin V, Lamark T, Johansen T, Dikic I. 2009. NBR1 cooperates with p62 in selective autophagy of ubiquitinated targets. *Autophagy* 5:732–33
41. Kirkin V, Lamark T, Sou YS, Bjørkøy G, Nunn JL, et al. 2009. A role for NBR1 in autophagosomal degradation of ubiquitinated substrates. *Mol. Cell* 33:505–16
42. Pankiv S, Clausen TH, Lamark T, Brech A, Bruun JA, et al. 2007. p62/SQSTM1 binds directly to Atg8/LC3 to facilitate degradation of ubiquitinated protein aggregates by autophagy. *J. Biol. Chem.* 282:24131–45
43. Thurston TLM, Ryzhakov G, Bloor S, von Muhlinen N, Randow F. 2009. The TBK1 adaptor and autophagy receptor NDP52 restricts the proliferation of ubiquitin-coated bacteria. *Nat. Immunol.* 10:1215–21
44. Wild P, Farhan H, McEwan DG, Wagner S, Rogov VV, et al. 2011. Phosphorylation of the autophagy receptor optineurin restricts *Salmonella* growth. *Science* 333:228–33
45. Perrin AJ, Jiang X, Birmingham CL, So NSY, Brumell JH. 2004. Recognition of bacteria in the cytosol of mammalian cells by the ubiquitin system. *Curr. Biol.* 14:806–11
46. Dupont N, Lacas-Gervais S, Bertout J, Paz I, Freche B, et al. 2009. *Shigella* phagocytic vacuolar membrane remnants participate in the cellular response to pathogen invasion and are regulated by autophagy. *Cell Host Microbe* 6:137–49
47. Zheng YT, Shahnazari S, Brech A, Lamark T, Johansen T, Brumell JH. 2009. The adaptor protein p62/SQSTM1 targets invading bacteria to the autophagy pathway. *J. Immunol.* 183:5909–16
48. Ogawa M, Yoshikawa Y, Kobayashi T, Mimuro H, Fukumatsu M, et al. 2011. A Tecpr1-dependent selective autophagy pathway targets bacterial pathogens. *Cell Host Microbe* 9:376–89
49. Thurston TLM, Wandel MP, von Muhlinen N, Foeglein A, Randow F. 2012. Galectin 8 targets damaged vesicles for autophagy to defend cells against bacterial invasion. *Nature* 482:414–18
50. Nedjic J, Aichinger M, Emmerich J, Mizushima N, Klein L. 2008. Autophagy in thymic epithelium shapes the T cell repertoire and is essential for tolerance. *Nature* 455:396–400
51. Saitoh T, Fujita N, Jang MH, Uematsu S, Yang BG, et al. 2008. Loss of the autophagy protein Atg16L1 enhances endotoxin-induced IL-1 β production. *Nature* 456:264–68

52. Nakahira K, Haspel JA, Rathinam VAK, Lee SJ, Dolinay T, et al. 2010. Autophagy proteins regulate innate immune responses by inhibiting the release of mitochondrial DNA mediated by the NALP3 inflammasome. *Nat. Immunol.* 12:222–30
53. Dupont N, Jiang S, Pilli M, Ornatowski W, Bhattacharya D, Deretic V. 2011. Autophagy-based unconventional secretory pathway for extracellular delivery of IL-1 β . *EMBO J.* 30:4701–11
54. Manjithaya R, Subramani S. 2011. Autophagy: a broad role in unconventional protein secretion? *Trends Cell Biol.* 21:67–73
55. Cadwell K, Liu JY, Brown SL, Miyoshi H, Loh J, et al. 2008. A key role for autophagy and the autophagy gene *Atg16L1* in mouse and human intestinal Paneth cells. *Nature* 456:259–63
56. Sewell GW, Marks DJB, Segal AW. 2009. The immunopathogenesis of Crohn's disease: a three-stage model. *Curr. Opin. Immunol.* 21:506–13
57. Fritz T, Niederreiter L, Adolph T, Blumberg RS, Kaser A. 2011. Crohn's disease: NOD2, autophagy and ER stress converge. *Gut* 60:1580–88
58. Singh SB, Davis AS, Taylor GA, Deretic V. 2006. Human IRGM induces autophagy to eliminate intracellular mycobacteria. *Science* 313:1438–41
59. Cadwell K, Patel KK, Maloney NS, Liu TC, Ng ACY, et al. 2010. Virus-plus-susceptibility gene interaction determines Crohn's disease gene *Atg16L1* phenotypes in intestine. *Cell* 141:1135–45
60. Feng CG, Collazo-Custodio CM, Eckhaus M, Hieny S, Belkaid Y, et al. 2004. Mice deficient in LRG-47 display increased susceptibility to mycobacterial infection associated with the induction of lymphopenia. *J. Immunol.* 172:1163–68
61. Henry SC, Daniell X, Indaram M, Whitesides JF, Sempowski GD, et al. 2007. Impaired macrophage function underscores susceptibility to *Salmonella* in mice lacking *Irgm1* (LRG-47). *J. Immunol.* 179:6963–72
62. Cooney R, Baker J, Brain O, Danis B, Pichulik T, et al. 2009. NOD2 stimulation induces autophagy in dendritic cells influencing bacterial handling and antigen presentation. *Nat. Med.* 16:90–97
63. Kobayashi KS, Chamillard M, Ogura Y, Henegariu O, Inohara N, et al. 2005. Nod2-dependent regulation of innate and adaptive immunity in the intestinal tract. *Science* 307:731–34
64. Maeda S, Hsu LC, Liu H, Bankston LA, Iimura M, et al. 2005. Nod2 mutation in Crohn's disease potentiates NF- κ B activity and IL-1 β processing. *Science* 307:734–38
65. Homer CR, Richmond AL, Rebert NA, Achkar JP, McDonald C. 2010. ATG16L1 and NOD2 interact in an autophagy-dependent antibacterial pathway implicated in Crohn's disease pathogenesis. *Gastroenterology* 139:1630–41
66. Cadwell K, Patel KK, Komatsu M, Virgin HW IV, Stappenbeck TS. 2009. A common role for *Atg16L1*, *Atg5*, and *Atg7* in small intestinal Paneth cells and Crohn's disease. *Autophagy* 5:250–52
67. Kraft C, Peter M, Hofmann K. 2010. Selective autophagy: ubiquitin-mediated recognition and beyond. *Nat. Cell Biol.* 12:836–41
68. Ebato C, Uchida T, Arakawa M, Komatsu M, Ueno T, et al. 2008. Autophagy is important in islet homeostasis and compensatory increase of β -cell mass in response to high-fat diet. *Cell Metab.* 8:325–32
69. Jung HS, Chung KW, Won Kim J, Kim J, Komatsu M, et al. 2008. Loss of autophagy diminishes pancreatic β -cell mass and function with resultant hyperglycemia. *Cell Metab.* 8:318–24
70. Masiero E, Agatea L, Mammucari C, Blaauw B, Loro E, et al. 2009. Autophagy is required to maintain muscle mass. *Cell Metab.* 10:507–15
71. Nakai A, Yamaguchi O, Takeda T, Higuchi Y, Hikoso S, et al. 2007. The role of autophagy in cardiomyocytes in the basal state and in response to hemodynamic stress. *Nat. Med.* 13:619–24
72. Raben N, Hill V, Shea L, Takikita S, Baum R, et al. 2008. Suppression of autophagy in skeletal muscle uncovers the accumulation of ubiquitinated proteins and their potential role in muscle damage in Pompe disease. *Hum. Mol. Genet.* 17:3897–908
73. Hara T, Nakamura K, Matsui M, Yamamoto A, Nakahara Y, et al. 2006. Suppression of basal autophagy in neural cells causes neurodegenerative disease in mice. *Nature* 441:885–89
74. Komatsu M, Waguri S, Chiba T, Murata S, Iwata J, et al. 2006. Loss of autophagy in the central nervous system causes neurodegeneration in mice. *Nature* 441:880–84
75. Kawaguchi Y, Kovacs JJ, McLaurin A, Vance JM, Ito A, Yao TP. 2003. The deacetylase HDAC6 regulates aggresome formation and cell viability in response to misfolded protein stress. *Cell* 115:727–38
53. Identifies a role for autophagy in unconventional secretion in mammalian cells.
- 55, 59, 66. Confirm a role for autophagy in Crohn's disease pathogenesis and identify a novel environment-plus-susceptibility gene interaction.
67. Reviews the molecular mechanisms involved in selective autophagy, particularly the degradation of ubiquitinated substrates.
- 73, 74. Demonstrate the importance of basal autophagy in normal tissue homeostasis—in this case, in neurons.

76. Lee JY, Koga H, Kawaguchi Y, Tang W, Wong E, et al. 2010. HDAC6 controls autophagosome maturation essential for ubiquitin-selective quality-control autophagy. *EMBO J.* 29:969–80
77. Cheung ZH, Ip NY. 2011. Autophagy deregulation in neurodegenerative diseases—recent advances and future perspectives. *J. Neurochem.* 118:317–25
78. Ding WX, Ni HM, Li M, Liao Y, Chen X, et al. 2010. Nix is critical to two distinct phases of mitophagy, reactive oxygen species-mediated autophagy induction and Parkin-ubiquitin-p62-mediated mitochondrial priming. *J. Biol. Chem.* 285:27879–90
79. Novak I, Kirkin V, McEwan DG, Zhang J, Wild P, et al. 2009. Nix is a selective autophagy receptor for mitochondrial clearance. *EMBO Rep.* 11:45–51
80. Liu L, Feng D, Chen G, Chen M, Zheng Q, et al. 2012. Mitochondrial outer-membrane protein FUNDC1 mediates hypoxia-induced mitophagy in mammalian cells. *Nat. Cell Biol.* 14:177–85
81. Jin SM, Lazarou M, Wang C, Kane LA, Narendra DP, Youle RJ. 2010. Mitochondrial membrane potential regulates PINK1 import and proteolytic destabilization by PARL. *J. Cell Biol.* 191:933–42
82. Chan NC, Salazar AM, Pham AH, Sweredoski MJ, Kolawa NJ, et al. 2011. Broad activation of the ubiquitin-proteasome system by Parkin is critical for mitophagy. *Hum. Mol. Genet.* 20:1726–37
83. Matsuda N, Sato S, Shiba K, Okatsu K, Saisho K, et al. 2010. PINK1 stabilized by mitochondrial depolarization recruits Parkin to damaged mitochondria and activates latent Parkin for mitophagy. *J. Cell Biol.* 189:211–21
84. Narendra D, Tanaka A, Suen DF, Youle RJ. 2008. Parkin is recruited selectively to impaired mitochondria and promotes their autophagy. *J. Cell Biol.* 183:795–803
85. Narendra DP, Jin SM, Tanaka A, Suen DF, Gautier CA, et al. 2010. PINK1 is selectively stabilized on impaired mitochondria to activate Parkin. *PLoS Biol.* 8:e1000298
86. Vives-Bauza C, Zhou C, Huang Y, Cui M, de Vries RLA, et al. 2010. PINK1-dependent recruitment of Parkin to mitochondria in mitophagy. *Proc. Natl. Acad. Sci. USA* 107:378–83
87. Yoshii SR, Kishi C, Ishihara N, Mizushima N. 2011. Parkin mediates proteasome-dependent protein degradation and rupture of the outer mitochondrial membrane. *J. Biol. Chem.* 286:19630–40
88. Wang X, Winter D, Ashrafi G, Schlehe J, Wong YL, et al. 2011. PINK1 and Parkin target Miro for phosphorylation and degradation to arrest mitochondrial motility. *Cell* 147:893–906
- 89. Yang L, Li P, Fu S, Calay ES, Hotamisligil GS. 2010. Defective hepatic autophagy in obesity promotes ER stress and causes insulin resistance. *Cell Metab.* 11:467–78**
90. Shibata M, Lu T, Furuya T, Degtrev A, Mizushima N, et al. 2006. Regulation of intracellular accumulation of mutant Huntingtin by Beclin 1. *J. Biol. Chem.* 281:14474–85
91. Giasson BI, Duda JE, Quinn SM, Zhang B, Trojanowski JQ, Lee VMY. 2002. Neuronal α -synucleinopathy with severe movement disorder in mice expressing A53T human α -synuclein. *Neuron* 34:521–33
92. Cuervo AM, Stefanis L, Fredenburg R, Lansbury PT, Sulzer D. 2004. Impaired degradation of mutant α -synuclein by chaperone-mediated autophagy. *Science* 305:1292–95
93. Vogiatzi T, Xilouri M, Vekrellis K, Stefanis L. 2008. Wild type α -synuclein is degraded by chaperone-mediated autophagy and macroautophagy in neuronal cells. *J. Biol. Chem.* 283:23542–56
94. Webb JL, Ravikumar B, Atkins J, Skepper JN, Rubinsztein DC. 2003. α -Synuclein is degraded by both autophagy and the proteasome. *J. Biol. Chem.* 278:25009–13
95. Choubey V, Safiulina D, Vaarmann A, Cagalinec M, Wareski P, et al. 2011. Mutant A53T α -synuclein induces neuronal death by increasing mitochondrial autophagy. *J. Biol. Chem.* 286:10814–24
96. Wong ASL, Lee RHK, Cheung AY, Yeung PK, Chung SK, et al. 2011. Cdk5-mediated phosphorylation of endophilin B1 is required for induced autophagy in models of Parkinson's disease. *Nat. Cell Biol.* 13:568–79
97. Ross OA, Braithwaite AT, Skipper LM, Kachergus J, Hulihan MM, et al. 2008. Genomic investigation of α -synuclein multiplication and parkinsonism. *Ann. Neurol.* 63:743–50
98. Winslow AR, Chen CW, Corrochano S, Acevedo-Arozena A, Gordon DE, et al. 2010. α -Synuclein impairs macroautophagy: implications for Parkinson's disease. *J. Cell Biol.* 190:1023–37
99. Masliah E, Rockenstein E, Veinbergs I, Mallory M, Hashimoto M, et al. 2000. Dopaminergic loss and inclusion body formation in α -synuclein mice: implications for neurodegenerative disorders. *Science* 287:1265–69

100. Spencer B, Potkar R, Trejo M, Rockenstein E, Patrick C, et al. 2009. *Beclin1* gene transfer activates autophagy and ameliorates the neurodegenerative pathology in α -synuclein models of Parkinson's and Lewy body diseases. *J. Neurosci.* 29:13578–88
101. Kitada T, Asakawa S, Hattori N, Matsumine H, Yamamura Y, et al. 1998. Mutations in the *parkin* gene cause autosomal recessive juvenile parkinsonism. *Nature* 392:605–8
102. Valente EM, Abou-Sleiman PM, Caputo V, Muqit MMK, Harvey K, et al. 2004. Hereditary early-onset Parkinson's disease caused by mutations in *PINK1*. *Science* 304:1158–60
103. Geisler S, Holmström KM, Skujat D, Fiesel FC, Rothfuss OC, et al. 2010. PINK1/Parkin-mediated mitophagy is dependent on VDAC1 and p62/SQSTM1. *Nat. Cell Biol.* 12:119–31
104. Lee JY, Nagano Y, Taylor JP, Lim KL, Yao TP. 2010. Disease-causing mutations in Parkin impair mitochondrial ubiquitination, aggregation, and HDAC6-dependent mitophagy. *J. Cell Biol.* 189:671–79
105. Mortiboys H, Thomas KJ, Koopman WJH, Klaffke S, Abou-Sleiman P, et al. 2008. Mitochondrial function and morphology are impaired in *parkin*-mutant fibroblasts. *Ann. Neurol.* 64:555–65
106. Schapira A, Cooper J, Dexter D, Clark J, Jenner P, Marsden C. 1990. Mitochondrial complex I deficiency in Parkinson's disease. *J. Neurochem.* 54:823–27
107. Gautier CA, Kitada T, Shen J. 2008. Loss of *PINK1* causes mitochondrial functional defects and increased sensitivity to oxidative stress. *Proc. Natl. Acad. Sci. USA* 105:11364–69
108. Palacino JJ, Sagi D, Goldberg MS, Krauss S, Motz C, et al. 2004. Mitochondrial dysfunction and oxidative damage in *parkin*-deficient mice. *J. Biol. Chem.* 279:18614–22
109. Gispert S, Ricciardi F, Kurz A, Azizov M, Hoepken HH, et al. 2009. Parkinson phenotype in aged *PINK1*-deficient mice is accompanied by progressive mitochondrial dysfunction in absence of neurodegeneration. *PLoS ONE* 4:e5777
110. Lu XH, Fleming SM, Meurers B, Ackerson LC, Mortazavi F, et al. 2009. Bacterial artificial chromosome transgenic mice expressing a truncated mutant parkin exhibit age-dependent hypokinetic motor deficits, dopaminergic neuron degeneration, and accumulation of proteinase K-resistant α -synuclein. *J. Neurosci.* 29:1962–76
111. Zhu J, Horbinski C, Guo F, Watkins S, Uchiyama Y, Chu CT. 2007. Regulation of autophagy by extracellular signal-regulated protein kinases during 1-methyl-4-phenylpyridinium-induced cell death. *Am. J. Pathol.* 170:75–86
112. Dehay B, Bové J, Rodríguez-Muela N, Perier C, Recasens A, et al. 2010. Pathogenic lysosomal depletion in Parkinson's disease. *J. Neurosci.* 30:12535–44
113. Nixon RA, Wegiel J, Kumar A, Yu WH, Peterhoff C, et al. 2005. Extensive involvement of autophagy in Alzheimer disease: an immuno-electron microscopy study. *J. Neuropathol. Exp. Neurol.* 64:113–22
114. Lee JH, Yu WH, Kumar A, Lee S, Mohan PS, et al. 2010. Lysosomal proteolysis and autophagy require presenilin 1 and are disrupted by Alzheimer-related PS1 mutations. *Cell* 141:1146–58
115. Boland B, Kumar A, Lee S, Platt FM, Wegiel J, et al. 2008. Autophagy induction and autophagosome clearance in neurons: relationship to autophagic pathology in Alzheimer's disease. *J. Neurosci.* 28:6926–37
116. Yu WH, Cuervo AM, Kumar A, Peterhoff CM, Schmidt SD, et al. 2005. Macroautophagy—a novel β -amyloid peptide-generating pathway activated in Alzheimer's disease. *J. Cell Biol.* 171:87–98
117. Caccamo A, Majumder S, Richardson A, Strong R, Oddo S. 2010. Molecular interplay between mammalian target of rapamycin (mTOR), amyloid- β , and tau. *J. Biol. Chem.* 285:13107–20
118. Jaeger PA, Pickford F, Sun CH, Lucin KM, Masliah E, Wyss-Coray T. 2010. Regulation of amyloid precursor protein processing by the Beclin 1 complex. *PLoS ONE* 5:e11102
119. Pickford F, Masliah E, Britschgi M, Lucin K, Narasimhan R, et al. 2008. The autophagy-related protein beclin 1 shows reduced expression in early Alzheimer disease and regulates amyloid β accumulation in mice. *J. Clin. Investig.* 118:2190–99
120. Berger Z, Ravikumar B, Menzies FM, Oroz LG, Underwood BR, et al. 2006. Rapamycin alleviates toxicity of different aggregate-prone proteins. *Hum. Mol. Genet.* 15:433–42
121. Wang Y, Martinez-Vicente M, Krüger U, Kaushik S, Wong E, et al. 2009. Tau fragmentation, aggregation and clearance: the dual role of lysosomal processing. *Hum. Mol. Genet.* 18:4153–70
122. Hung SY, Huang WP, Liou HC, Fu WM. 2009. Autophagy protects neuron from A β -induced cytotoxicity. *Autophagy* 5:502–10

123. Wang H, Ma J, Tan Y, Wang Z, Sheng C, et al. 2010. Amyloid- β 1-42 induces reactive oxygen species-mediated autophagic cell death in U87 and SH-SY5Y cells. *J. Alzheimer Dis.* 21:597-610
124. Kegel KB, Kim M, Sapp E, McIntyre C, Castaño JG, et al. 2000. Huntingtin expression stimulates endosomal-lysosomal activity, endosome tubulation, and autophagy. *J. Neurosci.* 20:7268-78
125. Ravikumar B, Duden R, Rubinsztein DC. 2002. Aggregate-prone proteins with polyglutamine and polyalanine expansions are degraded by autophagy. *Hum. Mol. Genet.* 11:1107-17
126. Martinez-Vicente M, Talloczy Z, Wong E, Tang G, Koga H, et al. 2010. Cargo recognition failure is responsible for inefficient autophagy in Huntington's disease. *Nat. Neurosci.* 13:567-76
127. Ravikumar B, Vacher C, Berger Z, Davies JE, Luo S, et al. 2004. Inhibition of mTOR induces autophagy and reduces toxicity of polyglutamine expansions in fly and mouse models of Huntington disease. *Nat. Genet.* 36:585-95
128. Finn PF, Dice JF. 2006. Proteolytic and lipolytic responses to starvation. *Nutrition* 22:830-44
129. Wang X, Blagden C, Fan J, Nowak SJ, Taniuchi I, et al. 2005. Runx1 prevents wasting, myofibrillar disorganization, and autophagy of skeletal muscle. *Genes Dev.* 19:1715-22
130. Mammucari C, Milan G, Romanello V, Masiero E, Rudolf R, et al. 2007. FoxO3 controls autophagy in skeletal muscle in vivo. *Cell Metab.* 6:458-71
131. Kundu M, Thompson CB. 2008. Autophagy: basic principles and relevance to disease. *Annu. Rev. Pathol. Mech. Dis.* 3:427-55
132. Dobrowolny G, Aucello M, Rizzuto E, Beccafico S, Mammucari C, et al. 2008. Skeletal muscle is a primary target of SOD1^{G93A}-mediated toxicity. *Cell Metab.* 8:425-36
133. Vergne I, Roberts E, Elmaoued RA, Tosch V, Delgado MA, et al. 2009. Control of autophagy initiation by phosphoinositide-3-phosphatase Jumpy. *EMBO J.* 28:2244-58
134. Singh R, Kaushik S, Wang Y, Xiang Y, Novak I, et al. 2009. Autophagy regulates lipid metabolism. *Nature* 458:1131-35
135. Donohue TM Jr, McVicker DL, Kharbanda KK, Chaisson ML, Zetterman RK. 1994. Ethanol administration alters the proteolytic activity of hepatic lysosomes. *Alcohol. Clin. Exp. Res.* 18:536-41
136. Pösö A, Hirsimäki P. 1991. Inhibition of proteolysis in the liver by chronic ethanol feeding. *Biochem. J.* 273:149-52
137. Zatloukal K, Stumptner C, Fuchsbichler A, Heid H, Schnoelzer M, et al. 2002. p62 is a common component of cytoplasmic inclusions in protein aggregation diseases. *Am. J. Pathol.* 160:255-63
138. Harada M, Hanada S, Toivola DM, Ghori N, Omary MB. 2008. Autophagy activation by rapamycin eliminates mouse Mallory-Denk bodies and blocks their proteasome inhibitor-mediated formation. *Hepatology* 47:2026-35
139. Tomita K, Tamiya G, Ando S, Kitamura N, Koizumi H, et al. 2005. AICAR, an AMPK activator, has protective effects on alcohol-induced fatty liver in rats. *Alcohol. Clin. Exp. Res.* 29:240-45S
140. You M, Matsumoto M, Pacold CM, Cho WK, Crabb DW. 2004. The role of AMP-activated protein kinase in the action of ethanol in the liver. *Gastroenterology* 127:1798-808
141. Liu HY, Han J, Cao SY, Hong T, Zhuo D, et al. 2009. Hepatic autophagy is suppressed in the presence of insulin resistance and hyperinsulinemia. *J. Biol. Chem.* 284:31484-92
142. Wu JJ, Quijano C, Chen E, Liu H, Cao L, et al. 2009. Mitochondrial dysfunction and oxidative stress mediate the physiological impairment induced by the disruption of autophagy. *Aging* 1:425-37
143. Masini M, Bugliani M, Lupi R, Del Guerra S, Boggi U, et al. 2009. Autophagy in human type 2 diabetes pancreatic β -cells. *Diabetologia* 52:1083-86
144. Marsh BJ, Soden C, Alarcón C, Wicksteed BL, Yaekura K, et al. 2007. Regulated autophagy controls hormone content in secretory-deficient pancreatic endocrine β -cells. *Mol. Endocrinol.* 21:2255-69
145. Kaniuk NA, Kiraly M, Bates H, Vranic M, Volchuk A, Brumell JH. 2007. Ubiquitinated-protein aggregates form in pancreatic β -cells during diabetes-induced oxidative stress and are regulated by autophagy. *Diabetes* 56:930-39
146. Li X, Zhang L, Meshinchi S, Dias-Leme C, Raffin D, et al. 2006. Islet microvasculature in islet hyperplasia and failure in a model of type 2 diabetes. *Diabetes* 55:2965-73
147. Zhao Z, Fux B, Goodwin M, Dunay IR, Strong D, et al. 2008. Autophagosome-independent essential function for the autophagy protein Atg5 in cellular immunity to intracellular pathogens. *Cell Host Microbe* 4:458-69

148. Reggiori F, Monastyrska I, Verheije MH, Calč T, Ulasli M, et al. 2010. Coronaviruses hijack the LC3-I-positive EDEMosomes, ER-derived vesicles exporting short-lived ERAD regulators, for replication. *Cell Host Microbe* 7:500–8
149. Radoshevich L, Murrow L, Chen N, Fernandez E, Roy S, et al. 2010. ATG12 conjugation to ATG3 regulates mitochondrial homeostasis and cell death. *Cell* 142:590–600
150. Rubinstein AD, Eisenstein M, Ber Y, Bialik S, Kimchi A. 2011. The autophagy protein Atg12 associates with antiapoptotic Bcl-2 family members to promote mitochondrial apoptosis. *Mol. Cell* 44:698–709

Published in final edited form as:

Adv Exp Med Biol. 2013 ; 734: 73–89. doi:10.1007/978-1-4614-1445-2_5.

Regulation of Tumor Cell Dormancy by Tissue Microenvironments and Autophagy

Maria Soledad Sosa, PhD,

Departments of Medicine and Otolaryngology, Tisch Cancer Institute, Black Family Stem Cell Institute, Mount Sinai School of Medicine, New York, NY, USA

Paloma Bragado, PhD,

Departments of Medicine and Otolaryngology, Tisch Cancer Institute, Black Family Stem Cell Institute, Mount Sinai School of Medicine, New York, NY, USA

Jayanta Debnath, MD, and

Department of Pathology, Helen Diller Family Comprehensive Cancer Center, University of California San Francisco, San Francisco, CA, USA

Julio A. Aguirre-Ghiso, PhD

Departments of Medicine and Otolaryngology, Tisch Cancer Institute, Black Family Stem Cell Institute, Mount Sinai School of Medicine, New York, NY, USA

Julio A. Aguirre-Ghiso: julio.aguirre-ghiso@mssm.edu

Abstract

The development of metastasis is the major cause of death in cancer patients. In certain instances, this occurs shortly after primary tumor detection and treatment, indicating these lesions were already expanding at the moment of diagnosis or initiated exponential growth shortly after. However, in many types of cancer, patients succumb to metastatic disease years and sometimes decades after being treated for a primary tumor. This has led to the notion that in these patients residual disease may remain in a dormant state. Tumor cell dormancy is a poorly understood phase of cancer progression and only recently have its underlying molecular mechanisms started to be revealed. Important questions that remain to be elucidated include not only which mechanisms prevent residual disease from proliferating but also which mechanisms critically maintain the long-term survival of these disseminated residual cells. Herein, we review recent evidence in support of genetic and epigenetic mechanisms driving dormancy. We also explore how therapy may cause the onset of dormancy in the surviving fraction of cells after treatment and how autophagy may be a mechanism that maintains the residual cells that are viable for prolonged periods.

Keywords

Quiescence; Minimal residual disease; Cellular stress; p38; MAPK; Metastasis

Introduction

Metastasis is responsible for the majority of cancer-related deaths. However, our understanding of this complex process is incomplete, which limits our opportunities to

prevent metastatic development. There are several fundamental questions that remain mostly unanswered in this field: How does early dissemination contribute to a dormant cell population and what are the underlying mechanisms? How does the tumor microenvironment aid this process? Are primary tumor niches responsible for programming disseminated tumor cells (DTCs) to grow or enter quiescence in target organs? What role does the microenvironment of the target organ play in determining the timing or extent of DTC dormancy?

The “seed and soil” theory of metastasis proposes that a natural match exists between the DTCs (the seeds) and the target organ (the soil) in which they can grow into overt lesions [1]. This theory is derived from the relatively predictable pattern of target organ metastasis that depends on the tissue origin of the primary tumor. However, it remains difficult to predict the timing of metastasis because, even in those sites propitious for growth, it can take years to decades for metastases to develop [1]. Indeed, certain cancers, such as breast carcinoma and melanoma, are well known for their propensity to relapse after a long disease-free period, often decades after initial diagnosis and treatment of the primary tumor. Moreover, it has been proposed that these long periods of asymptomatic disease are due to minimal residual disease (MRD), because DTCs enter a nonproductive or dormant state [1, 2].

In cancer patients, DTCs can be found in sites where they typically form secondary lesions, as well as in sites where they rarely do [1]. Thus, despite being able to disseminate, these DTCs are presumably “growth-suppressed” by the microenvironments of certain organs. Insights into these mechanisms should lead to the identification of novel biomarkers that indicate whether patients harbor dormant disease, and should uncover new signaling pathways that can be modulated to either maintain the dormancy of DTCs or eliminate them entirely by blocking critical survival pathways.

To date, several mechanisms have been proposed to explain clinical dormancy (i.e., asymptomatic disease) in cancers. The lack of proliferation markers in surviving DTCs obtained from patients and findings from experimental studies suggest that solitary DTC dormancy may be controlled by mechanisms of quiescence [1], a reversible growth arrest that can be induced by different signals [3]. Angiogenic dormancy or immune system-mediated tumor mass dormancy may also be responsible for maintaining the dormancy of residual disease [4, 5] (see Almog and Quesnel chapters in this book).

The primary tumor and target organ microenvironments are intimately interconnected by the biology of DTCs (Fig. 5.1). Three potential scenarios that relate to this concept may explain DTC dormancy. First, DTCs from invasive cancers activate stress signals in response to the dissemination process and/or due to a growth-suppressive microenvironment of the target organ (see “The Target Organ Microenvironment and DTC Dormancy” section for examples of such microenvironments and their components), ultimately leading to induction of dormancy [1]. Second, therapy and/or microenvironmental stress conditions (e.g., hypoxia, reactive oxygen species) acting on tumor cells in the primary lesion endow these tumor cells with specific gene expression signatures that prime newly formed DTCs to enter dormancy. Here, specific primary tumor “stress microenvironments” may influence the DTCs to enter long-term dormancy when the cells initially arrive at secondary sites. Third, lesions that are pathologically defined as noninvasive carry a subpopulation of cells that possess the ability to undergo micro-invasion and disseminate. Although these DTCs are able to intravasate into and extravasate out of the systemic circulation, they remain unfit for expansion in secondary sites. Nonetheless, they can survive in an arrested state over an extended period and perhaps undergo occasional cell divisions, progressing via epigenetic and genetic pathways to eventually become a fully metastatic cell able to grow at the secondary sites. In

this chapter, we focus both on how solitary DTC fate is influenced by tumor–host interactions occurring in primary tumors and target organs, and on how autophagy may serve as a cell-autonomous survival function in residual disease (Fig. 5.2). We propose that DTCs undergo dormancy to survive specific stressful microenvironments (see section “The Target Organ Microenvironment and DTC Dormancy”) and, therefore, that blockade of the survival signals in dormant cells will ultimately lead to their eradication.

Early Dissemination as a Contributing Factor to Dormancy and MRD

The present paradigm proposes that metastases arise from rare clones that evolve in the primary tumor and acquire characteristics that allow them to disseminate and grow in secondary sites [6, 7]. This somewhat linear model motivates the prediction that tumor cells will emerge with metastatic capacity only if they are derived from evolutionarily “late-progressed” tumors (i.e., those with multiple malignancy-associated genetic alterations). It also suggests that tumor cells endowed with metastatic capacity should be absent or infrequent in patients carrying premalignant/invasive lesions (with fewer genetic alterations, see below) [6, 7]. However, a major challenge to this theory was posed by a series of studies in breast cancer from the Klein lab, which suggested that dissemination had already occurred in lesions that were considered to develop “early” in tumor progression and were pathologically defined as noninvasive, such as atypical ductal hyperplasia (ADH) and ductal carcinoma in situ (DCIS) [6, 8–11]. These studies also indicated that the pause observed in the progression of early DTCs may be due to a “lead time” [6, 8–11]. This refers to the time when DTCs with a limited number of genetic alterations are able to survive, but are unable to efficiently proliferate to gain additional mutations that would favor growth ectopically. This is supported by the fact that genetic alterations in DTCs detected in patients with ADH or DCIS are very heterogeneous [12]. In contrast, genetic anomalies in DTCs from patients carrying diagnosed metastatic disease are significantly more homogeneous, suggesting that certain genetic traits are selected for active expansion in the secondary site and that the original heterogeneity in DTCs is reduced [6, 8–12].

Modeling of tumor cell dissemination during early stages of cancer progression in MMTV-Neu (Neu) mice showed that premalignant lesions contained micro-invasive cells and that dissemination to lungs and bone marrow (BM) was readily detected [9]. In uveal melanoma, a cancer with 50% incidence of late liver recurrence (>10 years) in humans [13], analysis of tumor doubling times led to the conclusion that dissemination had occurred at least half a decade before diagnosis. In an uveal melanoma mouse model [14], it was shown that dissemination occurred early and dormant (i.e., growth-arrested) DTCs were commonplace. In a *Drosophila melanogaster* model using CSK (C-terminal Src kinase)-null flies, early dissemination required Src activation without loss of E-cadherin or obvious induction of an epithelial-mesenchymal transition, which is supposedly a prerequisite for dissemination [15].

It is possible that early dissemination accounts for the variable periods of dormancy time because early DTCs are genetically and/or epigenetically unfit for expansion. Alternatively, DTCs carrying genetic alterations that favor growth or those originating from more progressed lesions may be kept “in-check” by the microenvironment, whereby epigenetic or therapy-derived mechanisms [1] contribute to tumor cell dormancy during or after the “lead time” [1, 16]. In support of the microenvironment playing a role, a recent report suggested that breast cancer patients with cells disseminated to the BM had longer disease-free periods than patients who were negative for cells in this site [17]. This suggests that the bone microenvironment may change the timing of cancer progression by favoring dormancy. Nonetheless, it remains unclear how the primary tumor or the target organ

microenvironments may control the lead time in solitary DTCs, and the kinetics driving genetic progression during this lead time remain poorly understood.

The possibility of therapy-induced quiescence may follow different mechanisms. In multiple myeloma, treatment with a proteasome inhibitor (bortezomib) has been found to induce post treatment protracted quiescence and survival of a fraction of cancer cells [18]. Furthermore, it has been shown that BCR-ABL blasts detected by fluorescence in situ hybridization (FISH) in chronic myelogenous leukemia patients who had responded to interferon- γ treatment 5–10 years earlier had no detectable mRNA for the oncogene [19, 20]. This suggests that epigenetic or post-transcriptional mechanisms may be dominant and suppress gene expression, including even those genes that are mutated or amplified. This potentially explains why, despite the presence of genetic alterations, these cells remain at a residual level. This dormancy may be explained by mechanisms similar to those controlling hematopoietic stem cell dormancy, whereby inactive STAT1 and Akt1 as well as low Sca-1 levels apparently maintain dormancy of these cells. In fact, it has been proposed that treatment with interferon- α may break the dormancy of leukemic stem cells by activating (activity and expression) the above-mentioned molecules, and that these cells are now prone to being targeted by BCR-ABL inhibitors [21]. This also suggests that, while chemotherapeutic drugs or other treatments kill a large fraction of cells, they can also cause induction of a residual dormant cell population that may subsequently be poised for recurrence (see below).

The Target Organ Microenvironment and DTC Dormancy

Solitary DTCs in target organs can establish interactions with the extracellular matrix (ECM), immune cells, and vasculature [22]. Studies using breast cancer cell lines selected for vigorous growth in target organs identified gene expression profiles that favored organ-specific colonization [23]. On the contrary, some genes including the metastasis suppressor gene (MSG) *MKK4*, via *p38*, can suppress metastases [24], and this seems to depend on stress signals from the microenvironment (see Fig. 5.1) [25]. *MKK4* belongs to a family of genes that selectively blocks metastatic growth, and includes *KISS1*, *MKK6*, *BHLHLB3/Sharp-1* (another *p38*-induced gene [26]), and *Nm23-H1*, among others [25, 27]. Because these genes suppress the growth and expansion of DTCs at target organs, yet fail to impede primary tumor growth, this further supports that the target organs with specific tissue microenvironments are required for these molecules to exert their growth-suppressing functions.

In squamous carcinoma cells (HEp3), reduced expression of urokinase (uPA) receptor (uPAR) deactivates $\alpha 5\beta 1$ integrins, which makes these cells incapable of binding efficiently to fibronectin [28]. This results in reduced focal adhesion kinase (FAK) and epidermal growth factor receptor signaling, as well as in *p38* activation. Thus, a failure by tumor cells to establish appropriate interactions with the ECM may induce growth-restrictive signals that fuel a quiescence state [1]. Furthermore, the loss of $\beta 1$ integrin or FAK signaling in breast cancer models can induce dormancy, and activation of the Src-MLKC pathway can prevent dormancy [1, 29]. In addition, a fibrous collagen-I-enriched microenvironment in lungs can trigger intravenously injected mouse breast cancer cells to exit dormancy [29]. In contrast, microenvironments rich in fibrillar collagen-I induce melanoma quiescence by activating the discoidin domain receptor 2 and *p15INK4b* induction [13]. Collectively, these studies demonstrate that the loss of growth pathways induced by either therapies or a restrictive (i.e., fibrotic or non-fibrotic target tissues depending on the tumor type) tissue microenvironment is accompanied by the activation of stress pathways; this immediately motivates the hypothesis that the integration of these two types of signals within a DTC is responsible for both entry into and exit from a dormant state (see Fig. 5.1).

In HEP3 squamous carcinoma cells, while the activation of p38 α / β inhibits ERK1/2 signaling, it also activates a stress-adaptive response known as the unfolded protein response (UPR) [26, 30, 31]. These signals lead to an epigenetic reprogramming and induction of survival and quiescence of dormant HEP3 (D-HEP3) cells [32]. D-HEP3 cells inoculated in vivo enter a deep G₀–G₁ arrest characterized by induction of *p21*, *p27*, *p18*, and *p15* [26]. At least three transcription factors (TFs), p53, BHLHB3/41/Sharp1 and NR2F1, are regulated by p38 α / β and required for dormancy of tumor cells in vivo [26]. This program is activated in dormant DTCs recovered from the bone marrow (BM) but is reversed when tumor cells exit dormancy or grow persistently in lungs (our unpublished results) (see Fig. 5.1). BM-derived dormant HEP3 cells display a low ERK/p38 signaling ratio and induction of BHLHB3/41/Sharp-1, NR2F1, and p53. Interestingly, MSGs, such as *MKK4* and *MKK6*, are upstream activators of *p38* [25], whereas BHLHB3 is a target of *p38* required for quiescence induction [26]. Thus, it seems that different mechanisms converge in the regulation of the ERK/p38 signaling ratio and result in induction of either proliferation or dormancy.

An important question is whether the target organ microenvironment, where DTCs reside, induces dormancy programs, and if so, how? In tumors like those in head and neck squamous cell carcinoma and breast cancer, bone metastasis occurs at a frequency of 10–30% [7, 33, 34]. However, the detection of BM DTCs is much higher (>50% of patients) [6, 35]. This suggests that not all DTCs ultimately form overt metastasis and/or that a delay takes place. In mouse models of cancer (xenografts or transgenic), BM metastases are rarely observed. For example, in MMTV-Neu transgenic mice, BM DTCs are readily detected but mice never develop bone metastasis [9]. However, if the BM microenvironment is modified via irradiation [9] or if p38 α / β is systemically inhibited, then DTCs expand ([9] and our unpublished data). Thus, in certain organs, restrictive signals mediated at least by p38 α / β signaling can prevent occult DTCs from expanding.

In the search for signaling mediators that play a role in dormancy of DTCs in the BM, transforming growth factor-beta (TGF β), a cytokine rich in the BM microenvironment [36–39], has emerged as a potential factor. Although tumors have been shown to depend on TGF β to metastasize [40, 41], this ligand, depending on the degree of progression of tumors, can also be a potent inhibitor of epithelial tumor cell proliferation [42, 43]. TGF β is also required to maintain the quiescence of stem cells and progenitors in the BM [36–39]. Thus, some tumors may remain sensitive to TGF β growth inhibition in microenvironments where this factor is present (i.e., BM) [44]. In early-stage melanoma, TGF β is anti-proliferative, thus functioning as a tumor-suppressor, but in advanced melanoma it is pro-invasive [45–47]. How these two opposing scenarios develop is not entirely clear [45, 48]. Furthermore, there is clinical evidence of early spread of uveal melanoma and, in a smaller proportion of patients, cutaneous melanoma thinner than 0.76 mm in depth [49–51]. It is possible that, similar to early dissemination in breast cancer [10], melanoma may spread before the conversion from TGF β -inhibitory phenotype to pro-invasive behavior is activated, and when single cells arrive at distant sites, such as the liver or BM [9], they may remain in cell cycle arrest for prolonged periods due to high levels of and/or high responsiveness to TGF β .

ER-Stress Signaling Pathways Contribute to Growth Arrest and Survival Programs During Tumor Cell Dormancy

While exploring the mechanisms that drive quiescence and survival of dormant HEP3 cells, the Aguirre-Ghiso lab discovered that HEP3 cells display a high ERK1/2 to p38 α / β signaling ratio that favors proliferation in vivo [52–54]. The reprogramming of cells into dormancy (D-HEP3 cells) results in a reversion of this ratio, and now p38 signaling predominates over ERK. In addition, p38 appears to activate a negative feedback loop [28,

55, 56]. Using proteomics and microarray studies, the same group revealed that D-HEp3 cells develop an UPR characterized by enhanced endoplasmic reticulum (ER) signaling (see Fig. 5.1). In fact, all three arms of the UPR—ATF6 α , IRE1 α , and PERK—are activated in these cells [30, 31, 57, 58]. These studies led to the discovery that, in addition to inducing growth arrest, dormant cells utilized these signals to robustly withstand stress insults and survive *in vivo* for months. Among the three ER transmembrane signaling molecules, only PERK was found to contribute to the quiescence of D-HEp3 cells [30, 31, 57, 58]. It did so by attenuating translation initiation, which resulted in the downregulation of cyclin D1/D3 and CDK4 in these cells [30]. In fact, inducible activation of PERK signaling using a dimerizable Fv2E-PERK fusion protein and the divalent ligand AP20187 was sufficient to fully abrogate tumorigenicity and induce growth arrest, in some cases irreversibly [30]. PERK also contributes survival signals for D-HEp3 cells. In fact, inhibition of PERK made these cells susceptible to both glucose deprivation and chemotherapeutic drug-induced killing (see Fig. 5.1) [30, 31].

The other arms of the ER-stress pathways, ATF6 α and IRE1 α , were also found to regulate tumor cell dormancy by promoting survival and adaptation to the *in vivo* microenvironment [57]. RNA interference (RNAi)-mediated targeting of ATF6 α caused a decrease in the number of viable D-HEp3 cells *in vivo* without interrupting their dormancy [57]. RNAi targeting of XBP-1, a transcription factor (TF) that is exclusively activated by IRE1 α through noncanonical splicing, also induced dormant D-HEp3 cell killing [57] (and unpublished results). Neither RNAi to ATF6 α or XBP-1 affected the tumorigenicity of T-HEp3 cells. Thus, the survival capacity of these genes seems to operate primarily in the cells that enter quiescence and not in the proliferative counterpart (see Fig. 5.1).

The mechanism of survival for ATF6 α has also been explored in more detail. It has been shown the basal survival capacity of D-HEp3 cells to adapt and enter dormancy *in vivo* is not mediated by classical target genes regulated by ATF6 α during the UPR, including genes for the chaperone BiP/Grp78, secretogranin II, and a glucose transporter [57]. We found that ATF6 α induced Rheb, a small GTPase of the Ras family that directly activates the survival protein mTOR. Indeed, analysis of the mechanisms revealed that p38-dependent activation of ATF6 α results in Rheb induction and stronger activation of mTOR \rightarrow P-S6K \rightarrow P-S6 signaling [57]. This pathway confers only dormant cells with resistance to rapamycin, as RNAi targeting of Rheb or ATF6 restored sensitivity to the mTOR inhibitor. Most importantly, dormant D-HEp3 cells can no longer adapt to the *in vivo* microenvironment and die at least in part through a caspase-3-dependent apoptotic pathway (see Fig. 5.1) [57].

Moreover, p38 also induced the expression of the chaperone BiP/Grp78 (see Fig. 5.1). This chaperone is induced during ER-stress and is an essential survival factor as it is a primary regulator of protein folding in the ER lumen. Numerous studies have shown that BiP serves as a survival factor not only in response to ER-stress but also to other damaging agents, such as chemotherapeutic drugs [31]. The upregulation of BiP in dormant HEp3 cells and its induction by p38 suggests that p38 signaling, like ATF6 activation, could tap into BiP function to provide survival signals [31]. However, as mentioned above, BiP did not provide a survival advantage for basal *in vivo* adaptation [57], which raises the possibility that BiP may only protect dormant cells under extreme damaging conditions such as those encountered during chemotherapy [31]. In fact, it has been demonstrated that dormant D-HEp3 cells were inherently resistant to chemotherapy compared with their tumorigenic counterpart, and that this was not due to enhanced expression of ATP-binding cassette transporters [31]. Furthermore, RNAi targeting of BiP greatly sensitized dormant D-HEp3 cells to etoposide and doxorubicin treatment. In contrast, the lower levels of BiP in the T-HEp3 cells, when further decreased by RNAi, had no effect on the sensitivity of these cells to chemotherapy. Analysis of the mechanism revealed that BiP inhibited the activation of

the pro-apoptotic factor Bax [31]. Recent follow-up on our studies by other investigators revealed that in fact BiP inhibits Bax by regulating its inhibitor Bik (see Fig. 5.1) [59].

These studies highlight a mostly overlooked aspect of dormancy: cells, from either early primary lesions or more advanced tumors, must survive for prolonged periods before resuming growth. Our results suggest that there may be mechanisms that selectively protect quiescent cells from a hostile microenvironment or from stress imposed by the therapies used to treat different cancers. This may be an evolutionary conserved response to stress. For example, organisms like *Caenorhabditis elegans* are able to pause development and enter a dormant dauer stage in response to nutritional stress or oxidative stress derived from the environment [1, 60–62]. Numerous studies in yeast also suggest that stress signaling and induction of quiescent growth are coupled with the induction of survival pathways that protect the organism from stress conditions during growth arrest [63]. This prompts the question of whether these mechanisms are active in DTCs in patients and whether they can be exploited therapeutically.

Autophagy and Survival of Residual Disease

With increasing scrutiny on how fundamental cellular stress-response pathways impact survival and expansion of dormant tumor cells, autophagy has emerged as an attractive target against dormant tumor cells (see Fig. 5.2). Importantly, multiple routes of autophagic degradation exist within cells, including: (1) macroautophagy, in which cytoplasmic contents are sequestered in double membrane autophagosomes and subsequently delivered to the lysosome; (2) microautophagy, where cytoplasm is directly engulfed by the lysosomal membrane; and (3) chaperone-mediated autophagy, where proteins with a specific signal sequence are transported to the lysosomal lumen by a receptor-mediated process [64]. Of these routes, macroautophagy (hereafter called autophagy) has been most extensively studied for its potential functions in cancer. Macroautophagy is tightly regulated by a limited number of highly conserved genes called *ATGs* (*AuTophagy*-related genes), which were originally identified in yeast [65]. These landmark studies have led to numerous recent breakthroughs in mammals, demonstrating a critical role for autophagy in both physiological and pathological processes, including cancer initiation and progression [64].

The bulk degradation of cellular material through autophagy allows cells to recycle both nutrients and energy during starvation and stress; in this regard, autophagy is proposed to function as a fitness mechanism that allows tumor cells to survive provided the offending stressor is removed in a timely manner [66, 67]. This indispensable contribution of autophagy as a stress-response mechanism is poignantly illustrated by studies in mice, in which the genetic deletion of critical *ATGs* results in neonatal lethality within a day of birth [68, 69]. A potential role for autophagy in dormancy was originally broached in *C. elegans* during dauer diapause, a stress-induced, dormancy-like state that occurs when larvae are exposed to hostile environments [70]. Notably, in this model, defective autophagy (achieved via RNAi against multiple *ATGs*) potentially compromised survival during dauer, implying a conserved mechanism by which autophagy promotes survival during quiescent states [70]. Since autophagy is activated in response to various microenvironmental stresses implicated in tumor dormancy, including the UPR (ER-stress), hypoxia, and ECM detachment, an important outstanding issue is how autophagy impacts the survival, as well as the maintenance of the quiescent state, in dormant tumor cells.

Studies in breast cancer models suggest that decreased mitogenic signaling resulting from impaired integrin and growth factor signaling facilitates tumor dormancy [71, 72]. Specifically, suppression of $\beta 1$ -integrin signaling induces dormancy in the MMTV-PyMT model of breast cancer and squamous carcinoma [28, 72]. Thus, it is possible that, because

DTCs cannot efficiently engage a foreign ECM, impaired integrin signaling may stimulate autophagy for survival and maintenance of the dormant state. Consistent with this hypothesis, β 1-integrin signaling blockade is a potent inducer of autophagy in ECM-detached cells, and autophagy protects cells from detachment-induced apoptosis (anoikis) (see Fig. 5.2) [73]. Moreover, autophagy may contribute to the ability of solitary dormant cells to resist extrinsic apoptotic stimuli. In breast cancer metastases to bone, where DTCs remain dormant in the BM for extended periods of time, the tissue necrosis factor (TNF) ligand TRAIL is abundantly expressed in the BM microenvironment and can kill tumor cells; nonetheless, mechanisms involving Src-mediated TRAIL resistance promote the survival of indolent cells in the BM [74]. Because autophagy can protect cells from TRAIL-induced apoptosis, one can speculate that autophagy may similarly promote the survival of dormant cells in the BM [75, 76]. Interestingly, we found that D-HEp3 cells have constitutively higher levels of autophagy, as measured by green fluorescence protein-tagged LC3 and endogenous LC3 incorporation into autophagosomes, as well as elevated expression of specific autophagy-regulating genes including *ATG6*, *ATG7*, and *ATG8* (unpublished results). Our ongoing studies also reveal that ATF6, but not PERK, is responsible for LC3 processing into autophagosomes.

Recently, autophagy has been shown to be crucial for the survival of dormant cells in models of ovarian cancer and gastrointestinal stromal tumor (GIST) [77, 78]. The tumor suppressor aplasia Ras homolog member I (*ARHI*) is downregulated in over 60% of ovarian cancers and the re-expression of *ARHI* in a variety of human ovarian cancer cell lines induces autophagy (see Fig. 5.2). In xenograft ovarian tumors, *ARHI* overexpression promotes the formation of dormant tumors, which correlates with an increased level of autophagosome formation; accordingly, when *ARHI* expression is subsequently reduced, the tumor regains proliferative potential and rapidly re-grows. However, upon treatment of *ARHI*-induced dormant tumors with the lysosomal inhibitor chloroquine, this regrowth is dramatically reduced, suggesting that autophagy contributes to survival during *ARHI*-induced dormancy [77].

Another demonstration of autophagy as a survival pathway in quiescent cells comes from studies of GIST, the first solid tumor to be treated successfully with the small-molecule tyrosine kinase inhibitor imatinib mesylate (Gleevec) (see Fig. 5.2) [78]. However, less than 5% of GISTs regress significantly upon Gleevec treatment; rather, in the vast majority of patients, tumor cells indefinitely remain in a dormant, quiescent state in the presence of imatinib. Recent work indicates that this dormant state, termed stable disease, is closely associated with the induction of autophagy in response to imatinib. Upon inhibiting autophagy using RNAi-mediated *ATG* depletion or antimalarials, such as hydroxychloroquine and quinacrine, GIST cells undergo high levels of apoptosis both in vitro and in vivo. Thus, autophagy appears critical for the establishment of a dormant state in which GIST cells can survive indefinitely [78]. Moreover, these results in GIST broach the exciting idea that autophagy can be more widely exploited to kill or prevent the expansion of quiescent or dormant cancer cells, which are notorious for their resistance to both conventional and targeted therapies [79].

Tumor dormancy is also postulated to be a stress-management mechanism adopted by DTCs to cope with an unfavorable microenvironment by completely withdrawing from the cell cycle [1]. p27^{Kip1}, the cyclin-dependent kinase inhibitor involved in G₀/G₁ cell cycle arrest, was identified as a downstream target of the energy-sensing LKB1-AMPK pathway, as well as shown to induce autophagy and facilitate cell survival in response to growth factor withdrawal and metabolic stress (see Fig. 5.2) [80]. Thus, DTCs may depend on p27-mediated autophagy to survive in an inhospitable microenvironment and to resist chemotherapy. HEp3 cells in which p38 signaling induces dormancy also have induced

strong expression of p27 during their prolonged dormancy, further supporting this notion [26]. However, the exact biological role for autophagy during quiescence remains largely unknown; if autophagy promotes growth suppression in quiescent cells, one can alternatively hypothesize that it may limit the outgrowth of dormant cells into frank macrometastases. These questions are important, and it will be critical to determine whether autophagy plays a quiescence or survival-inducing role (or both) in quiescent DTCs. If autophagy induces a pro-survival state then strategies to block it could eradicate DTCs. In the case that it contributes to both quiescence and survival, then more detailed mechanistic analysis of these pathways will be required to reveal ways to block only the survival signals without interrupting quiescence.

Overall, these results motivate future work, especially those using in vivo pre-clinical models, to assess how autophagy influences the quiescence and/or survival and biological behavior of dormant breast cancer cells, and specifically whether autophagy inhibition can be exploited to prevent the development of macrometastases in cancer patients.

Concluding Remarks

Our knowledge on how the biology and genetics of DTCs influence dormancy and progression of metastasis remains limited. Many open questions still exist, which will likely become central themes in the future. For example, how is DTC fate affected by the primary tumor microenvironment, how do therapies applied to patients affect DTCs, and how do the target organs condition these responses? If DTCs are indeed the “seeds” of metastases, it will be imperative to directly investigate these questions by analyzing DTCs from patients. Importantly, an analysis of DTCs that survive therapy of the primary tumor will inform us on how these treatments, as well as target organs, impact adaptation and/or selection of subsequent recurrent metastatic disease. For example, the demonstration that DTCs undergo autophagy or tap into UPR survival signals to survive and persist for prolonged periods will be a promising finding that will motivate clinical trials targeting specific components of the autophagy or UPR machinery to eradicate these cells (i.e., maintenance therapy). Studies on dormancy may also yield information on how to maintain signals that propel quiescence, such as a combination of MEK inhibitors and agonists that mimic p38 α / β activation. A deeper understanding of the signals that maintain dormancy may lead to the identification of drugs that should be avoided in patients because of their potential to break this state, and thus, enhance disease progression. Although the study of DTCs and dormant disease is difficult, unraveling the inherent complexity of this poorly understood step of metastasis biology should profoundly impact cancer patients.

Acknowledgments

This work is supported by grants from the Samuel Waxman Cancer Research Foundation Tumor Dormancy Program, NIH/National Cancer Institute (CA109182, CA163131), NIEHS (ES017146), and NYSTEM to J.A.A.-G, DoD Breast Cancer Postdoctoral Fellowship to M.S.S. and NIH RO1 CA126792, CA126792-S1 (ARRA), and a DOD BCRP Era of Hope Scholar Award (W81XWH-11-1-0310) to J.D.

References

1. Aguirre-Ghiso JA. Models, mechanisms and clinical evidence for cancer dormancy. *Nat Rev Cancer*. 2007; 7:834–846. [PubMed: 17957189]
2. Klein CA. Framework models of tumor dormancy from patient-derived observations. *Curr Opin Genet Dev*. 2011; 21(1):42–49. [PubMed: 21145726]
3. Sang L, Collier HA, Roberts JM. Control of the reversibility of cellular quiescence by the transcriptional repressor HES1. *Science*. 2008; 321:1095–1100. [PubMed: 18719287]

4. Almog N, Ma L, Raychowdhury R, Schwager C, Erber R, Short S, et al. Transcriptional switch of dormant tumors to fast-growing angiogenic phenotype. *Cancer Res.* 2009; 69:836–844. [PubMed: 19176381]
5. Mahnke YD, Schwendemann J, Beckhove P, Schirrmacher V. Maintenance of long-term tumour-specific T-cell memory by residual dormant tumour cells. *Immunology.* 2005; 115:325–336. [PubMed: 15946250]
6. Klein CA. The direct molecular analysis of metastatic precursor cells in breast cancer: a chance for a better understanding of metastasis and for personalised medicine. *Eur J Cancer.* 2008; 44(18):2721–2725. [PubMed: 19022661]
7. Pantel K, Brakenhoff RH. Dissecting the metastatic cascade. *Nat Rev Cancer.* 2004; 4:448–456. [PubMed: 15170447]
8. Stoecklein NH, Hosch SB, Bezler M, Stern F, Hartmann CH, Vay C, et al. Direct genetic analysis of single disseminated cancer cells for prediction of outcome and therapy selection in esophageal cancer. *Cancer Cell.* 2008; 13:441–453. [PubMed: 18455127]
9. Husemann Y, Geigl JB, Schubert F, Musiani P, Meyer M, Burghart E, et al. Systemic spread is an early step in breast cancer. *Cancer Cell.* 2008; 13:58–68. [PubMed: 18167340]
10. Schardt JA, Meyer M, Hartmann CH, Schubert F, Schmidt-Kittler O, Fuhrmann C, et al. Genomic analysis of single cytokeratin-positive cells from bone marrow reveals early mutational events in breast cancer. *Cancer Cell.* 2005; 8:227–239. [PubMed: 16169467]
11. Schmidt-Kittler O, Ragg T, Daskalakis A, Granzow M, Ahr A, Blankenstein TJ, et al. From latent disseminated cells to overt metastasis: genetic analysis of systemic breast cancer progression. *Proc Natl Acad Sci USA.* 2003; 100:7737–7742. [PubMed: 12808139]
12. Klein CA. Parallel progression of primary tumours and metastases. *Nat Rev Cancer.* 2009; 9:302–312. [PubMed: 19308069]
13. Ossowski L, Aguirre-Ghiso JA. Dormancy of metastatic melanoma. *Pigment Cell Melanoma Res.* 2010; 23:41–56. [PubMed: 19843243]
14. Eyles J, Puaux AL, Wang X, Toh B, Prakash C, Hong M, et al. Tumor cells disseminate early, but immunosurveillance limits metastatic outgrowth, in a mouse model of melanoma. *J Clin Invest.* 2010; 120:2030–2039. [PubMed: 20501944]
15. Vidal M, Larson DE, Cagan RL. Csk-deficient boundary cells are eliminated from normal *Drosophila* epithelia by exclusion, migration, and apoptosis. *Dev Cell.* 2006; 10:33–44. [PubMed: 16399076]
16. Klein CA, Hölzel D. Systemic cancer progression and tumor dormancy: mathematical models meet single cell genomics. *Cell Cycle.* 2006; 5(16):1788–1798. [PubMed: 16929175]
17. Bidard FC, Vincent-Salomon A, Sigal-Zafrani B, Rodrigues M, Dieras V, Mignot L, et al. Time to metastatic relapse and breast cancer cells dissemination in bone marrow at metastatic relapse. *Clin Exp Metastasis.* 2008; 25:871–875. [PubMed: 18989740]
18. Schewe DM, Aguirre-Ghiso JA. Inhibition of eIF2alpha dephosphorylation maximizes bortezomib efficiency and eliminates quiescent multiple myeloma cells surviving proteasome inhibitor therapy. *Cancer Res.* 2009; 69:1545–1552. [PubMed: 19190324]
19. Kitzis A, Brizard F, Dascalescu C, Chomel JC, Guilhot F, Brizard A. Persistence of transcriptionally silent BCR-ABL rearrangements in chronic myeloid leukemia patients in sustained complete cytogenetic remission. *Leuk Lymphoma.* 2001; 42:933–944. [PubMed: 11697648]
20. Talpaz M, Estrov Z, Kantarjian H, Ku S, Foteh A, Kurzroc R. Persistence of dormant leukemic progenitors during interferon-induced remission in chronic myelogenous leukemia. Analysis by polymerase chain reaction of individual colonies. *J Clin Invest.* 1994; 94:1383–1389. [PubMed: 7929813]
21. Essers MA, Offner S, Blanco-Bose WE, Waibler Z, Kalinke U, Duchosal MA, et al. IFNalpha activates dormant haematopoietic stem cells in vivo. *Nature.* 2009; 458:904–908. [PubMed: 19212321]
22. Joyce JA, Pollard JW. Microenvironmental regulation of metastasis. *Nat Rev Cancer.* 2009; 9:239–252. [PubMed: 19279573]

23. Nguyen DX, Bos PD, Massague J. Metastasis: from dissemination to organ-specific colonization. *Nat Rev Cancer*. 2009; 9:274–284. [PubMed: 19308067]
24. Hickson JA, Huo D, Vander Griend DJ, Lin A, Rinker-Schaeffer CW, Yamada SD. The p38 kinases MKK4 and MKK6 suppress metastatic colonization in human ovarian carcinoma. *Cancer Res*. 2006; 66:2264–2270. [PubMed: 16489030]
25. Taylor J, Hickson J, Lotan T, Yamada DS, Rinker-Schaeffer C. Using metastasis suppressor proteins to dissect interactions among cancer cells and their microenvironment. *Cancer Metastasis Rev*. 2008; 27:67–73. [PubMed: 18049862]
26. Adam AP, George A, Schewe D, Bragado P, Iglesias BV, Ranganathan AC, et al. Computational identification of a p38SAPK-regulated transcription factor network required for tumor cell quiescence. *Cancer Res*. 2009; 69:5664–5672. [PubMed: 19584293]
27. Adorno M, Cordenonsi M, Montagner M, Dupont S, Wong C, Hann B, et al. A mutant-p53/Smad complex opposes p63 to empower TGFbeta-induced metastasis. *Cell*. 2009; 137:87–98. [PubMed: 19345189]
28. Aguirre Ghiso JA, Kovalski K, Ossowski L. Tumor dormancy induced by downregulation of urokinase receptor in human carcinoma involves integrin and MAPK signaling. *J Cell Biol*. 1999; 147:89–104. [PubMed: 10508858]
29. Barkan D, El Touny LH, Michalowski AM, Smith JA, Chu I, Davis AS, et al. Metastatic growth from dormant cells induced by a col-I-enriched fibrotic environment. *Cancer Res*. 2010; 70:5706–5716. [PubMed: 20570886]
30. Ranganathan AC, Ojha S, Kourtidis A, Conklin DS, Aguirre-Ghiso JA. Dual function of pancreatic endoplasmic reticulum kinase in tumor cell growth arrest and survival. *Cancer Res*. 2008; 68:3260–3268. [PubMed: 18451152]
31. Ranganathan AC, Zhang L, Adam AP, Aguirre-Ghiso JA. Functional coupling of p38-induced up-regulation of BiP and activation of RNA-dependent protein kinase-like endoplasmic reticulum kinase to drug resistance of dormant carcinoma cells. *Cancer Res*. 2006; 66:1702–1711. [PubMed: 16452230]
32. Ranganathan AC, Adam AP, Aguirre-Ghiso JA. Opposing roles of mitogenic and stress signaling pathways in the induction of cancer dormancy. *Cell Cycle*. 2006; 5(16):1799–1807. [PubMed: 16929185]
33. Harrison, LB.; Sessions, RB.; Ki-Hong, W. A multidisciplinary approach. 3. Lippincott Williams & Wilkins; Philadelphia: 2003. Head and neck cancer.
34. Gath HJ, Brakenhoff RH. Minimal residual disease in head and neck cancer. *Cancer Metastasis Rev*. 1999; 18:109–126. [PubMed: 10505550]
35. Wikman H, Vessella R, Pantel K. Cancer micrometastasis and tumour dormancy. *APMIS*. 2008; 116:754–770. [PubMed: 18834417]
36. Fan X, Valdimarsdottir G, Larsson J, Brun A, Magnusson M, Jacobsen SE, et al. Transient disruption of autocrine TGF-beta signaling leads to enhanced survival and proliferation potential in single primitive human hemopoietic progenitor cells. *J Immunol*. 2002; 168:755–762. [PubMed: 11777969]
37. Fortunel N, Hatzfeld J, Kisselev S, Monier MN, Ducos K, Cardoso A, et al. Release from quiescence of primitive human hematopoietic stem/progenitor cells by blocking their cell-surface TGF-beta type II receptor in a short-term in vitro assay. *Stem Cells*. 2000; 18:102–111. [PubMed: 10742382]
38. Scandura JM, Bocconi P, Massague J, Nimer SD. Transforming growth factor beta-induced cell cycle arrest of human hematopoietic cells requires p57KIP2 up-regulation. *Proc Natl Acad Sci USA*. 2004; 101:15231–15236. [PubMed: 15477587]
39. Yamazaki S, Iwama A, Takayanagi S, Eto K, Ema H, Nakauchi H. TGF-beta as a candidate bone marrow niche signal to induce hematopoietic stem cell hibernation. *Blood*. 2009; 113:1250–1256. [PubMed: 18945958]
40. Muraoka-Cook RS, Kurokawa H, Koh Y, Forbes JT, Roebuck LR, Barcellos-Hoff MH, et al. Conditional overexpression of active transforming growth factor beta1 in vivo accelerates metastases of transgenic mammary tumors. *Cancer Res*. 2004; 64:9002–9011. [PubMed: 15604265]

41. Kang Y, Siegel PM, Shu W, Drobnjak M, Kakonen SM, Cordon-Cardo C, et al. A multigenic program mediating breast cancer metastasis to bone. *Cancer Cell*. 2003; 3:537–549. [PubMed: 12842083]
42. Dumont N, Arteaga CL. Targeting the TGF beta signaling network in human neoplasia. *Cancer Cell*. 2003; 3:531–536. [PubMed: 12842082]
43. Siegel PM, Massague J. Cytostatic and apoptotic actions of TGF-beta in homeostasis and cancer. *Nat Rev Cancer*. 2003; 3:807–821. [PubMed: 14557817]
44. Hideshima T, Podar K, Chauhan D, Anderson KC. Cytokines and signal transduction. *Best Pract Res Clin Haematol*. 2005; 18:509–524. [PubMed: 16026734]
45. Javelaud D, Alexaki VI, Mauviel A. Transforming growth factor-beta in cutaneous melanoma. *Pigment Cell Melanoma Res*. 2008; 21:123–132. [PubMed: 18426405]
46. Hussein MR. Transforming growth factor-beta and malignant melanoma: molecular mechanisms. *J Cutan Pathol*. 2005; 32:389–395. [PubMed: 15953371]
47. Hsu MY, Rovinsky S, Penmatcha S, Herlyn M, Muirhead D. Bone morphogenetic proteins in melanoma: angel or devil? *Cancer Metastasis Rev*. 2005; 24:251–263. [PubMed: 15986135]
48. Reed JA, Bales E, Xu W, Okan NA, Bandyopadhyay D, Medrano EE. Cytoplasmic localization of the oncogenic protein Ski in human cutaneous melanomas in vivo: functional implications for transforming growth factor beta signaling. *Cancer Res*. 2001; 61:8074–8078. [PubMed: 11719430]
49. Zapas JL, Coley HC, Beam SL, Brown SD, Jablonski KA, Elias EG. The risk of regional lymph node metastases in patients with melanoma less than 1.0 mm thick: recommendations for sentinel lymph node biopsy. *J Am Coll Surg*. 2003; 197:403–407. [PubMed: 12946795]
50. Gamel JW, George SL, Edwards MJ, Seigler HF. The long-term clinical course of patients with cutaneous melanoma. *Cancer*. 2002; 95:1286–1293. [PubMed: 12216097]
51. Eskelin S, Pyrhonen S, Summanen P, Hahka-Kemppinen M, Kivela T. Tumor doubling times in metastatic malignant melanoma of the uvea: tumor progression before and after treatment. *Ophthalmology*. 2000; 107:1443–1449. [PubMed: 10919885]
52. Aguirre-Ghiso JA, Ossowski L, Rosenbaum SK. Green fluorescent protein tagging of extracellular signal-regulated kinase and p38 pathways reveals novel dynamics of pathway activation during primary and metastatic growth. *Cancer Res*. 2004; 64:7336–7345. [PubMed: 15492254]
53. Aguirre-Ghiso JA, Estrada Y, Liu D, Ossowski L. ERK(MAPK) activity as a determinant of tumor growth and dormancy; regulation by p38(SAPK). *Cancer Res*. 2003; 63:1684–1695. [PubMed: 12670923]
54. Aguirre-Ghiso JA, Liu D, Mignatti A, Kovalski K, Ossowski L. Urokinase receptor and fibronectin regulate the ERK(MAPK) to p38(MAPK) activity ratios that determine carcinoma cell proliferation or dormancy in vivo. *Mol Biol Cell*. 2001; 12:863–879. [PubMed: 11294892]
55. Liu D, Aguirre Ghiso J, Estrada Y, Ossowski L. EGFR is a transducer of the urokinase receptor initiated signal that is required for in vivo growth of a human carcinoma. *Cancer Cell*. 2002; 1:445–457. [PubMed: 12124174]
56. Aguirre Ghiso JA. Inhibition of FAK signaling activated by urokinase receptor induces dormancy in human carcinoma cells in vivo. *Oncogene*. 2002; 21:2513–2524. [PubMed: 11971186]
57. Schewe DM, Aguirre-Ghiso JA. ATF6alpha-Rheb-mTOR signaling promotes survival of dormant tumor cells in vivo. *Proc Natl Acad Sci USA*. 2008; 105:10519–10524. [PubMed: 18650380]
58. Ranganathan AC, Adam AP, Zhang L, Aguirre-Ghiso JA. Tumor cell dormancy induced by p38(SAPK) and ER-stress signaling: an adaptive advantage for metastatic cells? *Cancer Biol Ther*. 2006; 5:729–735. [PubMed: 16861922]
59. Fu Y, Li J, Lee AS. GRP78/BiP inhibits endoplasmic reticulum BIK and protects human breast cancer cells against estrogen starvation-induced apoptosis. *Cancer Res*. 2007; 67:3734–3740. [PubMed: 17440086]
60. Fukuyama M, Rougvie AE, Rothman JH. C. elegans DAF-18/PTEN mediates nutrient-dependent arrest of cell cycle and growth in the germline. *Curr Biol*. 2006; 16:773–779. [PubMed: 16631584]
61. Wang J, Kim SK. Global analysis of dauer gene expression in *Caenorhabditis elegans*. *Development*. 2003; 130:1621–1634. [PubMed: 12620986]

62. Long X, Spycher C, Han ZS, Rose AM, Muller F, Avruch J. TOR deficiency in *C. elegans* causes developmental arrest and intestinal atrophy by inhibition of mRNA translation. *Curr Biol*. 2002; 12:1448–1461. [PubMed: 12225660]
63. Lopez-Maury L, Marguerat S, Bahler J. Tuning gene expression to changing environments: from rapid responses to evolutionary adaptation. *Nat Rev Genet*. 2008; 9:583–593. [PubMed: 18591982]
64. Mizushima N, Levine B, Cuervo AM, Klionsky DJ. Autophagy fights disease through cellular self-digestion. *Nature*. 2008; 451:1069–1075. [PubMed: 18305538]
65. Klionsky DJ, Cregg JM, Dunn WA Jr, Emr SD, Sakai Y, Sandoval IV, et al. A unified nomenclature for yeast autophagy-related genes. *Dev Cell*. 2003; 5:539–545. [PubMed: 14536056]
66. Lum JJ, Bauer DE, Kong M, Harris MH, Li C, Lindsten T, et al. Growth factor regulation of autophagy and cell survival in the absence of apoptosis. *Cell*. 2005; 120:237–248. [PubMed: 15680329]
67. Roy S, Debnath J. Autophagy and tumorigenesis. *Semin Immunopathol*. 2010; 32:383–396. [PubMed: 20589500]
68. Komatsu M, Waguri S, Ueno T, Iwata J, Murata S, Tanida I, et al. Impairment of starvation-induced and constitutive autophagy in Atg7-deficient mice. *J Cell Biol*. 2005; 169:425–434. [PubMed: 15866887]
69. Kuma A, Hatano M, Matsui M, Yamamoto A, Nakaya H, Yoshimori T, et al. The role of autophagy during the early neonatal starvation period. *Nature*. 2004; 432:1032–1036. [PubMed: 15525940]
70. Melendez A, Talloczy Z, Seaman M, Eskelinen E-L, Hall DH, Levine B. Autophagy genes are essential for dauer development and life-span extension in *C. elegans*. *Science*. 2003; 301:1387–1391. [PubMed: 12958363]
71. Korah R, Boots M, Wieder R. Integrin alpha5beta1 promotes survival of growth-arrested breast cancer cells: an in vitro paradigm for breast cancer dormancy in bone marrow. *Cancer Res*. 2004; 64:4514–4522. [PubMed: 15231661]
72. White DE, Kurpios NA, Zuo D, Hassell JA, Blaess S, Mueller U, et al. Targeted disruption of beta1-integrin in a transgenic mouse model of human breast cancer reveals an essential role in mammary tumor induction. *Cancer Cell*. 2004; 6:159–170. [PubMed: 15324699]
73. Fung C, Lock R, Gao S, Salas E, Debnath J. Induction of autophagy during extracellular matrix detachment promotes cell survival. *Mol Biol Cell*. 2008; 19:797–806. [PubMed: 18094039]
74. Zhang XH, Wang Q, Gerald W, Hudis CA, Norton L, Smid M, et al. Latent bone metastasis in breast cancer tied to Src-dependent survival signals. *Cancer Cell*. 2009; 16:67–78. [PubMed: 19573813]
75. Han J, Hou W, Goldstein LA, Lu C, Stolz DB, Yin XM, et al. Involvement of protective autophagy in TRAIL resistance of apoptosis-defective tumor cells. *J Biol Chem*. 2008; 283:19665–19677. [PubMed: 18375389]
76. Herrero-Martin G, Hoyer-Hansen M, Garcia-Garcia C, Fumarola C, Farkas T, Lopez-Rivas A, et al. TAK1 activates AMPK-dependent cytoprotective autophagy in TRAIL-treated epithelial cells. *EMBO J*. 2009; 28:677–685. [PubMed: 19197243]
77. Lu Z, Luo RZ, Lu Y, Zhang X, Yu Q, Khare S, et al. The tumor suppressor gene ARHI regulates autophagy and tumor dormancy in human ovarian cancer cells. *J Clin Invest*. 2008; 118:3917–3929. [PubMed: 19033662]
78. Gupta A, Roy S, Lazar AJ, Wang WL, McAuliffe JC, Reynoso D, et al. Autophagy inhibition and antimalarials promote cell death in gastrointestinal stromal tumor (GIST). *Proc Natl Acad Sci USA*. 2010; 107:14333–14338. [PubMed: 20660757]
79. Rubin BP, Debnath J. Therapeutic implications of autophagy-mediated cell survival in gastrointestinal stromal tumor after treatment with imatinib mesylate. *Autophagy*. 2010; 6:1190–1191. [PubMed: 20930540]
80. Liang J, Shao SH, Xu ZX, Hennessy B, Ding Z, Larrea M, et al. The energy sensing LKB1-AMPK pathway regulates p27(kip1) phosphorylation mediating the decision to enter autophagy or apoptosis. *Nat Cell Biol*. 2007; 9:218–224. [PubMed: 17237771]

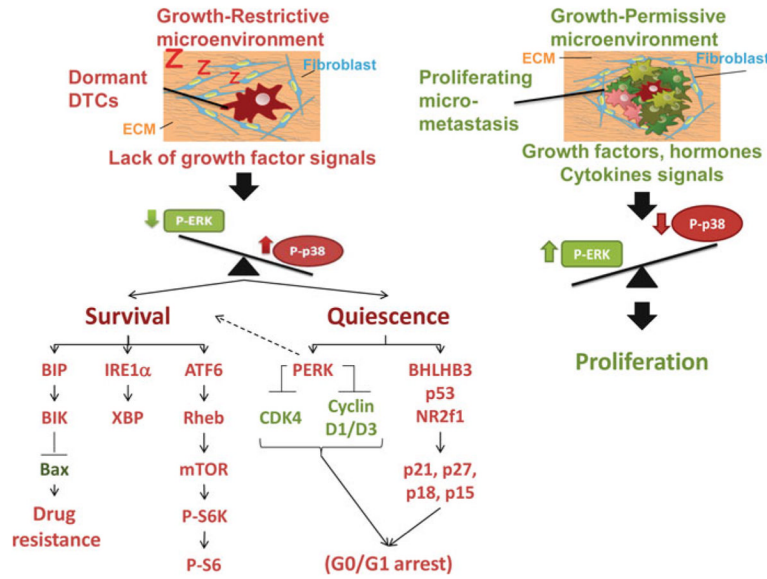

Fig. 5.1. Upon arrival at secondary sites, the crosstalk between the DTCs and the new microenvironment will determine the fate of the DTCs: In a permissive microenvironment (*right*), such as the lungs, interactions with the extracellular matrix (ECM), and stromal cells of the favorable microenvironment will allow DTCs to adapt and integrate growth-promoting signals, such as those derived from fibronectin, which will result in activation of mitogenic signaling (high ERK/low p38 ratio), thereby promoting DTC proliferation and the formation of micrometastasis. On the contrary, in restrictive microenvironments (*left*) such as bone marrow or liver for some cancers, either the loss of surface receptors or the interaction with non-growth-permissive ligands will result in activation of stress signaling (low ERK/high p38 ratio) that will induce both quiescence and survival signals, which will in turn lead to a prolonged phase of dormancy. Activation of p38 induces a G₀–G₁ arrest that is partly mediated by transcriptional activation of BHLHB3, NR2F1, and p53, which control the expression of different regulators of the cell cycle, such as p21, p27, p15, and p18, which mediate tumor cell growth arrest. Furthermore, active p38α induces an ER-stress response that coordinates growth arrest and survival through the activation of PERK, IRE-1, and ATF6. PERK contributes to both quiescence and survival of DTCs. Upon activation, PERK induces phosphorylation of EIF2α and attenuation of translation initiation, which leads to downregulation of cyclin D1/D3 and CDK4 and to the induction of quiescence. On the other hand, the other arms of the ER-stress pathways, ATF6α and IRE1α, contribute to DTC dormancy by promoting survival. IRE1α activation leads to the induction of XBP and the activation of the transcription of survival genes, whereas activation of ATF6α induces survival through the upregulation of Rheb and activation of mTOR signaling, allowing DTCs to adapt to the in vivo microenvironment. In addition to this, as part of the ER-stress response, the chaperone BiP/Grp78 is also activated, and this leads to inhibition of Bax activation to prevent apoptosis and thus, promote survival and drug resistance

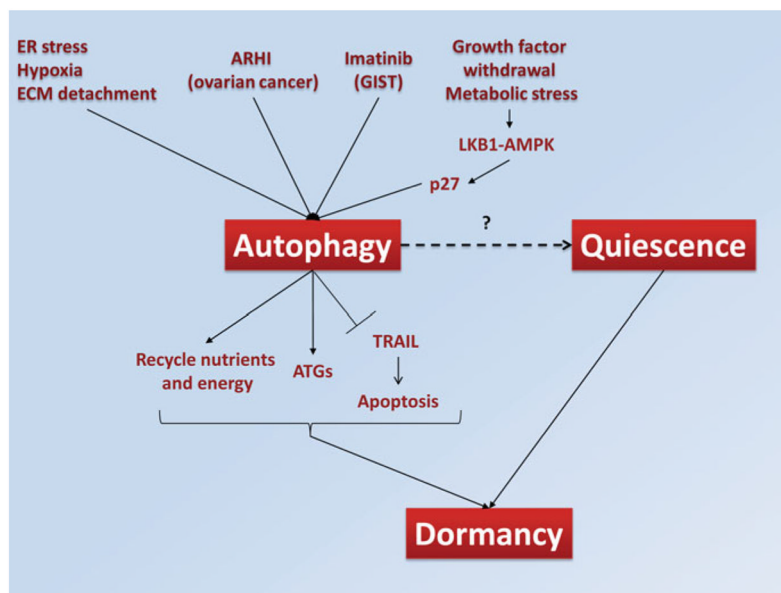

Fig. 5.2.

Activation of autophagy in response to different forms of stress can promote survival during growth arrest, making autophagy a component of dormant tumor cell survival. Autophagy is a stress-response mechanism that can be activated in response to various microenvironmental stresses such as hypoxia, extracellular matrix (ECM) detachment, endoplasmic reticulum (ER) stress, growth factor withdrawal, metabolic stress, activation of tumor suppressor genes (aplasia Ras homolog member I [*ARHI*]), or therapy-induced stress (Gleevec). Once activated, autophagy can mediate cell survival through different mechanisms that usually involve the activation of *ATG* genes, although it can also inhibit TRAIL-mediated apoptosis, for example. Some evidence exists that autophagy might contribute to tumor dormancy through the induction of tumor cell survival; for example, in ovarian carcinoma, *ARHI*-induced autophagy was shown to contribute to cell survival and tumor dormancy through restoration of PI3K signaling. Furthermore, in gastrointestinal stromal tumors (GIST), autophagy is induced in response to Gleevec, which leads to the induction of a dormant state in which these tumor cells can survive for extremely prolonged periods. Because autophagy can protect cells from different microenvironmental induced stresses, one can speculate that autophagy might be one of the mechanisms activated to promote the survival of dormant disseminated tumor cells in restrictive microenvironments

I κ B kinase complex (IKK) triggers detachment-induced autophagy in mammary epithelial cells independently of the PI3K-AKT-MTORC1 pathway

Nan Chen and Jayanta Debnath*

Department of Pathology and Helen Diller Family Comprehensive Cancer Center; University of California, San Francisco; San Francisco, CA USA

Keywords: autophagy, anoikis, extracellular matrix, integrin, mammary epithelial cells

Abbreviations: AKT, protein kinase B; CHUK/IKK α , conserved helix-loop-helix ubiquitous kinase/inhibitor of nuclear factor kappa-B kinase subunit α ; ECM, extracellular matrix; GAP, GTPase activating protein; IKBKG, inhibitor of nuclear factor kappa-B kinase subunit gamma (IKK- γ); ITGA3-ITGB1, α 3 β 1 integrin; ITGA6-ITGB4, α 6 β 4 integrin; I κ B, Inhibitors of NF κ B; I κ B-SR, I κ B super-repressor; IKBKB/IKK β , inhibitor of kappa light polypeptide gene enhancer in B-cells, kinase β /inhibitor of nuclear factor kappa-B kinase subunit β ; LAMA5, laminin 5; MAP3K7/TAK1, mitogen-activated protein kinase kinase 7/transforming growth factor- β -activated kinase 1; MEC, mammary epithelial cells; MTORC1, mammalian target of rapamycin complex 1; NF κ B, nuclear factor kappa B; MEFs, mouse embryonic fibroblasts; PI3K, phosphoinositide 3-kinase; rBM, reconstituted basement membrane; 3D culture, three-dimensional culture; RHEB, Ras homolog enriched in brain; RPS6, ribosomal protein S6; TSC1, tuberous sclerosis complex 1 (hamartin); TSC2, tuberous sclerosis complex 2 (tuberin)

Adherent cells require proper integrin-mediated extracellular matrix (ECM) engagement for growth and survival; normal cells deprived of proper ECM contact undergo anoikis. At the same time, autophagy is induced as a survival pathway in both fibroblasts and epithelial cells upon ECM detachment. Here, we further define the intracellular signals that mediate detachment-induced autophagy and uncover an important role for the I κ B kinase (IKK) complex in the induction of autophagy in mammary epithelial cells (MECs) deprived of ECM contact. Whereas the PI3K-AKT-MTORC1 pathway activation potentially inhibits autophagy in ECM-detached fibroblasts, enforced activation of this pathway is not sufficient to suppress detachment-induced autophagy in MECs. Instead, inhibition of IKK, as well as its upstream regulator, MAP3K7/TAK1, significantly attenuates detachment-induced autophagy in MECs. Furthermore, function-blocking experiments corroborate that both IKK activation and autophagy induction result from decreased ITGA3-ITGB1 (α 3 β 1 integrin) function. Finally, we demonstrate that pharmacological IKK inhibition enhances anoikis and accelerates luminal apoptosis during acinar morphogenesis in three-dimensional culture. Based on these results, we propose that the IKK complex functions as a key mediator of detachment-induced autophagy and anoikis resistance in epithelial cells.

Introduction

Extracellular matrix (ECM) interactions with integrin receptors play a critical role in cell proliferation, growth and survival. The detachment of cells from ECM disrupts integrin engagement and triggers programmed cell death, termed anoikis.^{1,2} Anoikis prevents normal epithelial cells from colonizing in inappropriate ECM environments, thus maintaining tissue integrity. Studies of lumen formation in three-dimensional culture of mammary epithelial cells (MEC) reveal a critical role for anoikis in luminal clearance.³ On the other hand, evidence also indicates that ECM detachment can trigger antiapoptotic signals, which presumably allow cells to survive for limited periods of time prior

to reestablishing ECM contact.¹ Recent work demonstrates that the induction of autophagy, an evolutionally conserved lysosomal degradation process, serves as important survival pathway during ECM detachment. Inhibiting autophagy enhances anoikis and accelerates luminal clearance in 3D mammary epithelial cultures.⁴ Importantly, antibody-mediated blockade of ITGB1/integrin β 1 function is sufficient to induce autophagy in attached cells, while the addition of a laminin-rich ECM abrogates autophagy in detached cells; collectively, these findings indicate that the loss of ECM-integrin receptor engagement directly mediates detachment-induced autophagy.⁴

Currently, the intracellular signals linking the loss of ECM-integrin receptor engagement to detachment-induced autophagy

*Correspondence to: Jayanta Debnath; Email: Jayanta.Debnath@ucsf.edu
Submitted: 12/19/12; Revised: 04/25/13; Accepted: 04/29/13
<http://dx.doi.org/10.4161/auto.24870>

remain poorly defined. In mammalian cells, multiple pathways regulate autophagy during starvation or stress; among these, the PI3K-AKT-MTORC1 pathway is the archetypal regulator of autophagy.⁵ MTORC1 activity is inversely correlated with autophagy induction. Both nutrient starvation and growth factor withdrawal cause deactivation of the PI3K-AKT-MTORC1 pathway, resulting in the induction of autophagy. Furthermore, during ECM detachment, recent work suggests that activation of the endoplasmic reticulum (ER) kinase, EIF2AK3/PERK can promote autophagy via inhibition of the MTORC1 pathway.⁶

In addition to MTORC1, the nuclear factor kappa B (NFkB) signaling pathway has been implicated in both autophagy regulation as well as anoikis resistance.^{7,8} The NFkB pathway is involved in the transcriptional control of multiple cellular functions, including cell proliferation, apoptosis, differentiation, inflammation and immune response. The IκB kinase (IKK) complex, the major regulator of the NFkB pathway, consists of two highly related catalytic subunits (CHUK/IKKα and IKBKB/IKKβ) and a regulatory subunit (IKBKγ/IKKγ). In unstimulated cells, the NFkB proteins assemble inactive complexes with Inhibitors of NFkB/κB (IκB) proteins in the cytoplasm. Upon upstream kinases stimulation, IKK kinases phosphorylate the inhibitory molecule IκB, resulting in ubiquitination and degradation of IκB via proteasomes. Subsequently, the free NFkB dimers translocate to the nucleus and bind to κB sites on target genes, many of which are involved in stimulating inflammation, preventing apoptosis and enhancing cell proliferation.⁹

Notably, IKK can directly phosphorylate cellular proteins distinct from NFkB and IκB proteins, indicating that this kinase complex has biological functions beyond its canonical role in the NFkB pathway.¹⁰ Remarkably, recent work has revealed a new link between IKK complex activation and autophagy induction via an NFkB independent mechanism; diverse autophagic stimuli activate the IKK complex and that IKK is required for optimal autophagy induction both *in vitro* and *in vivo*.⁸ Importantly, IKK activation mediated autophagy induction can be uncoupled from NFkB activation. Consistent with these findings, both CHUK and IKBKB are required for starvation-induced autophagy; furthermore, IKK, but not NFkB, was critical for basal and starvation-induced autophagy gene expression.¹¹ Altogether, these findings suggest that autophagy can be regulated in an IKK-dependent, NFkB-independent manner in mammalian cells. Interestingly, IKBKB activity can also be downregulated by autophagic degradation, suggesting a complex interplay between autophagy and the IKK-NFkB pathway.^{12,13}

In this study, we sought to delineate the intracellular signals necessary to induce autophagy in cells deprived of ECM contact. Whereas the PI3K-AKT-MTORC1 pathway is a major regulator of autophagy induction in detached mouse fibroblasts, the activation of IKK complex plays a key role in promoting autophagy in MECs deprived of ECM contact. We also demonstrated that the blockade of ITGA3-ITGB1 (α3β1 integrin) function is sufficient to activate IKK as well as induce autophagy in MECs. Moreover, pharmacological IKK inhibition enhances anoikis and accelerates luminal apoptosis during acinar morphogenesis

in three-dimensional culture. Hence, we propose that the IKK complex functions as a key regulator of detachment-induced autophagy and anoikis resistance in specific cell types.

Results

Activation of the PI3K-AKT-MTORC1 pathway suppresses detachment-induced autophagy in mouse fibroblasts. A large body of work demonstrates that inactivation of MTORC1 plays an essential role in autophagy induction in response to diverse stimuli, including nutrient deprivation and loss of growth factor signals.⁵ To assess if MTORC1 activity is reduced during ECM detachment, we cultured mouse embryonic fibroblasts (MEFs) and mammary epithelial cells (MCF10A) on poly-HEMA coated tissue culture dishes to prevent adhesion and monitored MTORC1 activity via the phosphorylation status of its well-defined downstream targets RPS6KB1 or RPS6.¹⁴ In both cell types, we observed decreased MTORC1 activity in detached cells, which correlated with an increase in autophagic flux, evidenced by the increased turnover of the cleaved and phosphatidylethanolamine conjugated-form of LC3 (LC3-II) in the presence of the lysosomal cathepsin inhibitors E64d and pepstatin A (E/P) (Fig. S1).

As a result, we examined whether enforced MTORC1 activation during ECM detachment was sufficient to suppress autophagy. TSC1 and TSC2 form a complex to inactivate the RHEB GTPase, leading to inactivation of MTORC1. Cells lacking TSC2 exhibit deregulated hyperactivation of MTORC1.¹⁵ Hence, we utilized *tsc2*^{-/-} MEFs to test whether activation of MTORC1 suppresses autophagy induction during ECM detachment. *Tsc2*^{+/+} or *tsc2*^{-/-} MEFs were cultured attached or in suspension for 24 h to assay autophagic flux. Although increased LC3-II conversion and turnover was observed in suspended *Tsc2*^{+/+} MEFs, LC3-II conversion and turnover were potently inhibited in *tsc2*^{-/-} cells (Fig. 1A). To more rigorously validate these findings, we performed a rescue experiment and stably reintroduced either wild-type human TSC2 or a mutant version of TSC2^{N1643I} into *tsc2*^{-/-} MEFs. TSC2^{N1643I} contains a point mutation in its GTPase activating protein (GAP) domain that abolishes the GAP activity toward RHEB, thereby rendering it unable to modulate MTORC1 activity. As shown in Figure 1A, wild-type TSC2 but not TSC2^{N1643I} rescued autophagy induction during ECM detachment in *tsc2*^{-/-} MEFs. Importantly, the rescued autophagy induction also correlates with the ability of TSC2 to downregulate MTORC1 activity as monitored by RPS6 phosphorylation (Fig. 1B). These results support the idea that loss of MTORC1 activity functionally contributes to ECM detachment-induced autophagy in fibroblasts.

In response to growth factors, AKT directly phosphorylates multiple sites on TSC2 that suppress the inhibitory effect of TSC2 toward RHEB and MTORC1.^{16,17} During ECM detachment, we also observed decreased AKT activity in suspended cells (Fig. 1C). To investigate whether AKT and its upstream regulator PI3K contribute to autophagy regulation during ECM detachment, we stably expressed activated forms of PIK3CA* (PIK3CA^{E545K}) and AKT (myrAKT) in wild-type MEFs. Cells

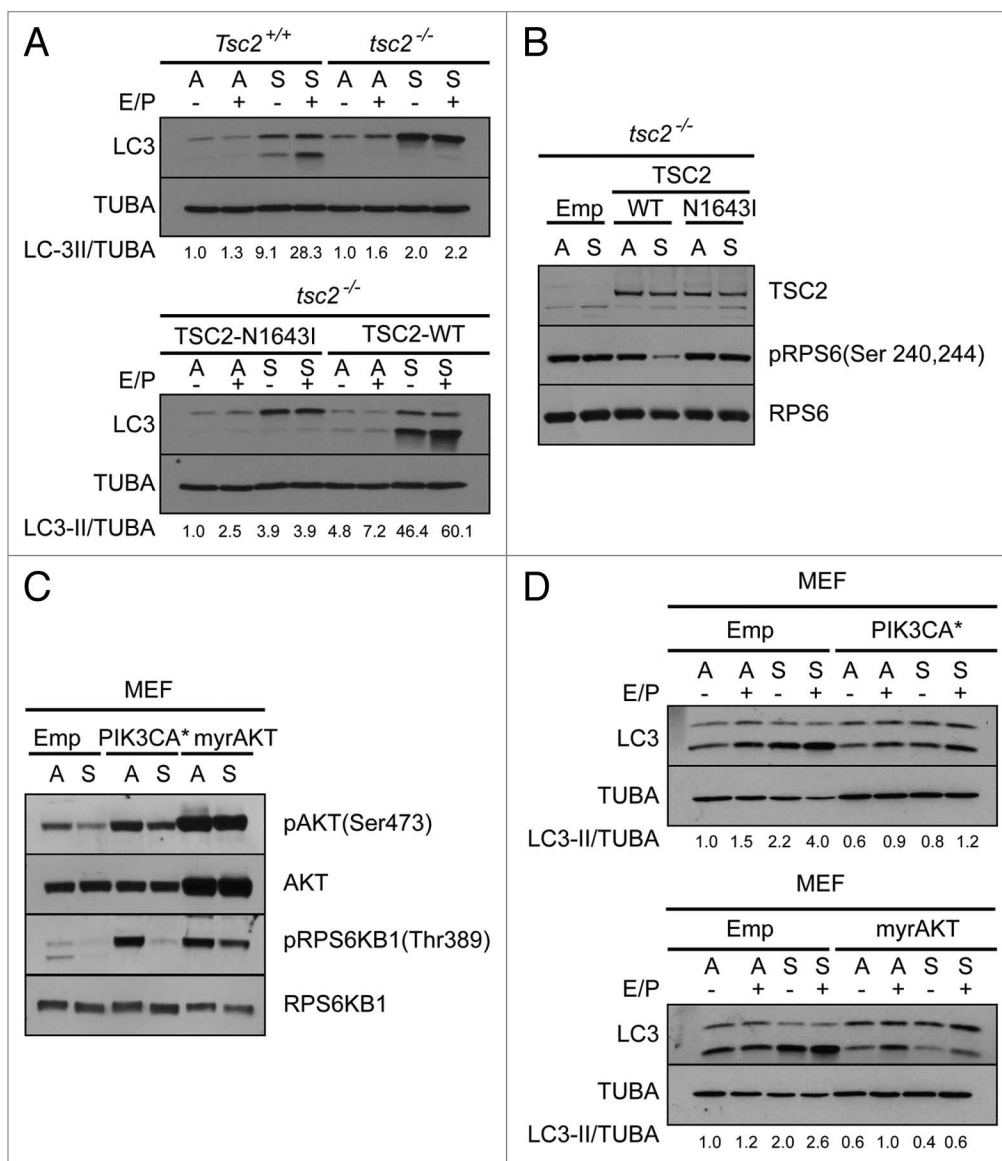

Figure 1. Activation of PI3K-AKT-MTORC1 pathway suppresses ECM detachment-induced autophagy in mouse embryonic fibroblasts (MEFs). **(A)** Top: Lysates from *Tsc2*^{+/+} or *tsc2*^{-/-} MEFs grown attached (A) or suspended (S) for 24 h were immunoblotted with anti-LC3 and anti-tubulin (TUBA) antibodies. Where indicated, E64d and pepstain A (E/P) were added 6 h prior to harvesting. Bottom: *tsc2*^{-/-} MEFs stably expressing TSC2^{N1643I} or wild-type TSC2 (TSC2-WT) were grown attached or suspended for 24 h were immunoblotted with anti-LC3 and anti-TUBA antibodies. Where indicated, E64d and pepstain A (E/P) were added 6 h prior to harvesting. **(B)** Lysates from *tsc2*^{-/-} MEFs stably expressing empty vector (Emp), TSC2-WT or TSC2^{N1643I} were grown attached (A) or in suspended (S) for 24 h were subject to immunoblotting with antibodies against TSC2, phospho-RPS6 ribosomal protein (Ser240,244) [pRPS6(Ser240,244)] and RPS6 ribosomal protein (RPS6). **(C)** Wild-type MEFs stably expressing empty vector (Emp), activated PIK3CA (PIK3CA*), or myristoylated AKT (myrAKT) were grown attached (A) or suspended (S) for 24 h. Cell lysates were subject to immunoblotting with antibodies against phospho-AKT(Ser473) [pAKT(Ser473)], AKT, phospho-p70 RPS6 Kinase(Thr389) [pRPS6KB1(Thr389)] or RPS6KB1. **(D)** Wild-type MEFs stably expressing empty vector (Emp) and PIK3CA* (top) or myrAKT (bottom) were grown attached (A) or suspended (S) for 24 h were immunoblotted with anti-LC3 and anti-TUBA antibodies. Where indicated, E64d and pepstain A (E/P) were added 6 h prior to harvesting.

expressing PIK3CA* and myrAKT exhibited higher levels of AKT and RPS6KB1 phosphorylation during both attachment and suspension, indicative of potentially sustained activation of the AKT-MTORC1 pathway. At the same time, upon matrix detachment, LC3 conversion and LC3-II turnover were significantly reduced in PIK3CA* and myrAKT cells compared with empty vector controls (Fig. 1D). Together, these data corroborate that in fibroblasts, reduced activation of the PI3K-AKT-MTORC1

pathway plays a key role in autophagy induction during ECM detachment.

PI3K-AKT-MTORC1 activation does not inhibit autophagy in detached mammary epithelial cells. Next, we examined whether autophagy was regulated similarly in mammary epithelial cells. MCF10A cells were transfected with siRNA oligonucleotide pools targeting endogenous TSC2 and thereafter, grown attached or in suspension for 24 h. We confirmed

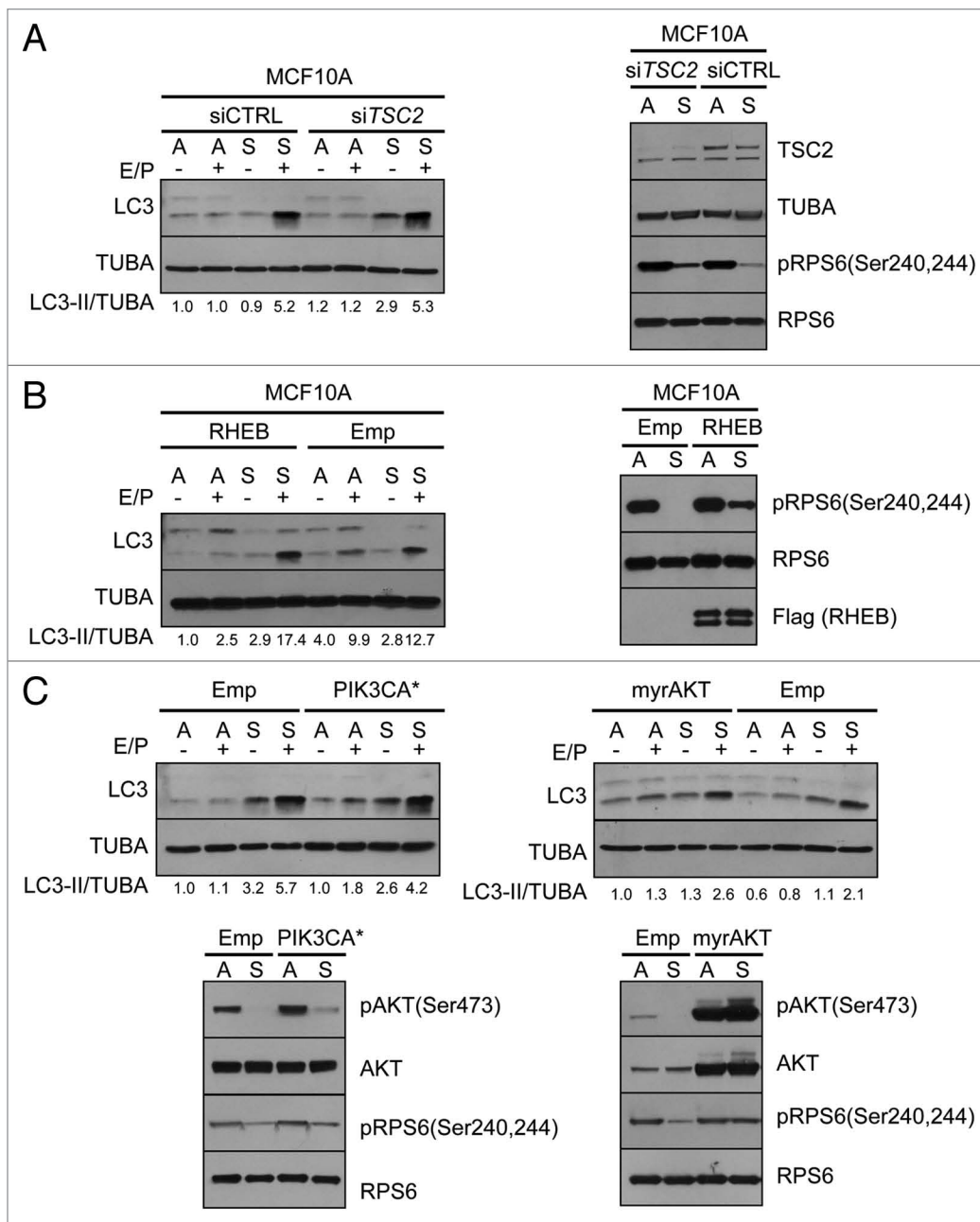

Figure 2. Activation of PI3K-AKT-MTORC1 pathway is not sufficient to suppress autophagy upon ECM detachment in mammary epithelial cells (MECs). (A) Left: MCF10A cells transfected with pooled nontargeting control (siCTRL) or siRNA against *TSC2* (siTSC2) were grown attached (A) or suspended (S) for 24 h were lysed and immunoblotted with anti-LC3 and anti-TUBA antibodies. Where indicated, E64d and pepstain A (E/P) were added 6 h prior to harvesting. Right: Lysates from MCF10A cells transfected with siCTRL or siTSC2 and then grown attached (A) or suspended (S) for 24 h were subject to immunoblotting with antibodies against TSC2, TUBA, pRPS6(Ser240,244) and RPS6. (B) Left: MCF10A cells stably expressing empty vector (Emp) or flag-tagged RHEB (RHEB) were grown attached (A) or suspended (S) for 24 h were lysed and immunoblotted with anti-LC3 and anti-TUBA antibodies. Where indicated, E64d and pepstain A (E/P) were added 6 h prior to harvesting. Right: Lysates from MCF10A cells stably expressing empty vector (Emp) or flag-tagged RHEB (RHEB) grown attached (A) or suspended (S) for 24 h were subject to immunoblotting with indicated antibodies. (C) Top: MCF10A cells stably expressing empty vector (Emp), PIK3CA* (left), or myrAKT (right) were grown attached (A) or suspended (S) for 24 h were lysed and immunoblotted with anti-LC3 and anti-TUBA antibodies. Where indicated, E64d and pepstain A (E/P) were added 6 h prior to harvesting. Bottom: MCF10A cells stably expressing empty vector (Emp), PIK3CA*, or myrAKT were grown attached or suspended for 24 h, lysed and immunoblotted with indicated antibodies.

efficient RNAi-mediated depletion of endogenous TSC2; moreover, TSC2 knockdown resulted in elevated RPS6 phosphorylation during detachment, in comparison to nontargeting control

(siCTRL) cells (Fig. 2A). Nevertheless, we observed high levels of LC3 conversion and autophagic flux in siTSC2 cells during substratum detachment (Fig. 2A). Because TSC2 depletion was

not sufficient to sustain RPS6 phosphorylation in detached cells to levels equivalent to attached controls, we construed that the residual levels of endogenous TSC2 in the RNAi-depleted cells were potentially sufficient to downregulate MTORC1 activity during detachment. Accordingly, we stably overexpressed RHEB to maintain MTORC1 activity.¹⁸ Compared with control cells, a stronger phosphorylated RPS6 signal was detected in RHEB overexpressing cells in suspension. However, no significant decrease of LC3 conversion or autophagic flux in RHEB overexpressing cells was observed compared with empty vector control (Emp) (Fig. 2B). Since RPS6 phosphorylation was once again not fully restored to levels observed in attached cells, we speculated that other TSC2-RHEB-independent pathways also regulate MTORC1 activity during ECM detachment in MECs. For example, AKT1S1/PRAS40, a component of MTORC1 has been reported to inhibit RHEB-induced activation of the MTORC1 pathway.¹⁹ On the other hand, AKT directly phosphorylates AKT1S1 and prevents its inhibition of MTORC1.²⁰ Hence, to scrutinize whether activation of the PI3K-AKT pathway was sufficient to maintain MTORC1 activity and suppress autophagy induction, we generated stable MCF10A cell lines expressing PIK3CA* or myrAKT. Nonetheless, upon ECM detachment, we did not detect any significant change on LC3 conversion or LC3-II flux in PIK3CA* or myrAKT cells compared with empty vector control (Emp) cells. Importantly, in myrAKT cells, detachment-induced autophagy was robustly induced, despite the fact that AKT and MTORC1 activation were fully sustained in detached cells to levels comparable to attached controls (Fig. 2C). Based on these results, we hypothesized that additional intracellular signals may trigger ECM detachment-induced autophagy in MECs independently of the PI3K-AKT-MTORC1 pathway.

IKK activation promotes autophagy induction upon substratum detachment in epithelial cells. Recently, the Kroemer group has reported that activation of the IKK complex contributes to induction of autophagy in response to diverse stimuli.⁸ We therefore investigated whether IKK is activated in response to ECM detachment in MECs. MCF10A cells were grown attached or in suspension for 24 h; thereafter, the endogenous IKK complex was immunoprecipitated from protein lysates and its activation status was evaluated by immunoblotting. As shown in Figure 3A, matrix detachment induced phosphorylation of the activation sites of IKK [CHUK(Ser176,180)/IKKBK(Ser177,181)]. Moreover, potent phosphorylation on the IKK substrate, NFKBIA/I κ B α was also detected in suspended, but not in attached cells. Together, these data support that the IKK complex is activated during ECM detachment in MCF10A cells. Notably, activation of the IKK complex was not observed in MEFs lacking ECM contact (Fig. S2), indicating that this signaling pathway was distinctly activated in MECs in response to ECM detachment.

Next, we investigated whether inhibition of IKK was sufficient to prevent autophagy induction during ECM detachment. MCF10A cells were cultured in attached or suspended conditions for 24 h in the presence or absence of the IKK kinase inhibitor Bay-117082.²¹ A significant reduction in autophagic flux was observed in suspended cells treated with Bay-117082 (Fig. 3B). In addition, in MCF-10A cells stably expressing GFP-LC3,

Bay-117082 potently suppressed GFP-LC3 puncta formation during ECM detachment (Fig. 3C). Furthermore, Bay-117082 treatment efficiently suppressed NFKBIA phosphorylation, but did not significantly alter the activation status of AKT or MTORC1 in suspended cells (Fig. 3D). We corroborated these results using loss-of-function approaches targeting various IKK complex components. First, we utilized MCF10A cells expressing dominant negative CHUK (DN-CHUK)²² or IKKBK (DN-IKKBK)²³ to inhibit IKK activation in detached cells. Compared with controls, the expression of DN-IKKBK suppressed LC3-II conversion and turnover in ECM detached cells (Fig. 4A), whereas DN-CHUK had minimal effects on autophagy induction. Consistent with this observation, DN-IKKBK, but not DN-CHUK, suppressed NFKBIA phosphorylation in suspended cells (Fig. 4B). Neither DN-CHUK nor DN-IKKBK significantly affected MTORC1 activity in suspended cells, as evidenced by RPS6 phosphorylation. Furthermore, RNAi-mediated depletion of the key regulatory component of the IKK complex, IKKBK, also potently inhibited LC3-II conversion and turnover during ECM detachment (Fig. 4C). Once again, upon IKKBK depletion, phosphorylation of NFKBIA was decreased in suspended cells, but no significant changes were observed in the phosphorylation status of AKT and RPS6 in IKKBK knockdown cells compared with controls.

Multiple signaling pathways regulate IKK complex activation²⁴ and one of these upstream regulators, MAP3K7/TAK1, has been linked to autophagy induction.⁸ Accordingly, RNAi-mediated depletion of MAP3K7 significantly suppressed NFKBIA phosphorylation during ECM detachment as well as attenuated detachment-induced autophagy, without impacting AKT or MTORC1 activity in suspended cells (Fig. 4D). Taken together, these data indicate that, in contrast to mouse fibroblasts, the MAP3K7-IKK axis plays a critical role in ECM detachment-induced autophagy in MECs.

Because recent work suggests that IKK complex activation promotes autophagy via an NFKB-independent mechanism, we further assessed whether NFKB activation was specifically required for detachment-induced autophagy. MCF10A cells were stably infected with a retroviral construct expressing I κ B super-repressor (I κ B-SR), a mutant form of NFKBIA^{S32A,S36A} that does not undergo signal-induced phosphorylation and degradation. Expression of I κ B-SR efficiently blocks NFKB nuclear translocation and prevents target gene transcription.²⁵ As shown in Figure S3, overexpression of I κ B-SR effectively blocked the phosphorylation of NFKBIA in response to ECM deprivation or TNF/TNF α treatment. However, no significant change on LC3-II conversion and turnover was observed between suspended cells expressing control vector or I κ B-SR. Overall, this data indicates that autophagy in ECM deprived mammary epithelial cells is induced in an IKK-dependent, NFKB-independent manner.

Antibody-mediated function blockade of ITGA3-ITGB1 induces IKK activation and autophagy in MECs. Integrins are the major receptors for cell adhesion to the ECM that transduce outside-in signals from the ECM.²⁶ Hence, we tested whether autophagy induction during ECM detachment directly results from the blockade of signals emanating from specific

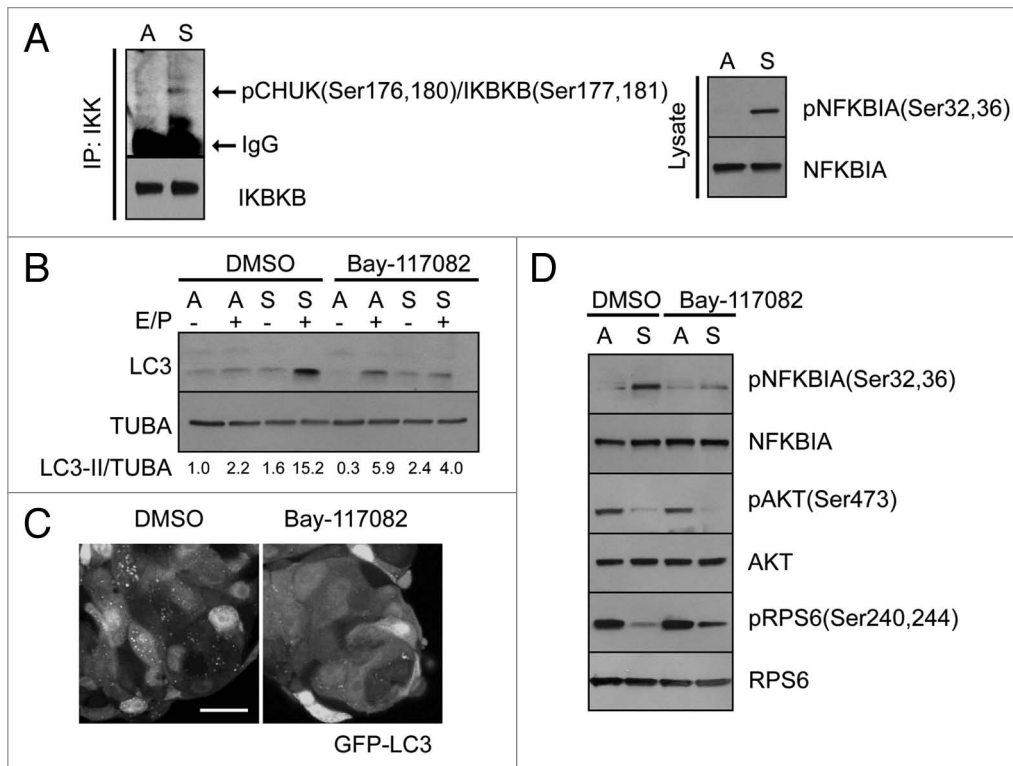

Figure 3. Inhibition of IKK activity suppresses autophagy induction in ECM deprived MECs. **(A)** Left: Lysates from MCF10A cells grown in attached (A) or suspended (S) for 24 h were subject to immunoprecipitation with antibodies against CHUK and IKKBK. Immunoprecipitates were subject to immunoblotting with antibodies against phospho-CHUK(Ser176,180)/IKKBK(Ser177,181). Right: Lysates from MCF10A cells grown in attached (A) or suspended (S) for 24 h were subject to immunoblotting with antibodies against phospho-NFKBIA(Ser32,36) [pIkBa(Ser32,36)] and NFKBIA (IkB α). **(B)** MCF10A cells treated with DMSO or 10 μ M Bay-117082 were grown attached (A) or suspended (S) for 24 h, lysed and immunoblotted with anti-LC3 and anti-TUBA antibodies. Where indicated, E64d and pepstain A (E/P) were added 6 h prior to harvesting. **(C)** MCF10A cells stably expressing GFP-LC3 were grown suspended for 24 h in the presence of DMSO (left) or 10 μ M Bay-117082 (right). Scale bar: 25 μ m. **(D)** MCF10A cells treated with DMSO or 10 μ M Bay-117082 were grown attached (A) or suspended (S) for 24 h, lysed and immunoblotted with the indicated antibodies.

integrin subunits. Extending our previous results,⁴ incubation of MCF10A cells with ITGB1 function-blocking antibody AIB2 caused severe cell detachment and rounding (Fig. 5A, left), as well as increased LC3-II conversion and turnover (Fig. 5A, right). Moreover, we also observed a significant elevation of NFKBIA phosphorylation in AIB2 treated cells (Fig. 5B), indicating that blockade of ITGB1 function resulted in activation of the IKK pathway. The integrin complexes ITGA3-ITGB1 and ITGA6-ITGB4 (α 6 β 4 integrin) are the major receptors for LAMA5 (laminin-5), an important component of the epithelial cell basement membrane.^{27,28} To further ascertain how each of these integrin receptor subunits contributes to IKK activation and autophagy induction during ECM detachment, we preincubated cells with function-blocking antibodies directed against each integrin subunit. As shown in Figure 5C, MCF10A cells stably expressing GFP-LC3 were preincubated with function-blocking antibodies against ITGA3 (P1B5),²⁹ ITGB1 (AIB2),³⁰ ITGA6 (G0H3),³¹ or ITGB4 (ASC-8)³² for 30 min and seeded onto tissue culture plates coated with laminin-rich reconstituted basement membrane (rBM). After 16 h, IgG treated control cells were fully adherent to culture plates. Cells incubated with function-blocking antibodies against the ITGA3, ITGA6 or ITGB4 integrin subunits were also attached and spread on

the plates, whereas anti-ITGB1 antibody-treated cells failed to spread on this substratum and remained only partially attached to the plate (Fig. 5C). ITGB1 function blockade induced potent GFP-LC3 puncta formation in MCF10A cells. Moreover, we also observed strong induction of GFP-LC3 puncta in response to the block in ITGA3 functions. In contrast, no increase in punctate GFP-LC3 was present in IgG-treated controls or in cells incubated with anti-ITGA6 or ITGB4 antibodies (Fig. 5C). Together, these results suggest that a block in the function of the ITGA3-ITGB1 complex is sufficient to induce autophagy. Moreover, the blockade of either ITGA3 or ITGB1 caused an increase in NFKBIA phosphorylation, while blockade of ITGA6 or ITGB4 had less pronounced effects (Fig. 5D). These results motivated the hypothesis that the specific loss in ITGA3-ITGB1 function stimulates autophagy via activation of the IKK pathway.

To further test this prediction, we evaluated whether IKK pathway inhibition is sufficient to prevent autophagosome (GFP-LC3 puncta) induction during ITGA3-ITGB1 blockade. Because anti-ITGB1 antibody treatment causes severe cell rounding, the rigorous quantification of GFP-LC3 was not technically possible; as a result, we employed anti-ITGA3 for these experiments. MCF10A cells stably expressing GFP-LC3 were

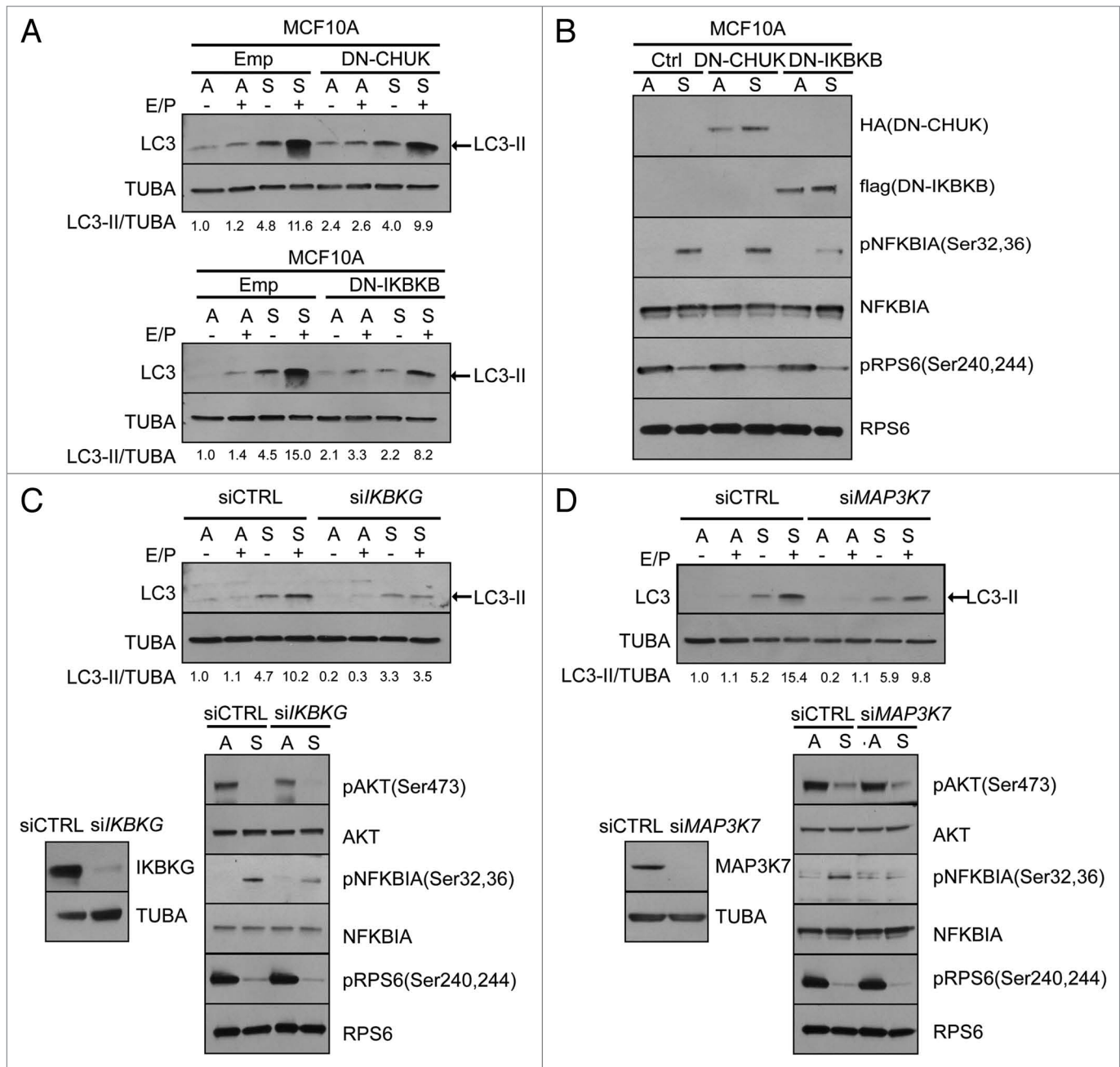

Figure 4. MAP3K7/IKK pathway promotes ECM detachment-induced autophagy in MECs. **(A)** MCF10A cells transiently transfected with empty vector (Emp), vector expressing dominant negative CHUK (DN-CHUK) (top), or dominant negative IKBKB (DN-IKBKB) (bottom) were grown attached (A) or suspended (S) for 24 h, lysed and immunoblotted with anti-LC3 and anti-TUBA antibodies. Where indicated, E64d and pepstain A (E/P) were added 6 h prior to harvesting. LC3-I detection was minimal in this experiment. **(B)** MCF10A cells transiently transfected with empty vector (Emp), vector expressing DN-CHUK or DN-IKBKB were grown attached (A) or suspended (S) for 24 h, lysed and immunoblotted with the indicated antibodies. **(C)** Top: MCF10A cells transfected with siCTRL or siIKBKG were grown attached or suspended for 24 h. Where indicated, E64d and pepstain A (E/P) were added 6 h prior to harvesting. Cell lysates were subject to immunoblotting with antibodies against LC3 and TUBA. LC3-I detection was minimal in this experiment. Bottom left: IKBKG protein levels in MCF10A cells transfected with siCTRL or siIKBKG. Bottom right: siCTRL or siIKBKG expressing MECs were grown attached or suspended for 24 h, lysed and immunoblotted with indicated antibodies. **(D)** Top: MCF10A cells transfected with siCTRL or siMAP3K7 were grown attached or suspended for 24 h. Where indicated, E64d and pepstain A (E/P) were added 6 h prior to harvesting. Cell lysates were subject to immunoblotting with antibodies against LC3 and TUBA. LC3-I detection was minimal in this experiment. Bottom left: MAP3K7 protein levels in MCF10A cells transfected with siCTRL or siMAP3K7. siCTRL or siMAP3K7-expressing MECs were grown attached or suspended for 24 h, lysed and immunoblotted with the indicated antibodies.

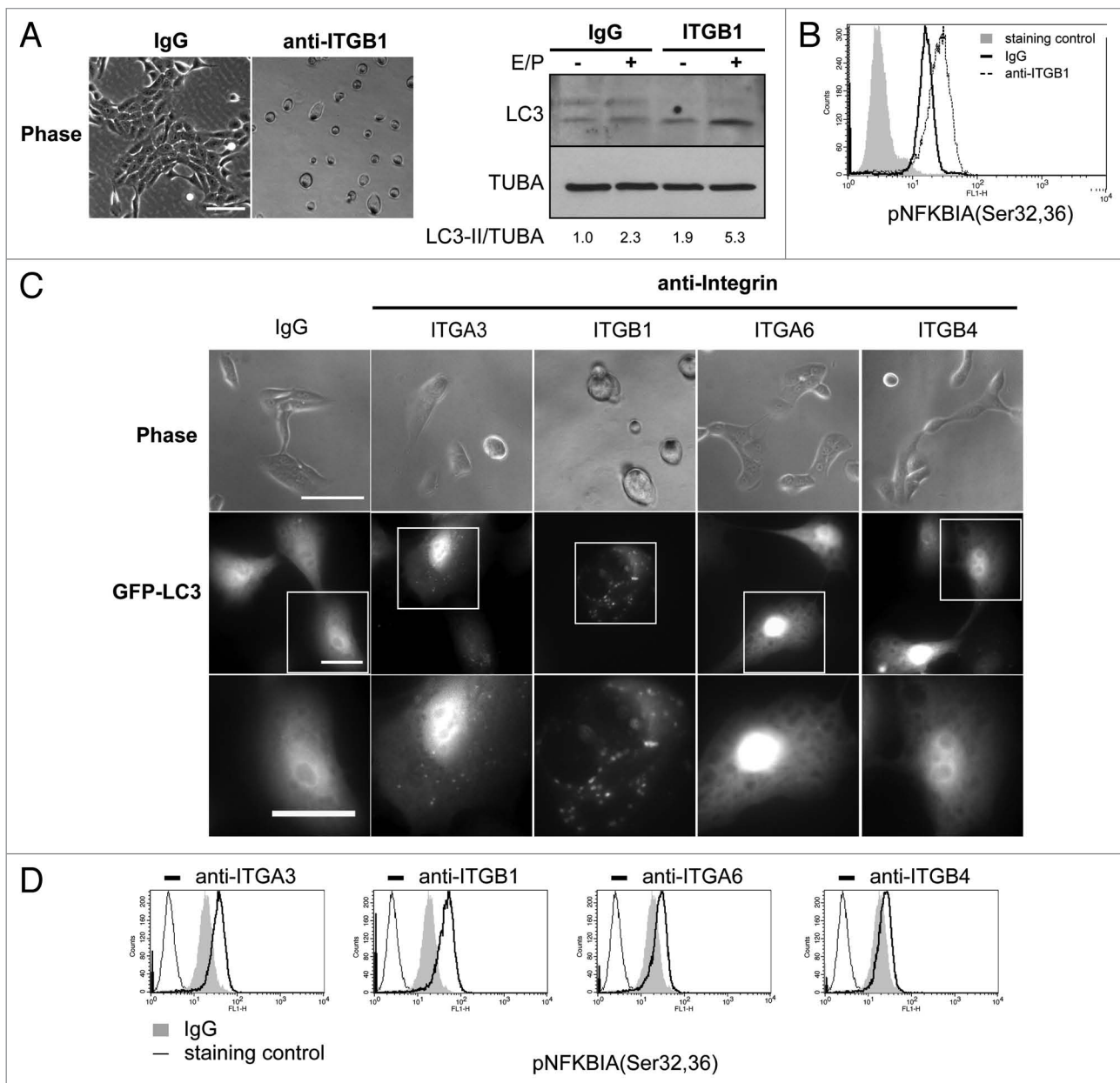

Figure 5. Antibody-mediated blockade of ITGA3-ITGB1 function induces IKK activation and autophagy in MECs. **(A)** Left: Phase images of MCF10A cells incubated with 20 μ g/ml IgG or anti-ITGB1 prior to seeding to rBM (Matrigel)-coated culture plates for 24 h. Scale bar: 100 μ m. Right: MCF10A cells preincubated with 20 μ g/ml IgG or anti-ITGB1 were cultured on rBM-coated culture plates for 24 h. Cell lysates were subject to immunoblotting against LC3 and TUBA. Where indicated, E64d and pepstain A (E/P) were added 6 h prior to harvesting. **(B)** MCF10A cells were preincubated with 20 μ g/ml IgG or anti-ITGB1 prior to seeding to rBM-coated culture plates for 24 h. pNFKBIA(Ser32,36) levels were detected by flow cytometry in permeabilized cells. **(C)** MCF10A cells expressing GFP-LC3 were incubated with the indicated antibodies at 20 μ g/ml before seeding to rBM-coated culture plates for 16 h. Top: Phase images. Scale bar: 100 μ m. Middle: Fluorescent images of GFP-LC3. Scale bar: 20 μ m. Bottom: enlarged images of indicated area in middle panel. Scale bar: 40 μ m. **(D)** Flow cytometry detection of intracellular levels of pNFKBIA(Ser 32,36) in cells preincubated with the indicated antibodies before seeding to rBM-coated culture plates for 16 h.

transfected with *siIKBK* and *siMAP3K7* to target the IKK pathway as well as with *siTSC2* to target the MTORC1 pathway. Moreover, nontargeting siRNA (*siCTRL*) and siRNA against the key autophagy regulator, *ATG7* (*siATG7*) were used as negative and positive controls, respectively. Cells were preincubated with anti-ITGA3 antibody and seeded onto laminin-rich rBM coated plates. After 16 h, the number of GFP-LC3 puncta per cell was

enumerated (**Fig. 6**). Cells expressing control siRNA exhibited numerous GFP-LC3 puncta in response to the block in ITGA3 function, which was potently suppressed upon ATG7 depletion. Moreover, the knockdown of IKBK and MAP3K7 significantly decreased GFP-LC3 puncta formation in response to ITGA3 function blocking antibody; in contrast, TSC2 depletion had minimal effects on GFP-LC3 puncta formation compared with

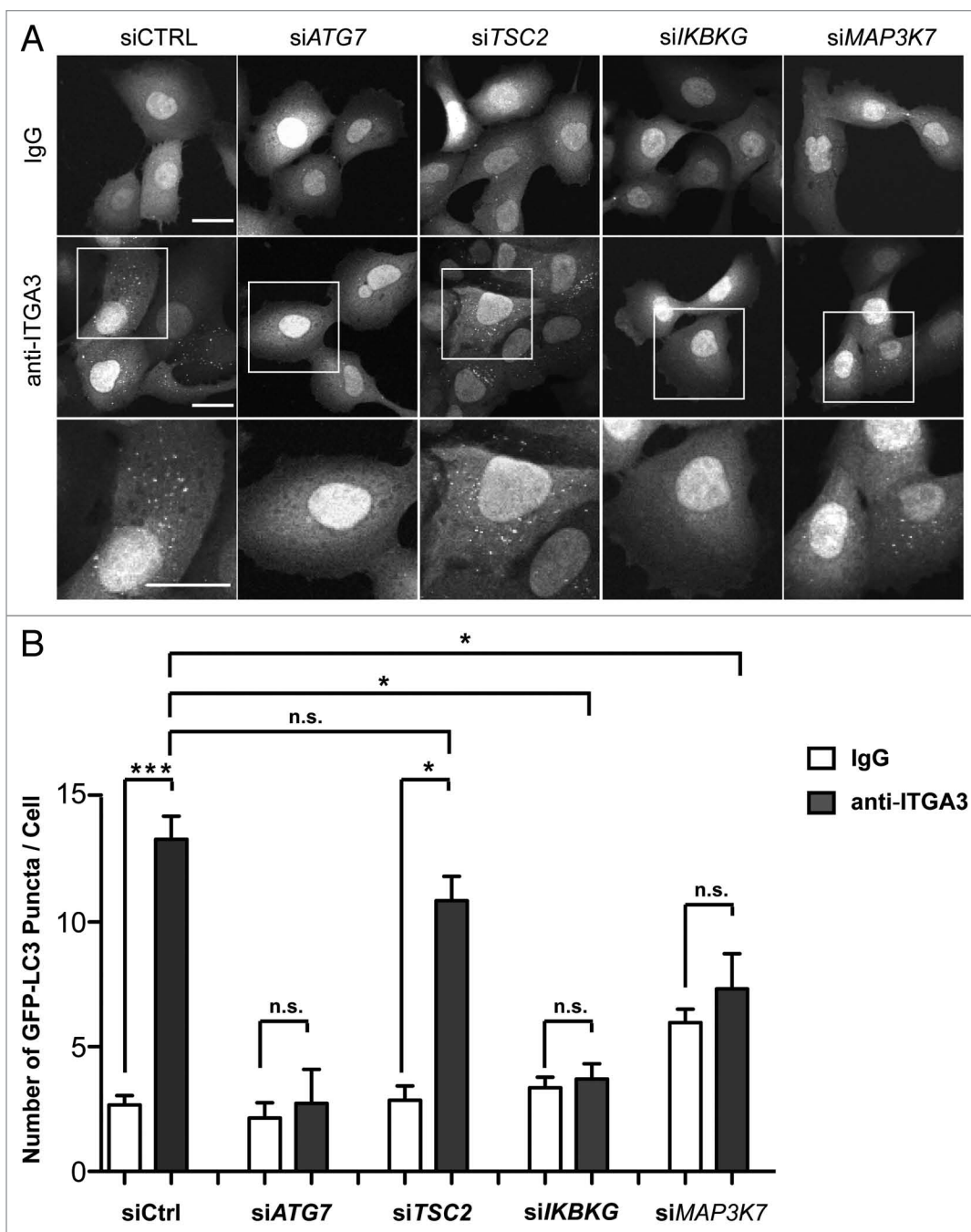

Figure 6. MAP3K7-IKK pathway promotes autophagy in MECs induced upon function blockade of ITGA3. **(A)** Confocal images of MCF10A cells expressing GFP-LC3 transfected with the indicated siRNAs, preincubated with IgG (top) or anti-ITGA3 antibody (middle), and seeded to rBM-coated culture plates for 16 h. Scale bar: 25 μ m. Bottom: Enlarged images of the indicated area in middle panel. Scale bar: 50 μ m. **(B)** Quantification of number of GFP-LC3 puncta per cell (mean \pm SEM). In total, 300 cells from three independent experiments were quantified.

cells expressing control siRNA. Together, these data indicated that the disruption of ITGA3-ITGB1 function causes IKK activation and autophagosome induction in MCF10A cells.

Pharmacological Inhibition of IKK activity enhances luminal apoptosis of MCF10A cells in 3D culture. Autophagy promotes cell survival during ECM detachment.⁴ Hence, we investigated whether IKK inhibition would enhance cell death in cells devoid of interaction with the ECM. MCF10A cells were

treated with varying doses of IKK inhibitor Bay-117082 and cultured in attached vs. detached conditions for 24 h, upon which apoptosis was monitored by immunoblotting for cleaved-PARP. As shown in **Figure 7A**, cleaved-PARP was only detected in detached cells, indicating ECM detachment induced anoikis in these cells. Interestingly, Bay-117082 treatment enhanced cleaved-PARP expression in a dose-dependent manner, confirming that IKK pathway inhibition enhanced apoptosis in suspended cells.

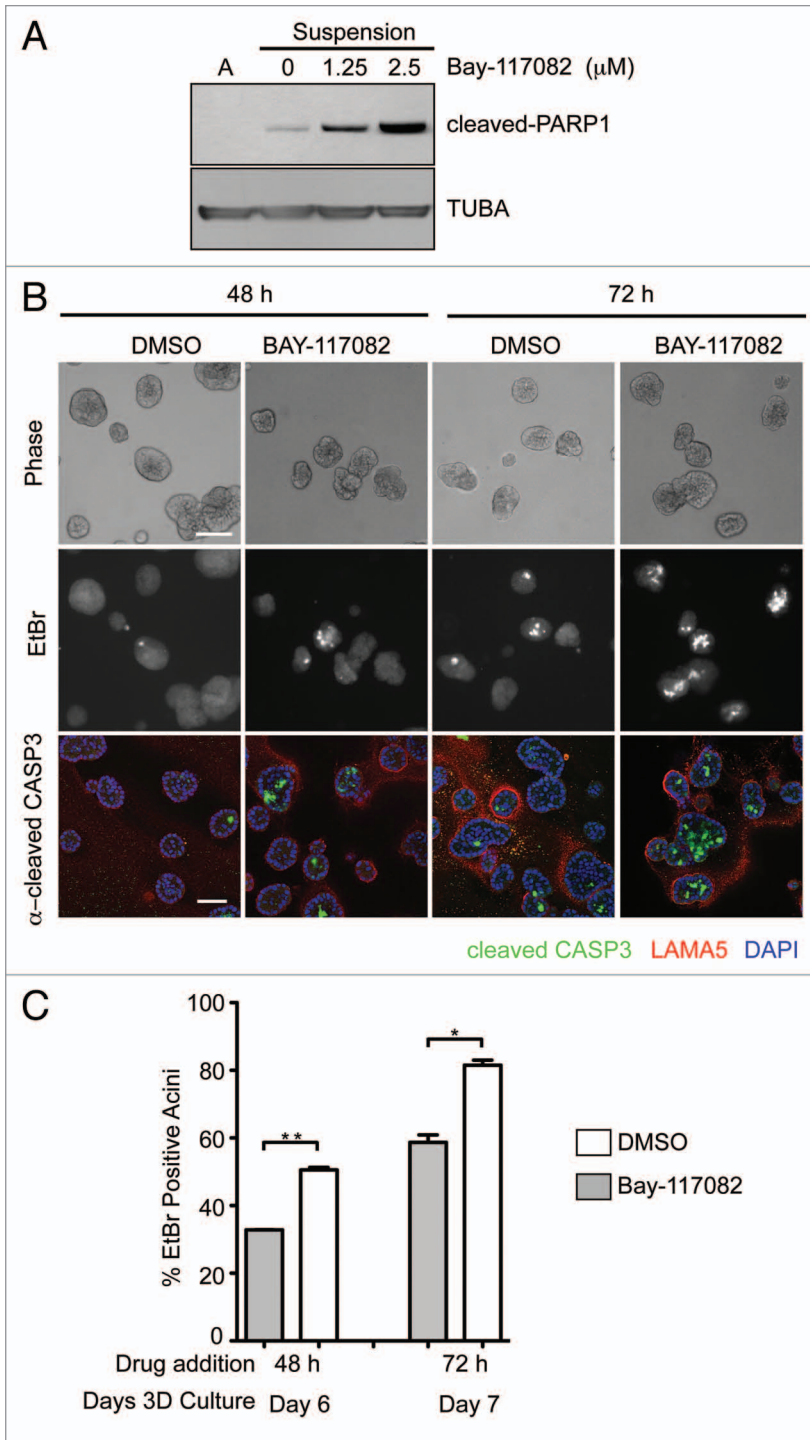

Figure 7. Inhibition of IKK enhances anoikis and luminal apoptosis in 3D culture. (A) MCF10A cells were cultured attached (A) or in suspension in the presence of DMSO control or Bay-117082 at the indicated doses. Cell lysates were subject to immunoblotting with indicated antibodies. (B) Top: Phase images of MCF10A cell in 3D culture treated with DMSO or 10 μM Bay-117082 for indicated period of time. Scale bar: 100 μm . Middle: Fluorescent images of EtBr staining of MCF10A cell 3D culture under indicated conditions. Bottom: Confocal images of cleaved-CASP3 staining of MCF10A cell 3D culture treated with indicated conditions. Scale bar: 50 μm . (C) Quantification of percentage of EtBr positive acini in MCF10A 3D culture under the indicated conditions (mean \pm SEM). In total, 300 acini from three independent experiments were quantified.

To further corroborate the effects of IKK inhibition on anoikis, we utilized a three-dimensional (3D) culture model in which MCF10A cells form spherical acini notable for a hollow lumen. In this model, the anoikis of cells deprived of ECM contact is a principal contributor to the selective cell death of centrally located cells during lumen formation.³³ MCF10A cells were grown in 3D culture for 4 d, a time point at which minimal luminal apoptosis is observed.³⁴ Thereafter, the cultures were acutely treated with Bay-117082, and cell death was monitored on subsequent days by staining with ethidium bromide (EtBr), a DNA-binding intravital dye incorporated into dying cells.³⁴ We observed increased EtBr staining within the centers of acini treated with Bay-117082 at both 48 h and 72 h. This correlated with increased cleaved-CASP3/caspase3 staining of cells occupying the luminal space following treatment with Bay-117082 (Fig. 7B). Quantification of the percentage of EtBr positive acini in control and Bay-117082 treated structures revealed that Bay-117082 significantly accelerated luminal cell death in 3D culture (Fig. 7C). Overall, these results corroborate that pharmacological IKK inhibition enhances anoikis and accelerates luminal apoptosis during MCF10A acinar morphogenesis in three-dimensional culture.

Discussion

Here, we demonstrated that ECM detachment induces autophagy in mouse fibroblasts and human mammary epithelial cells through distinct pathways. In MEFs, the reduced activation of PI3K-AKT-MTORC1 pathway is the principal mediator of ECM detachment-induced autophagy; as a result, sustained activation of the PI3K-AKT-MTORC1 pathway is sufficient to suppress autophagy in ECM deprived MEFs. On the other hand, the MAP3K7-IKK pathway is the major contributor to autophagy induction in MECs during ECM detachment. In addition, we uncover that the specific loss of ITGA3-ITGB1 function in MECs is sufficient to induce autophagy via IKK activation, thus linking the deactivation of integrin receptors to specific intracellular signals that direct autophagy induction. Furthermore, pharmacological inhibition of IKK enhances anoikis and accelerates luminal cell apoptosis in 3D cultures of MCF10A cells.

The importance of the PI3K-AKT-MTORC1 pathway in autophagy regulation is well established.³⁵ Various stimuli that inhibit PI3K-AKT-MTORC1 pathway also activate autophagy. Moreover, activation of the PI3K-AKT-MTORC1 pathway has also been associated with autophagy inhibition. An increase of class I PI3K products

(phosphatidylinositol 3,4-bisphosphate and phosphatidylinositol 3,4,5-triphosphate) reduces autophagy in HT-29 cells.³⁶ AKT activation also suppresses autophagy in apoptosis-deficient tumor cells.³⁷ Here, we demonstrated that activation of the PI3K-AKT-MTORC1 pathway is similarly sufficient to suppress detachment-induced autophagy in fibroblasts. In contrast, activation of the MAPK1/3 (ERK2/1 respectively) pathway does not potently suppress autophagy during ECM detachment (data not shown and ref. 38), indicating a unique role for the PI3K-AKT pathway in autophagy regulation in ECM-detached fibroblasts.

Importantly, we demonstrated a new functional requirement for the IKK complex in the stimulating detachment-induced autophagy in mammary epithelial cells (MECs). Recent work indicates that IKK activation induces autophagy in response to multiple known autophagy stimuli.⁸ We showed that inhibition of IKK activity can suppress autophagy even when TORC1 pathway activation is profoundly suppressed; based on this result, we construe that the IKK complex plays a direct and critical role in autophagy regulation in detached MECs. Consistent with previous studies,^{8,11} suppressing NFkB activity is not sufficient to prevent autophagy induction in suspended cells (Fig. S3), indicating that the IKK complex regulates detachment-induced autophagy via a NFkB independent pathway. Remarkably, the depletion of IKBKB and IKBKG, but not CHUK, significantly suppresses autophagy induction during ECM detachment. Although CHUK and IKBKB are closely related, these kinases target distinct substrates and have divergent biological roles.¹⁰ For example, CHUK and IKBKB are differentially involved in cytokine- and insulin-induced TORC1 activation.³⁹ Our work suggests that IKBKB has a more direct role in regulating autophagy in the context of ECM detachment. Notably, the IKK phosphorylation consensus DS Ψ XXS⁴⁰ is present in several autophagy molecules, including ULK2, RB1CC1/FIP200, ATG14 and KIAA0226/Rubicon. Hence, IKK complex may directly impact certain initiation steps during autophagosome induction. Alternatively, IKK activation may induce phosphorylation and degradation of negative regulators of autophagy, resulting in autophagy activation. The further scrutiny of the precise mechanisms through which IKK activation leads to autophagy induction in ECM detached cells remains an important topic for future study.

Notably, although our results reveal striking differences in the pathways regulating ECM detachment-induced autophagy in MEFs and MCF10A cells, we recognize that the distinct results observed in these two cell types may represent unique situations in which detachment-induced autophagy is principally triggered by a single pathway. Accordingly, we hypothesize that in most cells, including other epithelial cell types, the induction of autophagy during ECM-deprivation likely involves the integration of multiple signaling pathways, which potentially includes downregulation of TORC1 activity, stimulation of the IKK complex, as well as other pathways that presently remain undefined. Indeed, two important areas for further study include: (1) elaborating the larger repertoire of signals controlling detachment-induced autophagy, both TORC1-dependent and -independent; and (2) dissecting how these multiple signals are integrated to produce the overall autophagic response in ECM-deprived cells.

Moreover, we uncovered a new link between integrin receptor signaling and autophagy induction. The ITGA3-ITGB1 and ITGA6-ITGB4 integrin receptors have overlapping ligand-binding specificities, and both have been reported to have prosurvival functions in keratinocytes and epithelial cells.⁴¹ Based on antibody-mediated function blocking experiments, our studies point to the loss of ITGA3-ITGB1 receptor engagement as the specific trigger for autophagy induction. Furthermore, this blockade also causes a significant increase in NFkBIA phosphorylation, and RNAi-mediated depletion of IKBKG and MAP3K7 significantly inhibits autophagosome formation in response to the block in ITGA3 function. Altogether, these results support a model in which reduced ITGA3-ITGB1 function in detached cells stimulates autophagy via activation of the MAP3K7-IKK pathway.

Both the NFkB pathway and autophagy have been found to promote cell survival during ECM detachment.^{4,7} Our study demonstrates that pharmacological inhibition of IKK enhances anoikis and accelerates luminal cell apoptosis in 3D culture of mammary epithelial cells; we propose that increased cell death results from simultaneous suppression of NFkB targets and autophagy upon inhibition of the IKK complex, thereby increasing cell susceptibility to anoikis. Remarkably, the prosurvival functions of NFkB pathway and autophagy have both been implicated in the adhesion-independent growth and anoikis resistance of tumor cells.^{38,42-45} Because anoikis resistance is associated with cancer progression and metastasis, in future work, it will be important to further scrutinize whether IKK critically regulates detachment-induced autophagy in cancer cells as well as to ascertain if IKK inhibition can be exploited to inhibit cancer cell survival in foreign tissue environments.

Materials and Methods

Cell culture. *Tsc2*^{+/+} and *tsc2*^{-/-} MEFs were generously provided by Dr. David Kwiatkowski (Harvard Medical School) and cultured in DMEM containing 25 mM glucose (Invitrogen, 11965118) supplemented with 10% fetal bovine serum (Atlas Biologicals, FP-0500-A), penicillin and streptomycin (UCSF Cell Culture Facility, CCFGK004). MCF10A cells were cultured as described previously.³⁴ Stable cell lines were generated by selection with 2 μ g/ml Puromycin (Sigma, P7255) or 300 μ g/ml G418 (Sigma, A1720).

Antibodies and chemicals. The anti-LC3 antibody generated in our laboratory has been described previously and is now commercially available (EMD Millipore, ABC232).⁴ The following antibodies were purchased from Cell Signaling Technology: anti-TSC2 (3612), anti-phospho RPS6 ribosomal protein (Ser240/244) (2215), anti-RPS6 ribosomal protein (2217), anti-phospho-RPS6KB1/p70RPS6 Kinase (Thr389)(9234), anti-RPS6KB1/p70RPS6 Kinase (9202), anti-phospho-AKT(Ser473) (4058), anti-AKT (4685), anti-phospho-CHUK/IKK α (Ser176) and IKBKB/IKK β (Ser177) (2078), anti-IKBKG/IKK γ (2678), anti-phospho-NFkBIA/I κ B α (Ser32/36) (9246), anti-NFkBIA/I κ B α (4814), anti-cleaved-PARP (9532), anti-cleaved CASP3/Caspase 3 (9579). Other antibodies used include following: anti-TUBA/tubulin (Sigma, T6199), anti-HA (HA.11 Clone 16B12,

Covance, MMS-101R), anti-Flag (Sigma, F3165), anti-ITGB1/integrin β 1 (Developmental Studies Hybridoma Bank, A1B2), anti-ITGA3/integrin α 3 (P1B5, EMD Millipore, MAB1952), anti-ITGA6/integrin α 6 (G0H3, EMD Millipore, MAB1378), anti-ITGB4/Integrin β 4 (ASC8, EMD Millipore, MAB2059), anti-phospho-NFKBIA/I κ B α (Ser32/36) (Abcam, ab12135), anti-CHUK and IKBKB (IKK α / β) (Santa Cruz Biotechnology, sc-7607), anti-laminin5 (EMD Millipore, MAB19562). Chemicals used include: poly(2-hydroxyethyl methacrylate) (poly-HEMA) (Sigma, P3932), E64d (Sigma, E8640), pepstatin A (Sigma, P4265), Bay-117082 (Sigma, B5556).

DNA constructs. pcDNA *TSC2* was a generous gift from Dr. Brendan Manning (Harvard School of Public Health) and pBABE-*I κ B-SR* was a generous gift from Dr. Joan Brugge (Harvard Medical School). The following constructs were obtained from Addgene: pcDNA-*CHUK*^{K44M}/*IKK α* ^{K44M}-HA (plasmid 23297), pCR-Flag-*IKBKB*^{K44M}/*IKK β* ^{K44M} (plasmid 15466), pcDNA3-*FLAG-RHEB* (plasmid 19996).

Retroviral production. pWZLneo ER-AKT and pBABE-puro GFP-LC3 have been previously described.^{4,46} The retroviral vector pLNCX-neo containing active PIK3CA* (*PIK3CA*^{E545K}) was kindly provided by Dr. W. Weiss (University of California, San Francisco). *RHEB* was cloned into pMX-puro retroviral vector. *TSC2* WT and *TSC2*^{N1643I} were cloned into pBABE-puro retroviral vector. Retrovirus was generated using as previously described.³⁴

RNA interference. The following pooled small interfering RNA (siRNA) oligonucleotides (SMARTpool) against *TSC2* (L-003029-00-0005), *ATG7* (M-020112-01-0005), *IKBK* (L-003767-00-0005) and *MAP3K7* (L-003790-00-0005) were purchased from Dharmacon RNA Technologies. For siRNA transfection, 2×10^6 MCF10A cells were transfected with 200 nM siRNA using Amaxa nucleofector kit V (Lonza, VCA-1003). After 36 to 48 h, cells were utilized for substratum detachment assays or antibody-mediated blockade of integrin subunit function.⁴

Substratum detachment assays. MCF10A cells were cultured attached or suspended as previously described.^{4,47} Briefly, tissue culture plates coated with 6 mg/ml poly-HEMA in 95% ethanol were incubated at 37°C until dry. Cells were subsequently plated on poly-HEMA-coated plates in their appropriate growth medium. To detect cleaved-PARP during anoikis, MCF10A cells were cultured in suspension for indicated times in DMEM/F12 media containing 0.5% horse serum (Invitrogen, 16050-114), 0.5 μ g/ml hydrocortisone (Sigma, H0888), 100 ng/ml cholera toxin (Sigma, C8052), penicillin and streptomycin.

To evaluate autophagic flux, the lysosomal inhibitors, E64d and pepstatin A (E/P), were added directly to the culture media at 10 μ g/ml at 6 h before lysis. Lysates were resolved by SDS-PAGE, subject to anti-MAP1LC3A and anti-TUBA immunoblotting, and the levels of cleaved and PE-lipidated LC3-II and TUBA were quantified using densitometry. The change in the LC3-II/TUBA ratio in the presence of E/P between detached and suspended conditions was used to assess autophagic flux; in addition, the levels of LC3-II/TUBA during suspension in the presence of E/P (lanes corresponding S + E/P) were directly compared with assess the overall capacity for autophagy induction upon detachment.

Immunoprecipitation. MCF10A cells grown attached or suspended for 24 h were lysed in Triton lysis buffer (0.5% Triton (v/v), 150 mM NaCl, 20 mM Tris pH 7.5, 2 mM EDTA pH 8.0) containing protease inhibitors cocktail (Sigma, P8340), 10 mM NaF (Sigma, S6776), 10 mM β -glycerophosphate (Sigma, G9422) 1 mM Na₃VO₃ (Sigma, S6508) and 10 nM calyculin A (Sigma, C5552). Lysates were homogenized with a Dounce homogenizer (Fisher Scientific, K885300-0002) and incubated on ice for 30 min. Subsequently, the lysates were cleared by centrifuge for 20 min at 4°C. 1 mg of each cell lysate was pre-cleared with protein A/G agarose (Santa Cruz, sc-2003) at 4°C for 1 h and incubated with 10 μ g/ml of anti-CHUK and IKBKB (IKK α / β) antibody overnight at 4°C. Subsequently, protein A/G agarose was added to lysate and incubated for 2 h at 4°C; the immune complex-containing agarose beads were recovered by centrifugation, washed 3 times with cold lysis buffer containing protease and phosphatase inhibitors, and subject to SDS-PAGE and immunoblot analysis.

Flow cytometry. Cells were harvested and fixed in 4% paraformaldehyde followed by resuspension in cold 90% methanol for 30 min on ice. Cells were then subject to antibody staining according to manufacturew's protocol. Anti-phospho-NFKBIA/I κ B α (Ser32/36) (Abcam, ab12135) was used at 1:100 dilution.

Antibody-mediated blockade of integrin subunit function. Tissue culture plates or coverslips were coated with 1% laminin rich reconstituted basement membrane (v/v) (Matrigel, BD Bioscience, 354234) in PBS at 37°C for 16 h. MCF10A cells were trypsinized and resuspended in 100 μ l full growth media at 1×10^6 /ml. The indicated anti-integrin subunit antibodies or isotype controls were added to cell suspension at final concentration of 20 μ g/ml. Cells were incubated on ice for 30 min, diluted with full culture media and seeded to rBM (Matrigel)-coated tissue culture plates or coverslips. After 16 to 24 h, cells were harvested for experiments.

Three-dimensional culture assays. MCF10A 3D cultures were performed and processed for ethidium bromide (EtBr) staining or confocal microscopy as described previously.³⁴ When indicated, 10 μ M Bay-117082 was added to 3D cultures on day 4 for 48 and 72 h before fixation.

Image acquisition and analysis. Phase images of 3D culture were acquired on an Axiovert 200 microscope (Carl Zeiss Microscopy) equipped with a Spot RT camera (Diagnostic Instruments). For confocal analyses, images were acquired using a C1Si confocal laser-scanning microscope (Nikon) and analyzed using EZ-C1 software (v3.20) (Nikon) and MetaMorph software (v6.0) (MetaMorph software, GE Healthcare). 3D cultures were fixed and stained as previously described.³⁴

Statistical analysis. Graphs represent the average values from three independent experiments with error bars reflecting the standard error of the mean. GraphPad Prism software (v5.0b) (GraphPad Software) was used for statistical analysis. p values were determined by unpaired Student's t-test with p < 0.05 considered significant.

Disclosure of Potential Conflicts of Interest

No potential conflicts of interest were disclosed.

We thank Drs. Joan Brugge, David Kwiatkowski, Brendan Manning and William Weiss for reagents and other members of the Debnath laboratory for helpful discussions. Grant support to J.D. includes the NIH (RO1 CA126792 and ARRA supplement CA126792-S1) and the DOD BCRP (W81XWH-11-1-0130).

Supplemental materials may be found here:
www.landesbioscience.com/journals/autophagy/article/24870

References

- Gilmore AP, Anoiakis. Cell Death Differ 2005; 12(Suppl 2):1473-7; PMID:16247493; <http://dx.doi.org/10.1038/sj.cdd.4401723>
- Frisch SM, Francis H. Disruption of epithelial cell-matrix interactions induces apoptosis. J Cell Biol 1994; 124:619-26; PMID:8106557; <http://dx.doi.org/10.1083/jcb.124.4.619>
- Debnath J, Brugge JS. Modelling glandular epithelial cancers in three-dimensional cultures. Nat Rev Cancer 2005; 5:675-88; PMID:16148884; <http://dx.doi.org/10.1038/nrc1695>
- Fung C, Lock R, Gao S, Salas E, Debnath J. Induction of autophagy during extracellular matrix detachment promotes cell survival. Mol Biol Cell 2008; 19:797-806; PMID:18094039; <http://dx.doi.org/10.1091/mbc.E07-10-1092>
- He C, Klionsky DJ. Regulation mechanisms and signaling pathways of autophagy. Annu Rev Genet 2009; 43:67-93; PMID:19653858; <http://dx.doi.org/10.1146/annurev-genet-102808-114910>
- Avivar-Valderas A, Bobrovnikova-Marjon E, Alan Diehl J, Bardeesy N, Debnath J, Aguirre-Ghiso JA. Regulation of autophagy during ECM detachment is linked to a selective inhibition of mTORC1 by PERK. Oncogene 2012; PMID:23160380; <http://dx.doi.org/10.1038/ncr.2012.512>
- Yan SR, Joseph RR, Rosen K, Reginato MJ, Jackson A, Allaire N, et al. Activation of NF-kappaB following detachment delays apoptosis in intestinal epithelial cells. Oncogene 2005; 24:6482-91; PMID:16007176
- Criollo A, Senovilla L, Authier H, Maiuri MC, Morselli E, Vitale I, et al. The IKK complex contributes to the induction of autophagy. EMBO J 2010; 29:619-31; PMID:19959994; <http://dx.doi.org/10.1038/emboj.2009.364>
- Siebenlist U, Franzoso G, Brown K. Structure, regulation and function of NF-kappa B. Annu Rev Cell Biol 1994; 10:405-55; PMID:7888182; <http://dx.doi.org/10.1146/annurev.cb.10.110194.002201>
- Chariot A. The NF-kappaB-independent functions of IKK subunits in immunity and cancer. Trends Cell Biol 2009; 19:404-13; PMID:19648011; <http://dx.doi.org/10.1016/j.tcb.2009.05.006>
- Comb WC, Cogswell P, Sitcheran R, Baldwin AS. IKK-dependent, NF-kB-independent control of autophagic gene expression. Oncogene 2011; 30:1727-32; PMID:21151171; <http://dx.doi.org/10.1038/ncr.2010.553>
- Kim JE, You DJ, Lee C, Ahn C, Seong JY, Hwang JI. Suppression of NF-kappaB signaling by KEAP1 regulation of IKKbeta activity through autophagic degradation and inhibition of phosphorylation. Cell Signal 2010; 22:1645-54; PMID:20600852; <http://dx.doi.org/10.1016/j.cellsig.2010.06.004>
- Niida M, Tanaka M, Kamitani T. Downregulation of active IKK beta by Ro52-mediated autophagy. Mol Immunol 2010; 47:2378-87; PMID:20627395; <http://dx.doi.org/10.1016/j.molimm.2010.05.004>
- Magnuson B, Ekim B, Fingar DC. Regulation and function of ribosomal protein S6 kinase (S6K) within mTOR signalling networks. Biochem J 2012; 441:1-21; PMID:22168436; <http://dx.doi.org/10.1042/BJ20110892>
- Kwiatkowski DJ. Tuberous sclerosis: from tubers to mTOR. Ann Hum Genet 2003; 67:87-96; PMID:12556239; <http://dx.doi.org/10.1046/j.1469-1809.2003.00012.x>
- Manning BD, Tee AR, Logsdon MN, Blenis J, Cantley LC. Identification of the tuberous sclerosis complex-2 tumor suppressor gene product tuberlin as a target of the phosphoinositide 3-kinase/akt pathway. Mol Cell 2002; 10:151-62; PMID:12150915; [http://dx.doi.org/10.1016/S1097-2765\(02\)00568-3](http://dx.doi.org/10.1016/S1097-2765(02)00568-3)
- Inoki K, Li Y, Zhu T, Wu J, Guan KL. TSC2 is phosphorylated and inhibited by Akt and suppresses mTOR signalling. Nat Cell Biol 2002; 4:648-57; PMID:12172553; <http://dx.doi.org/10.1038/ncb839>
- Urano J, Sato T, Matsuo T, Otsubo Y, Yamamoto M, Tamanoi F. Point mutations in TOR confer Rheb-independent growth in fission yeast and nutrient-independent mammalian TOR signaling in mammalian cells. Proc Natl Acad Sci U S A 2007; 104:3514-9; PMID:17360675; <http://dx.doi.org/10.1073/pnas.0608510104>
- Sancak Y, Thoreen CC, Peterson TR, Lindquist RA, Kang SA, Spooner E, et al. PRAS40 is an insulin-regulated inhibitor of the mTORC1 protein kinase. Mol Cell 2007; 25:903-15; PMID:17386266; <http://dx.doi.org/10.1016/j.molcel.2007.03.003>
- Kovacina KS, Park GY, Bae SS, Guzzetta AW, Schaefer E, Birnbaum MJ, et al. Identification of a proline-rich Akt substrate as a 14-3-3 binding partner. J Biol Chem 2003; 278:10189-94; PMID:12524439; <http://dx.doi.org/10.1074/jbc.M210837200>
- Pierce JW, Schoenleber R, Jesmok G, Best J, Moore SA, Collins T, et al. Novel inhibitors of cytokine-induced IkkappaBalpha phosphorylation and endothelial cell adhesion molecule expression show anti-inflammatory effects in vivo. J Biol Chem 1997; 272:21096-103; PMID:9261113; <http://dx.doi.org/10.1074/jbc.272.34.21096>
- Gelezianus R, Ferrell S, Lin X, Mu Y, Cunningham ET Jr., Grant M, et al. Human T-cell leukemia virus type 1 Tax induction of NF-kappaB involves activation of the IkkappaB kinase α (IKKalpha) and IKKbeta cellular kinases. Mol Cell Biol 1998; 18:5157-65; PMID:9710600
- Nakano H, Shindo M, Sakon S, Nishinaka S, Mihara M, Yagita H, et al. Differential regulation of IkkappaB kinase α and β by two upstream kinases, NF-kappaB-inducing kinase and mitogen-activated protein kinase/ERK kinase-1. Proc Natl Acad Sci U S A 1998; 95:3537-42; PMID:9520401; <http://dx.doi.org/10.1073/pnas.95.7.3537>
- Skaug B, Jiang X, Chen ZJ. The role of ubiquitin in NF-kappaB regulatory pathways. Annu Rev Biochem 2009; 78:769-96; PMID:19489733; <http://dx.doi.org/10.1146/annurev.biochem.78.070907.102750>
- Brown K, Gerstberger S, Carlson L, Franzoso G, Siebenlist U. Control of I kappa B-alpha proteolysis by site-specific, signal-induced phosphorylation. Science 1995; 267:1485-8; PMID:7878466; <http://dx.doi.org/10.1126/science.7878466>
- Kim C, Ye F, Ginsberg MH. Regulation of integrin activation. Annu Rev Cell Dev Biol 2011; 27:321-45; PMID:21663444; <http://dx.doi.org/10.1146/annurev-cellbio.100109-104104>
- Ruoslahti E. RGD and other recognition sequences for integrins. Annu Rev Cell Dev Biol 1996; 12:697-715; PMID:8970741; <http://dx.doi.org/10.1146/annurev.cellbio.12.1.697>
- Nishiuchi R, Takagi J, Hayashi M, Ido H, Yagi Y, Sanzen N, et al. Ligand-binding specificities of laminin-binding integrins: a comprehensive survey of laminin-integrin interactions using recombinant $\alpha 3 \beta 1$, $\alpha 6 \beta 1$, $\alpha 7 \beta 1$ and $\alpha 6 \beta 4$ integrins. Matrix Biol 2006; 25:189-97; PMID:16413178; <http://dx.doi.org/10.1016/j.matbio.2005.12.001>
- Carter WG, Wayner EA, Bouchard TS, Kaur P. The role of integrins $\alpha 2 \beta 1$ and $\alpha 3 \beta 1$ in cell-cell and cell-substrate adhesion of human epidermal cells. J Cell Biol 1990; 110:1387-404; PMID:1691191; <http://dx.doi.org/10.1083/jcb.110.4.1387>
- Werb Z, Tremble PM, Behrendtsen O, Crowley E, Damsky CH. Signal transduction through the fibronectin receptor induces collagenase and stromelysin gene expression. J Cell Biol 1989; 109:877-89; PMID:2547805; <http://dx.doi.org/10.1083/jcb.109.2.877>
- Dedhar S, Jewell K, Rojiani M, Gray V. The receptor for the basement membrane glycoprotein entactin is the integrin $\alpha 3 \beta 1$. J Biol Chem 1992; 267:18908-14; PMID:1527019
- Egles C, Huet HA, Dogan F, Cho S, Dong S, Smith A, et al. Integrin-blocking antibodies delay keratinocyte re-epithelialization in a human three-dimensional wound healing model. PLoS One 2010; 5:e10528; PMID:20502640; <http://dx.doi.org/10.1371/journal.pone.0010528>
- Debnath J, Mills KR, Collins NL, Reginato MJ, Muthuswamy SK, Brugge JS. The role of apoptosis in creating and maintaining luminal space within normal and oncogene-expressing mammary acini. Cell 2002; 111:29-40; PMID:12372298; [http://dx.doi.org/10.1016/S0092-8674\(02\)01001-2](http://dx.doi.org/10.1016/S0092-8674(02)01001-2)
- Debnath J, Muthuswamy SK, Brugge JS. Morphogenesis and oncogenesis of MCF-10A mammary epithelial acini grown in three-dimensional basement membrane cultures. Methods 2003; 30:256-68; PMID:12798140; [http://dx.doi.org/10.1016/S1046-2023\(03\)00032-X](http://dx.doi.org/10.1016/S1046-2023(03)00032-X)
- Jung CH, Ro SH, Cao J, Otto NM, Kim DH. mTOR regulation of autophagy. FEBS Lett 2010; 584:1287-95; PMID:20083114; <http://dx.doi.org/10.1016/j.febslet.2010.01.017>
- Petiot A, Ogier-Denis E, Blommaert EF, Meijer AJ, Codogno P. Distinct classes of phosphatidylinositol 3'-kinases are involved in signaling pathways that control macroautophagy in HT-29 cells. J Biol Chem 2000; 275:992-8; PMID:10625637; <http://dx.doi.org/10.1074/jbc.275.2.992>
- Degenhardt K, Mathew R, Beaudoin B, Bray K, Anderson D, Chen G, et al. Autophagy promotes tumor cell survival and restricts necrosis, inflammation, and tumorigenesis. Cancer Cell 2006; 10:51-64; PMID:16843265; <http://dx.doi.org/10.1016/j.ccr.2006.06.001>
- Lock R, Roy S, Kenific CM, Su JS, Salas E, Ronen SM, et al. Autophagy facilitates glycolysis during Ras-mediated oncogenic transformation. Mol Biol Cell 2011; 22:165-78; PMID:21119005; <http://dx.doi.org/10.1091/mbc.E10-06-0500>
- Dan HC, Baldwin AS. Differential involvement of IkkappaB kinases α and β in cytokine- and insulin-induced mammalian target of rapamycin activation determined by Akt. J Immunol 2008; 180:7582-9; PMID:18490760
- Karin M, Ben-Neriah Y. Phosphorylation meets ubiquitination: the control of NF- κ B activity. Annu Rev Immunol 2000; 18:621-63; PMID:10837071; <http://dx.doi.org/10.1146/annurev.immunol.18.1.621>

41. Friedland JC, Lakins JN, Kazanietz MG, Chernoff J, Boettiger D, Weaver VM. $\alpha 6\beta 4$ integrin activates Rac-dependent p21-activated kinase 1 to drive NF- κ B-dependent resistance to apoptosis in 3D mammary acini. *J Cell Sci* 2007; 120:3700-12; PMID:17911169; <http://dx.doi.org/10.1242/jcs.03484>
42. Weaver VM, Lelièvre S, Lakins JN, Chrenek MA, Jones JC, Giancotti F, et al. $\beta 4$ integrin-dependent formation of polarized three-dimensional architecture confers resistance to apoptosis in normal and malignant mammary epithelium. *Cancer Cell* 2002; 2:205-16; PMID:12242153; [http://dx.doi.org/10.1016/S1535-6108\(02\)00125-3](http://dx.doi.org/10.1016/S1535-6108(02)00125-3)
43. Scaife CL, Kuang J, Wills JC, Trowbridge DB, Gray P, Manning BM, et al. Nuclear factor κ B inhibitors induce adhesion-dependent colon cancer apoptosis: implications for metastasis. *Cancer Res* 2002; 62:6870-8; PMID:12460901
44. Chen N, Eritja N, Lock R, Debnath J. Autophagy restricts proliferation driven by oncogenic phosphatidylinositol 3-kinase in three-dimensional culture. *Oncogene* 2012; PMID:22777351; <http://dx.doi.org/10.1038/onc.2012.277>
45. Gong C, Bauvy C, Tonelli G, Yue W, Deloménie C, Nicolas V, et al. Beclin 1 and autophagy are required for the tumorigenicity of breast cancer stem-like/progenitor cells. *Oncogene* 2013; 32:2261-72; PMID:22733132; <http://dx.doi.org/10.1038/onc.2012.252>
46. Debnath J, Walker SJ, Brugge JS. Akt activation disrupts mammary acinar architecture and enhances proliferation in an mTOR-dependent manner. *J Cell Biol* 2003; 163:315-26; PMID:14568991; <http://dx.doi.org/10.1083/jcb.200304159>
47. Debnath J. Detachment-induced autophagy in three-dimensional epithelial cell cultures. *Methods Enzymol* 2009; 452:423-39; PMID:19200896; [http://dx.doi.org/10.1016/S0076-6879\(08\)03625-2](http://dx.doi.org/10.1016/S0076-6879(08)03625-2)