



# ESD Repair of Army Main Battle Tank Components

January 26, 2006

Presented by: Phillip Leyman

Victor Champagne (vchampag@arl.army.mil; 410-306-0822)

Marc Pepi (marc.pepi@arl.army.mil; 410-306-0848)

Army Research Laboratory, APG, MD

Tony Pollard and Phil Coleman

Anniston Army Depot

# Report Documentation Page

*Form Approved*  
*OMB No. 0704-0188*

Public reporting burden for the collection of information is estimated to average 1 hour per response, including the time for reviewing instructions, searching existing data sources, gathering and maintaining the data needed, and completing and reviewing the collection of information. Send comments regarding this burden estimate or any other aspect of this collection of information, including suggestions for reducing this burden, to Washington Headquarters Services, Directorate for Information Operations and Reports, 1215 Jefferson Davis Highway, Suite 1204, Arlington VA 22202-4302. Respondents should be aware that notwithstanding any other provision of law, no person shall be subject to a penalty for failing to comply with a collection of information if it does not display a currently valid OMB control number.

1. REPORT DATE <b>26 JAN 2006</b>	2. REPORT TYPE	3. DATES COVERED <b>00-00-2006 to 00-00-2006</b>			
4. TITLE AND SUBTITLE <b>ESD Repair of Army Main Battle Tank Components</b>		5a. CONTRACT NUMBER			
		5b. GRANT NUMBER			
		5c. PROGRAM ELEMENT NUMBER			
6. AUTHOR(S)		5d. PROJECT NUMBER			
		5e. TASK NUMBER			
		5f. WORK UNIT NUMBER			
7. PERFORMING ORGANIZATION NAME(S) AND ADDRESS(ES) <b>U. S. Army Research Laboratory, Aberdeen Proving Ground, MD, 21005</b>		8. PERFORMING ORGANIZATION REPORT NUMBER			
9. SPONSORING/MONITORING AGENCY NAME(S) AND ADDRESS(ES)		10. SPONSOR/MONITOR'S ACRONYM(S)			
		11. SPONSOR/MONITOR'S REPORT NUMBER(S)			
12. DISTRIBUTION/AVAILABILITY STATEMENT <b>Approved for public release; distribution unlimited</b>					
13. SUPPLEMENTARY NOTES <b>26th Replacement of Hard Chrome and Cadmium Plating Program Review Meeting, January 24-26, 2006, San Diego, CA. Sponsored by SERDP/ESTCP.</b>					
14. ABSTRACT					
15. SUBJECT TERMS					
16. SECURITY CLASSIFICATION OF:			17. LIMITATION OF ABSTRACT <b>Same as Report (SAR)</b>	18. NUMBER OF PAGES <b>27</b>	19a. NAME OF RESPONSIBLE PERSON
a. REPORT <b>unclassified</b>	b. ABSTRACT <b>unclassified</b>	c. THIS PAGE <b>unclassified</b>			



# Outline

- **ESD applications (ARL and ANAD)**
  - **ESD accomplishments**
  - **Repair of M1A1 tank cannon cradle**
    - Optimization of process
    - Preparation of DEM/VAL
    - Successful field repairs
  - **Repair of M1A1 tank sun gear shaft**
    - Process parameters optimized
    - Preparation of DEM/VAL
    - Formation of "Halo Effect"; inconsistent results and problems due to chrome plating. Effort focused on damage through chrome plating into AISI 9310 base metal.



# Army ESD Accomplishments

- Training completed at Anniston Army Depot (ANAD).
- Training held at ARL with Boeing, Sikorsky, ANAD and ARL in attendance.
- Component-specific training held at ARL by Advanced Surfaces and Processes, Inc. (ASAP) with ANAD in attendance.
- ARL and ANAD have completed procedure and repair of M1A1 Cannon Cradle and M1A1 helical gearshaft ("Sun Gear")



# Repair of M1 Sun Gear Shaft

- Small corrosion pits and wear marks noted on chrome plated surfaces on the exterior and interior of the Sun Gear Shaft. Some damage extends into base metal
- Shaft is AISI 9310 steel with chrome plating in some regions.
- Shaft is part of the RGB (Reduction Gear Box), which transmits power from the M1's turbine engine to the transmission.
- The Sun Gear Shaft has an input RPM of 32,000, and drives a planetary gear with an output of 3,000 RPM.
- The seals which ride on the chrome plated surfaces are carbon based spring loaded seals, providing very low levels of wear to this part.



# M1 Turbine Engine and Reduction Gear Box

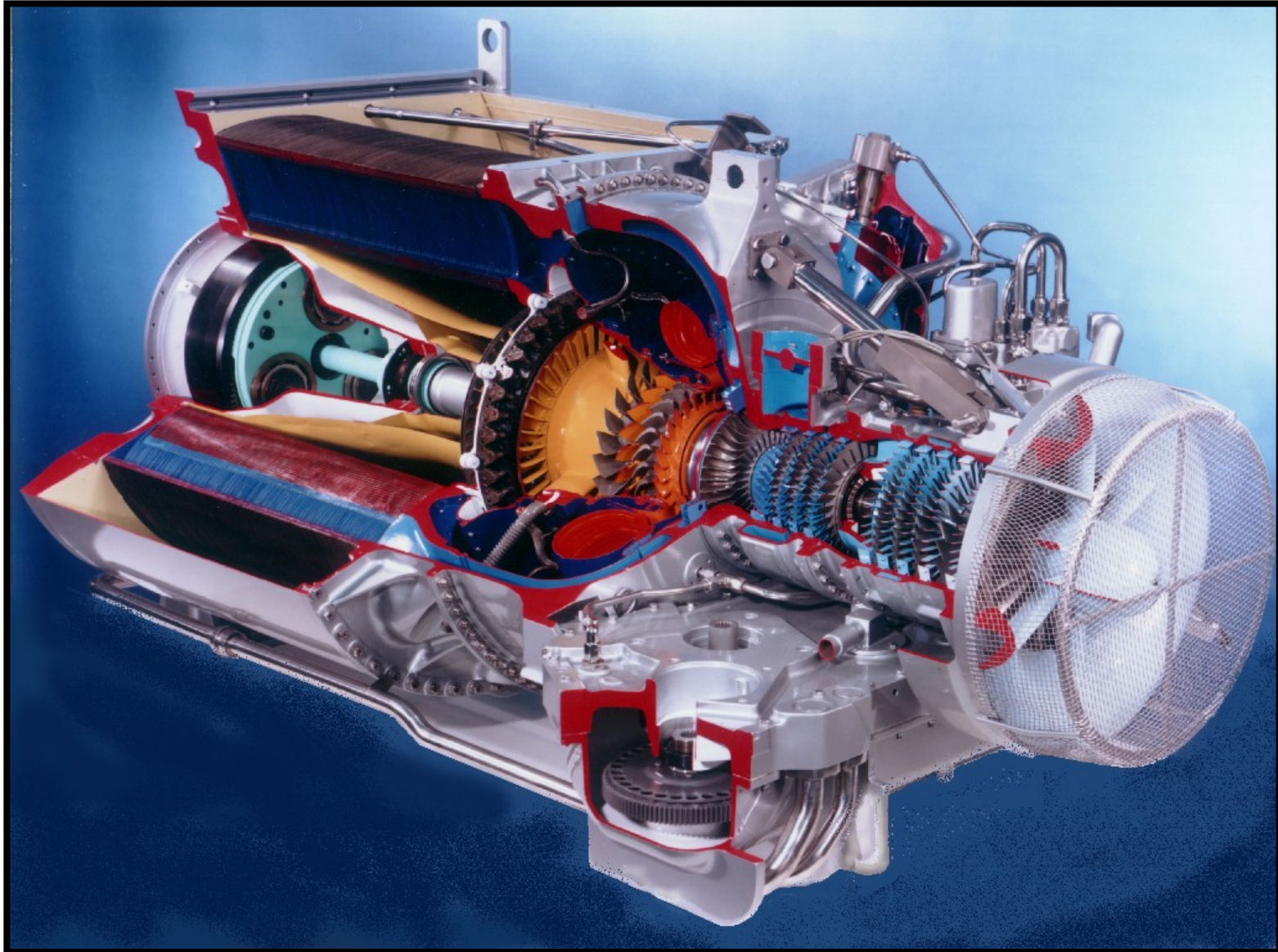



# Placement of Sun Gear Shaft in M1 Engine and RGB

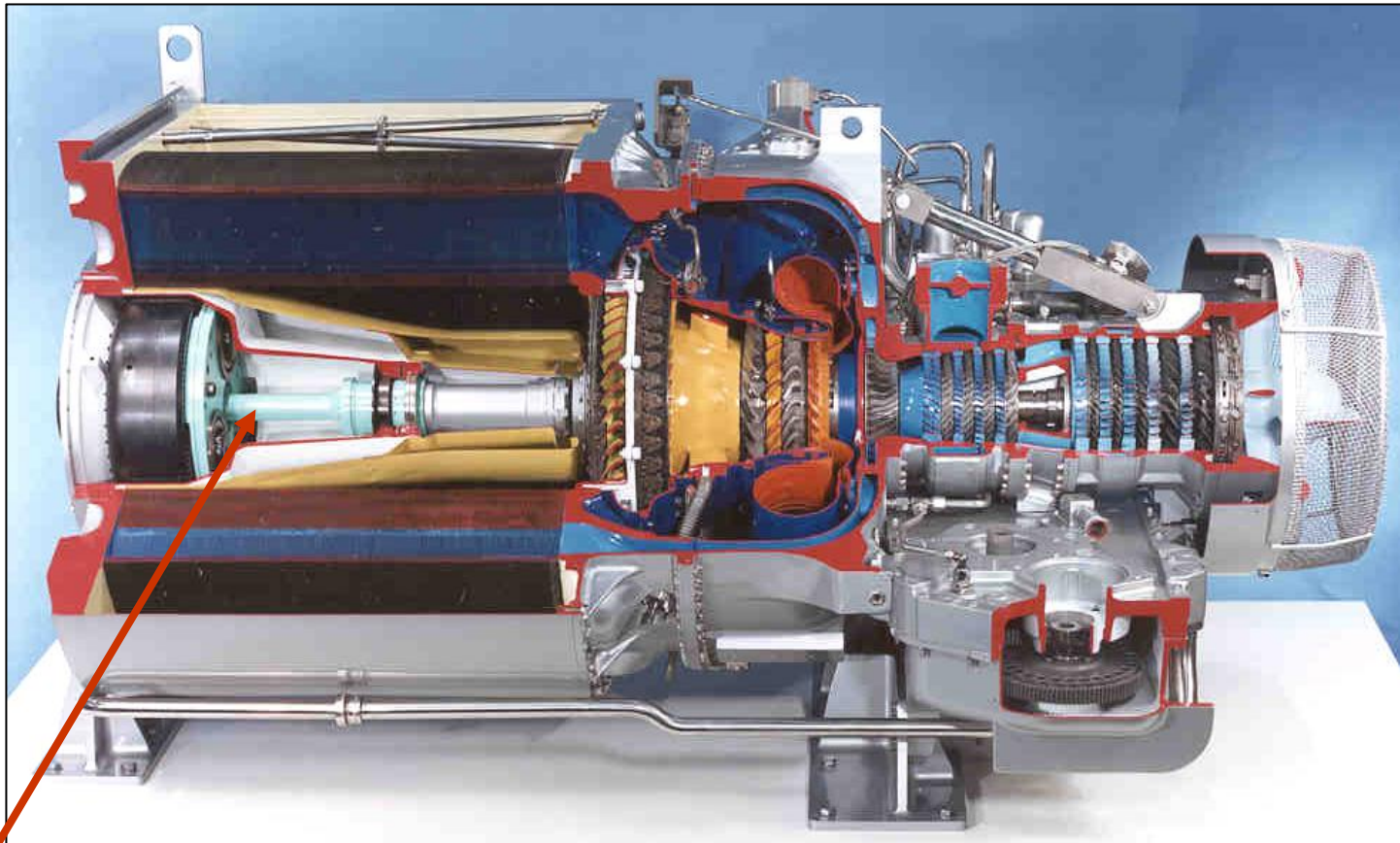

**Sun Gear Shaft**



# Cut-Away of M1 Reduction Gear Box

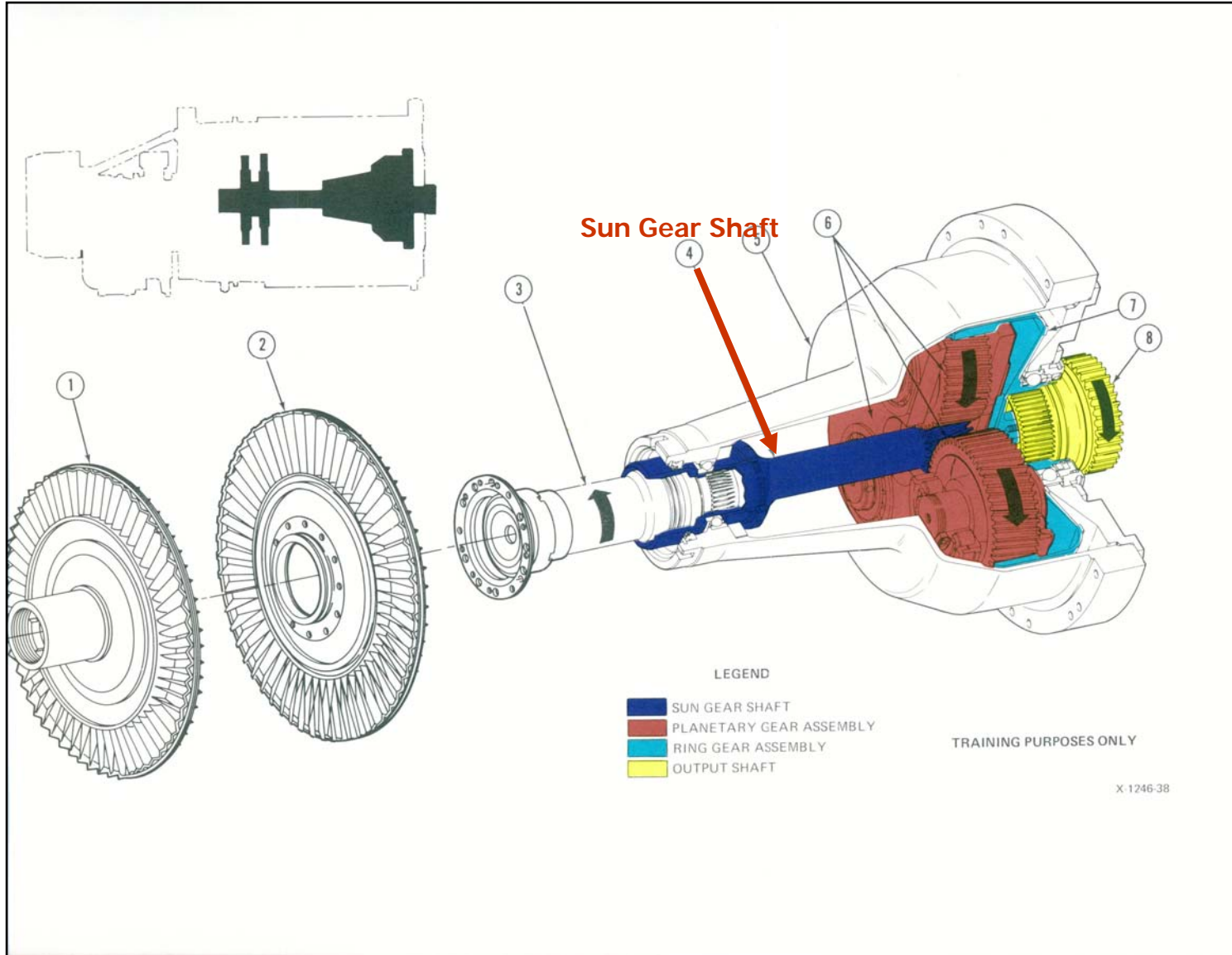



# Photograph of M1 Sun Gear Shaft

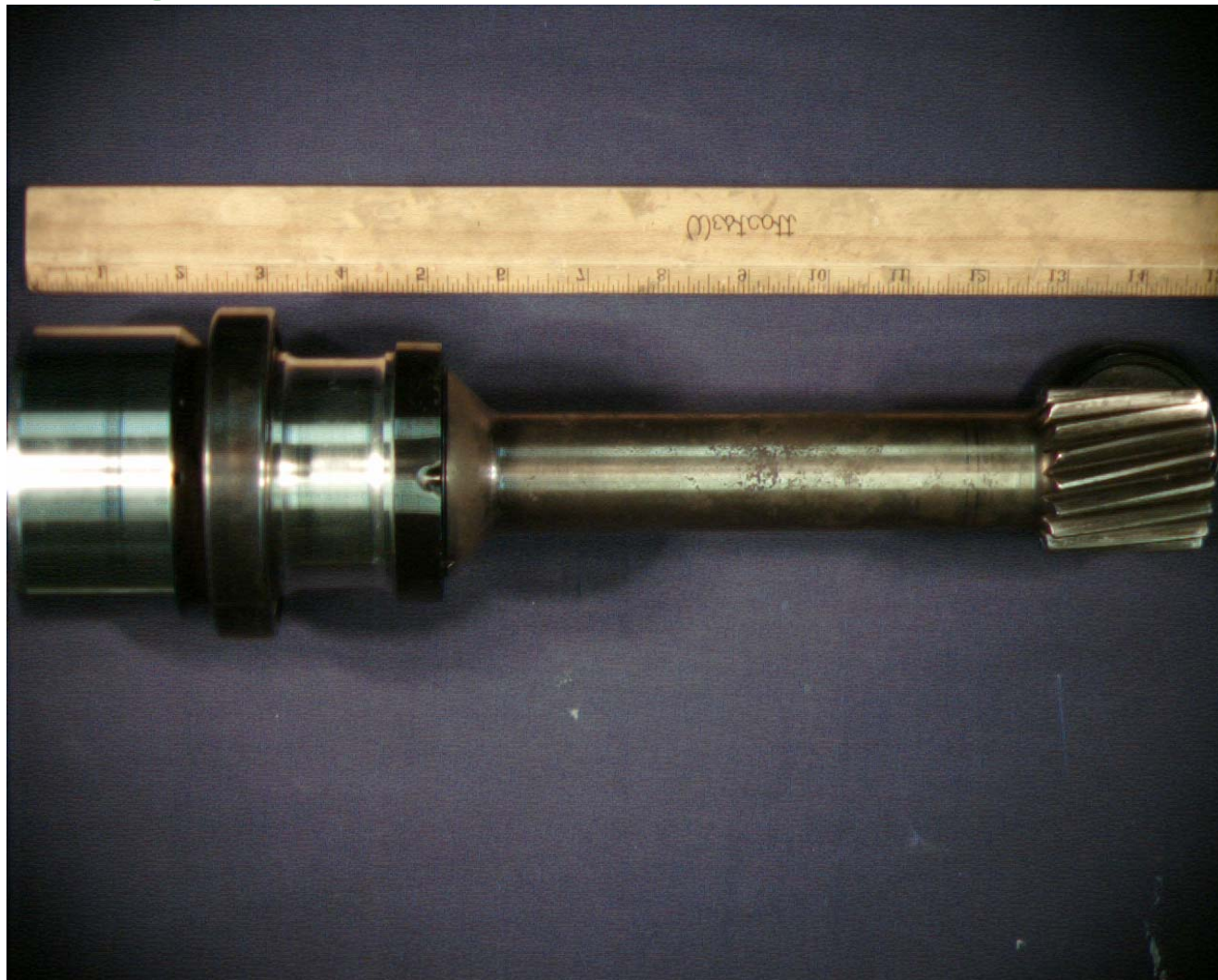



# Exterior Chrome Plating on M1 Sun Gear Shaft

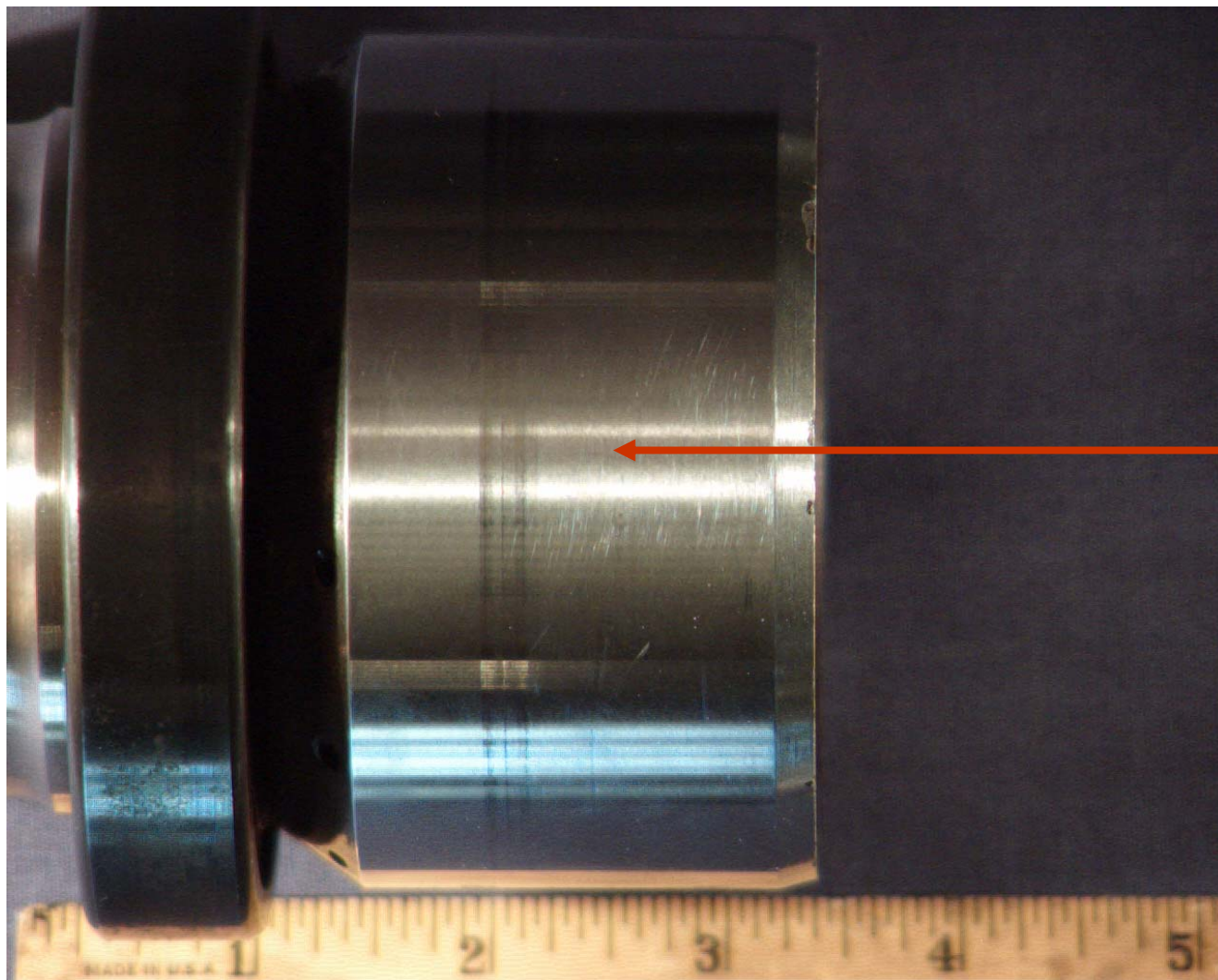

**Chrome  
Plating**



# Interior Chrome Plating on M1 Sun Gear Shaft

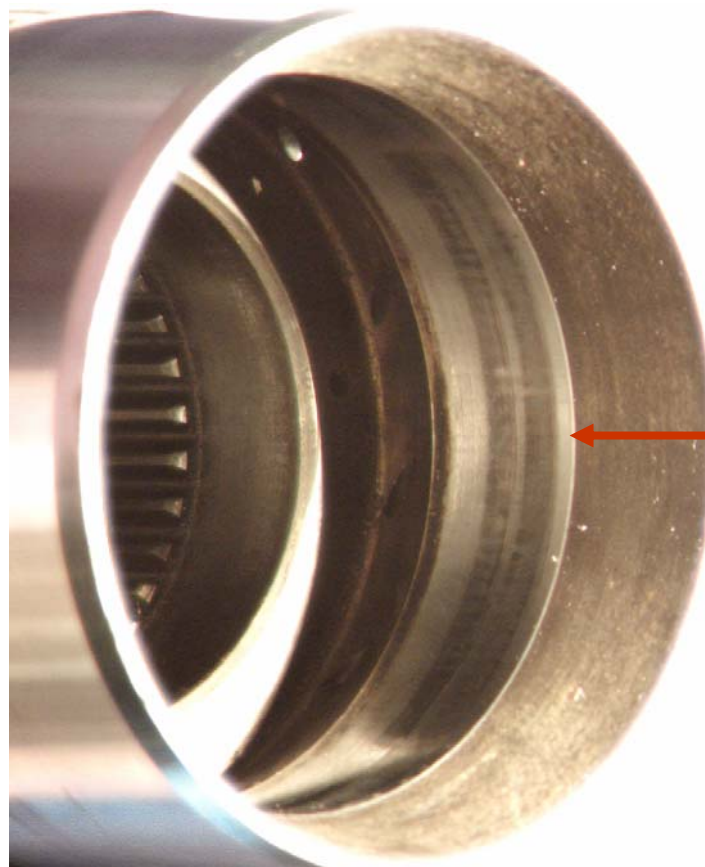

← **Chrome  
Plating**



# Corrosion Pits on M1 Sun Gear Shaft Chrome Plating

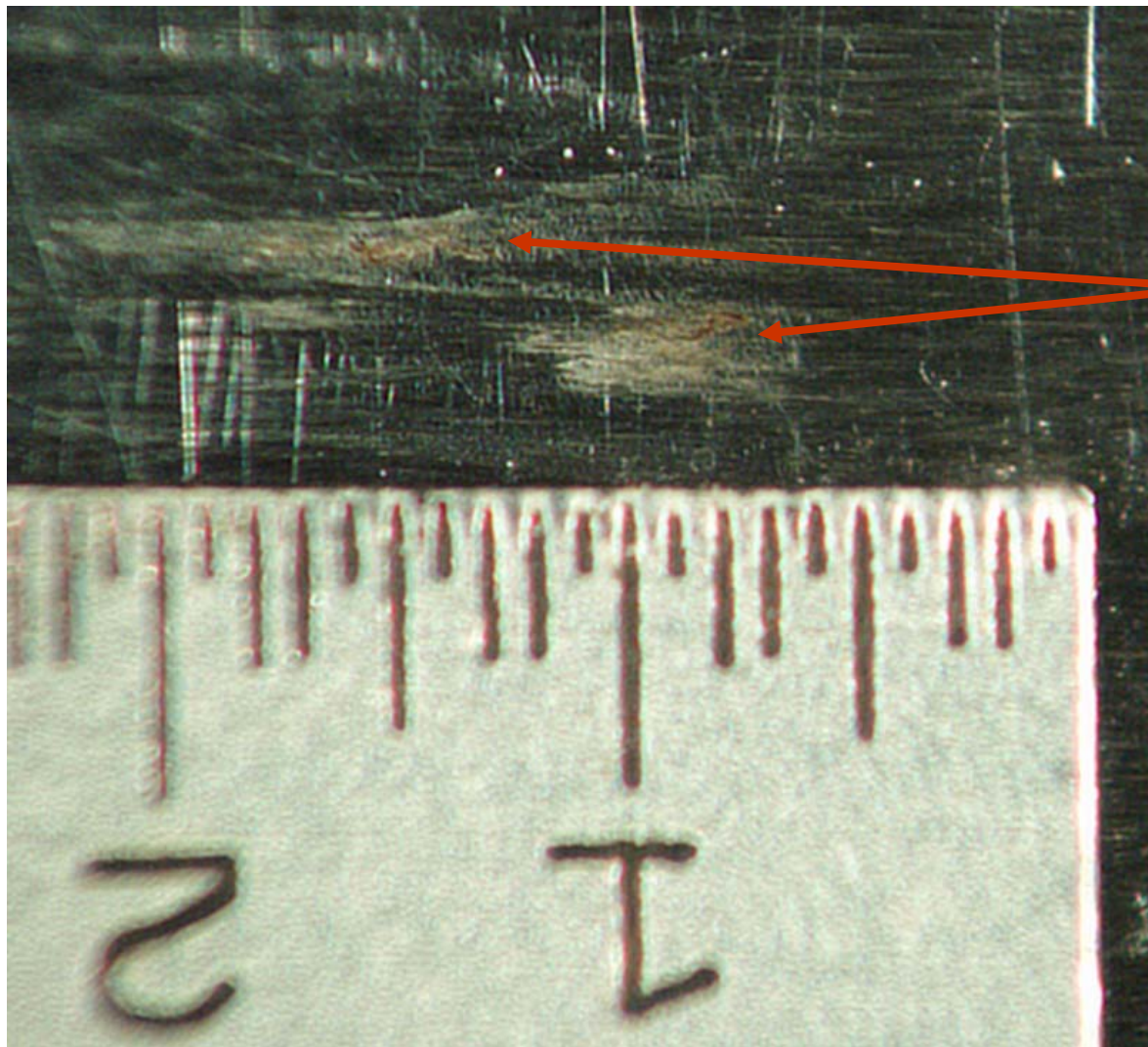

Corrosion Pits



# Defects Noted at Interface of Chrome and ESD

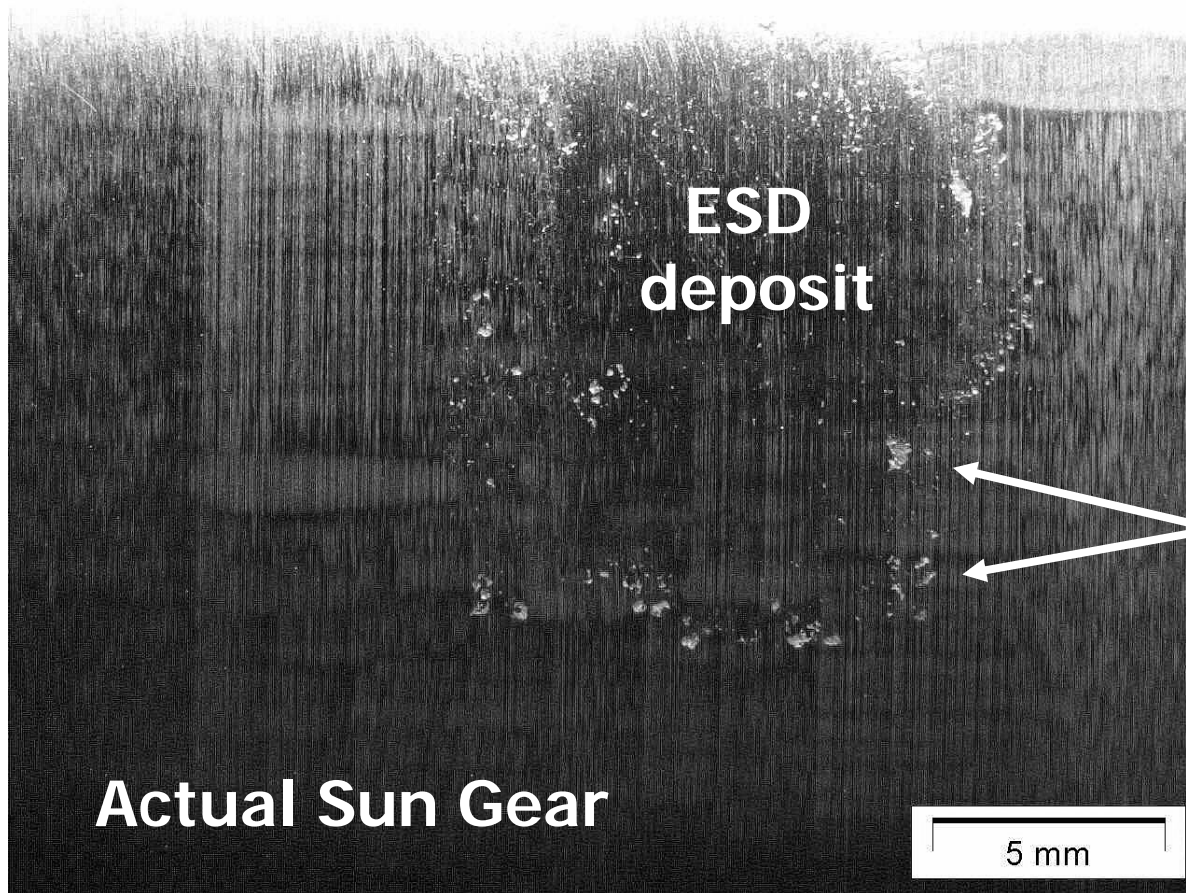

“Halo” effect around periphery of ESD deposit on chrome-plated sun gear.

Pitting at periphery of deposit



# Inconsistent Results with ESD and Chrome Plating

- Repair of defects within chrome plating led to inconsistent ESD results. A defect characterized as the “Halo Effect” was noted in many cases. This defect occurs at the interface of the deposit and the chrome plated substrate. **This problem convinced ARL and ANAD to only repair pits and wear marks through the chrome plating into the base metal.**

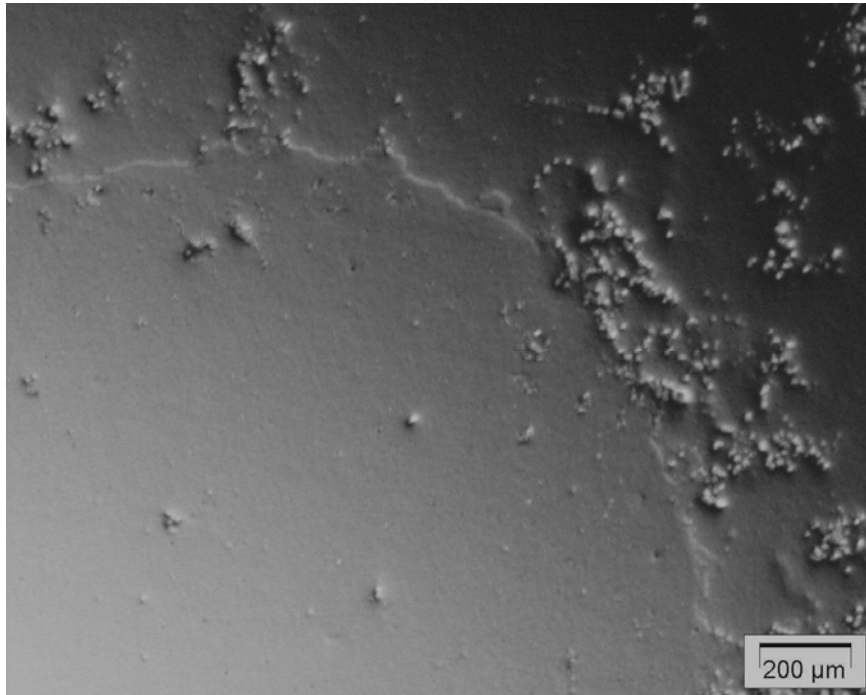

“Halo” effect around periphery of ESD deposit on chrome-plated sun gear.



# Defects Noted at Interface of Chrome and ESD Repair

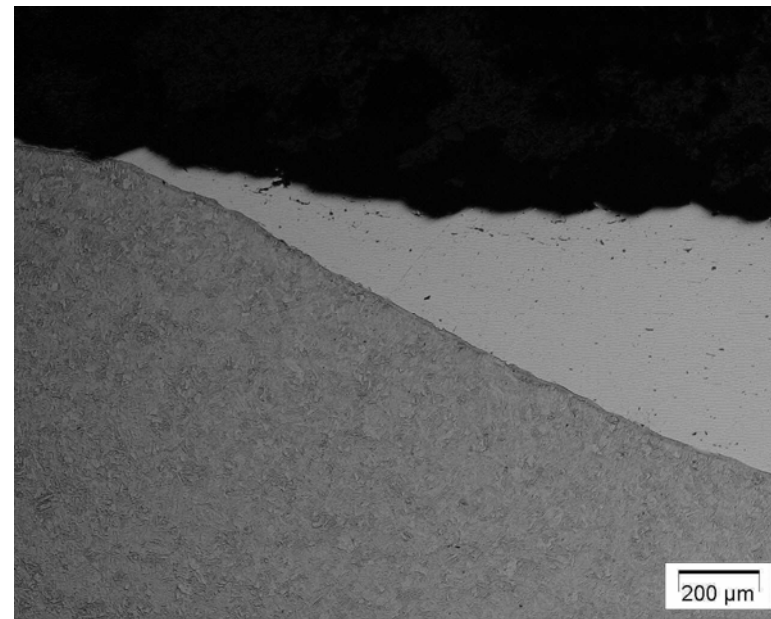
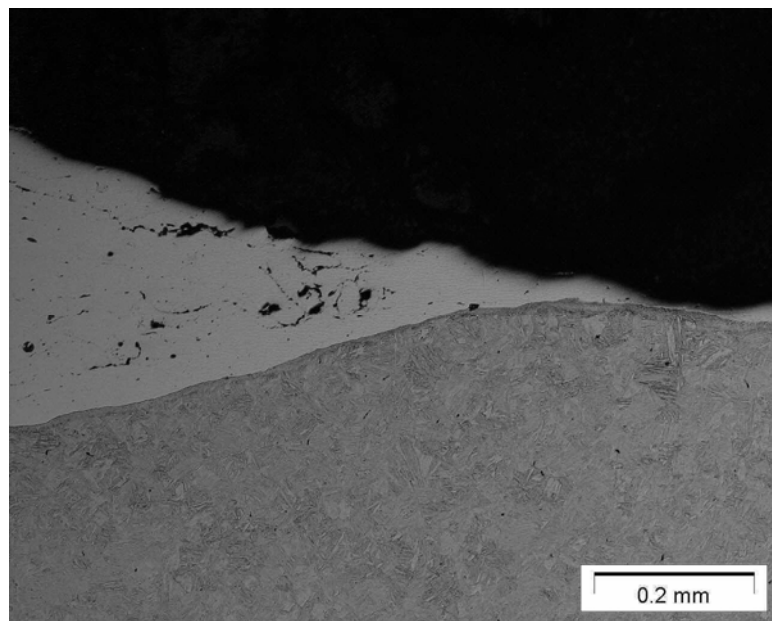

- ESD of defects in chrome-plated steel yielded mixed results – porosity noted (left), defect-free repair (right).



# SEM Micrograph of ESD Repaired Type 1b Defect after Chrome Removal

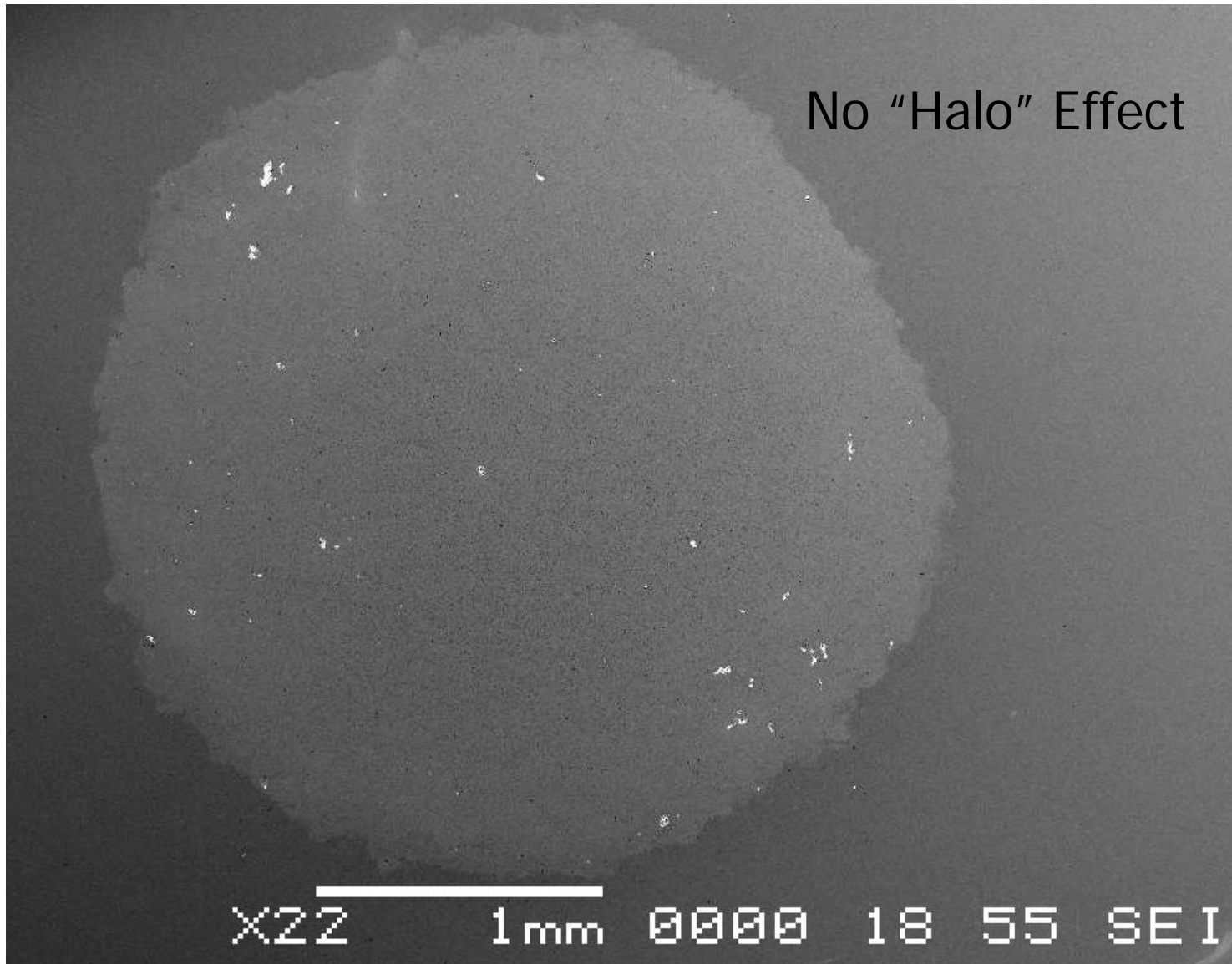



# Microhardness Through an ESD Deposit

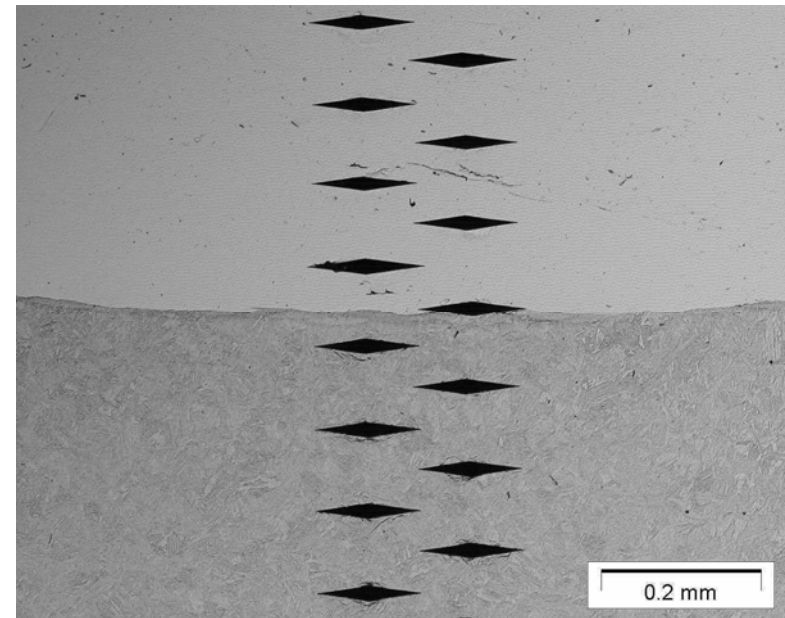
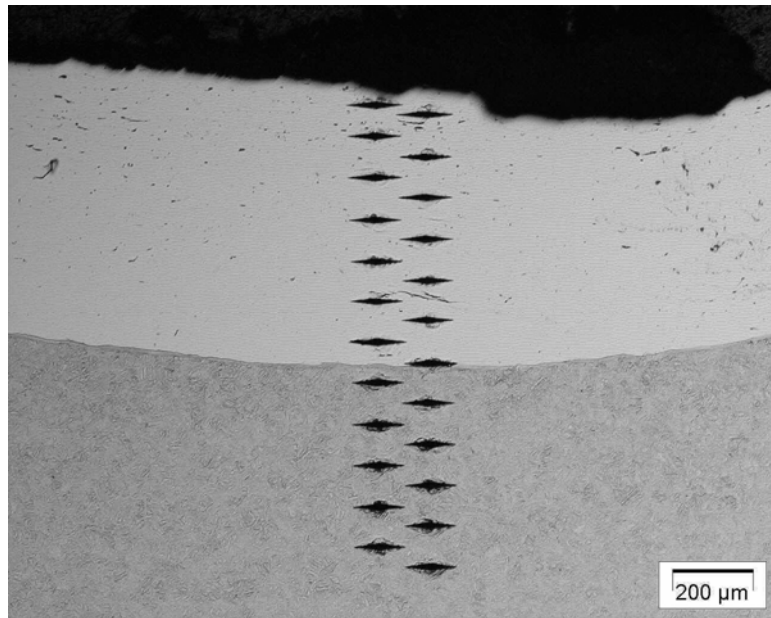

- Knoop microhardness measurements taken through ESD deposit into base material (AISI 9310). Photo on left is 50x magnification, photo on right is 100x magnification. No appreciable hardness difference between deposit and base material.



# Microhardness Through an ESD Deposit

- Knoop microhardness measurements (500gmf load, 50x objective) were taken through ESD deposits into base material (AISI 9310). Typical hardness results are as shown:

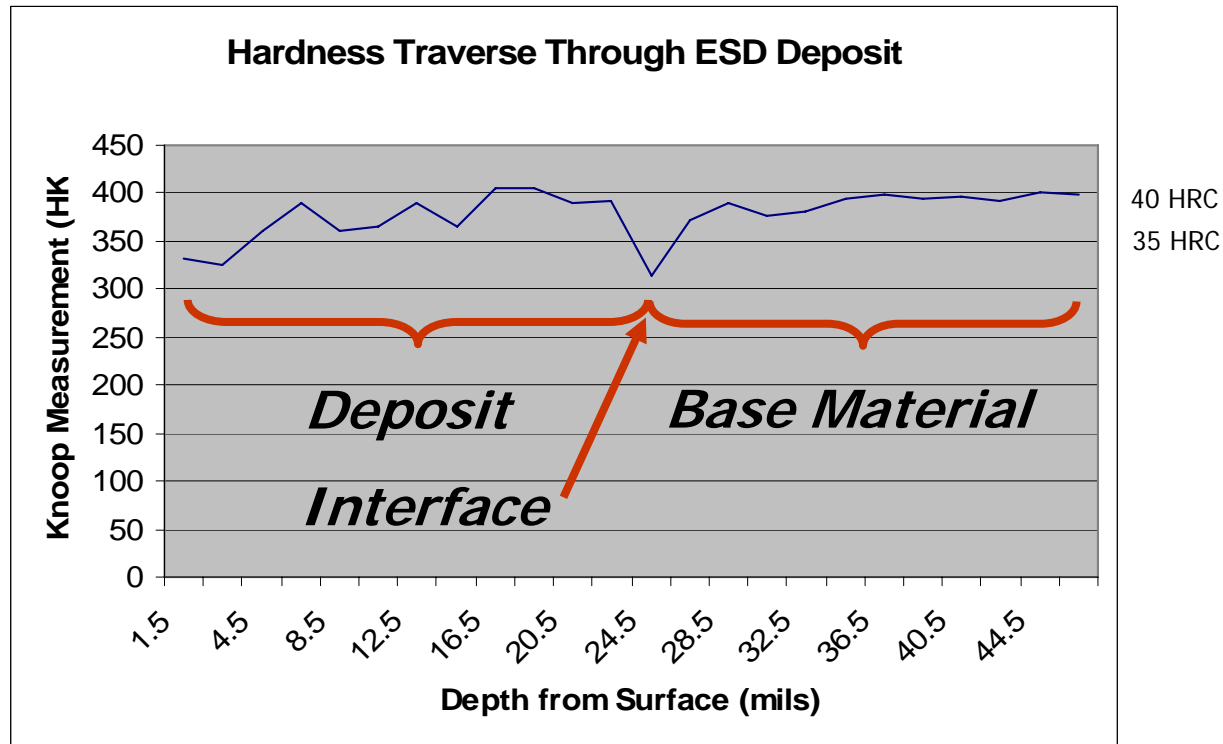



# Tensile Test Bond Bars

(ESD on 9310 Steel)





# Bond Bar Tensile Test Results

Bond Bar	Tensile Strength (psi)
1	10,453
2	9559
3	7891
4	10,136
5	10,960

Note: All were adhesive bond failures



# ESD Repair Procedure for M1 Sun Gear Shaft – DEM/VAL



- Remove Chrome Plating via grinding.
- Using a hand held grinding tool with mild abrasive bit, grind away any corrosion product until clean metal surfaces are present.
- Clean the surface to be repaired with a solvent such as ethyl alcohol and dry.
- Apply a 35 CFH flow of argon gas over the area to be repaired.
- Install a clean Inconel 718 electrode in the rotating torch.
- Perform ESD process to fill the corrosion pit to a level above the surface of the part.
- Using a hand held grinding tool and a polishing bit, polish away excess ESD material until the surface being repaired is flat and flush with the rest of the part.
- Finish polishing the surface of the part using an ultra-fine grit silicon carbide paper (>1200 grit).
- Plate with Chrome to thickness of 0.002-0.005."



# Comparison Between M1A1 Tank Cradle and Sun Gear DEM/VALs

- Cradle:
  - Material AISI 4130 chrome-plated steel
  - Electrode: Inconel 718
  - ESD Unit settings:
    - Rotating Torch
    - Pulse Rate = 580 Hz
    - Capacitance = 20  $\mu$ F
    - Voltage = 100 V
- Sun Gear:
  - Material AISI 9310 chrome-plated steel
  - Electrode: Inconel 718
  - ESD Unit settings:
    - Rotating Torch
    - Pulse Rate = 400 Hz
    - Capacitance = 30  $\mu$ F
    - Voltage = 140 V



# Benefits of ESD Repair of M1 Sun Gear Shaft



- ANAD reported 100 of these sun gear shafts per month which are inoperable as a result of corrosion pitting.
- Each of these parts costs \$2195.00 to produce.
- The estimated cost for ESD repair of the sun gear shaft is \$489.00, which is broken down to:
  - 6 Man-hours of labor per part @ \$76.50 /hr = \$459 per part
  - \$30 per part in consumables and equipment depreciation.
- Estimated savings for reclamation of M1 sun gear shaft is \$1706.00 per part.
- Total estimated savings for reclamation of M1 sun gear shaft is \$2,047,200.00 per year.



# TACOM Qualification for ESD Repair of M1 Sun Gear Shaft

- The ESD Repair Procedure has been forwarded by ARL to ANAD for TACOM Approval and Qualification Testing
- The following tests will be conducted to validate the ESD repair:
  - Fatigue testing at ARL
  - AGT 1500 (Advanced Gas Turbine) engine test stand (25 and 100 hr intervals)





# Fatigue Specimen Defect

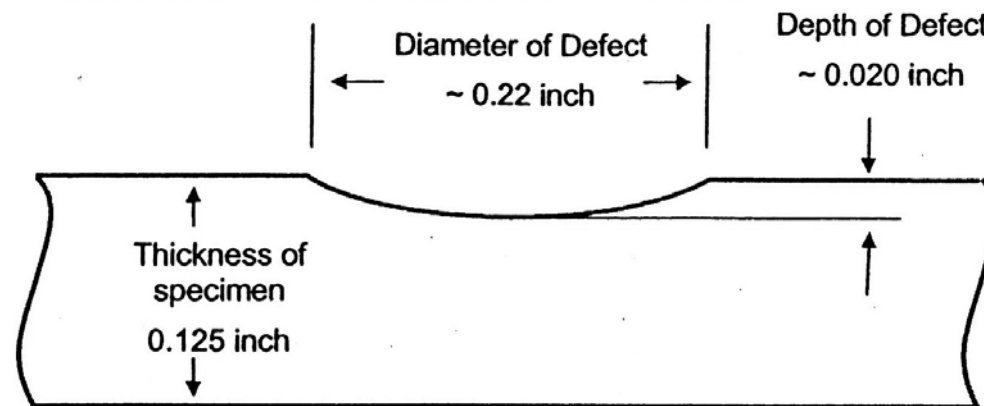

Type 1 Defect to be machined into center of gage section of fatigue specimens and ESD filled.



# Fatigue Specimen Defect

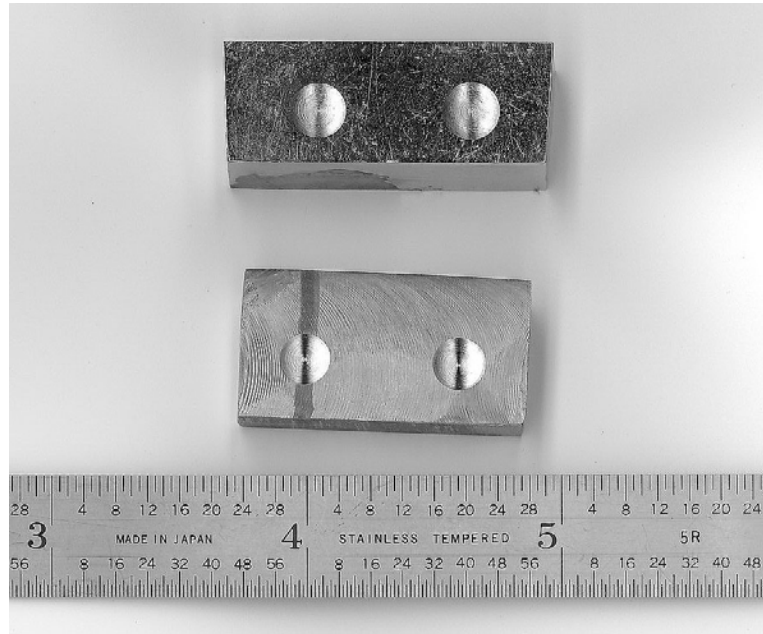

Type 1 Defects machined into chrome plated (top) and bare AISI 9310 steel samples. These defects were ESD filled as practice for fatigue test specimen deposition.



# AGT Testing



Mechanic operating an AGT-1500 Engine Test Stand. A similar test stand will be used for future testing of sun gears with ESD deposits.