

REPORT DOCUMENTATION PAGE

Form Approved
OMB No. 0704-0188

The public reporting burden for this collection of information is estimated to average 1 hour per response, including the time for reviewing instructions, searching existing data sources, gathering and maintaining the data needed, and completing and reviewing the collection of information. Send comments regarding this burden estimate or any other aspect of this collection of information, including suggestions for reducing the burden, to Department of Defense, Washington Headquarters Services, Directorate for Information Operations and Reports (0704-0188), 1215 Jefferson Davis Highway, Suite 1204, Arlington, VA 22202-4302. Respondents should be aware that notwithstanding any other provision of law, no person shall be subject to any penalty for failing to comply with a collection of information if it does not display a currently valid OMB control number.

PLEASE DO NOT RETURN YOUR FORM TO THE ABOVE ADDRESS.

1. REPORT DATE (DD-MM-YYYY) 02-05-2011		2. REPORT TYPE Master of Military Studies Research Paper		3. DATES COVERED (From - To) September 2010 - April 2011	
4. TITLE AND SUBTITLE Construction of Military Facilities in Afghanistan: Is the United States Utilizing the Best Course of Action?				5a. CONTRACT NUMBER N/A	
				5b. GRANT NUMBER N/A	
				5c. PROGRAM ELEMENT NUMBER N/A	
				5d. PROJECT NUMBER N/A	
				5e. TASK NUMBER N/A	
6. AUTHOR(S) Patrick Jors, LCDR, CEC, USN				5f. WORK UNIT NUMBER N/A	
7. PERFORMING ORGANIZATION NAME(S) AND ADDRESS(ES) USMC Command and Staff College Marine Corps University 2076 South Street Quantico, VA 22134-5068				8. PERFORMING ORGANIZATION REPORT NUMBER N/A	
9. SPONSORING/MONITORING AGENCY NAME(S) AND ADDRESS(ES) N/A				10. SPONSOR/MONITOR'S ACRONYM(S) N/A	
				11. SPONSOR/MONITOR'S REPORT NUMBER(S) N/A	
12. DISTRIBUTION/AVAILABILITY STATEMENT Unlimited					
13. SUPPLEMENTARY NOTES N/A					
14. ABSTRACT When commanders develop decisions during counterinsurgency operations their impact can potentially be great. One area where the commanders' decision is seriously affecting the battle space is construction. Since the United States spends a large portion of Afghan reconstruction funds on facilities and infrastructure, to the tune of \$17.65 billion in the last three years, the processes used to administer, manage, and execute construction projects needs to be examined. Examination of the construction process in Afghanistan needs to include how it ties into and supports the counterinsurgency "Logical Lines of Operations" (LOOs). A successful construction program directly and indirectly benefits each of the LOOs and contributes to the exit strategy. There are many ways construction impacts a battle space. Some methods are more timely, secure, or supportive of the troops' quality of life while other approaches provide better support to the LOOs and the exit strategy. A re-examination of the construction strategy can lead to improvements in Afghanistan and the eventual redeployment of U.S. forces.					
15. SUBJECT TERMS Counterinsurgency, military construction, logical lines of operations, Afghanistan, decision making, reconstruction, construction					
16. SECURITY CLASSIFICATION OF:			17. LIMITATION OF ABSTRACT UU	18. NUMBER OF PAGES 45	19a. NAME OF RESPONSIBLE PERSON Marine Corps University/Command & Staff College
a. REPORT UNCLASS	b. ABSTRACT UNCLASS	c. THIS PAGE UNCALL			19b. TELEPHONE NUMBER (include area code) (703) 784-3330 (Admin Office)

United States Marine Corps
Command and Staff College
Marine Corps University
2076 South Street
Marine Corps Combat Development Command
Quantico, Virginia 22134-5068

MASTER OF MILITARY STUDIES

TITLE:

CONSTRUCTION OF MILITARY FACILITIES IN AFGHANISTAN: IS THE UNITED STATES UTILIZING THE BEST COURSE OF ACTION?

SUBMITTED IN PARTIAL FULFILLMENT
OF THE REQUIREMENTS FOR THE DEGREE OF
MASTER OF MILITARY STUDIES

AUTHOR:

LCDR PATRICK C. JORS, CEC, USN

AY 10-11

Mentor and Oral Defense Committee Member: Dr. Mark H. Jacobsen

Approved: Mark Jacobsen

Date: 4 April (May) 2011

Oral Defense Committee Member: Dr. Robert B. Bruce

Approved: Robert B. Bruce

Date: 2 May 2011

Executive Summary

Title: Construction of Military Facilities in Afghanistan: Is the United States Utilizing the Best Course of Action?

Author: Lieutenant Commander Patrick C. Jors, Civil Engineer Corps, United States Navy

Thesis: Central Command and United States Forces - Afghanistan's operational decisions on management of military facilities construction in the Afghanistan Theater is a great example of the far reaching effects created by a course of action selected early on in a counterinsurgency operation.

Discussion: When commanders develop decisions, even on items not directly related to engaging the enemy, their impact can potentially be great. One area where the commanders' decision is seriously affecting the battle space is construction. Since the United States spends a large portion of funds allocated for Afghanistan's reconstruction on building facilities and infrastructure, to the tune of \$17.65 billion in the last three years, the processes used to administer, manage, and execute construction projects needs to be examined. Examination of the construction process in Afghanistan needs to include how it ties into and supports the counterinsurgency "Logical Lines of Operations" (LOOs). A successful construction program directly and indirectly benefits each of the LOOs, and more importantly, contributes to the exit strategy. The decision is not an easy one, especially if leaders are unfamiliar with a function, such as construction. There are many ways construction impacts a battle space. Some methods are more timely, secure, or supportive of the troops' quality of life while other approaches provide better support to the LOOs and the exit strategy. A re-examination of the construction strategy can lead to improvements in Afghanistan and the eventual redeployment of U.S. forces.

Conclusion: The methods currently utilized for administration, management, and execution of construction in Afghanistan impact success on the battlefield, tweaking some practices can result in better support to the LOOs.

DISCLAIMER

THE OPINIONS AND CONCLUSIONS EXPRESSED HEREIN ARE THOSE OF THE INDIVIDUAL STUDENT AUTHOR AND DO NOT NECESSARILY REPRESENT THE VIEWS OF EITHER THE MARINE CORPS COMMAND AND STAFF COLLEGE OR ANY OTHER GOVERNMENTAL AGENCY. REFERENCES TO THIS STUDY SHOULD INCLUDE THE FOREGOING STATEMENT.

QUOTATION FROM, ABSTRACTION FROM, OR REPRODUCTION OF ALL OR ANY PART OF THIS DOCUMENT IS PERMITTED PROVIDED PROPER ACKNOWLEDGEMENT IS MADE.

Tables

	Page
Table 1: Funding by appropriation type and amounts for OEF	23
Table 2: Funding thresholds for each appropriation	23

Photographes

	Page
Photo 1: Two-story RLBs in Afghanistan	24
Photo 2: RLBs single-story configuration	25
Photo 3: Multi-story RLBs in Afghanistan.....	25
Photo 4: Interior look at a brick wall structure	28
Photo 5: Flat roof construction in Khost.....	29

Plates

	Page
Plate 1: Sketch of curved-roof building	24
Plate 2: Sketch of curved-roof construction (single vault)	25
Plate 3: Sketch of curved-roof construction (multiple vaults).....	25
Plate 4: Sketch of flat roofed buildings.....	28
Plate 5: Sketch of a fortified compound	29
Plate 6: Sketch of a Nuristani flat roof building	30

Table of Contents

	Page
DISCLAIMER.....	i
LIST OF TABLES.....	ii
LIST OF PHOTOGRAPHS	ii
LIST OF PLATES	ii
PREFACE.....	iv
INTRODUCTION	1
BACKGROUND	2
Construction in Developing Countries.....	2
Current Construction Environment in Afghanistan	3
Construction and Counterinsurgency Operations	5
COMPARISON OF CONSTRUCTION CULTURES.....	7
History of United States Expeditionary Construction	7
Afghan Culture Relative to Construction	12
ADVANTAGES AND DISADVANTAGES OF U.S. CONSTRUCTION METHODS IN AFGHANISTAN	15
Advantages of Current Construction Methods	16
Disadvantages of Current Construction Methods	17
WAS THE DECISION FOR CONSTRUCTION METHODS SOUND?.....	20
CONCLUSION.....	21
APPENDIX A:.....	23
APPENDIX B:.....	24
APPENDIX C:.....	26
BIBLIOGRAPHY.....	31
END NOTES	34

Preface

The choice of construction as the lens to examine the difficulty counterinsurgency leaders face when selecting courses of action was developed based on: 1. The author's experience with U.S. military construction methods in Afghanistan; 2. The far reaching effects of construction on counterinsurgency battle spaces; and 3. The opportunity to compare western style construction practices used by the U.S. military with Afghan building culture. In addition, I want to thank my parents and grandparents for ensuring I received a good education, my leaders and peers in the Civil Engineer Corps for enabling the progress and enjoyment of my career, and my teachers and fellow students at the Command and Staff College for the great instruction that allowed me to write this paper. Specifically I want to thank Dr. Jacobsen for his patience in mentoring the progress of this paper and Meredith Harris, my girlfriend, for her support while I struggled through the research and writing.

Introduction

The complexity of the interconnectedness of counterinsurgency operations creates incredible difficulties for battlefield commanders when choosing operational or tactical courses of action. Short term gains realized by one operational decision may develop into long term disasters, while near term difficulties caused by another choice can result in eventual profits.¹ For example, the decision to engage enemy insurgents with lethal force can benefit a commander by reducing resistance in his battle space or, if a stray round strikes a non-combatant, the decision may increase opposition. Risk inherent in the decision making process throughout the counterinsurgency fight is big, possibly bigger than in conventional warfare. Central Command's selection of military facilities construction methods in Afghanistan is an example of how seemingly simple decisions influence a counterinsurgency operation.

Doctrinally, fighting insurgencies is the responsibility of the host nation government; third party nations – such as coalition countries composing the International Security Assistance Force (ISAF) in Afghanistan – play only a supporting role. For this reason, facilities constructed by third parties eventually become property of the host nation. Therefore, construction of usable, sustainable facilities is in the best long-term interest of both the host and third party nations. The host nation benefits from the facilities after the third party countries redeploy. The third party nations benefit from a smooth transition of the host nation into working facilities, and by a better return on their investment.

Difficulties leaders face when selecting construction methods for military facilities in wartime include cultural, economic, security, time, and quality of life implications. Depending on the type of war, leaders must weigh some implications more heavily. In conventional wars, security and time implications matter most, while culture and economic benefits probably do not factor into decisions at all. In insurgency wars, however, construction investment can seriously

contribute to the success of operations since it potentially benefits the local economy more quickly by creating jobs and industry thereby positively influencing local opinions toward the side of the counterinsurgency. In addition, cultural and economic considerations in construction techniques matter more to local populations than the security of third party forces, timeliness of construction, or the quality of life of foreign troops. While leaders certainly must consider security of their military forces, timely construction of their facilities, and their quality of life, one can argue that cultural and economic factors should weigh more on construction methods in a counterinsurgency war than a conventional war, especially in a developing country such as Afghanistan.

Currently, U.S. military forces are not spending construction funds with Afghanistan's cultural or economic interests in mind. International Security Assistance Force (ISAF) leaders are not taking advantage of key opportunities. There are advantages to the United States' choice of construction methods in Afghanistan, but the current course of action is fulfilling short-term U.S. needs, such as troop quality of life, and not the long-term needs of the Afghan people: industry, jobs, education, and governance. The United States' decisions on construction of military facilities were not operationally sound for the war in Afghanistan.

Background

Construction in Developing Countries

Governments in developing countries are typically unable to provide incentives to modernize their construction industries or promote their growth. An examination of the construction industries of developing countries by the United Nations Industrial Development Organization (UNIDO) revealed how disproportionately little consideration planners give to the construction industry.² In both developed and developing countries, however, the construction

industry plays a major role in the economy by contributing significantly to the gross domestic product, employing a large portion of the working population and interacting strongly with other sectors of the economy.³ A healthy construction industry is both a result of, and a prerequisite for, economic development.⁴ In addition, the construction industry is pivotal in infrastructure development, which can be the foundation for both economic and social progress. Construction also provides the facilities required for governance and security, which can contribute to additional capital investments in the economy, enhance social development, and empower the workforce.⁵

While construction industries in both developed and developing nations are cyclical in nature and one of the first industries to feel the effect of an economic boom or recession, the low periods of the cycle are more severe in developing nations where resources are limited.⁶ Developing countries also suffer from low standards of living, political instability, unemployment, under employment, and low levels of productivity. In addition, the fickle demand for construction, linked to political and economic instability, creates difficulties in developing strategies to stimulate growth.⁷ These trends, along with financial and other business risks, hinder the development of construction industries in developing countries under normal circumstances.

Current Construction Environment in Afghanistan

Afghanistan, as a developing country is currently facing abnormal circumstances. The recent effort of the United States to develop the capacity of the government of Afghanistan (GoA) offers a rare opportunity for military planners to provide the incentives required to develop Afghanistan's construction industry and promote its growth. Since 2005, the U.S. has allocated approximately \$56 billion for reconstruction in Afghanistan.⁸ Of the \$56 billion, the

U.S. appropriated at least \$17.65 billion for construction of infrastructure and facilities in the last three years, according to United States Central Command.⁹

According to Central Command, funding of military facilities comes from six different appropriations: Military Construction (MILCON), Operations and Maintenance (O&M), Overseas Contingency Operations (OCO), Unspecified Minor Military Construction (UMMC), Afghanistan Security Force Fund (ASFF), and Commander's Emergency Response Program (CERP). Appendix A, Table 1 provides the approximate funding for each category over the last three fiscal years. This paper focuses on construction directly supporting U.S. military forces and therefore excludes all projects using ASFF and most projects funded through CERP, as CERP and ASFF appropriations fund security and infrastructure projects in support of Afghans only such as police stations, clinics, and schools or reparations for battle damage.

The monumental task of executing over \$17 billion dollars in construction is a leadership challenge, to say the least. Managing six separate appropriations covering the requirements of military operations does not reduce the complexities either. The Government Accounting Office (GAO)¹⁰ and the Special Inspector General for Afghanistan Reconstruction (SIGAR)¹¹ assist leadership by publishing first hand reports of problems with the current construction management practices. Inspections and audits illuminate shortcomings in the planning and construction of facilities in Afghanistan.¹² The reported deficiencies raise questions concerning the selection of construction methods in Afghanistan. The most recent SIGAR report identifies contracting, program management, collaboration with Afghans, and metrics as areas to improve.¹³

In 2009, Commander United States Forces – Afghanistan, General Stanley McCrystal, delegated authority of all construction supporting U.S. military operations to the Joint Forces

Engineering Command – Afghanistan (JFEC-A). Under the JFEC are the regional engineer task forces. The Afghanistan Theater contains five regional commands: Regional Command (RC)-Central, RC-East, RC-South, RC-West, and RC-North. Each RC contains an engineer task force to plan, coordinate, manage, and execute all construction projects within the region. Each engineer task force maintains military labor, equipment, planners, and a headquarters for administration and coordination with adjacent units. More detailed information on expeditionary construction will follow in the section on United States Expeditionary Construction.

Construction and Counterinsurgency Operations

Development of construction methods to improve the areas outlined by the GAO and SIGAR and to support the counterinsurgency guidance provided by the ISAF commander, General David Petraeus,¹⁴ will arguably provide the most lasting impact and greatest probability of success. Based on Petraeus's guidance and the United States military counterinsurgency manual,¹⁵ the objective is the support of the people through development of the logical lines of operations (LOOs): civil security operations, host nation security forces, essential services, governance, and economic development.¹⁶ The LOOs provide incentives for the population to support the counterinsurgency, and a healthy construction industry is a result of, and a prerequisite for, economic, infrastructure, governance, and security development.¹⁷ Therefore, considering the dollars spent, construction is certainly one area where serious attention should be focused.

While construction is important for success in counterinsurgencies, one must realize construction is a product of local culture. The next section will focus more on how construction is directly proportional to culture, but it is worth mentioning here because of its impact on the success of a counterinsurgency. The logic is as follows: 1. Support of the people leads to

success in counterinsurgency operations; 2. Security, governance, essential services, and economic development lead to the support of the people; 3. Successful construction of sustainable infrastructure directly and indirectly provides security, governance, essential services, and economic development; 4. Knowledge of Afghan culture leads to successful construction of sustainable infrastructure. The key term in the logic is “sustainable” in number three and four. The infrastructure constructed by the occupying force, in the current case the United States, must be sustainable; otherwise, the local population will not be able to maintain it with available resources. As one of the foremost experts on Afghan history, the late Dr. Louis Dupree, stated in reference to the 1946 Helmand Valley Project: “Given the ingredients of the non-literate, peasant-tribal, inward looking society... the human problems appear as monumental as the magnificent engineering edifices left on the landscape: but without consideration of the human factor, great dams simply make great ruins.”¹⁸ While the United States is, by no means, constructing “magnificent engineering edifices,” actually far from it, what is being built will still likely make a ruin, although probably not a great one, unless it is sustainable by the Afghans after the coalition forces depart.

When one deploys to Afghanistan one receives a “culture brief” to learn about how to socialize with Afghans and not offend them. One major difference between western culture and Afghanistan is the interaction between men and women. Typically men and women do not interact socially, but if they do there are some rules. One of those rules is that a woman does not allow a man outside of her immediate family to see her without full head and body covering, or the burqa-chadari.¹⁹ One not associated with construction planning would likely not consider how such a rule could affect the decision to locate a new police station on top of a hill:

A new police station was supposed to be built on a hilltop, a strategic decision. Yet, this would have allowed all of the police and foreign visitors to see into the compounds of the local houses, where the women worked during the day. High walls surround houses in this part of Afghanistan.

The housing compound is an area where women can move freely and work without covering. If outsiders could see inside, and they were not covered, they would be dishonored. They would have to cover themselves at all times after the building was built. The women were very positive about this. What little freedom they had was being taken away. The U.S. military did not consider this when choosing the site for the facility. Eventually another site was identified that satisfied all parties. The delay caused by the local population slowed the construction of this facility by a full year.²⁰

The previous excerpt is a superb example of how understanding the local culture can impact the progress of the counterinsurgency fight.

Incorporating cultural norms into the planning process of construction projects supporting a counterinsurgency is essential since failure to do so may result in social unrest. As illustrated, if the U.S. military built the police station the local population may blame the U.S. for building it, the Afghan government for supporting it, and the local police for dishonoring their women. Instead of promoting security and essential services, the police station would create insecurity and anger. Other factors may lead to unrest: construction in sensitive areas, using unacceptable materials or techniques, hiring the wrong workforce, or corruption.²¹

Comparison of Construction Cultures

History of United States Expeditionary Construction

The United States military looks to its historical examples in times of war. In previous wars the military needed ways to quickly house people and protect materiel at far-flung bases. The building needed to be inexpensive, lightweight, and portable for shipping purposes and constructed quickly using hand tools. For millennia, tents were, and in some cases still are, the expeditionary facility of choice. During the First World War, however, the British developed a light prefabricated structure called a Nissen Hut. Although muddy, leaky, and cold, they were cheap, quickly built, and versatile. They were simple brick and tin structures used as billeting space, recreation spots, and offices for thousands of soldiers and airmen during the war. Nissen huts had concrete floors and usually a small, inefficient coke stove for warmth.²²

In early 1941, the US Military developed the Quonset Hut whose semi-cylindrical form was copied from the British hut. By the end of World War 2, the Quonset Hut was considerably different from its prototype with the major improvements being insulation and leak prevention.²³ The Quonset Hut worked well during World War 2 and the Korean War, but as board wood, plywood, and construction engineers became more available, the military shifted to the Southeast Asia (SEA) hut during Vietnam. The SEA hut was specifically developed for use in tropical areas as troop berthing, but it can be readily adapted for use in any situation or climate. The Navy Seabee training manual, *Builder 3&2: Volume 2* claims “the standard prefabrication of a SEA hut permits disassembly for movement to other locations when structures are needed rapidly. As with all disassembly of buildings, ensure it is not damaged in the process.”²⁴ The author’s experience with the construction and demolition of SEA huts (they are now called South West Asia [SWA] huts) disproves the last claim. Builders hammer together a modern SEA hut with thousands of nails, electricians wire it full of electricity and communications equipment, and utilities workers prepare it with heating and cooling. Rapid disassembly typically destroys 80% of the materials. The SWA hut, however, is currently the most constructed facility by military labor in Afghanistan today.²⁵

The idea of rapid disassembly and assembly of military facilities, however, is what leads to the newest style of expeditionary facilities utilized by United States forces in Afghanistan today. Visiting a typical logistics base in Afghanistan one will still see the older style facilities construction such as SWA huts, Quonset huts (or the larger version now called a K-span), and even a few tents, but the premier facility today is the Containerized Housing Unit (CHU) or Containerized Living Unit (CLU) or Relocate-able Building (RLB).²⁶ In Afghanistan the facilities are called RLBs, so this paper will use that term. Manufacturers fabricate the RLB with

the same dimensions as a shipping container, allowing for convenient transportation, whether by vessel, train, or semi-trailer. Appendix A provides examples of various RLB styles.

One other area of construction requiring explanation before proceeding, however, is management and administration. There are two ways the United States executes construction in support of the military: contractors and military labor. George Washington appointed the first military engineers in the Army in 1775 during the Revolutionary War, and they have participated in every war since.²⁷ The other services eventually added their own engineers. The Navy Seabees were established in 1942 to construct forward operating bases in the Pacific in support of the Navy and Marines.²⁸ The Air Force established its first engineer units in 1964 and 1965 with Prime Base Engineer Emergency Force (Prime BEEF)²⁹ and Rapid Engineer Deployable Heavy Operational Repair Squadron (RED HORSE),³⁰ respectively, in response to the demand for the ability to respond to bomb damage and disaster recovery at airfields in South Vietnam.

Contractors, of course, have also supported America's wars since the Revolution when George Washington's army relied on civilian wagon drivers.³¹ After September 11th and the Global War on Terror, high operations tempo became normal for a nation nominally at peace. Given shrinking military end strengths in the 1990's the force mix was reassessed. The shrinking military decided to emphasize the fighting "tooth" rather than the supporting "tail" in the new force mix.³² The eventual effect increased the services dependency on contractors.

Fortunately, the United States military was familiar with contract support for contingency operations. In the mid-1980s, the U.S. Army developed a policy for components to plan and contract for logistics and engineering services on worldwide contingency operations.³³ The first actual use of contract support under this Logistics Civil Augmentation Program (LOGCAP) came in 1988 to construct and maintain two petroleum pipeline systems in Southwest Asia in

support of contingency operations. In the 1990's the Navy and Air Force followed the Army's lead and entered into worldwide blanket contracts, CONCAP and AFCAP, respectively, to provide support for contingency operations.³⁴ The LOGCAP program is currently in use in Afghanistan today with the most recent contract awarded to DYNCORP in 2009.³⁵

Understanding the American expeditionary construction process requires discussing project development. When the requirement for a project is identified the requesting command submits an Operational Needs Statement (ONS) to the Joint Facilities Utilization Board (JFUB).³⁶ If the ONS is approved by the JFUB the requirement is passed to a steering committee to determine if the project will be executed by contractors or military engineers, depending on the requirement and labor availability. Military engineers typically do not possess strong design capability.³⁷ Therefore, if the project requires a design it automatically goes to contractors who possess design and build capabilities. Military engineers will typically execute horizontal work, such as minor airfield and road repairs, and basic vertical work, such as SWA huts and K-spans. Contractors will also tackle the more complex projects such as new roads and airfields, and vertical construction requiring designs.

When a project is slated for contract the requirements are passed to the contracting officer who becomes responsible for the work performed. The contracting officer then works with a military point of contact from the command submitting the ONS to develop the scope of work for the contract.³⁸ The contract is awarded, in some cases to the LOGCAP contractor, and the project is executed. Upon completion of the work, the LOGCAP contractor provides maintenance.

The last point on American expeditionary construction is planning. Planning arguably influences the product most because guidance issued at the highest levels of the military

organization sets the constraints and restraints on all construction. First, Section 169 of Title 10 of the U.S. Code³⁹ sets the funding restraints for military construction under the six appropriations listed earlier in this section. See appendix A for the funding threshold associated with each appropriation. The thresholds influence construction in two ways: they limit project funding and the timeline for receipt of funds. For example, the MILCON threshold is \$750,000, but approval of a MILCON project requires Congressional approval. Therefore, at best, a MILCON project, if justified, will receive funding on the next fiscal year's budget if it meets the deadline for all approvals up the Department of Defense chain of command. If the military requires quick completion of a project, it must cost less than \$750,000.⁴⁰ In Afghanistan, gaining approval of a project in theater leaves a commander with two options: O&M or CERP funds, depending on the type of project. Note the \$750,000 MILCON threshold is not a secret; therefore, contractors will submit bids in the \$700,000 range in order to maximize profits, which then requires more work on the government side to figure out if the costs are actually justified.

Second, the planning guidance provided by the geographical component commander further constrains builders in theater. In Afghanistan, the "Sandbook" is the published planning guidance provided by the Central Command engineers.⁴¹ The Sandbook sets limits on space allocation for offices and berthing by rank. In addition, the guidance dictates what types of facilities are authorized on a given sized base. Furthermore, the Sandbook determines a project's construction quality, and as a result, its cost, based on how long leaders expect base to operate. For example, a large base may construct a hard stand dining facility while personnel at the smallest sized camps must use tents for their meals. If leaders expect the hard stand facility to operate less than ten years builders must use temporary materials like wood or RLBs. Only if the

dining facility will operate more than ten years can engineers utilize permanent materials, such as masonry and steel.⁴²

Afghan Culture Relative to Construction

According to a Congressional Research Service report in 2010, local nationals account for 70% of the workforce in Afghanistan,⁴³ and currently ISAF construction is one of the major employers in Afghanistan due to the billions of dollars spent. Construction in Afghanistan is essentially the product of the environment and the culture. In most cases, resources are adapted to meet Afghan cultural needs and environmental conditions; Afghan cultural requirements also determine the layout of buildings and villages. These traditions are the result of a compromise between what the Afghans desire, what the environment requires, and what is available.⁴⁴ The materials used in local construction projects typically depend on the region and the type of structure.

Facilities in Afghanistan typically take the form of curved-roof construction or flat-roof construction.⁴⁵ The local structures are the result of thousands of years of accumulated knowledge passed down through the generations. Curved roof structures are found where wood is not available or where wood-boring insects are prevalent, mostly in the western part of the country and in Kandahar Province. The curved roofs provide some advantages over flat roofs such as allowing cooler air in the living area because heat rises into the vaulted roof. The layer of heat near the ceiling prevents heat from entering the building through the roof. In addition, the walls must be thicker to compensate for the heavier loads created by the curved roof. The thicker walls provide additional insulation. The curved roof structures mostly use either sun-dried brick or fired brick as the material of choice. Sun-dried bricks are not as strong as fired

bricks, but they are the most common material used because they are cheap and readily available.

“The bricks are held in place with quick-drying, highly viscous mortar.”⁴⁶

Flat roof structures are prevalent where wood is available in the central, eastern, and northern mountainous regions. There are five styles of flat roof construction. First, the mud and brick walls are found in central and eastern Afghanistan where they are constructed from pressed mud and sun-dried brick. The technique is similar to the adobe construction of the southwest United States. Second, the massive mud wall construction is found from Kabul to Kandahar in areas where there was traditionally a lack of security. The enormous walls and defensive towers, however, require constant maintenance because of erosion. Third, timber and stonewalls are normally in the remote Nuristan area and can be constructed to an acceptable height for protection yet require little or no maintenance. In addition, the timber and stone walls use “elaborate post and beam construction employing no nails.”⁴⁷ The last two types are the massive stone walls and brick and wood frame construction, but they are only found in the isolated mountainous regions of Selang and Istaf.⁴⁸

Another influence on Afghan construction is the presence of Non-Government Organizations (NGOs) that perform a multitude of service and humanitarian functions for no profit. NGOs have worked in Afghanistan since the end of World War Two and survived the Soviet occupation and Taliban government. In the early 1980's there were seventeen NGOs, by 1992 there were 160,⁴⁹ and today there are 1297 local and 313 international registered NGOs in Afghanistan.⁵⁰ NGOs received over \$14.7 billion dollars from donor nations between 2002 and 2008; the United States led with \$5 billion.⁵¹

The problem with the NGOs is a catch twenty-two. Afghanistan needs the NGOs to provide essential services, but they come at a high price. First, the NGOs hire the qualified

workers away from the Afghan government because the NGOs pay better due to their funding sources. Then the Afghan government must hire the NGO to provide certain services, at a higher cost, because the government does not possess the ability to do it.⁵² If the Kabul government could provide better pay and management, it could provide the services for at least the same cost, in addition to building the credibility of being a service provider. In effect, the NGOs contribute to the de-legitimization of the government.

In addition, the NGOs strain their relationship with the Afghan government when they openly criticize them, promoting further doubt as to the government's legitimacy.⁵³ Because of the past poor relationship the government passed a law in 2005 requiring NGOs to register with the Ministry of Economy. The law requires NGOs to obtain permission from the Minister of the Economy prior to "participation in construction projects and contracts."⁵⁴ This law made it very hard for NGOs to obtain legal permission to build in Afghanistan but provided much better government oversight on construction projects and contracts. More importantly, the law differentiated between NGO and for profit companies, stripping the NGO title from private businesses seeking tax exemption, and increasing the credibility and impartiality of actual NGOs. Potentially the law, which by itself shows progress of governance, can rehabilitate the relationship between the NGOs and the government and further the ability of Afghanistan to provide its own services and develop legitimacy.⁵⁵

In addition to NGOs Provincial Reconstruction Teams (PRTs) contribute to the construction environment in Afghanistan. The PRTs were created by the Bonn Donors' Conference Agreement in 2001.⁵⁶ PRTs are used to promote the Afghan government's reconstruction by providing infrastructure and services to communities. A PRT is typically around 100 people composed of coalition military, diplomatic, and reconstruction experts.

Coalition governments responsible for the PRT provide the funding. USAID and the State Department fund American-led PRTs. Compared to the NGOs, the PRTs' focus is more short term, to win "hearts and minds" and reduce violent incidents. The approach, however, does not always account for long term effects of the PRTs' projects with regard to sustainability or community buy in often leading to lack of support for a facility after completion. In other words, the U.S. is doing well influencing the hearts of the Afghans – gaining their respect for the reconstruction efforts – but many Afghans do not believe the U.S. will stay long enough to change their lives.

Advantages and Disadvantages of U.S. Construction Methods in Afghanistan

Several considerations allow us to evaluate success: timeliness, cost impact on LOOs, quality, security, and support to the war fighters. Timeliness needs consideration because of the urgency placed on wartime operations and the impatience of the Afghans and the American public towards the mission in Afghanistan. Funding is not an issue in the Afghan Theater, as General Petraeus stated in his counterinsurgency guidance to NATO forces "money is ammunition"⁵⁷ and "how we spend is often more important than how much we spend."⁵⁸ Along similar lines, one might ask whether the right quality standards are being set for construction in Afghanistan and are they helping or hurting the mission – are they winning hearts and convincing minds? The security implications of the construction project decisions result in lives saved or lost on the battlefield, are they supporting the war fighters?

Advantages of Current Construction Methods

As far as timeliness, the U.S. is benefitting from the current construction methods supporting military operations. First, funds are plentiful and readily available as long as the project can be executed for less than \$750,000, which is still a substantial sum of money in

Afghanistan. One can surmise that much can be accomplished in Afghanistan if a project is properly planned using local labor and resources. Even without local labor, contractors provide plenty of support for construction of facilities. In addition to contractors, NGOs and PRTs also contribute to the execution of construction projects, further enhancing the ability of the United States to quickly accomplish projects supporting operations in Afghanistan. Beyond labor, the plethora of construction equipment sent to Afghanistan to support the engineer task forces improves project schedules compared to what the case would be if the armed forces relied on locally rented or contracted equipment.

Quality of construction is definitely a feature western engineers can introduce to Afghanistan, since buildings in developing countries should be built according to specifications and codes. The United States maintains trained contracting officer representatives (COR) to ensure quality control, and organizations such as the GAO and SIGAR to prevent corruption, waste, fraud, and abuse. While there are some complaints about construction quality in Afghanistan⁵⁹ one can argue that due to the enormity of the reconstruction⁶⁰ there will be some items slipping through the COR's oversight. DOD construction contracts awarded follow guidelines in the *Federal Acquisition Regulation* that spell out requirements for quality control,⁶¹ quality assurance,⁶² and safety.⁶³ Furthermore, U.S. planners possess knowledge on guide specifications and building codes that will ensure the safe construction of facilities.

A major concern for the construction of facilities supporting U.S. forces is security. The current method of execution by either military labor or vetted contractors established on coalition bases is certainly an advantage for security purposes. Since construction in direct support of U.S. military operations is more often than not limited to the bases where American troops eat, sleep, work, and live, concern for security cannot be high enough. In addition to labor, supply

sources are a security concern also. One item that is nearly always supplied locally is gravel. Gravel typically arrives in a dump truck, potentially a good delivery method for an improvised explosive device, as occurred in 2007 in Ramadi, Iraq.⁶⁴ The military and contractors essentially mitigate risk when they arrange for supplies flown in from the United States or Europe, but the costs are colossal.

One area where the current construction practices do not show much direct benefit is the support of the five counterinsurgency LOOs: civil security operations, host nation security forces, essential services, governance, and economic development. One may argue that construction of facilities supporting ISAF units indirectly benefits civil security operations, Afghan security forces, and governance. However, the benefits are merely short term, once the ISAF units redeploy their facilities no longer support security or governance. There are some benefits to the economy through Afghan labor hired by contractors, but due to the types of facilities constructed, the Afghans are not developing useful long-term labor skills.

Support of the war fighter is the primary function of facilities constructed by the U.S. on coalition bases in Afghanistan. A major benefit of the current construction methods in Afghanistan is its familiarity, which leads to timely construction. The military engineers are very proficient at building SWA huts and K-spans, and as a result they can construct them rather quickly. Constructing unfamiliar Afghan style structures would require a learning curve that would hinder operations. In addition, since security and safety of the troops is most important, the current requirement for construction of facilities to meet international building codes is extremely beneficial. Finally, the use of military and vetted contractor labor presents a low threat and mitigates risk of terrorism on coalition bases.

Disadvantages of Current Construction Methods

Current construction practices still proceed slowly, most notably projects over the MILCON threshold and because of the inefficient supply chain in Afghanistan. Realistically, to build a quality facility in Afghanistan one must exceed the MILCON threshold. Currently, military engineers are constructing oversized SWA huts for slightly less than \$600,000, which does not leave much room for quality improvements before reaching the MILCON limit. Furthermore, the MILCON threshold restricts the planners' ability to meet short-term facility requirements while at the same time developing Afghanistan's economy and supply chain by using local materials for construction. In order to develop local material sources such as masonry and concrete, initial construction costs will today exceed MILCON. Only eventually will costs decrease as local sources are established. The under developed construction materials business in Afghanistan also creates delays in construction completion times. Since most construction supplies are not now locally available, military engineers and contractors must rely on resources from Europe and America, which often take weeks, or even months, to arrive in theater and they cost more.

Since both the MILCON threshold and limited local supplies restrict what can be constructed, quality suffers. The service member is essentially stuck with wooden SWA huts, metal K-spans, RLBs, or tents for their operational facilities. In Afghanistan, because of the environment, wood, metal, and tent fabric do not last long. Wood warps from the extremely hot and dry weather and termites lay waste to SWA huts once treatments degrade from the elements. SWA huts also pose a high fire safety risk. Metal K-spans are better than SWA huts, but due to the higher material costs their size is very restricted, which limits their use. RLBs provide a quality facility but even less space than a K-span since they are the standard container size of

eight by eight by twenty or 160 square feet. Tents do not provide adequate shelter from the dust, cold, and heat and do not last beyond a short period.

The current facilities by themselves do not provide security against indirect fire such as mortars or rockets or against improvised explosive devices. Expensive concrete walls, sandbags, and HESCO barriers provide protection for the SWA huts, K-spans, and tents. The reinforcement substantially increases costs, but security costs do not count against the MILCON threshold. While reinforcement protects against horizontal fire, indirect fire from rockets and mortars are still deadly threats as they often avoid concrete walls and HESCO barriers.

Probably the biggest disadvantage of the current construction process concerns its support of the counterinsurgency LOOs. First, the United States is occupying bases once belonging to Afghanistan and one day the Afghan military will use them again. Therefore, building facilities the Afghan military forces can move into, utilize, and maintain after the war is the most beneficial course of action. However, the temporary facilities the U.S. military is constructing will not last long enough for the Afghan military to use. Even if the U.S. did construct permanent facilities, the Afghans face near impossible maintenance requirements as the construction used materials from the United States and Europe instead of developing local supplies. One should note the millions of dollars spent on RLBs are going to the Italian and Chinese companies supplying the RLB containers.⁶⁵ Another disappointment about the construction of military bases in Afghanistan is the lack of buy in or partnership with the Afghan government on how they want their bases developed so they can use them when we leave. Instead, the United States is spending money building facilities for its own forces and then spends more money to construct ANSF structures on land adjacent to coalition bases. One bird is being killed with two stones in this case.

One can argue that setting conditions for a stable Afghanistan leading to redeployment of U.S. forces best supports the war fighter. The current construction strategy is not supporting long-term establishment of the counterinsurgency LOOs, as shown in the previous paragraph. The substantial OEF construction funding can positively influence, either directly or indirectly, the LOOs, which, according to war fighting manuals, would lead us to an exit strategy.

Was the Decision for Construction Execution Methods Sound?

Was the decision to use the historically standard expeditionary construction methods in support of military operations in Afghanistan sound? Applying the logic a successful COIN operation requires, one can begin to see both problems and genuine success. To refresh, the logic follows: 1. Support of the people leads to success in counterinsurgency operations; 2. Security, governance, essential services, and economic development lead to the support of the people; 3. Successful construction of sustainable infrastructure directly and indirectly provides security, governance, essential services, and economic development; 4. Knowledge of Afghan culture leads to successful construction of sustainable infrastructure. Again, the key term in the logic is "sustainable" in number three and four.

The U.S.'s utilization of western construction labor, materials, and styles is not developing sustainable infrastructure on military bases in Afghanistan. Since the United States is not collaborating with the Afghan government in constructing military facilities, there is no buy in, no genuine partnership, and no net contribution to Afghan development or infrastructure. Since there is no buy in, the U.S. is building facilities that will most likely not be sustainable by the Afghan government once the U.S. leaves. As a result, the bases will need rebuilding or abandonment. Rebuilding will be difficult, as development of local suppliers did not happen during construction. Since the infrastructure is not sustainable, it does not support long term

functioning of security, governance, essential services, or economic development in Afghanistan, and the coalition forces are no closer to the exit from Afghanistan.

What can remedy the faults of the current construction strategy in Afghanistan? The recommendations of SIGAR and the GAO can lead to improvements in the use of construction dollars, specifically development of a better relationship with Afghan labor and suppliers. There are other potential improvements capable of enhancing funds spent on construction. Commanders need the ability to exceed the MILCON threshold if they can justify additional costs in order to develop local sources of construction materials and labor to support development of the LOOs. As mentioned by the GAO and SIGAR, partnerships with the Afghan government should be further developed in order to better plan for their future infrastructure as far as military installations. Lastly, ISAF should develop more Afghan contractors despite the fact that they will not be able to comply immediately with all of the requirements in the *Federal Acquisition Regulation*.

Conclusion

When commanders develop decisions, even on items not directly related to engaging the enemy, their impact can potentially be great. One area where the commanders' decision is seriously affecting the battle space and long-term outcomes is construction. Since the United States spends the majority of funds allocated for Afghanistan's reconstruction on building facilities and infrastructure, to the tune of \$17 billion in the last three years, the processes used to administer, manage, and execute construction projects need to be examined. Examination of the construction process in Afghanistan needs to include how it ties into and supports the counterinsurgency "Logical Lines of Operations." A successful construction program directly and indirectly benefits each of the LOOs, and more importantly, contributes to the exit strategy.

The decision is not an easy one, especially if leaders are unfamiliar with a function, such as construction. There are many ways construction impacts a battle space. Some methods are more timely, secure, or supportive of the troops' quality of life while other approaches provide better support to the LOOs and the exit strategy. A re-examination of the construction strategy can lead to improvements in Afghanistan and the eventual redeployment of U.S. forces.

APPENDIX A

MILITARY FUNDING APPROPRIATIONS AND LIMITATION

Table 1: Funding by appropriation type and amounts for OEF.⁶⁶

Fund Type	FY09	FY10	FY11	TOTAL
OCO, O&M, and UMMC	\$1.40	\$1.75	\$1.05	\$4.20
MILCON	\$1.00	\$1.40	\$1.60	\$4.00
CERP	\$0.55	\$1.00	\$1.20	\$2.75
ASFF	\$1.10	\$2.70	\$2.90	\$6.70
TOTAL	\$4.05	\$6.85	\$6.75	\$17.65

Amounts in billions.

Table 2: Funding thresholds for each appropriation.⁶⁷

Fund Type	Maximum	Approving Authority
OCO		Secretary of Defense
O&M	\$750	Task Force Commander – JFUB
O&M to correct life threatening conditions	\$1,500	Task Force Commander – JFUB
UMMC	\$2,000	Service Secretary
UMMC to correct life threatening conditions	\$3,000	Service Secretary
MILCON		Congress
CERP	\$500	Local Commander
ASFF		Congress

Amounts in thousands.

APPENDIX B

TYPICAL RLB CONFIGURATIONS

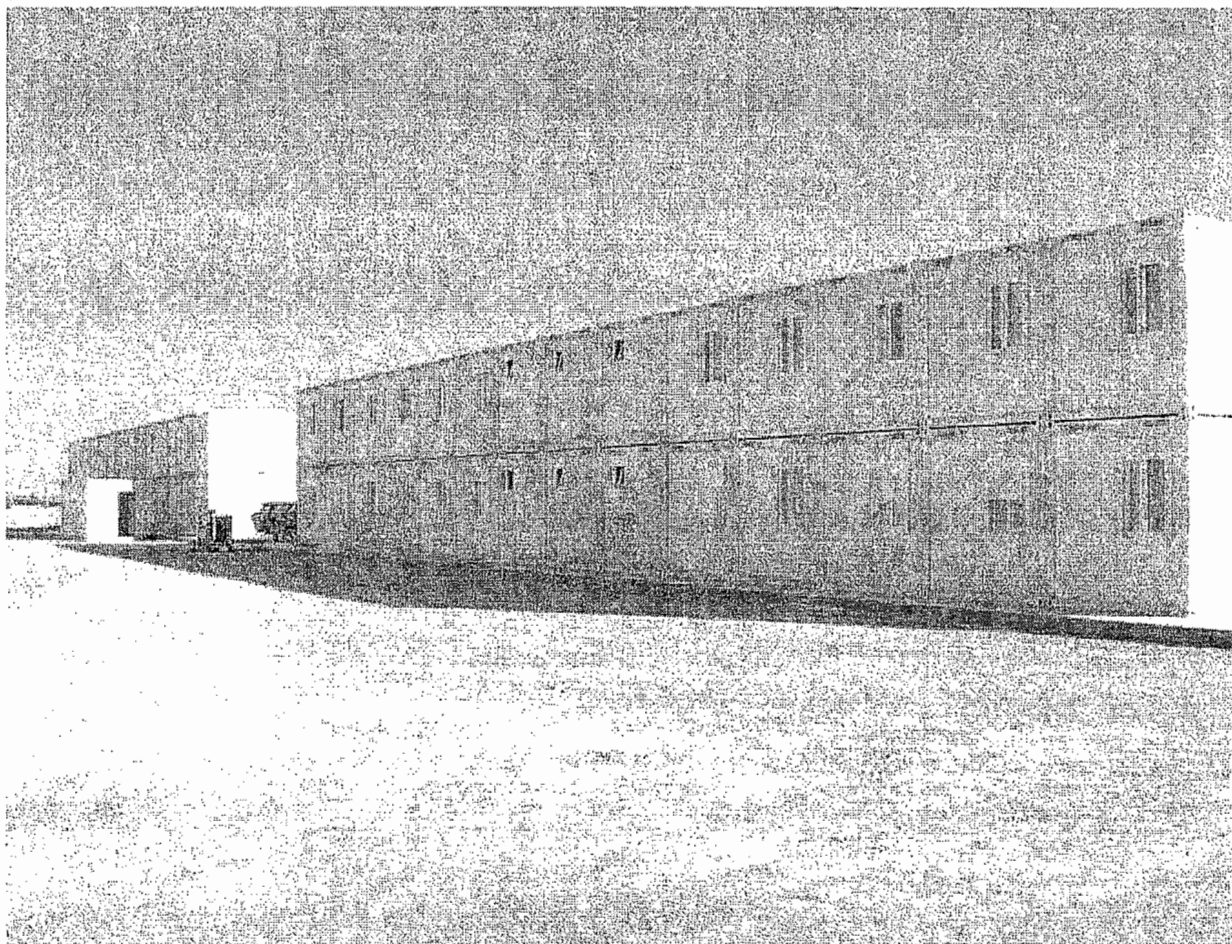

Photo 1: Two-story RLBs in Afghanistan⁶⁸

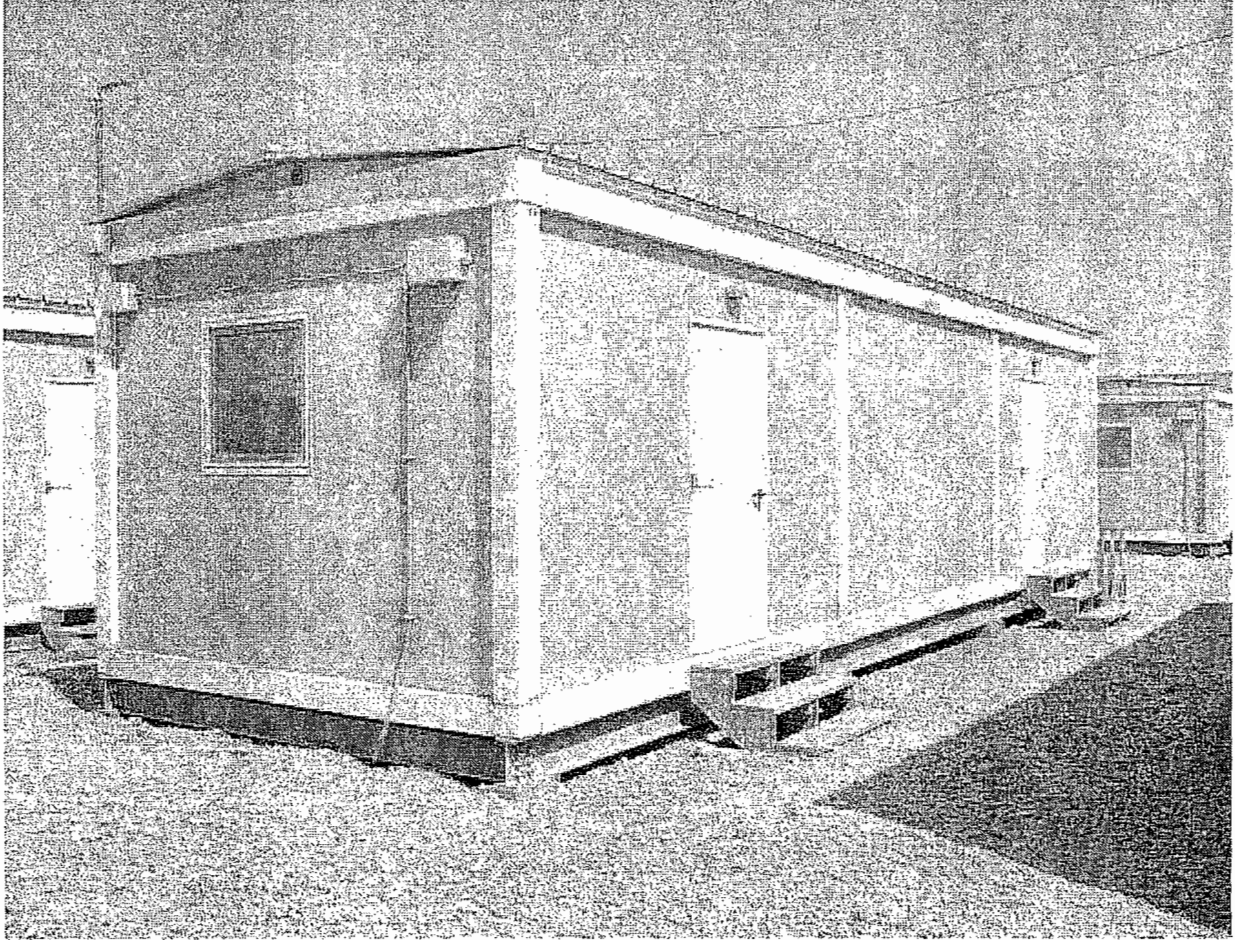

Photo 2: RLBs single story configuration.⁶⁹

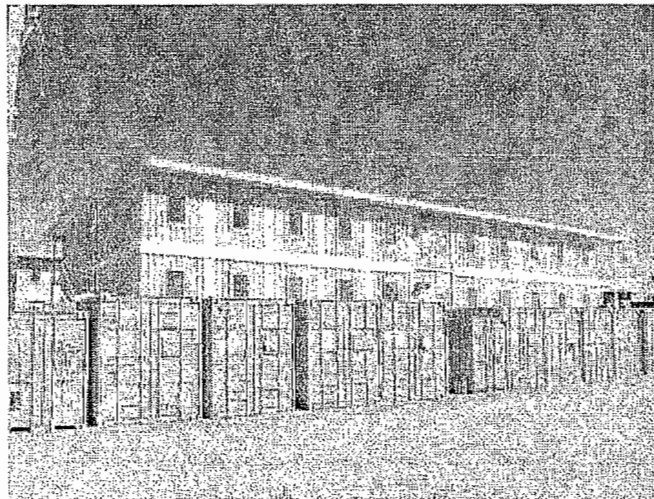

Photo 3: Multi-story RLBs.⁷⁰

APPENDIX C

SEDENTARY DWELLING SKETCHES

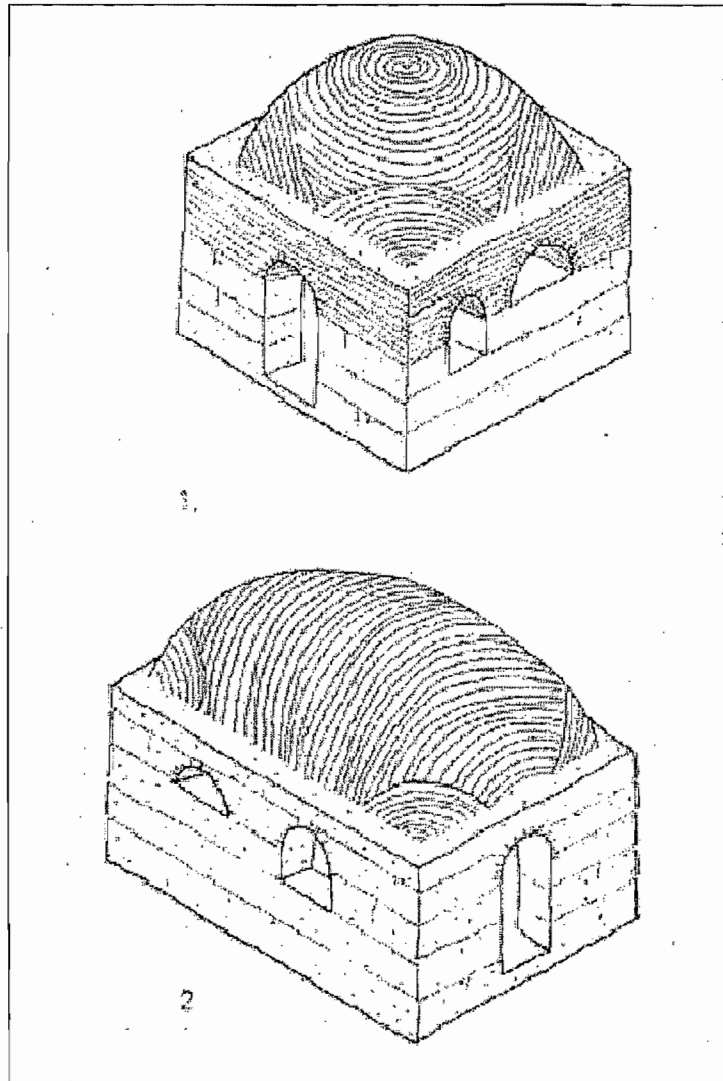

Plate 1: Sketch of curved roof building.⁷¹

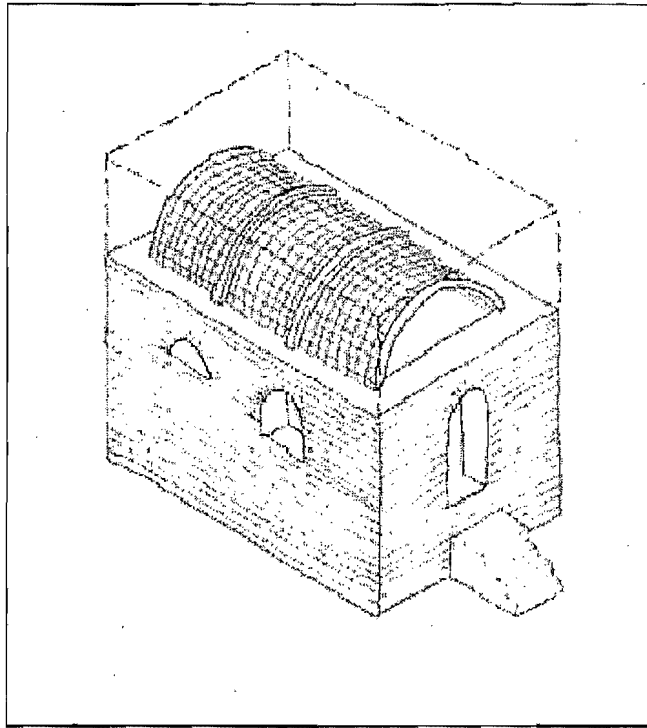

Plate 2: Sketch of curved-roof construction (single vault).⁷²

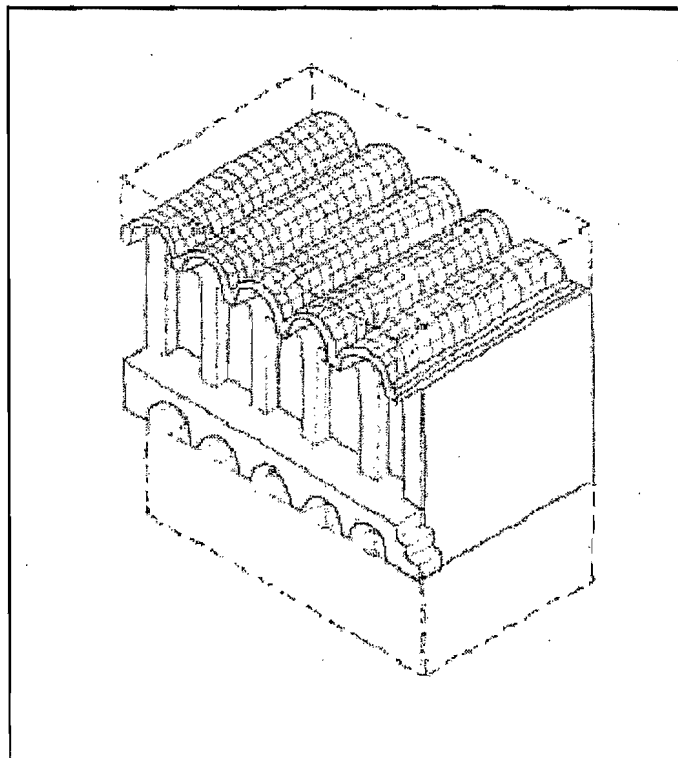

Plate 3: Sketch of curved-roof construction (multiple vaults).⁷³

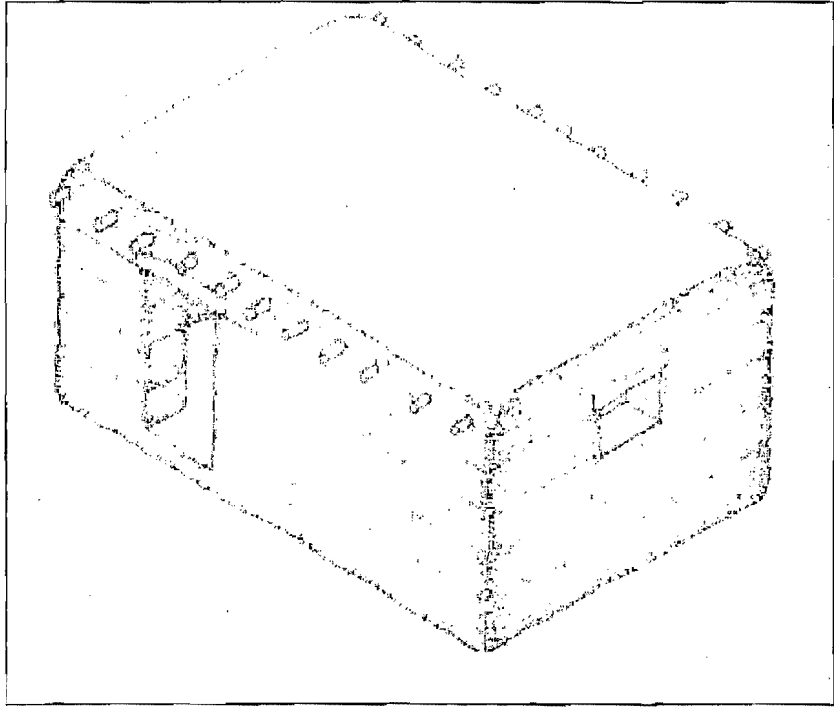

Plate 4: Sketch of flat roof buildings.⁷⁴

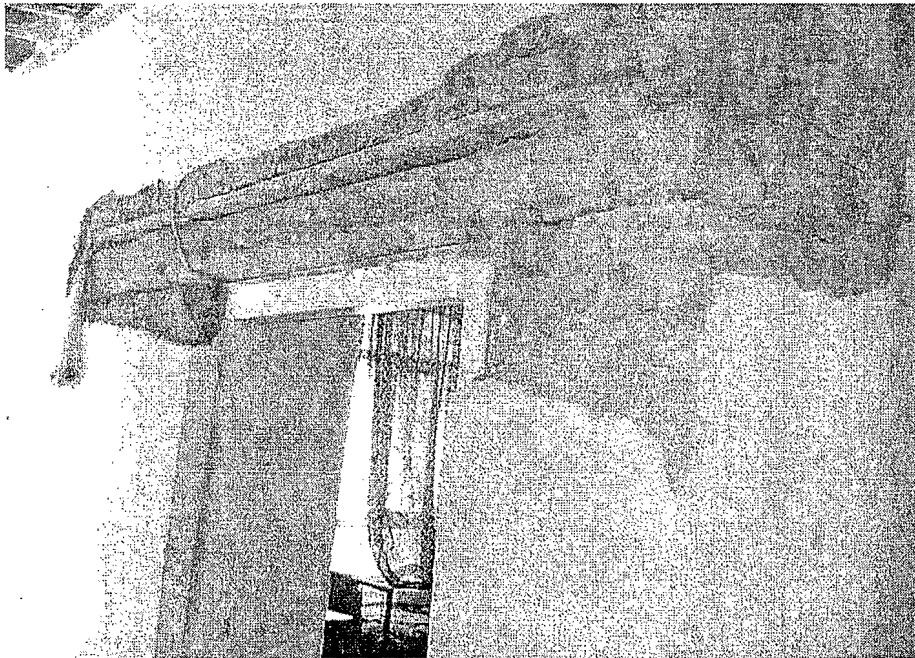

Photo 4: Interior look at brick wall structure.⁷⁵

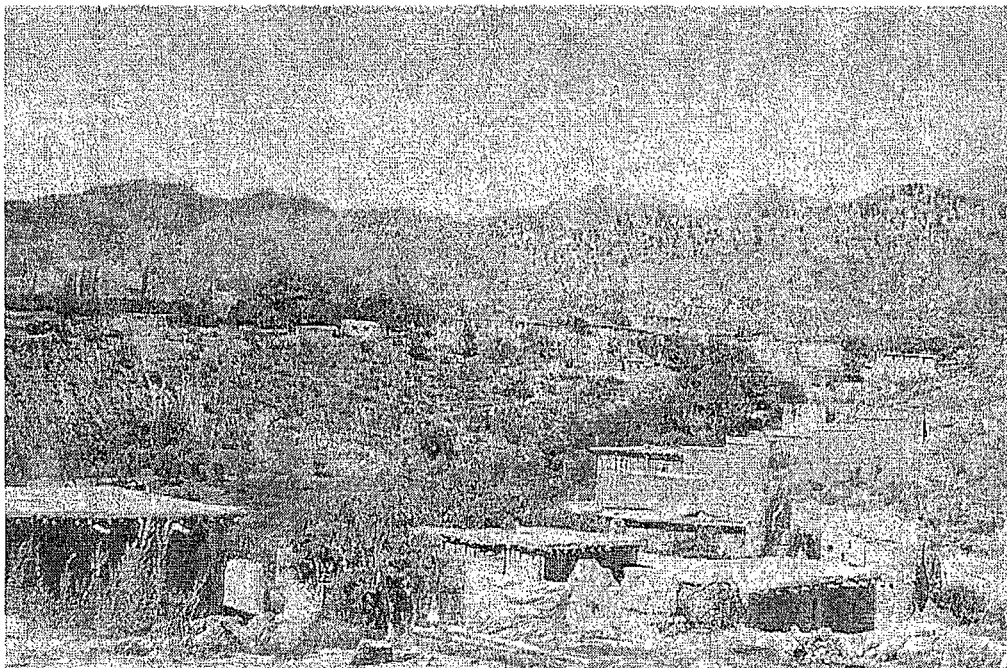

Photo 5: Flat roof construction in Khost.⁷⁶

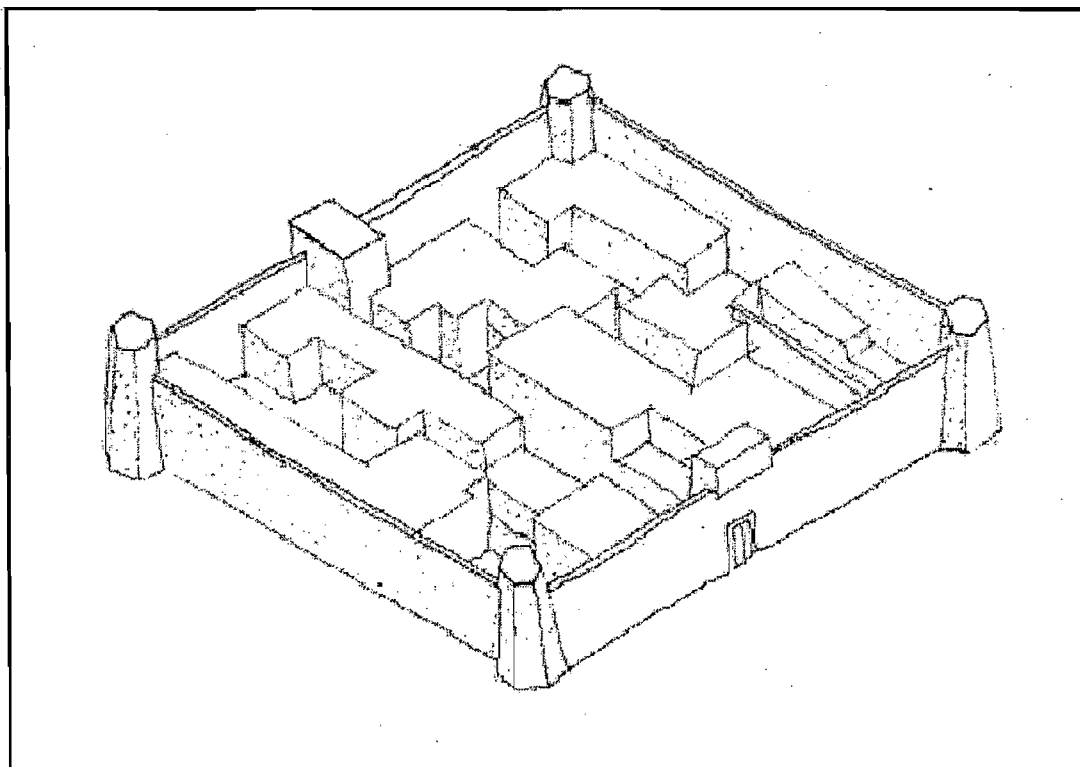

Plate 5: Sketch of a fortified compound.⁷⁷

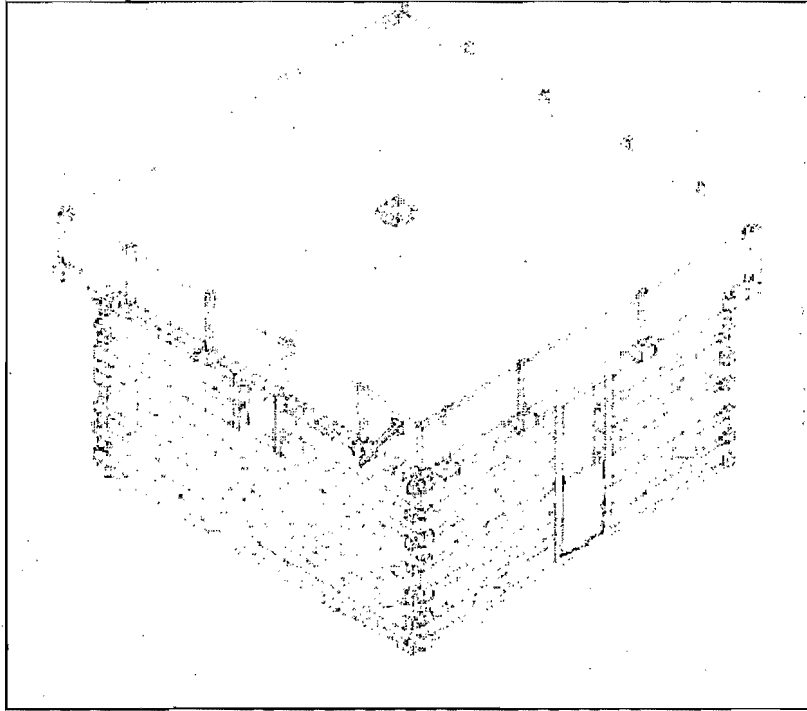

Plate 6: Sketch of a Nuristani flat roof building.⁷⁸

Bibliography

(SIGAR), Special Inspector General for Afghanistan Reconstruction. *Report to the United States Congress. Quarterly*, Arlington: SIGAR, 2010.

Afghanistan-Culture.com. *Burqa-Chadari, Afghan women head and body covering cloth*.
<http://www.afghanistan-culture.com/burqa-chadari.html> (accessed January 16, 2011).

Air Force Civil Engineer Support Agency. *Factsheets: RED HORSE history*.
<http://www.afcesa.af.mil/library/factsheets/factsheet.asp?id=8760> (accessed January 15, 2011).

—. *Factsheets: UNITED STATES AIR FORCE PRIME BEEF UNITS*.
<http://www.afcesa.af.mil/library/factsheets/factsheet.asp?id=16797> (accessed January 15, 2011).

Borton, Nigel Nicholds and John. "The Changing Role of NGOs in the Provision of Relief and Rehabilitation Assistance: Case Study." *Overseas Development Institute*. 1994.
<http://www.odi.org.uk/resources/details.asp?id=2561&title=changing-role-ngos-provision-relief-rehabilitation-assistance-1-afghanistan-pakistan> (accessed January 20, 2011).

Clough, Richard H. and Glenn A. Sears. *Construction Contracting*. New York: John Wiley and Sons, 1994.

Corimec Italiana S.p.A., member of the Casti Group. *CORIMEC: Mission*. 2011.
http://www.corimec.com/c_e-mission.htm (accessed March 5, 2011).

Dupree, Louis. *Afghanistan*. Oxford: Oxford University Press, 1973.

Gussman, Neil. *Armynow.com*. May 18, 2009. <http://armynow.blogspot.com/2009/05/home-sweet-trailer-home.html> (accessed February 27, 2011).

Headquarters United States Central Command. *Construction and Base Camp Development in the US CENTCOM Area of Responsibility*. MacDill Air Force Base: Headquarters United States Central Command, 2009.

Keithly, Ferris and. "Outsourcing the Sinews of War: Contractor Logistics." *Military Review*, 2001: 70-73.

Made-in-China.com. *Modular Building in Afghanistan - China Office Container, Accommodation Container, Living Container*. 2011. <http://cnstarhouse.en.made-in-china.com/product/jqCxvXKoygVu/China-Modular-Building-in-Afghanistan.html> (accessed February 27, 2011).

Malan, Legena M. "Sustainable Construction in Afghanistan." Monterey: Naval Post Graduate School, September 2010.

Milne, Gustav. *The Port of Roman London*. London: B.T. Batsford, 1985.

Moavenzadeh, F. "The Construction Industry and Economic Growth." *Asian National Development*, June/July 1984: 56-60.

Naval Education and Training Command. *Builder 3&2, Volume 2*. Pesacola: Naval Education and Training Professional Development and Technology Center, 1994.

Naval History and Heritage Command. *Seabee History: World War II*.
<http://www.history.navy.mil/faqs/faq67-3.htm> (accessed January 15, 2011).

—. *USN ID tags*. <http://www.history.navy.mil/faqs/faq75-1.htm> (accessed January 14, 2011).

Relyant. *Relocatable Buildings (RLBs)*. 2011.
<http://www.gorelyant.com/relocatablebuildingsproject> (accessed February 27, 2011).

Schwartz, Moshe. "Department of Defense Contractors in Iraq and Afghanistan: Background and Analysis." *Congressional Research Service*. July 2, 2010.
<http://www.fas.org/sgp/crs/natsec/R40764.pdf> (accessed January 18, 2011).

Seabee Museum. *Quonset Huts. . . Developed in Rhode Island*.
http://www.seabeesmuseum.com/Quonset_Huts.html (accessed January 14, 2011).

Szabo, Albert, Thomas J. Barfield, and Edward F. Sekler. *Afghanistan: An Atlas of Indigenous Domestic Architecture*. Austin: University of Texas Press, 1991.

Tyron, Joseph D. "Theater Construction Management System: Time to Raise the Standards." *Engineer*, 2008: 51-54.

U.S. Army Corps of Engineers. *U.S. Army Corps of Engineers: A Brief History*. November 6, 2007. <http://www.usace.army.mil/History/Documents/Brief/index.html> (accessed January 15, 2011).

U.S. Central Command Engineers. "Society of American Military Engineers: Tampa Bay, FL Post." *Society of American Military Engineers*. January 16, 2011.
<http://posts.same.org/tbaypost/Past%20meetings%20presentations/CENTCOM%20Eng%20Brief%20-%20AUG10.pdf> (accessed January 18, 2011).

U.S. Marine Corps Combat Development Command. *Field Manual, 3-24: Counterinsurgency*. Washington, D.C.: Department of the Navy, 2006.

United Nations Industrial Development Organization. *Prospects for the Development of the Construction Industry*. Vienna: United Nations, 1993.

United States Air Force Museum. *Factsheets: WWII Nissen Hut*.
<http://www.nationalmuseum.af.mil/factsheets/factsheet.asp?id=923> (accessed January 14, 2011).

United States Office of Management and Budget. *Federal Acquisition Regulation, Part 46-Quality Assurance*. 2011.

<https://www.acquisition.gov/far/current/html/FARTOCP46.html#wp226846> (accessed March 1, 2011).

—. *Federal Acquisition Regulation, Subpart 36.5-Contract Clauses*. 2011.

https://www.acquisition.gov/far/current/html/Subpart%2036_5.html#wp1076733 (accessed March 1, 2011).

—. *Federal Acquisition Regulation, Subpart 46.2-Contract Quality Requirements*. 2011.

https://www.acquisition.gov/far/current/html/Subpart%2046_2.html#wp1069847 (accessed March 1, 2011).

—. *Federal Acquisition Regulation (FAR) Home Page*. January 12, 2011.

<https://www.acquisition.gov/Far/> (accessed January 17, 2011).

Wells, J. *The Construction Industry in Developing Countries: Alternative Strategies for Development*. London: Croom Helm, 1987.

World Bank. *World Development Report. Sustainable Development in a Dynamic World*, Baltimore: Barton Matheson Willse & Worthington, 1993.

youtube.com. *YouTube - Vehicle Borne IED (Dump Truck)*. December 9, 2007.

<http://www.youtube.com/watch?v=vzJCbQVmVGw> (accessed March 5, 2011).

End Notes

¹ David H. Petraeus, "COMISAF's Counterinsurgency Guidance," Headquarters, International Security Assistance Force, United States Forces – Afghanistan, Kabul, Afghanistan (August 1, 2010), http://www.nato.int/isaf/docu/official_texts/counterinsurgency_guidance.pdf (accessed January 6, 2011).

² United Nations Industrial Development Organization, *Prospects for the Development of the Construction Industry*, Vienna: United Nations, 1993.

³ World Bank, *World Development Report*, "Sustainable Development in a Dynamic World," Baltimore: Barton Matheson Willse & Worthington, 1993.

⁴ Richard H. Clough and Glenn A. Sears, *Construction Contracting*, New York: John Wiley and Sons, 1994, p.2.

⁵ World Bank, *World Development Report*, "Sustainable Development in a Dynamic World," Baltimore: Barton Matheson Willse & Worthington, 1993.

⁶ J. Wells, *The Construction Industry in Developing Countries: Alternative Strategies for Development*, London: Croom Helm, 1987.

⁷ F. Moavenzadeh, "The Construction Industry and Economic Growth," *Asian National Development*, June/July 1984: 56-60.

⁸ Special Inspector General for Afghanistan Reconstruction (SIGAR), "Contract Oversight Capabilities of the Defense Department's Combined Security Transition Command-Afghanistan (CSTC-A) Need Strengthening," *Report to the United States Congress*, Arlington: SIGAR, 2010.

⁹ U.S. Central Command, "Society of American Military Engineers: Tampa Bay, FL Post," *Society of American Military Engineers*, January 16, 2011, <http://posts.same.org/tbaypost/Past%20meetings%20presentations/CENTCOM%20Eng%20Brief%20-%20AUG10.pdf> (accessed January 18, 2011).

¹⁰ Government Accountability Office (GAO), *Afghanistan Reconstruction: Deteriorating Security and Limited Resources Have Impeded Progress; Improvements in U.S. Strategy Needed* (Washington, D.C., June 2, 2004), http://www.gao.gov/new_items/d04403.pdf

¹¹ Special Inspector General for Afghanistan Reconstruction (SIGAR), "Contract Oversight Capabilities of the Defense Department's Combined Security Transition Command-Afghanistan (CSTC-A) Need Strengthening," *Report to the United States Congress*, Arlington: SIGAR, 2010.

¹² *Ibid*, 3

¹³ *Ibid*, 3

-
- ¹⁴ David H. Petraeus, "COMISAF's Counterinsurgency Guidance," Headquarters, International Security Assistance Force, United States Forces – Afghanistan, Kabul, Afghanistan (August 1, 2010), http://www.nato.int/isaf/docu/official_texts/counterinsurgency_guidance.pdf (accessed January 6, 2011).
- ¹⁵ U.S. Marine Corps Combat Development Command, *Field Manual, 3-24: Counterinsurgency*, Washington, D.C.: Department of the Navy, 2006.
- ¹⁶ Ibid, p. 5-3
- ¹⁷ World Bank, *World Development Report*, "Sustainable Development in a Dynamic World," Baltimore: Barton Matheson Willse & Worthington, 1993.
- ¹⁸ Louis Dupree, *Afghanistan*, Oxford: Oxford University Press, 1973, p. 483.
- ¹⁹ Afghanistan-Culture.com, *Burqa-Chadari, Afghan women head and body covering cloth*. <http://www.afghanistan-culture.com/burqa-chadari.html> (accessed January 16, 2011).
- ²⁰ Legena M. Malan, "Sustainable Construction in Afghanistan." Monterey: Naval Post Graduate School, September 2010, p.4.
- ²¹ Ibid, p.4
- ²² United States Air Force Museum, *Factsheets: WWII Nissen Hut*, <http://www.nationalmuseum.af.mil/factsheets/factsheet.asp?id=923> (accessed January 14, 2011).
- ²³ <http://www.history.navy.mil/faqs/faq75-1.htm> (Naval History and Heritage Command n.d.)
- ²⁴ Naval Education and Training Command, *Builder 3&2, Volume 2*, Pesacola: Naval Education and Training Professional Development and Technology Center, 1994, p.9-13
- ²⁵ Author's experience working on the engineer task force in RC-South, Afghanistan in 2009.
- ²⁶ Based on the author's experience in Afghanistan during 2009 and 2010.
- ²⁷ U.S. Army Corps of Engineers. *U.S. Army Corps of Engineers: A Brief History*. November 6, 2007. <http://www.usace.army.mil/History/Documents/Brief/index.html> (accessed January 15, 2011).
- ²⁸ Naval History and Heritage Command. *Seabee History: World War II*. <http://www.history.navy.mil/faqs/faq67-3.htm> (accessed January 15, 2011).
- ²⁹ Air Force Civil Engineer Support Agency, *Factsheets: RED HORSE history*, <http://www.afcesa.af.mil/library/factsheets/factsheet.asp?id=8760> (accessed January 15, 2011).
- ³⁰ —. *Factsheets: UNITED STATES AIR FORCE PRIME BEEF UNITS*. <http://www.afcesa.af.mil/library/factsheets/factsheet.asp?id=16797> (accessed January 15, 2011).

³¹ Ferris and Keithly, "Outsourcing the Sinews of War: Contractor Logistics," *MILITARY REVIEW*, Sept-Oct 2001, p.72.

³² Remarks by Robert St. Onge, Maj. Gen. (U.S.A., ret.), George Washington University conference, "Contractors on the Battlefield: Learning From the Experience in Iraq," 28 Jan. 2005

³³ U.S. Army Material Command (AMC), "Pamphlet No. 700-300: Logistics Civil Augmentation Program

(LOGCAP)" Aug. 2003, 4. LOGCAP was initiated by Army Regulation (AR) 700-137 in December 1985.

³⁴ Higgins, "Civilian Augmentation of Joint Operations," *Army Logistician*, vol. 35, Jan.-Feb. 2003

³⁵ Based on author and other military officer's experience.

³⁶ Headquarters United States Central Command, *Construction and Base Camp Development in the US CENTCOM Area of Responsibility*, MacDill Air Force Base: Headquarters United States Central Command, 2009.

³⁷ Based on the author's experience in Afghanistan in 2009 as a military engineer at Kandahar Airfield executing construction projects.

³⁸ Based on the author's experience in Iraq in 2006 submitting ONS to the JFUB for Naval Special Warfare Task Group – Arabian Peninsula.

³⁹ United States Office of Management and Budget. *Federal Acquisition Regulation (FAR) Home Page*. January 12, 2011. <https://www.acquisition.gov/Far/> (accessed January 17, 2011)

⁴⁰ Based on author's experience as a naval officer with 10 years executing construction for the Navy, and as one certified as level 1 acquisition professional by the Defense Acquisition University.

⁴¹ Headquarters United States Central Command, *Construction and Base Camp Development in the US CENTCOM Area of Responsibility*, MacDill Air Force Base: Headquarters United States Central Command, 2009.

⁴² Headquarters United States Central Command, *Construction and Base Camp Development in the US CENTCOM Area of Responsibility*, MacDill Air Force Base: Headquarters United States Central Command, 2009, 5-4.

⁴³ Moshe Schwartz, "Department of Defense Contractors in Iraq and Afghanistan: Background and Analysis," *Congressional Research Service*. July 2, 2010. <http://www.fas.org/sgp/crs/natsec/R40764.pdf> (accessed January 18, 2011).

⁴⁴ Legena M. Malan, "Sustainable Construction in Afghanistan." Monterey: Naval Post Graduate School, September 2010.

⁴⁵ Albert Szabo, Thomas J. Barfield, and Edward F. Sekler, *Afghanistan: An Atlas of Indigenous Domestic Architecture*. Austin: University of Texas Press, 1991, p. 111-155

⁴⁶ Legena M. Malan, "Sustainable Construction in Afghanistan." Monterey: Naval Post Graduate School, September 2010, as quoted from (Szabo 1991)

⁴⁷ Ibid, 28 as quoted from (Szabo 1991)

⁴⁸ Ibid, 27-28

⁴⁹ Nigel Borton and John Nicholds. "The Changing Role of NGOs in the Provision of Relief and Rehabilitation Assistance: Case Study." *Overseas Development Institute*. 1994.
<http://www.odi.org.uk/resources/details.asp?id=2561&title=changing-role-ngos-provision-relief-rehabilitation-assistance-1-afghanistan-pakistan> (accessed January 20, 2011), p 65.

⁵⁰ Ministry of Economy NGO Department, <http://www.ngo-dept.gov.af>

⁵¹ Afghan Ministry of Finance data, quoted in Matt Waldman, "Falling Short: Aid Effectiveness in Afghanistan," ACBAR Advocacy Series (ACBAR, March 2008),
[http://www.acbar.org/ACBAR%20Publications/ACBAR%20Aid%20Effectiveness%20\(25%20Mar%2008\).pdf](http://www.acbar.org/ACBAR%20Publications/ACBAR%20Aid%20Effectiveness%20(25%20Mar%2008).pdf), 24

⁵² Emile Jelinek, "A Study of NGO Relations with Government and Communities in Afghanistan," Agency Coordinating Body for Afghan Relief (ACBAR) (November 2006): 15.

⁵³ Oxfam, "Afghanistan: Development and Humanitarian Priorities," (Oxfam, January 2008)
http://www.oxfam.org.uk/resources/policy/conflict_disasters/downloads/afghanistan_priorities.pdf

⁵⁴ Islamic Republic of Afghanistan: Ministry of Economy: NGO Department, "Law on Non-Governmental Organizations, http://www.ngo-dept.gov.af/PDF/NGO_LAW/Afghan_NGO_LAW%20ENG.pdf.

⁵⁵ Waisova, "Post-War Reconstruction in Afghanistan and the Changing NGO-Government Relationship," 81.

⁵⁶ The Bonn Agreement, <http://www.afghanistangovernment.com/AfghanAgreementBonn.htm>.

⁵⁷ David H. Petraeus, "COMISAF's Counterinsurgency Guidance," Headquarters, International Security Assistance Force, United States Forces – Afghanistan, Kabul, Afghanistan (August 1, 2010), http://www.nato.int/isaf/docu/official_texts/counterinsurgency_guidance.pdf (accessed January 6, 2011).

⁵⁸ Ibid

⁵⁹ Special Inspector General for Afghanistan Reconstruction (SIGAR), "Contract Oversight Capabilities of the Defense Department's Combined Security Transition Command-Afghanistan (CSTC-A) Need Strengthening," *Report to the United States Congress*, Arlington: SIGAR, 2010.

⁶⁰ Ibid.

⁶¹ United States Office of Management and Budget, *Federal Acquisition Regulation, Subpart 46.2-Contract Quality Requirements*, 2011.

https://www.acquisition.gov/far/current/html/Subpart%2046_2.html#wp1069847 (accessed March 1, 2011).

⁶² United States Office of Management and Budget, *Federal Acquisition Regulation, Part 46-Quality Assurance*, 2011,

<https://www.acquisition.gov/far/current/html/FARTOCP46.html#wp226846> (accessed March 1, 2011).

⁶³ United States Office of Management and Budget, *Federal Acquisition Regulation, Subpart 36.5-Contract Clause*, 2011,

https://www.acquisition.gov/far/current/html/Subpart%2036_5.html#wp1076733 (accessed March 1, 2011).

⁶⁴ youtube.com, *YouTube - Vehicle Borne IED (Dump Truck)*, December 9, 2007.

<http://www.youtube.com/watch?v=vzJCbQVmVGw> (accessed March 5, 2011).

⁶⁵ Made-in-China.com. *Modular Building in Afghanistan - China Office Container, Accomodation Container, Living Container*. 2011. <http://cnstarhouse.en.made-in-china.com/product/jqCxvXKoygVu/China-Modular-Building-in-Afghanistan.html> (accessed February 27, 2011) and Corimec Italiana S.p.A., member of the Casti Group. *CORIMEC: Mission*. 2011. http://www.corimec.com/c_e-mission.htm (accessed March 5, 2011). The author witnessed erection of both types of RLBs used in Afghanistan for U.S. troop berthing.

⁶⁶ U.S. Central Command. "Society of American Military Engineers: Tampa Bay, FL Post." *Society of American Military Engineers*. January 16, 2011.

<http://posts.same.org/tbaypost/Past%20meetings%20presentations/CENTCOM%20Eng%20Brief%20-%20AUG10.pdf> (accessed January 18, 2011).

⁶⁷ Section 169, Title 10 of the U.S. Code, <http://uscode.house.gov/download/pls/10C169.txt>, (accessed February 17, 2011).

⁶⁸ Made-in-China.com, *Modular Building in Afghanistan - China Office Container, Accomodation Container, Living Container*, 2011. <http://cnstarhouse.en.made-in-china.com/product/jqCxvXKoygVu/China-Modular-Building-in-Afghanistan.html> (accessed February 27, 2011).

⁶⁹ Neil Gussman, *Armynow.com*, May 18, 2009, <http://armynow.blogspot.com/2009/05/home-sweet-trailer-home.html> (accessed February 27, 2011).

⁷⁰ Relyant, *Relocatable Buildings (RLBs)*, 2011,
<http://www.gorelyant.com/relocatablebuildingsproject> (accessed February 27, 2011).

⁷¹ Reprinted from Szabo, Barfield, and Sekler, *Afghanistan: An Atlas of Indigenous Domestic Architecture*, 119.

⁷² Ibid, 123.

⁷³ Ibid, 127.

⁷⁴ Ibid, 135.

⁷⁵ Reprinted from Legina Malan, "Sustainable Construction in Afghanistan." Monterey: Naval Post Graduate School, September 2010, 101.

⁷⁶ Ibid, 101.

⁷⁷ Reprinted from Szabo, Barfield, and Sekler, *Afghanistan: An Atlas of Indigenous Domestic Architecture*, 141.

⁷⁸ Ibid, 149.