



**SIMULATING F-22 HEAVY MAINTENANCE AND  
MODIFICATIONS WORKFORCE MULTI-SKILLING**

THESIS

Wesley A. Sheppard Jr., Captain, USAF

AFIT-ENS-14-M-28

DEPARTMENT OF THE AIR FORCE  
AIR UNIVERSITY

***AIR FORCE INSTITUTE OF TECHNOLOGY***

---

---

Wright-Patterson Air Force Base, Ohio

**DISTRIBUTION STATEMENT A.**  
APPROVED FOR PUBLIC RELEASE; DISTRIBUTION IS UNLIMITED.

The views expressed in this thesis are those of the author and do not reflect the official policy or position of the United States Air Force, Department of Defense, or the United States Government.

AFIT-ENS-14-M-28

SIMULATING F-22 HEAVY MAINTENANCE AND MODIFICATIONS  
WORKFORCE MULTI-SKILLING

THESIS

Presented to the Faculty

Department of Operational Sciences

Graduate School of Engineering and Management

Air Force Institute of Technology

Air University

Air Education and Training Command

In Partial Fulfillment of the Requirements for the  
Degree of Master of Science in Logistics and Supply Chain Management

Wesley A. Sheppard Jr., BS

Captain, USAF

March 2014

**DISTRIBUTION STATEMENT A.**  
APPROVED FOR PUBLIC RELEASE; DISTRIBUTION IS UNLIMITED.



## **Abstract**

The Air Force faces significant fiscal challenges in the coming years. The aircraft maintenance depot activities at Ogden ALC, Oklahoma City ALC and Warner-Robins ALC face complex operating environments due to the diversity of aircraft or mission design series (MDS) maintained by each depot and the variability of maintenance requirements for each MDS. Further complicating their operations is the variability of maintenance actions required from one aircraft to another within each MDS and a highly specialized workforce that has inherent inflexibility to compensate for the workload variability. Air Force Materiel Command is reviewing maintenance personnel multi-skilling as a method to efficiently absorb the variability of workload and maintenance requirements between aircraft.

This research conducts an objective analysis of the F-22 Heavy Maintenance Modification Program by building a discrete event simulation in ARENA 14® and performing a series of designed experiments. The study analyzes whether using a multi-skilled (flexible) workforce will have an impact on productivity of depot maintenance personnel through simulation of several multi-skilling policies. The research shows that multi-skilling policies can significantly outperform overtime-based production timelines at less cost, even if individual skill proficiencies decline.

*To my Savior, Jesus Christ, who sustained me during this challenging effort. In Matthew 11:28-30 He states “Come to me, all you who are weary and burdened, and I will give you rest. Take my yoke upon you and learn from me, for I am gentle and humble in heart, and you will find rest for your souls. For my yoke is easy and my burden is light.”*

*To my loving wife and children, for their support and sacrifices during this journey.*

## **Acknowledgments**

I would like to express my gratitude to my research advisor, Dr. Alan Johnson, for his direction and occasional throat punch during this research effort. I would also like to thank Dr. John O. Miller for his honest feedback and guidance, even though my dominating height makes me superior at basketball and Dr. Kenneth Schultz for his constant challenge to consider the entire spectrum of factors influencing a problem. I am also thankful to my sponsor, Mr. Steve McBride, from Air Force Material Command for both the insights and autonomy during this effort.

Finally, I am indebted to Mr. Thomas Hales and his entire team within the F-22 Heavy Maintenance and Modification Program. Special thanks to Mr. Ben Bell, Mr. Brett Bradshaw, Mr. Ron Wise, and Mr. Matt Starkey for having the patience to answer the thousand questions about their processes and continual requests for information/data. The F-22 Heavy Maintenance and Modification Program team gave me a deep respect for the valuable contribution our depot maintenance personnel provide to our National Defense and the significant challenges they face.

Wesley A. Sheppard Jr.



## Table of Contents

	<b>Page</b>
Abstract.....	iv
DEDICATION .....	v
Acknowledgments .....	vi
I. Introduction .....	1
Background.....	1
Research Focus.....	2
Problem Statement .....	2
Research Objectives & Questions:.....	4
Methodology.....	4
Assumptions .....	5
Implications .....	5
II. Literature Review.....	6
Chapter Overview.....	6
Background on Multi-skilling .....	6
Simulation.....	8
Defined.....	8
Model Fidelity .....	11
Measures of Success.....	13
Verification & Validation .....	14
Design of Experiments .....	18
Marginal Analysis.....	20
Selecting the Best Alternative .....	21
Works in Depot Maintenance, Aircraft Maintenance, and Multi-skilling Simulation.....	25
III. Methodology .....	28
Chapter Overview.....	28
F-22 Heavy Maintenance Modification Program.....	28
Model Development.....	33
Scope Decision .....	34
Conceptualization.....	38

Model Assumptions, Constraints, and Limitations.....	40
Model Description .....	43
Characteristics Sub Model .....	45
Gate 1 Sub Model.....	46
Inputs.....	58
Resources .....	58
Data .....	60
Model Verification & Validation .....	69
Verification.....	69
Validation.....	71
Marginal Analysis.....	78
IV. Results and Analysis .....	81
Chapter Overview.....	81
Current State .....	81
Personnel Add Marginal Analysis.....	81
All AP Multi-skill Analysis.....	85
Targeted Multi-skill Analysis .....	88
Current State – Results Summary .....	91
Future State.....	93
Personnel Reduction Analysis .....	94
Targeted Multi-skill Analysis .....	95
Multi-skilled Personnel Add Analysis .....	98
Future State – Results Summary .....	101
V. Conclusions and Recommendations.....	104
Answers to Research Questions .....	104
Limitations .....	106
Future Research.....	107
Appendix A-Model Description .....	109
Full Model Description .....	109
Characteristics Sub Model .....	110
Gate 1 Sub Model.....	112
Gate Sub Model Differences .....	133

Set Availability Calculation Models .....	139
Final Value Record Models.....	141
Appendix B- Validation Data .....	145
Flow Day Validation.....	145
Appendix C- Analysis Results .....	146
Current State- Manpower Add.....	146
Future State.....	155
Targeted Multi-skill Analysis .....	155
Multi-skill Add – 15 Percent Targeted Experiment 6.....	156
Multi-skill Add – 15 Percent Targeted Experiment 9 (E9).....	160
Bibliography .....	167

## List of Figures

	Page
FIGURE 1: STEPS IN A SIMULATION STUDY (BANKS ET AL, 2010) .....	11
FIGURE 2: GATE EXAMPLE.....	30
FIGURE 3: BASIC PROCESS FLOW .....	39
FIGURE 4: TOP LEVEL MODEL.....	44
FIGURE 5: CHARACTERISTICS SUB MODEL.....	45
FIGURE 6: GATE 1 SUB MODEL .....	47
FIGURE 7: GATE 1 SUB MODEL (A).....	48
FIGURE 8: AV_PROCESSG1 (GATE 1 SUB MODEL).....	51
FIGURE 9: AV1 NUMBER (AV_PROCESSG1 SUB MODEL).....	52
FIGURE 10: GATE 1 SUB MODEL (B).....	55
FIGURE 11: CONTINUE AV?.....	56
FIGURE 12: GATE 1 AV RE-LOOP AND EXIT PATH .....	57
FIGURE 13: AP CUMULATIVE STANDARD HOURS.....	62
FIGURE 14: AP CUMULATIVE ADJUSTED STANDARD HOURS .....	65
FIGURE 15: 2014 PROJECTED F-22 HOURS (BINS).....	66
FIGURE 16: FUTURE STATE PROJECTED F-22 HOURS .....	68
FIGURE 17: RUN LENGTH & REP COMPARISON .....	73
FIGURE 18: CURRENT STATE – TARGETED MULTI-SKILLING JMP® ONEWAY ANALYSIS .....	90
FIGURE 19: FUTURE STATE - TARGETED MULTI-SKILL ONEWAY ANALYSIS.....	98
FIGURE 20: TOP LEVEL MODEL.....	109
FIGURE 21: CHARACTERISTICS SUB MODEL .....	110
FIGURE 22: ASSIGN_PLANE1.....	111
FIGURE 23: RECORD_PLANE1.....	112
FIGURE 24: MX_DOCK_SEIZE1.....	112
FIGURE 25: GATE 1 SUB MODEL.....	113
FIGURE 26: GATE 1 SUB MODEL (A).....	114
FIGURE 27: GATE1_AV.....	115
FIGURE 28: AV_PROCESSG1 (GATE 1 SUB MODEL).....	117
FIGURE 29: AV1 NUMBER (AV_PROCESSG1 SUB MODEL).....	118
FIGURE 30: AV_DI PROCESS .....	122
FIGURE 31: AVIONICS_AV RESOURCE SET .....	123
FIGURE 32: AV_LABORHOURS_G1 .....	124
FIGURE 33: GATE 1 SUB MODEL (B).....	126
FIGURE 34: GATE1MATCH.....	127
FIGURE 35: DECIDE AV1_LOOP.....	128
FIGURE 36: GATE1_AVMATCH .....	129
FIGURE 37: CONTINUE AV?.....	130
FIGURE 38: GATE 1 AV RE-LOOP AND EXIT PATH .....	131
FIGURE 39: GATE1_AV_HOURS.....	131
FIGURE 40: GATE1_BATCH.....	132
FIGURE 41: GATE1_DAYS.....	133
FIGURE 42: GATE1_HOURS.....	133
FIGURE 43: GATE2_CUMULATEDAYS.....	134
FIGURE 44: GATE4MINHOLD .....	135
FIGURE 45: MX_DOCK_RELEASEG4.....	136
FIGURE 46: PLANETYPESTATS SUB MODEL.....	137
FIGURE 47: DECIDEPLANETYPESTATS.....	138
FIGURE 48: SET AVAILABILITY CALCULATION MODELS .....	140
FIGURE 49: FINAL VALUE RECORD MODEL .....	142

FIGURE 50: AV_MULTI-SKILL_USETOTAL.....	143
FIGURE 51: STATISTIC RESET MODEL.....	143
FIGURE 52: CLEMSON SCHEDULING TOOL (MORS) EXAMPLE.....	144
FIGURE 53: MANPOWER CURRENT STATE - EXPERIMENT A1 JMP® ANOVA .....	146
FIGURE 54: MANPOWER CURRENT STATE - EXPERIMENT A1 JMP® TUKEY-KRAMER HSD .....	146
FIGURE 55: MANPOWER EXPERIMENT A2 JMP® ANOVA .....	147
FIGURE 56: MANPOWER CURRENT STATE - EXPERIMENT A2 JMP® TUKEY-KRAMER HSD .....	147
FIGURE 57: MANPOWER CURRENT STATE - EXPERIMENT A3 JMP® ANOVA .....	148
FIGURE 58: MANPOWER CURRENT STATE - EXPERIMENT A3 JMP® TUKEY-KRAMER HSD .....	148
FIGURE 59: MANPOWER CURRENT STATE - EXPERIMENT A4 JMP® ANOVA .....	149
FIGURE 60: MANPOWER CURRENT STATE - EXPERIMENT A4 JMP® TUKEY-KRAMER HSD .....	149
FIGURE 61: MANPOWER CURRENT STATE - EXPERIMENT A5 JMP® ANOVA .....	150
FIGURE 62: MANPOWER CURRENT STATE - EXPERIMENT A5 JMP® TUKEY-KRAMER HSD .....	150
FIGURE 63: MANPOWER CURRENT STATE - EXPERIMENT A6 JMP® ANOVA .....	151
FIGURE 64: MANPOWER CURRENT STATE - EXPERIMENT A6 JMP® TUKEY-KRAMER HSD .....	151
FIGURE 65: MANPOWER CURRENT STATE - EXPERIMENT A7 JMP® ANOVA .....	152
FIGURE 66: MANPOWER CURRENT STATE - EXPERIMENT A7 JMP® TUKEY-KRAMER HSD .....	152
FIGURE 67: MANPOWER CURRENT STATE - EXPERIMENT A8 JMP® ANOVA .....	153
FIGURE 68: MANPOWER CURRENT STATE - EXPERIMENT A8 JMP® TUKEY-KRAMER HSD .....	153
FIGURE 69: MANPOWER CURRENT STATE - EXPERIMENT A9 JMP® ANOVA .....	154
FIGURE 70: MANPOWER CURRENT STATE - EXPERIMENT A9 JMP® TUKEY-KRAMER HSD .....	154
FIGURE 71: FUTURE STATE – TARGETED MULTI-SKILL JMP® TUKEY-KRAMER HSD .....	155
FIGURE 72: FUTURE STATE – (E6) ADD EXPERIMENT F1 JMP® ANOVA .....	156
FIGURE 73: FUTURE STATE – (E6) ADD EXPERIMENT F1 JMP® STUDENT’S T & TUKEY-KRAMER HSD .....	156
FIGURE 74: FUTURE STATE – (E6) ADD EXPERIMENT F2 JMP® ANOVA .....	157
FIGURE 75: FUTURE STATE – (E6) ADD EXPERIMENT F2 JMP® STUDENT’S T & TUKEY-KRAMER HSD .....	157
FIGURE 76: FUTURE STATE – (E6) ADD EXPERIMENT F3 JMP® ANOVA .....	158
FIGURE 77: FUTURE STATE – (E6) ADD EXPERIMENT F3 JMP® STUDENT’S T & TUKEY-KRAMER HSD .....	158
FIGURE 78: FUTURE STATE – (E6) ADD EXPERIMENT F4 JMP® ANOVA .....	159
FIGURE 79: FUTURE STATE – (E6) ADD EXPERIMENT F3 JMP® STUDENT’S T & TUKEY-KRAMER HSD .....	159
FIGURE 80: FUTURE STATE – (E9) ADD EXPERIMENT G1 JMP® ANOVA .....	160
FIGURE 81: FUTURE STATE – (E9) ADD EXPERIMENT G1 JMP® STUDENT’S T & TUKEY-KRAMER HSD .....	160
FIGURE 82: FUTURE STATE – (E9) ADD EXPERIMENT G2 JMP® ANOVA .....	161
FIGURE 83: FUTURE STATE – (E9) ADD EXPERIMENT G2 JMP® STUDENT’S T & TUKEY-KRAMER HSD .....	161
FIGURE 84: FUTURE STATE – (E9) ADD EXPERIMENT G3 JMP® ANOVA .....	162
FIGURE 85: FUTURE STATE – (E9) ADD EXPERIMENT G3 JMP® STUDENT’S T & TUKEY-KRAMER HSD .....	162
FIGURE 86: FUTURE STATE – (E9) ADD EXPERIMENT G4 JMP® ANOVA .....	163
FIGURE 87: FUTURE STATE – (E9) ADD EXPERIMENT G4 JMP® STUDENT’S T & TUKEY-KRAMER HSD .....	163
FIGURE 88: FUTURE STATE – (E9) ADD EXPERIMENT G5 JMP® ANOVA .....	164
FIGURE 89: FUTURE STATE – (E9) ADD EXPERIMENT G5 JMP® STUDENT’S T & TUKEY-KRAMER HSD .....	164
FIGURE 90: FUTURE STATE – (E9) ADD EXPERIMENT G6 JMP® ANOVA .....	165
FIGURE 91: FUTURE STATE – (E9) ADD EXPERIMENT G6 JMP® STUDENT’S T & TUKEY-KRAMER HSD .....	165
FIGURE 92: FUTURE STATE – (E9) ADD EXPERIMENT G7 JMP® ANOVA .....	166
FIGURE 93: FUTURE STATE – (E9) ADD EXPERIMENT G7 JMP® STUDENT’S T & TUKEY-KRAMER HSD .....	166

## List of Tables

	<b>Page</b>
TABLE 1: CURRENT STATE PERSONNEL RESOURCES.....	60
TABLE 2: AP HOURS STANDARD VS ACTUAL.....	64
TABLE 3: INPUTS-2014 PROJECTION BINS.....	67
TABLE 4: FUTURE STATE INPUT PERCENTAGES.....	68
TABLE 5: REPLICATION CALCULATION FOR PRECISION .....	74
TABLE 6: CURRENT STATE VALIDATION - EXPECTED VS. MODEL FLOW DAYS.....	76
TABLE 7: FUTURE STATE VALIDATION - EXPECTED VS MODEL FLOW DAYS.....	76
TABLE 8: CURRENT STATE - PERSONNEL ADD.....	82
TABLE 9: CURRENT STATE – PERSONNEL ADD GATE ANALYSIS .....	84
TABLE 10: CURRENT STATE – ALL AP MULTI-SKILL ANALYSIS.....	86
TABLE 11: CURRENT STATE – AP ALL MULTI-SKILL GATE ANALYSIS.....	87
TABLE 12: CURRENT STATE - TARGETED MULTI-SKILL ANALYSIS .....	89
TABLE 13: CURRENT STATE - RESULTS SUMMARY.....	92
TABLE 14: FUTURE STATE - PERSONNEL REDUCTION .....	94
TABLE 15: FUTURE STATE – MULTI-SKILL TARGETED ANALYSIS (15% REDUCTION).....	96
TABLE 16: FUTURE STATE – 15% REDUX TARGETED MULTI-SKILLING ADD (E6).....	99
TABLE 17: FUTURE STATE – 15% REDUX TARGETED MULTI-SKILLING ADD (E9).....	100
TABLE 18: FUTURE STATE – RESULTS SUMMARY.....	102
TABLE 19: CURRENT STATE VALIDATION.....	145
TABLE 20: FUTURE STATE VALIDATION.....	145

# SIMULATING F-22 HEAVY MAINTENANCE AND MODIFICATIONS WORKFORCE MULTI-SKILLING

## I. Introduction

### Background

The Air Force faces significant fiscal challenges in the coming years with dwindling defense spending and increasing procurement and sustainability costs associated with more technologically advanced weapons systems and an aging legacy fleet. The Air Force Sustainment Center and the three Air Logistics Complexes (ALCs) under their purview are at the forefront of the battle to affect the cost curve for sustainment operations.

The aircraft maintenance depot activities at Ogden ALC, Oklahoma City ALC and Warner-Robins ALC face complex operating environments due to the diversity of aircraft or mission design series (MDS) maintained by each depot and the variability of maintenance requirements for each MDS. Further complicating their operations is the variability of maintenance actions required from one aircraft to another within each MDS and a highly specialized workforce that has inherent inflexibility to compensate for the workload variability.

Multi-skilling is one proposal that Air Force Materiel Command is reviewing to absorb the variability of workload and maintenance requirements between aircraft.

Multi-skilling is defined as “a position that combines two or more journeyman, full performance or higher level skills in the same pay plan in which formal on-the-job or

classroom training is required” (Federal Service Impasse Panel, 1997). In 1993, the Oklahoma City ALC implemented a multi-skill program, an initiative similar to private aircraft and manufacturing industries’ directional shift towards more flexible workforces (Federal Service Impasse Panel, 1997). The program never materialized in the way designed and therefore had negligible results. According to a report by the Air Force Journal of Logistics (2003), the benefits of multi-skilling in the program were not realized due to lack of supervisory understanding on how to use multi-skill employees and lack of incentives for personnel to become multi-skilled. The question remains unanswered on whether Air Force depot operations can more cost effectively use their work force through multi-skilling.

### **Research Focus**

The goal of this research is to provide a quantitative analysis on whether a multi-skilled workforce allows for more cost effective use of ALC maintenance personnel. The focus of this research is not on the shortcomings of previous multi-skilling efforts or methods for implement multi-skilling but on the potential benefits of a more flexible workforce.

Specifically, AFMC/A4D requests this research to focus on the F-22 Heavy Maintenance Modification Program at Ogden ALC and estimate whether their operations will benefit from a more flexible, multi-skilled workforce.

### **Problem Statement**

The F-22 Heavy Maintenance Modification Program consists of several Federal Wage Series occupations or maintenance specialties that perform maintenance on the

F-22 depot production line. According to a business case analysis (BCA) on a Multi-Trade Demonstration project completed by Ogden ALC (2012), the F-22 flight is currently experiencing indirect labor rates over 50 percent and direct overtime rates over 15 percent. The overtime hours equate to a projected \$9.8 million dollars in overtime costs for the 5-year period of 2013 to 2017 (Ogden Air Logistics Center, 2012). The business case analysis hypothesizes that the problems lies in the WG-4102 Painter (Low Observable or LO) workforce constraints and associated downtime of other occupations awaiting LO task completion. Their report identifies that LO coating related man-hour requirements account for 60 percent of the total man-hour requirements (Ogden Air Logistics Center, 2012).

The cost associated with overtime and idle personnel created by the LO labor-hour constraint appears to create an opportunity for potential productivity gains through multi-skill initiatives by increasing the availability of WG-4102 Painter labor hours. No substantive analysis exists on which maintenance specialties within F-22 depot operations are favorable for multi-skilling into the LO specialty. The literature review for this research contains further analysis of the Multi-Trade Demonstration Project business case analysis.

Additionally, no quantitative analysis exists to ascertain the aircraft throughput and employee utilization impacts of multi-skilling other than a limited simulation of the KC-135 IDOCK depot process by Levien (2010). Will creating a flexible workforce increase productivity, aircraft throughput, and decrease indirect labor hours?

## **Research Objectives & Questions:**

The research will provide insight into career fields that should be considered for multi-skilling into LO and the impact on F-22 throughput within the depot process. Subject matter experts (SMEs) from Ogden Air Logistics Complex, previous research in queuing theory, and the research questions developed will be the foundation for the direction of the research and the desired output parameters selected for analysis. The following research questions drive the direction taken in this study.

**Research Question 1:** Which maintenance specialties within F-22 Depot Operations should be considered for multi-skilling into the low observable (LO) specialty?

**Research Question 2:** How does multi-skilling affect aircraft throughput and employee utilization in F-22 Depot Operations?

**Research Question 3:** To what extent does multi-skilling offset overtime use to meet aircraft flow day requirements and throughput targets?

## **Methodology**

The research will conduct an objective analysis of the F-22 Heavy Maintenance Modification Program by building a discrete event simulation in ARENA 14® and performing a series of designed experiments. The study analyzes whether using a multi-skilled workforce will have an impact on productivity of depot maintenance personnel by simulating several multi-skilling policies.

## **Assumptions**

The only assumption at the start of the research is that SME feedback is accurate and uninfluenced by outside pressures.

## **Implications**

The implications of the research could be significant for Air Force Material Command. The Air Force recently announced that the F-22 Heavy Maintenance Modification Program workload is going to double within the next 12 months as depot maintenance activities previously performed at a facility in Palmdale, CA relocate to Ogden ALC (United States Air Force, 2013). The multi-skilling analysis and results from this research could save the Air Force millions of dollars, either by guiding to the right decision or by preventing the wrong one. Additionally, decisions about future weapon systems depot maintenance specialties and their future workforce structures will benefit from the results of this research.

## **II. Literature Review**

### **Chapter Overview**

The review of literature for this study encompasses a background on multi-skilling, simulation, different analysis methods, and previous simulation research in maintenance and cross-training policies. The review starts by reviewing the proposed policy of multi-skilling within the United States Air Force.

### **Background on Multi-skilling**

Multi-skilling is previously defined as “a position that combines two or more journeyman, full performance or higher level skills in the same pay plan in which formal on-the-job or classroom training is required” (Federal Service Impasse Panel, 1997). The intent of multi-skilling is to buffer variability in depot maintenance workloads by providing a flexible workforce that is able to work other specialty’s tasks during periods of non-utilization or to provide surge capacity during periods with higher workloads in one specialty, effectively balancing the workload.

The concept is similar to flexible workforce strategies adopted by commercial carriers and private sector maintenance repair organizations (MROs). The commercial carriers and MROs hire Airframe and Powerplant (A&P) certified maintenance technicians and allow them to complete most maintenance tasks during major maintenance operations. Part of the benefit of being A&P certified is that the employees are compensated with a higher wage for their increased qualifications. The Department

of Defense is considering a similar incentive for multi-skilled employees under a proposal called multi-trade.

The 2008 National Defense Authorization Act authorized the Secretary of the Air Force (SECAF) to carry out a demonstration project under which workers who are certified to perform multiple trades at the journeyman level (multi-skilled) may be promoted one grade level (Ogden Air Logistics Center, 2012). The proposed project was assigned to Ogden ALC and is expected to be undertaken on positions within the F-22 Heavy Maintenance and Modification Program (Ogden Air Logistics Center, 2012). The only difference between the term multi-skill and multi-trade is that a multi-skilled employee is promoted under multi-trade by one wage grade once they are certified at the journeyman level to perform multiple trades. Ogden ALC performed a BCA in 2012 to identify the potential benefits of a multi-skilled workforce.

The BCA identifies variations in work requirements of single-skilled personnel as a factor in the peaks and valleys of resource usage within the F-22 depot process. The analysis further identifies the WG-4102 Painters with specialization in LO surface application as the “burning platform” for the multi-trade initiative due to the disproportional man-hour requirements and use of Painters (LO) versus the other Federal Wage Series (FWS) specialties (Ogden Air Logistics Center, 2012). The BCA proposes the multi-trade initiative as a way to offset overtime requirements by increasing the number of personnel available to complete LO maintenance and to increase overall efficiency of the other specialties by allowing them to work jobs that are more critical in the secondary specialty. The BCA proposes multi-skilling all non-LO personnel into LO

and all LO personnel into the non-LO specialties. The analysis further hypothesizes significant cost savings from the initiative.

The cost savings proposed by the BCA includes several million dollars a year after the initial program implementation period with continued savings in the out-years of the analysis. The analysis further proposes that the garnered cost savings/avoidance from reductions in personnel requirements will be a direct result of employing a more flexible workforce, thereby increasing utilization of all personnel and minimizing overtime requirements. With an understanding of the proposed benefits from multi-skilling/multi-trade policies, the researcher moves to a review of simulation methods and best practices.

## **Simulation**

### **Defined**

A simulation is the imitation of the operation of a future or real-world process or system over time (Banks, Carson II S, Nelson L, & Nicol M, 2010, p. 3). Banks et al. explain that many real-world systems are so complex that models of the systems are virtually impossible to solve mathematically (2010). Simulation allows for the study of those systems that are mathematically infeasible otherwise.

The benefits of simulation include having the capability to simulate potential changes to the system prior to implementation in order to gain insights into the impact of those changes on system performance (Banks et al., 2010, p. 3). Another benefit is the ability to simulate systems in the design phase prior to building the system (Banks et al., 2010). The uses for simulation are numerous but Banks et al. (2010) identify 11 purposes for simulation including:

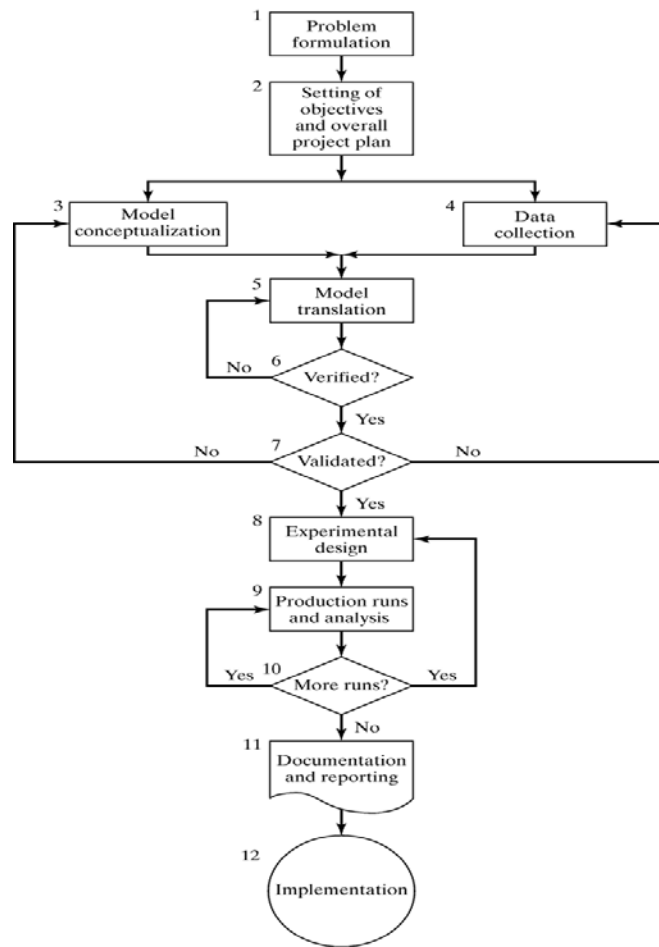
- 1) Simulation enables the study of, and experimentation with, the internal interactions of a complex system or of a subsystem within the complex system.
- 2) Informational, organizational, and environmental changes can be simulated, and the effect of these alterations on the model's behavior can be observed.
- 3) The knowledge gained during the designing of a simulation model could be of great value toward suggesting improvement in the system under investigation.
- 4) Changing simulation inputs and observing the resulting outputs can produce valuable insights about which variables are the most important and how variables interact.
- 5) Simulation can be used as a pedagogical device to reinforce analytic solution methodologies.
- 6) Simulation can be used to experiment with new designs or policies before implementation, so as to prepare for what might happen.
- 7) Simulation can be used to verify analytic solutions.
- 8) Simulating different capabilities for a machine can help determine its requirements.
- 9) Simulation models designed for training make learning possible, without the cost and disruption of on-the-job instruction.
- 10) Animation can show a system in simulated operation so that the plan can be visualized.

11) A modern system (factory, wafer fabrication plant, service organization, etc.) is so complex that its internal interactions can be treated only through simulation. ( p. 4)

Banks et al. (2010) also identify times when simulation is not appropriate including:

- 1) When the problem can be solved by common sense.
  - 2) If the problems can be solved analytically.
  - 3) If it is less expensive to perform direct experiments
  - 4) If the cost exceed the savings.
  - 5) If the resources or time are not available.
  - 6) If no data is available, not even estimates, simulation is not advised.
  - 7) If managers have unreasonable expectations
  - 8) System behavior is too complex or cannot be defined (human behavior, etc)
- (p. 4-6)

The reasons for and against using simulation should be thoroughly reviewed and considered before deciding simulation as the desired methodology. If simulation is the path selected, Bank et al. (2010) provide 12 basic steps for conducting a simulation study as depicted in Figure 1. The important concept to notice is that once the problem is formulated and the objectives for the project are set, the process retraces steps as you go and the completion of a step does not mean the step will not need to be re-accomplished later in development or during analysis. The researcher should not put the blinders on and assume that because the model was previously verified and validated that additional verification and validation is not required.



**Figure 1: Steps in a Simulation Study (Banks et al, 2010)**

### **Model Fidelity**

According to Law (2005), a simulation practitioner must determine the aspects of a system that need to be incorporated into the simulation model and what can be ignored (p. 246). He further explains that it is rarely necessary to include every element of the system in the model in order to make effective decisions, and in some cases can cause excessive model run time, causing missed deadlines and obscuring important factors (Law, 2007).

Law (2007) presents eight general guidelines for determining the level of detail required when constructing a simulation model (p. 247). The first guideline he prescribes is that models are designed for a specific purpose and the specific issues to be investigated and their corresponding measures of performance must be defined (Law, 2007, p. 247). The goal of the research is defined in Chapter 1 and must be thoroughly understood prior to model development. Law cites an example in which “a U.S. military analyst worked on a simulation model for six months without interacting with the general who requested it. At the Pentagon briefing for the study, the general walked out after 5 minutes stating, That’s not the problem I’m interested in.” (Law, 2007, p. 247)

Another relevant guideline he suggests is to “use subject-matter experts (SMEs) and sensitivity analyses to help determine the level of model detail” and scope your model to focus on the most important factors (Law, 2007, p. 247). Specifically important to this research is his statement under this guideline that, “Given a limited amount of time for model development, one should obviously concentrate on the most important factors.” (Law, 2007, p. 247) The consideration on the amount of time needed for model development relates to his guideline that most simulation studies have a time and money constraint that determines the level of detail attained in the model (Law, 2007).

In the final two guidelines Law directs the developer away from including more detail than is necessary to address the issues of interest while keeping enough to attain credibility and to ensure the model detail is consistent with the type of data that is available (Law, 2007). The summary for the guidelines prescribed by Law is to clearly define the issues of interest, to have enough detail in the model to consider all the major factors that influence the issue of interest while not including unnecessary levels of detail,

and to consider the time constraints of the study when deciding on the level of detail within the model.

### **Measures of Success**

Sadowski and Grabau define success in a simulation project as “one that delivers useful information at the appropriate time to support a meaningful decision” (2004, p. 61). They give three elements of success including the right timing, the right information, and the right decision (Sadowski & Grabau, 2004). The right information includes providing information that the study stakeholders are interested in as well as insights garnered by the simulation developer (Sadowski & Grabau, 2004, p. 61). The right timing constitutes providing meaningful information to decision makers in time to assist their decision (Sadowski & Grabau, 2004, p. 62).

The third element is making the right decision. This may be out of the researcher’s control but in order for the results to be of value they must be delivered to the right person in the right context (Sadowski & Grabau, 2004). If the study results in decision level data but never makes it to the person making decision then the study may have been for naught. Sadowski and Grabau (2004) go on to discuss the potential pitfalls and problems that keep simulation developers from attaining success and describe ways to avoid those pitfalls. One of the elements of success was influencing the right decision and in order for that to happen the decision maker (manager) needs to believe and use the results.

Little (2004) states, “The big problem with management science models is that managers practically never use them” (p. 1841). He give three reasons for what is wrong

including: 1) good models are hard to find 2) good parameterization is even harder and 3) managers do not understand the models (Little, 2004, p. 1841). As the manager digs into the study they find questionable assumptions, the study ignores qualitative aspects important to the manager and uses confusing terminology (p. 1841). Additionally, modelers tend to thrive on adding more and more detail while at the same time constructing an incomplete model due to omitting critical phenomenon (Little, 2004). Little's direction is to strive to construct a simple model that includes quite a few phenomenon (2004).

In order to assist in getting managers buy-in on model use, Little (2004) provides a "decision calculus" or a set of procedures to ensure the model is used to assist the manager in decisions (p. 1843). Little's (2004) "decision calculus" includes being simple, robust, easy to control, adaptive, complete on important issues, and easy to communicate with (p. 1843-1844). Summarizing his methods, they are designed to include the manager's view of the system and "make the model more a part of him" (Little, 2004, p. 1844). Getting the manager to have buy-in on the simulation model developed, understand the model, and trust the results will be at the forefront of this research. Proper verification and validation is one way to gain trust in the model.

### **Verification & Validation**

The reasons for using simulation can be negated if the model does not reflect real system behaviors or if the outputs do not provide useful insights into system behaviors. Deliberate verification and validation (V & V) ensures the model is designed to accurately depict the real system and its associated behaviors. According to Carson

(2005), “The results of the V & V phase is a verified, validated model that is judged to be accurate enough for experimentation purposes over the range of system designs contemplated” (p. 21). The first step in the V & V process is model verification (Banks, et al., 2010) (Carson II, 2005) (Law, 2007).

### **Verification**

According to Banks et al. (2010) stated, “The purpose of model verification is to assure that the conceptual model is reflected accurately in the operational model” (p. 390). They assert a few common-sense suggestions for the verification process including having the operational model checked by someone other than its developer, examining the model for reasonable outputs under a variety of input values, verifying that what is seen in an animated model depicts the real system (Banks et al., 2010, p. 390-391).

Banks et al. (2010) go on to discuss a common failing among students who are learning simulation, identifying that the most often overlooked suggestion “is a close and thorough examination of model output for reasonableness”(p. 391). They also suggest using a debugger to monitor the simulation as it progresses in order to focus on certain areas or events within the model (Banks et al., 2010, p. 391). An important part of the debugger suggestion, in regards to this research, is their suggestion to monitor the values or statuses of selected components, variables, attributes, etc. (Banks et al., 2010, p. 391) Monitoring the values of resources and attributes will be critical during model development to ensure the functions not visible through animation are operating properly.

Law (2007) discusses eight techniques that can be used during verification of a simulation. His first technique is to “write and debug the computer program in modules

or subprograms” (Law, 2007, p. 248). Building the simulation in a piecewise fashion and conducting verification prior to duplicating the functions will be essential to minimizing errors and catching them early in development. Law’s second technique recommends using a group of experts to review the model by conducting a “structured walk-through of the program” (2007, p. 249). This technique allows for multiple simulation experts to walk through a simulation and verify that each function is correct. Discussions with operations researchers and professors knowledgeable in simulation will be valuable to gaining further insights into the art of simulation but also to catching errors within the model developed for this research.

In his third technique Law recommends running the simulation under a variety of input parameter settings to ensure outputs remain logical (2007, p. 249). This technique falls in line with Banks et al. (2010) recommendations to continually verify and validate the model by frequently comparing model outputs to the real system. His fourth technique involves using a “trace” in which the variable or statistical values are displayed after each event and compared to real data to verify the model is operating correctly (Law, 2007). The final techniques Law (2007) recommends are to run the model with simplified assumptions to compare outputs to real system values that can be calculated, use animation to observe the simulation, compare statistical values generated from the model with historical data, and to use commercial software packages to reduce the programming required (pp. 251-253). Verification produces an operational model that should reflect the real system but does not guarantee accuracy. Model validation gives the outputs of the model accuracy and increases model credibility.

## **Validation**

Carson (2005), Law (2007), Banks et al. (2010), and Little (2004) emphasize the importance of involving managers and their teams in validating the model. Carson (2005) states, “Model validation gets the customer involved” (p. 21). Banks et al. (2010) defines validation as “the overall process of comparing the model and its behavior” and calibration as “the iterative process of comparing the model to the real system, making adjustments (or even changes) to the model, comparing the revised model to reality, making additional adjustments, comparing again, and so on” (p. 395). An important point to highlight is the recommendation by Banks et al. (2010) “for the modeler to use the main responses of interest as the primary criteria for validating the model” (p. 398). The primary responses of interest should be validated against actual data since the F-22 Heavy Maintenance Modification program is an existing system with numerous data points for comparison.

Banks et al. (2010), Law (2007), and numerous other simulation practitioners highlight the benefits of continually verifying and validating the model during development. The importance of creating a model that not only reflects the current system but also produces logical outputs as input parameters change cannot be overstated. Carson (2002) quotes the statistician George Box in saying “All models are wrong. Some are useful.” (p. 53) Proper verification and validation will ensure the simulation outputs provide system behavioral insights that can be “useful” for managerial decisions.

## **Design of Experiments**

In order to understand the cause-and-effect relationships in a system the input variables must be deliberately changed while observing the associated response changes of the output variables (Montgomery, 2013). According to Montgomery (2013), experimentation is a critical part of the scientific method and well-defined experiments can lead to an empirical model of the system (p. 3).

He also discusses statistical process design of experiments, referring to “the process of planning the experiment so that appropriate data will be collected and analyzed by statistical methods” (Montgomery, 2013, p. 11) and that research needs deliberate data collection and statistical analysis for adequate insights and results to be realized. Montgomery (2013) also provides several broad reasons for running experiments, one of which is discovery (p. 2013). Discovery is useful for trying to explore new factors or ranges of factors (Montgomery, 2013), similar to the focus of this research on discovering the new factors created by multi-skilling specialties.

Sanchez (2005) states, “A well-designed experiment allows the analyst to examine many factors than would otherwise be possible, while providing insights that could not be gleaned from trial-and-error approaches or by sampling factors one at a time” (p. 69). Her assertions focus on the key point that designing an experiment well and using the proper methods can cut down on sampling requirements significantly (Sanchez, 2005). Montgomery (2013) and Sanchez (2005) both discuss the pitfalls of adjusting one factor at a time (OFA) due to the loss of insights into the interaction effects associated with the varying levels. Both parties discuss the benefits of using factorial designs, fractional designs, and Latin hypercube designs.

The Latin hypercube design is one of interest because of its flexibility to efficiently design experiments while retaining space-filling properties of full factorial designs. The largest benefit of a Latin hypercube design is the “number of designs grows linearly with  $k$  rather than exponentially” (Sanchez, 2005, p. 76). The  $k$  refers to the number of factors considered in the experiment. The linear growth significantly reduces the number of design points needed to get accurate insights into the interactions across the factors at many levels. The downside of a randomized Latin Hypercube is that smaller designs may have pairwise correlations (Sanchez, 2005). She provides a remedy to the smaller design by introducing work on nearly orthogonal Latin hypercube (NOLH) designs by Cioppa and Lucas (2005) (Sanchez, 2005).

Cioppa and Lucas (2007) explore the benefits of using a space-filling design of experiments to gather insights on uncertain response surfaces and their application to DoD simulation modeling. Their research minimizes the unsampled regions of an experimental region while improving the space-filling properties of orthogonal Latin hypercubes for  $k \leq 67$  (Cioppa & Lucas, 2007). The ability to deal with a smaller number of factors is desirable for potential experimentation options in this research. Additionally, their research provides “readily available designs that allow analysts to explore how well a diverse set of meta-models captures the relationships between many input variables of a simulation and one or more output variables” (Cioppa & Lucas, 2007, p. 54). The NOLH design they provide assists in examination by allowing fitting of models with main, quadratic, and interaction effects with nearly uncorrelated estimates of regression coefficients for the linear term effects (Cioppa & Lucas, 2007, p. 54). The spreadsheet they implemented is available at <http://harvest.nps.edu>. Summarized, the

NOLH design allows the researcher to gain valuable insights on an unknown response surface without having to use full factorial or similar designs, which require exponentially increasing design points as factors ( $k$ ) increase.

### **Marginal Analysis**

The objective of this research is to select the best choice of personnel policies in regards to multi-skilling versus the status quo of overtime. Marginal analysis is a basic form of optimization that assists in selecting from among differing technically efficient alternatives (de Neufville, 1990, p. 41). According to de Neufville (1990), “marginal analysis combines the production function, which represents only the technically efficient production possibilities; and the input cost function, which describes the cost of inputs used” (1990, p. 41).

One of the key assumptions relating to this research is that the only constraint on resources is the money available or the budget (de Neufville, 1990). Marginal analysis is useful for optimizing the system design through simulation if the costs of inputs are readily available. The cost data for this research is available from the business case analysis completed by Ogden ALC on the proposed Multi-Trade Demonstration Project discussed earlier in this chapter (Ogden Air Logistics Center, 2012). For this study the production function represents model output changes associated with resource adjustments and will provide insights into the increases or decreases in system performance as well as the cost to get that performance.

Ysebaert (2011) used marginal analysis by implementing a “shopping list” approach to gauge the improvements of Adjusted Stock Level panels for the F-22. Her

marginal analysis measured the improvements to availability compared to the cost of an additional panel (Ysebaert, 2011). Ysebaert's results provided valuable insights into the aircraft availability improvements possible with purchases of additional panels as well as the cost of those improvements (2011). Her final analysis provided the "shopping list" or the "what to purchase next" for panels included as well as the improvement costs associated with each additional panel purchased. Similar methods are used in the Aircraft Sustainability Model (ASM) by comparing optimal spares mixes based on a target metric defined by the user (Ysebaert, 2011) (Slay, Bachman, Kline, O'Malley, Eichorn, & King, 1996). Both Ysebaert (2011) and Slay et al. (1996) use marginal analysis based on simulation outputs to decide the "benefit per dollar" and the scenarios with the highest benefit should be at the top of the "shopping list". Understanding the benefit of marginal analysis leads to the review of literature on selecting the best experimental scenario in order to gain the best value for the tax payers dollar.

### **Selecting the Best Alternative**

Comparing the different system policies of multi-skilling is the primary reason for selecting simulation as a methodology in this research. For our system, the goal is not just to compare alternatives but also to select the best of the differing alternatives through statistically proven ranking-and-selection (R & S) methods.

Kim and Nelson (2006) give four comparison problems that arise in simulation studies including comparing alternatives against a standard, selecting the best performing system, selecting the system with the highest probability of performing the best, and selecting the largest probability of success (p. 501). Their emphasis is on the constraint

applied to probability of the correct selection (PCS) (Kim & Nelson, 2006). Kim and Nelson (2006) attribute the foundation of R & S to two papers, “Bechhofer (1954) established the indifference-zone formulation, while Gupta (1956, 1965) is credited with the subset selection formulation of the problem” (p. 503). They espouse, “Both approaches were developed to compensate for the limited inference provided by hypothesis tests for the homogeneity of  $k$  population parameters (usually means)” (Kim & Nelson, 2006, p. 503).

The subset selection formulation of Gupta has a goal of obtaining a subset  $I \subseteq \{1, 2, \dots, K\}$  such that the probability of selecting the best  $I$  is  $1-\alpha$  (Kim & Nelson, 2006, p. 503).  $\alpha$  refers to the probability of not selecting the best alternative or eliminating a system when in fact it is the best.  $I$  is the retained system that is the best or if multiple systems are retained they are better than the others but are not significantly different from each other. It does this by selecting the system with the mean that is significantly better than the other output means. The disadvantage of this method is the retained set  $I$  may include several systems. The Indifference-zone formulation assists in alleviating the disadvantage of keeping multiple systems in set  $I$  by guaranteeing to select the single best system when the difference in the means of the two systems is greater than a certain level of indifference. According to Kim and Nelson (2006) “The indifference level is the smallest difference the experimenter feels is worth detecting.” (p. 504) Additionally, they refer to Hsu (1996, pp.100-102) and his conclusions that R & S links to multiple comparison procedures (MCPs) by complete multiple comparisons of the best (MCB). Kim and Nelson’s (2006) analysis concludes that “Bechhofer’s and Gupta’s procedures can be augmented with MCB confidence intervals “for free”, and Bechhofer’s procedure

is guaranteed to select a system within the  $\delta$  of the best” (Kim & Nelson, 2006, p. 508).

Note that  $\delta$  (delta) is the level of indifference decided upon by the experimenter. Refer to Kim and Nelson (2006) for discussion and detailed steps on selections techniques as well as other multiple comparison methods.

Nelson, Swann, Goldsman, and Song (2001) combine the screening procedures of subset selection and the indifference zone (IZ) by introducing a decomposition lemma. The decomposition lemma “establishes that under very general conditions we can apply an IZ selection procedure to the survivors of a screening procedure and still guarantee an overall probability of correct selection (CS) even if the selection procedure starts with the same data used for screening” (Nelson et al., 2001, pp. 952-953). The decomposition lemma allows the IZ selection procedure to be applied to the systems retained by the screening procedure in order to select the best system if the systems differ by  $\delta$  (Nelson et al, 2001, p. 953). Nelson et al. (2001) then offer combined procedures for selecting the best system and experimental results that validate its ability to find the best system with a confidence level of at least  $1-\alpha$ .

Banks et al. (2010) provide a six step procedure for Select-the-Best procedure (p. 478) to apply Nelson et al’s (2001) methodology.

1. Specify the desired probability of correct selection  $1/k < 1-\alpha < 1$ , the practically significant difference  $\epsilon > 0$ , an initial number of replications  $R_0 \geq 10$ , and the number of competing systems  $K$ . Set

$$t = t_{1-(1-\alpha/2), \frac{1}{k-1}, R_0-1} \quad (1)$$

and obtain Rinott’s constant  $h = h(R_0, K, 1-\alpha/2)$ .

2. Make  $R_0$  replications of each system and calculate the first-stage sample means and sample variances.

3. Calculate the screening thresholds 
$$W_{ij} = t \left( \frac{s_i^2 + s_j^2}{R_0} \right)^{1/2} \quad (2)$$

for all  $i \neq j$ .

b) If smaller is better, then form the survivor subset  $\mathcal{S}$  containing every system

design  $I$  such that 
$$\bar{Y}_i \leq \bar{Y}_j + \max \{0, W_{ij} - \epsilon\} \quad (3)$$

for all  $j \neq i$ .

4. If the set  $\mathcal{S}$  contains only one system, then stop and return the system as best. If

not, compute the second-stage sample sizes 
$$R_i = \max \left\{ R_0, \lceil (\bar{h}S_i / \epsilon)^2 \rceil \right\} \quad (4)$$

where  $\lceil \cdot \rceil$  means to round up.

5. Take additional replications  $R_i - R_0$  from all systems  $i$  in  $\mathcal{S}$ , or if it is more convenient obtain a total of  $R_i$  replications by starting over.

6. Compute the overall sample means for all  $i$  in  $\mathcal{S}$ . If smaller is better, select the system with the smallest mean. (Banks et al., 2010, p. 479-480)

Banks et al. (2010) provide an automated tool that implements these procedures in the SimulationTools.xls spreadsheet at [www.bcnn.net](http://www.bcnn.net) (p. 481). Banks et al. (2010) also note the research by Nelson et al (2001) and the ability of Select-the-Best Procedure to select the best system with a confidence of  $1-\alpha$  (p. 480). Understanding how simulation can be useful as well as the methods for selecting the best performing system is useful as the researcher reviews previous simulation efforts.

## **Works in Depot Maintenance, Aircraft Maintenance, and Multi-skilling Simulation**

A plethora of simulation research is readily available for review and analysis. A small segment of the research involves Department of Defense (DoD) related topics on depot maintenance activities with more existing in aircraft availability as well as cross-training and optimizing workforces. The researcher provides insights from a few of the many reviewed in these areas.

As discussed previously, Ysebaert (2011) conducted a simulation study on aircraft availability improvements associated with using and adding additional Adjusted Stock Level panels. The Adjusted Stock Level panels are extra LO panels held in supply and changed out for a damaged panel, returning the aircraft to fully mission capable status while the damaged panel is repaired (Ysebaert, 2011). Her simulation was developed in ARENA in a stepwise fashion to facilitate verification during development.

The input data used included theoretical distributions based on historical and aircraft technical data. One problematic area for Ysebaert is that the data pulled from Production System Effectiveness Data System was inaccurate for a panel repair time and frequency of repair. SMEs inputs were used in order to estimate repair times (constant) and repair frequency.

Ysebaert's (2011) results include using marginal analysis to develop a "shopping list" of panels based on the order panel selection that provided the most improvements. Using Paired-t tests she concludes that no statistically significant difference in availability exists after purchasing the first panel but practical significance exists (Ysebaert, 2011). Additionally, her "shopping list" changed when she used the availability to cost ratios. Ysebaert (2011) concluded that not every panel offers the same

return for increased availability or decreased panel hours and that there is a limit to the benefit from increasing Adjusted Stock Level Panels past five and six panels (p. 61).

Levien's (2010) research included a simulation of the KC-135 depot maintenance IDOCK process, focusing specifically on whether multi-skilling improved the BA major job. Further scoping the research, he only considered three of the six maintenance specialties used in the BA tasks (Levien, 2010). His model was built with parallel and subsequent processes at the task level detail in order to measure changes in the number of aircraft throughput, employee utilization changes, IDOCK space utilization, and each tasks waiting time (Levien, 2010).

He noted data problems similar to Ysebaert (2011) associated with the data from previously completed maintenance actions (Levien, 2010). Additionally, validation versus the real system proved quite difficult with a difference of over 22.7 days (72.5 percent) for a process that takes 31.3 days (Levien, 2010). Levien (2010) concluded that although validation proved difficult, the relative improvement in the model provides valuable insights on cross-training (multi-skilling) personnel.

Levien's (2010) results showed that major job BA would have 13.7 percent improvement in completion time by cross-training employees on 22 of the 58 tasks with lower wait time for four of the six major operations (p. 40). The results of his research can be applied to study the entire F-22 depot maintenance process to garner similar insights.

The final research discussed is Park (1991) research on cross-training in a dual resource constrained shop. The reason for discussing an older study is due to the relevancy to the multi-skilling topic in this research and Park's focus specifically on the

personnel resource without consideration for machine limits. Park's (1991) research focused on dual resource constrained systems, where both personnel and resources were needed to complete a job but excess machines exist. He used a SLAM simulation to model five work centers at varying levels of cross-trained personnel and with differing work dispatch policies (Park, 1991).

Park (1991) concludes, "The minimum introduction of worker cross-training showed the most significant improvement, and subsequent increase in cross-training had diminishing return" (p. 298). His point that training workers in at least two work centers should be the focus over training them in all work centers and that cross-training efforts may need to be focused in bottleneck work centers (Park, 1991) supports the business case analysis completed by Ogden ALC on the Multi-Trade Demonstration Project (Ogden Air Logistics Center, 2012).

The literature reviewed in this section includes a background on multi-skilling (cross-training), ways to develop and use a simulation, methods for analysis of outputs, and a review of relevant simulation studies. During the process, a gap in research presents itself in the area of workforce simulation within Air Force depot maintenance activities. The knowledge gained during this process is the starting point for this research.

### **III. Methodology**

#### **Chapter Overview**

The first portion of this chapter describes the process of the F-22 Heavy Maintenance Modification Program (depot line) and the methods used for development and validation of the discrete event simulation in ARENA 14®. The second portion of this chapter discusses the experimental methods used for comparing civilian specialties for multi-skilling.

The course of the background and methods used in my research were honed using 574th Aircraft Maintenance Squadron (AMXS), F-22 Flight subject matter expert (SME) opinions, knowledge and insights into the maintenance personnel, resources and tasks that characterize the F-22 Heavy Maintenance Modification Program.

#### **F-22 Heavy Maintenance Modification Program**

The F-22 depot maintenance operation (system) is constructed similarly to other ALC depot maintenance activities within the Air Force. The F-22 is unique in that each aircraft undergoes specified maintenance actions based on the modifications required for each production year. Additional maintenance actions completed include Time Compliance Technical Orders (TCTOs), delayed maintenance discrepancies that operational units request completed, and over and above (O&A) actions that maintenance personnel find during the depot process.

The object of primary interest (entity or flow unit) that enters and exits the system is the F-22. All discussion regarding the system boundaries, processes, maintenance actions, etc will be predicated on the understanding that an aircraft flowing through the

F-22 depot maintenance operation is the primary focus of this research. The process or system boundaries for this research need to be defined prior to delving into specific characteristics of the system.

The system boundaries are defined based on the interdependence of maintenance resources and activities towards the completion of depot maintenance on each F-22 (Banks et al., p. 12). More narrowly defined, the system is identified by the point at which inputs begin to be transformed into outputs (Anupindi, Chopra, Deshmukh D, Van Mieghem A, & Zemel, 2011). We defined inputs as any F-22 that arrives for scheduled induction into the F-22 depot line at Ogden ALC. Outputs from the system are defined as an aircraft with all scheduled and O&A maintenance actions complete that is ready for return to the owning organization. Based on these definitions of what constitutes a system or process, we define the system boundaries for this research as starting when F-22 depot personnel begin scheduled maintenance actions on an aircraft and as stopping when all maintenance actions are complete. The clearly delineated system boundaries allow for a further discussion of the flow of an aircraft through the depot process.

Understanding the flow of an aircraft within the system requires a breakdown of the process and resources within the system. Each F-22 arrives at scheduled intervals determined by engineering specifications and based on collaborative planning between the F-22 Flight and organizations that own the aircraft. Each aircraft arrives with a preplanned number of maintenance actions scheduled based on modifications required, the delayed discrepancies identified for completion and any other O&A actions found during the depot process. The aircraft is scheduled to be in the system for a predetermined number of workdays based on maintenance man-hour requirements with

all maintenance actions scheduled for completion within this time frame. The number of flow days schedule for each aircraft is broken down into seven measurable segments referred to as gates. The seven gates exist as milestones within the process to focus maintenance efforts on meeting predetermined timelines and goals for process completion. Management and production supervisors restrict personnel to working only maintenance actions required within the gate the aircraft is currently assigned and maintenance actions within the next gate do not begin until all actions from the previous gate are complete with rare exceptions. Figure 2 shows an example of the gates by day. Scheduling maintenance tasks and assigning them within each gate requires each maintenance specialty to be identified.

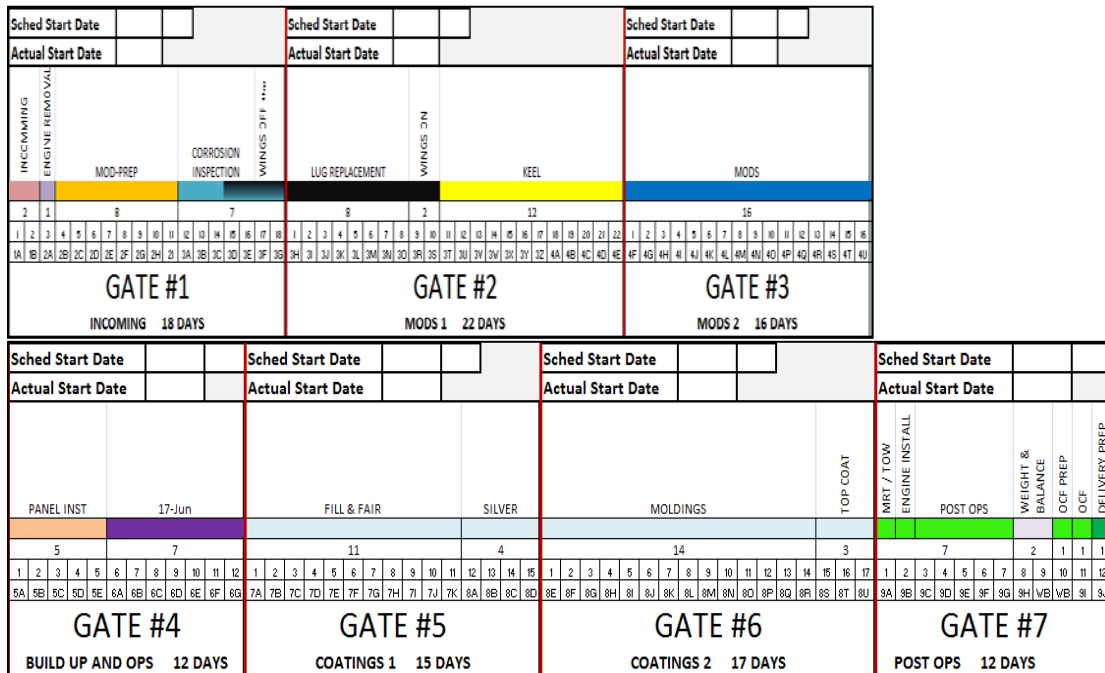


Figure 2: Gate Example

There are six Federal Wage Series (FWS) occupational specialties that complete a majority of the maintenance on the F-22 depot line. The specialties are Painter with

specialization in low observable (LO) applications, Aircraft Mechanic, Sheet Metal Mechanic, Aircraft Fuels Systems Mechanic, Aircraft Electrician, and Avionics Technicians (Ogden Air Logistics Center, 2012). A critical path analysis by the 574th Aircraft Maintenance Squadron (AMXS), F-22 Flight planners identifies maintenance activities of these six specialties as critical path tasks. The Critical Path analysis focuses my research on the specialties identified because improvements off the critical path will not improve overall system performance. F-22 Flight planners previously enlisted the help of Mariah Magagnotti and Joseph Hasler (both PhD students at Clemson University), and Dr Scott J. Mason from Clemson University to produce an automated scheduling tool to identify man-hour requirements per specialty per day. Figure 52: Clemson Scheduling Tool (MORS) Example, in Appendix A, shows an example of several days of the man-hour requirements from the tool. Analysis of this tool using actual man-hours consumed on multiple aircraft shows that the six specialties identified previously account for 97 percent of the total man-hours required to complete maintenance actions on an aircraft. SME input and analysis of the Clemson tool confirms this research focus on the Painter (LO or AP), Aircraft Mechanic (AG), Sheet Metal Mechanic (AS), Aircraft Fuels Systems Mechanic (AT), Aircraft Electrician (AR), and Aircraft Avionics (AV) FWS occupational specialties.

The final portions of the system that must be identified prior to model development are the resources required for maintenance activities. The resources include maintenance personnel by specialty, general maintenance docks, and LO docks. The six FWS occupational specialties will be the primary resource of focus for this research. Maintenance personnel and associated activities operate 24 hours a day, Monday to

Friday with every other Friday off and differing numbers of personnel per specialty scheduled for each shift. The naming convention of the docks explains the type of maintenance that is completed in each one. The one caveat is that general maintenance activities can be completed in maintenance, or LO docks but LO maintenance is only completed in LO docks. Additional resources are required during the depot process but SME input narrowed the constraining resources (outside of personnel) down to these two for modeling purposes.

F-22 Depot Operations' workload will be changing significantly over the next year. Currently the number of aircraft within F-22 depot maintenance operations at Ogden ALC is restricted to a specific number at any one time. The depot maintenance work is currently split between Ogden ALC and the Lockheed facility in Palmdale, CA but the Air Force recently announced the consolidation of all F-22 depot maintenance activities to Ogden ALC (United States Air Force, 2013). The new workload will double the number of aircraft in the system with a corresponding increase in annual throughput. Doubling the workload and associated resources of the depot operation combined with the current overtime and utilization problems previously discussed makes simulation research on multi-skilling extremely timely and relevant for decision makers.

## **Model Development**

Model conceptualization starts by identifying the goal of the model. Stephen Covey's Second Habit in *The 7 Habits of Highly Effective People* is to "Begin with the End in Mind" (2004). We start model conceptualization by reverting to the initial research questions to clearly understand the goal of this research.

**Research Question 1:** Which maintenance specialties within F-22 Depot Operations should be considered for multi-skilling into the low observable (LO) specialty?

**Research Question 2:** How does multi-skilling affect aircraft throughput and employee utilization in F-22 Depot Operations?

**Research Question 3:** To what extent does multi-skilling offset overtime use to meet aircraft flow day requirements and throughput targets?

The goal of our model is to give a quantitative basis for multi-skilling as well to gain insight into specialty selection for multi-skilling. The basis required for our decision analysis is whether or not there is an increase in aircraft throughput with an associated decrease in time an aircraft spends in the system and whether or not improvements in employee utilization are realized from multi-skilling. With these goals in mind, the model needs to be able to capture the following outputs:

- Throughput
- Average flow days
- Average flow days by type of aircraft (based on hours)
- Time in each gate
- Employee man-hour use by specialty
- Employee use in secondary skill (multi-skill use)

- Employee percentage use in secondary skill
- Overtime
- Dock usage
- Dock queue time

The desired outputs are key considerations in model development to ensure the final results and associated recommendations have decisional implications. The next step is to develop a conceptual model using the process insights of the F-22 Heavy Maintenance Modification Program and desired outputs of the simulation.

### **Scope Decision**

The decision on the scope of the simulation and the level of detail needed for decision making must be addressed prior to model conceptualization. According to Sadowski and Grabau, it is easy to fall into the trap of “Getting Lost in Detail” (2004). The decision on the level of detail required in order to perform substantive analysis of the system is critical in this study.

The initial direction of the modeling effort is to scope the model to a manageable level of detail by identifying the segments of the real system to be included. The first course considered is to model a few of the seven gates within the system in order to alleviate undue levels of detail associated with the size and complexity of the system. Modeling two or three gates will give an idea of output behaviors associated with those gates as multi-skilling is implemented and may give an accurate representation of the overall system behaviors associated with multi-skilling.

However, the problem with including only certain gates is that man-hour requirements per specialty vary greatly between each gate and isolating the model to certain gates may inaccurately show higher manpower availability than actually exists within the entire system if the wrong gates are included. The impact of the inaccurate resource availability will show more or less benefit from multi-skilling than really exists, depending on the resources that display the inaccurate availability and the degree to which the availability is over or understated. Further complicating the problem of identifying gates for inclusion is that SME inputs identify periods when excess resource (personnel) capacity exists due to inactivity in a gate (i.e. no aircraft in the gate). Management and planners are unable to forecast the gates and periods when this excess capacity will arise, leading to a shift to model all seven gates versus scoping the model to a few. Insights gained from reviewing multi-skilling research by Major Andrew Levien further supports the shift to developing a model that captures the entire system.

Levien's multi-skilling simulation study on the KC-135 depot process considers one small segment of the overall process and is a good first step into multi-skilling simulation research within the ALC's (2010). However, his research does not provide insights from a system perspective that can be used for managerial decisions on multi-skilling because interactions of maintenance tasks and personnel within depot processes are complex and isolated process improvements (local optimization) may not impact overall system performance. On the other hand, improvements in employee utilization in certain areas may have an unforeseen impact on another process within the system, influencing overall system performance measures. The model needs to include all gates in order to ensure potential impacts are not hidden due narrowing the scope of the model.

Additionally, the goal of this research is to provide adequate decision level insights into the impact multi-skilling will have on F-22 Heavy Maintenance Modification Program performance measures and modeling the entire system is the only way to ensure those insights are captured. After deciding to model the entire system, the next step is to decide on the level of detail to include within the model.

The optimal level of detail is to model the system at task level in order to most accurately capture the benefits of multi-skilling. Task level detail allows for movement of personnel between tasks at shorter periods, permitting the model to measure the use of multi-skilled personnel and benefits in greater detail than an aggregate level. However, the time constraints of the study, the sheer number of maintenance tasks (three to four thousand) required on each aircraft, and the variability of the number of tasks from one aircraft to the next makes modeling all tasks impractical for this study. Data accuracy concerns also exist at the task level.

The data for task level analysis is found not to be accurate after considering SME inputs and current work practices. Maintenance technicians complete tasks in a given area on the aircraft that may overlap multiple work cards. Many times the man-hours used to complete the preparation task are only reflected in the data for one of the many tasks that required the prep work. For example, sanding a structural area of the aircraft may be required if you remove one panel or all four in the area but the man-hours are usually captured in only one of the task times. If you simulate at the task level the data will reflect longer times for certain tasks and shorter times for others with no consistency to which one the sanding hours are applied. The data discrepancy would not be a problem if all the panels were removed every time but each aircraft is different and

requires differing levels of maintenance. An additional consideration is how the inconsistency of the man-hour allocations will affect input distributions for the task times. The data discrepancies described and time limitations of the study steer the research towards a more aggregate level simulation of the system.

Deciding on the level of aggregation is complicated given the amount of data available and number of tasks associated with each aircraft. Since variability of man-hour requirements is the most significant challenge that multi-skilling is proposed to address, the key factor in determining the level of aggregation for the model is the ability to simulate multiple types of aircraft from a man-hour requirement perspective.

Two questions are considered in the aggregation decision. 1) What data is currently available and 2) What type of data do managers and planners use for their scheduling/forecasting? Searching to answer the first question revealed that data is available from the task level up to the total man-hours required per aircraft along with many derivatives of the data in between the two levels. Availability of data is not the problem and understanding the types of data gives a clear picture of the numerous modeling options but does not assist in choosing the level of aggregation for the simulation.

The answer to the second question leads to the realization that the F-22 planners currently use aggregate data output from the Clemson tool to forecast manpower needs, aircraft flow through the system, and to produce a visual layout of all aircraft schedules by flow day. The Clemson tool produces the aggregate man-hour requirements per specialty per flow day for an aircraft. The tool pulls from Programmed Depot Maintenance Scheduling System (PDMSS) outputs the standard hours required based on

the projected maintenance requirements of an aircraft or pulls in the actual hours used to complete an aircraft. Most decisions within the F-22 Heavy Maintenance Modification Program are viewed from the man-hour requirement perspective and the simulation model should incorporate that paradigm.

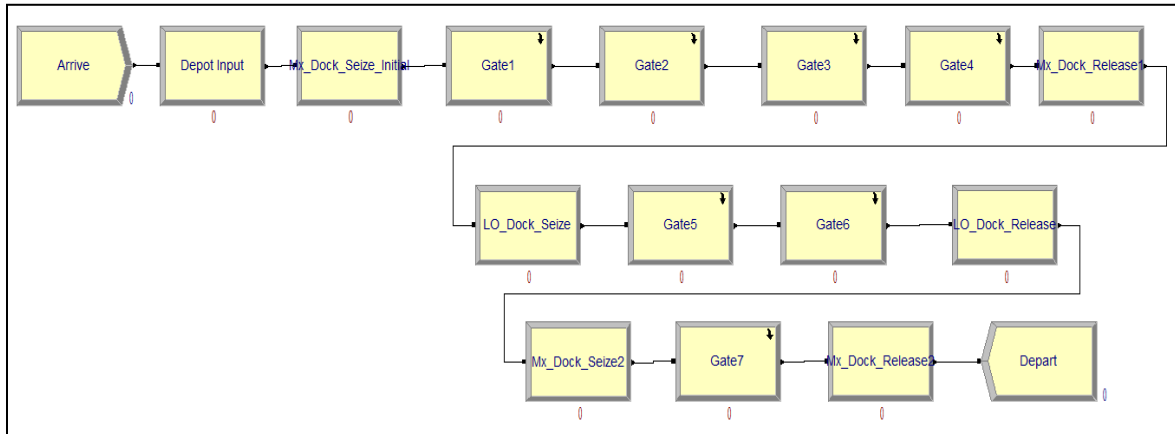
Using data that managers and their team members are familiar with facilitates getting their buy-in as the model is developed and also allows for more accurate feedback from SMEs on the details of the system during model development. Additionally, using the aggregate data mitigates some of the task level data anomalies because the tasks are combined and include all tasks performed by that specialty on a specified day. For these reasons, the plan is to build the model with the intent of simulating the flow of an aircraft through the system with maintenance actions on each aircraft being performed based on man-hour requirements per specialty per day. The next step following the decision on the scope of the model and the level of detail is to begin conceptualization of the model.

### **Conceptualization**

The first portion of conceptual development of the model is to layout the flow of the F-22 Heavy Maintenance Modification Program. SMEs are consulted frequently during each stage of development in order to accurately capture details of the system and get their buy-in on the final model. The basic flow and critical points are drawn in ARENA 14® to facilitate ease of modification while going over the process with SMEs at Ogden ALC.

Figure 3 depicts the conceptual flow of each F-22 through the system. An aircraft arrives for input into the system and all maintenance work packages are loaded into PDMSS prior to starting maintenance on the aircraft. In the arrival process for the

conceptual model the decision is made on the type of aircraft that has arrived (based on man-hour requirements) and then maintenance actions are scheduled by gate.



**Figure 3: Basic Process Flow**

Following arrival and the input decision, the aircraft is towed to a general maintenance dock for scheduled maintenance for Gates 1 through 4. The aircraft enters Gate 1 on the schedule and the focus of all maintenance efforts are on completing the maintenance actions assigned to Gate 1. Upon completion of Gate 1 the aircraft enters into Gate 2 on the schedule and all maintenance requirements for Gate 2 are completed. The same steps are completed through Gate 4. The aircraft is moved into a fuel dock at the end of Gate 4 for a short period. SME inputs and the short duration of fuel dock usage led to excluding the fuel dock from consideration because it is not considered a critical factor for inclusion and does not represent a present or future constraint.

Once Gate 4 is complete, the aircraft is moved from the general maintenance dock to the LO dock for Gates 5 and 6. Gates 5 and 6 are completed in the same way as the previous four gates with all maintenance actions being completed prior to moving into

the subsequent gate. Upon completion of Gate 6 the aircraft is moved from an LO dock back to a general maintenance dock for completion of Gate 7's maintenance requirements. All maintenance requirements for the aircraft are completed before exiting Gate 7. Following completion of all maintenance requirements the aircraft exits the system and returns to the owning organization. After conceptual flow mapping, the detailed simulation model requires identifying the assumptions that are made prior to beginning development.

### **Model Assumptions, Constraints, and Limitations**

A simulation model is an abstraction of reality and therefore assumptions need to be made because the complexity of the F-22 Heavy Maintenance Modification Program makes it unfeasible to include every aspect of reality in the simulation. The assumptions made in order to simplify the system and constraints implemented create limitations with the model and associated output data. Before going in detail on the steps to build the model the assumptions, limitations, and constraints need to be clearly stated.

*Assumption 1:* SME knowledge is considered legitimate and the insights and feedback on system operations is considered to be accurate.

*Assumption 2:* All adjusted data from the Clemson Tool is representative of the real inputs.

*Assumption 3:* Every employee in an occupational series is homogenous. In reality employees may have varying levels of experience but for the model all employees in a given specialty complete maintenance actions at the same rate and quality. Proficiency impacts are reviewed during the analysis portion of the research.

*Assumption 4:* The maintenance man-hour requirements for each occupational series required in a given flow day are independent of subsequent flow days requirements.

*Assumption 5:* Leadership and production supervisors focus maintenance efforts based on first in first out prioritization and ensure all maintenance actions within a gate are complete prior to moving to the next gate.

*Assumption 6:* F-22 Heavy Maintenance Modification Program planners and operational wings deconflict arrivals to constrain the system to a specific number of aircraft or WIP.

*Assumption 7:* The number and type of personnel seized to meet man-hour requirements for a given flow day are not released until the requirement is met. Using the aggregate man-hour requirements vs. tasks eliminates the possibility of personnel being reallocated to a higher priority task or finishing shorter tasks and moving to another aircraft.

*Assumption 8:* The four aircraft selected for simulation have man-hour requirements that are representative of the fleet.

*Assumption 9:* The annual throughput is based on 225 workdays per year and model output will be based on flow days.

*Limitation 1:* Model does not consider external factors including availability of parts and specialties outside of the six FWS occupations identified on the critical path.

*Limitation 2:* The aggregate level of data used may lessen impacts of multi-skilling due to inflexibility of personnel to move from task to task.

*Limitation 3:* The balanced shift modeling approach limits direct comparison versus current scheduling policies. For this research, the balanced shift approach is defined as having an equal number of personnel on each shift for each specialty.

*Limitation 4:* Assumption 7 causes model to hold multi-skilled resources even when the primary resource becomes available. This causes an overestimation of multi-skilling resources needed to gain a certain level of benefits. In reality, managers could reallocate personnel at shift change or during the process to balance the current workload.

*Constraint 1:* Initial work in process (WIP) set to the current state value for aircraft WIP, doubling aircraft WIP in future state.

*Constraint 2:* Maintenance technicians can work up to 2 days ahead of technicians in differing specialties working the same aircraft.

*Constraint 3:* The maximum number of personnel in a specialty seized for work on one individual aircraft is constrained to SME defined values.

*Constraint 4:* The maintenance process will attempt to seize enough personnel to complete man-hour requirements for a specialty in 1 shift, not to exceed Constraint 3. This eliminates seizing 16 personnel to complete 16 hour requirement in 1 hour (Ex. 10 hour requirement = 2 personnel to complete in 1 shift; 25 hour requirement = 5 personnel to complete in 1 shift).

*Constraint 5:* Gate 4 will take no less than 12 days to complete. This constraint reflects work completed by specialties outside of the six specialties of interest. Per SME feedback, the man-hour requirements do not reflect the flow days it takes to complete an aircraft and 12 days is the minimum time to complete the gate.

*Constraint 6:* Gate 5 will take no less than 10 days to complete. This constraint represents the minimum time that an aircraft takes to complete these gates based on cure time associated with LO maintenance.

*Constraint 7:* Gate 6 will take no less than 8 days to complete. This constraint represents the minimum time that an aircraft takes to complete these gates based on cure time associated with LO maintenance.

### **Model Description**

ARENA 14® is the software chosen for use in this research. It is a commercial simulation software in which the Air Force has several licenses and currently uses in a variety of decisional and educational capacities. The software requires minimal coding and includes built in capabilities that facilitate timely development of complex simulation models. The simulation model developed in ARENA 14® is based on the conceptual

model previously described in Figure 3. The following sections briefly describe the model developed. See Appendix A for the full model description and development.

The F-22 (entity of interest) flows through eight main sub models including Characteristics and a separate sub model for each of the Gates 1 through 7 as depicted in Figure 4: Top Level Model. For the current state baseline model the aircraft arrives every 19 days based on the real system target annual throughput with 225 workdays per year. Once the aircraft is processed in all eight main sub models it exits the system and is disposed of in the Depart process. The variable views showing zeros track the variables indicated by the title above each one as the model runs.

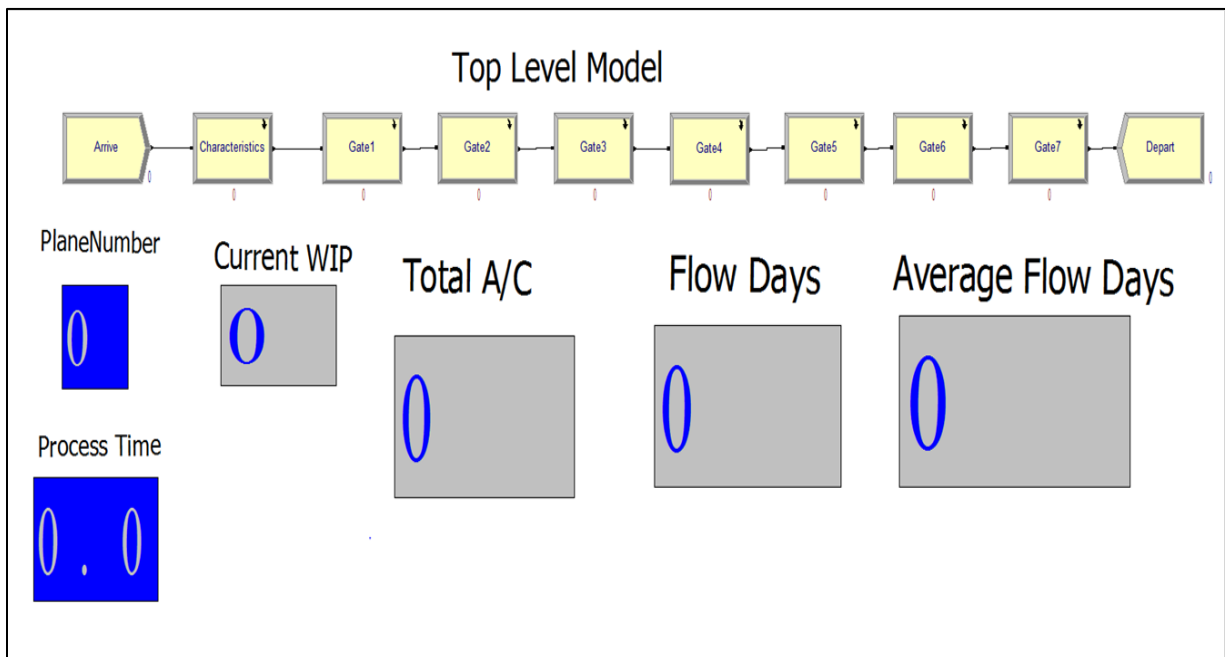
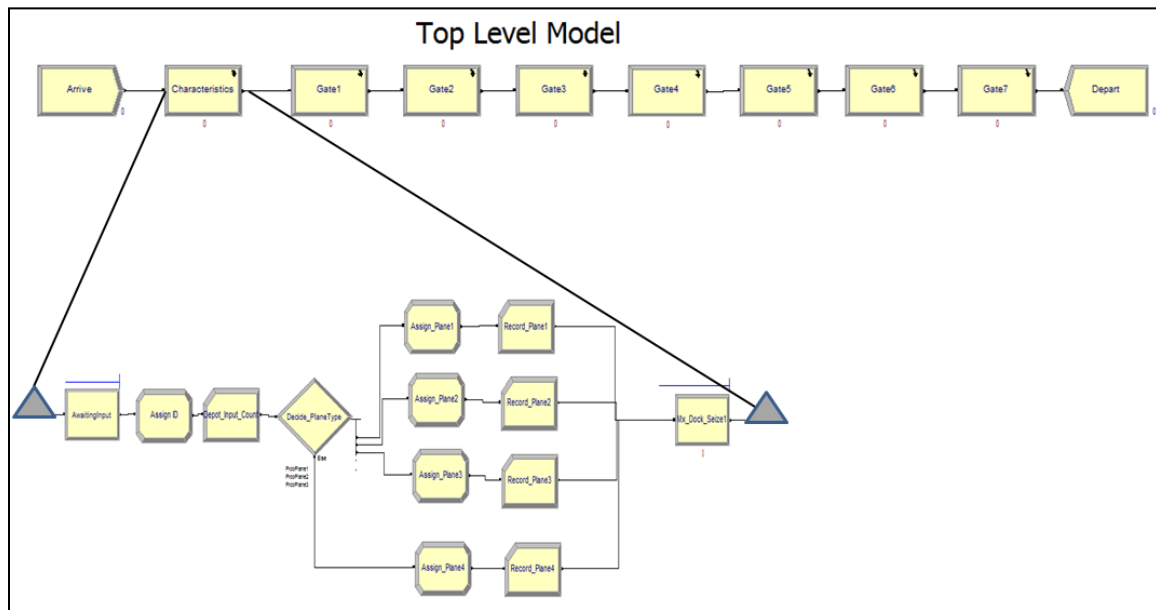


Figure 4: Top Level Model

## Characteristics Sub Model

After entity creation the aircraft flows into the Characteristics sub model as seen in Figure 5 for decisions on the type of aircraft arriving and to “deconflict” arrivals based on the constraint to have only a certain number of aircraft within the system at any time.



**Figure 5: Characteristics Sub Model**

Upon entering the Characteristics sub model seen in Figure 5, the aircraft flows through the AwaitingInput module and is held until the number of work-in-process (WIP) aircraft in the system is less than the maximum WIP constraint using Equation 5. The WIP\_Constraint variable is used as the maximum WIP constraint and the value is initially set to reflect the current constraint of the real system.

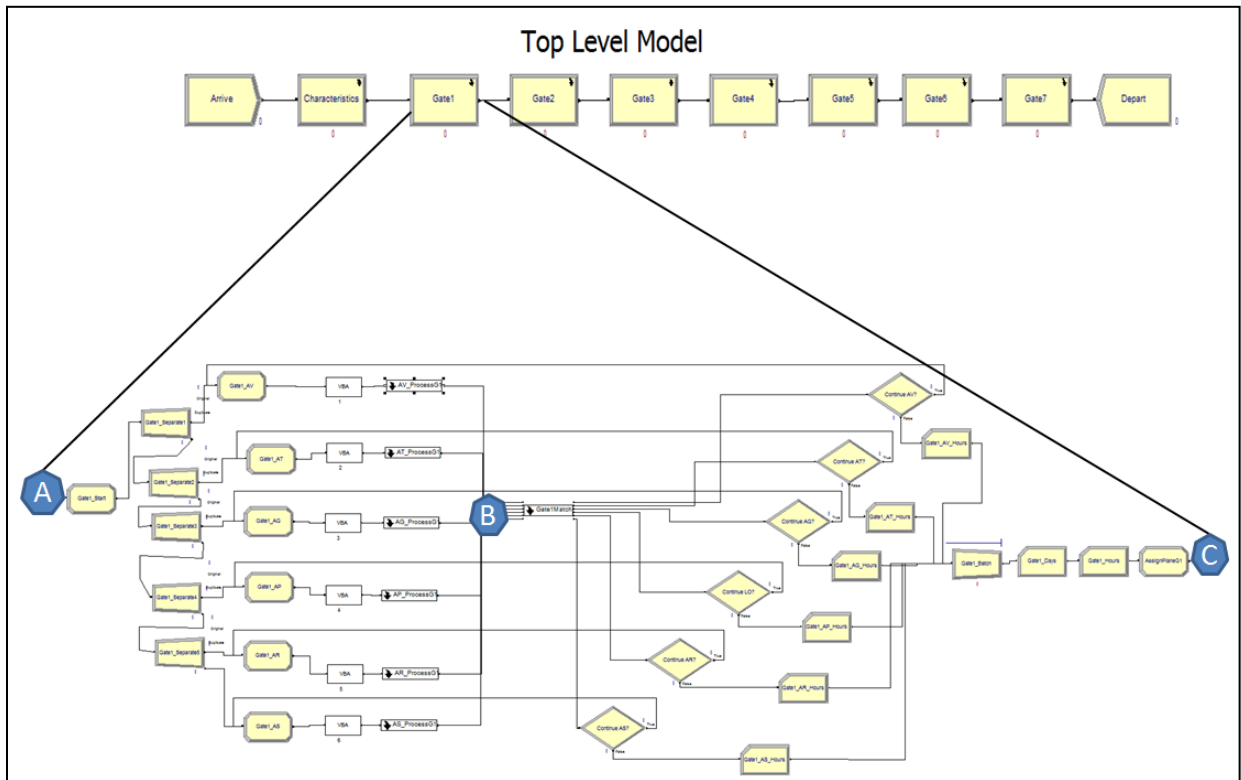
$$(Gate1.WIP + Gate2.WIP + Gate3.WIP + Gate4.WIP + Gate5.WIP + Gate6.WIP + Gate7.WIP) < WIP\_Constraint \quad (5)$$

The aircraft then flows into the Assign ID process and is assigned a unique identification (ID) number, a unique ID variable, and a plane picture for animation

purposes. Next, the aircraft is counted as a depot input and the decision is made on the type of plane arriving based on random chance with a certain probability of the four different types of arrivals being selected. The decide module uses ARENA's standard random number generation stream and is the only stochastic input in the model. The random selection of the four types of aircraft induces man-hour requirement variability into the system and is a critical factor to accurately reflect the variability of real system inputs. The four plane types are used in Gates 1 through 7 sub models to assign man-hour requirements for maintenance processing times. The decision on the number of plane types and selection of hourly requirements is discussed later in the Inputs portion of this chapter. Following the decision on plane type, the aircraft exits the Characteristics sub model for Gate 1 and is defined as work-in-process (WIP).

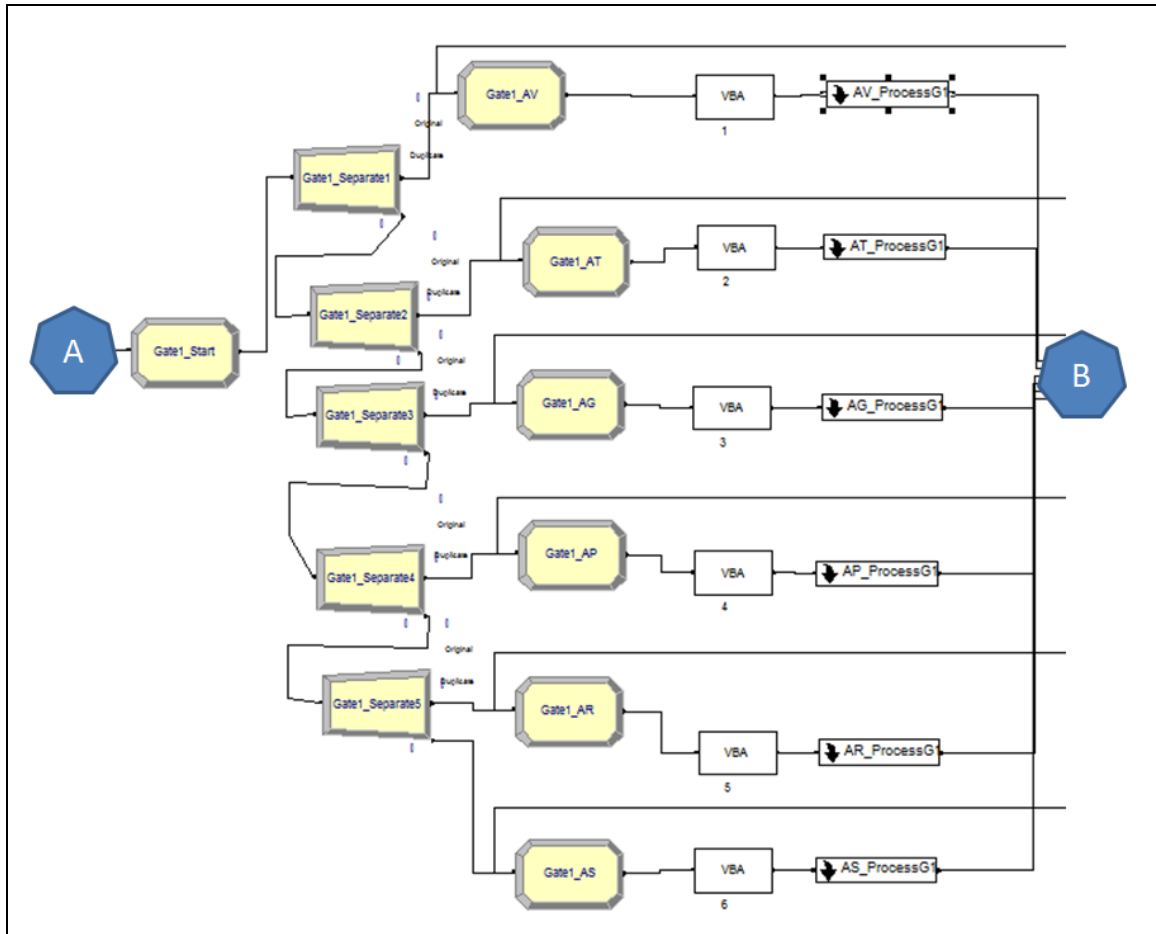
### **Gate 1 Sub Model**

Transformations from inputs into outputs through the completion of maintenance hour requirements begin in Gate 1. The previous sub model is used to determine the plane type or PlaneNum attribute based on the four possible plane types and then constrains the system to a defined WIP value. Gate 1 uses the attributes defined in the Characteristics sub model for decisions on processing times per specialty as the aircraft moves from one day to the next. The Gate 1 sub model is broken down into six main processes, two main sub models with several record functions used to tally statistics throughout the gate. Appendix A shows the full layout of Gate 1 with in-depth discussions on the modules and functions. The following sections discuss the Gate 1 Sub Model in two sections, shown in Figure 6.



**Figure 6: Gate 1 Sub Model**

The first half of the Gate 1 discussion centers on the modules between points A and B in Figure 6. The second half will center on the processes between points B and C. The researcher begins the discussion with the first processes and the ProcessG1 sub model in Gate 1, depicted in Figure 7: Gate 1 Sub Model (a).



**Figure 7: Gate 1 Sub Model (a)**

The first process upon entering Gate 1, Gate1\_Start, assigns the gate start time as the aircraft enters the gate. Next, the aircraft is separated into six different entities using five separate blocks and then flows into separate paths representing the six FWS specialties of interest.

In queuing theory terms, each path represents a different type of server required to complete a specific type of maintenance. The system has six types of servers (FWS maintenance specialties) that can do maintenance and using a different path design allows resource pooling based on the type of server. When multi-skilling is introduced the server is able to complete maintenance hours associated with multiple resource pools

versus just one. The paths are replicas of each other with minor equation differences. Only the AV (avionics) path is discussed in detail to avoid duplication and the differences of the paths are subsequently detailed in the full model description in Appendix A. For consistency purposes, the separated aircraft is referred to as entities and again described as an aircraft when they are joined back together.

The separated entity flows into an assign module, Gate1\_AV in which a global variable (AV\_Available) and attribute (Counter) are assigned. The Counter attribute is given a value +1 and adds one to the count every time the entity flows through the assign module. The AV\_Available variable assigns the current value based on the number of avionics technicians available in the set of resources called AVIONICS using Equation 6.

$$AV\_Available = NumberAvailable - NumberBusy \quad (6)$$

The AVIONICS set includes the avionics personnel (AV resource) and a separate multi-skill resource for each of the five other specialties paired with AV (AP\_AV, AS\_AV, etc). The benefits of using a set are that sets allow multiple resource types to be seized to complete processing (maintenance requirements). This is important with the introduction of a multi-skilled workforce because it allows multiple resource pools to complete maintenance man-hour requirements.

### **VBA Block**

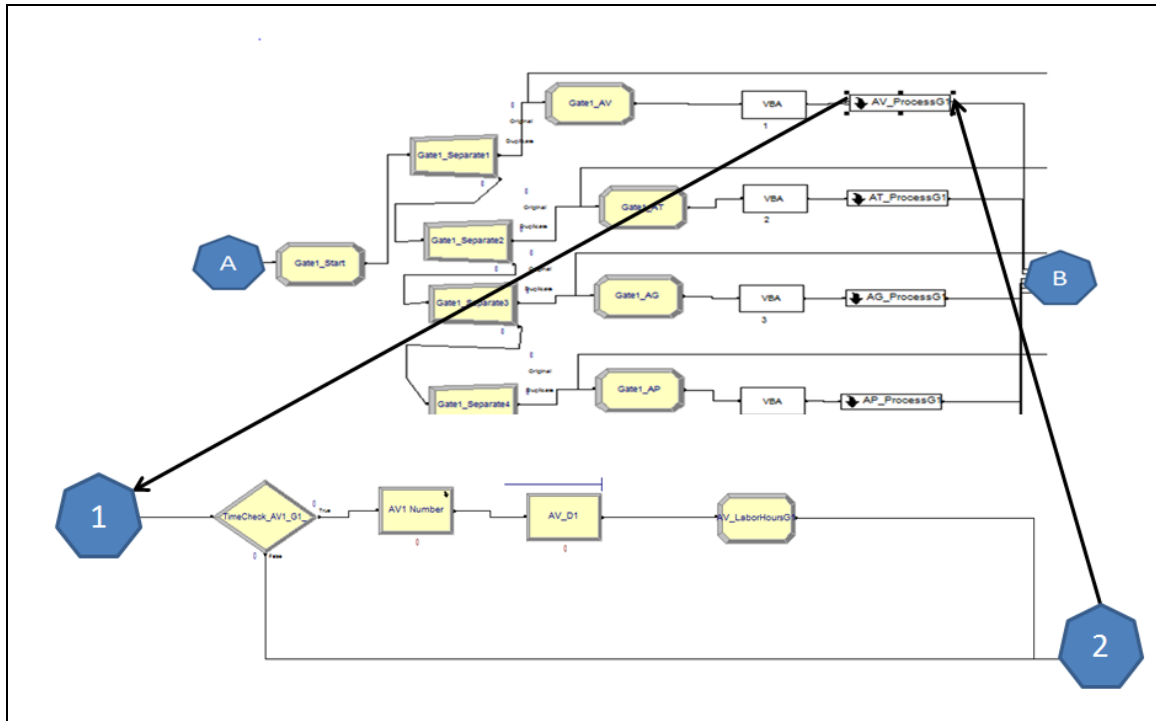
Following the assign module the entity advances to a visual basic application (VBA) block. The block runs custom VBA code that first finds the path for an excel document (Model Input Data.xls) containing man-hour requirements by specialty and

flow day for the aircraft inputs selected. The document needs to be open prior to running the model to minimize run time associated with continually opening the document.

Next, the VBA code looks to the tab for one of the aircraft inputs based on the PlanNum attribute. Then it starts at the first day of requirements for the given specialty path the aircraft is in and assigns the man-hour requirement value to the ProcessTime attribute. Concurrently the code references a different row and cell for the following flow day to identify the start of the next gate. If the next day is the start of the next gate the VBA code assigns a ContinueFlag attribute value of zero to reflect the last day of the gate. Once the ProcessTime and ContinueFlag values are assigned, the aircraft proceeds to a sub model called AV\_ProcessG1.

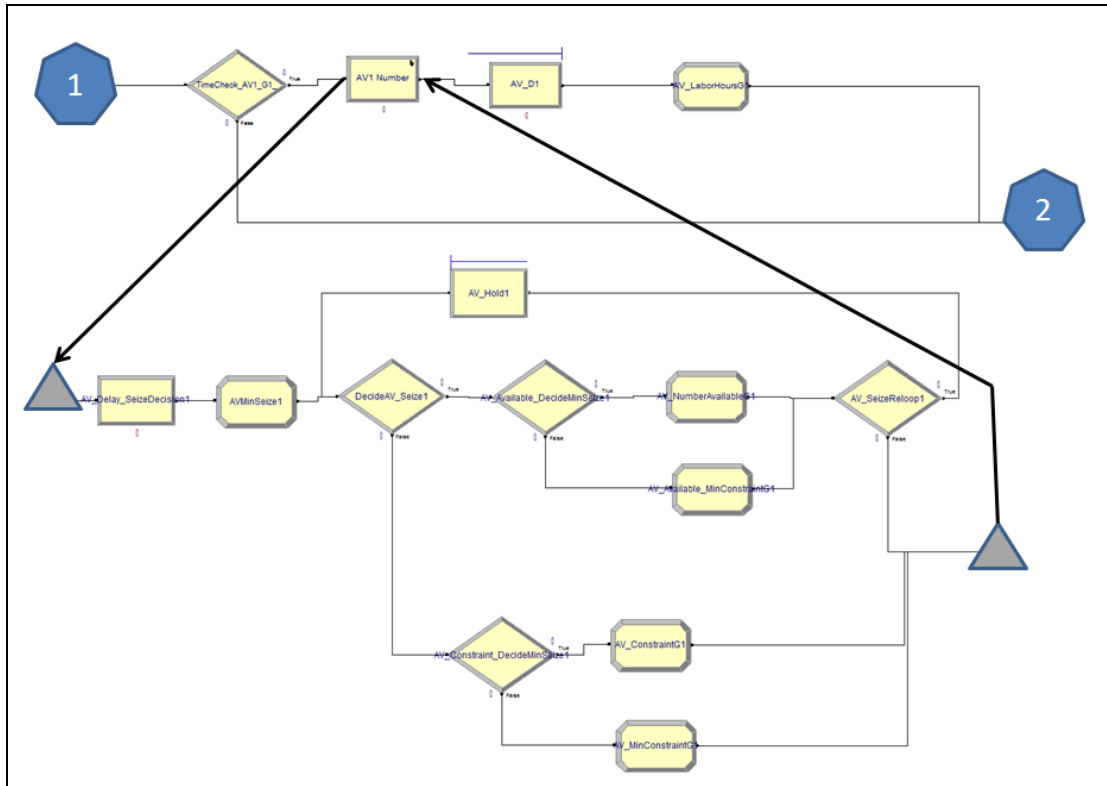
#### **AV\_ProcessG1 Sub Model**

The AV\_ProcessG1 sub model performs two main functions 1) it decides on the number of maintenance personnel to seize in order to fulfill daily man-hour requirements for the aircraft and 2) it seizes the aircraft and personnel resources for the required numbers of hour to meet the days maintenance requirements. The path through the four processes in the sub model is depicted Figure 8: AV\_ProcessG1 (Gate 1 Sub Model between points 1 and 2.



**Figure 8: AV\_ProcessG1 (Gate 1 Sub Model)**

The first step is deciding on whether the aircraft has maintenance requirements for the current flow day. The TimeCheck\_AV1\_G1 process decides if maintenance requirements exist on the aircraft for the day. If the ProcessTime attribute is greater than zero then the aircraft flows on to AV1 Number process, otherwise it bypasses the other processes and exits the sub model. The bypass is important because the aircraft could be held in the queue to be processed in subsequent blocks even though it had no requirements for the day. Once the decision is made to continue or bypass, the entities requiring maintenance flow into the AV1 Number sub model shown in Figure 9 for resource allocation decisions.



**Figure 9: AV1 Number (AV\_ProcessG1 Sub Model)**

The basic function of AV1 Number sub model is to assign the number of personnel to be seized to meet man-hour requirements for the day based on the number of personnel available. If none are available it holds the aircraft in the sub model until personnel become available. Before any decisions are made the aircraft is delayed for one minute in the AV\_Delay\_SeizeDecision1 sub model so previously held aircraft can exit the sub model when personnel become available. The delay is important because it allows aircraft held in the sub model to clear once personnel become available prior to the next aircraft initiating resource allocation decisions, preserving the first-in-first-out priority processing of the model. The aircraft then flows through several decision points in order to avoid allocating more personnel than SMEs defined as the maximum number of personnel that would be assigned.

Additionally, it constrains the number of personnel assigned to complete maintenance actions to no more than are required to complete the maintenance hours required in one shift. Further defined, the constraint assigns a value for the maximum number of personnel required to complete the flow day man-hour requirements without falling below the minimum time the aircraft should be in work each flow day as identified by SMEs. Following the decision on the number of personnel needed to complete the maintenance requirements, the entity flows to the AV\_D1Process.

### **AV\_D1 Process**

The AV\_D1 process is the heart of this simulation research. The aircraft flows into the process and is delayed while maintenance man-hour requirements are met for the day. This process and its sister processes in the other specialty paths are the only process modules that convert inputs into outputs within the system. The input is considered an aircraft with maintenance requirements and an output is considered an aircraft with all maintenance man-hour requirements met. All other processes up to this point are used to assign attributes and variables to facilitate this process.

The process uses a standard type of module with a Seize Delay Release action and assigns resources by Set. The set name is AVIONICS\_AV and includes the AV resource and the five additional multi-skill resources. The quantity used is the AV SeizeNum attribute assigned in the AV1 Number sub model, discussed fully in Appendix A. The selection rule is Preferred Order and the order is set for all runs subsequent to the baseline run with the priority of first seizing resources that have lower utilization rates in the

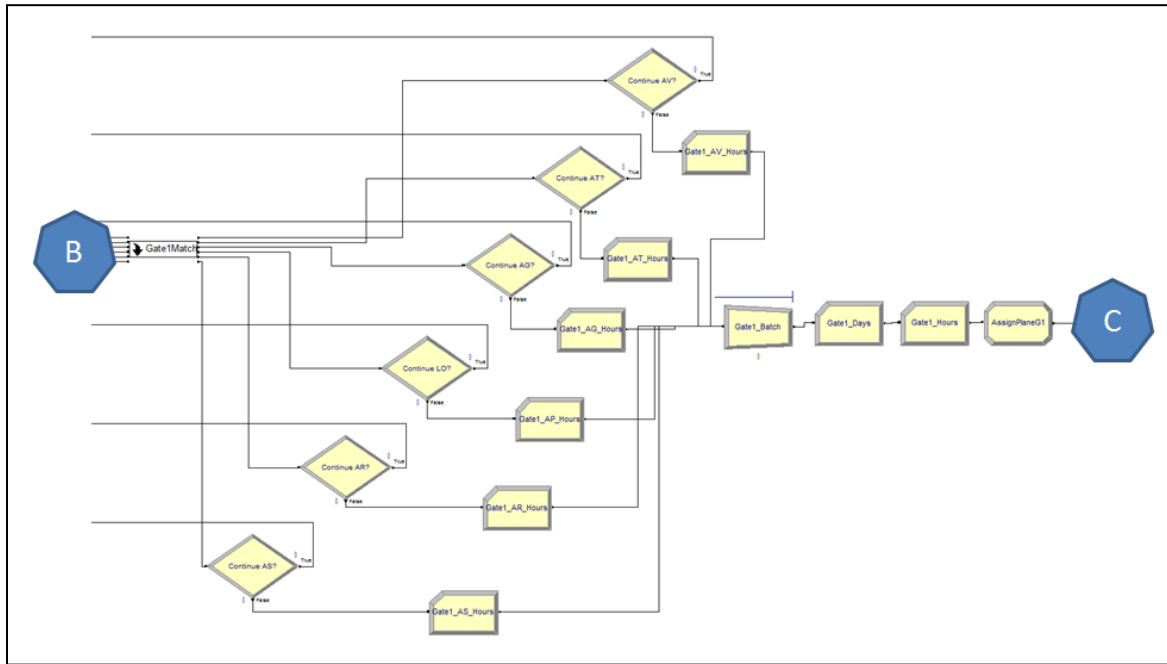
baseline outputs. Identifying the quantity of resources (personnel) seized is a critical step before moving on to the calculation of the processing (delay) time value.

The amount of time the aircraft is delayed (processing time) is based the man-hours required for AV on the current flow day (ProcessTime), the number of personnel assigned to complete maintenance (AV SeizeNum), and an efficiency factor for the pool of resources used (EfficiencyFactorAV). Equation 7 depicts the function used to decide the value of the process delay.

$$\text{ProcessTime} / (\text{EfficiencyFactorAV} * \text{AV SeizeNum}) \quad (7)$$

The efficiency factor is used to adjust the efficiency of the resource pool with multi-skilling. The initial value of the resource pool is one and can be adjusted down (.99, .98, etc.) to depict a loss in skill or efficiency. Levien (2010) multiplies processing times by a cross training factor in his multi-skill research on the KC-135 PDM process in order to emulate longer task durations associated with multi-skilled employees completing maintenance tasks. The efficiency factor in this research mathematically produces similar results by increasing task times as efficiency (task proficiency) decreases. However, multi-skilling an employee stipulates that the employee is fully qualified at the journeyman level on both skill sets (Federal Service Impasses Panel, 1997) and therefore equally proficient. The baseline model and experimental runs are initially run with an efficiency factor of one. The analysis section of this chapter explains the sensitivity analysis methods used to gauge the impacts on model outputs of decreasing skill within the labor pool. Once the maintenance man-hours are met for the current flow day the aircraft is released and proceeds through modules that record several variable values, then the entity exits the AV\_DIProcess.

The next few paragraphs discuss the second half of the Gate 1 sub model, covering the last sub model and process modules in Gate 1 (depicted in Figure 10).



**Figure 10: Gate 1 Sub Model (b)**

In synopsis, the second half of the gate restrains or aligns the six identical entities in order to stay within a certain number of flow days of each other. It then re-loops the entities back to the beginning of the gate when the entity requires more flow days within the gate and combines the entities back into one aircraft before allowing it to exit the current gate. The mechanism aligning flow days by identical entities is the first process in the second half of the gate and occurs within the sub model Gate1Match.

### **Gate1Match**

The first process in the second half of the gate is the Gate1Match sub model described fully in Appendix A. This process is important because it restricts the six duplicates of one aircraft to within a certain number of flow days of each other based on

SME consultations. The LoopConstraint is the variable created and used to reflect the SME defined constraint for how far ahead maintenance specialties can work from other specialties working the same aircraft. Functionally, this process realigns all six specialties' entities to the same flow day and does so every so many flow days as defined by the LoopConstraint. Once the flow days are realigned the entity flows out of the sub model to another decide module in Gate 1.

### ContinueAV? Module

The next decide module *Continue AV?* decides whether or not the entity has more flow day requirements in the current gate. The parameters displayed in Figure 11 re-loop the entity back to Gate1\_AV module if the ContinueFlag attribute is one. The aircraft then recompletes the Gate 1 AV path. Recall that the VBA block assigns a value of zero to the ContinueFlag if the next flow day is the start of the next gate. When the value is zero and the entity enters the Continue AV? module, the condition is false and the entity is directed to the exit path of the Gate 1 sub model.

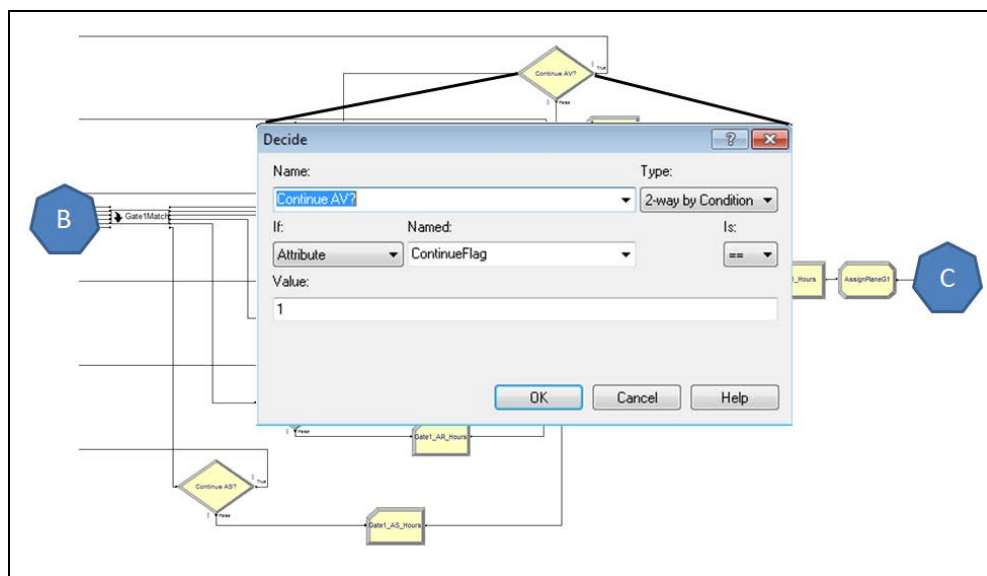


Figure 11: Continue AV?

## Gate 1 Exit Path

The exit path of each gate routes through five modules before exiting Gate 1. The modules include a batching module, three record modules, and an assign module as shown in Figure 12.

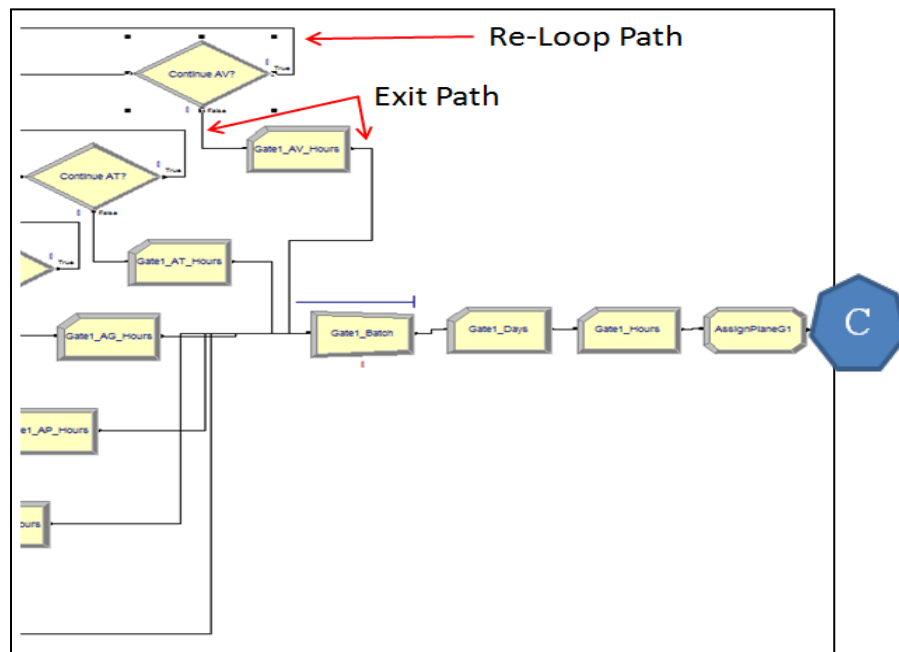


Figure 12: Gate 1 AV Re-Loop and Exit Path

The important characteristic of the exit path is that entity flows to the Gate1\_Batch module and is held until the other five entities with the same IDNumber arrive. Then entities are combined back into one aircraft and it is released to the final two record modules and an assign module. Gates 1 through 7 are almost identical with only minor differences in regards to hold functions, record modules, and dock seize modules. For in-depth description of each difference, refer to the full model description in Appendix A.

The model of an aircraft flowing through the F-22 Heavy Maintenance Modification Program is discussed in the previous sections with a focus on the process of

transforming an input aircraft into an output aircraft with all maintenance requirements completed. In order for the model to transform an input aircraft into outputs, the inputs for the model must be identified.

## **Inputs**

### **Resources**

The resource inputs into the model include personnel from the six FWS specialties of interest, general maintenance docks, and low observable (LO) maintenance docks. The general maintenance and LO docks are set at the current, then future state levels based on the current and projected number available. The personnel inputs require further discussion on their inputs.

Currently, the F-22 Heavy Maintenance Modification Program operates on a three-shift schedule with only LO personnel on mid shift. During this research, a limitation was identified with the scheduling function in ARENA 14®, hindering the ability to simulate differing resource levels across the three shifts. The scheduling function's preempt rule only preempts one entity's resources when multiple entities are being processed within a model. The schedule can change to reflect no resources available but ARENA 14® allows the model to continue to process the entity, even with no resources available. This causes the model to allow for more labor hours than should be available and distorts the scheduled resource utilization statistics.

However, the current proposal is for balanced shifts with the addition of the future workload. Balanced shifts reflect equal values of personnel for each of the three shifts including days, swings, and midnight shifts. After consulting with F-22 Heavy

Maintenance Modification Program leadership, the decision is made to simulate using the balanced shift approach for both current and future state, allowing for direct comparisons across the models and eliminating the limiting factor associated with ARENA 14®'s scheduling (preempt) function.

The personnel capacity for each specialty is set to the value of one shift of personnel. The model hours per day value is adjusted to reflect the duration of three shifts worth of labor hours, mimicking the number of hours that personnel would be available to complete maintenance in a given day. This method reflects the same personnel and labor hours available by scheduling three equal personnel, equal duration shifts. The only difference is the shift change is removed and the personnel continue on the job instead of instantaneously stopping maintenance, changing personnel, and restarting the same maintenance (processing) with the same type of person or resource.

The personnel values are based on SME feedback and reflect maintenance technicians scheduled in June of 2013. For simplification of cost calculations, the decision is made to consider all scheduled technicians as WG-10 employees even though the schedule includes some WL employees. The personnel numbers do not include personnel recently hired and awaiting clearances.

For the current state, one shift worth of personnel for each specialty are input into the model based on the values in Table 1. The future state doubles the number of personnel available in each of the specialties. Once the decision on resource inputs is made, the next step is the decision on data inputs.

**Table 1: Current State Personnel Resources**

Current State Balanced Schedule				
Manning Per Skill	Days	Swings	Mids	Total
AP (LO)	32	32	32	96
AS (Sheet Metal)	18	18	18	54
AR (Electrician)	4	4	4	12
AG_gen (A/C General)	7	7	7	21
AT (Fuels)	3	3	3	9
AV (ATE/Radar)	2	2	2	6
			Total	198

**Data**

The model scope decision led to using the Clemson scheduling tool for input data for the simulation but does not lead to a conclusion on the aircraft data sets to use from within the tool. In the next couple of sections the decisions on the type of data to input from within the Clemson tool, the aircraft data set sample size, and the percentage of arrivals for each type of aircraft are discussed.

The first decision is on the type of data to input or pull into the Clemson scheduling tool. The tool can import forecasted man-hour requirements per specialty per day based on the standard man-hours scheduled to complete the maintenance packages assigned or it can pull the actual man-hours per specialty per day that were used on an aircraft that has been previously completed. The decision is made to use standard man-hours required to complete an aircraft after comparing forecasted (standard) and actual man-hour requirements across several aircraft. The review is completed and discussed with SMEs and the Clemson scheduling tool does not pull in the O & A hours and therefore under reflects the man-hour requirements. However, the standard data overestimates AP man-hour requirements and the adjustments needed to compensate for

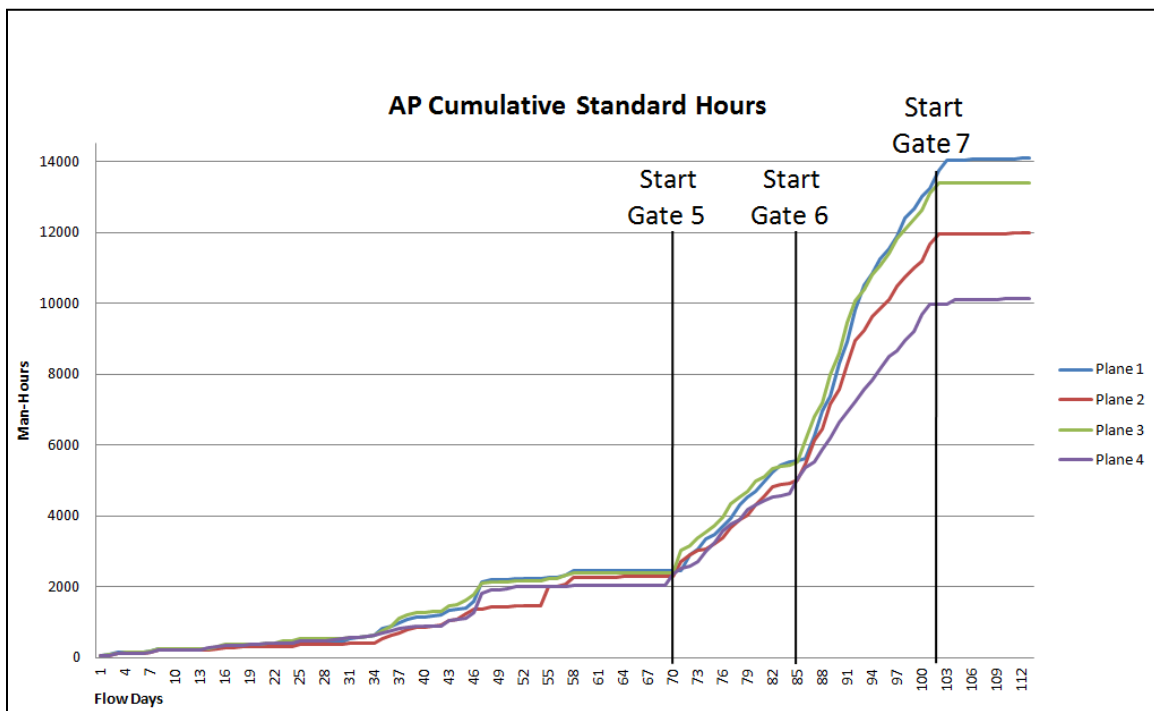
the overestimation is discussed in detail during a comparative analysis in later paragraphs. The decision to use standard man-hour requirements allows the researcher to proceed to the next decision, selection of the sample size of aircraft data for input use.

The selection of sample size is straightforward due to recent changes to the F-22 Heavy Maintenance Modification Program. The number of aircraft data sets to choose from is limited due to a change of their processes to the gate emphasis in July of 2012. Aircraft that were completed prior to that date are excluded because some tasks were realigned to reflect the milestone focus or to facilitate improvements identified by the new focus. This restricts the potential data sets to seven aircraft that have been completed under the new system at the time of model development.

Further narrowing the data sets available is the impact of minimizing and in some cases allowing no overtime at the end of FY 2013 due to sequestration. The aircraft completed during this period are eliminated to ensure the data sets are consistent in terms of work conditions, shifts, and overtime usage. These changes narrowed the potential sample size from seven aircraft to six aircraft.

Four aircraft data sets are selected for inputs from the six data sets available after discussions with SMEs and due to availability of flow day calculations and actual man-hour requirements compiled by the F-22 Flight planners. The planners' flow day calculations include all of the four aircraft selected and allow for potential validation comparisons on a one to one basis. Furthermore, the other two aircraft data sets reflect man-hour requirements that are similar to two of the aircraft selected. Additionally, the four aircraft data sets closely reflect the projected aircraft man-hour requirements for FY 2014 with man-hour requirements between 16,000 and 24,000 hours.

During a comparative analysis of the total hours used on the aircraft selected versus the standard projected man-hour requirements, the researcher found that the standard hours significantly over-forecasted the man-hour requirements for AP (Low Observable) technicians in three of the four aircraft. Plane 2 AP hours are within four percent of actual requirements but the other aircraft were over forecast by up to 40 percent. In order to assist in identifying the most likely area of deviation, the researcher plotted the AP cumulative forecast hours for the four aircraft against each other as seen in Figure 13. The figure identifies a few key points:



**Figure 13: AP Cumulative Standard Hours**

First, there are clearly delineated increases in AP hours as expected for Gates 5 and 6. Second, it confirms that most AP man-hour requirements exist in Gates 5 and 6 and reflects the real system as observed by the researcher and SMEs. Third, the large deviation in hourly requirements between aircraft begins in Gate 6. Finally, the

maximum actual AP (LO) hours used on any of the six aircraft in the computations by F-22 Planners are below 12,000 hours, however Figure 13 depicts two aircraft well over 12,000 hours. Further analysis of the daily forecast hours confirms that extreme man-hour requirements exist in the 17 days of Gate 6. By extreme, the researcher means hourly requirements for a day that need 14 days to complete given current constraints. Discussions with SME's on this issue further supports the finding that Gate 6 hourly requirements are over-estimated. The Gate 6 standard hourly requirements for AP are currently being adjusted by the F-22 Heavy Maintenance and Modification Program to accurately reflect current requirements.

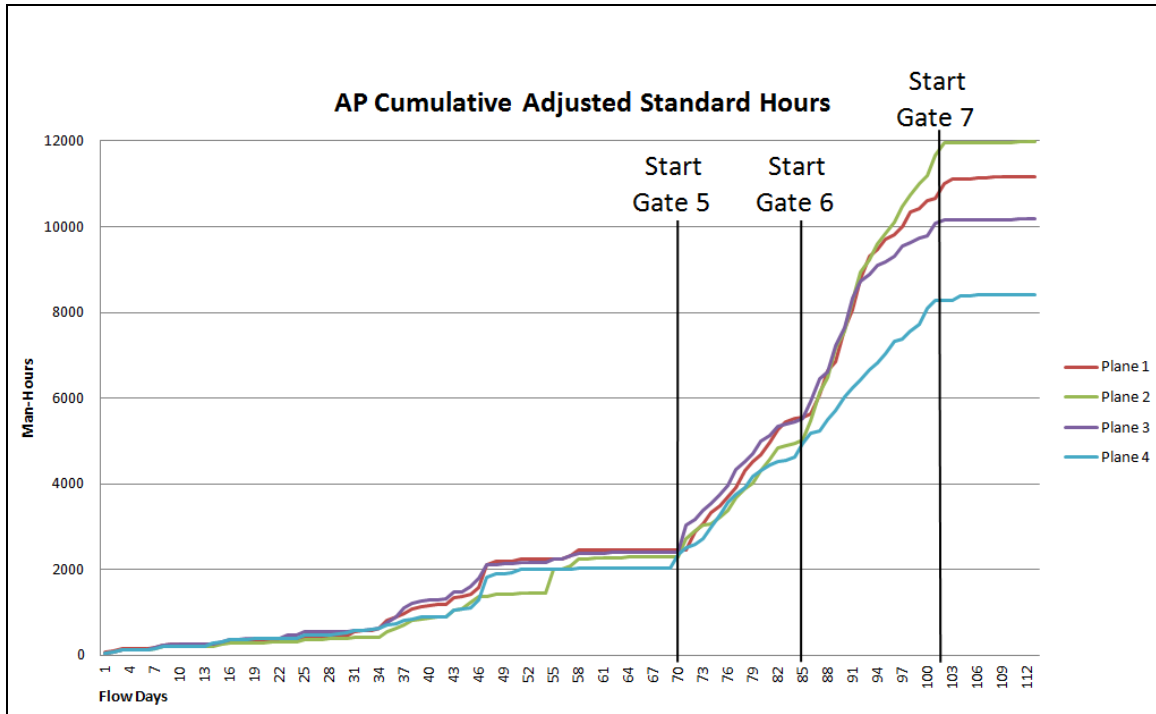
In order to solve this problem the decision is made to adjust Gate 6 AP over-estimated man-hour requirements to more accurately reflect the true system man-hour requirements. Hourly adjustments are made on three of the four aircraft and are conservative in order to adjust the over-estimates to be more representative of the real data while not trying to align the data exactly to the real aggregate man-hour requirements. The adjustment is made by subtracting two thousand five hundred hours from Plane 1 and 3 an average of 147 hours from each of the 17 days in Gate 6, because they were more than three thousand hours over-estimated. The researcher subtracts one thousand seven hundred hours from Plane 4, an average of 100 hours from each of the 17 days in Gate 6, because it was almost two thousand hours overestimated. Plane 2 is unaltered because the standard hours were more closely aligned with the real cumulative AP requirements. Table 2 identifies the differences between the standard total hours forecasted versus the actual aggregate hours used and then compares the adjusted standard total hours versus the actual aggregate hours used. Note that Plane 2 hours are

provided for comparison against the other three aircraft but the man-hours from standard to adjusted for Plane 2 remains unchanged.

**Table 2: AP Hours Standard vs Actual**

<b>AP Standard / Adjusted Standard Hours vs Actual Hours</b>					
<b>Aircraft</b>	<b>Category</b>	<b>Input Hrs</b>	<b>Actual Hrs</b>	<b>Difference</b>	<b>Deviation</b>
Plane 1	Standard AP	14090.2	10987.08	3103.12	28%
	Adjusted AP	11546.6	10987.08	559.52	5%
Plane 2	Standard AP	11976	11487.79	488.21	4%
	Adjusted AP	11976	11487.79	488.21	4%
Plane 3	Standard AP	13405	9581.39	3823.61	40%
	Adjusted AP	10906.7	9581.39	1325.31	14%
Plane 4	Standard AP	10122.9	8197.75	1925.15	23%
	Adjusted AP	8422.9	8197.75	225.15	3%

The adjustments do not eliminate the over-estimation but the adjusted data more accurately reflects the true system requirements for AP man-hours. Furthermore, Figure 14 shows that the variability in total AP man-hour requirements is retained between aircraft while eliminating the previous over-estimate values near 14 thousand man-hours. The adjustment is not a perfect solution but it is the best course of action given the data available for comparison. SMEs verified the adjustments were accurate compared to the real system, noting that they are currently adjusting the AP forecast standard hours to more accurately reflect the true requirements.

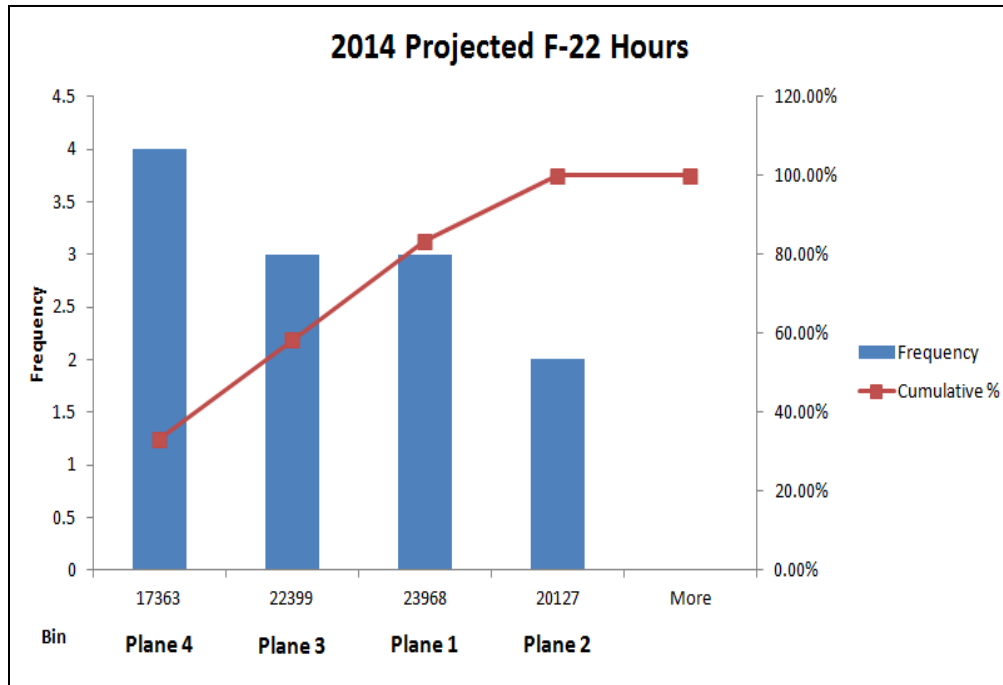


**Figure 14: AP Cumulative Adjusted Standard Hours**

The five other critical path maintenance specialties' man-hour requirements reflect percentage differences in man-hour requirements similar to the adjusted AP values. No adjustments are made to these specialties because a targeted adjustment of their hourly requirements is not feasible given the data currently available and the fact that their standard man-hour forecast is much closer to the true system man-hour requirements than the original AP standard man-hours. Once the input data is selected and adjusted, the next step is the decision on the aircraft type to enter the system.

The next step is to decide the input percentage for each of the four types of aircraft that arrives into the current system. The man-hour requirements for aircraft that have a projected induction in 2014 are analyzed to aid in the decision on the input percentages for each of the four aircraft data sets. The aircraft are separated into four bins based on their projected man-hour requirements compared to the four unadjusted

aircraft data sets that were selected for input. The unadjusted standard man-hour requirement is used because the assumption can be made that future projections will need similar adjustments, therefore, unadjusted data sets accurately reflect unadjusted projections for 2014. The bins reflect the percentage of aircraft that fall within each of the four data sets as shown in Figure 15.



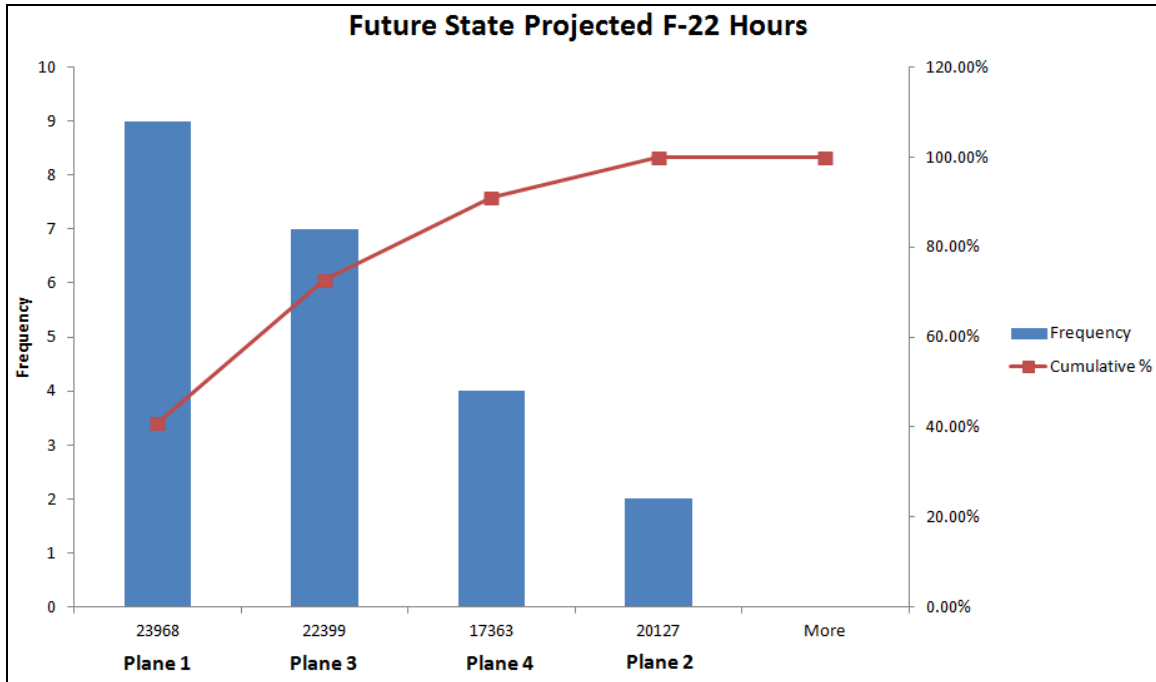
**Figure 15: 2014 Projected F-22 Hours (Bins)**

The percentages seen in Table 3 are then input into the model for the values of the ProbPlane1, ProbPlane2, and ProbPlane3 variables. Plane 4 does not need to be specified because all others (those not in the first three) travel the Plane 4 path, reflecting the last 33.33 percent of input aircraft.

**Table 3: Inputs-2014 Projection Bins**

<b><i>Plane</i></b>	<b><i>Bin</i></b>	<b><i>Frequency</i></b>	<b><i>Bin %</i></b>	<b><i>Cumulative %</i></b>
<b>Plane 4</b>	17363	4	33.33%	33.33%
<b>Plane 2</b>	20127	2	16.67%	50.00%
<b>Plane 3</b>	22399	3	25%	75.00%
<b>Plane 1</b>	23968	3	25%	100.00%

The future state model input percentages use the same methods as the current state model. The additional aircraft per year representing the addition of the Palmdale depot maintenance activities reflect higher man-hour requirements than the existing F-22 depot maintenance workload at Ogden. Additionally, the previously identified current state aircraft inputs remain representative of half the expected workload in the future state. After reviewing the F-22 Depot Flow Plan, the additional aircraft are binned with the previous aircraft, allocating 40 percent of the aircraft into the Plane 3 bin and 60 percent into the Plane 1 bin as shown in Figure 16.



**Figure 16: Future State Projected F-22 Hours**

The percentages seen in Table 4 are then input into the future state model for the values of the ProbPlane1, ProbPlane2, and ProbPlane3 variables. Plane 4 does not need to be specified because all others (those not in the first three) travel the Plane 4 path, reflecting the last 18.18 percent of input aircraft.

**Table 4: Future State Input Percentages**

<i>Plane</i>	<i>Bin</i>	<i>Frequency</i>	<i>Bin %</i>	<i>Cumulative %</i>
<b>Plane 4</b>	17363	4	18.18%	18.18%
<b>Plane 2</b>	20127	2	9.09%	27.27%
<b>Plane 3</b>	22399	7	31.82%	59.09%
<b>Plane 1</b>	23968	9	40.91%	100.00%

Recall that the custom VBA code previously described pulls the input data into the model for simulation runs based on the plane type assigned to each aircraft. The adjusted standard man-hour requirement data sets for the four input aircraft are copied

into a spreadsheet labeled Model Input Data.xls. Due to the access requirements associated with F-22 data, the sample Model Input Data spreadsheet in Appendix A reflects mock data. After inputs, the next methodology topic for description is verification and validation of the model.

*NOTE: The input spreadsheet must be saved as an .xls file or ARENA 14® will not interface with it correctly.*

## **Model Verification & Validation**

Verification and validation of a simulation model ensures the design and function accurately represents the behaviors of the real system. Recall that according to Carson (2005), “The result of the V & V phase is a verified, validated model that is judged to be accurate enough for experimentation purposes over the range of system designs contemplated” (p. 21). For this reason, the simulation model is built using a piecewise fashion with each verification and validation method being used continually throughout the process.

### **Verification**

Model verification serves to ensure the operational model accurately reflects the conceptual model and real system of interest. Building the simulation in a piecewise fashion and conducting verification prior to duplicating the function was key to minimizing errors and catching them early due to the complexity of the system being modeled and the time constraints associated with this study. The model was built one sub model and gate at a time similar to Ysebaert’s (2011) simulation research on F-22 Low Observable panels.

The first gate is built incrementally and animation is used to watch the basic processes such as separating and batching the aircraft, matching, and the re-loop function. Each time a new process was added the verification was recompleted. For instance, during the verification of the Characteristics sub model the `AwaitingInput` function was allowing one more aircraft than the WIP constraint value to enter the system. The equation symbol had to be changed from  $\leq$  to  $<$  to constrain WIP. Additionally, a delay function (`AV_Delay_SEizeDecision1`) was added in the AV1 Number sub model and its counterparts in the different specialty paths after visually finding a later aircraft passing an aircraft in the hold function of the sub model. This error violated the first in first out principals of the real system.

Perhaps the most significant error caught was the looping function error noticed through animation after creating Gate 2. The researcher duplicates Gate 1 for Gate 2 but the `ContinueFlag` attribute is deleted from the `Gate2_Start` module. This error causes the entities to exit Gate 2 after one flow day because the `ContinueFlag` was not reassigned a value of one. Recall that the VBA code assigns a value of zero when the next flow day is the start of the subsequent gate. The re-loop modules (`Continue AV?`, `Continue AT?`, etc.) allowed the aircraft to exit the gate because of this error. Several other abnormalities highlighted themselves and were corrected using visual verification through animation but not all processes are visible for verification purposes.

The more detailed functions and processes are verified using the variable display function in ARENA. The function allows a variable, attribute, or any calculated value to be seen in a display box. The numerical value of each variable is verified versus the expected value using a “trace” type method as described by Law (2007). The model

animation is slowed to a point that advancing from one event to the next can be followed. The attribute and variable values are checked against expected values, first with one aircraft flowing through the system then increasing the WIP to the constraint value. The most complicated verification during this process was the ProcessTime attribute. The VBA code pulls in the man-hour requirements for the current flow day prior to starting maintenance. In order to verify the correct data was being pulled the ProcessTime attribute was compared to the current flow day requirement as each event occurred. Additionally, the ProcessTime attribute was compared to the man-hour input data in the Model Input Data.xls spreadsheet based on the PlaneNum assigned to the aircraft in order to verify the correct plane data was input. Throughout the verification process outputs were continually validated for accuracy but final validation is done by comparing outputs against historical data and calculations from the real system.

### **Validation**

In model validation, the researcher seeks to ensure the model has sufficient accuracy to represent the real system (baseline model  $\approx$  real system) so that experimental comparisons and analysis can be completed on modified versions of the system (Carson, 2002). The functions of the model, inputs, and expected outputs based on input adjustments were validated throughout the model building and verification process. The next few paragraphs discuss the warm-up, run length, and replication number decision as well as the final model comparison against historical data from the real system.

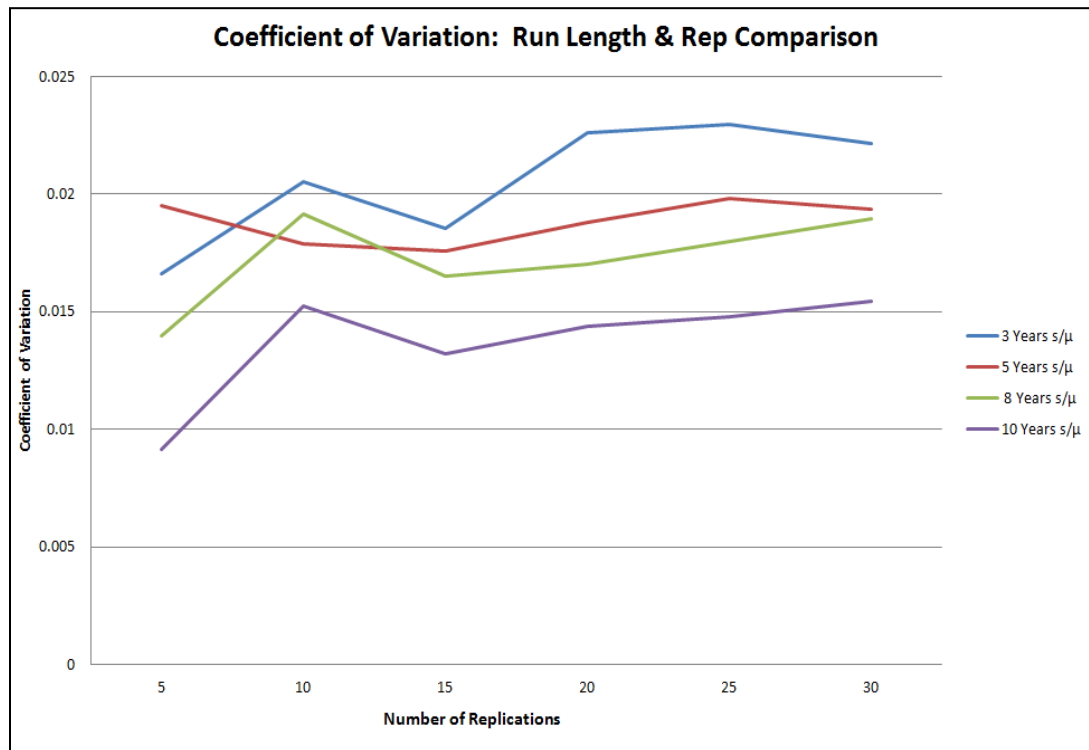
The warm-up period is set based on the steady parameter of having the current state number of WIP aircraft in the system at all times. The inter-arrival time and warm-

up period are calculated using the target throughput of aircraft per year for the current state and aircraft per year for the future state with 225 workdays per year. To find the inter-arrival time for the system, the researcher divides workdays by target throughput for the current and future state.

The warm-up period for the model is 100 days for the current state in order to get the current state work-in-process (WIP) aircraft in the system. The future-state warm-up period is 200 days to allow for future state WIP aircraft to be in the system at the start of statistic collection and to allow enough time for the first few aircraft to exit the system. The reasoning for allowing the first aircraft to exit the system is that personnel resource constraints do not affect the WIP aircraft until many more aircraft are in the system due to the doubling of personnel, allowing the early aircraft to flow through the system at an unrealistic rate with seemingly minimal resource constraints. The warm-up period is added to the run length decided upon in the next step.

The coefficient of variation (CV) is used to aid in the decision on run length and replication number. The current state CV comparison provides a clear picture on the dispersion characteristics across differing model run lengths and replication numbers. Figure 17 shows that a small amount of variation exists within the model with CVs between .009 and .022. The highest CV associated with a 3-year run length is reasonable because less than 28 aircraft flow through each of the 3-year replications and the variability in the model is solely dependent on the type and number of aircraft that arrive. Conversely, it shows that a run length of 8 to 10 years is favorable in order to increase the statistical accuracy of output comparisons. 10 years is chosen over 8 years because little CV difference exists between the two and the math is easier for comparing experiment

results against the 5-year multi-trade (multi-skill) analysis completed by Ogden Air Logistics Center (2012).



**Figure 17: Run Length & Rep Comparison**

The replication number selection includes reviewing Figure 17 to find the point where the CV stabilizes and to calculate the number of runs needed to estimate  $\theta$  by  $\bar{Y}$  to within  $\pm$  one day with a probability of 95% or an  $\alpha$  level of .05 (Banks et. al, 2010, p. 431). In order to get the desired level of precision, Equation 10 is applied with a  $\sigma$  and  $\mu$  value for the 8-year and 10-year run lengths. The R (replication) number needs to be greater than the value calculated. The results in Table 5 combined with Figure 17 support the decision to use 15 replications for the 10-year run length. Table 5 also includes the calculated R values for two days of precision, but the higher number of replications are

chosen for a precision of one day in order to facilitate statistical accuracy in the analysis portion of this research.

$$R > \left( \frac{t_{\frac{\alpha}{2}, R-1} S_o}{\epsilon} \right)^2 \quad (8)$$

**Table 5: Replication Calculation for Precision**

8-Year Run Length				10-Year Run Length			
T for 95% CI	S (10 Reps)	ε	> R Value	T for 95% CI	S (10 Reps)	ε	> R Value
2.26	2.54	1	33.02	2.26	2.04	1	21.23
T for 95% CI	S (15 Reps)	ε	> R Value	T for 95% CI	S (15 Reps)	ε	> R Value
2.14	2.2	1	22.26	2.14	1.77	1	14.43
T for 95% CI	S (20 Reps)	ε	> R Value	T for 95% CI	S (20 Reps)	ε	> R Value
2.09	2.26	1	22.38	2.09	1.92	1	16.17
8-Year Run Length				10-Year Run Length			
T for 95% CI	S (10 Reps)	ε	> R Value	T for 95% CI	S (10 Reps)	ε	> R Value
2.26	2.54	2	8.25	2.26	2.04	2	5.31
T for 95% CI	S (15 Reps)	ε	> R Value	T for 95% CI	S (15 Reps)	ε	> R Value
2.14	2.2	2	5.57	2.14	1.77	2	3.61
T for 95% CI	S (20 Reps)	ε	> R Value	T for 95% CI	S (20 Reps)	ε	> R Value
2.09	2.26	2	5.59	2.09	1.92	2	4.04

The final portion of validation consists of comparing flow day values calculated for the real system with the flow day outputs from the simulation model. The researcher starts by finding the expected flow days for an aircraft based on the man-hour requirements of the aircraft. F-22 Planners provide expected flow days. The burn rate calculations used for the expected flow day values represent a linear function based on the number of man-hours required by a given aircraft. Through observing the system and

analyzing the data, there are times when the function is not linear due to cure time or constraints on the number of personnel able to work an aircraft but the linear burn rate calculations represent the best comparison values available.

Second, the researcher calculates the average man-hour requirements expected for  $n$  aircraft flowing through the system based on the input percentages discussed in the Inputs section of this chapter and shown in Table 3. Third, the expected flow days for each of the four types of aircraft and the average aircraft are calculated. Finally, the expected flow days are compared to the model outputs for the current and future states depicted in Table 6 and Table 7.

**Table 6: Current State Validation - Expected vs. Model Flow Days**

<b>Current State Validation: Expected vs Model Flow Days</b>					
<b>Aircraft Category</b>	<b>Man-Hour Requirement</b>	<b>Expected Non-OT Days</b>	<b>Model Output</b>	<b>Delta</b>	<b>% Delta</b>
Plane 1	20471.60	144.60	141.92	-2.68	-1.86%
Plane 2	20127.10	142.17	141.69	-0.48	-0.34%
Plane 3	19900.60	140.57	138.80	-1.77	-1.26%
Plane 4	15663.10	110.64	121.69	11.05	9.99%
<b>Avg Aircraft</b>	18617.06	<b>131.50</b>	<b>133.99</b>	<b>2.49</b>	<b>1.89%</b>
Average Aircraft Flow Days 95% Confidence Interval		Lower 95% CI	133.01	Upper 95% CI	134.97

The Current State comparison shows the average flow days to be approximately 2.5 days over expected flow days, reflecting a longer flow time than expected by 1.89 percent. Additionally, the comparison reveals that most of the deviation with the model and expected days is attributed to Plane 4, the highest percentage of aircraft flowing through the system. The same comparison is conducted on the Future State model in Table 7.

**Table 7: Future State Validation - Expected vs Model Flow Days**

<b>Future State Validation: Expected vs Model Flow Days</b>					
<b>Aircraft Category</b>	<b>Man-Hour Requirement</b>	<b>Expected Non-OT Days</b>	<b>Model Output</b>	<b>Delta</b>	<b>% Delta</b>
Plane 1	20471.60	144.60	127.77	-16.83	-11.64%
Plane 2	20127.10	142.17	127.42	-14.75	-10.38%
Plane 3	19900.60	140.57	123.81	-16.76	-11.92%
Plane 4	15663.10	110.64	109.67	-0.97	-0.88%
<b>Avg Aircraft</b>	19384.41	<b>136.92</b>	<b>123.33</b>	<b>-13.59</b>	<b>-9.93%</b>
Average Aircraft Flow Days 95% Confidence Interval		Lower 95% CI	122.75	Upper 95% CI	123.91

The Future State comparison shows the average flow days to be approximately 13.59 days below expected flow days, reflecting a shorter flow time than expected by 9.93 percent. The 123.33 average flow days per aircraft is even below the flow day target with overtime of 125.61 days. This comparison uses the same burn rate from the Current State comparison, reflecting the current method for forecasting current and future flow day targets.

Further calibration of the number of direct labor hours per day available by increasing or decreasing model day length from 20 hours has a positive relationship to increasing and decreasing model flow day outputs but may allow for more or less direct labor hours during experimentation than exists in the real system. For this reason, no additional calibration of the model is completed in order to be more aligned to the 61.7 percent direct labor rate (38.3 percent indirect labor rate) or approximately 5.6 hour Output Per Man Day (OPMD) per technician target of the real system (Ogden Air Logistics Center, 2012).

Discussions with F-22 Heavy Maintenance Modification Program leadership and SMEs lead the researcher to the conclusion that the model is valid for the purpose of experimentation and decision analysis. I reiterate Carson's (2002) quote of the famous statistician George Box, "All models are wrong. Some are useful." (p. 53). Throughout verification and validation, the model has proven robust in producing reasonable values as different inputs are altered. With this in mind, the research now moves to the experimental design phase.

## **Marginal Analysis**

A marginal analysis method is used for analysis in this research. The marginal analysis design includes a resource add experiment in the current and future state. Another experiment using marginal analysis principles considers multi-skill policies, multi-skilling each specialty into the AP resource, and to concurrently multi-skill AP into the other five critical path specialties in the F-22 Heavy Maintenance and Modification Program. This experiment is conducted as a comparison between results from this research and the five-year BCA completed by Ogden ALC in 2012.

The first experiment is to add one person by specialty for each run, reflecting the addition of three additional personnel per day or one person in each of the three balanced shifts (1800 labor hours/person/year). Each experimental level contains six runs, one run for each specialty. Note that only one specialty has added personnel from the baseline for each run. The specialty that shows the most improvement in flow days from the additional personnel using the Select-the-Best Procedure spreadsheet developed by Banks et al. (2010) is retained as the new baseline for the next comparison. This method of marginal analysis is similar to Ysebaert's (2011) "shopping list" method but uses the Select-the-Best Procedure to choose the best system. This experiment will show the impact of adding personnel on flow days and provide a comparison for multi-skilling improvements.

In the event that a system is not differentiable from the baseline in the personnel add experiments, the baseline will remain the same and additional personnel will be added in each specialty and compared to the original baseline. The process is repeated until the outputs are differentiable. Each experiment ends when no difference exists as

personnel are increased or when the expected flow days with overtime are met.

Additionally, Paired-t test, ANOVA, and Tukey-Kramer multiple comparison analysis techniques are provided for informational purposes only to compare against the results of the Select-the-Best Procedure.

The second set of experiments for the current state of the model is to multi-skill all non-AP (LO) specialties into AP and all AP personnel into the other specialties. The number of AP personnel multi-skilled into each specialty will be limited to no more than the current number of personnel in the specialty. The experiment will include 10 levels, starting with all personnel multi-skilled and reducing the multi-skilled personnel across the board by 10 percent for each experimental level until only 10 percent of employees are multi-skilled. This experiment provides a direct comparison to the multi-trade policy analyzed in the BCA completed by Ogden ALC in 2012 to multi-trade almost all personnel into AP and all AP personnel into other specialties. Following the experiment to multi-skill only into and out of AP, a targeted approach to multi-skilling is conducted to see if the flow day targets can be reached using different multi-skilling approaches.

Similar experiments are conducted a second time on the future state of the model. The future state model will reflect the addition of the Palmdale work and will have an increased aircraft WIP and throughput per year. Additionally, the future state input probabilities for the type of aircraft to arrive in the system are used to reflect an increase in the man-hour requirements associated with the aircraft that previously underwent maintenance at Palmdale.

The future state model produces flow day averages 13.59 days below overtime targeted flow days and indicates the future state benefits from increasing returns of scale

or economies of scale (de Neufville, 1990) with the additional personnel and workload. For this reason, the future state analysis includes reducing personnel by 5 percent for each level down to a 25 percent reduction. The level that closely reflects the flow day target without overtime is then selected as a baseline for multi-skilling experiments.

Targeted multi-skilling experiments are then conducted using the selected reduction in workforce as the baseline model. The multi-skilling experiments identify if a more flexible workforce allows for reductions in personnel requirements for the future state of the system. Following selection of the best targeted multi-skilling alternative, another Personnel Add Marginal Analysis is conducted on the best multi-skilled alternative. This experiment identifies the number of personnel required to meet future state requirements with a multi-skilled workforce. Developing the model, deciding on inputs, and designing experimentation methods leads to conducting the experiments and analyzing the results.

## **IV. Results and Analysis**

### **Chapter Overview**

The following sections discuss employment of the analysis methods and the subsequent results. The chapter is organized in two sections including current state analysis and future state analysis. The first analysis is on the current state and begins with the Personnel Add Marginal Analysis.

### **Current State**

#### **Personnel Add Marginal Analysis**

In the Current State Personnel Add marginal analysis, one additional maintenance technician is added within each of the six specialty and each add is treated as a separate run (scenario). The Select-the-Best Procedure spreadsheet provided by Banks et al. (2010) is used to select the run with the best improvement over the baseline using a 95 percent confidence level, an indifference level of two days, and a sample size of 15 replications. The selected run is treated as the new baseline model and the subsequent personnel adds are done in the new baseline model for each level. The experiment mimics adding overtime to the model and the results represent the number of overtime hours needed to reach the average expected flow day target of 120.64 days with overtime-hourly burn rates per day from F-22 Planners. The expected 30,658 additional hours of overtime shown in the bottom right of the Table 8 is based on real world overtime usage for the aircraft selected as inputs.

The analysis runs over nine levels with the results shown in Table 8. The bolded and highlighted runs are selections as the best system for each level. Additionally, the

table includes P-values for each run's Student-t test against the baseline for comparison with the Select-the-Best Procedure results. The Oneway Analysis of flow days and Tukey-Kramer HSD multiple comparison results from JMP®, included in Appendix C, support the ranking results of the Select-the-Best Procedure even though statistically significant differences at the 95 percent confidence level do not exist in three of the eight experimental levels in which selections are made.

**Table 8: Current State - Personnel Add**

Current State - Marginal Analysis (Personnel Add) Experiment									
Level	Baseline Flow Days (133.99 Days)	Data Category	AP	AS	AR	AG	AT	AV	Man-Hours Added/Year
A1	Total Technicians Added	Additional Techs/Shift	1	1	1	1	1	1	5,400
	3	Avg Flow Days	134.10	132.45	133.53	<b>129.82</b>	132.88	132.79	Overtime Cost
		P Value (α = .05)	0.65	0.02	0.5	<b>&lt;.0001</b>	0.11	0.08	\$218,430
A2	Total Technicians Added	Additional Techs/Shift	1	1	1	<b>2</b>	1	1	10,800
	6	Avg Flow Days	129.94	129.31	130.17	<b>127.41</b>	127.92	129.29	Overtime Cost
		P Value (α = .05)	0.87	0.05	0.65	<b>0.0025</b>	0.01	0.49	\$436,860
A3	Total Technicians Added	Additional Techs/Shift	1	1	1	3	<b>1</b>	1	16,200
	9	Avg Flow Days	127.13	126.72	126.7	125.67	<b>125.26</b>	126.64	Overtime Cost
		P Value (α = .05)	0.7	0.36	0.34	0.02	<b>0.005</b>	0.24	\$655,290
A4	Total Technicians Added	Additional Techs/Shift	1	1	1	<b>3</b>	2	1	21,600
	12	Avg Flow Days	125.19	125.26	124.84	<b>123.54</b>	125.58	124.4	Overtime Cost
		P Value (α = .05)	0.93	0.99	0.6	<b>0.03</b>	0.69	0.28	\$873,720
A5	Total Technicians Added	Additional Techs/Shift	1	1	1	4	2	<b>1</b>	27,000
	15	Avg Flow Days	124.13	123.24	123.18	124.16	123.46	<b>122.34</b>	Overtime Cost
		P Value (α = .05)	0.48	0.71	0.66	0.46	0.92	<b>0.15</b>	\$1,092,150
A6	Total Technicians Added	Additional Techs/Shift	1	1	1	4	<b>2</b>	2	32,400
	18	Avg Flow Days	122.33	121.28	121.02	122.04	<b>120.96</b>	122.14	Overtime Cost
		P Value (α = .05)	0.98	0.13	0.06	0.66	<b>0.05</b>	0.77	\$1,310,580
A7	Total Technicians Added	Additional Techs/Shift	1	1	1	4	3	2	37,800
	21	Avg Flow Days	121.34	121	120.59	121.14	121.4	121.69	Overtime Cost
		P Value (α = .05)	0.6	0.95	0.61	0.8	0.55	0.33	\$1,529,010
A8	Total Technicians Added	Additional Techs/Shift	<b>3</b>	3	3	6	5	4	48,600
	27	Avg Flow Days	<b>115.5</b>	119.4	119.09	120.01	121.54	121.42	Overtime Cost
		P Value (α = .05)	<b>&lt;.0001</b>	0.04	0.016	0.22	0.44	0.54	\$1,965,870
A9	Total Technicians Added	Additional Techs/Shift	5	3	3	6	5	4	59,400
	33	Avg Flow Days	110.88	111.89	112.78	112.02	115.31	115.95	Overtime Cost
		P Value (α = .05)	<.0001	0.0003	0.006	0.0005	0.84	0.64	\$2,402,730
Flow Day Target with Overtime			120.64 Days		OT Hrs Expected in Real System			30,658	\$1,240,116

As expected, more flow day reductions occur in the first six levels of adding technicians with diminishing returns with each additional level. Adding AG technicians

in Levels A1 and A2 reduces the average flow days of an aircraft by approximately seven days. Adding AT personnel in Level A3 reduces average flow days by two days. Levels A3 through A6 result in a one or two-day reduction in flow days for each level. Note that no selection is made in Level A7, showing no decrease in flow days with the addition of 5,400 additional labor hours per specialty per year. In order to compensate for diminishing returns, Levels A8 and A9 adds two personnel in each specialty, reflecting an additional six total personnel per level. Level A8 results in a six flow day reduction from the Level A6 baseline, indicating that large amounts of AP overtime are needed in order to reduce flow days. The experiment concludes at Level A9 because the flow day target of 120.64 days is considered met in Level 6 and the additional 10-day reduction in flow days from Level A6 to Level A9 almost doubles overtime (additional personnel) requirements.

As indicated in Table 8, 32,400 overtime hours are required to reach the 120-flow day target in Level A6. Using the rates from the 2012 BCA completed by Ogden ALC, the overtime hours equate to \$1,310,580 in overtime costs with an overtime rate of \$40.45. The added 32,400 overtime hours closely mirrors the expected 30,658 additional hours of overtime based on real world overtime usage for the aircraft selected as inputs. The reduction of an additional six flow days from 120 days in Level A6 to 110 days in Level A9 requires an additional 27,000 hours of overtime, costing an additional \$1,092,150 in overtime costs.

A significant finding is that AP (LO) personnel provide the best return only twice in the 9 levels even though they are currently viewed as the main bottleneck resource. AG and AT personnel reflect a much lower portion of the man-hour

requirements and provide more return for hours added in 5 of the 9 levels. Oneway analysis of total flow days and a comparison of days spent in each gate, shown in Table 9, reveals that Gates 1, 3, and Gate 7 see the most flow day reductions with additional personnel and account for most of the reductions towards meeting flow day targets. This finding is consistent with the experimental selections to add additional personnel in non-LO specialties for 5 of the 9 experimental levels and reflecting that a majority of the non-LO man-hour requirements occur outside of Gates 5 and 6. Experimental Level A6 is highlighted to indicate the level that the average flow day target is met.

**Table 9: Current State – Personnel Add Gate Analysis**

Experimental Level	Personnel Add - Days Per Gate Comparison								
	Personnel Added	Gate 1	Gate 2	Gate 3	Gate 4	Gate 5	Gate 6	Gate 7	Difference
Baseline	N/A	23.63	20.43	23.11	N/A	14.82	23.37	16.49	N/A
A1	3 AG	-2.05	-0.13	-0.08	N/A	0.70	0.49	-2.90	-3.96
A2	3 AG	-2.80	-0.48	-0.40	N/A	1.29	1.12	-4.72	-5.99
A3	3 AT	-3.40	-0.99	-2.17	N/A	1.32	1.39	-4.53	-8.38
A4	3 AG	-4.17	-1.33	-1.91	N/A	1.49	1.80	-5.81	-9.93
A5	3 AV	-4.06	-1.11	-2.57	N/A	-2.77	1.54	-6.46	-15.43
A6	3 AT	-4.72	-1.53	-3.06	N/A	1.77	1.53	-6.57	-12.58
A7	3	N/A	N/A	N/A	N/A	N/A	N/A	N/A	N/A
A8	6 AP	-4.59	-1.86	-3.30	N/A	-0.22	-1.68	-6.38	-18.03
A9	6 AP	-4.87	-2.63	-4.55	N/A	-1.56	-2.93	-6.11	-22.65

Another item of note is that flow day increases are observed in LO Gates 5 and 6 as personnel are added into AG, AT, and AV. Showing that even though maintenance requirements are considered independent from one specialty to the next, complex interactions exist between the gates, aircraft within the gates, and specialties in use. This also shows the bottleneck shift more towards AP heavy gates as personnel capacity increases to speed up processing in the other gates. Following analysis of personnel adds, the multi-skilling analysis is conducted.

### **All AP Multi-skill Analysis**

The multi-skill analysis begins by multi-skilling the five non-AP specialties into AP and all AP personnel into the other five specialties using the methodology previously discussed. Each subsequent run reduces the number of multi-skilled personnel by 10 percent from 100 percent down to 10 percent.

Multi-skilling 100 percent of the workforce provided the best results, increasing average flow days by 1 day. Furthermore, multi-skilled workforce percentages from 90 percent to 10 percent increases flow days with the worst system performance of approximately 89 additional days at 60 percent. Table 10 depicts the full results, providing the number of multi-skilled personnel by specialty at each level, the average flow days, the delta from the baseline (status quo) average flow days, the number of multi-skilled hours per year, and the additional cost if multi-skilled personnel are paid more per hour using multi-trade policies from the 2012 Multi-Trade BCA. The cost data reflects the \$2.03 difference between WG-10 and WG-11 employee hourly wages multiplied by the number of multi-skilled employee hours per year using cost data from the 2012 BCA (Ogden ALC, 2012).

**Table 10: Current State – All AP Multi-skill Analysis**

Current State - Multi-skill AP ALL Experiment Analysis									
Level	Baseline Flow Days (133.99 Days)	Category	AP	AS	AR	AG	AT	AV	Total Multi-skilled
B1	100% Multiskilled	Multi-skilled/Shift	32	18	4	7	3	2	198
		Avg Flow Days	135.12	Delta	1.13	Multi-skill Hrs	400,950	Multi-Trade Cost	\$813,929
B2	90% Multiskilled	Multi-skilled/Shift	29	16	4	6	3	2	180
		Avg Flow Days	188.10	Delta	54.11	Multi-skill Hrs	364,500	Multi-Trade Cost	\$739,935
B3	80% Multiskilled	Multi-skilled/Shift	26	14	3	6	2	2	159
		Avg Flow Days	201.48	Delta	-67.49	Multi-skill Hrs	321,975	Multi-Trade Cost	\$653,609
B4	70% Multiskilled	Multi-skilled/Shift	22	13	3	5	2	1	138
		Avg Flow Days	220.56	Delta	86.57	Multi-skill Hrs	279,450	Multi-Trade Cost	\$567,284
B5	60% Multiskilled	Multi-skilled/Shift	19	9	2	4	2	1	111
		Avg Flow Days	223.51	Delta	89.52	Multi-skill Hrs	224,775	Multi-Trade Cost	\$456,293
B6	50% Multiskilled	Multi-skilled/Shift	17	9	2	4	2	1	105
		Avg Flow Days	213.70	Delta	79.71	Multi-skill Hrs	212,625	Multi-Trade Cost	\$431,629
B7	40% Multiskilled	Multi-skilled/Shift	16	8	2	3	1	1	93
		Avg Flow Days	142.28	Delta	-8.29	Multi-skill Hrs	188,325	Multi-Trade Cost	\$382,300
B8	30% Multiskilled	Multi-skilled/Shift	13	2	2	1	1	1	60
		Avg Flow Days	189.09	Delta	55.10	Multi-skill Hrs	121,500	Multi-Trade Cost	\$246,645
B9	20% Multiskilled	Multi-skilled/Shift	7	2	2	1	0	0	36
		Avg Flow Days	175.76	Delta	41.77	Multi-skill Hrs	72,900	Multi-Trade Cost	\$147,987
B10	10% Multiskilled	Multi-skilled/Shift	3	2	0	1	0	0	18
		Avg Flow Days	150.80	Delta	16.81	Multi-skill Hrs	36,450	Multi-Trade Cost	\$73,994

The results show that a fully multi-skilled workforce, specifically into and out of AP (LO), provides an average flow day increase of 1 day per aircraft at a cost of \$813,929. The other nine levels indicate significant flow day increases. The results lead to further interrogation of output data to gain insight into the areas within the system that show the most significant impacts from multi-skilling all specialties into and out of AP.

The next comparison looks at the differences in flow days within each gate across multi-skill percentage runs. Negative values are the desired state, indicating a reduction in days from the baseline. The results in Table 11 show that most of the flow day increases occur in Gates 2, 3, 5, and 6, showing an opposite result from the Personnel Add Marginal Analysis. Additionally, Gates 1 and 7 benefit from multi-skilling at 9 of the 10 levels but negatively impacting Gates 5 and 6, reflecting similar results to adding AG personnel in the Personnel Add experiment. These results show that more significant flow day increases occur in Gates 5 and 6 (LO gates) in which approximately 50 percent

of man-hour requirements on each aircraft exist, indicating that those requirements are delayed when AP personnel are completing maintenance actions in the five other specialties. Combined with the interactional effects observed in the personnel add experiment, this shows that an even spread of AP resources into the other five specialties is not desirable because complex interactions exist within the gates and periods of lower utilization within the five specialties do not align with AP requirements. The inverse is also true for lower AP utilization periods and the five specialties' requirements.

**Table 11: Current State – AP ALL Multi-skill Gate Analysis**

Level	Multi-skill All AP - Days Per Gate Comparison								
	Multi-skill %	Gate 1	Gate 2	Gate 3	Gate 4	Gate 5	Gate 6	Gate 7	Difference
Baseline	N/A	23.63	20.43	23.11	12.59	14.82	23.37	16.49	N/A
B1	100%	7.55	1.65	-5.32	-0.53	2.22	3.14	-7.57	1.14
B2	90%	-3.21	2.62	0.94	-0.56	27.56	33.96	-7.62	53.69
B3	80%	-4.04	5.91	3.62	-0.56	31.15	38.66	-7.4	67.34
B4	70%	-4.33	11.61	7.01	-0.57	39.15	43.09	-8.21	87.75
B5	60%	-2.12	12.26	7.4	-0.53	34.94	43.33	-5.28	90
B6	50%	0.77	9.19	6.45	-0.51	31	38.03	-4.82	80.11
B7	40%	1.35	0.47	-3.52	-0.4	5.66	7.55	-2.98	8.13
B8	30%	-7.05	3.56	2.94	-0.52	29.38	33.29	-6.63	54.97
B9	20%	-3.05	0.84	1.57	-0.19	18.66	23.52	-0.73	40.62
B10	10%	0.56	0.01	-0.61	-0.1	6.2	9.1	1.03	16.19

The results also show that flow day increases occur in non-LO gates as multi-skilling decreases, indicating that combining the smaller specialties into AP (LO) has a negative impact in Gates 2 and 3 at the 80 to 50 percent multi-skilled levels because AP has a much larger man-hour requirement and uses the multi-skilled resource more frequently. The unavailability of the multi-skilled person to complete their primary specialty has a much larger impact on the smaller specialties than on the larger resource pool of AP as multi-skilled levels decrease.

Another consideration is model Limitation 4, in which a multi-skilled person seized for maintenance actions is held to complete the task even though the primary specialty becomes available. This limitation may increase flow days for unfavorable policies because demand for the multi-skilled pairings are not offset and both resources have peak demands concurrently. This explains the larger increases in flow days with the mid and lower level percentages of multi-skilled personnel and highlights the unfavorability of the proposed policy.

These insights lead the researcher to conduct a targeted multi-skilling experiment to see if flow day reductions are attained through other multi-skilling policies.

### **Targeted Multi-skill Analysis**

The targeted analysis uses insights from the AP All multi-skill analysis as a starting point. The Targeted experiments focus on a paired method versus multi-skilling a few specialties into each other by using insights from utilization rates and man-hour requirements within each gate to selectively multi-skill each specialty with only one other specialty. Additional considerations are made for current resource capacity, seeking to pair resource pools with lower utilization rates with resource pools closest in size that required overtime hours in the Personnel Add. Table 12 shows the results of the Targeted Multi-skilling experiments.

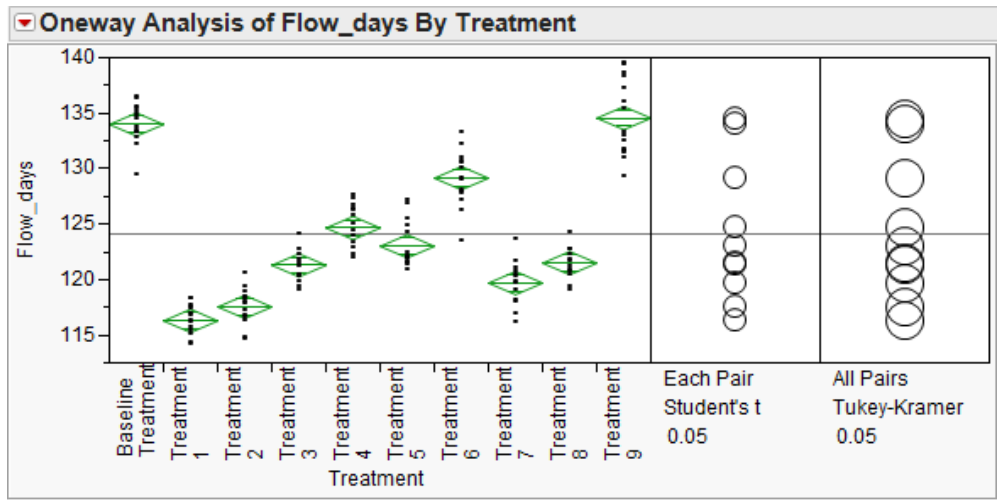
**Table 12: Current State - Targeted Multi-skill Analysis**

Current State - Targeted Multi-skill Experiment Analysis									
Level	Flow Days / Delta w/Baseline	Data Category	AP	AS	AR	AG	AT	AV	Total Multiskilled
C1	116.29	Additional Specialty	AS	AP	AG	AR	AV	AT	198
	-17.7	Multi-skilled/Shift	32	18	4	7	3	2	\$813,929
C2	117.55	Additional Specialty	AS	AP	AG	AR	AV	AT	150
	-16.44	Multi-skilled/Shift	16	18	4	7	3	2	\$616,613
C3	121.3	Additional Specialty	AS	AP	AG	AR	AV	AT	126
	-12.69	Multi-skilled/Shift	8	18	4	7	3	2	\$517,955
C4	124.66	Additional Specialty	AS	AP	AG	AR	AV	AT	114
	-9.33	Multi-skilled/Shift	4	18	4	7	3	2	\$468,626
C5	123.01	Additional Specialty	AS	AP	AG	AR	AV	AT	102
	-10.98	Multi-skilled/Shift	0	18	4	7	3	2	\$419,297
C6	129.15	Additional Specialty	AS	AP	AG	AR	AV	AT	96
	-4.84	Multi-skilled/Shift	8	8	4	7	3	2	\$394,632
C7	119.7	Additional Specialty	AS	AP	AT	AV	AR	AG	150
	-14.29	Multi-skilled/Shift	16	18	4	7	3	2	\$616,613
C8	121.5	Additional Specialty	AS	AP	AV	AT	AG	AR	150
	-12.49	Multi-skilled/Shift	16	18	4	7	3	2	\$616,613
C9	134.57	Additional Specialty	AR	AG	AP	AS	AV	AT	114
	0.58	Multi-skilled/Shift	4	18	4	7	3	2	\$468,626
Flow Day Target with Overtime			120.64 Days		OT Hours Expected in Real System			30,658	\$1,240,116

The initial pairings include AP and AS, AG and AR, and AT with AV. The first experimental run reduces flow day averages by approximately 17.7 days or 13.2% from the baseline of 133.99 days. The second run decreases the number of AP personnel multi-skilled by 50 percent to 16 personnel per shift, resulting in a flow day reduction of 16.4 days or 12.2% from the baseline. The following seven runs consider other levels of multi-skilled personnel and pairings but the first two initial pairings resulted in the largest flow day reductions, producing results below the flow day target with overtime of 120.64 days.

A Oneway analysis, Student's t and Tukey-Kramer means comparison is conducted on the flow day outputs to identify statistically significant differences. Using the Student's t and Tukey-Kramer methods with an  $\alpha$  level of .05, no statistically significant difference exists between the lowest two flow day averages in Levels

(Treatments) C1 and C2. The Oneway analysis in Figure 18: Current State – Targeted Multi-skilling JMP® Oneway Analysis, depicts overlapping 95 percent confidence intervals for Treatment 1 and 2 as well. Therefore, both levels are retained as the best for future analysis.



**Figure 18: Current State – Targeted Multi-skilling JMP® Oneway Analysis**

Overall, the Targeted Multi-skilling Analysis shows that selective multi-skilling of 198 or 150 personnel in paired specialties can reduce the average flow days of an aircraft by 17.7 and 16.44 days with no additional personnel resources. If multi-trade type pay incentives are applied, the additional cost for 198 multi-skilled employees is \$813,929 per year or \$616,613 for 150 personnel using the 2012 BCA rates (Ogden ALC). With the Personnel Add and Multi-skilling experiments complete, results comparisons are conducted to identify and summarize the best alternatives for the current state of the system.

## **Current State – Results Summary**

Comparison of the current state results compiles results data from Tables 8, 10, and 12. It also includes additional model run outputs for the Targeted Multi-skilling lowest flow day scenarios from Table 12, in which the efficiency of the labor force is reduced within each run from 98 percent down to 90 percent. The efficiency changes reflect previous research indicating varying levels of proficiency reductions associated with a more generalized workforce (Levien, 2010).

Table 13 provides a list of the best results from each experimental design as well as results from across the analyses with similar flow day outputs. The delta column indicates the difference from the baseline (status quo) model outputs. The annual throughput column indicates the aircraft throughput per year, calculated by taking the total throughput of aircraft for the 10-year run length and dividing by 10. The cost column is calculated by taking the overtime and multi-skill hour column value and multiplying by \$40.45 per overtime hour or \$2.03 per multi-skill hour (Ogden ALC, 2012).

**Table 13: Current State - Results Summary**

<b>Current State Experiments - Results Summary</b>					
<b>Experiment Name (Level)</b>	<b>Flow Days</b>	<b>Delta w/Baseline</b>	<b>Annual Throughput</b>	<b>Overtime / Multi-skill Hrs</b>	<b>Annual Cost</b>
Baseline	133.99	N/A	9.90	N/A	N/A
Personnel Add - Overtime (A8)	115.5	<b>-18.5</b>	11.30	48,600	\$1,965,870
Targeted Multi-skilling (C1)	116.29	<b>-17.7</b>	11.27	400,950	\$813,929
Targeted Multi-skilling (C2)	117.55	<b>-16.4</b>	11.14	303,750	\$616,613
Targeted 98% Efficient (C1)	119.8	<b>-14.2</b>	11.03	400,950	\$813,929
Targeted 98% Efficient (C2)	120.92	<b>-13.1</b>	10.87	303,750	\$616,613
Personnel Add - Overtime (A6)	120.96	<b>-13.0</b>	10.92	32,400	\$1,310,580
Targeted Multi-skilling 95% Efficient (C1)	123.16	<b>-10.8</b>	10.77	400,950	\$813,929
Personnel Add - Overtime (A4)	123.54	<b>-10.5</b>	10.67	21,600	\$873,720
Targeted Multi-skilling 95% Efficient (C2)	124.9	<b>-9.1</b>	10.60	303,750	\$616,613
Personnel Add - Overtime (A3)	125.26	<b>-8.7</b>	10.58	16,200	\$655,290
Personnel Add - Overtime (A1)	129.82	<b>-4.2</b>	10.24	5,400	\$218,430
Targeted Multi-skilling 90% Efficient (C1)	130.22	<b>-3.8</b>	10.20	400,950	\$813,929
Targeted Multi-skilling 90% Efficient (C2)	131.25	<b>-2.7</b>	10.15	303,750	\$616,613
AP All Multi-skill 100% (B1)	135.12	<b>1.1</b>	9.70	400,950	\$813,929
<b>Average Flow Day Target w/OT</b>	<b>120.64</b>				<b>Expected OT Cost for Real System</b>
					<b>\$1,240,116</b>

The summarized results show that multi-skilling a workforce using Targeted policies with no efficiency losses produce flow day averages similar to the best overtime scenario. The cost difference between the best Targeted policy (C1) and overtime policy (A8) shown in Table 13 is approximately \$1,151,941 annually or \$5,759,705 over five years. The second best Targeted policy provides a two-day difference from the best overtime result with a cost difference of \$1,349,257 annually or \$6,746,285 over five years. In both Targeted Experiments C1 and C2, the flow day outputs fall below the flow day target of 120.64 days using overtime hours per day burn-rates from the Suggested Flow Day spreadsheet provided by F-22 planners.

Furthermore, reductions in efficiency levels to 98 percent (reflective of 2 percent longer processing times) for the Targeted policies still fall below the flow day target with overtime of 120.64 days. Again, reflecting a cost difference between multi-skilling and

overtime of \$693,967 annually for Targeted Experiment 2 (C2) and \$496,651 annually for Targeted Experiment 1 (C1), both at 98 percent efficiency. Further reducing the efficiency level of the workforce diminishes the cost differences between overtime and Targeted multi-skilling with break-even points occurring at 95 percent efficiency for both Targeted policies. Indicating that maintenance actions can take 5 percent longer before the overtime and multi-skilling policies are approximately equivalent in terms of cost. One point of interest is that Targeted Multi-skilling Experiment C2 includes 48 fewer multi-skilled personnel than Experiment C1. If efficiency losses occur, the impacts would be less under the policy with fewer multi-skilled personnel.

Finally, the results support the hypothesis of productivity increases and cost savings from multi-skilling proposed in the BCA completed by Ogden ALC in 2012. However, the results indicate that multi-skilling all five of the non-LO FWS maintenance specialties into LO, as prescribed by the BCA, is not a desirable policy in terms of flow day reductions, annual aircraft throughput, and cost. Following the analysis and comparison of overtime and multi-skilling in the current state model, the researcher moves to experimentation and analysis of the future state model.

## **Future State**

The future state analysis includes three sections, a Personnel Reduction Analysis, Targeted Multi-skilling Analysis, and Multi-skilled Personnel Add Analysis. The goal of this group of experiments is to ascertain whether targeted multi-skilling policies allow for a reduction in future maintenance personnel requirements. The first experiments conducted are the Personnel Reduction Analysis.

## Personnel Reduction Analysis

The future state analysis begins with double the personnel resources from the current state and reduces personnel by 5 percent for each level down to a 25 percent reduction. Table 14: Future State - Personnel Reduction displays the results from these experiments. The flow day target indicated at the bottom of the table represents the target flow days for the average aircraft requiring 19,384 critical path hours. The 136.92 day target is calculated using non-overtime burn-rate calculations from the Banded Flow Day Suggestions provided by F-22 Planners. The average aircraft maintenance labor-hour requirement would be approximately 22,000 critical path hours without adjustments for over forecasting of AP hours, reflecting an aircraft requiring over 25,000 total maintenance hours with an overtime flow day target of 144 days.

**Table 14: Future State - Personnel Reduction**

Future State - Personnel Reduction Experiment												
Level	Redux %	Data Category	AP	AS	AR	AG	AT	AV	Personnel Per Shift	Total Personnel	Cost	Flow Days
Baseline	N/A	Personnel	64	36	8	14	6	4	132	396	\$27,449,037	123.33
D1	0.05	Reduction / Shift	3	2	0	1	0	0	6	18	\$1,247,684	
		Total / Shift	61	34	8	13	6	4	126	378	\$26,201,354	129.08
D2	0.1	Reduction / Shift	6	4	1	1	1	0	13	39	\$2,703,314	
		Total / Shift	58	32	7	13	5	4	119	357	\$24,745,723	132.92
D3	0.15	Reduction / Shift	10	5	1	2	1	1	20	60	\$4,158,945	
		Total / Shift	54	31	7	12	5	3	112	336	\$23,290,092	142.49
D4	0.2	Reduction / Shift	13	7	2	3	1	1	27	81	\$5,614,576	
		Total / Shift	51	29	6	11	5	3	105	315	\$21,834,461	150.38
D5	0.25	Reduction / Shift	16	9	2	4	2	1	34	102	\$7,070,207	
		Total / Shift	48	27	6	10	4	3	98	294	\$20,378,831	162.66
											Flow Day Target w/o OT	136.92

The results show that each reduction of personnel by 5 percent increases average flow days between 5.75 days and 12 days more than the previous reduction level. Additionally, a cost reduction/avoidance of more than \$1,247,684 is realized for each 5 percent reduction in personnel.

The 15 percent reduction level is chosen over the 10 percent reduction level as the baseline for multi-skilling experiments because it is above the flow day target of 136.92 days. The researcher seeks to start above the target flow days in order to allow for maximization of multi-skilling benefits associated with personnel reductions. Subsequent experiments conducted in a multi-skilled environment re-add the personnel that most benefit the system. Following the identification of the 15 percent reduction level as the baseline for multi-skilling, a targeted multi-skilling experiment is completed on the new baseline.

### **Targeted Multi-skill Analysis**

The future state Targeted Multi-skill Analysis used insights garnered from the current state experiments to multi-skill the new baseline model, reflecting a 15 percent reduction in personnel resources. The analysis included 11 experimental levels, multi-skilling different numbers of personnel and specialties at each level. Table 15: Future State – Multi-skill Targeted Analysis (15% Reduction) shows the results of the analysis.

The multi-skilled cost is calculated by multiplying the total multi-skilled hours added by \$2.03, the difference between WG-10 and WG-11 burdened hourly rates. The total cost is garnered by multiplying the total number of personnel by the WG-10 wage rate of \$34.23 and then adding the multi-skilled cost for the number of multi-skilled employees. Both cost columns represent the dollar figure on an annual basis. The flow day target with overtime is calculated using the overtime burn-rates from the Banded Flow Day Suggestions provided by F-22 Planners and is displayed in the bottom right of

the table. Additionally, the baseline flow days represent the 15 percent Personnel Reduction scenario value of 142.49 flow days.

**Table 15: Future State – Multi-skill Targeted Analysis (15% Reduction)**

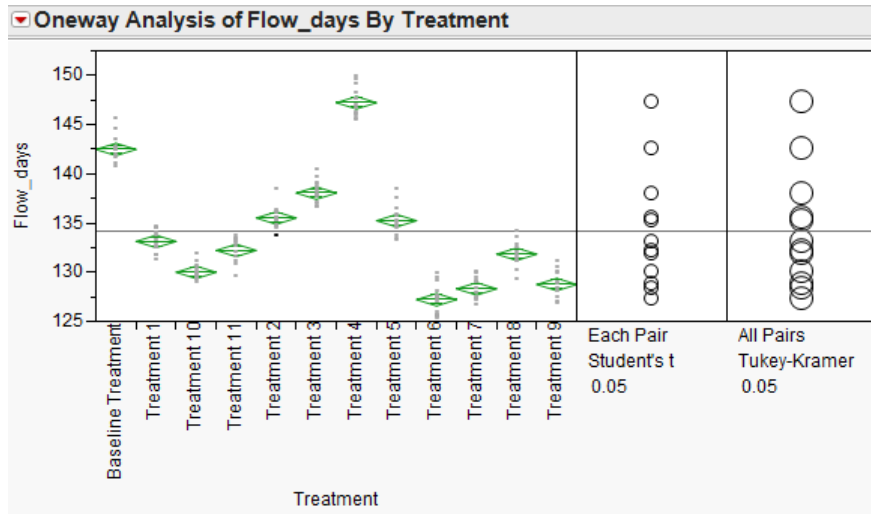
Future State - Targeted Multi-skill Experiment Analysis (15% Personnel Reduction)										
Level	Flow Days / Delta w/Baseline	Data Category	AP	AS	AR	AG	AT	AV	Total Multiskilled / Cost	Total Personnel / Cost
E1	133.14	Additional Specialty	AS	AP	AG	AR	AV	AT	186	336
	-9.35	Multi-skilled/Shift	22	13	7	12	5	3	\$764,600	\$24,054,692
E2	135.52	Additional Specialty	AS	AP	AG	AR	AV	AT	162	336
	-6.97	Multi-skilled/Shift	18	9	7	12	5	3	\$665,942	\$23,956,034
E3	138.06	Additional Specialty	AS	AP	AG	AR	AV	AT	138	336
	-4.43	Multi-skilled/Shift	14	5	7	12	5	3	\$567,284	\$23,857,376
E4	147.24	Additional Specialty	AS	AP	AG	AR	AV	AT	114	336
	4.75	Multi-skilled/Shift	10	1	7	12	5	3	\$468,626	\$23,758,718
E5	135.25	Additional Specialty	AS	AP	AG	AR	AV	AT	153	336
	-7.24	Multi-skilled/Shift	22	13	3	5	5	3	\$628,945	\$23,919,037
E6	<b>127.22</b>	Additional Specialty	AS	AP	AG	AR	AV	AT	<b>336</b>	<b>336</b>
	<b>-15.27</b>	Multi-skilled/Shift	54	31	7	12	5	3	<b>\$1,381,212</b>	<b>\$24,671,304</b>
E7	128.32	Additional Specialty	AS	AP	AG	AR	AV	AT	288	336
	-14.17	Multi-skilled/Shift	38	31	7	12	5	3	\$1,183,896	\$24,473,988
E8	131.84	Additional Specialty	AS	AP	AG	AR	AV	AT	240	336
	-10.65	Multi-skilled/Shift	38	15	7	12	5	3	\$986,580	\$24,276,672
E9	<b>128.76</b>	Additional Specialty	AS	AP	AG	AR	AV	AT	<b>240</b>	<b>336</b>
	<b>-13.73</b>	Multi-skilled/Shift	22	31	7	12	5	3	<b>\$986,580</b>	<b>\$24,276,672</b>
E10	130.05	Additional Specialty	AS	AP	AT	AV	AR	AG	288	336
	-12.44	Multi-skilled/Shift	38	31	7	12	5	3	\$1,183,896	\$24,473,988
E11	132.23	Additional Specialty	AS	AP	AG	AR	AV	AT	192	336
	-10.26	Multi-skilled/Shift	22	15	7	12	5	3	\$789,264	\$24,079,356
Baseline Flow Days from 15% Personnel Reduction			142.49		Flow Day Target with Overtime				125.61	

The experiments paired the smaller specialties for multi-skilling and paired AP (LO) and AS (Sheet Metal) personnel based on previous experimental results. The results show that targeted multi-skilling of the reduced workforce can reduce flow days by 15.27 days in Level E6, within 2 days of overtime targets at an annual cost of \$24,671,304 with all personnel multi-skilled. Levels E7 and E9 show similar results by reducing flow days by approximately 14 days at a cost of \$24,473,988 and \$24,276,262. The difference of 48 multi-skilled AP personnel between the two levels indicates diminishing returns with higher levels of multi-skilled AP technicians into AS.

Furthermore, all experimental levels except Level E4 resulted in flow day reductions. Level E4 multi-skilled low numbers of AP and AS personnel with no changes to the other specialties and provided the least desirable flow day averages. Levels E1 through E4 indicate that decreasing AP and AS multi-skilled personnel have an inverse affect on flow day averages.

Level E5 mimics Level E2 but decreases the multi-skilled personnel in the AG and AR pairing, resulting in a 2-day increase in flow days from Level E2. This comparison supports the finding that multi-skilling the entirety of personnel in the smaller specialties provides the best results. Limitation 4 may further hinder targeted optimization of the smaller specialties because it causes multi-skilled personnel to complete maintenance actions even if the primary specialty becomes available, overestimating the need for multi-skilled personnel. For this reason, Levels E6 through E11 considered only multi-skilling the entirety of the smaller specialties.

The small difference in flow days between Level E6, E8, and E9 led the researcher to complete a JMP® Oneway Analysis of flow days for all levels, displayed in Figure 19. The analysis appears to show overlap of the 95 percent confidence intervals of the Levels E6, E8, and E9. Further interrogation is conducted through means comparisons for all levels using Tukey-Kramer methods in JMP®. The results are displayed in Figure 71 in Appendix C, indicating no statistically significant difference exists between the means of Levels E6 and E7 or Levels E7 and E9 even though resource differences of 48 multi-skilled AP personnel exist between each pair.



**Figure 19: Future State - Targeted Multi-skill Oneway Analysis**

In order to capture a larger picture of the trade space between multi-skilling numbers for AP, Levels E6 and E9 are retained for the next experiment, the Multi-skill Personnel Add Analysis.

### **Multi-skilled Personnel Add Analysis**

The Multi-skilled Personnel Add Analysis is conducted identically to the Current State Personnel Add. One person is added per run (scenario) for each specialty and the best run is selected using the Select-the-Best Procedure spreadsheet provided by Banks et al. (2010). This analysis includes two experiments, one using Level 6 (E6) resource values from the Targeted Multi-skilling experiments as a baseline and one using Level 9 (E9) values. The first experiment completed is the personnel add for E6.

The E6 personnel add spans four levels, adding one person to each of three multi-skilled specialties and selecting the best alternative. The results are depicted in Table 16: Future State – 15% Redux Targeted Multi-skilling Add (E6). Since all personnel are multi-skilled, the total annual cost is calculated by multiplying the total personnel by

2025 hours per year (representative of the 225 day per year planning factor/model run length with nine hour shifts), then multiplying by the burdened WG-11 wage rate of \$36.26 (Ogden ALC, 2012). The shaded results represent the selection at each level and the P Value represents the Student's t comparison against the baseline. Student's t and Tukey-Kramer multiple comparisons from JMP® are included in Appendix C for comparison against the Select-The-Best Procedure. The comparison rankings from the baseline agree with the selections made for each experiment.

**Table 16: Future State – 15% Redux Targeted Multi-skilling Add (E6)**

<b>Future State - 15 % Reduction Targeted Multi-skilling (E6) (Personnel Add)</b>						
<b>Level</b>	<b>Multi-skilled Baseline (127.22 Days)</b>	<b>Data Category</b>	<b>AP/AS</b>	<b>AR/AG</b>	<b>AT/AV</b>	<b>Total Personnel / Annual Cost</b>
F1	Total Technicians Added	Additional Techs/Shift	1	1	1	339
		Avg Flow Days	126.23	125.54	126.31	Cost
	3	P Value ( $\alpha = .05$ )	0.01	<.0001	0.02	\$24,891,584
F2	Total Technicians Added	Additional Techs/Shift	1	2	1	342
		Avg Flow Days	124.24	124.32	124.82	Cost
	6	P Value	<.0001	0.0002	0.02	\$25,111,863
F3	Total Technicians Added	Additional Techs/Shift	2	2	1	345
		Avg Flow Days	123.58	123.16	124.04	Cost
	9	P Value	0.02	0.0005	0.5	\$25,332,143
F4	Total Technicians Added	Additional Techs/Shift	2	3	1	348
		Avg Flow Days	122.41	121.89	122.45	Cost
	12	P Value	0.03	0.0007	0.04	\$25,552,422
<b>Baseline Flow Days w/ No Personnel Reduction</b>			<b>123.33</b>	<b>Flow Day Target w/ OT</b>		<b>125.61</b>

The flow day target is reached in the first level with the addition of three AR/AG personnel, totaling 339 multi-skilled personnel with a total annual cost of \$24,981,584. Note that Level F3 reaches the baseline future state (with no personnel reduction) model flow day average of 123.33 with 345 personnel, 53 fewer personnel than the baseline of 398. The experiments are concluded at Level F4 with 348 multi-skilled personnel and a flow day average of 121.89 days at an annual cost of \$25,552,422. Following the E6

Personnel Add, the same experiments are conducted on the second retained level from the Targeted Multi-skilling Analysis, E9.

The E9 personnel add includes seven experimental levels and four runs (scenarios) per level. The only difference between the E6 experiments and these experiments are the AP personnel that are not multi-skilled, requiring one additional run per level. The results for the seven experimental levels with selections shaded are displayed in Table 17: Future State – 15% Redux Targeted Multi-skilling Add (E9). The Student’s t and Tukey-Kramer multiple comparisons from JMP® are included in Appendix C for comparison against the Select-The-Best Procedure and again support the selections made.

**Table 17: Future State – 15% Redux Targeted Multi-skilling Add (E9)**

Future State - 15 % Reduction Targeted Multi-skilling (E9) (Personnel Add)								
Level	Multi-skilled Baseline (128.76 Days)	Data Category	AP	AP/AS	AR/AG	AT/AV	Total Multi-skilled / Annual Cost	Total Personnel / Annual Cost
G1	Total Technicians Added	Additional Techs/Shift	1	1	1	1	243	339
	3	Avg Flow Days	128.57	128.47	127.86	128.72	Multi-skilled Cost	Total Cost
		P Value (α = .05)	0.65	0.5	0.04	0.91	\$998,912	\$24,496,952
G2	Total Technicians Added	Additional Techs/Shift	1	1	2	1	246	342
	6	Avg Flow Days	127.18	126.62	126.55	127.29	Multi-skilled Cost	Total Cost
		P Value (α = .05)	0.11	0.004	0.003	0.18	\$1,011,245	\$24,717,231
G3	Total Technicians Added	Additional Techs/Shift	1	1	3	1	249	345
	9	Avg Flow Days	126.19	125.58	126.39	126.23	Multi-skilled Cost	Total Cost
		P Value (α = .05)	0.35	0.01	0.68	0.41	\$1,023,577	\$24,937,511
G4	Total Technicians Added	Additional Techs/Shift	1	2	3	1	252	348
	12	Avg Flow Days	124.99	124.77	124.74	125.05	Multi-skilled Cost	Total Cost
		P Value (α = .05)	0.13	0.02	0.03	0.18	\$1,035,909	\$25,157,790
G5	Total Technicians Added	Additional Techs/Shift	1	3	3	1	252	351
	15	Avg Flow Days	123.65	124.07	123.96	124.31	Multi-skilled Cost	Total Cost
		P Value (α = .05)	0.007	0.1	0.05	0.3	\$1,035,909	\$25,365,737
G6	Total Technicians Added	Additional Techs/Shift	2	3	3	1	255	354
	18	Avg Flow Days	123.21	122.97	123.25	123.19	Multi-skilled Cost	Total Cost
		P Value (α = .05)	0.2	0.05	0.24	0.18	\$1,048,241	\$25,586,017
G7	Total Technicians Added	Additional Techs/Shift	2	4	3	1	258	357
	21	Avg Flow Days	122.54	122.07	121.07	122.49	Multi-skilled Cost	Total Cost
		P Value (α = .05)	0.006	0.02	0.006	0.22	\$1,060,574	\$25,806,296
Baseline Flow Days w/ No Personnel Reduction			123.33	Flow Day Target w/ OT			125.61	

The 125.61 flow day target with overtime is reached in Level G3, requiring 249 multi-skilled personnel and 345 personnel at an annual cost of \$24,717,937. The baseline

future state (with no personnel reduction) model flow day average of 123.33 is considered met in Level G5 with 252 multi-skilled personnel and 351 total personnel, 42 personnel less than the baseline model. The experiment concludes at Level G7 with an average flow day output of 121.07 days, 4.5 days below the flow day target with overtime. Following the Personnel Reduction Analysis, Targeted Multi-skilling Analysis, and Multi-skilled Personnel Add Analysis the results of the Future State Analyses are compiled for comparison and summary.

### **Future State – Results Summary**

Comparison of the current state results compiles results data from Tables 14, 16, and 17. The results also include additional model run outputs for efficiency reductions associated with a multi-skilled labor force. Each run decreases efficiency from 98 percent down to 90 percent for the Targeted Multi-skilling Personnel Add best flow day scenarios from Table 16 and 17.

Table 18 provides a list of the best results from each experimental design as well as results from across the analyses with similar flow day outputs. The delta column indicates the difference from the flow day target with overtime based on the Banded Flow Day Suggestions provided by F-22 Planners. The annual throughput column indicates the aircraft throughput per year, calculated by taking the total throughput of aircraft for the 10-year run length and dividing by 10. The cost column indicates the total annual cost as calculated in the previous experiments.

**Table 18: Future State – Results Summary**

<b>Future State Experiments- Results Summary</b>						
<b>Experiment Name (Level)</b>	<b>Flow Days</b>	<b>Delta w/ Target Flow Days</b>	<b>Annual Throughput</b>	<b>Multi-skilled Personnel</b>	<b>Total Personnel</b>	<b>Annual Cost</b>
E9 Multi-skill Personnel Add Best (G7)	121.07	-4.5	22.04	257	357	\$25,806,296
E6 Multi-skill Personnel Add Best (F4)	121.89	-3.7	22.08	348	348	\$25,552,422
E9 Multi-skill Personnel Add (G6)	122.97	-2.6	21.86	255	354	\$25,586,017
E6 Multi-skill Personnel Add (F3)	123.16	-2.5	21.82	345	345	\$25,332,143
Baseline Model (No Reduction)	123.33	-2.3	21.81	0	396	\$27,449,037
E9 Multi-skill Personnel Add (G5)	123.65	-2.0	21.74	252	351	\$25,365,737
E9 Multi-skill Personnel Add Best (G7) 98% Efficient	124.47	-1.1	21.61	257	357	\$25,806,296
E6 Multi-skill Personnel Add Best (F4) 98% Efficient	124.75	-0.9	21.57	348	348	\$25,552,422
E9 Multi-skill Personnel Add Best (G7) 95% Efficient	128.31	2.7	21.02	257	357	\$25,806,296
E6 Multi-skill Personnel Add Best (F4) 95% Efficient	128.46	2.9	20.92	348	348	\$25,552,422
Personnel Reduction 5% (D1)	129.08	3.5	20.86	0	378	\$26,201,354
Personnel Reduction 10% (D2)	132.92	7.3	20.28	0	357	\$24,745,723
E6 Multi-skill Personnel Add Best (F4) 90% Efficient	135.5	9.9	19.88	348	348	\$25,552,422
E9 Multi-skill Personnel Add Best (G7) 90% Efficient	135.88	10.3	19.82	257	357	\$25,806,296
<b>Average Flow Day Target w/Overtime</b>	<b>125.61</b>					

The summarized results show that multi-skilled workforce scenarios with no efficiency loss and between 37 and 51 fewer personnel produce results superior to the baseline model with no personnel reductions. Additionally, the second best E6 experiment produces statistically equivalent flow day outputs to the baseline with a reduction in workforce of 51 personnel and a cost avoidance/savings of \$2,116,984 annually or \$10,584,470 over 5 years. The third best E9 scenario provides very similar flow day and cost avoidance/savings results as the second best E6 scenario.

Even with a 2 percent increase in all daily maintenance-processing times, the best multi-skilled scenarios beat flow day targets by approximately 1 day. A 5 percent increase in all processing times as reflected in the 95 percent efficiency scenarios miss the flow day target by 2.7 and 2.9 days. However, both scenarios provide a cost avoidance/savings of at least \$1,642,741 annually or \$8,213,705 over 5 years. The cost difference provides space to add overtime or personnel to compensate for the increased processing times.

The experimentation and analysis of the current and future state models provide valuable insights into the benefits associated with multi-skilling personnel within the F-22 Heavy Maintenance and Modification Program. The researcher makes several conclusions and recommendations based the benefits of multi-skilling identified in this research.

## **V. Conclusions and Recommendations**

### **Answers to Research Questions**

The research ends where it began, seeking to answer the research questions developed in collaboration with F-22 Heavy Maintenance Modification Program leadership. The following paragraphs provide answers and recommendations based on the research questions posed and findings within this research.

**Research Question 1:** Which maintenance specialties within F-22 Depot Operations should be considered for multi-skilling into the low observable (LO) specialty?

The results and analysis of this research identify several pairing opportunities for multi-skilling. Aircraft throughput, employee utilization, and cost savings support the recommendation for multi-skilled pairing of personnel in Low Observable specialty with Sheet Metal, Aircraft Mechanics with Aircraft Electricians, and Fuels technicians with Avionics technicians. Additionally, aircraft throughput and flow day averages show that system performance decreases only slightly when pairing Aircraft Mechanics with Avionics technicians and Electricians with Fuels technicians.

Furthermore, the research provides the insight that the smaller capacity specialties benefit the system more through pairings with similar capacity specialties and in the same manner pairing the larger specialties (LO and Sheet Metal) show the most benefit to system performance. This finding is supported by the Current State Personnel Add experiments.

The Current State Personnel Add experiments show that overtime hour additions have a greater return on investment for the smaller specialties of Aircraft Mechanics, Aircraft Fuels Systems Mechanics, and Avionics technicians than for Painters (LO).

Much larger increases in overtime hours are required before the benefits outweigh adding to the smaller specialties. These insights support the finding that pairing smaller specialties with LO hinder system performance because the smaller specialties do not provide enough additional labor hours to affect overall system performance and negatively influence the requirements of the smaller specialties. This finding also indicates that future improvement efforts should focus on the smaller specialties first because small improvements in these areas result in greater impacts to system performance.

**Research Question 2:** How does multi-skilling increase aircraft throughput and employee utilization in F-22 Depot Operations?

In both current and future operational states of the system, targeted multi-skilling policies with no productivity losses increase aircraft throughput to levels exceeding the current overtime policies with significant cost savings/avoidance. Furthermore, the research shows that the best performing multi-skilling policies are cost favorable for a given level of aircraft throughput up to the 95 percent efficiency level. Meaning that multi-skilling is favorable up to the point that all maintenance requirements processing times increase by 5 percent due to productivity losses associated with a more generalized workforce. At that point, overtime and multi-skilling become cost equivalent with further processing time increases causing overtime to be more desirable.

Additionally, utilization of employees and available labor hours improves significantly with multi-skilling, as is evident by the experimental results showing significant improvements in aircraft flow day and throughput measures with a multi-skilled workforce. In both the current and future state experiments, a multi-skilled

workforce provided more annual throughput and direct labor hour usage than a workforce of equal or greater size with no multi-skilling.

**Research Question 3:** To what extent does multi-skilling offset overtime use to meet aircraft flow day requirements and throughput targets?

As discussed in answering Question 2, a multi-skilled workforce exceeds the flow day and throughput targets with cost performance superior to overtime. Additionally, this research supports the assertion included in the Multi-trade Demonstration Project BCA, highlighting that multi-skilling provides the opportunity to “increase the amount of Organizational and Intermediate level work on the aircraft while it is already opened for maintenance, thus reducing future number of iterations of LO removal and restoration process at the base level” (Ogden Air Logistics Center, 2012, p. 19). The potential benefits to the operational customer should be included in the conversation regarding overtime reductions, cost savings, and increased throughput.

Finally, the results support the hypothesis of productivity increases and cost savings from multi-skilling proposed in the BCA completed by Ogden ALC in 2012. However, the results indicate that multi-skilling all five of the non-LO FWS maintenance specialties into LO, as prescribed by the BCA, is not a desirable policy in terms of flow day reductions, annual aircraft throughput, and cost.

### **Limitations**

The limitations of this study are that cost calculations of multi-skilling (multi-trade) did not include considerations for clearances or additional training. Additionally, the aggregate level of data used and overuse of multi-skilled personnel associated with

the ARENA 14® seize limitation hinders optimization of multi-skilled personnel.

Finally, time constraints and lengthy model run time limited the analysis to one factor at a time adjustments, which do not give a full picture of the interactions and interdependency of input variables and their impact on outputs.

## **Future Research**

This research concludes by identifying opportunities for further research. AFMC should undertake future research in four areas. The five areas include:

- 1) Simulation of future weapon system depot processes during the design phase to assess personnel requirements and potential multi-skilling levels and benefits. The researcher would recommend looking for software with more fidelity and capabilities in terms of resource related scheduling and seizing (possibly an agent-based or object oriented simulation software).
- 2) Methods for implementing a flexible (multi-skilled) workforce to decrease the impact proficiency losses associated with more generalization.
- 3) Many previous studies and reports identify data accuracy issues associated with maintenance task times. Further research should look at the level and amount of data needed for useful decision-making and research efforts within the ALC's and broader Air Force aircraft maintenance arena. If everyone knows the task level data is inaccurate, there may be targets of opportunity to decrease the amount of data inputs required by technicians and still capture the level of information needed.

- 4) The Clemson MORS tool should be further developed to incorporate over and above task hours into the actual hour data pulled in. Other depot maintenance activities outside of the F-22 program would benefit from this tool in a version modified to fit their processes.
- 5) Further research should focus on ways to reduce non-value added time of maintenance technicians to increase availability of direct labor hours.

## Appendix A-Model Description

### Full Model Description

The following sections detail the full description and development of the model built in ARENA 14® for this research. The simulation model developed in ARENA 14® is based on the conceptual model from Figure 3.

The F-22 (entity of interest) flows through eight main sub models including Characteristics and a separate sub model for each of the Gates 1 through 7 as depicted in Figure 20: Top Level Model. For the current state baseline model the aircraft arrives every 19 days based on a target annual throughput of aircraft with 225 workdays per year. Once the aircraft is processed in all eight main sub models it exits the system and is disposed of in the Depart process. The variable views showing zeros track the variables indicated by the title above each one as the model runs.

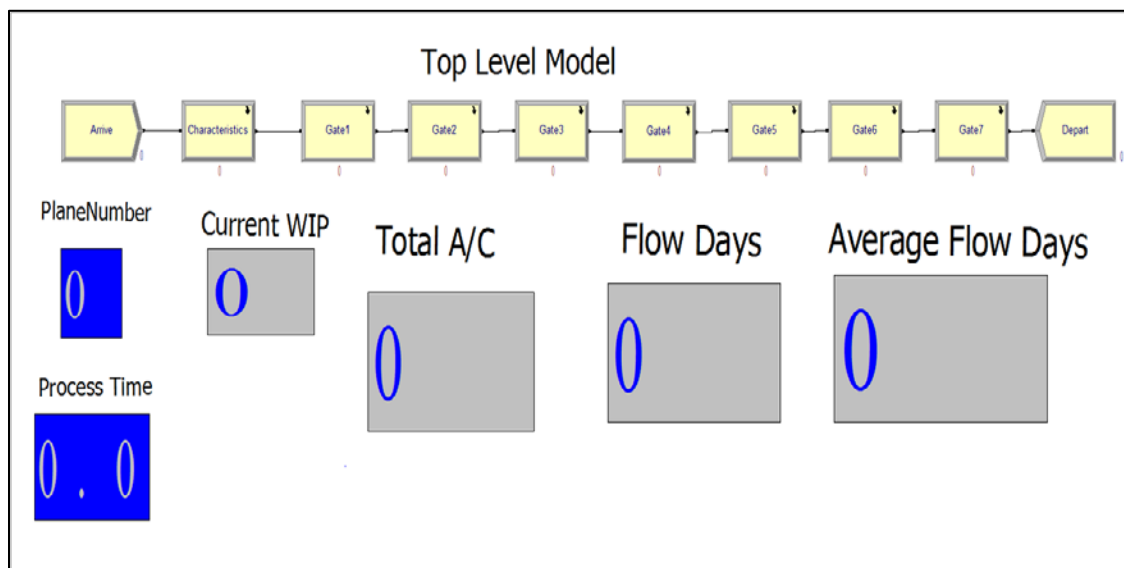
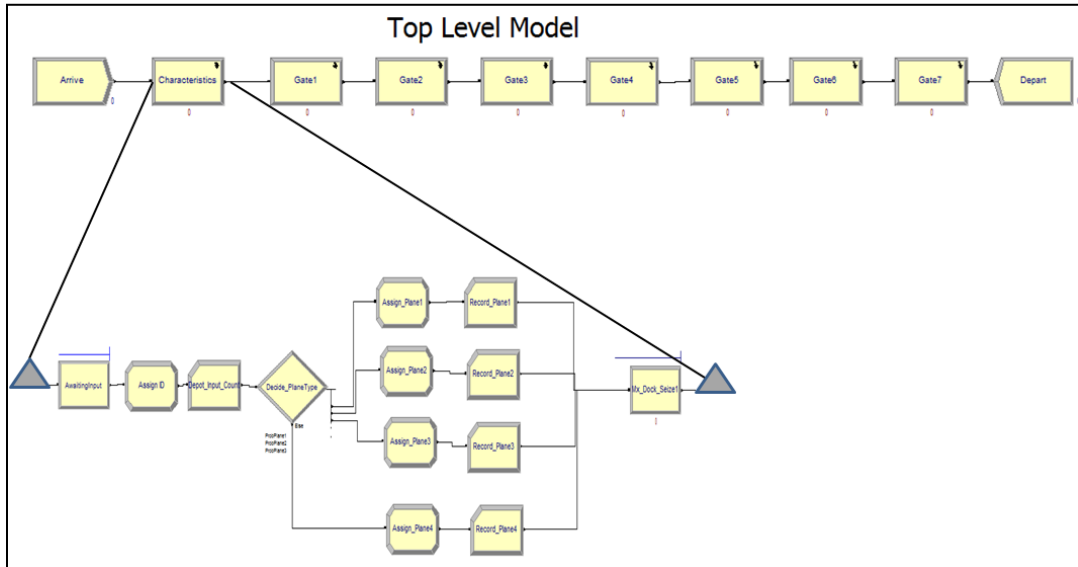


Figure 20: Top Level Model

## Characteristics Sub Model

After entity creation the aircraft flows into the Characteristics sub model as seen in Figure 21.



**Figure 21: Characteristics Sub Model**

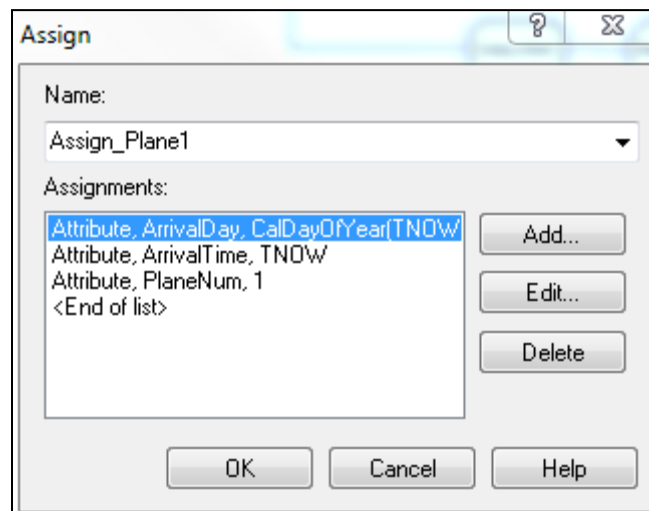
The aircraft flows through the AwaitingInput module and is held until the number of work-in-process (WIP) aircraft in the system is less than the maximum WIP constraint using Equation 11. The WIP\_Constraint variable is used as the maximum WIP constraint and the value is initially set at six to reflect the current constraint of the real system.

$$\begin{aligned}
 &(Gate1.WIP + Gate2.WIP + Gate3.WIP + Gate4.WIP + \\
 &Gate5.WIP + Gate6.WIP + Gate7.WIP) < WIP\_Constraint \quad (9)
 \end{aligned}$$

The aircraft then flows into the Assign ID process and is assigned a unique identification (ID) number, a unique ID variable, and a plane picture for animation purposes. Next, the aircraft is counted as a depot input and the decision is made on the type of plane arriving based on random chance with a certain probability of the four

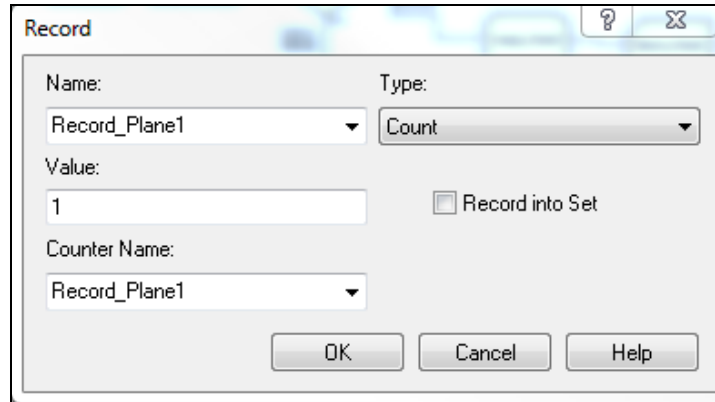
different types of arrivals being selected. The decide module uses ARENA's standard random number generation stream and is the only stochastic input in the model. The random selection of the four types of aircraft induces man-hour requirement variability into the system and is a critical factor to accurately reflect the variability of real system inputs. The four plane types are used in Gates 1 through 7 sub models to assign man-hour requirements for maintenance processing times. The decision on the number of plane types and selection of hourly requirements is discussed later in the Inputs portion of this chapter.

Once the decision is made on the type of plane arriving it is assigned attributes for the type of plane (PlaneNum), arrival day (ArrivalDay), and arrival time (ArrivalTime). Figure 22 shows the parameters in the Assign\_Plane1 module and is representative of the other three plane types with the exception of the PlanNum value.

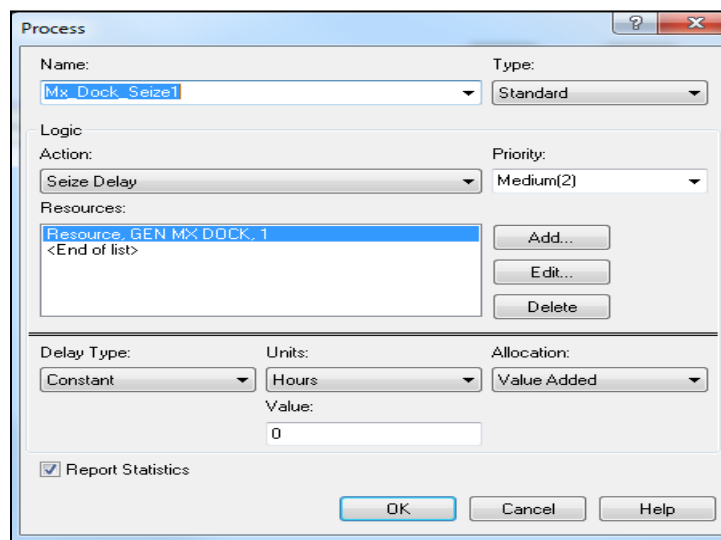


**Figure 22: Assign\_Plane1**

Then the type of plane is recorded, a general maintenance dock is seized and the aircraft exits the Characteristics sub model and is defined as work-in-process (WIP).



**Figure 23: Record\_Plane1**

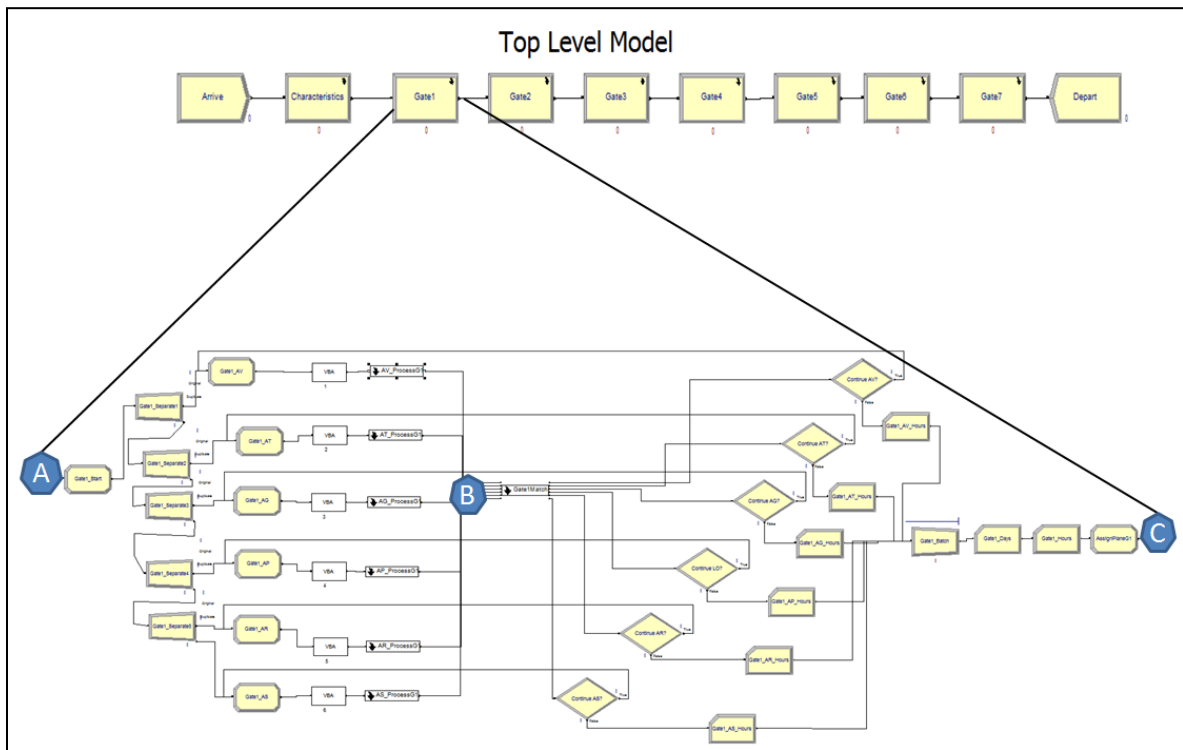


**Figure 24: Mx\_Dock\_Seize1**

### **Gate 1 Sub Model**

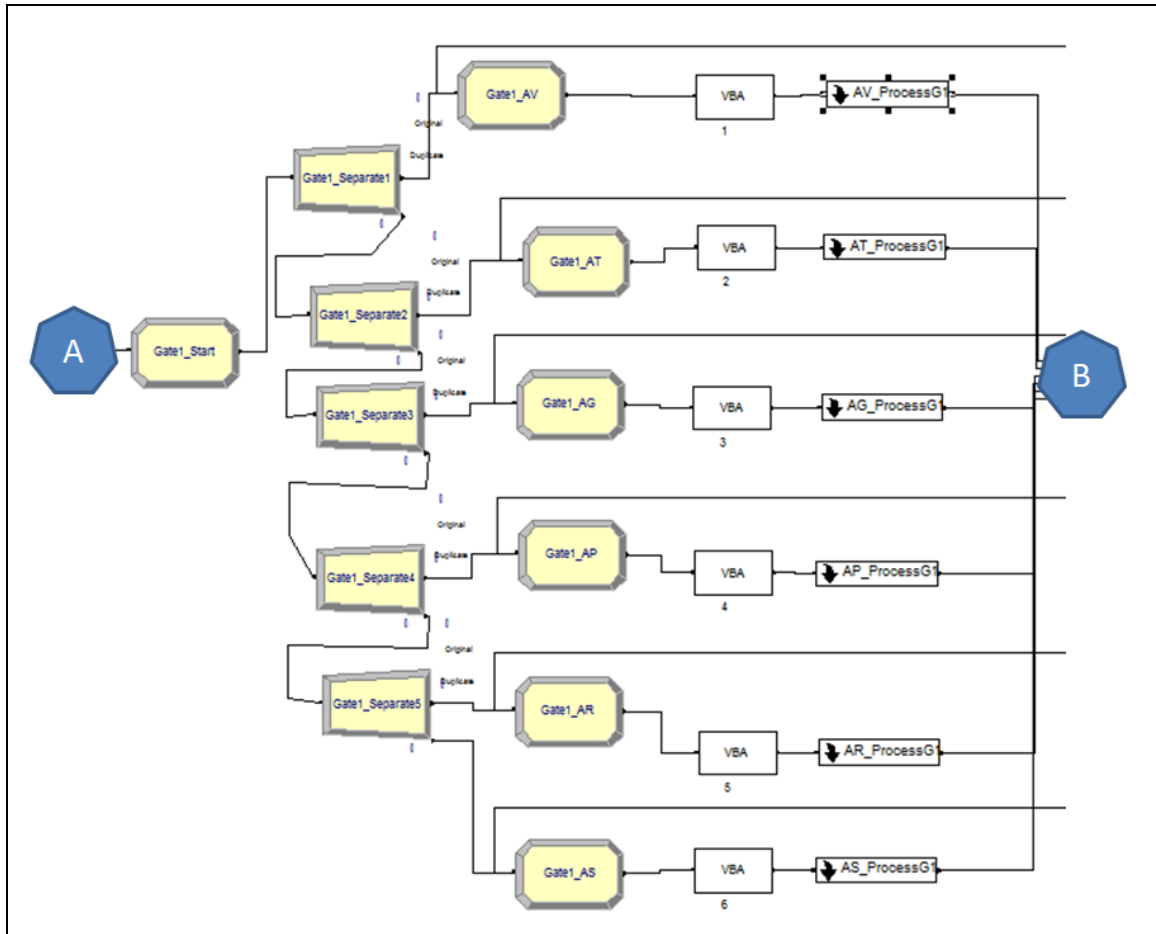
Transformations from inputs into outputs through the completion of maintenance hour requirements begin in Gate 1. The previous sub model is used to determine the plane type or PlaneNum attribute based on the four possible plane types and then constrains the system to a defined WIP value. Gate 1 uses the attributes defined in the Characteristics sub model for decisions on processing times per specialty as the aircraft moves from one day to the next. The Gate 1 sub model (shown in Figure 25) is broken

down into six main processes, two main sub models with several record functions used to tally statistics throughout the gate.



**Figure 25: Gate 1 Sub Model**

The next few paragraphs discuss the first four processes and the ProcessG1 sub model in Gate 1 and are depicted in Figure 26.



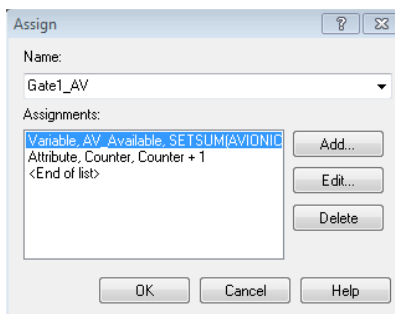
**Figure 26: Gate 1 Sub Model (a)**

The first process upon entering Gate 1, Gate1\_Start, assigns four attributes to the aircraft including: ContinueFlag = 1, Gate1\_StartDay = CalDayOfYear(TNOW), Gate1\_Begin = TNOW, and ProcessTime. All attributes and variables are described in detail in the process in which they are used in order to aid in understanding. The only part of this module that changes in Gates 2-7 is the numerical character depicting the current gate. For example, in Gate 2 the Gate1\_StartDay attribute is now Gate2\_StartDay and subsequent gates reflect the same change in numerical characters to correspond to the gate the aircraft currently resides. One thing to highlight is that the ContinueFlag attribute must be assigned at the beginning of each gate in order for the

VBA code and loop function (discussed later in the VBA & ContinueAV? descriptions) to work correctly within each gate. Next, the aircraft is separated into six different entities using five separate blocks and then flows into separate paths representing the six FWS specialties of interest.

In queuing theory terms, each path represents a different type of server required to complete a specific type of maintenance. The system has six types of servers (FWS maintenance specialties) that can do maintenance and using a different path design allows resource pooling based on the type of server. When multi-skilling is introduced the server is able to complete maintenance hours associated with multiple resource pools versus just one. The paths are replicas of each other with minor equation differences. Only the AV (avionics) path is discussed in detail to avoid duplication and the differences of the paths are subsequently detailed. For consistency purposes, the separated aircraft is referred to as entities and again described as an aircraft when they are joined back together.

The separated entity flows into an assign module, Gate1\_AV depicted in Figure 26 in which a global variable (AV\_Available) and attribute (Counter) are assigned.



**Figure 27: Gate1\_AV**

The AV\_Available variable assigns the current value based on the number of avionics technicians available in the set of resources called AVIONICS using Equation 12.

$$AV\_Available = NumberAvailable - NumberBusy \quad (10)$$

The AVIONICS set includes the avionics personnel (AV resource) and a separate multi-skill resource for each of the five other specialties paired with AV (AP\_AV, AS\_AV, etc). The benefits of using a set are discussed in detail later in the maintenance process description of the methodology. The Counter attribute is given a value +1 and adds one to the count every time the entity flows through the assign module.

### **VBA Block**

Following the assign module the aircraft advances to a visual basic application (VBA) block. The block runs custom VBA code that first finds the path for an excel document (Model Input Data.xls) containing man-hour requirements by specialty and flow day for four different aircraft. The document needs to be open prior to running the model to minimize run time associated with continually opening the document. The run time issues are discussed further in the verification section.

Next, the VBA code looks to the tab for one of the four aircraft based on the PlanNum attribute. Then it starts at the first day of requirements for the given specialty path the aircraft is in and assigns the man-hour requirement value to the ProcessTime attribute. Concurrently the code references a different row and cell for the following flow day that identifies the start of the next gate. It changes the ContinueFlag attribute value to zero when the next flow day is the start of the next gate. Once the ProcessTime

and ContinueFlag values are assigned, the aircraft proceeds to a sub model called AV\_ProcessG1.

### AV\_ProcessG1 Sub Model

The AV\_ProcessG1 sub model performs two main functions 1) it decides on the number of maintenance personnel to seize in order to fulfill daily man-hour requirements for the aircraft and 2) it seizes the aircraft and personnel resources for the required numbers of hour to meet the days maintenance requirements. The path through the four processes is depicted Figure 28.

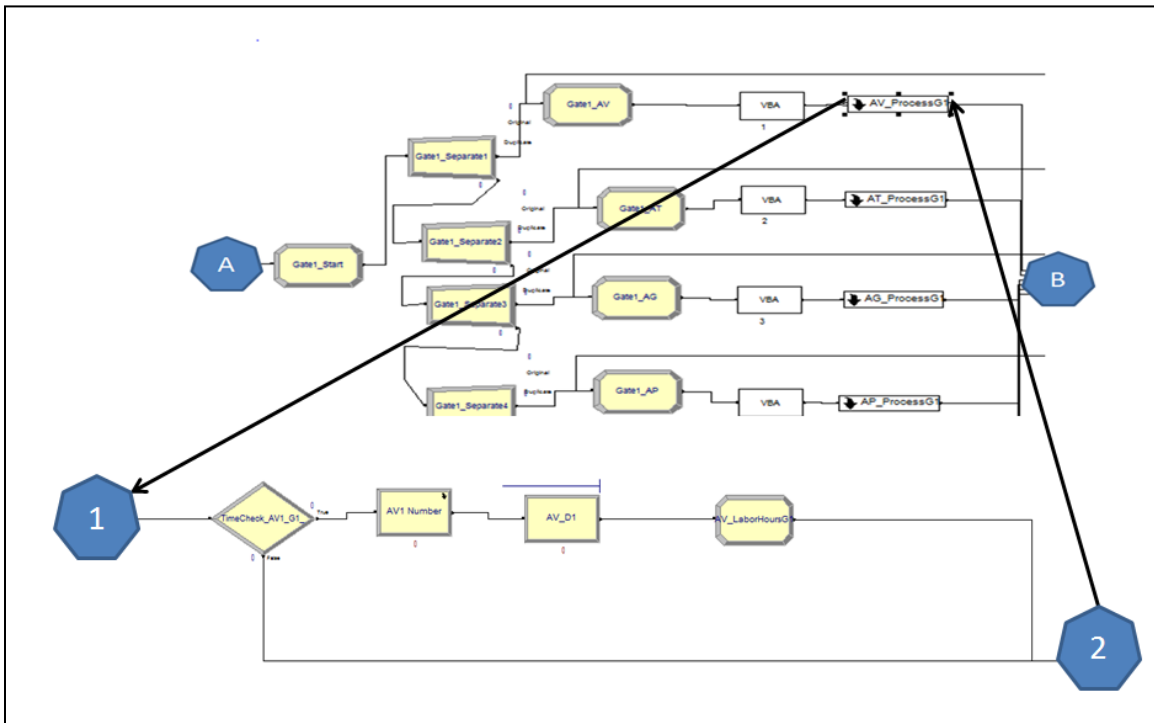


Figure 28: AV\_ProcessG1 (Gate 1 Sub Model)

The first step is deciding on whether the aircraft has maintenance requirements for the current flow day. The TimeCheck\_AV1\_G1 process decides if maintenance requirements exist on the aircraft for the day. If the ProcessTime attribute is greater than



allows aircraft held in the sub model to clear once personnel become available prior to the next aircraft initiating resource allocation decisions, preserving the first-in-first-out priority processing of the model. The aircraft then flows through several decision points in order to avoid allocating more personnel than SMEs defined as the maximum number of personnel that would be assigned.

The first step is to calculate the maximum number of personnel the aircraft needs for maintenance processing. The AVMinSeize1 module assigns the maximum number of personnel needed to complete the man-hour requirements in 1 shift (AVMinSeize attribute) using the function shown in Equation 13.

$$\text{MX}(1, \text{ANINT}(\text{ProcessTime} / (\text{OPMD} * \text{NumberofShifts}))) \quad (11)$$

The function uses the larger value of 1 or the rounded integer solution of ProcessTime divided by the product of OPMD and NumberofShifts. In review, the ProcessTime attribute is the maintenance hours required for the current flow day, the OPMD variable is the output per man-day of one employee in the model, and NumberofShifts is the constraint for the minimum number of shifts the man-hours for the day can be completed. Therefore, the AVMinSeize value is the maximum number of personnel required to complete the flow day's man-hour requirements without falling below the minimum time the aircraft should be in work each flow day as identified by SMEs. For example, if the aircraft requires 16 AV hours with an eight OPMD and one for NumberofShifts, the AVMinSeize value would be two. Following the AVMinSeize1 process the aircraft proceeds to the DecideAV\_Seize1 process.

The DecideAV\_Seize1 process directs the aircraft down one of two paths based on Equation 14. If the number of personnel available is less than the seize constraint identified by SMEs, the equation is true and the aircraft flows forward to the AV\_Available\_DecideMinSeize1 process. Otherwise, it is directed down the second path to the AV\_Constraint\_DecideMinSeize1 process.

$$AV\_Available \leq AV\_SeizeConstraint \quad (12)$$

In the AV\_Available\_DecideMinSeize1 process, if the AV\_MinSeize attribute is greater than or equal to the AV\_Available variable, Equation 15 is true and the aircraft flows to the AV\_NumberAvailableG1 process where it assigns the AV SeizeNum attribute with the AV\_Available value.

$$AVMinSeize \geq AV\_Available \quad (13)$$

If false, the aircraft proceeds to the AV\_Available\_MinConstraintG1 process where the AV SeizeNum attribute is assigned with the value of the AV\_MinSeize attribute previously assigned in the AV\_MinSeize1 process. This decision ensures that the AV SeizeNum value does not exceed the number of personnel currently available in the AV set (AV\_Available). The aircraft then flows to the AV\_SeizeReLoop1 decision process where, if the AV SeizeNum attribute is less than a variable called AVMinSeizeConstraint, Equation 16 is true and it is directed to a hold process (AV\_Hold1) until AV personnel become available. If false, the aircraft exits the AV1 Number sub model because enough personnel are available to start maintenance.

$$AVMinSeize < AVMinSeizeConstraint \quad (14)$$

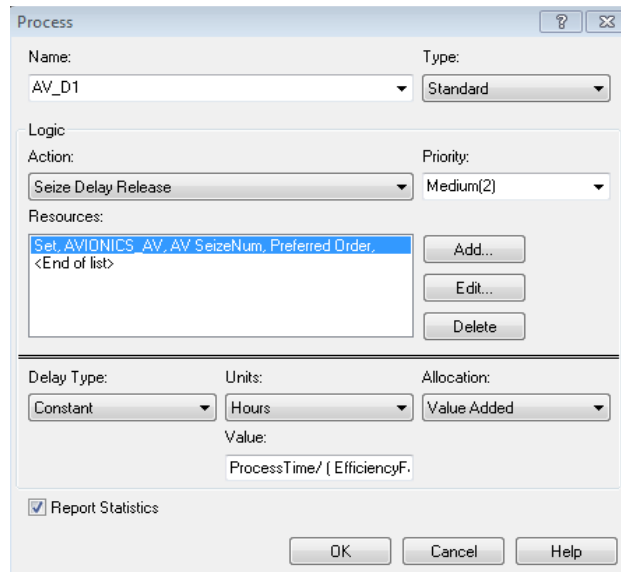
When the aircraft is directed down the second or false path from DecideAV\_Seize1 process, it proceeds to the AV\_Constraint\_DecideMinSeize1 process for a similar decision to the first path with differences only in the second variables used from Equation 14 to Equation 15. In this decision, if Equation 17 is true the aircraft flows to the AV\_ConstraintG1 and the AV SeizeNum attribute is assigned with a value equal to the AV\_SeizeConstraint variable. The AV\_SeizeConstraint variable is identified by SMEs as the maximum number of personnel from the AV specialty that are assigned at any point in time to work one aircraft in the real system. If Equation 17 is false, the aircraft is directed to the AV\_MinConstraintG1 process where the AV SeizeNum attribute is assigned with a value equal to the AVMinSeize attribute. The purpose of this decision is to ensure the AV SeizeNum is constrained to a maximum number based on SME inputs while still assigning the highest value possible. The aircraft exits the AV1 Number sub model once the AV SeizeNum is assigned and proceeds to the AV\_D1 process to complete maintenance requirements.

$$AVMinSeize \geq AVMinSeizeConstraint \quad (15)$$

### **AV\_D1 Process**

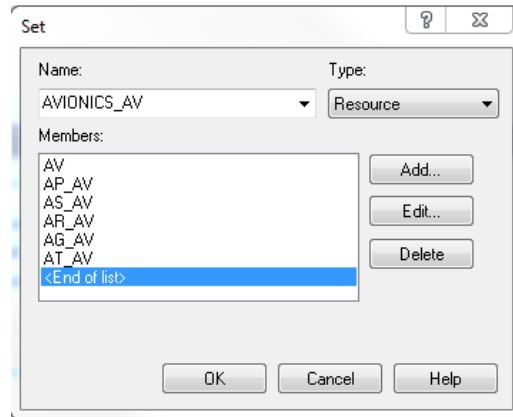
The AV\_D1 process is the heart of this simulation research. The aircraft flows into the process and is delayed while maintenance man-hour requirements are met for the day. This process and its sister processes in the other specialty paths are the only process modules that convert inputs into outputs within the system. The input is considered an aircraft with maintenance requirements and an output is considered an aircraft with all

maintenance man-hour requirements met. All other processes up to this point are used to assign attributes and variables to facilitate this process.



**Figure 30: AV\_D1 Process**

The process uses a standard type of module with a Seize Delay Release action and assigns resources by Set. The set name is AVIONICS\_AV and includes the AV resource and the five additional multi-skill resources. The quantity used is the AV SeizeNum attribute assigned in the AV1 Number sub model. The selection rule is Preferred Order and the order is set for all runs subsequent to the baseline run with the priority of first seizing resources that have lower utilization rates in the baseline outputs. The resource types in the set and selection rule order are depicted in Figure 31. The order uses the baseline model and focuses pairings to seize lower utilized resources first using the resource utilization rates. Identifying the quantity of resources (personnel) seized is a critical step before moving on to the calculation of the processing (delay) time value.



**Figure 31: AVIONICS\_AV Resource Set**

The amount of time the aircraft is delayed (processing time) is based the man-hours required for AV on the current flow day (ProcessTime), the number of personnel assigned to complete maintenance (AV SeizeNum), and an efficiency factor for the pool of resources used (EfficiencyFactorAV). Equation 7, from Chapter 3, depicts the function used to decide the value of the process delay.

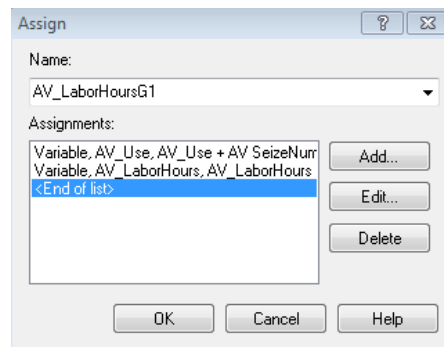
$$\text{ProcessTime} / (\text{EfficiencyFactorAV} * \text{AV SeizeNum}) \quad (7)$$

The efficiency factor is used to adjust the efficiency of the resource pool with multi-skilling. The initial value of the resource pool is one and can be adjusted down (.99, .98, etc.) to depict a loss in skill or efficiency. Levien (2010) multiplies processing times by a cross training factor in his multi-skill research on the KC-135 PDM process in order to emulate longer task durations associated with multi-skilled employees completing maintenance tasks. The efficiency factor in this research mathematically produces similar results by increasing task times as efficiency (task proficiency) decreases. However, multi-skilling an employee stipulates that the employee is fully qualified at the journeyman level on both skill sets (Federal Service Impasses Panel, 1997) and therefore equally proficient. The baseline model and experimental runs are

initially run with an efficiency factor of one. The analysis section of this chapter explains the sensitivity analysis methods used to gauge the impacts on model outputs of decreasing skill within the labor pool. Once the maintenance man-hours are met for the current flow day the aircraft is released and proceeds to the AV\_LaborHoursG1 module.

### AV\_LaborHoursG1

The AV\_LaborHoursG1 module assigns the two global variables, AV\_Use and AV\_LaborHours as depicted in Figure 32.



**Figure 32: AV\_LaborHoursG1**

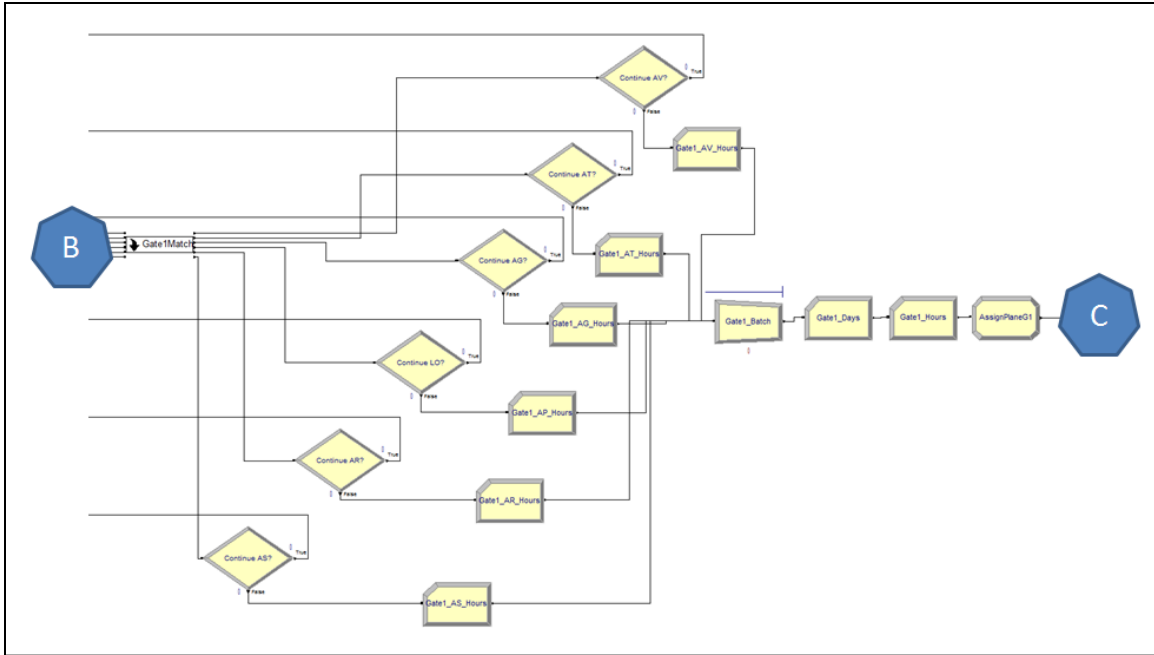
The global (system) trait of both variables is significant because the function acts like a tally of the number of AV technicians seized and the AV labor hours that are used in the system. Equation 18 defines the value assigned to the AV\_Use variable. The AV\_Use variable reflects the current global (system) value and the aircraft's current AV SeizeNum attribute value is added to the global (system) value of AV\_Use every time an aircraft passes through the module. The AV\_Use variable then reflects the total number of AV personnel seized up to that point within the system.

$$AV\_Use + AVSeizeNum \quad (16)$$

The AV\_LaborHours function is similar and tallies the total AV labor hours used by adding the ProcessTime attribute value of the aircraft passing through the module. The ProcessTime attribute value is the current flow day AV man-hours that were just completed in the AV\_D1 process. Equation 19 shows the value assigned to the AV\_LaborHours variable. Remember that each gate has a duplicate module with the same functions with each one concurrently adding to the global values of the variables. Additionally, each specialty path is the same and the variables are continuously calculated for each of the six specialties (AP\_Use, AP\_LaborHours, AS\_Use, AS\_LaborHours, etc.) in each of the seven gates. The aircraft exits the AV\_ProcessG1 submodel once the labor hours and number of personnel seized is recorded.

$$AV\_LaborHours + ProcessTime \quad (17)$$

The next few paragraphs discuss the last sub model and process modules in Gate 1 as depicted Figure 33.



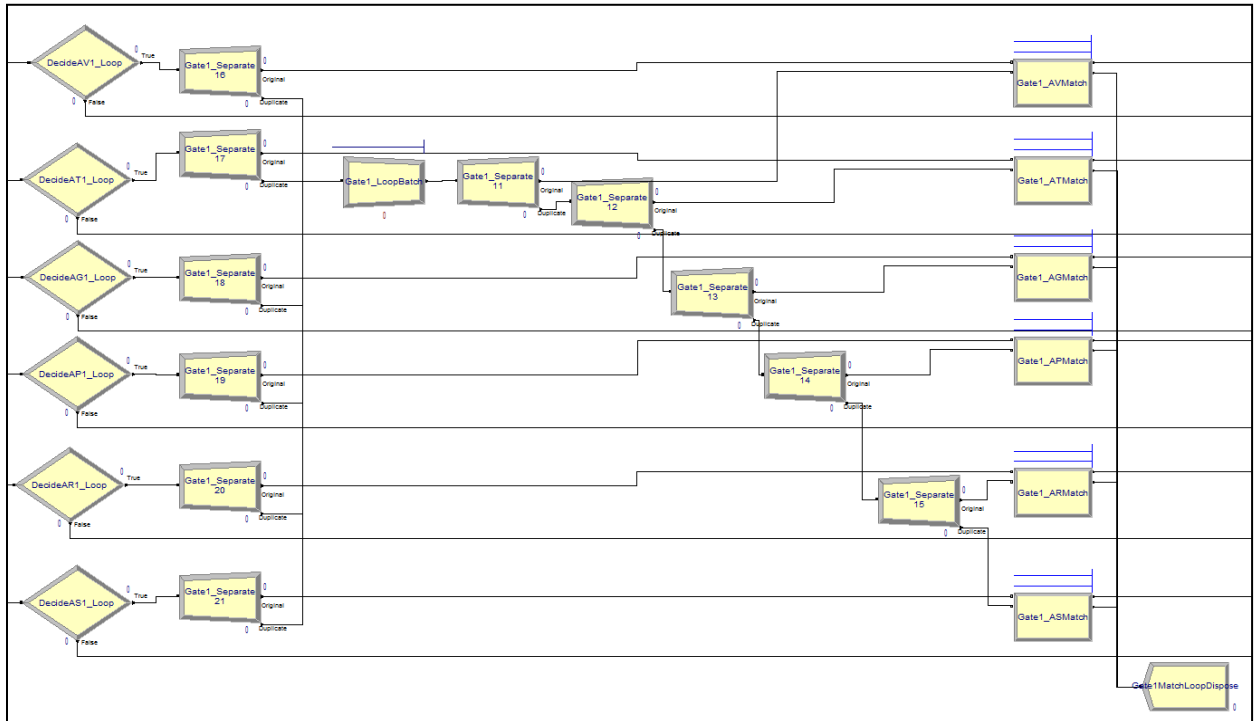
**Figure 33: Gate 1 Sub Model (b)**

In summary, the second half of the gate restrains or aligns the six identical aircraft in order to stay within a certain number of flow days of each other. It then re-loops the aircraft back to the beginning of the gate when the aircraft requires more flow days within the gate and combines the aircraft back into one entity before allowing it to exit the current gate. The mechanism aligning flow days by aircraft is the first process in the second half of the gate and occurs within the sub model Gate1Match.

### **Gate1Match**

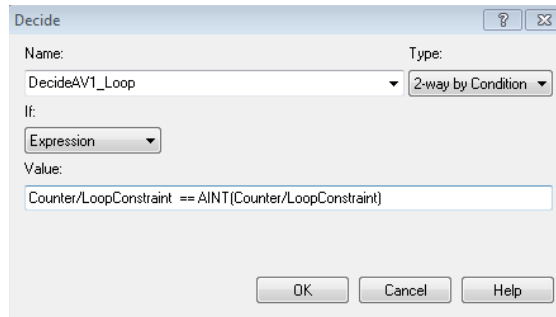
The first process in the second half of the gate is the Gate1Match sub model depicted in Figure 34. This process is important because it restricts the six duplicates of one aircraft to within a certain number of flow days of each other based on SME consultations. LoopConstraint is the variable created and used to reflect the SME defined constraint for how far ahead maintenance specialties can work from other specialties

working the same aircraft. Figure 34 shows all six identical specialty paths but the AV path equation is the only one described in detail for brevity purposes.



**Figure 34: Gate1Match**

The aircraft enters the sub model and enters the DecideAV1\_Loop where the decision is made on whether the aircraft needs to be realigned to the same flow day of its duplicates or whether it will bypass the subsequent matching functions. The DecideAV1\_Loop module's defined parameters are depicted in Figure 35.



**Figure 35: Decide AV1\_Loop**

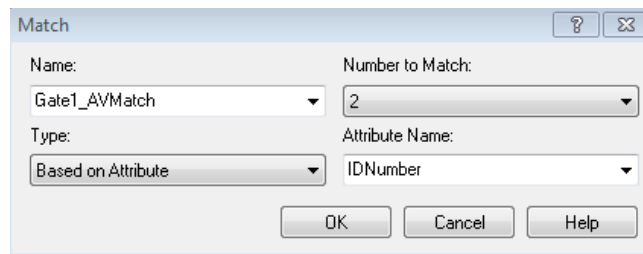
The parameters route the aircraft for matching when the Counter attribute divided by the LoopConstraint variable is equal to the truncated value of the same function. In order for Equation 20 to be true, the Counter divided by the LoopConstraint has to equal an integer value because the truncated value is always an integer. For example, if the Counter value is 6 and the LoopConstraint is 2, Equation 21 would be true because the quotient is an integer of 3. If the Counter value is 5 with the same LoopConstraint of 2, the equation would be false because the quotient of 2.5 does not equal the truncated quotient of 2. If the equation is false, the aircraft bypasses the matching function and exits the sub model. The aircraft that are routed for matching proceed to Gate1\_Separate16 module.

$$Counter / LoopConstraint == AINT(Counter / LoopConstraint) \quad (18)$$

The Gate1\_Separate16 module creates a duplicate of the aircraft and routes it to the Gate1\_LoopBatch module. The original flows down a separate path to the Gate1\_AVMatch module where it is held. The Gate1\_LoopBatch module holds the duplicate aircraft until the other five aircraft in the other specialty paths containing the same IDNumber attribute (assigned in Characteristics sub model) arrive. Remember that all six specialty paths are identical so the other five model specialty paths (AT, AG, AP,

AR, and AS) create a duplicate in the same way as AV. The batch function holding the entity until all six of the same IDNumber arrives realigns the duplicates to the same flow day. The separate but identical entities are batched together and allowed to proceed as one to the Gate1\_Separate11 module.

In the Gate1\_Separate11 module the entity is duplicated with the one of the duplicates flowing to the Gate1\_AVMatch module and the other duplicate proceeds to another Separate module. The duplicate entity that flows to the Gate1\_AVMatch module is matched to the original entity that is being held for matching with another entity with the same IDNumber. Figure 36 identifies the parameter values for matching in the Gate1\_AVMatch module.



**Figure 36: Gate1\_AVMatch**

Once an aircraft with the same IDNumber arrives, both aircraft are released and the original aircraft exits the sub model while the duplicate is routed to the Gate1MatchLoopDispose module for disposal. An important detail to highlight is that the original aircraft retains the same attributes that it entered the Gate1Match sub model with but the duplicate only retains the unique IDNumber because of the batching. This is important because the attribute values of the original must be retained for future use. The subsequent separate module and duplicate aircraft simultaneously repeat the process and then flow to another Separate module until all six have been reduplicated, matched, and

released. Functionally, this process realigns all six specialties' entities to the same flow day and does so every so many flow days as defined by the LoopConstraint. Once the flow days are realigned the entity flows out of the sub model to another decide module in Gate 1.

### ContinueAV? Module

The next decide module *Continue AV?* decides whether or not the entity has more flow day requirements in the current gate. The parameters displayed in Figure 37 re-loop the entities back to Gate1\_AV module if the ContinueFlag attribute is one. The aircraft then recompletes the Gate 1 AV path.

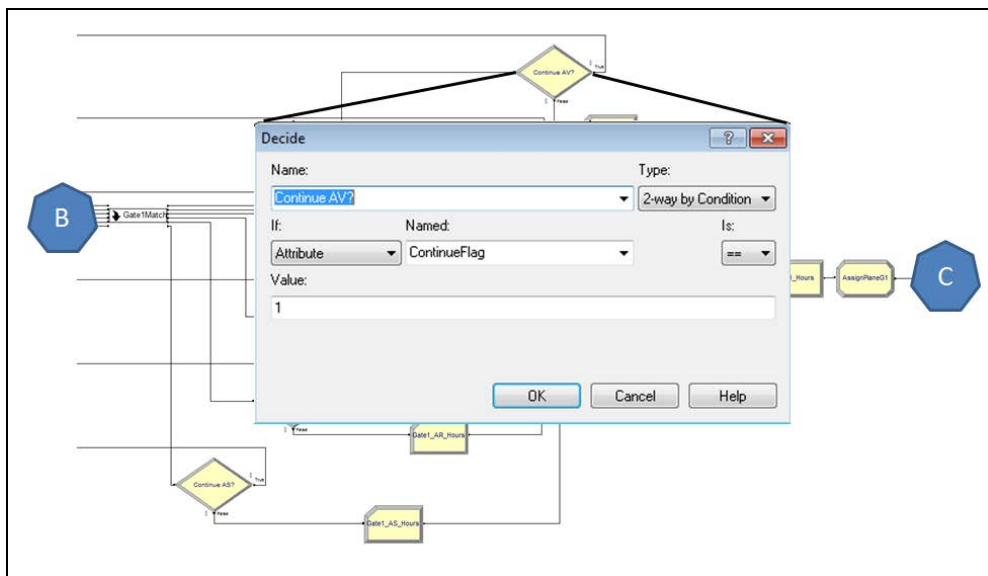
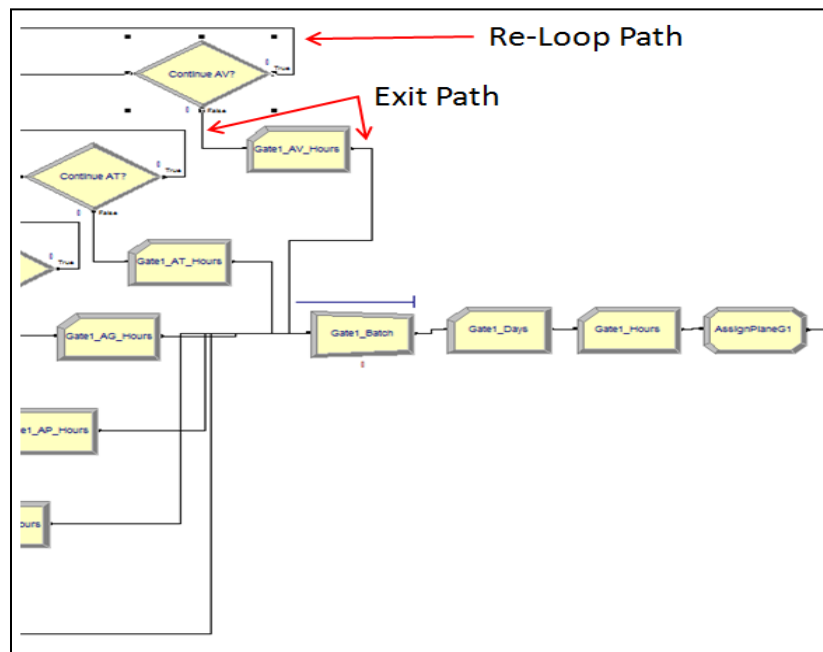


Figure 37: Continue AV?

Recall that the VBA block assigns a value of zero to the ContinueFlag if the next flow day is the start of the next gate. When the value is zero and the entity enters the Continue AV? module, the condition is false and the entity is directed to the exit path of the Gate 1 sub model.

## Gate 1 Exit Path

The exit path of each gate routes through five modules before exiting Gate 1. The modules include a batching module, three record modules, and an assign module as shown in Figure 38.



**Figure 38: Gate 1 AV Re-Loop and Exit Path**

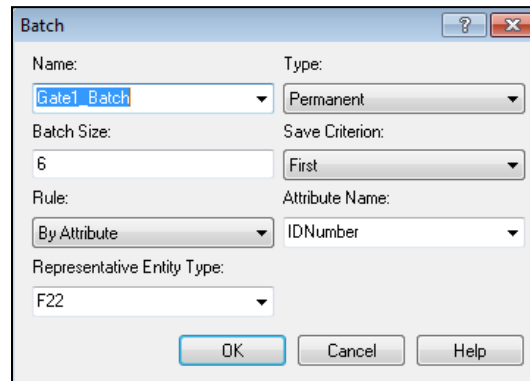
The first module on the exit path is the Gate1\_AV\_Hours record module with parameters depicted in Figure 39. It tallies the number of hours each entity spends in the Gate 1 AV path by subtracting the Gate1\_Begin attribute from the current time (TNOW).

The screenshot shows a 'Record' configuration dialog box. The 'Name' field is set to 'Gate1\_AV\_Hours' and the 'Type' is 'Expression'. The 'Value' field contains the expression 'TNOW - Gate1\_Begin'. There is an unchecked checkbox for 'Record into Set'. The 'Tally Name' field is also set to 'Gate1\_AV\_Hours'. At the bottom, there are 'OK', 'Cancel', and 'Help' buttons.

**Figure 39: Gate1\_AV\_Hours**

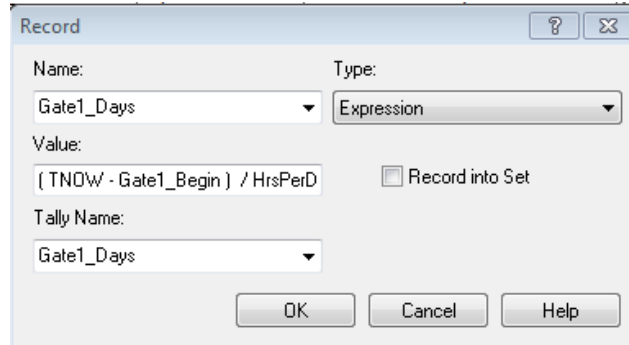
The value recorded and reported in output values is not used for this research because the Gate1Match sub model aligns the time spent in each path and in most cases the value will be the same for all six paths. However, if the LoopConstraint value in Gate1Match is given a high enough value, it will no longer be a constraint and the entities on the six paths with the same IDNumber will no longer be realigned to the same flow day.

Next, the entity flows to the Gate1\_Batch module and is held until the other five entities with the same IDNumber arrive. Then entities are combined back into one aircraft and it is released to the final two record modules and an assign module.



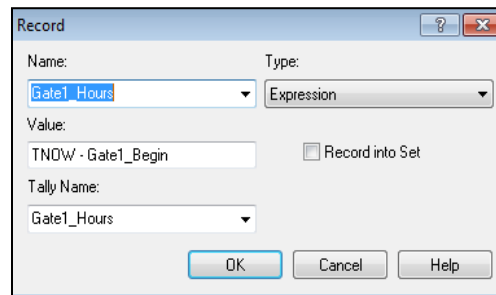
**Figure 40: Gate1\_Batch**

The final two record modules are used to tally the total days and the total hours the aircraft is in the gate. Gate1\_Days module records the number of days using the parameters depicted in Figure 41 dividing the difference of the current simulation time minus the gate start time by the HrsPerDay variable.



**Figure 41: Gate1\_Days**

Gate1\_Hours tallies the number of hours the aircraft spent in the gate using the parameters depicted in Figure 42, subtracting the gate start time by the current simulation time.



**Figure 42: Gate1\_Hours**

The aircraft is then assigned a plane picture in AssignPlaneG1 module and exits Gate1 and proceeds to Gate 2. There are a couple differences between Gate 1 and Gates 2 through 7 that need to be clearly defined in order to fully understand the functions and outputs of the model.

### **Gate Sub Model Differences**

In addition to the equation differences previously described, Gates 1-7 sub models contain small differences in the exit path in order to collect additional output statistics and also to reflect constraints and additional actions identified by SMEs. The following

paragraphs begin by identifying the modules used to collect additional statistics and then discuss unique modules and processes added in certain gates in order to accurately reflect the real system.

### Gate 2-7 Exit Path Differences

Gates 2 through 7 have an additional record module after the Gate#\_Hours module named Gate#\_Cumulative days. The # reflects the gate number the module resides. This module, with parameters shown in Figure 43, records the total flow days the aircraft is in the system by taking the difference of current simulation time (TNOW) minus the ArrivalTime attribute and dividing it by the HoursPerDay variable. This statistic shows the time it takes for an aircraft, in total cumulative days, to meet the maintenance requirements through each gate. For example, the Gate2\_CumulativeDays value shows how long an aircraft takes to get from the start of Gate 1 to the finish of Gate 2.

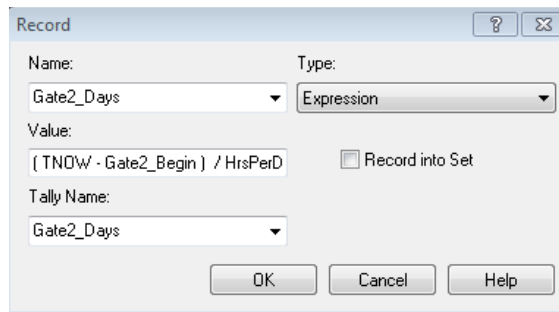
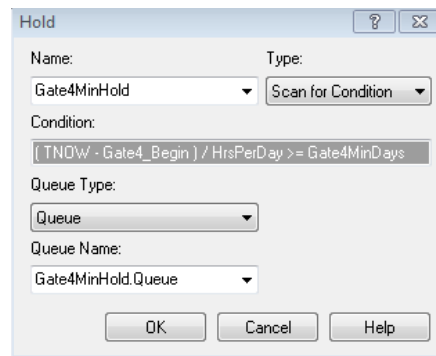


Figure 43: Gate2\_CumulativeDays

### Gate 4 Differences

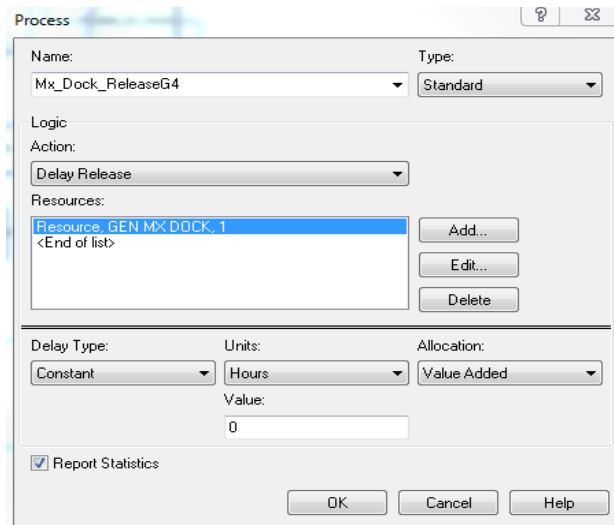
Gates 4 has two additional modules in the exit path. The first additional module, Gate4MinHold, is used to hold the aircraft in Gate 4 until it meets the 12 day constraint identified by SMEs as the minimum number of days it takes to complete the gate. The

constraint is given a variable name Gate4MinDays with a value of 12. A variable is used for ease of adjustment to the value. Specialties outside of the six considered in this research complete a majority of the work and SMEs identified that the maintenance hour requirements do not reflect the time it takes the aircraft to complete the gate. Figure 44 shows the parameters and equation used in Gate4MinHold to hold and release the aircraft.



**Figure 44: Gate4MinHold**

The second additional module, Mx\_Dock\_ReleaseG4, releases the general maintenance dock seized in the Characteristics sub model using the parameters depicted in Figure 45.



**Figure 45: Mx\_Dock\_ReleaseG4**

### **Gate 5 & 6 Differences**

Gate 5 and 6 contain the seize and release modules for LO docks, reflecting the aircraft being moved into low observable maintenance (LO) at the beginning of Gate 5 and exiting LO maintenance at the end of Gate 6. The LO\_Dock\_SeizeG5 module is the first process in Gate 5 and seizes an LO dock. The LO\_Dock\_ReleaseG6 module is the last process in Gate 6 and uses the same function as the seize function in Gate 5 except it releases the LO dock in the Action preference. The last of the differences within the gates is seen in Gate 7.

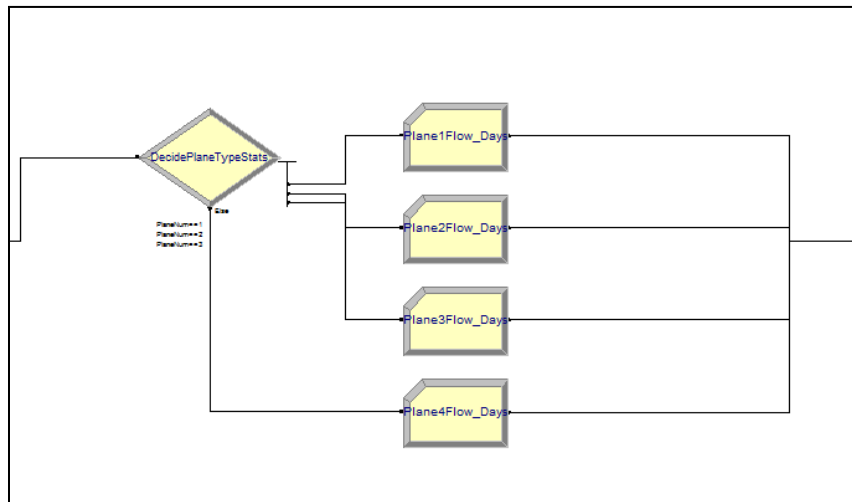
### **Gate 7 Differences**

Gate 7 is shown in Appendix A and contains several minor differences from the Gate 1 description. The differences start with the Mx\_Dock\_SeizeGate7 module, the first process within the gate. It seizes a general maintenance dock in the same way the Mx\_Dock\_Seize1 module does at the end of the Characteristics sub model. A similar

difference occurs at the end of Gate 7 with the Mx\_Dock\_ReleaseGate7 module, where the aircraft releases the general maintenance dock.

The completed aircraft then flows through the Flow\_Days record module to tally the final flow day value. This value is reported in the output statistics and reflects the average flow days needed to complete an aircraft. Next, the Depot\_Exit\_Count record module counts the aircraft. The depot exit count reflects aircraft throughput for the model run. The Flow\_Days and Depot\_Exit\_Count outputs are the most significant outputs for this research. Following the calculation of these values the aircraft proceeds to the final difference between Gate 7 and the other gates, the PlaneTypeStats sub model.

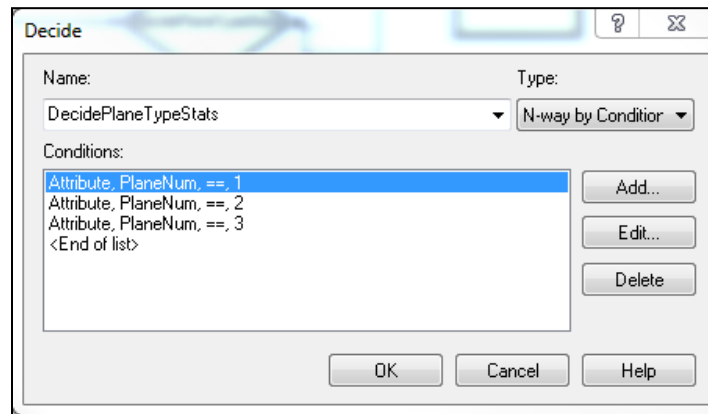
The PlaneTypeStats sub model shown in Figure 46 is the final process prior to the F-22 departing from the depot. The function of this sub model is to tally the number of flow days of each of the four types of aircraft that flow through the depot.



**Figure 46: PlaneTypeStats Sub Model**

First, the aircraft is directed down the path corresponding to the type of aircraft it is using the DecidePlaneTypeStats module. The decision is based on the PlaneNum

attribute and directs the aircraft down one of four paths using the parameters shown in Figure 47.



**Figure 47: DecidePlaneTypeStats**

Then the aircraft flows through one of the Plane#Flow\_Days record modules based on the path it is directed down. The flow days are calculated in the same way as previous flow day record module with the difference being that the outputs are based on the type of plane and not all plane types. This is important because this sub model creates flow day outputs based on the aircraft type and will provide valuable insights into the differences in average flow days based on the man-hour requirements of the aircraft. Once the values are recorded the aircraft exits Gate 7 and departs the system by flowing into the Depart disposal module.

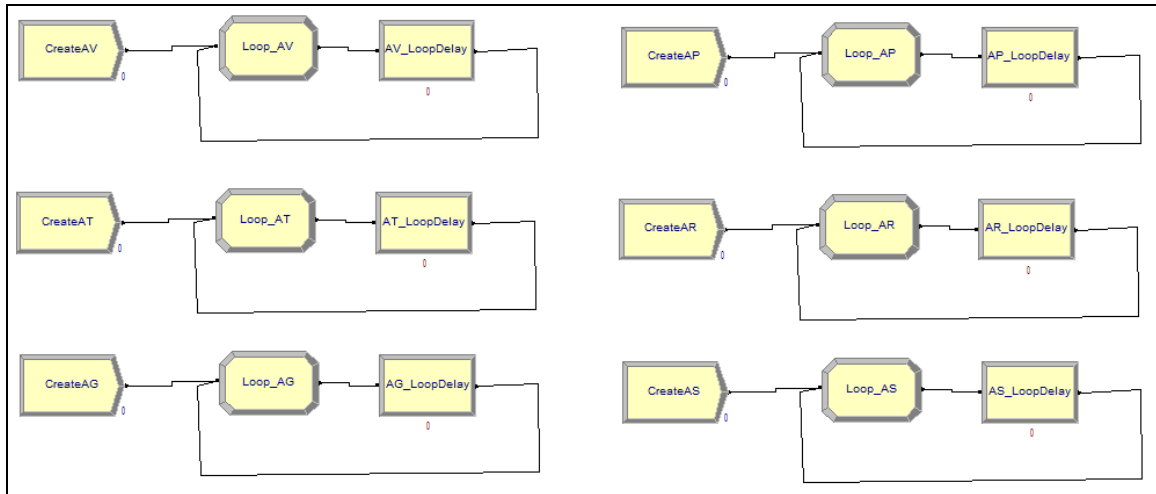
The model of an aircraft flowing through the F-22 Heavy Maintenance Modification Program is discussed in the previous sections with a focus on the process of transforming an input aircraft into a finished output aircraft. Over the next two sections I discuss the ten separate models that continually calculate global variable values and to record the final values of the statistics and global variables of interest for this study.

These separate models fall into one of two categories, either set availability calculation models or final value record models.

### **Set Availability Calculation Models**

In a discrete-event simulation the model is event driven and the simulation time proceeds from one event to the next. This characteristic presents a problem in this research due to the way the way the model is designed to hold during the AV1Number sub model. The hold function does not create an event to show when the hold condition is met and the global variable values will only change from one event to the next or when an entity is assigned a global variable value (AV\_Available, AT\_Available, etc.). This creates the need for a model that has an event to recalculate the global variable value at a certain interval.

Figure 48 depicts the six models that are built to recalculate the global (system) variable values for each of the six FWS specialties sets (COATER\_AP, SHEET\_METAL\_AS, AVIONICS\_AV, etc.). This grouping of models is hidden under Gate 1 to keep the Top Level Model as visually simple as possible. The naming convention corresponds to the variable that is being calculated and the corresponding set to which it is used. The next paragraph details the specifications of the AV model but the others are identical with the exception of the variable being calculated.



**Figure 48: Set Availability Calculation Models**

The AV model creates one entity at the start of the simulation run and the entity loops through the model for the entirety of the run. Upon creation the entity flows through the Loop\_AV module and is assigned the global variable AV\_Available in the same way it is assigned in the Gate1\_AV module at the start of Gate 1's AV path. Assigning this variable causes the variable to be recalculated each time the entity flows through the module.

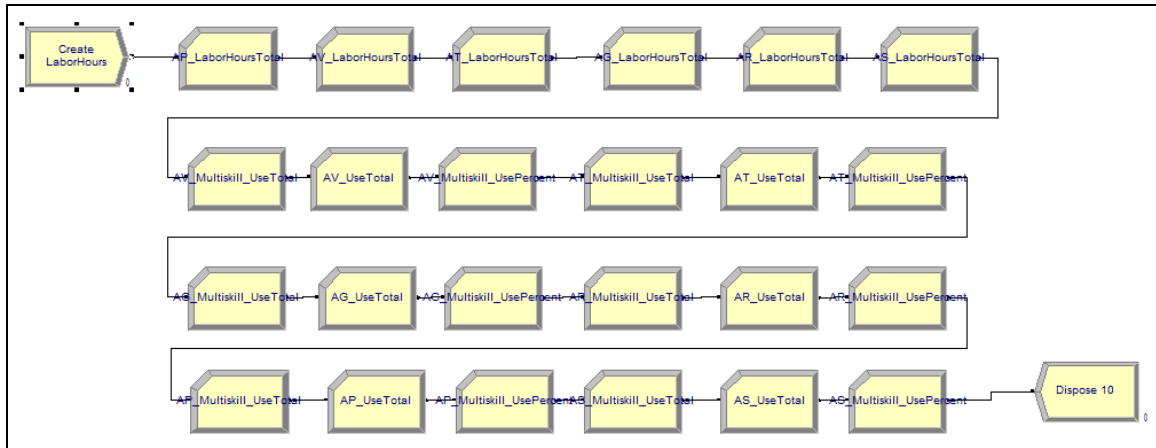
After the current value for AV\_Available is assigned / recalculated the entity proceeds to the AV\_LoopDelay module and is delayed for a number of hours based on the variable AvailabilityLoopDelay. The same variable is used for all six models so the delay is consistent within each. The value input for the AvailabilityLoopDelay is one hour so that every hour the entity is released and the AV\_Available variable value is recalculated. Functionally the model creates an event every hour to recalculate the global variables used for set availability values and allows for the hold functions used in the resource allocation sub models (AV1 Number, AV2 Number, etc.) to release the entities when personnel become available. The final discussion points in the Model Description

section of this chapter are the models created to calculate the final values of variables of interest and statistics derived from those values.

### **Final Value Record Models**

The built in statistics in ARENA 14® are used to calculate the final record module statistics associated with the main system model but these statistics do not encapsulate the entirety of outputs desired. Additional outputs desired include the total labor hours used by specialty, the total number of times a specialty was used (number of seizures), the number of times multi-skilled personnel are used, and the percentage of the time multi-skilled personnel are used versus the original labor pool. The following paragraphs discuss the model built to create and calculate these outputs.

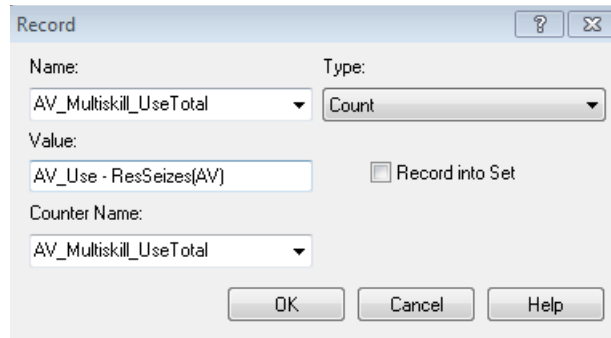
The model creates one entity at the final simulation time (TFIN), flowing the entity through four record modules per FWS specialty totaling 24 modules as shown in Figure 49. The four AV modules are described in detail for brevity and consistency purposes. The four modules include AV\_LaborHoursTotal, AV\_Multi-skill\_UseTotal, AV\_UseTotal, and AV\_Multi-skill\_UsePercent. The other specialties' modules contain identical equations except for the unique specialty variables used.



**Figure 49: Final Value Record Model**

The AV\_LaborHoursTotal module simply tallies the final value of the AV\_LaborHours function. The corresponding output value represents the total number of on aircraft (direct) labor hours used for the AV specialty during the simulation run. The AV\_UseTotal module records the final value of the AV\_Use variable and reflects the total number of AV resource seized during the simulation run to complete maintenance actions. The final two outputs generated involve calculating multi-skill use.

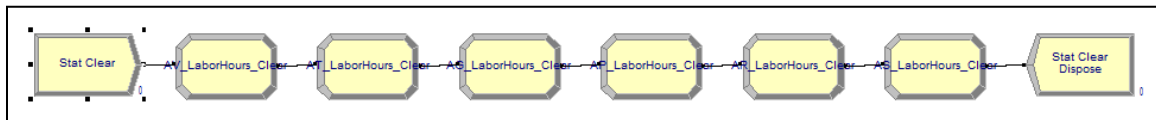
The AV\_Multi-skillUseTotal calculates the number of instances when a multi-skilled resource (technician) is seized to complete a maintenance requirement instead of the primary specialty. The output value reflects the AV\_Use variable minus the number of times the primary AV resource was seized (ResSeizes(AV)). Refer to Figure 49 for the parameters used within the module.



**Figure 50: AV\_Multi-skill\_UseTotal**

The AV\_Multi-skill\_UsePercent module uses the AV\_Multi-skill\_UseTotal value function and divides it by the AV\_Use variable to get the AV\_Multi-skill\_UsePercent output value. The percentage that multi-skill resources are utilized outside of their primary specialty is important because of the 25% threshold dictated by OPM as the minimum amount of time multi-trade personnel have to be used in the secondary skill (Office of Personnel Management, n.d.).

ARENA clears its internal statistics after the warm-up period of the simulation but the variable values created for this research are not cleared in the same way. The model shown in Figure 51 is created to clear the statistics at the end of the warm-up period. It creates one entity at the warm-up period prescribed in validation and flows through modules that set the global variable values back to zero. After resetting the values back to zero the entity is eliminated from the model via a dispose module.



**Figure 51: Statistic Reset Model**

This concludes the full description of the model developed for this research.

Additional figures and tables follow to support the methodology in Chapter 3 and the model developed.

	1B	2A	2B	2C	2D	2E	2F	2G	2H	2I	3A	3B	3C	3D	3E	3F	3G	3H	3I	3J	3K	3L	3M	3N	3O
A/C 0000 1A	0	0	0	0	0	0	0	0	0	0	0	0	0	0	0	0	0	0	0	0	0	0	0	0	0
3B	0	0	0	0	0	0	0	0	0	0	0	0	0	0	0	0	0	0	0	0	0	0	0	0	0
A2	0	0	0	0	0	0	0	0	0	0	0	0	0	0	0	0	0.5	0	0	0	0	0	0	0	0
A4	0	0	0	0	0	0	0	0	0	0	0	0	0	0	0	0	0	0	0	0	0	0	0	0	0
AC	0	15.5	0	0	0	0	0	0	0	1.5	0	0	0	0	0	0	0	0	0	0	0	0	0	0	0
AD	0	0	0	0	0	0	0	0	0	0	0	0	0	0	0	0	0	0	0	0	0	0	0	0	0
AF	5	28.7	0	0	0	0	0	0	0	0	0	0	0	0	0	0	0	0	0	0	0	0	0	0	0
AG	0	0	159.2	31.8	34.5	48	65.10001	12.6	29.5	25.2	16.4	2.2	11	19.1	10.3	43.2	33.1	61.4	2.3	0	0	63	0	0	0
AI	43.3	11.2	8	0	0	1	0	0	0	0	0	0	0	0	0	0	0	0	0	0	0	0	0	0	0
AP	42	20	54	0	0	0	24	50	4	0	0	5	0	0	38	40	0	9	0	0	12	0	4	0	64
AR	0	7.1	5.6	4.8	1.2	4	6.2	42.60001	19.8	9.799999	14.8	1	0	1.2	0	42.7	43.4	36	4	16.6	2	2	0	0	0
AS	0	0	166	163.4	256.6	63	79.20001	113.1	97	57	49	70	55.5	68	36	38	16	35.6	52.4	36.6	0	37	28.5	2.5	0.6
AT	0	0	0	0	38.2	80	0	4	32.1	24.6	4	0	0	2.5	26.4	20.8	0	0	0	0	0	0	0	0	0
AX	0	0	0	0	0	0	0	0	0	0	0	0	0	0	0	0	0	0	0	0	0	0	0	0	0
BE	0	0	0	0	0	0	0	0	0	0	0	0	0	0	0	0	0	0	0	0	0	0	0	0	0
DD	9	0	0	0	0	0	0	0	0	0	0	0	0	0	0	0	0	0	0	0	0	0	0	0	0
DN	0	0	8	0	0	0	0	0	0	0	0	0	0	4	0	2	0	2	0	5	0	5	2	0	5
EF	0	0	0	0	0	0	0	0	0	0	0	0	0	0	0	0	0	0	0	0	22	36	18	0	0
FA	0	0	0	0	0	0	0	0	0	0	0	0	0	0	0	0	0	0	0	0	0	0	0	0	0
IM	0	0	0	0	0	0	0	0	0	0	0	0	0	0	0	0	0	0	0	0	0	0	0	0	0
JN	0	0	0	0	0	0	0	0	0	0	0	0	0	0	0	0	10	11	8.5	11	8.5	20.5	16.5	8.5	6
XB	0	0	0	12.7	0	1	0	0	0	0	0	0	0	0	0	0	0	0	0	0	0	0	0	0	0
YB	0	0	0	0	0	0	0	0	0	0	0	0	0	0	0	0	0	0	0	0	0	0	0	0	0

Figure 52: Clemson Scheduling Tool (MORS) Example

## Appendix B- Validation Data

### Flow Day Validation

**Table 19: Current State Validation**

<b>Current State Validation: Expected vs Model Flow Days</b>					
<b>Aircraft Category</b>	<b>Man-Hour Requirement</b>	<b>Expected Non-OT Days</b>	<b>Model Output</b>	<b>Delta</b>	<b>% Delta</b>
Plane 1	20471.60	144.60	141.92	-2.68	-1.86%
Plane 2	20127.10	142.17	141.69	-0.48	-0.34%
Plane 3	19900.60	140.57	138.80	-1.77	-1.26%
Plane 4	15663.10	110.64	121.69	11.05	9.99%
<b>Avg Aircraft</b>	18617.06	<b>131.50</b>	<b>133.99</b>	<b>2.49</b>	<b>1.89%</b>
Average Aircraft Flow Days 95% Confidence Interval		Lower 95% CI	133.01	Upper 95% CI	134.97

**Table 20: Future State Validation**

<b>Future State Validation: Expected vs Model Flow Days</b>					
<b>Aircraft Category</b>	<b>Man-Hour Requirement</b>	<b>Expected Non-OT Days</b>	<b>Model Output</b>	<b>Delta</b>	<b>% Delta</b>
Plane 1	20471.60	144.60	127.77	-16.83	-11.64%
Plane 2	20127.10	142.17	127.42	-14.75	-10.38%
Plane 3	19900.60	140.57	123.81	-16.76	-11.92%
Plane 4	15663.10	110.64	109.67	-0.97	-0.88%
<b>Avg Aircraft</b>	19384.41	<b>136.92</b>	<b>123.33</b>	<b>-13.59</b>	<b>-9.93%</b>
Average Aircraft Flow Days 95% Confidence Interval		Lower 95% CI	122.75	Upper 95% CI	123.91

## Appendix C- Analysis Results

### Current State- Manpower Add

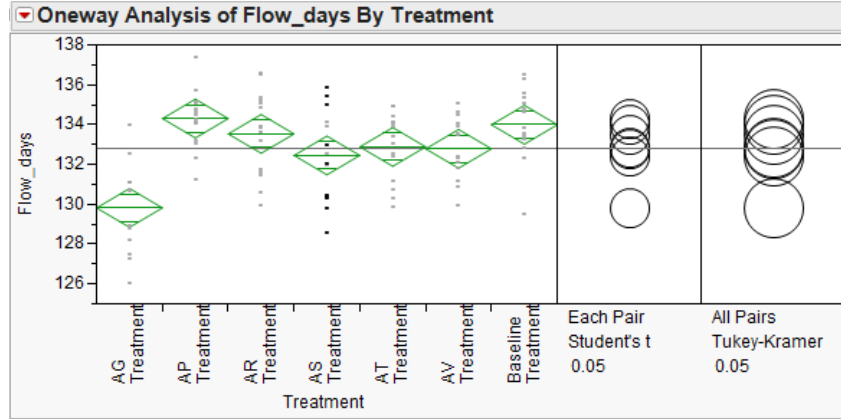


Figure 53: Manpower Current State - Experiment A1 JMP® ANOVA

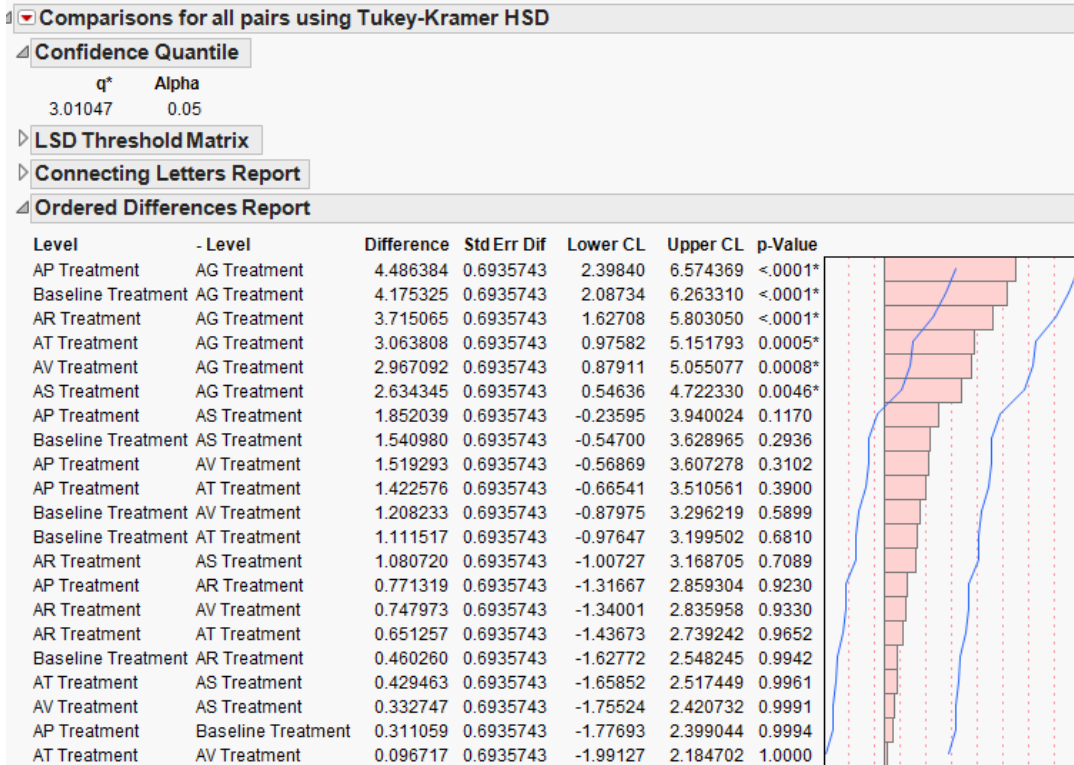


Figure 54: Manpower Current State - Experiment A1 JMP® Tukey-Kramer HSD

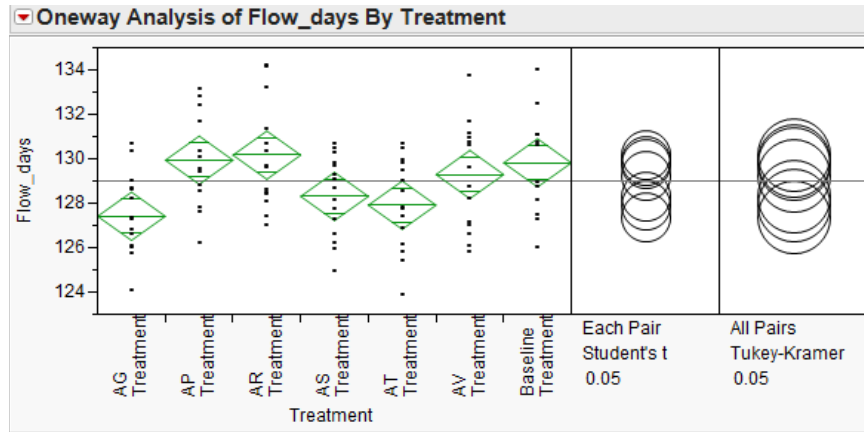


Figure 55: Manpower Experiment A2 JMP® ANOVA

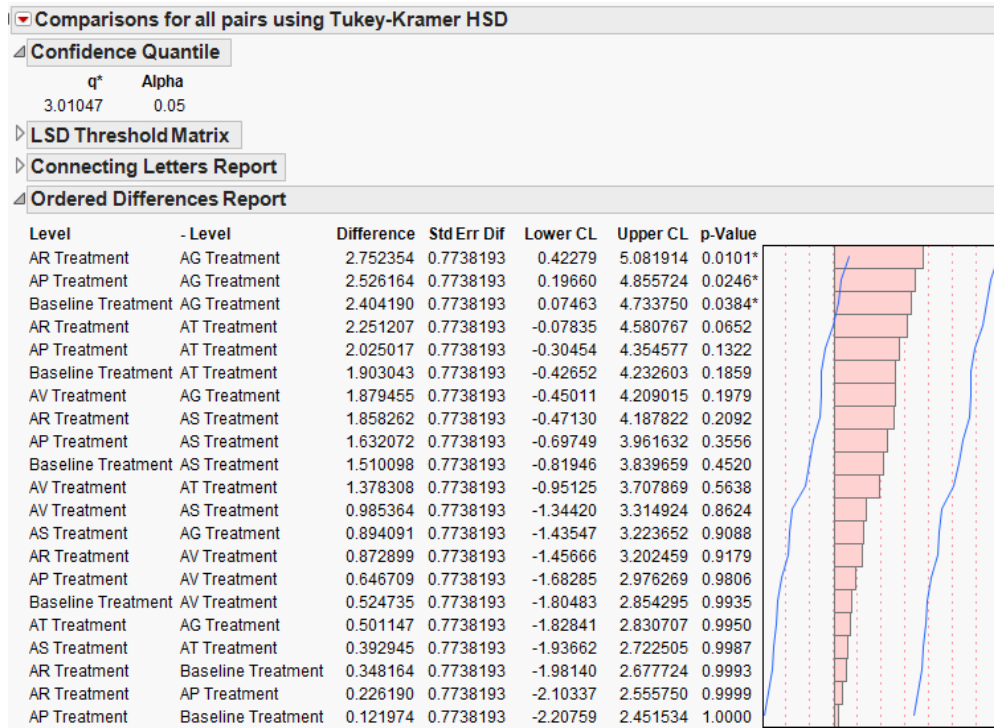


Figure 56: Manpower Current State - Experiment A2 JMP® Tukey-Kramer HSD

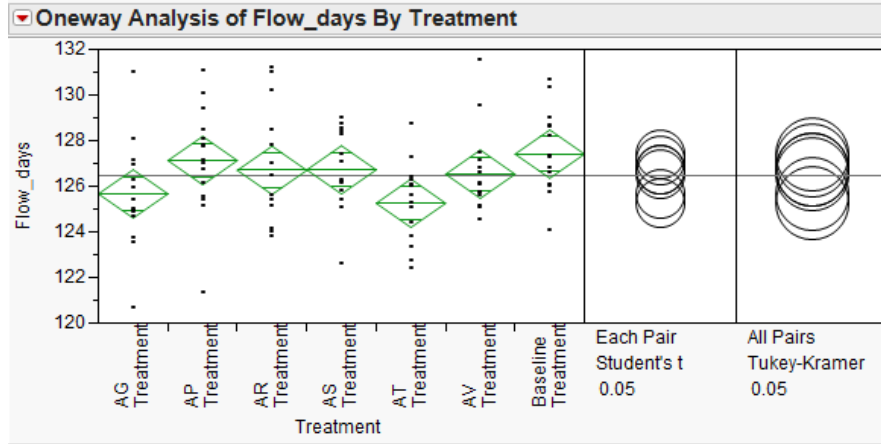


Figure 57: Manpower Current State - Experiment A3 JMP® ANOVA

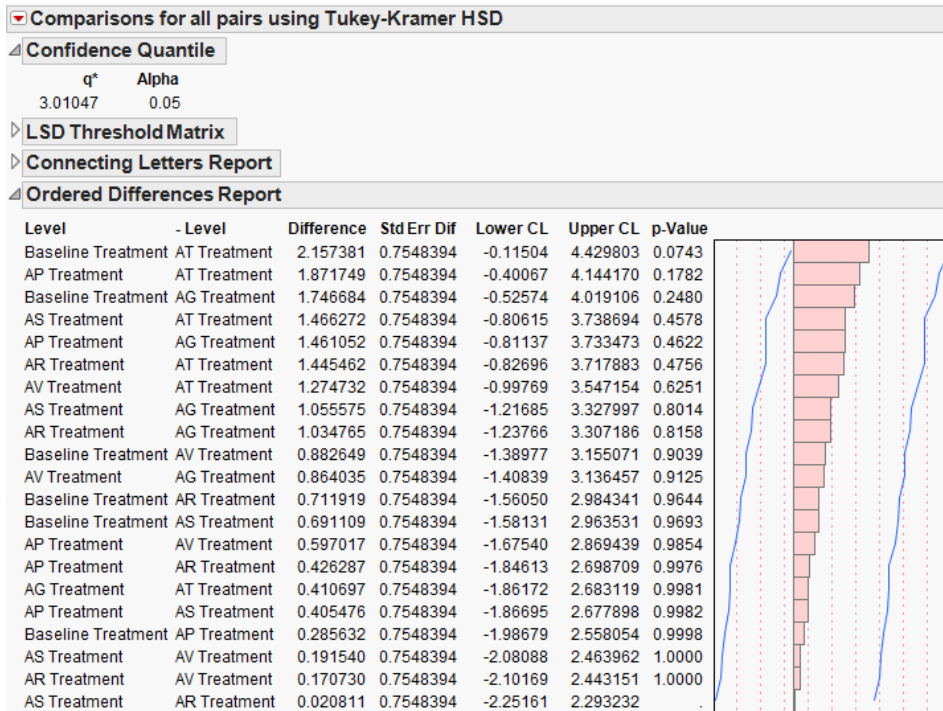


Figure 58: Manpower Current State - Experiment A3 JMP® Tukey-Kramer HSD

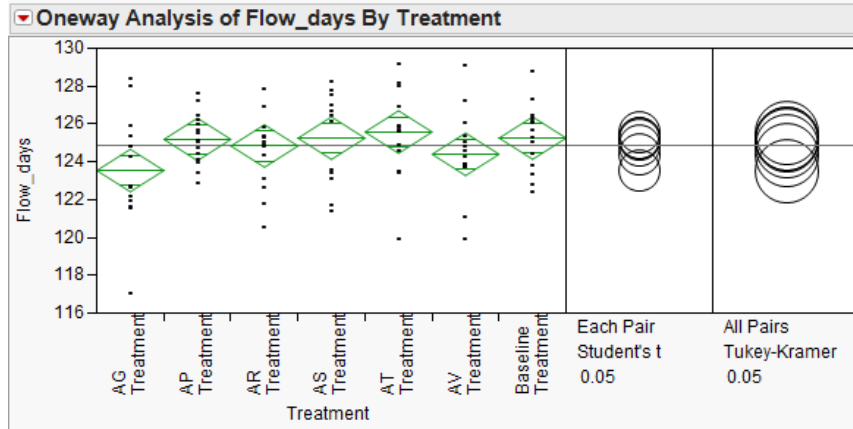


Figure 59: Manpower Current State - Experiment A4 JMP® ANOVA

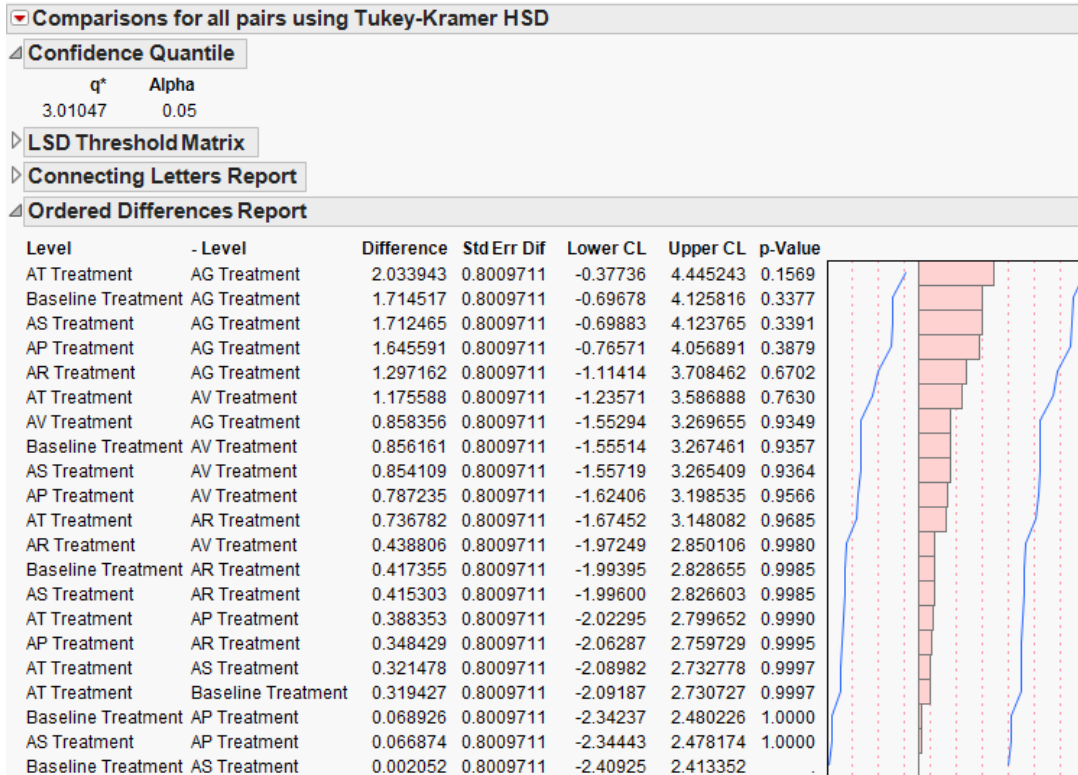


Figure 60: Manpower Current State - Experiment A4 JMP® Tukey-Kramer HSD

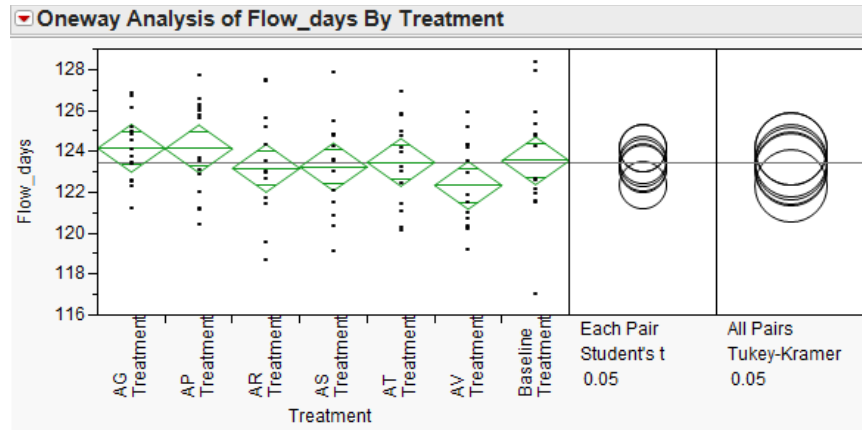


Figure 61: Manpower Current State - Experiment A5 JMP® ANOVA

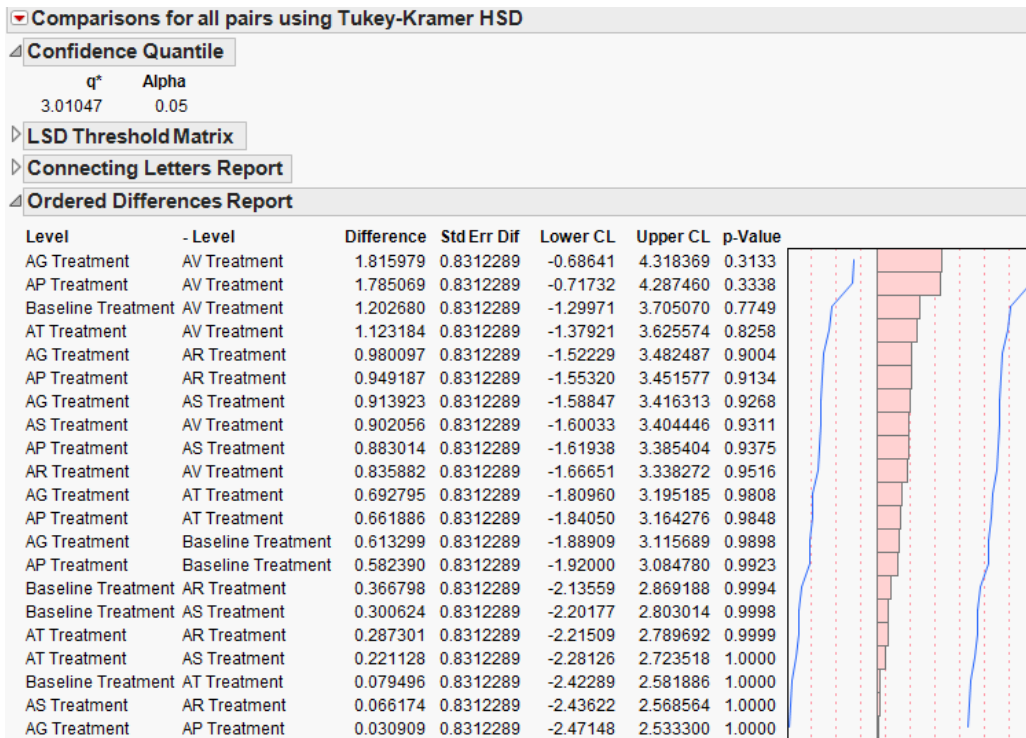


Figure 62: Manpower Current State - Experiment A5 JMP® Tukey-Kramer HSD

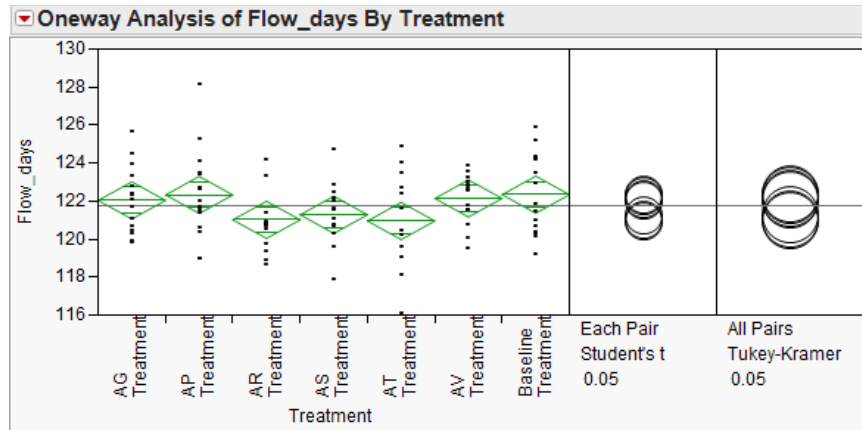


Figure 63: Manpower Current State - Experiment A6 JMP® ANOVA

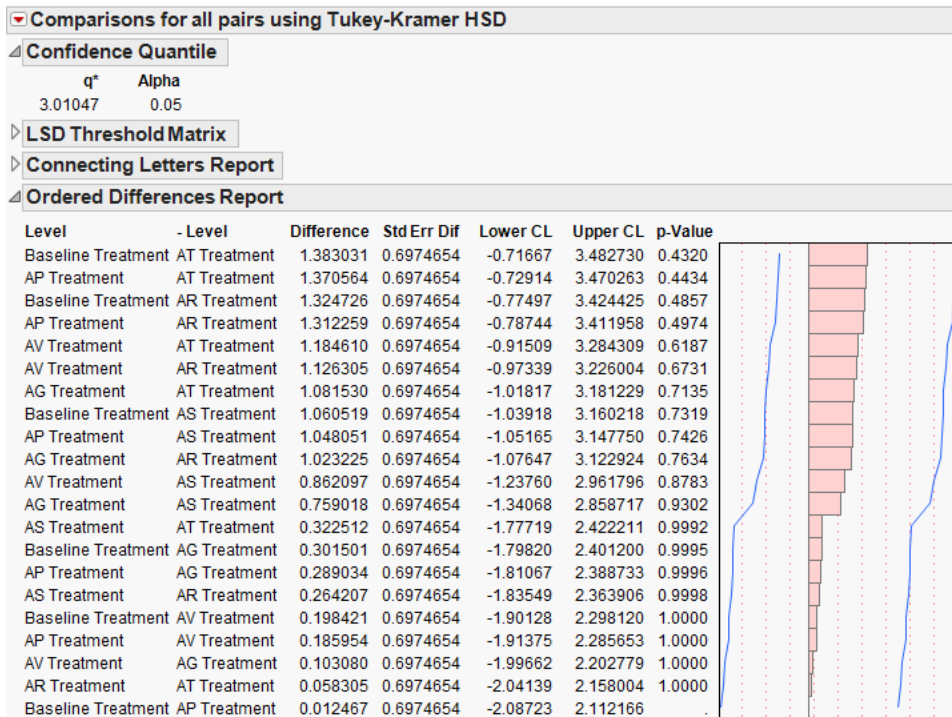


Figure 64: Manpower Current State - Experiment A6 JMP® Tukey-Kramer HSD

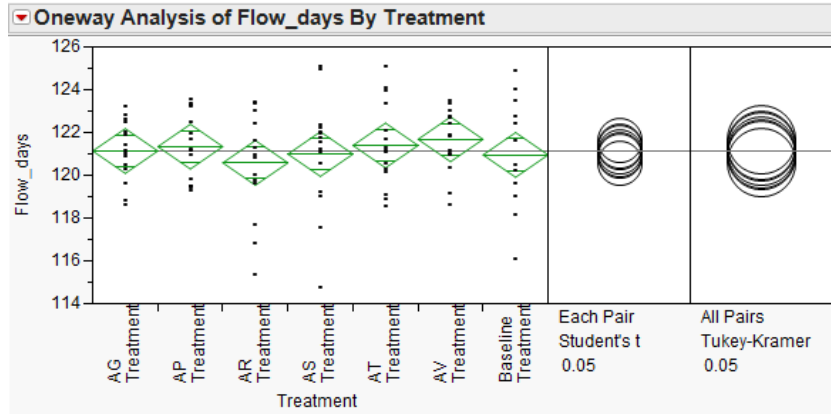


Figure 65: Manpower Current State - Experiment A7 JMP® ANOVA

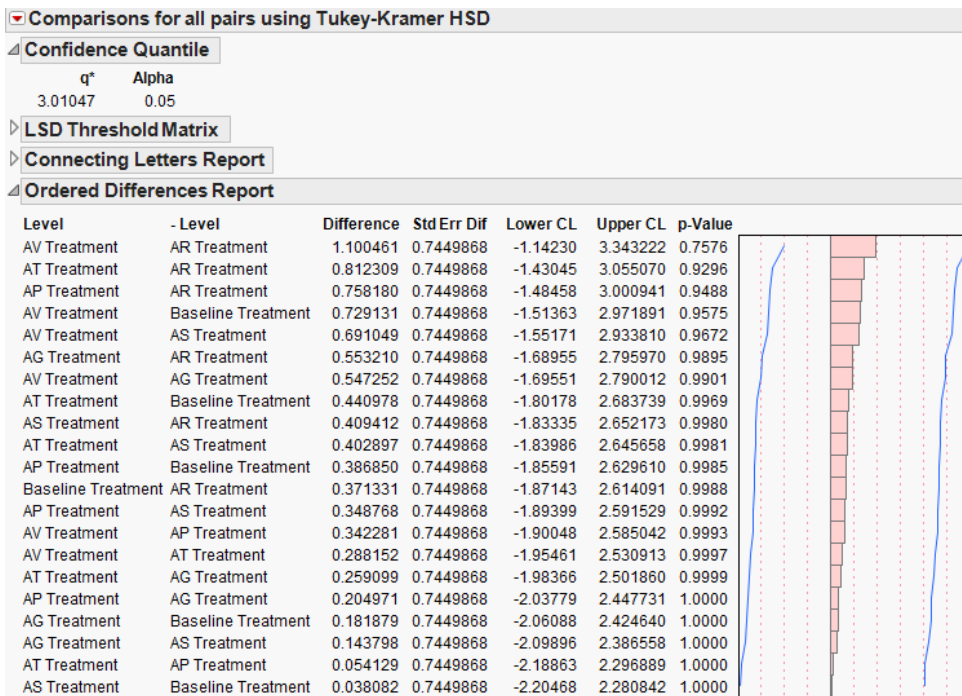


Figure 66: Manpower Current State - Experiment A7 JMP® Tukey-Kramer HSD

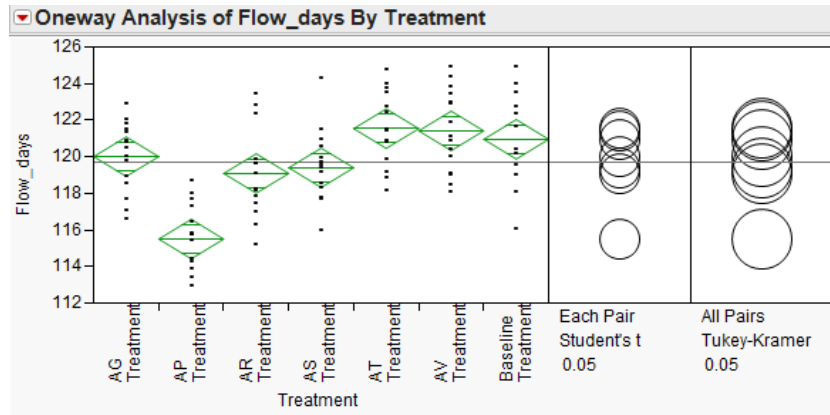


Figure 67: Manpower Current State - Experiment A8 JMP® ANOVA

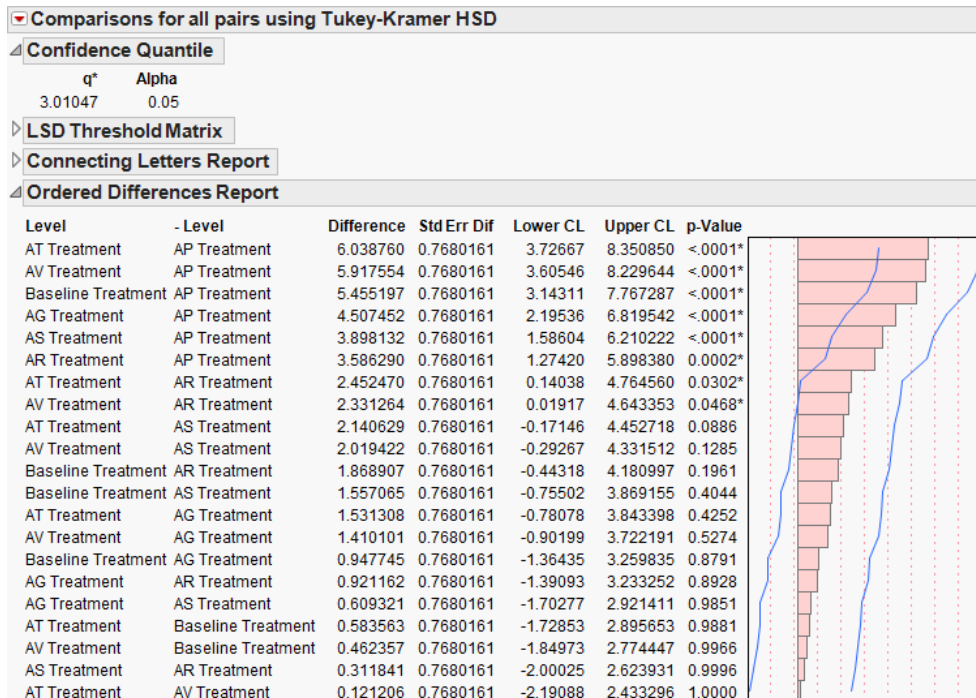


Figure 68: Manpower Current State - Experiment A8 JMP® Tukey-Kramer HSD

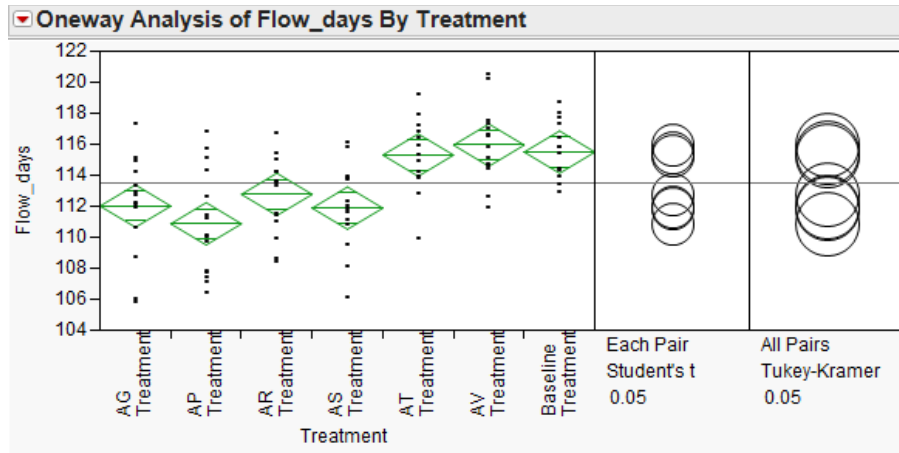


Figure 69: Manpower Current State - Experiment A9 JMP® ANOVA

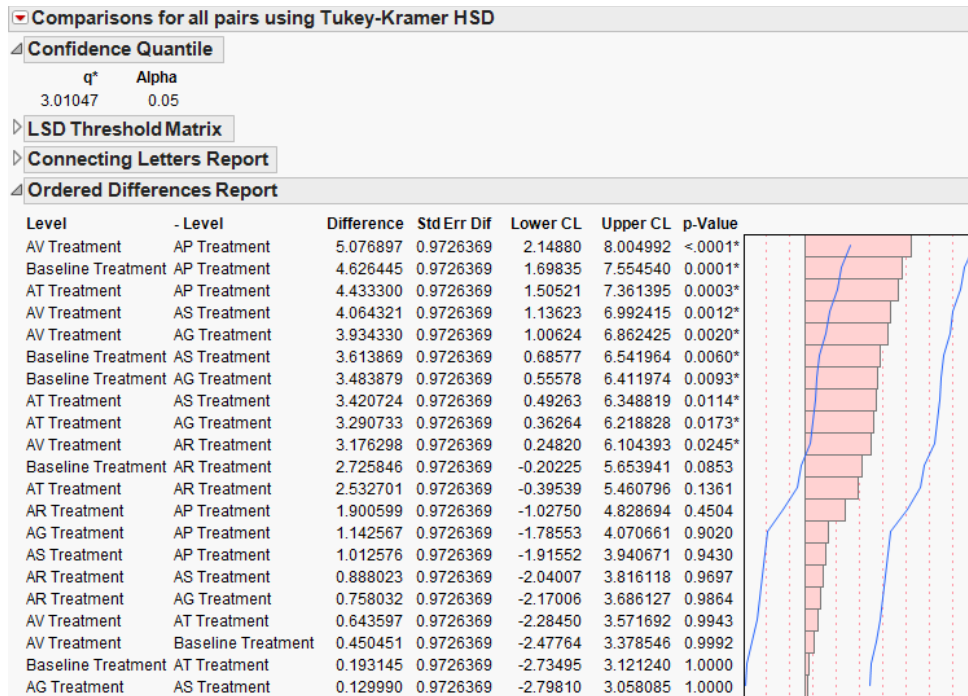


Figure 70: Manpower Current State - Experiment A9 JMP® Tukey-Kramer HSD

# Future State

## Targeted Multi-skill Analysis

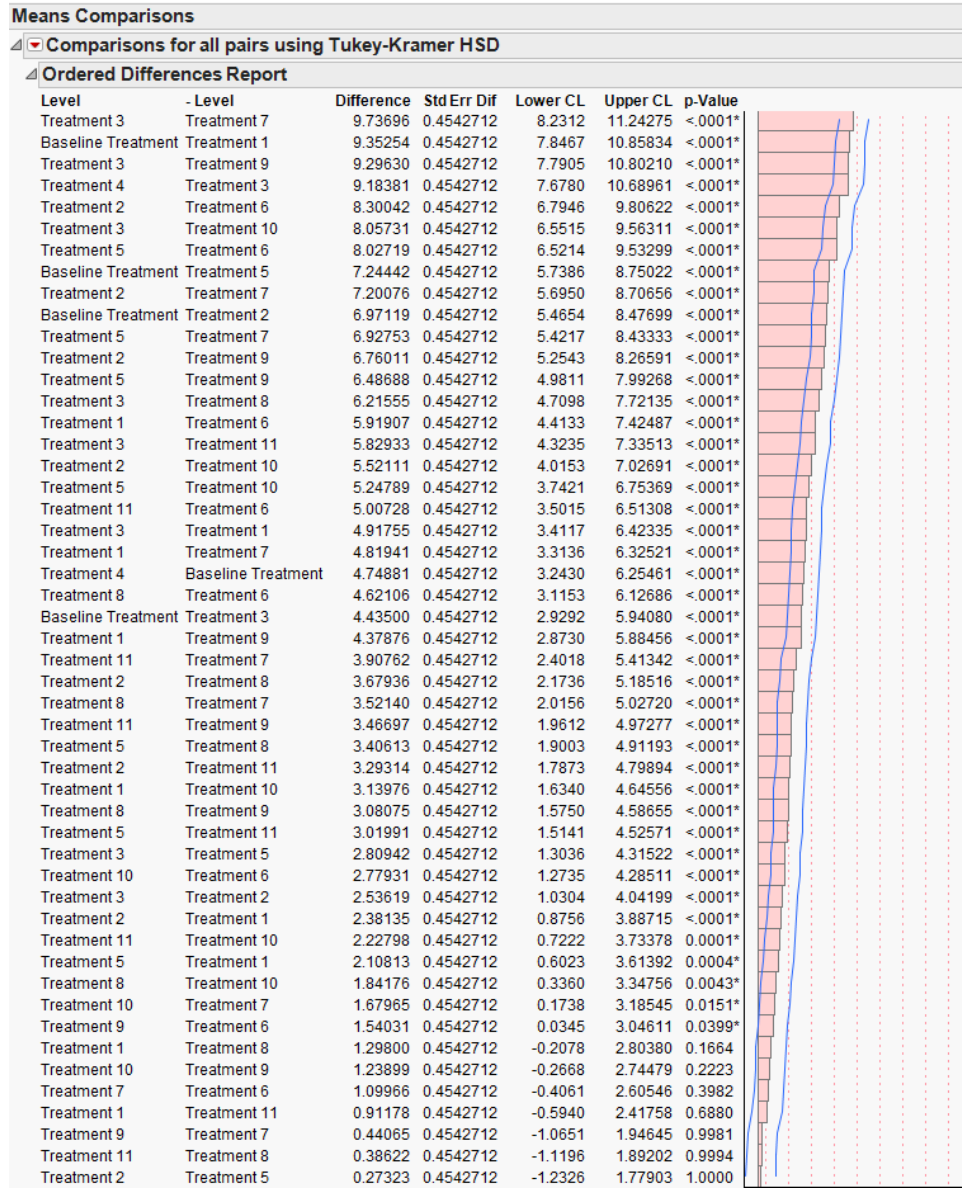


Figure 71: Future State – Targeted Multi-skill JMP® Tukey-Kramer HSD

## Multi-skill Add – 15 Percent Targeted Experiment 6

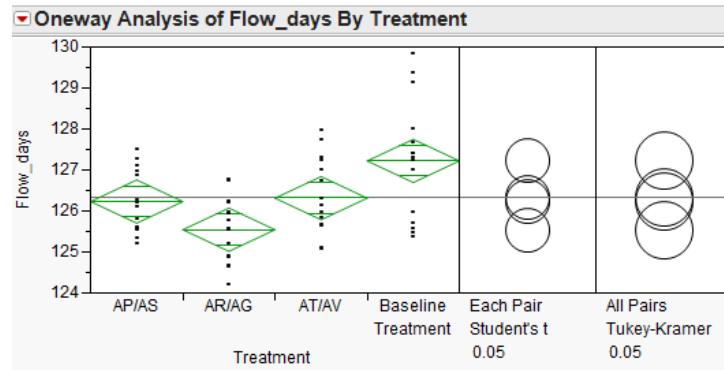


Figure 72: Future State – (E6) Add Experiment F1 JMP® ANOVA

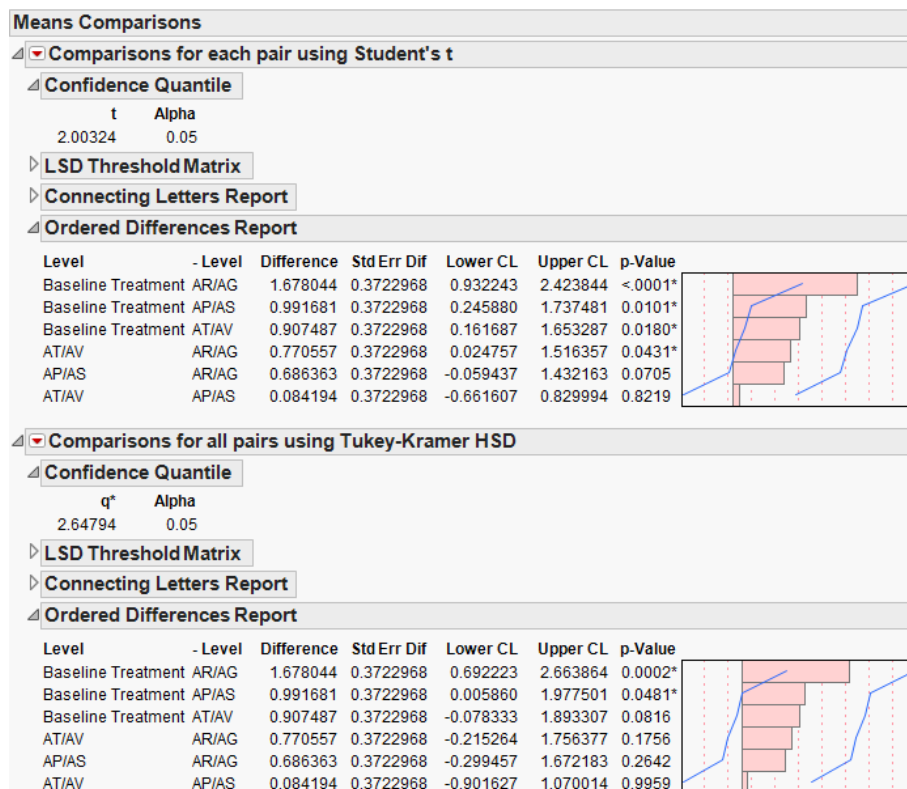


Figure 73: Future State – (E6) Add Experiment F1 JMP® Student's t & Tukey-Kramer HSD

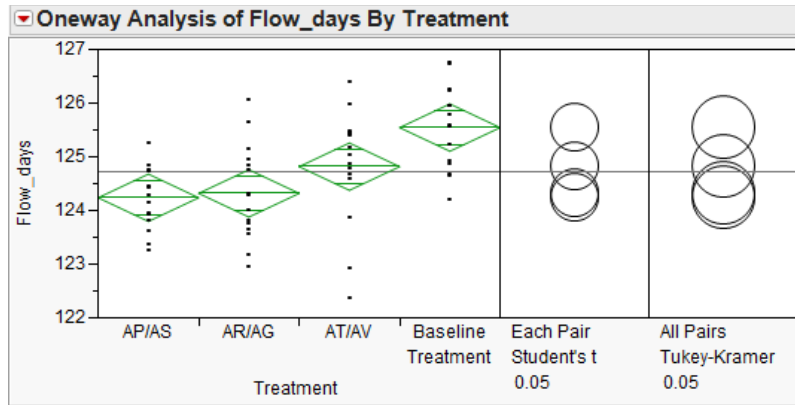


Figure 74: Future State – (E6) Add Experiment F2 JMP® ANOVA

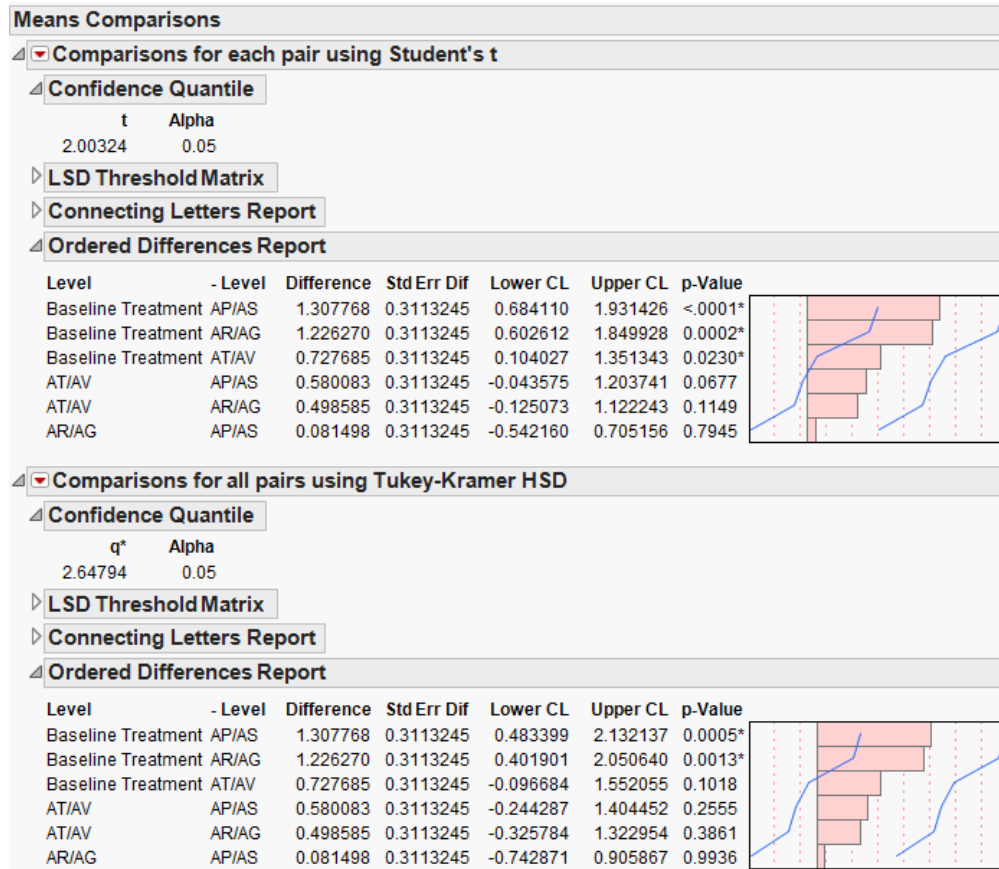


Figure 75: Future State – (E6) Add Experiment F2 JMP® Student's t & Tukey-Kramer HSD

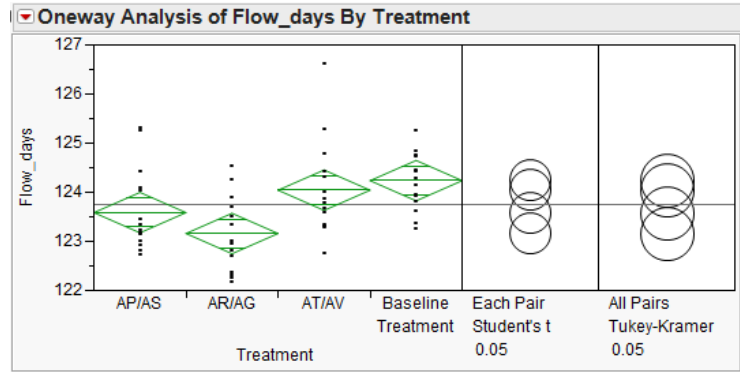


Figure 76: Future State – (E6) Add Experiment F3 JMP® ANOVA

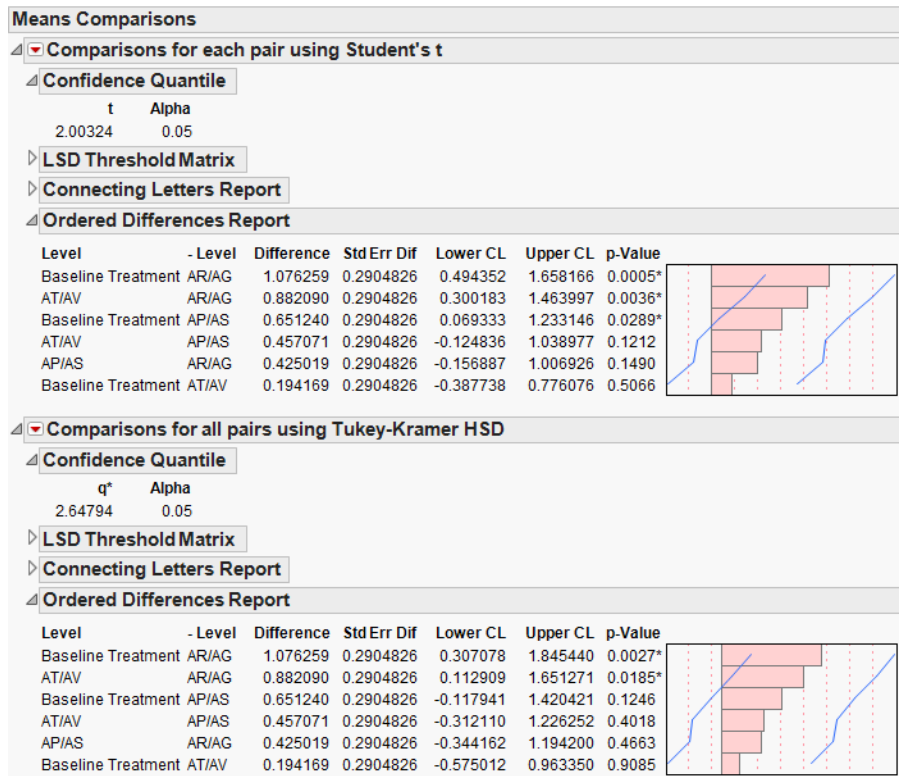


Figure 77: Future State – (E6) Add Experiment F3 JMP® Student's t & Tukey-Kramer HSD

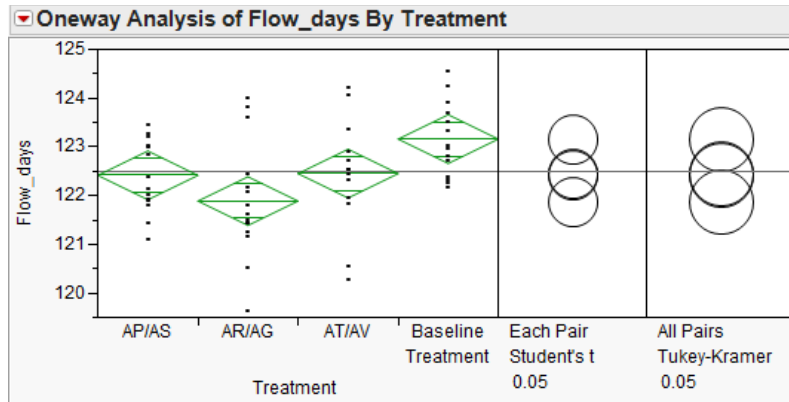


Figure 78: Future State – (E6) Add Experiment F4 JMP® ANOVA

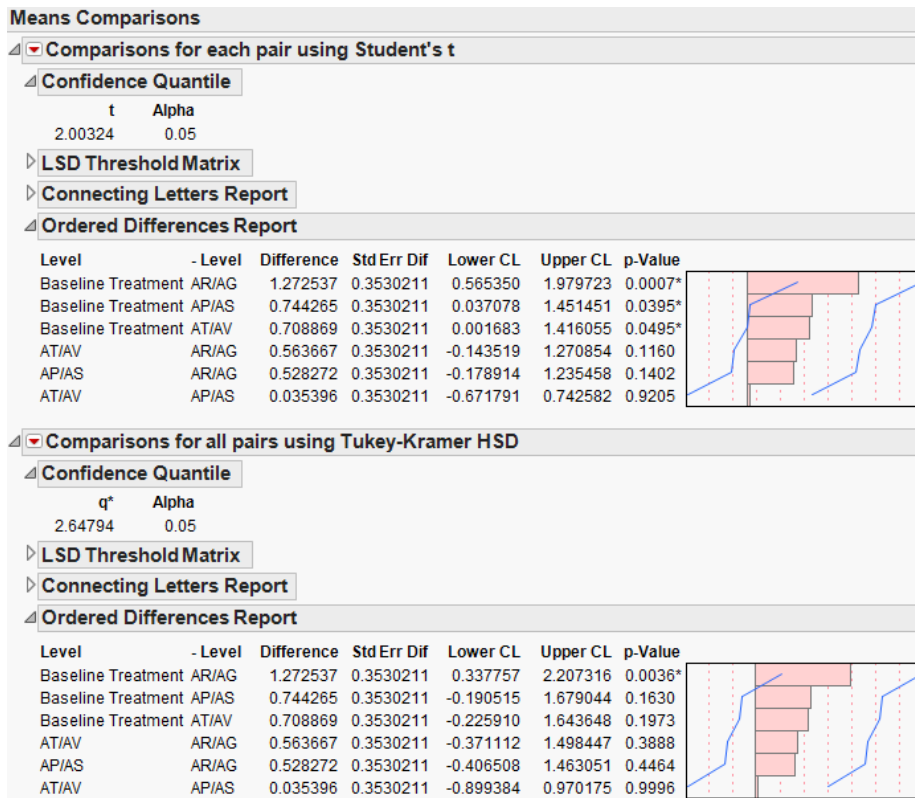


Figure 79: Future State – (E6) Add Experiment F3 JMP® Student's t & Tukey-Kramer HSD

# Multi-skill Add – 15 Percent Targeted Experiment 9 (E9)

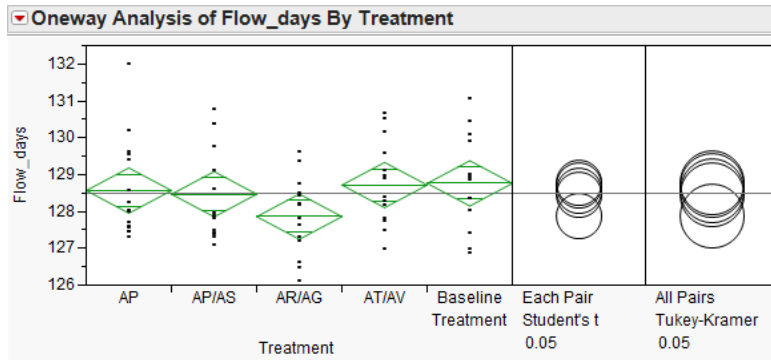


Figure 80: Future State – (E9) Add Experiment G1 JMP® ANOVA

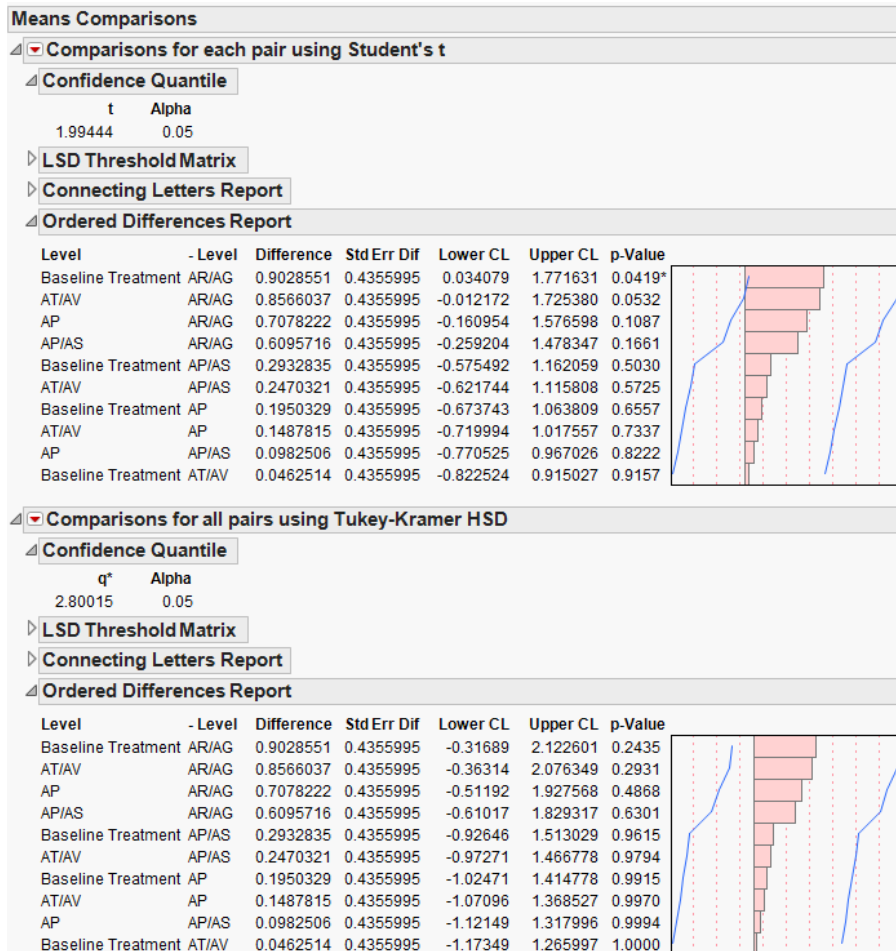


Figure 81: Future State – (E9) Add Experiment G1 JMP® Student's t & Tukey-Kramer HSD

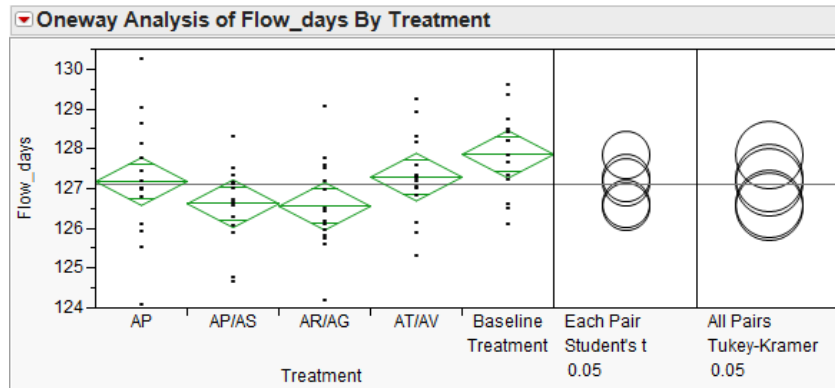


Figure 82: Future State – (E9) Add Experiment G2 JMP® ANOVA

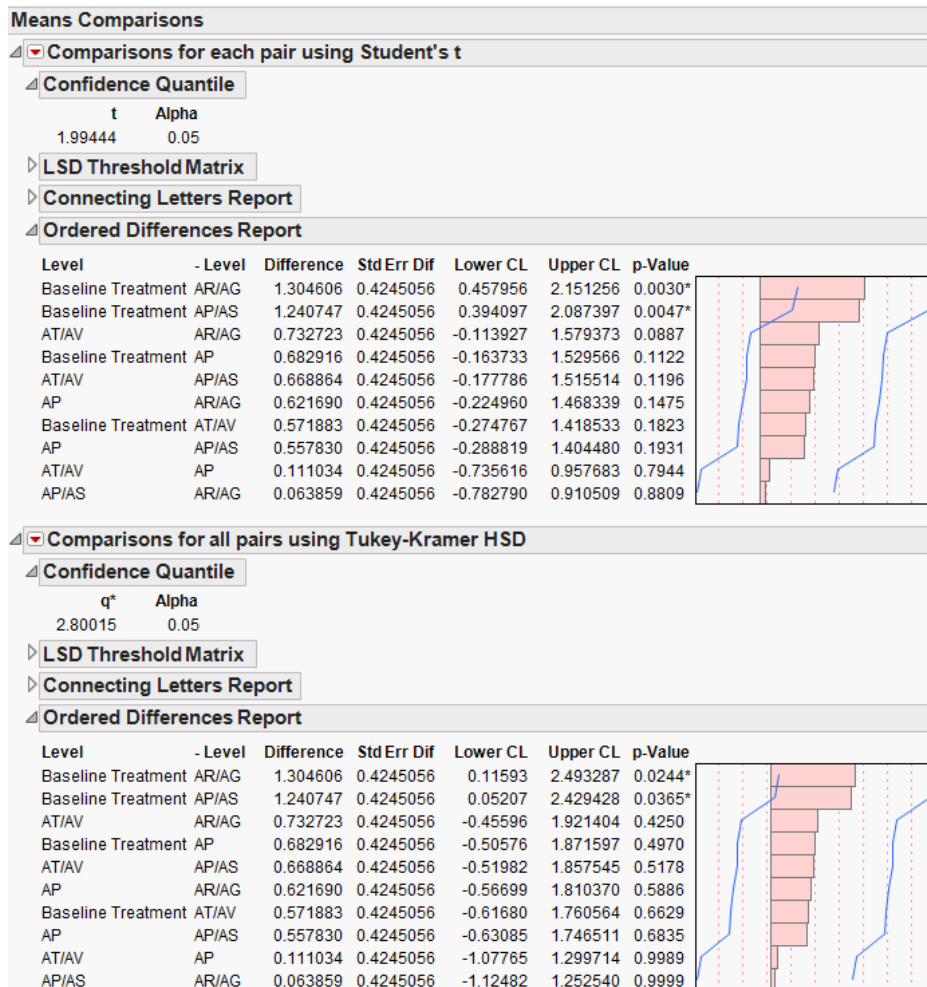


Figure 83: Future State – (E9) Add Experiment G2 JMP® Student's t & Tukey-Kramer HSD

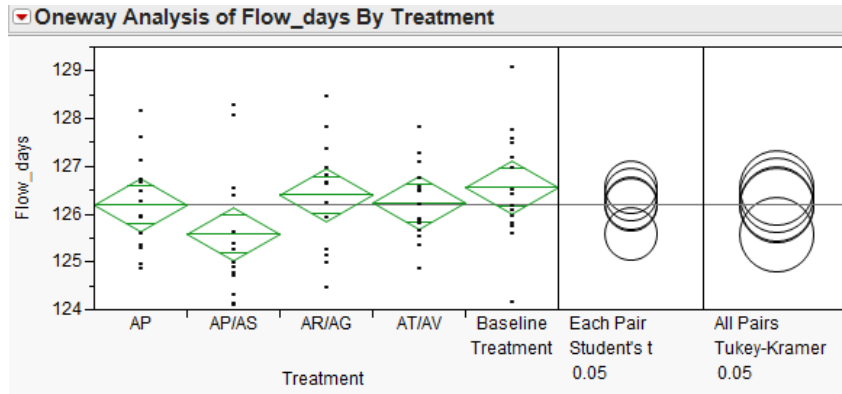


Figure 84: Future State – (E9) Add Experiment G3 JMP® ANOVA

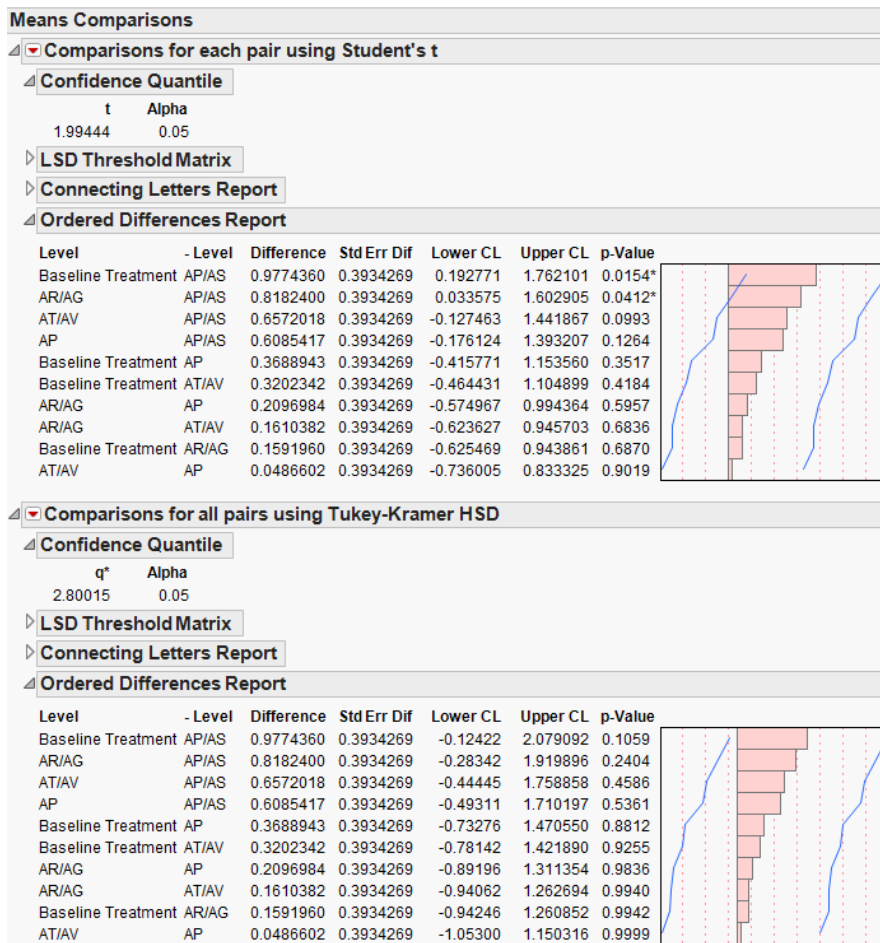


Figure 85: Future State – (E9) Add Experiment G3 JMP® Student's t & Tukey-Kramer HSD

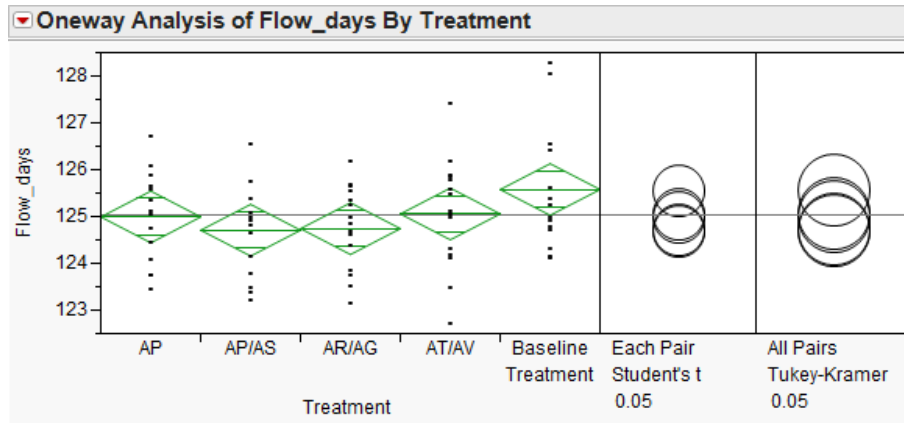


Figure 86: Future State – (E9) Add Experiment G4 JMP® ANOVA

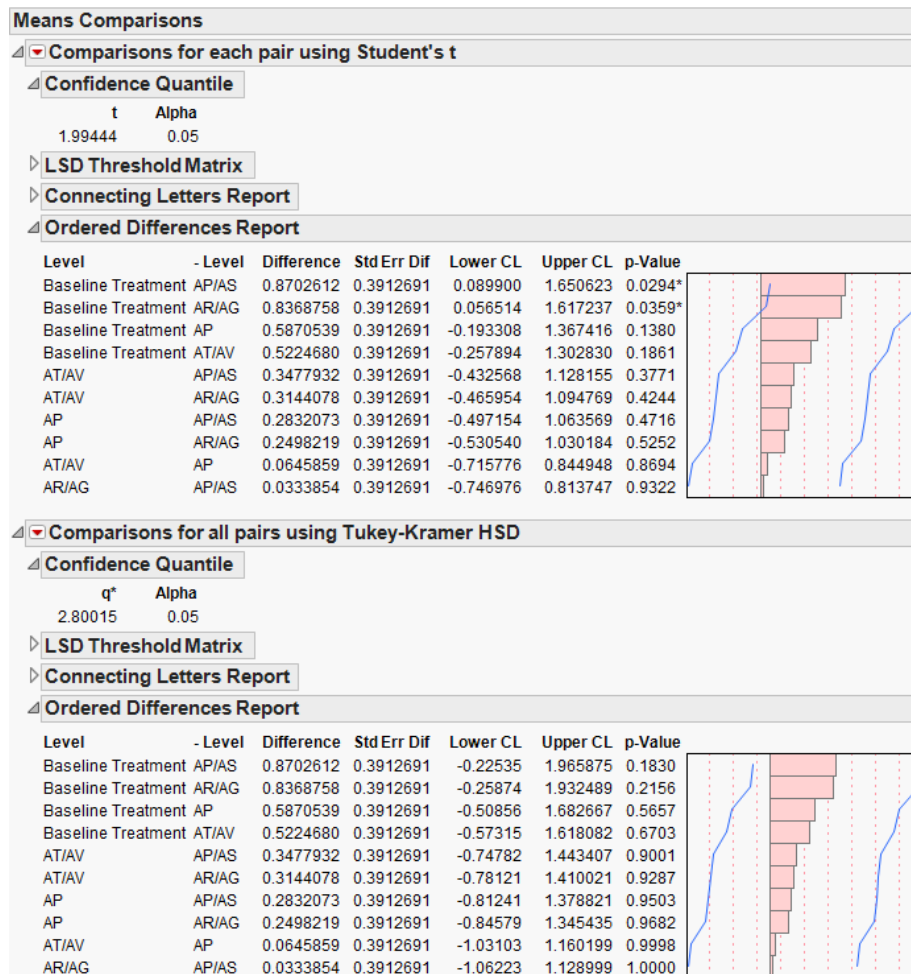


Figure 87: Future State – (E9) Add Experiment G4 JMP® Student's t & Tukey-Kramer HSD

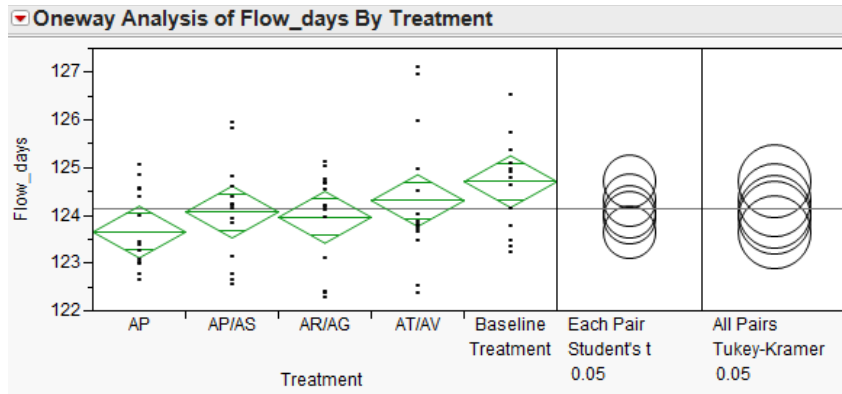


Figure 88: Future State – (E9) Add Experiment G5 JMP® ANOVA

**Means Comparisons**

▾ Comparisons for each pair using Student's t

▾ Confidence Quantile

t	Alpha
1.99444	0.05

▾ LSD Threshold Matrix

▾ Connecting Letters Report

▾ Ordered Differences Report

Level	- Level	Difference	Std Err Dif	Lower CL	Upper CL	p-Value
Baseline Treatment	AP	1.056261	0.3847053	0.288990	1.823531	0.0077*
Baseline Treatment	AR/AG	0.747292	0.3847053	-0.019979	1.514562	0.0561
AT/AV	AP	0.658363	0.3847053	-0.108908	1.425633	0.0914
Baseline Treatment	AP/AS	0.636893	0.3847053	-0.130378	1.404163	0.1023
AP/AS	AP	0.419368	0.3847053	-0.347903	1.186639	0.2794
Baseline Treatment	AT/AV	0.397898	0.3847053	-0.369373	1.165169	0.3046
AT/AV	AR/AG	0.349394	0.3847053	-0.417877	1.116664	0.3669
AR/AG	AP	0.308969	0.3847053	-0.458302	1.076240	0.4246
AT/AV	AP/AS	0.238995	0.3847053	-0.528276	1.006265	0.5365
AP/AS	AR/AG	0.110399	0.3847053	-0.656872	0.877669	0.7750

▾ Comparisons for all pairs using Tukey-Kramer HSD

▾ Confidence Quantile

q*	Alpha
2.80015	0.05

▾ LSD Threshold Matrix

▾ Connecting Letters Report

▾ Ordered Differences Report

Level	- Level	Difference	Std Err Dif	Lower CL	Upper CL	p-Value
Baseline Treatment	AP	1.056261	0.3847053	-0.020973	2.133495	0.0573
Baseline Treatment	AR/AG	0.747292	0.3847053	-0.329942	1.824526	0.3050
AT/AV	AP	0.658363	0.3847053	-0.418871	1.735597	0.4338
Baseline Treatment	AP/AS	0.636893	0.3847053	-0.440341	1.714127	0.4678
AP/AS	AP	0.419368	0.3847053	-0.657866	1.496602	0.8110
Baseline Treatment	AT/AV	0.397898	0.3847053	-0.679336	1.475132	0.8386
AT/AV	AR/AG	0.349394	0.3847053	-0.727840	1.426628	0.8928
AR/AG	AP	0.308969	0.3847053	-0.768265	1.386203	0.9288
AT/AV	AP/AS	0.238995	0.3847053	-0.838239	1.316229	0.9712
AP/AS	AR/AG	0.110399	0.3847053	-0.966835	1.187633	0.9985

Figure 89: Future State – (E9) Add Experiment G5 JMP® Student's t & Tukey-Kramer HSD

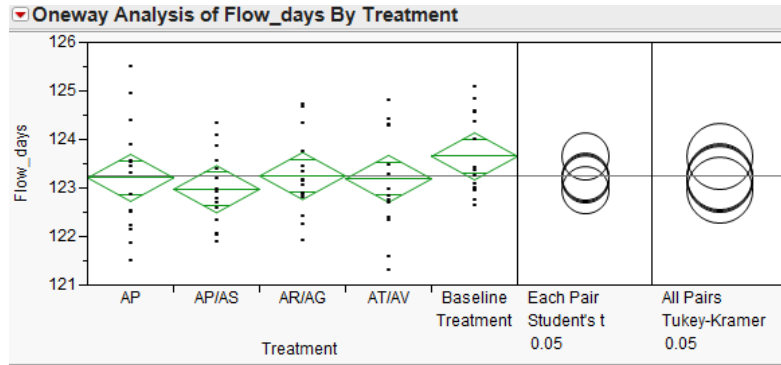


Figure 90: Future State – (E9) Add Experiment G6 JMP® ANOVA

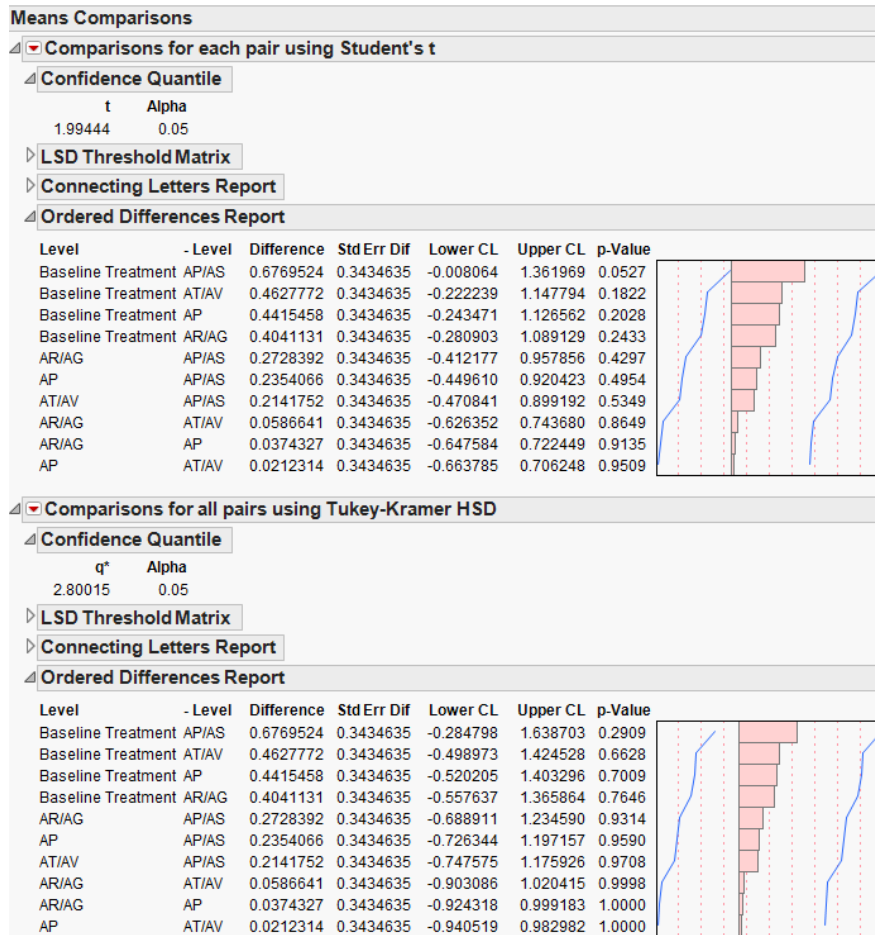


Figure 91: Future State – (E9) Add Experiment G6 JMP® Student's t & Tukey-Kramer HSD

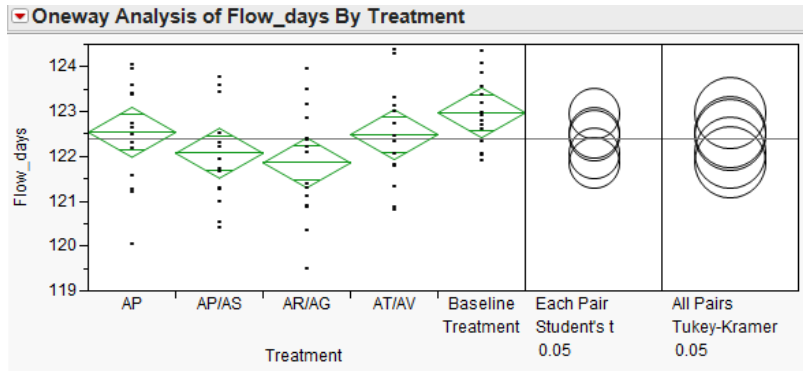


Figure 92: Future State – (E9) Add Experiment G7 JMP® ANOVA

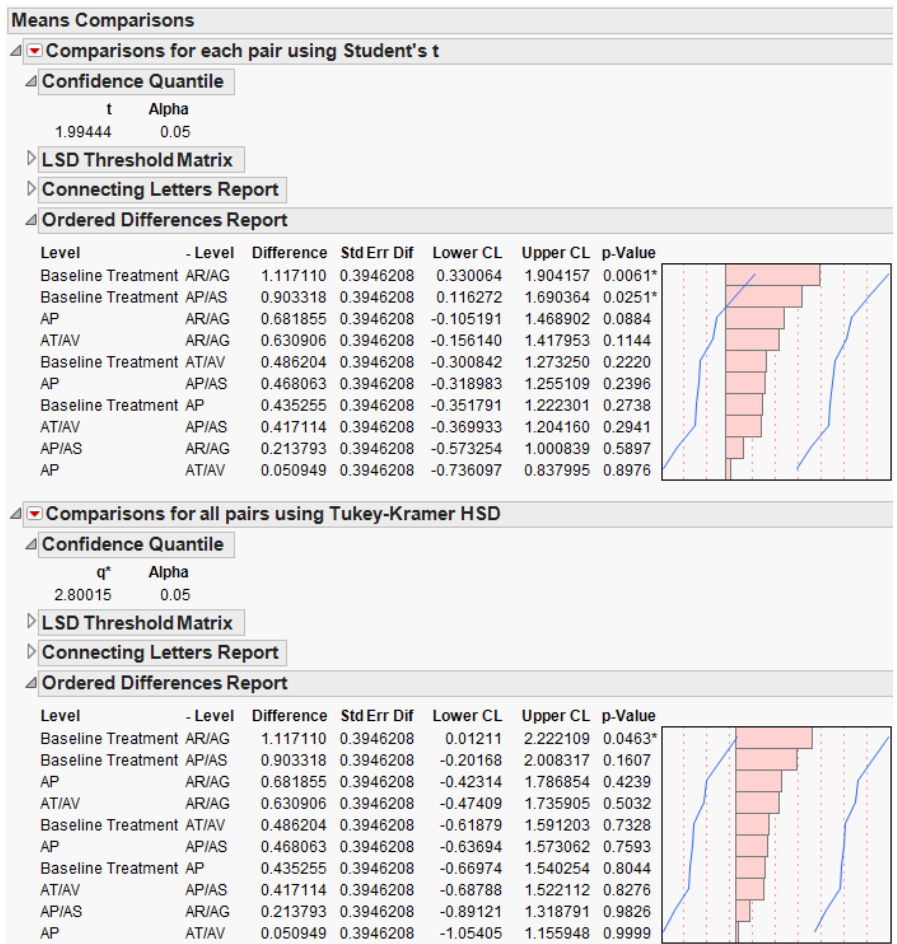


Figure 93: Future State – (E9) Add Experiment G7 JMP® Student's t & Tukey-Kramer HSD

## Bibliography

- Air Force Journal of Logistics. (2003). *Depot Reengineering 2003: Improving Support*. Maxwell AFB: Air Force Journal of Logistics.
- Anupindi, R., Chopra, S., Deshmukh D, S., Van Mieghem A, J., & Zemel, E. (2011). *Managing Business Process Flows 3rd Edition*. Upper Saddle River: Prentice Hall.
- Banks, J., Carson II S, J., Nelson L, B., & Nicol M, D. (2010). *Discrete-Event System Simulation 5th Edition*. Upper Saddle River: Prentice Hall.
- Carson II, J. S. (2005). Introduction to Modeling and Simulation. *2005 Winter Simulation Conference*, (pp. 16-23).
- Carson, J. S. (2002). Model Verification and Validation. *Proceedings of the 2002 Winter Simulation Conference*, (pp. 52-58).
- Cioppa, T. M., & Lucas, T. W. (2007). Efficient Nearly Orthogonal and Space-Filling Latin Hypercubes. *Technometrics* , 45-55.
- de Neufville, R. (1990). *Applied Systems Analysis*. New York: McGraw-Hill Publishing Company.
- Dunn, G., Barone, J. C., & Peterson, L. E. (2003). Depot Maintenance Reengineering, Workforce. *Air Force Journal of Logistics* , 11-12.
- Federal Service Impasse Panel. (1997). *Combined Source Set 1 Federal Service Impasse Panel Decisions*. Wright Patterson AFB: Air Force.
- Federal Service Impasses Panel. (1997, November 12). Case No. 97 FSIP 88. *Combined Source Set 1 - Federal Service Impasses Panel Decisions* .
- Goldratt, E. M., & Cox, J. (1984). *The Goal*. Great Barrington: The North River Press.
- Hammer, M., & Champy, J. (1993). *Reengineering the Corporation a Manifesto for Business Revolution*. New York: Harper Business.
- Kim, S.-H., & Nelson, B. L. (2006). Selecting the Best System. In S. G. Henderson, & B. L. Nelson, *Handbook in OR & MS, Vol 13* (pp. 501-535). Elsevier B.V.
- Law, A. M. (2007). *Simulation Modeling & Analysis 4th Edition*. New York: McGraw-Hill.
- Levien, A. J. (2010). *RESTRUCTURING DEPOT MAINTENANCE OCCUPATIONAL SERIES TO IMPROVE FLEXIBILITY*. Wright-Patterson Air Force Base: Air Force Institute of Technology.

- Little, J. D. (2004). Model and Managers: The Concept of Decision Calculus. *Management Science* , 1841-1853.
- Montgomery, D. C. (2013). *Design and Analysis of Experiments*. Hoboken: John Wiley & Sons, Inc.
- Nelson, B. L., Swann, J., Goldsman, D., & Song, W. (2001). Simple Procedures for Selecting the Best Simulated System When the Number of Alternatives is Large. *Operations Research* , 49 (6): 950-963.
- Office of Personnel Management. (n.d.). Proposed Multi-Trades Demonstration Project; Department of the Air Force. *Proposed Multi-Trades Demonstration Project; Department of the Air Force [DRAFT]* .
- Ogden Air Logistics Center. (2012). *Multi-Trade Demonstration Project*. Acquisition Cost Division.
- Park, P. S. (1991). The examination of worker cross-training in a dual resource constrained job. *European Journal for Operational Research* , 291-299.
- Sadowski, D. A., & Grabau, M. R. (2004). Tips for Successful Practice of Simulation. *Proceedings of the 2004 Winter Simulation Conference*, (pp. 61-66).
- Sanchez, S. M. (2005). Work Smarter, Not Harder: Guidelines For Designing Simulation Experiments. *Proceedings of the 2005 Winter Simulation Conference* (pp. 69-82). Winter Simulation Conference.
- Slay, F. M., Bachman, T. C., Kline, R. C., O'Malley, T. J., Eichorn, F. L., & King, R. M. (1996). *Optimizing Spares Support: The Aircraft Sustainability Model*. McClean: Logistics Management Institute.
- United States Air Force. (2013, May 29). *News*. Retrieved September 11, 2013, from The Official Website of Wright-Patterson Air Force Base: <http://www.wpafb.af.mil/news/story.asp?id=123350437>
- Womack, J. P., & Jones, D. T. (2003). *LEAN THINKING: Banish Waste and Create Wealth In Your Corporation*. New York: Free Press.
- Ysebaert, S. C. (2011). *An Analytical Approach To Low Observable Maintenance Practices Using Simulation and Marginal Analysis (Masters Thesis)*.
- Covey, S. R. (2004). *The 7 habits of highly effective people: Restoring the character ethic*. New York: Free Press.

<b>REPORT DOCUMENTATION PAGE</b>			<i>Form Approved OMB No. 074-0188</i>		
<p>The public reporting burden for this collection of information is estimated to average 1 hour per response, including the time for reviewing instructions, searching existing data sources, gathering and maintaining the data needed, and completing and reviewing the collection of information. Send comments regarding this burden estimate or any other aspect of the collection of information, including suggestions for reducing this burden to Department of Defense, Washington Headquarters Services, Directorate for Information Operations and Reports (0704-0188), 1215 Jefferson Davis Highway, Suite 1204, Arlington, VA 22202-4302. Respondents should be aware that notwithstanding any other provision of law, no person shall be subject to a penalty for failing to comply with a collection of information if it does not display a currently valid OMB control number.</p> <p><b>PLEASE DO NOT RETURN YOUR FORM TO THE ABOVE ADDRESS.</b></p>					
<b>1. REPORT DATE (DD-MM-YYYY)</b> 27-03-2014		<b>2. REPORT TYPE</b> Master's Thesis		<b>3. DATES COVERED (From - To)</b> Oct 2012 - Mar 2014	
<b>4. TITLE AND SUBTITLE</b> <b>SIMULATING F-22 HEAVY MAINTENANCE AND MODIFICATIONS WORKFORCE MULTI-SKILLING</b>			<b>5a. CONTRACT NUMBER</b>		
			<b>5b. GRANT NUMBER</b>		
			<b>5c. PROGRAM ELEMENT NUMBER</b>		
			<b>5d. PROJECT NUMBER</b>		
<b>6. AUTHOR(S)</b> Sheppard, Wesley, A. Jr., Captain, USAF			<b>5e. TASK NUMBER</b>		
			<b>5f. WORK UNIT NUMBER</b>		
			<b>8. PERFORMING ORGANIZATION REPORT NUMBER</b> AFIT-ENS-14-M-28		
<b>7. PERFORMING ORGANIZATION NAMES(S) AND ADDRESS(S)</b> Air Force Institute of Technology Graduate School of Engineering and Management (AFIT/EN) 2950 Hobson Street, Building 642 WPAFB OH 45433-7765			<b>10. SPONSOR/MONITOR'S ACRONYM(S)</b>		
<b>9. SPONSORING/MONITORING AGENCY NAME(S) AND ADDRESS(ES)</b> AFMC/A4D Attn: Mr. Steven McBride 4375 Chidlaw Rd WPAFB OH 45433-5006			<b>11. SPONSOR/MONITOR'S REPORT NUMBER(S)</b>		
			DSN: 787-3271 e-mail: steven.mcbride@us.af.mil		
<b>12. DISTRIBUTION/AVAILABILITY STATEMENT</b> DISTRIBUTION STATEMENT A. APPROVED FOR PUBLIC RELEASE; DISTRIBUTION UNLIMITED.					
<b>13. SUPPLEMENTARY NOTES</b> This material is declared a work of the U.S. Government and is not subject to copyright protection in the United States.					
<b>14. ABSTRACT</b> The Air Force faces significant fiscal challenges in the coming years. The aircraft maintenance depot activities at Ogden ALC, Oklahoma City ALC and Warner-Robins ALC face complex operating environments due to the diversity of aircraft or mission design series (MDS) maintained by each depot and the variability of maintenance requirements for each MDS. Further complicating their operations is the variability of maintenance actions required from one aircraft to another within each MDS and a highly specialized workforce that has inherent inflexibility to compensate for the workload variability. Air Force Materiel Command is reviewing maintenance personnel multi-skilling as a method to efficiently absorb the variability of workload and maintenance requirements between aircraft. This research conducts an objective analysis of the F-22 Heavy Maintenance Modification Program by building a discrete event simulation in ARENA 14® and performing a series of designed experiments. The study analyzes whether using a multi-skilled (flexible) workforce will have an impact on productivity of depot maintenance personnel through simulation of several multi-skilling policies. The research shows that multi-skilling policies can significantly outperform overtime-based production timelines at less cost, even if individual skill proficiencies decline.					
<b>15. SUBJECT TERMS</b> Discrete Event Simulation, Flexible Workforce, Multi-skilling, Multiskill, Multi-trade, Depot Maintenance, Air Logistics Complex					
<b>16. SECURITY CLASSIFICATION OF:</b>			<b>17. LIMITATION OF ABSTRACT</b>	<b>18. NUMBER OF PAGES</b>	<b>19a. NAME OF RESPONSIBLE PERSON</b>
a. REPORT	b. ABSTRACT	c. THIS PAGE			Alan W. Johnson, PhD, ENS
U	U	U	UU	183	<b>19b. TELEPHONE NUMBER (Include area code)</b> (937) 255-6565, ext 4703; e-mail: alan.johnson@afit.edu