



DEPARTMENT OF THE NAVY

OFFICE OF COUNSEL
NAVAL UNDERSEA WARFARE CENTER DIVISION
1176 HOWELL STREET NEWPORT RI 02841-1708

IN REPLY REFER TO

Attorney Docket No. 101603
15 Apr 14

The below identified patent application is available for licensing. Requests for information should be addressed to:

TECHNOLOGY PARTNERSHIP ENTERPRISE OFFICE
NAVAL UNDERSEA WARFARE CENTER
1176 HOWELL ST.
CODE 07TP, BLDG. 102T
NEWPORT, RI 02841

Serial Number 13/783,688
Filing Date 4 March 2013
Inventor Joseph T. Ducas

Address any questions concerning this matter to the Office of Technology Transfer at (401) 832-1511.

DISTRIBUTION STATEMENT
Approved for Public Release
Distribution is unlimited

Report Documentation Page

Form Approved
OMB No. 0704-0188

Public reporting burden for the collection of information is estimated to average 1 hour per response, including the time for reviewing instructions, searching existing data sources, gathering and maintaining the data needed, and completing and reviewing the collection of information. Send comments regarding this burden estimate or any other aspect of this collection of information, including suggestions for reducing this burden, to Washington Headquarters Services, Directorate for Information Operations and Reports, 1215 Jefferson Davis Highway, Suite 1204, Arlington VA 22202-4302. Respondents should be aware that notwithstanding any other provision of law, no person shall be subject to a penalty for failing to comply with a collection of information if it does not display a currently valid OMB control number.

1. REPORT DATE 15 APR 2014		2. REPORT TYPE		3. DATES COVERED 00-00-2014 to 00-00-2014	
4. TITLE AND SUBTITLE Crowfoot Wrench				5a. CONTRACT NUMBER	
				5b. GRANT NUMBER	
				5c. PROGRAM ELEMENT NUMBER	
6. AUTHOR(S)				5d. PROJECT NUMBER	
				5e. TASK NUMBER	
				5f. WORK UNIT NUMBER	
7. PERFORMING ORGANIZATION NAME(S) AND ADDRESS(ES) Technology Partnership Enterprise Office, Naval Undersea Warfare Center, 1176 Howell St., Code 07TP, Bldg. 1-2T, Newport, RI, 02841				8. PERFORMING ORGANIZATION REPORT NUMBER	
9. SPONSORING/MONITORING AGENCY NAME(S) AND ADDRESS(ES)				10. SPONSOR/MONITOR'S ACRONYM(S)	
				11. SPONSOR/MONITOR'S REPORT NUMBER(S)	
12. DISTRIBUTION/AVAILABILITY STATEMENT Approved for public release; distribution unlimited					
13. SUPPLEMENTARY NOTES					
14. ABSTRACT					
15. SUBJECT TERMS					
16. SECURITY CLASSIFICATION OF:			17. LIMITATION OF ABSTRACT	18. NUMBER OF PAGES	19a. NAME OF RESPONSIBLE PERSON
a. REPORT unclassified	b. ABSTRACT unclassified	c. THIS PAGE unclassified			

CROWFOOT WRENCH

STATEMENT OF GOVERNMENT INTEREST

[0001] The invention described herein may be manufactured and used by or for the Government of the United States of America for governmental purposes without the payment of any royalties thereon or therefor.

CROSS REFERENCE TO OTHER PATENT APPLICATIONS

[0002] None.

BACKGROUND OF THE INVENTION

(1) Field of the Invention

[0003] The present invention relates to hand tools for turning threaded connectors, and more particularly to a wrench for engaging connectors that are not easily accessible.

(2) Description of the Prior Art

[0004] Various wrenches have been developed for use on machine bolts, nuts and other connectors that are not easily accessible to the mechanic or another person utilizing the wrench. Such devices are designed to grip the bolt head, nut, or connector using a square or hexagonal shape to match the connector. By virtue of specialized design features, such devices enable the mechanic to reach and turn connectors that are otherwise inaccessible because of either tight quarters or an obscured view.

[0005] One such type of wrench is commonly referred to as a crowfoot wrench. The crowfoot wrench typically consists of a flat open end wrench having a square aperture at its distal end. The square aperture is adapted to be engaged by a square drive ratchet wrench extension post. In many applications, connectors are tightly spaced, such as Radio-Frequency (RF) connectors in periscopes and other RF systems. Often there is not sufficient room to provide for the arcing motion of the ratchet wrench in such tight spaces.

[0006] Previous crowfoot wrenches and other current methods used for tightening RF connectors, such as needle nose pliers; do not grip the RF connector properly. Additionally, the methods do not provide for the user to apply the proper torque to the connector. As is known in the art, RF performance suffers without the proper torque on the connector.

SUMMARY OF THE INVENTION

[0007] Accordingly, it is an object of the present invention to provide a tool for turning a connector that is not easily accessible.

[0008] It is a further object of the present invention to provide a tool that grips the connector so as not to slip from the connector when turning the connector.

[0009] It is a still further object of the present invention to provide a tool for turning a connector with the torque recommended for the proper performance of the connector.

[0010] In accordance with these and other objects made apparent hereinafter, a crowfoot wrench is provided having a wrench head with an open end, shaped and sized to fit the connector. A shaft extends perpendicularly to the wrench head and is located adjacent the open end so as to be in close proximity to the connector. A handle extends orthogonally to the end of the shaft distant from the wrench head.

[0011] The shaft extends a distance such that the handle can rotate without interference from the connector. A torque adapter fitting is attached to the handle or shaft so as to be coaxial with the connector. The handle can be turned to hand tighten the connector. A torque wrench can be connected to the torque fitting and operated such that the connector is tightened to the proper torque.

[0012] In one embodiment, a crowfoot wrench for turning a connector includes a wrench head with jaw surfaces that are sized and shaped to fit the connector. A shaft extends perpendicularly from the wrench head and parallel to a longitudinal axis of the connector when the wrench head engages the connector. A torque wrench fitting is attached to an end of the shaft distant from the wrench head. The torque wrench fitting is coaxial with the longitudinal axis of the connector when the wrench head engages the connector.

[0013] The crowfoot wrench can also include a handle attached orthogonally to the end of the shaft. The shaft can be positioned adjacent one of the jaw surfaces, such that the shaft is in close proximity to the connector when the wrench head engages the

connector. The shaft is of such length that the handle is clear of obstructions in the vicinity of the connector. Additionally, the torque wrench fitting is positioned at a distance from the wrench head such that the fitting is also clear of obstructions in the vicinity of the connector.

[0014] In one embodiment, a tool for turning a connector about a longitudinal axis of the tool includes a wrench head configured to engage the connector orthogonally to the longitudinal axis of the connector. A shaft extends from the wrench head and is positioned on the wrench head to be adjacent to the connector and parallel to the longitudinal axis of the connector when the wrench head engages the connector.

[0015] A torque wrench fitting is attached at an end of the shaft distant from the wrench head. The torque wrench fitting is positioned on the shaft such that a longitudinal axis of the torque wrench fitting is coaxial with the longitudinal axis of the connector when the wrench head engages the connector.

[0016] The tool can also include a handle affixed orthogonally to the shaft at a distance from the wrench head such that the handle is clear of obstructions in the vicinity of the connector when the wrench head engages the connector. The torque wrench fitting is also attached to the shaft at a distance from the wrench head such that the torque wrench fitting is also clear of obstructions in the vicinity of the connector when the wrench head engages the connector.

[0017] Other objects, features and advantages of the present invention including various novel details of construction and

combinations of parts, will now be more particularly described with reference to the accompanying drawings and pointed out in the claims. It will be understood that the particular assembly embodying the invention is shown by way of illustration only and not as a limitation of the invention. The principles and features of this invention may be employed in various and numerous embodiments without departing from the scope of the invention.

BRIEF DESCRIPTION OF THE DRAWINGS

[0018] Reference is made to the accompanying drawings in which is shown an illustrative embodiment of the invention, from which its novel features and advantages will be apparent, wherein corresponding reference characters indicate corresponding parts throughout the several views of the drawings and wherein:

[0019] **FIG. 1** is an isometric view of a crowfoot wrench of the present invention;

[0020] **FIG. 2** is a side view of the crowfoot wrench of **FIG. 1**;
and

[0021] **FIG. 3** is a top view of the crowfoot wrench of **FIG. 1**.

DETAILED DESCRIPTION OF THE INVENTION

[0022] Referring now to the drawings, **FIGS. 1, 2 and 3** respectively illustrate schematic isometric, side and top views of a crowfoot wrench **10** of the present invention. As will be apparent in the following description, certain features of the crowfoot wrench **10** and its use are better described and illustrated with reference to a particular view.

[0023] Referring to **FIG. 1**, wrench head **12** is equipped with fixed jaw surfaces **12a** that are shaped and sized to fit connector **2** (shown dashed in **FIG. 1**). A shaft **14** extends a distance **D** (shown in **FIG. 2**) perpendicularly to the wrench head **12** and parallel to axis **X-X** of the connector **2**. A wrench end **14a** of the shaft **14** is positioned adjacent the jaw surfaces **12a** so as to be in close proximity to the connector **2** when the wrench head **12** engages the connector **2**.

[0024] Handle **16** extends orthogonally to either side of end **14b** (shown in **FIG. 2**) of the shaft **14** distant from the wrench head **12**. Distance **D** is such that the handle **16** can rotate about axis **X-X** without interference from the connector **2**, or from adjacent connectors, or other nearby objects (not shown in the views).

[0025] Torque adaptor fitting **18** is attached to one or both of the shaft **14** and the handle **16** so as to be coaxial with the connector **2** when the wrench head **12** engages the connector. The handle **16** can be turned by hand to tighten the connector **2**. As is known in the art, a torque wrench (not shown in the views) can be connected to the torque fitting **18** and the torque wrench can be operated such that the connector **2** is tightened to the proper torque.

[0026] What has thus been described is a crowfoot wrench (**10**) for turning a connector (**2**) that is not easily accessible. Fixed jaw surfaces **12a** on a wrench head **12** of the crowfoot wrench **10** are sized and shaped to grip the connector and minimize slippage from the connector when turning the connector. Additionally, the crowfoot wrench **10** includes a torque fitting **18**, whereby a torque

wrench can be connected to the crowfoot wrench so as to turn the connector **2** with the torque recommended for the proper performance of the connector.

[0027] The foregoing description of the preferred embodiments of the invention has been presented for purposes of illustration and description only. It is not intended to be exhaustive or to limit the invention to the precise form disclosed; and obviously many modifications and variations are possible in light of the above teaching.

[0028] For example, though the shaft **14** is illustrated as having a round cross-section, the shaft can be fabricated with any cross-section that can be securely affixed to the wrench head **12** and that provides sufficient strength to limit twisting of the shaft **14** when the connector is fully torqued. Similarly, the handle **16** also can be fabricated with one of numerous cross-sections that provide sufficient stiffness to hand tighten the connector **2**. The round cross-section illustrated in **FIGS. 1** and **2** provides a comfortable grip for the user of the crowfoot wrench **10**.

[0029] Furthermore, both the jaw surfaces **12a** and the torque fitting **18** are illustrated as being hexagonal. As is known in the art, connectors and torque wrenches can be one of numerous shapes, including, but not limited to squares, octagons and stars. As described previously, the jaw surfaces **12a** and also the torque fitting **18** are sized and shaped to fit the connector and torque wrench, respectively. Additionally, the attachment of the handle **16** and the torque fitting **18** to the shaft **14** can have any of

numerous configurations provided that the handle can be adequately grasped to hand tighten the connector and that the connector and the torque fitting are coaxial.

[0030] It will be understood that many additional changes in the details, materials, steps and arrangement of parts, which have been herein described and illustrated in order to explain the nature of the invention, may be made by those skilled in the art within the principle and scope of the invention as expressed in the appended claims.

CROWFOOT WRENCH

ABSTRACT OF THE DISCLOSURE

A crowfoot wrench is provided having a wrench head with an open end, shaped and sized to fit a connector. A shaft extends perpendicularly to the wrench head and parallel to the longitudinal axis of the connector. The shaft is located adjacent the open end so as to be in close proximity to the connector. A handle extends orthogonally to the end of the shaft distant from the wrench head. The shaft extends a distance such that the handle can rotate without interference from the connector. A torque adaptor fitting is attached to the handle or shaft so as to be coaxial with the connector.

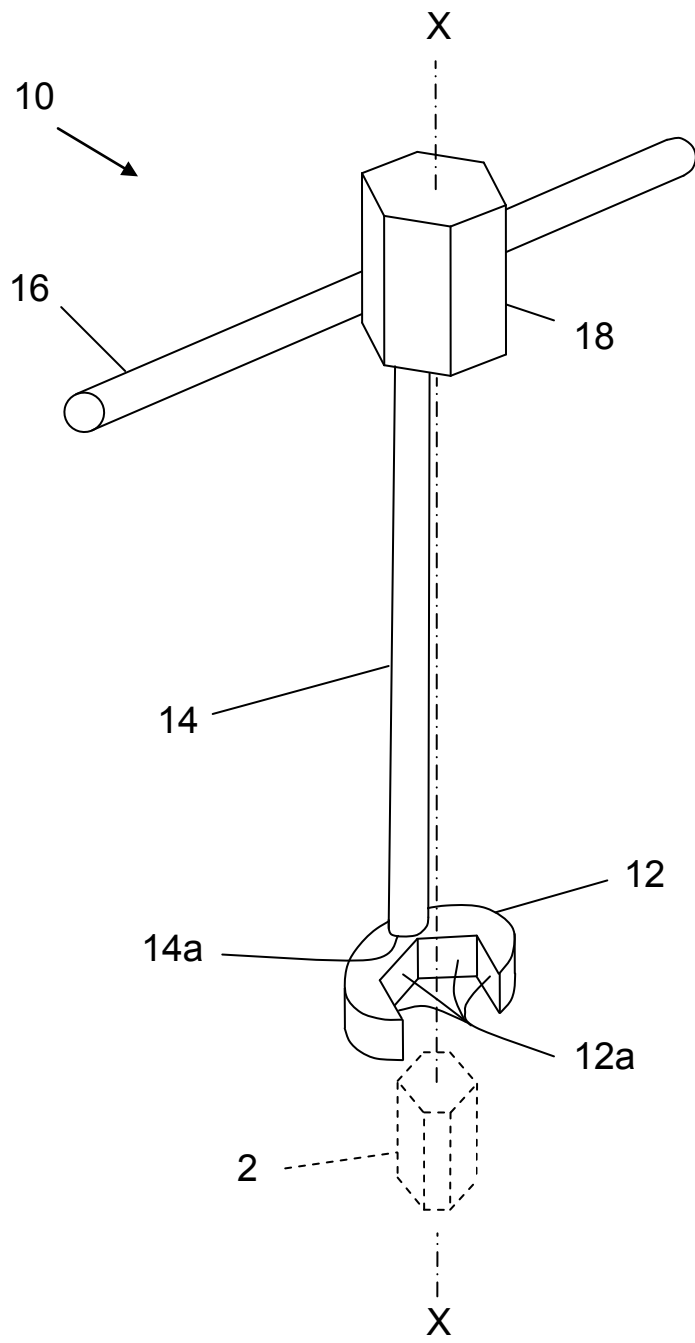

FIG. 1

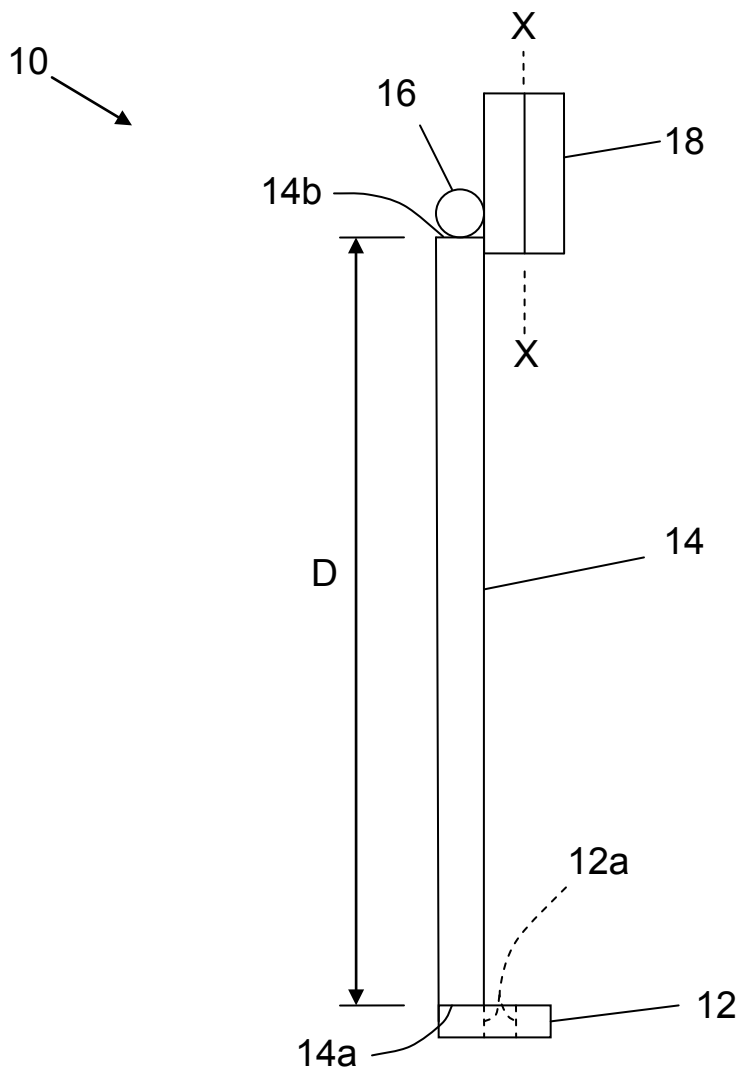

FIG. 2

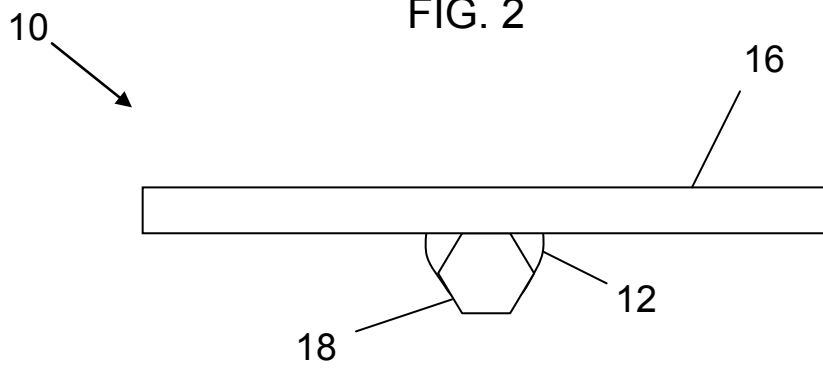

FIG. 3