



DEPARTMENT OF THE NAVY

OFFICE OF COUNSEL
NAVAL UNDERSEA WARFARE CENTER DIVISION
1176 HOWELL STREET NEWPORT RI 02841-1708

IN REPLY REFER TO

Attorney Docket No. 101699
15 Apr 14

The below identified patent application is available for licensing. Requests for information should be addressed to:

TECHNOLOGY PARTNERSHIP ENTERPRISE OFFICE
NAVAL UNDERSEA WARFARE CENTER
1176 HOWELL ST.
CODE 07TP, BLDG. 102T
NEWPORT, RI 02841

Serial Number 13/628,736
Filing Date 27 September 2012
Inventor Heather L. Chamblee

Address any questions concerning this matter to the Office of Technology Transfer at (401) 832-1511.

DISTRIBUTION STATEMENT
Approved for Public Release
Distribution is unlimited

Report Documentation Page

Form Approved
OMB No. 0704-0188

Public reporting burden for the collection of information is estimated to average 1 hour per response, including the time for reviewing instructions, searching existing data sources, gathering and maintaining the data needed, and completing and reviewing the collection of information. Send comments regarding this burden estimate or any other aspect of this collection of information, including suggestions for reducing this burden, to Washington Headquarters Services, Directorate for Information Operations and Reports, 1215 Jefferson Davis Highway, Suite 1204, Arlington VA 22202-4302. Respondents should be aware that notwithstanding any other provision of law, no person shall be subject to a penalty for failing to comply with a collection of information if it does not display a currently valid OMB control number.

1. REPORT DATE 15 APR 2014	2. REPORT TYPE	3. DATES COVERED 00-00-2014 to 00-00-2014			
4. TITLE AND SUBTITLE Carbon Nanotube Polymer Composite Hose Wall		5a. CONTRACT NUMBER			
		5b. GRANT NUMBER			
		5c. PROGRAM ELEMENT NUMBER			
6. AUTHOR(S)		5d. PROJECT NUMBER			
		5e. TASK NUMBER			
		5f. WORK UNIT NUMBER			
7. PERFORMING ORGANIZATION NAME(S) AND ADDRESS(ES) Technology Partnership Enterprise Office, Naval Undersea Warfare Center, 1176 Howell St., Code 07TP, Bldg. 102T, Newport, RI, 02841		8. PERFORMING ORGANIZATION REPORT NUMBER			
9. SPONSORING/MONITORING AGENCY NAME(S) AND ADDRESS(ES)		10. SPONSOR/MONITOR'S ACRONYM(S)			
		11. SPONSOR/MONITOR'S REPORT NUMBER(S)			
12. DISTRIBUTION/AVAILABILITY STATEMENT Approved for public release; distribution unlimited					
13. SUPPLEMENTARY NOTES					
14. ABSTRACT					
15. SUBJECT TERMS					
16. SECURITY CLASSIFICATION OF:			17. LIMITATION OF ABSTRACT	18. NUMBER OF PAGES	19a. NAME OF RESPONSIBLE PERSON
a. REPORT unclassified	b. ABSTRACT unclassified	c. THIS PAGE unclassified	Same as Report (SAR)	15	

CARBON NANOTUBE POLYMER COMPOSITE HOSE WALL

STATEMENT OF GOVERNMENT INTEREST

[0001] The invention described herein may be manufactured and used by or for the Government of the United States of America for governmental purposes without the payment of any royalties thereon or therefore.

CROSS REFERENCE TO OTHER PATENT APPLICATIONS

[0002] None.

BACKGROUND OF THE INVENTION

(1) Field of the Invention

[0003] The present invention generally relates to a towed acoustic sensor array. More particularly, the invention is an improved hose wall of an acoustic towed array in which the hose wall provides strengthening and increased reliability.

(2) Description of the Prior Art

[0004] Naval vessels and geophysical exploration vessels routinely deploy acoustic arrays for detection and analysis of undersea structures and objects. A vessel can tow an array of sound receiving hydrophones arranged in a passive array hose. The passive array hose, in conjunction with sound receiving and signal processing electronics, can detect sounds in the water.

[0005] In other arrangements, the vessel can tow a passive array of sound receiving hydrophones and can also tow an acoustic projector in which the hydrophones and the projector form a bi-static active sonar system. With this arrangement, the towed acoustic projector emits sound pulses. Each sound pulse travels through the water to strike objects or targets, which in turn produce echoes. The echoes are received by the array of hydrophones. The direction of the echoes indicates the location of an underwater object. In conventional bi-static active sonar systems, the acoustic projector is often deployed and towed separately from the array.

[0006] United States Patent Number 6,683,819 discloses a sonar array system including a receiving array of hydrophones and a transmit array of acoustic projectors disposed on a common axis of a cable. The cable is extended and retrieved by a winch. The transmit array has one or more acoustic projectors capable of generating sound and the receive array has one or more hydrophones capable of receiving sound. The acoustic projectors are disposed on a transmit array axis, and the one or more hydrophones are disposed on a receive array axis. The receive array axis and the transmit array axis have a common axis; therefore, forming contiguous line arrays (one array for receiving and one array for transmitting).

[0007] The towed array is typically attached to a tow cable that is reeled off a ship so that the sonar array stretches for a distance of a mile or more. Due to the forces imposed (flow-induced vibration and drag) on the towed array because of the reeling; improvements in strengthening are desirable for increasing reliability and life span of the acoustic array.

[0008] In addition to concerns about mechanical wear and strength, improvements in removing heat from various components of a sonar array system are helpful for extending the longevity of electronic components and in preventing electrical breakdown between various components of the array system.

SUMMARY OF THE INVENTION

[0009] Accordingly, it is an object of the present invention to improve the strength, durability and lifespan of an acoustic towed array.

[0010] Another object of the present invention is to provide improved heat transfer from the acoustic towed array.

[0011] To attain the objects described, an acoustic towed array is provided and includes acoustic sensors and nonconductive fill fluid circumferentially surrounding the acoustic sensors, internal strength members, and a hose wall of polyurethane composite including single wall carbon nanotubes embedded therein. The hose wall circumferentially surrounds the nonconductive fill fluid.

When an electrical field (generated on the towing vessel and external to the array) is applied to the hose during handling (reeling or unreeling); the carbon nanotubes impregnated in the hose wall become aligned in a parallel orientation, thereby stiffening and strengthening the hose of the towed array.

[0012] The heat conductive carbon nanotubes also promote passive heat transfer through the hose wall; thereby, reducing failures of the internal electrical components due to overheating. The carbon nanotubes need not be aligned for improved thermal heat conduction. As such, the mere presence of the carbon nanotubes within the polyurethane improves heat transfer.

BRIEF DESCRIPTION OF THE DRAWINGS

[0013] The above and other objects, features and advantages of the present invention will become apparent in view of the following figures taken in conjunction with the specification and claims.

[0014] **FIG. 1** is a diagram of a marine vessel towing an acoustic towed array in accordance with the invention;

[0015] **FIG. 2** is a prior art view of an acoustic array hose;

[0016] **FIG. 3** is a cross-sectional view of a hose of the towed array in accordance with the invention;

[0017] **FIG. 4A** is a diagram of a section of the hose in accordance with the principles of the invention; and

[0018] **FIG. 4B** is a diagram of the section of the hose of **FIG. 4A** with an electrical field applied thereto.

DETAILED DESCRIPTION OF THE INVENTION

[0019] Referring now to the drawings, and more particularly to **FIG. 1**, a hose of an acoustic towed array **14** is attached to a tow cable **12** behind a marine vessel **100** in which the vessel could be either a surface or a subsurface vessel traveling on or below a water surface **200**. The hose of an acoustic towed array **14** acts as a sonar antenna and may extend for over a mile. The towed array **14** and tow cable **12** can also be towed by low flying aircraft, such as a helicopter or other aircraft.

[0020] The towed array **14** and the tow cable **12** are connected at an end and stored on a reel on the rear of the vessel **100**, then unreeled (as shown) so that the towed array is below the water surface **200**. As the vessel **100** moves in the direction indicated by arrow "A"; the towed array **14** is subjected to drag due to skin friction along a length L_1 of the array; thereby, creating a friction force in the direction shown by arrow "B". In addition to the drag due applied to the towed array **14**; stresses are applied to the array by a winch handling system on the vessel **100** which unreels and reels in the hose of the towed array and the tow cable **12**.

[0021] **FIG. 2** is a prior art diagram of a partial array hose section **500** in which the hose section has a hose wall **510**. An interior **512** of the hose section **500** is typically filled with neutrally-buoyant nonconductive oil. A communication line **514** and a plurality of strength members **516** extend through the fluid-filled interior **512**. The communication line **514** can be either an electrical line or a fiber optic line. Hydrophones **516** are joined to the communication line **514** and positioned at intervals within the interior **512**.

[0022] The hose of the towed array **14** is constructed in accordance with **FIG. 3**. The hose of the towed array **14** includes a composite hose wall **30**.

[0023] Strengthening members **22** are embedded within the polyurethane composite extending along the length L_1 (see **FIG. 1**) of the array hose **14**. The strengthening members **22** are constructed from nylon polyester or from a synthetic fiber of high tensile strength. An electrical or fiber optic communication line **26** also extends along the length of the hose of the towed array **14** and hydrophones (not shown) are joined to and positioned along the communications line. Neutrally buoyant oil **24** fills the space between the communication line **26** and the composite hose wall **30**.

[0024] When the towed array **14** and the tow cable **12** are deployed and extended in the water as shown in **FIG. 1**; then single wall carbon nanotubes **50** are embedded and randomly arranged within

the polyurethane - as shown in **FIG. 4A**. The single wall carbon nanotubes **50** typically have a diameter of approximately one nanometer with a tube length that can be millions of times longer.

[0025] During reeling or unreeling of the towed array **14** and the attached tow cable **12** from the marine vessel **100**; an electrical current is activated from the vessel along the hose of the towed array, which in turn creates an electric field extending radially throughout the composite hose wall **30**. This radially-applied field causes the single wall carbon nanotubes **50** embedded within the composite hose wall **30** to align in a same direction parallel to one another along their longitudinal axes as shown in **FIG. 4B**.

[0026] The electrical current can be applied along the hose of the towed array **14** through the communications line **26**, by other separate electrical wires and components in the hose, or generated by a device in the proximity of the handling system in which the device is independent of the array components.

[0027] By creating an electrical field across the composite hose wall **30** (embedded with the nanotubes **50**); the hose wall and the overall hose of the towed array **14** are stiffened and strengthened during the reeling and unreeling of the cable **12** and the hose of the towed array to and from the vessel **100**; thereby, increasing strength, reliability and lifespan. When the cable **12** and the hose of the towed array **14** are fully extended into the

water for acoustical operations; the acoustical performance of the towed array is unaffected because there is no electrical current being applied to the communication line **26** and there is no electrical field generated across the composite hose wall **30**.

[0028] Since carbon nanotubes are substantive thermal conductors; their presence within the composite hose wall **30** promotes passive heat transfer through the hose wall; thereby, reducing failures due to the overheating of internal components.

[0029] It will be understood that many additional changes in the details, materials, steps and arrangement of parts, which have been herein described and illustrated in order to explain the nature of the invention, may be made by those skilled in the art within the principle and scope of the invention as expressed in the appended claims.

[0030] The foregoing description of the preferred embodiments of the invention has been presented for purposes of illustration and description only. It is not intended to be exhaustive nor to limit the invention to the precise form disclosed; and obviously many modifications and variations are possible in light of the above teaching. Such modifications and variations that may be apparent to a person skilled in the art are intended to be included within the scope of this invention as defined by the accompanying claims.

CARBON NANOTUBE POLYMER COMPOSITE HOSE WALL

ABSTRACT OF THE DISCLOSURE

An acoustic array hose is provided for towing behind a marine vessel. The acoustic array includes acoustic sensors, a hydraulic fill-fluid circumferentially surrounding the acoustic sensors, and an array hose wall of polyurethane with single wall carbon nanotubes embedded therein. The hose wall circumferentially surrounds the hydraulic fill fluid along a length of the array hose. When an electrical current is applied to the towed array, the nanotubes align with the hose wall with the effect of strengthening the hose wall of the towed array.

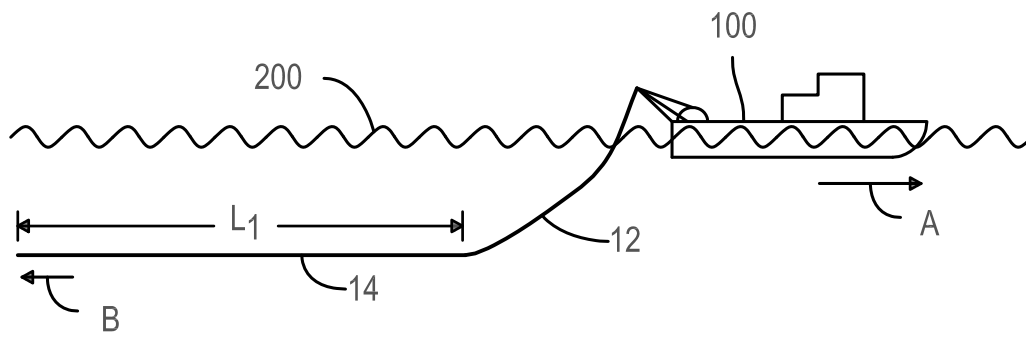

FIG. 1

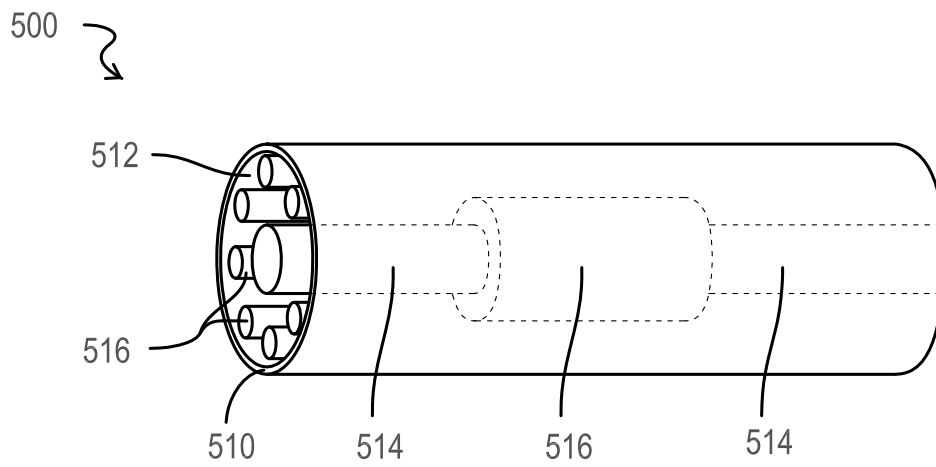

FIG. 2
(PRIOR ART)

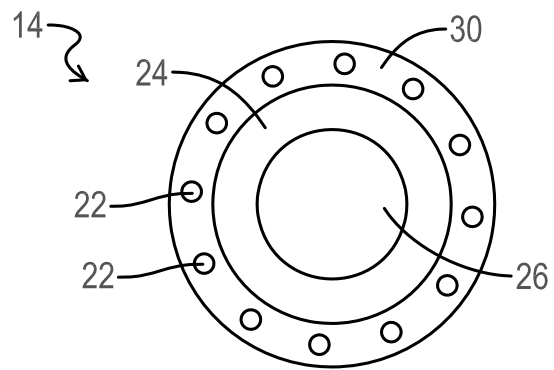

FIG. 3

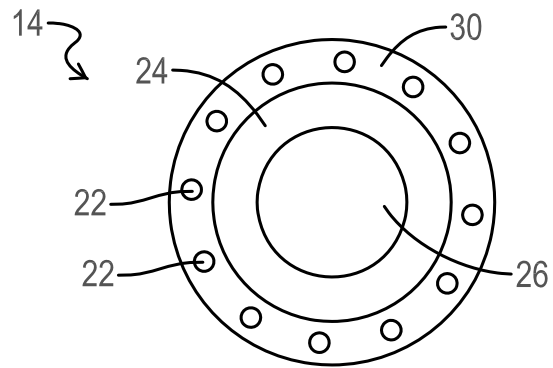

FIG. 3

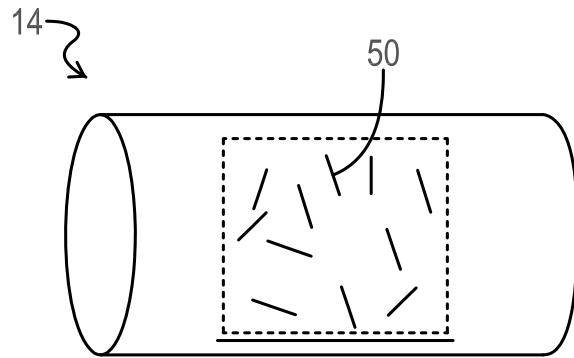

FIG. 4A

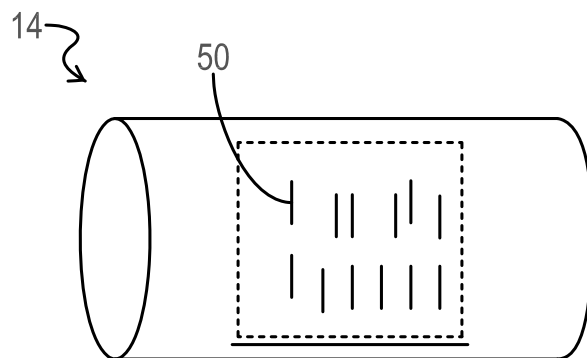

FIG. 4B