

# **Probability of Failure of Damaged Ship Structures – Phase 3**

U. Akpan, B. Yuen, T. S. Koko, F. Lin, J. Wallace  
Martec Limited

Prepared By:  
Martec Limited  
Suite 400, 1888 Brunswick St, Halifax, Nova Scotia, B3J 3J8  
Martec Technical Report TR-13-15  
Contract Project Manager: T.S. Koko, 902-425-5101  
CSA: Malcolm J. Smith, Group Leader/ NPSS, 902-426-3100 ext 383

The scientific or technical validity of this Contract Report is entirely the responsibility of the Contractor and the contents do not entirely have the approval or endorsement of the Department of National Defence of Canada.

DRDC-RDDC-2014-C45  
April 2014

# Report Documentation Page

Form Approved  
OMB No. 0704-0188

Public reporting burden for the collection of information is estimated to average 1 hour per response, including the time for reviewing instructions, searching existing data sources, gathering and maintaining the data needed, and completing and reviewing the collection of information. Send comments regarding this burden estimate or any other aspect of this collection of information, including suggestions for reducing this burden, to Washington Headquarters Services, Directorate for Information Operations and Reports, 1215 Jefferson Davis Highway, Suite 1204, Arlington VA 22202-4302. Respondents should be aware that notwithstanding any other provision of law, no person shall be subject to a penalty for failing to comply with a collection of information if it does not display a currently valid OMB control number.

1. REPORT DATE <b>APR 2014</b>		2. REPORT TYPE		3. DATES COVERED <b>00-00-2014 to 00-00-2014</b>	
4. TITLE AND SUBTITLE <b>Probability of Failure of Damaged Ship Structures - Phase 3</b>				5a. CONTRACT NUMBER	
				5b. GRANT NUMBER	
				5c. PROGRAM ELEMENT NUMBER	
6. AUTHOR(S)				5d. PROJECT NUMBER	
				5e. TASK NUMBER	
				5f. WORK UNIT NUMBER	
7. PERFORMING ORGANIZATION NAME(S) AND ADDRESS(ES) <b>Martec Limited,1888 Brunswick Street, Suite 400,Halifax, Nova Scotia, B3J 3J8,</b>				8. PERFORMING ORGANIZATION REPORT NUMBER	
9. SPONSORING/MONITORING AGENCY NAME(S) AND ADDRESS(ES)				10. SPONSOR/MONITOR'S ACRONYM(S)	
				11. SPONSOR/MONITOR'S REPORT NUMBER(S)	
12. DISTRIBUTION/AVAILABILITY STATEMENT <b>Approved for public release; distribution unlimited</b>					
13. SUPPLEMENTARY NOTES					
14. ABSTRACT					
15. SUBJECT TERMS					
16. SECURITY CLASSIFICATION OF:			17. LIMITATION OF ABSTRACT	18. NUMBER OF PAGES	19a. NAME OF RESPONSIBLE PERSON
a. REPORT <b>unclassified</b>	b. ABSTRACT <b>unclassified</b>	c. THIS PAGE <b>unclassified</b>			

This page intentionally left blank.

## Abstract

---

The methodology developed in Phase II for assessing the reliability of damaged ships is applied to a damaged ex-HMCS Nipigon. The midship section of the vessel is used in the analysis. The statistics of the maximum damaged length and the maximum penetration depths are determined with SIMCOL and COMPASS. Operational profiles for the damaged vessel are defined and WAVELOAD is used to compute the response amplitude operators, RAOs, of the waves on the vessel. The extreme values of the wave loads are also calculated and calibrated, and TRIDENT is used to estimate the still water bending moments. The ultimate bending moment capacities of the intact and the damaged vessel are calculated using ULTMAT. The damage size feature of ULTMAT is used to estimate the ultimate bending moment capacities interaction curves for damage sphere sizes of 2 m 3 m, 4 m, 5 m, and 6 m. These values are then used to determine the mean values, standard deviations and interaction coefficients for the damaged vessel. The linear and interaction equations limit state functions are defined and employed in COMPASS to estimate the reliabilities and the important factors of the random variables. Both the first order reliability method, FORM, and the Monte Carlo Simulation method, MCS, are used.

The result of the analyses indicate that for the selected operational profile defined by the computed wave loads, and the vessel ultimate bending moment capacities and a specified limit state function, the probability of failure of the damaged vessel is always higher than that of the intact vessel. Estimates of the damaged ship failure probabilities from the interaction curve models are always smaller than the linear models. This is because the linear model uses only the vertical components of bending loads on the ship, which are large, and the ship capacity, which is small. The modulating or interacting effects of the horizontal components of the bending loads, which are small, and the ship capacity, which is large, are neglected in the linear model. Therefore any result obtained from the linear model will be conservative, thus underscoring the need to use the better quality interaction model when performing deterministic and reliability analysis on damaged ships.

Uncertainties in three parameters, the vertical wave bending moment, the ultimate vertical bending moment capacity and the modelling uncertainty factor of the vertical wave bending moment, govern the estimates of the interaction equation model based damaged vessel reliability while uncertainties in four parameters, the vertical wave bending moment, the modelling uncertainty factor of the ultimate vertical bending moment capacity, the ultimate vertical bending moment capacity and the modelling uncertainty factor of the vertical wave bending moment drive the estimates from the linear model. In both cases, the dominant parameter that drives failure is the vertical wave bending moment. This is followed by the ultimate vertical bending moment capacity, and the modelling uncertainty factor for the ultimate vertical bending moment capacity when using the interaction and the linear limit state functions respectively. The full impact of the horizontal loads and capacities is not captured in the current analysis because of the limitations of the tools used to estimate the wave loads on the damaged vessel. The results underscore the need for appropriate models and tools when estimating the reliability of ships.

This page intentionally left blank.

## Executive summary

---

### Probability of Failure of Damaged Ship Structures – Phase 3

**Introduction or background:** Gross damage, such as that resulting from accidents or combat, affects both the structural and watertight integrity of surface ships. Moreover, a damaged ship may have to operate for a period of time with reduced structural strength and altered loading and stability characteristics, if only to get to a port of safety for repairs. The probability of survival of a damaged ship operating in a seaway is of considerable interest both in the immediate response to a damage incident and in ship design. Many uncertainties arise, both in the extent of gross damage that occurs during accidents or combat, as well as in the resulting strength and loading of a ship in a damaged condition. The present study is phase 3 of a larger study with the goal of demonstrating an assessment method for determining probability of failure in a damaged condition that properly accounts for uncertainties that arise during a damage incident

**Results:** The Phase 3 report is a presentation of the application to the midship section of ex-HMCS Nipigon of the methodology developed in Phase II for assessing the reliability of damaged ships. Five tools were used in the analysis, SIMCOL, WAVELOAD, TRIDENT, ULTMAT and COMPASS. SIMCOL and COMPASS were used to compute the mean values and the standard deviations of the maximum damaged length and the maximum damaged penetration depth. WAVELOAD was used to estimate the response amplitude operators, RAOs, and the extreme values of the wave loads were calculated and calibrated using COMPASS. TRIDENT was used to estimate the still water bending moment on the vessel. The ultimate strength of the intact and the damaged vessel were computed using ULTMAT. The damage size feature of ULTMAT was used to estimate the ultimate strength interaction curves for damage sphere sizes of 2 m, 3 m, 4 m, 5 m, and 6 m. COMPASS was then used to calibrate the mean values, the standard deviations and the interaction coefficients of the ultimate strength of the damaged vessel. Two limit state functions, linear and interaction equations were used in COMPASS to estimate the reliabilities of the damaged ship and the important factors of the random variables. The results of the analyses indicate that the probability of failure of the damaged ship is always higher than that of the intact vessel. Estimates of the damaged ship failure probabilities from the interaction curve models are always smaller than the linear models. This is because the linear model uses only the vertical components of bending loads on the ship and ship capacity. The modulating effects of the horizontal components of the bending loads and the ship capacity are neglected. For both the interaction and the linear limit state functions, the vertical wave bending moment is the dominant parameter that drives vessel failure. The results underscore the need to use appropriate limit state models and accurate estimates of parameters when describing the structural integrity of ship.

**Significance:** The demonstrated methodology can be applied to investigate the reliability of vessels that are currently in service or under development in the intact or damaged state.

**Future plans:** Additional work is anticipated with a case study that overcomes some of the limitations of the current tools and investigates the sensitivities of the response.

This page intentionally left blank.

# Table of contents

---

Abstract .....	i
Executive summary .....	iii
Table of contents .....	v
List of figures .....	vii
List of tables .....	x
1 Introduction .....	1
1.1 Background.....	1
1.2 Objectives and Scope .....	2
1.3 Organization of this Document.....	3
2 Summary of Overall Methodology and Definition of Vessel Characteristics .....	4
2.1 Summary of Overall Methodology.....	4
2.2 Description of Selected Vessel.....	5
2.3 A Review of Approaches and Tools Used in the Study .....	7
2.3.1 Approach and Tools Used to Estimate the Damage Sizes .....	7
2.3.2 Approaches and Tools Used to Estimate the Loads on the Damaged Ship.....	8
2.3.3 Approach and Tools Used to Estimate the Ultimate Strength of the Damaged Ship .....	9
2.3.4 Approach and Tool Used to Estimate the Reliability of the Damaged Ship...	9
3 Reliability Assessment of the Intact Vessel.....	13
3.1 Introduction .....	13
3.2 Estimates of the Loads On the Intact Vessel .....	13
3.2.1 Operational Profile.....	13
3.2.2 Still Water Bending Moment .....	14
3.2.3 Wave-Induced Bending Moment .....	17
3.2.3.1 RAO of Wave Loads on the Midship Section .....	17
3.2.3.2 Extreme Value of the Wave Loads on the Midship Section.....	23
3.3 Estimates of the Ultimate Strength of the Intact Vessel .....	26
3.4 Estimates of the Reliability of the Intact Vessel.....	31
4 Reliability Assessment of the Damaged Ship.....	41
4.1 Introduction .....	41
4.2 Damage Definition .....	41
4.3 Estimates of the Loads On the Damaged Ship .....	42
4.3.1 Operational Profile.....	42
4.3.2 Still Water Bending Moment .....	43

4.3.3	Wave-Induced Bending Moment .....	43
4.3.3.1	RAO of the Damaged Section .....	43
4.3.3.2	Extreme Value of Wave Loads on the Damaged Ship .....	44
4.4	Estimates of the Ultimate Strength Capacities of the Damaged Ship.....	47
4.5	Estimates of the Reliabilities of the Damaged Ship .....	53
4.5.1	Comparison of Estimates of Reliabilities for the Damaged and the Intact Vessel .....	64
5	Summary, Conclusions and Recommendations.....	70
5.1	Summary.....	70
5.1.1	Estimates of the Loads on the Intact and the Damaged Ship .....	70
5.1.2	Estimates of the Capacities of the Intact and the Damaged Ship.....	71
5.1.3	Estimates of the Reliabilities of the Intact and the Damaged Ship .....	72
5.2	Conclusions .....	73
5.3	Recommendations .....	74
References	.....	75
Annex A ..	Summary of the Importance Factors of the Random Variable Used in the Intact Ship Reliability Analysis .....	76
Annex B...	Summary of the Importance Factors of the Random Variable Used in the Damaged Ship Reliability Analysis .....	80

## List of figures

---

Figure 1: Overall Methodology for Estimating Probability of Failure of a Damaged Ship. ....	4
Figure 2: The Annapolis Class Destroyer HMCS Nipigon .....	5
Figure 3: Finite Element Model of the Ship .....	6
Figure 4: Vertical Still Water Bending Moment of the Midship Section of the Intact Vessel .....	15
Figure 5: Horizontal Still Water Bending Moment of the Midship Section of the Intact Vessel..	15
Figure 6: Still Water Vertical Shear Force of the Midship Section of the Intact Vessel.....	16
Figure 7: Still Water Horizontal Shear Force of the Midship Section of the Intact Vessel.....	16
Figure 8: Still Water Torsion of the Midship Section of the Intact Vessel .....	17
Figure 9: RAOs of the Vertical Bending Moment on the Midship Section of the Intact Vessel (a) 3 knots, (b) 12 knots .....	18
Figure 10: RAOs of the Horizontal Bending Moment on the Midship Section of the Intact Vessel (a) 3 knots, (b) 12 knots.....	19
Figure 11: RAOs of the Vertical Shear force on the Midship Section of the Intact Vessel (a) 3 knots, (b) 12 knots.....	20
Figure 12: RAOs of the Horizontal Shear force on the Midship Section of the Intact Vessel (a) 3 knots, (b) 12 knots .....	21
Figure 13: RAOs of the Torsion on the Midship Section of the Intact Vessel (a) 3 knots, (b) 12 knots .....	22
Figure 14: Cumulative Distribution Function of the Extreme Vertical Bending Moment on the Midship of the Intact Vessel.....	23
Figure 15: Cumulative Distribution Function of the Extreme Horizontal Bending Moment on the Midship of the Intact Vessel.....	24
Figure 16: Cumulative Distribution Function of the Extreme Vertical Shear Force on the Midship of the Intact Vessel.....	25
Figure 17: Cumulative Distribution Function of the Extreme Torsion on the Midship of the Intact Vessel.....	25
Figure 18: The Ultimate Bending Moment Capacities Interaction Curve of the Midship Section of the Intact Vessel.....	26
Figure 19: Normalized Ultimate Bending Moment Capacities Interaction Curve of the Midship Section of the Intact Vessel (FE Calibrated Load shortening Curve).....	27
Figure 20: Normalized Ultimate Bending Moment Capacities Interaction Curve of the Midship Section of the Intact Vessel (IACS Load shortening Curve).....	28
Figure 21: The Importance Factors of the Random Variables in Case 1 Intact Vessel; 3 and 6 knots, IACS Interaction Curve (a) Interaction Equation Model (b) Linear Model .....	35

Figure 22: The Importance Factors of the Random Variables Case 2 Intact Vessel; 6 and 9 knots, IACS Interaction Curve (a) Interaction Equation Model (b) Linear Model .....	36
Figure 23: The Importance Factors of the Random Variables Case 3 Intact Vessel; 9 and 12 knots, IACS Interaction Curve (a) Interaction Equation Model (b) Linear Model .....	37
Figure 24: The Importance Factors of the Random Variables Case 1 Intact Vessel; 3 and 6 knots, FE Calibrated Interaction Curve (a) Interaction Equation Model (b) Linear Model .....	38
Figure 25: The Importance Factors of the Random Variables Case 2 Intact Vessel; 6 and 9 knots, FE Calibrated Interaction Curve (a) Interaction Equation Model (b) Linear Model .....	39
Figure 26: The Importance Factors of the Random Variables Case 3 Intact Vessel; 9 and 12 knots, FE Calibrated Interaction Curve (a) Interaction Equation Model (b) Linear Model .....	40
Figure 27: The Effect of the Vessels Speed on the RAOs of the Vertical Bending Moment.....	44
Figure 28: The Effect of Speed on the RAOs of the Horizontal Bending Moment .....	44
Figure 29: Cumulative Distribution Function of the Extreme Vertical Bending Moment on the Midship of the Damaged Vessel .....	45
Figure 30: Cumulative Distribution Function of the Extreme Horizontal Bending Moment on the Midship of the Damaged Vessel .....	46
Figure 31: Cumulative Distribution Function of the Extreme Vertical Shear Force on the Midship of the Damaged Vessel .....	46
Figure 32: Cumulative Distribution Function of the Extreme Torsion on the Midship of the Damaged Vessel.....	47
Figure 33: Interaction Curve of the Ultimate Strength of the Damaged Vessel Midship Section (a) Based on FE Calibrated load shortening Curve (b) Based On IACS load Shortening Curve.....	48
Figure 34: Ultimate Strength Interaction Curves of the Intact and Damaged Vessel Midship Section (a) Based on FE Calibrated Load Shortening Curve (b) Based On IACS load Shortening Curve.....	49
Figure 35 Average Ultimate Strength Interaction Curve of the Damaged Vessel Midship Section.....	49
Figure 36: Normalized Ultimate Strength Interaction Curves of the Midship Section of the Damaged Vessel (IACS Load shortening Curve) .....	50
Figure 37: Normalized Ultimate Strength Interaction Curves of the Midship Section of the Damaged Vessel (FE Calibrated Load shortening Curve) .....	51
Figure 38: The Importance Factors of the Random Variables in Case 1 Damaged Vessel; 3 and 6 knots, IACS Interaction Curve (a) Interaction Equation Model (b) Linear Model .....	58

Figure 39: The Importance Factors of the Random Variables in Case 2 Damaged Vessel; 6 and 9 knots, IACS Interaction Curve (a) Interaction Equation Model (b) Linear Model .....	59
Figure 40: The Importance Factors of the Random Variables in Case 3 Damaged Vessel; 9 and 12 knots, IACS Interaction Curve (a) Interaction Equation Model (b) Linear Model .....	60
Figure 41: The Importance Factors of the Random Variables in Case 1 Damaged Vessel; 3 and 6 knots, FE Calibrated Interaction Curve (a) Interaction Equation Model (b) Linear Model.....	61
Figure 42: The Importance Factors of the Random Variables in Case 2 Damaged Vessel; 6 and 9 knots, FE Calibrated Interaction Curve (a) Interaction Equation Model (b) Linear Model.....	62
Figure 43: The Importance Factors of the Random Variables in Case 3 Damaged Vessel; 9 and 12 knots, FE Calibrated Interaction Curve (a) Interaction Equation Model (b) Linear Model.....	63
Figure 44: Comparison of a Typical Importance Factor for the Random Variables Using Interaction Equation Model (IACS) (a) Damaged Vessel (b) Intact Vessel .....	66
Figure 45: Comparison of a Typical Importance Factor for the Random Variables Using Linear Equation Model (IACS) (a) Damaged Vessel (b) Intact Vessel.....	67
Figure 46: Comparison of a Typical Importance Factor for the Random Variables Using Interaction Equation Model (FE Calibrated) (a) Damaged Vessel (b) Intact Vessel.....	68
Figure 47: Comparison of a Typical Importance Factor for the Random Variables Using Linear Equation Model (FE Calibrated) (a) Damaged Vessel (b) Intact Vessel.....	69

## List of tables

---

Table 1: Summary of the Main Particulars of the Ship .....	6
Table 2: Summary of Possible Vessel Sections for Analysis .....	7
Table 3: Structural Particulars of the Striking Handysize Freighter Ship .....	7
Table 4: Destroyer Damage Statistics .....	8
Table 5: Summary of the Components of the Loads on a Damaged Ship.....	8
Table 6: Summary of the Components of the Ultimate Strengths of a Damaged Ship.....	9
Table 7: Summary of the Probabilistic Characteristics of the Random Variables Used in the Reliability Assessment.....	11
Table 8: Operational Profile of the Intact Vessel Used to Estimate the Wave Loads .....	14
Table 9: Summary of the Still Water Loads On the Intact Vessel used for Reliability Assessment.....	14
Table 10: Summary of the Extreme Wave Loads on the midship of the Intact Vessel .....	24
Table 11: Summary of the Ultimate Strengths and the Interaction Coefficient of the Midship of the Intact Vessel (IACS Load Shortening Curves).....	29
Table 12: Summary of the Ultimate Strengths and Interaction Coefficients of the Midship of the Intact Vessel (FE Calibrated Load Shortening Curves) .....	30
Table 13: Summary of the Probabilistic Characteristics of the Random Variables Used for the Reliability Assessment of the Intact Vessel .....	31
Table 14: Summary of the Probabilities of Failures of the Midship Section of the Intact Vessel Using the IACS Load Shortening Curves.....	33
Table 15: Summary of the Probabilities of Failures of the Midship Section of the Intact Vessel Using the FE Calibrated Load Shortening Curves.....	33
Table 16: Statistics of the Damage on the Midship Section.....	41
Table 17: The Operational Profile of the Damaged Vessel.....	42
Table 18: Summary of the Still Water Loads on the Damaged Ship.....	43
Table 19: Summary of the Extreme Wave Loads on the Mid-Section of the Damaged Ship .....	45
Table 20: Summary of the Ultimate Strength and the Interaction Coefficients of the Damaged Vessel Mid-Section (IACS Load Shortening Curves) .....	52
Table 21: Summary of the Ultimate Strength and the Interaction Coefficients of the Damaged Vessel Mid-Section (FE Calibrated Load Shortening Curves) .....	53
Table 22: Summary of the Probabilistic Characteristics of the Random Variables Used for the Reliability Assessment of the Damaged Vessel.....	54
Table 23: Summary of the Probabilities of Failures of the Midship Section of the Damaged Vessel Using IACS Load Shortening Curves.....	56

Table 24: Summary of Probabilities of Failures of the Midship Section of the Damaged Vessel Using FE Calibrated Load Shortening Curves .....	56
Table 25: Comparison of the Probabilities of Failures of the Intact and the Damaged Vessel Using IACS Load Shortening Curves .....	65
Table 26: Comparison of the Probabilities of Failures of the Intact and the Damaged Vessel Using FE Calibrated Load Shortening Curves .....	65
Table 27: Summary of the Extreme Wave Loads on the Intact and the Damaged Ship .....	70
Table 28: Summary of the Still Water Loads on the Intact and the Damaged Ship .....	71
Table 29: Summary of the Ultimate Strength Capacities of the Intact and the Damaged Ship.....	72
Table 30: Summary of the Structural Reliabilities of the Intact and the Damaged Ship.....	73
Table 31 Summaries of Importance Factors of the Random Variable Used In the Interaction Equation Limit State Model for the Intact Ship –IACS Model.....	76
Table 32 Summaries of Importance Factors of the Random Variable Used In the Linear Equation Limit State Model for the Intact Ship –IACS Model.....	77
Table 33 Summaries of Importance Factors of the Random Variable Used In the Interaction Equation Limit State Model for the Intact Ship –FE Calibrated Model.....	78
Table 34 Summaries of Importance Factors of the Random Variable Used In the Linear Equation Limit State Model for the Intact Ship –FE Calibrated Model.....	79
Table 35 Summaries of Importance Factors of the Random Variable Used In the Interaction Equation Limit State Model for the Damaged Ship –IACS Model.....	80
Table 36 Summaries of Importance Factors of the Random Variable Used In the Linear Equation Limit State Model for the Damaged Ship –IACS Model.....	81
Table 37 Summaries of Importance Factors of the Random Variable Used In the Interaction Equation Limit State Model for the Damaged Ship –FE Calibrated Model .....	82
Table 38 Summaries of the Importance Factors of the Random Variables Used In the Linear Equation Limit State Model for the Damaged Ship –FE Calibrated Model .....	83

This page intentionally left blank.

# 1 Introduction

---

## 1.1 Background

Both naval and commercial vessels may experience various forms of damage in normal service conditions or as a result of accidents. Typical kinds of damage incurred by commercial ships include fatigue cracking, corrosion, as well as indentation and rupture due to collision, grounding or heavy seas. In addition, naval vessels may also suffer combat-related blast, fragmentation, and ballistics damage. Assessing the survivability of ships in a damaged condition continues to be an active area of research that encompasses the loss of structural strength, changes to the loading and dynamic stability, damage control, and crew evacuation.

The proposed project addresses the following question: for a ship operating in a given seaway how does the presence of damage affect the probability of structural failure? Previous work by DRDC (e.g. the Improved Ship Structure Maintenance Management project) has generally been concerned with corrosion and fatigue cracking. The present work is concerned with the effect of gross damage to structure, such as may be caused by collisions, groundings, and explosive effects. Gross damage is more challenging to assess than corrosion or fatigue cracking for two reasons:.

- If the damage is at or below the waterline, flooding will occur and the loading on the structure may differ from the intact case
- Gross damage may cause not only a reduction in strength and stiffness, but may bring about modes of failure (e.g. grillage collapse of stiffened panels, shear failure of hull girders) that normally would not occur in intact ships.

The ability to assess the probability of failure with gross damage would allow ship designers to improve damage tolerance of new designs through assessment of likely damage scenarios. It would also give naval architects and engineers a tool to assess the risk of operating ships with damage, and would ultimately provide ship owners with improved availability of their vessels without compromising safety.

This study is the third of a three-phase effort whose purpose is to identify a general methodology for assessing the effects of gross damage on ship structural performance, and apply it to some typical scenarios. The three phases of work are structured as follows:

**Task 1:** Review literature and capabilities of available tools; estimate gross damage to large surface ships (commercial vessel or naval frigate) using simulations of collisions.

**Task 2:** Identify a general evaluation methodology for assessing probability of structural failure in an intact and damaged condition, based on available modeling and computational tools.

**Task 3:** Conduct a case study using the identified methodology to determine the probability of failure of a ship in an intact and damaged condition while operating in a seaway.

Phase 1 was completed in FY 09/10 (under Task 9 of Contract W7707-088100). Phase 2 was completed in FY 10/11 (under Task 15 of Contract W7707-088100). It was focused on developing a methodology for reliability analysis of gross damage to ships and assessing the capabilities of available tools. The overall methodology developed involves six steps: (i) definition of ship characteristics and operation profile, (ii) determination of damage size and damage scenarios, (iii) estimation of loads on damaged ships, (iv) estimation of the ultimate strength of the damaged ship section, (v) estimation of the deterministic structural integrity of the damaged vessel; and (vi) estimation of the probabilistic reliability of the damaged vessel. Tools for assessing the extent of damage were discussed, and algorithms were proposed for computing and combining short term loads on a damaged ship, including still water and wave loads. A methodology was presented for analysing the residual strength of a damaged vessel that uses the simplified tool, ULTMAT, and TRIDENT. Formulas were developed in the form of interactive equations that define the safe envelope of operation, which can be used for deterministic structural integrity of a damaged vessel. Additionally, reliability analysis methods were developed that account for uncertainties in the loading, structural strength and models used for assessing a damaged vessel. Gaps in available tools and procedures were identified and documented.

## 1.2 Objectives and Scope

The overall objective of the study is to develop methodologies for assessing the probability of failure of damaged ship structures with gross damage. The present study is focused on Task 3 which is titled "Conduct a case study using the identified methodology to determine the probability of failure of a ship in an intact and damaged condition while operating in a seaway."

The scope includes:

- (i) Definition of vessel characteristics, loading conditions and damage scenarios.
  - Selection of a suitable ship design (non-active military or civilian) for which a structural and/or hydrodynamic model exists (eg Nipigon, Quest or a generic barge);
  - Definition of loading and damage conditions; and
  - Definition of short term duration for the damaged vessel to transit to safety.
- (ii) Reliability assessment of the intact vessel:
  - Computing and calibrating components of the loads for selected cross sections of the vessel, including still water bending moment (SWBM), and wave load bending moments (WLBM). This involves determining the statistical properties: the mean value, standard deviation and probability distributions, of the loads;
  - Performing probabilistic calibration of extreme wave loads for the transit duration and wave environment;
  - Computing and calibrating the ultimate strength interaction equations for selected cross sections of the vessel; and
  - Performing reliability assessment for the selected cross section using applicable limit states defined in Phase 2. Other items to be performed under this task include definition of random variables and determination of failure probabilities, sensitivities and importance factors.
- (iii) Reliability assessment of the damaged vessel:
  - Computing and calibrating components of the loads, still water bending moment (SWBM), and wave load bending moments (WLBM), for selected damaged cross

sections of the damaged ship. The damaged sizes used in the analyses are random variables with mean values and standard deviations;

- Performing probabilistic calibration of extreme wave loads for the transit duration and wave environment. This involves determining the statistical properties of the wave bending moments and forces;
- Computing and calibrating the ultimate bending moment strengths of selected cross sections of the damaged ship. This involves using the ultimate strength envelope to estimate the coefficients of the interaction equations for the sections;
- Performing reliability assessment for the selected cross section using applicable limit states defined in Phase 2. Other items to be performed under this task include definition of random variables and determination of failure probabilities, sensitivities and importance factors.

### **1.3 Organization of this Document**

Chapter 2 summarises the overall methodology for the reliability assessment and provides the definition of the vessel characteristics. A very brief review is presented of the approaches and the tools used for the analyses. Estimates are presented in Chapter 3 and Chapter 4 of the structural reliabilities of the intact and the damaged ex-HMC Nipigon ship respectively. Chapter 5 summarises the results of the study and provides recommendations for future work. A list is provided in Chapter 6 of the references used in the study. Summary is given in Annex A and Annex B of the importance factors of the random variables involved in the intact and the damaged vessels reliability assessments respectively.

## 2 Summary of Overall Methodology and Definition of Vessel Characteristics

### 2.1 Summary of Overall Methodology

The study uses the methodology shown in Figure 1 which was developed in Phase II.

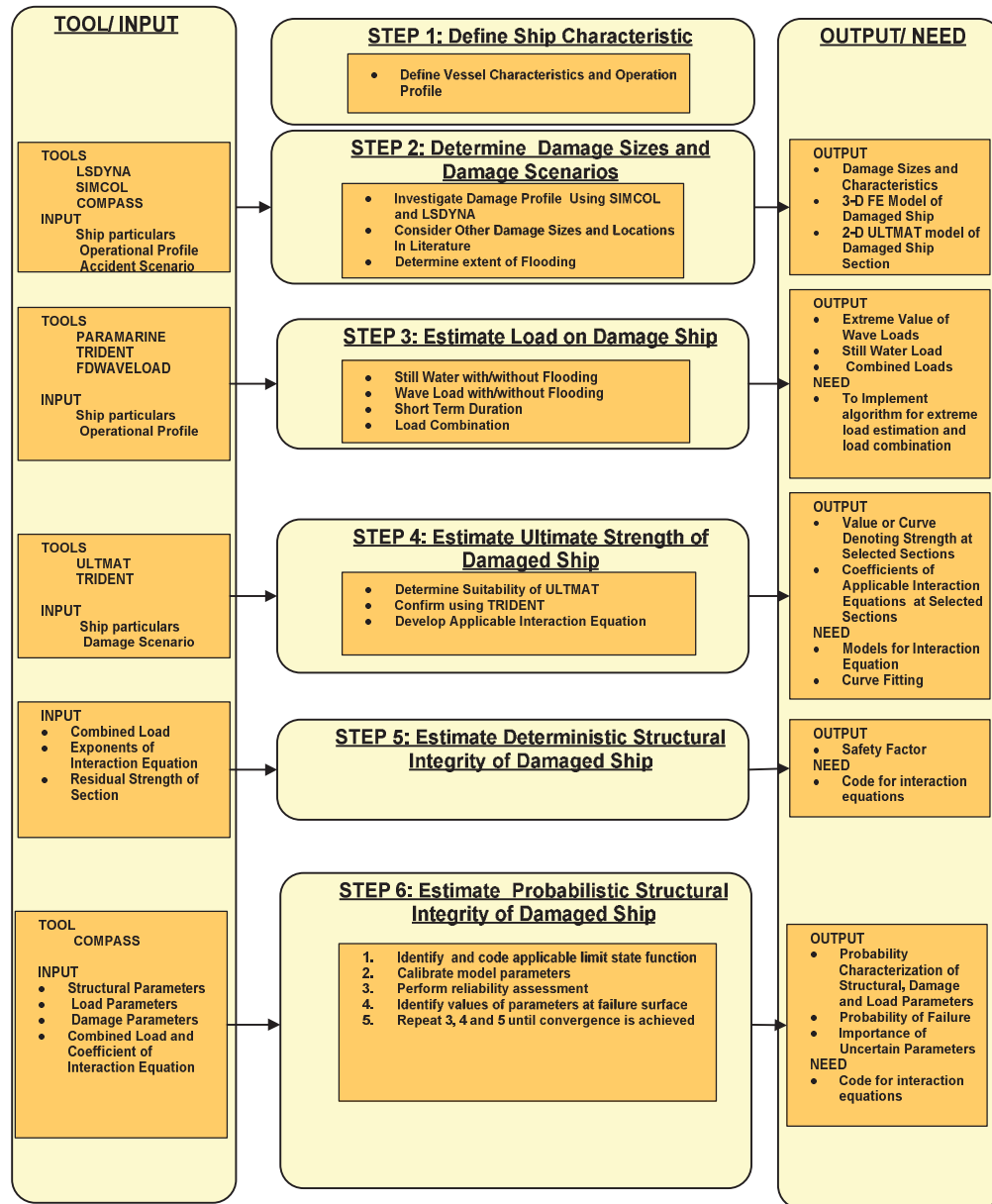

Figure 1: Overall Methodology for Estimating Probability of Failure of a Damaged Ship.

The methodology has six steps:

1. Definition of the ship characteristics and an operational profile. The main particulars of the ship under consideration and operational profile are defined and used to build the models;
2. Determination of the damage size and scenarios and development of suitable 3-D and/or 2-D model representations of the damaged vessel; Determination of the extent of flooding resulting from damage and the change in ship attitude (heel, trim) resulting from flooding;
3. Estimation of the loads on the damaged ships;
4. Estimation of the ultimate strengths of the damaged ship sections;
5. Estimation of the deterministic structural integrity of the damaged vessel using appropriate interaction equations; and
6. Estimation of the reliability of the damaged vessel.

The tools and the input parameters as well as the output and the limitations of the available tools are summarised in Figure 1. Although the methodology is developed for ship collision damage, it can be applied to other types of damage events as well.

## 2.2 Description of Selected Vessel

Figure 2 shows the ship that is used for the study. A finite element model of the vessel is shown in Figure 3. Its structural and hydrodynamics particulars are summarised in Table 1. She is a former Canadian naval vessel that was decommissioned in 1998.



*Figure 2: The Annapolis Class Destroyer HMCS Nipigon*

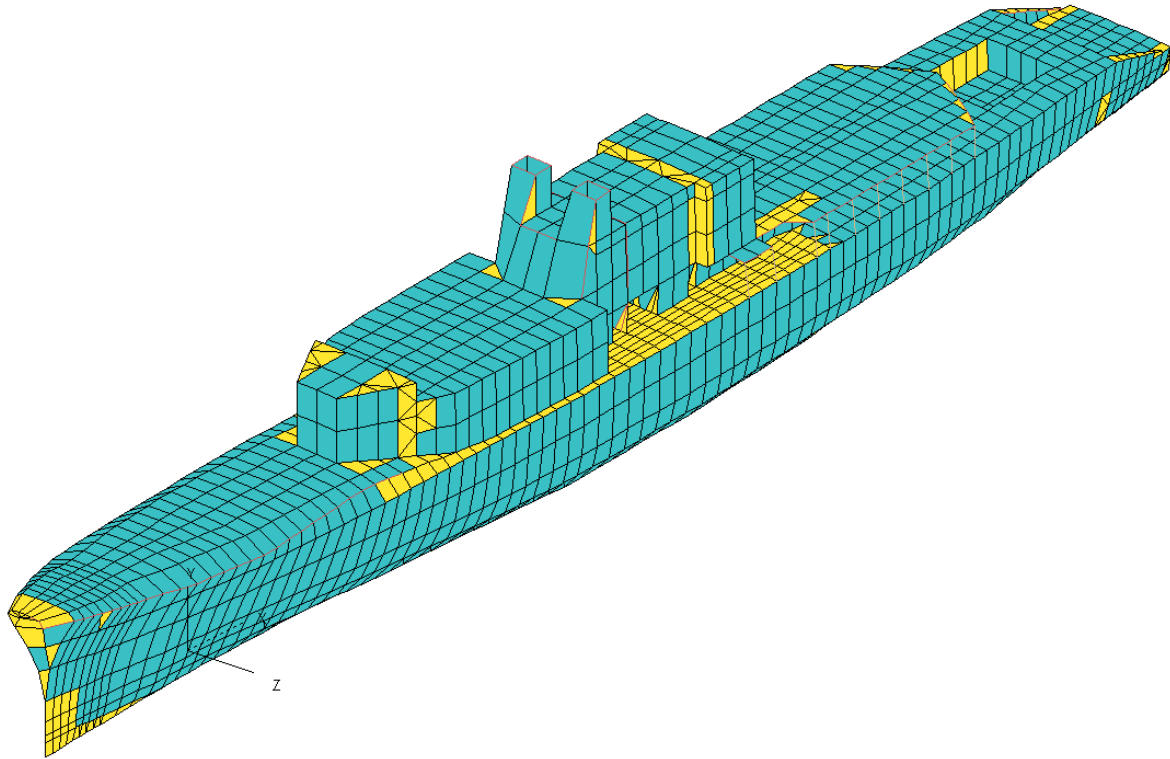

Figure 3: Finite Element Model of the Ship

Table 1: Summary of the Main Particulars of the Ship

Ship Particulars	Ship type	Destroyer
	Length between perpendiculars (m)	108.4
	Breadth (m)	12.75
	Depth (m)	20.04
	Draft (m)	5.18
	Displacement (kg)	$3.265 \times 10^6$
Number of transverse bulkheads		9
Locations of transverse bulkheads, measured from FP (m)		2.67, 6.93, 12.95, 24.38, 43.51, 68.20, 78.10, 81.76, 94.87
Number of longitudinal bulkheads		0
Smearred shell thickness (mm)		7.62
Smearred deck thickness (mm)		8.59
Smearred bottom thickness (mm)		9.52
Material grade for shell plating		Mild Steel

Table 2 provides a list of the vessel sections that can be used for structural integrity assessment. The current study uses the midship section of the vessel.

Table 2: Summary of Possible Vessel Sections for Analysis

Location	Distance from FP
Forward Quarter	2.74 m (1080 in)
Forward Midship	4.27 m (1680 in)
Midship	5.43 m (2136 in)
Aft Mid	6.78 m (2670 in)
Aft Quarter	8.14 m (3204 in)

## 2.3 A Review of Approaches and Tools Used in the Study

Detailed approaches and the tools for estimating the probability of failure of a damaged vessel were presented in Akpan et al., 2010 and Akpan et al 2011. To ensure completeness of the report, these approaches and tools are summarised briefly in this section

### 2.3.1 Approach and Tools Used to Estimate the Damage Sizes

The damage is assumed to be caused by collisions with a Handyman Dry Cargo Carrier. Realistic estimates of the damage sizes are obtained with two tools, SIMCOL and COMPASS. SIMCOL is used to calculate the maximum damaged length and the maximum damaged penetration depth during a ship collision event. It performs a two-fold analysis: external ship dynamics, to estimate collision forces and velocities, and internal ship deformations, to calculate the extent of the damage in the struck ship. The outputs from SIMCOL are fed into COMPASS to estimate the statistics and the probability characteristics of the damaged sizes. Table 3 gives the particulars of the striking vessel and the damage statistics are presented in Table 4.

Table 3: Structural Particulars of the Striking Handysize Freighter Ship

Striking Ship Particulars	Handysize Freighter
Length between perpendiculars (m)	150
Breadth (m)	20
Depth (m)	15
Draft (m)	7.5
Displacement (kg)	$10 \times 10^6$
Half entrance angle (degrees)	50

Table 4: Destroyer Damage Statistics

Location	Parameter	Mean Value	Standard Deviation
40 m from midship	Damaged Length (m)	4.0	3.6
	Maximum Penetration (m)	1.2	1.1
Midship	Damaged Length (m)	4.6	4.0
	Maximum Penetration (m)	1.6	1.5
-40 m from midship	Damaged Length (m)	4.0	3.6
	Maximum Penetration (m)	1.1	1.2

### 2.3.2 Approaches and Tools Used to Estimate the Loads on the Damaged Ship

The two main loads on a damaged ship are the still water and wave loads. The still water loads can be evaluated from proper consideration of the mass distribution over the ship length, the variability in the cargo loading and the buoyancy of the ship. The wave load can be determined from hydrodynamic analysis. The load parameters required for the reliability assessment of an intact and a damaged vessel are summarised in Table 5. The four steps and the tools used to compute the loads are as follow:

1. Use TRIDENT to estimate the components of the still water loads;
2. For a selected operational profile defined by the vessel's speed, heading and location, estimate the response amplitude operators, RAOs, of the components of the wave loads on the vessel using WAVELOAD.
3. Apply the methodology outlined in Chapter 5 (Akpan et. el. (2011)), which involves using the spectral moments of the wave loads for the various sea states to estimate the extreme values of the wave loads. Obtain the probability of occurrence of the extreme loads by combining the probability of occurrence of the speed, heading and sea states.
4. Use the probability of occurrence of the extreme loads to estimate the extreme statistics of the wave loads: mean values and standard deviations.
5. Combine the components of the still water and the wave loads with appropriate load combination factors.

Table 5: Summary of the Components of the Loads on a Damaged Ship.

Load	Component	Symbol
Still Water	Vertical Bending Moment	$M_{VSW}$
	Horizontal Bending Moment	$M_{HSW}$
	Torsional Bending Moment	$M_{TSW}$
	Vertical Shear Force	$F_{VSW}$
	Horizontal Shear Force	$F_{HSW}$
Wave Induced	Vertical Bending Moment	$M_{VW}$
	Horizontal Bending Moment	$M_{HW}$
	Torsional Bending Moment	$M_{TW}$

Load	Component	Symbol
	Vertical Shear Force	$F_{VSW}$
	Horizontal Shear Force	$F_{HSW}$

### 2.3.3 Approach and Tools Used to Estimate the Ultimate Strength of the Damaged Ship

The main components of the ultimate strength of a damaged ship are summarised in Table 6. ULTMAT, the 2-D progressive collapse tool is used to compute the ultimate strength of the damaged ship. Of the 5 components of the ultimate strength listed in Table 6, ULTMAT can only produce two components, the sectional vertical and horizontal bending moments. Therefore, the current analysis is limited to reliability assessments that involve only these two components.

Table 6: Summary of the Components of the Ultimate Strengths of a Damaged Ship.

Strength	Component	Symbol
Ultimate	Ultimate Vertical Bending Moment	$M_{VU}$
	Ultimate Horizontal Bending Moment	$M_{HU}$
	Ultimate Torsional Moment	$M_{TU}$
	Ultimate Vertical Shear force	$F_{VSU}$
	Ultimate Horizontal Shear force	$F_{HSU}$

For a selected cross section of the ship, the interaction curve analysis capability of ULTMAT is used to generate the envelope of the vertical bending moment and the horizontal bending moment structural strengths. A regression analysis and an optimization technique are then used to calibrate the interaction parameters,  $m$  and  $n$  defined in Equation 1 for the various quadrants of the interaction curves.

$$\left(\frac{y}{M_{VU}}\right)^n + \left(\frac{x}{M_{HU}}\right)^m = 1 \quad (1)$$

### 2.3.4 Approach and Tool Used to Estimate the Reliability of the Damaged Ship

Probabilistic structural reliability methods attempt to estimate the probability that an intact or a damaged vessel could fail during operation. The methods account for the various uncertainties associated with the models and the parameters. The first step in a reliability assessment is the definition of a performance or limit state function. The two performance functions used in the reliability assessment are Equations (2) and Equation (3). In the current study, Equations (2) will be referred to as the linear model and Equation (3) will be called the interaction equation model. The parameters in Equation (2) and (3) are defined in Table 7. One random variable that is not listed in Table 7 is the extent of damage. This is because it does not appear explicitly in Equations

(2) or (3). It is an implicit random variable that shows up in the estimates of the ultimate strength and the interaction coefficients of the damage ship.

$$g(X) = x_{VU} M_{VU} - x_{VSW} \Psi_V M_{VSW} - x_{VW} M_{VW} \quad (2)$$

$$g(X) = 1 - \left( \frac{x_{VSW} \Psi_V M_{VSW} + x_{VW} M_{VW}}{x_{VU} M_{VU}} \right)^n - \left( \frac{x_{HSW} \Psi_H M_{HSW} + x_{HW} M_{HW}}{x_{HU} M_{HU}} \right)^m \quad (3)$$

Once the limit state function is defined, the reliability of the vessel is the likelihood of it functioning according to its designed purpose. The failure probability is one minus the reliability. The reliability of the vessel can be computed using the limit state or performance functions  $g(X)$  defined in Equation (2) or Equation (3). The failure domain ( $\Omega$ ) is defined by a negative performance function (i.e.  $\Omega = [g(X) < 0]$ ), while its compliment ( $\Omega' = [g(X) > 0]$ ) defines the safe region. The failure probability is computed using Equation (4)

$$P_f = \int_{\Omega} f(X) dX \quad (4)$$

where  $f(X)$  denotes the joint probability density function of the basic random variables, X. COMPASS is used for the reliability assessment of the intact and the damaged ship. Several practical approaches for computing failure probabilities are available in COMPASS, including the first order reliability methods (FORM) and the Monte Carlo Simulation (MCS). These two methods are used in the study.

Identification of the main sources of uncertainty, which have significant influences on the reliability of a system, is carried out by computing probability sensitivity measures. This is an important part of reliability analysis which can be as significant as the calculation of failure probabilities. COMPASS has capabilities for computing several parameter sensitivity measures based on FORM results. The importance factors,  $\alpha_i$ , are used to determine the sources of uncertainties that drive failure.  $\alpha_i^2$  are computed.  $\alpha_i$  is given by

$$\alpha = \frac{\nabla g(U^*)}{|\nabla g(U^*)|} \quad (5)$$

where  $g$  is the limit state function,  $U^*$  is the most probable point in the standard normal space (u-space) and  $\nabla$  is the gradient operator. The u-space is defined by the mean value of the random variable divided by the standard deviation. Importance factors express the relative importance of the different sources of uncertainty associated with the basic random variables that define a problem.

Table 7: Summary of the Probabilistic Characteristics of the Random Variables Used in the Reliability Assessment.

Name	Mean Value	COV	Probability Distribution
Ultimate Vertical Bending Moment Capacity (kNm), $M_{VU}$	Depends on vessel condition, cross section etc.	Depends on vessel condition, cross section etc.	Weibull
Modelling Uncertainty Factor for Ultimate Vertical Bending Moment Capacity, $x_{VU}$	1	0.10	Normal
Vertical Wave Bending Moment (kNm), $M_{VW}$	Depends on operational profile, hull form, weight distribution etc.	Depends on operational profile, hull form, weight distribution etc.	Gumbel
Modelling Uncertainty Factor for Vertical Wave Bending Moment, $x_{VW}$	1	0.10	Normal
Vertical Still Water Bending Moment (kNm), $M_{VSW}$	Depends on vessel hull form, weight distribution etc.	0.10	Normal
Modelling Uncertainty Factor for Vertical Still Water Bending Moment $x_{VSW}$	1	0.10	Normal
Vertical Load Combination Factor, $\Psi_V$	1		Fixed
Ultimate Horizontal Bending Moment Capacity (kNm), $M_{HU}$	Depends on vessel condition, cross section etc.	Depends on vessel condition, cross section etc.	Weibull
Modelling Uncertainty Factor for Ultimate Horizontal Bending Moment Capacity, $x_{HU}$	1	0.10	Normal
Horizontal Wave Bending Moment (kNm), $M_{HW}$	Depends on operational profile, hull form, weight distribution etc.	Depends on operational profile, hull form, weight distribution etc.	Gumbel
Modelling Uncertainty Factor for Horizontal Wave Bending Moment, $x_{HW}$	1	0.10	Normal

Name	Mean Value	COV	Probability Distribution
Horizontal Still Water Bending Moment (kNm), $M_{HSW}$	Depends on vessel hull form, weight distribution etc.	Depends on Vessel	Normal
Modelling Uncertainty Factor Horizontal Still Water Bending Moment, $x_{HSW}$	1	0.10	Normal
Horizontal Load Combination Factor, $\Psi_H$	1		Fixed
Vertical Bending Moment Interaction Coefficient $m$	Depends on operational profile, hull form weight distribution etc.	Depends on operational profile, hull form weight distribution etc.	Fixed
Horizontal Bending Moment Interaction Coefficient $n$	Depends on operational profile, hull form weight distribution etc.	Depends on operational profile, hull form weight distribution etc.	Fixed

## 3 Reliability Assessment of the Intact Vessel

---

### 3.1 Introduction

The structural integrity of the intact ship is analyzed within a reliability framework. The steps used are

- Estimation and calibration of the loads on the intact vessel, that is, determining the mean values, standard deviations and probability distribution of the loads;
- Estimation and calibration of the capacities of the intact vessel, that is, determining the mean values, standard deviations and probability distribution of the capacities; and
- Estimation of the reliabilities of the intact vessel, that is, computing the probabilities of failures and the probabilistic sensitivities of the various random variables.

The reliability assessment is performed using the midship section of the ship.

### 3.2 Estimates of the Loads On the Intact Vessel

#### 3.2.1 Operational Profile

An operation profile for the vessel is defined by the loading condition, the vessel's speed and heading and the location typified by the sea state ( $T_z$ ,  $H_s$ ). Table 8 summarises the operational profile of the intact vessel. As seen in Table 8, the operational profile is divided into three vessel speed cases to allow for the assessment of the impact of the vessels speed on the structural integrity. The sea state condition can involve different spectra such as JONSWAP wave spectrum and Bretschneider wave spectrum. The Bretschneider spectrum used in the study is defined by

$$S_w = \frac{5H_s^2\omega_p^4}{16\omega^5} \exp\left[-1.25\left(\frac{\omega_p}{\omega}\right)^4\right] \quad (1)$$

Where  $\omega$  and  $\omega_p$  are the wave frequency and the modal or peak energy frequency respectively.

Table 8: Operational Profile of the Intact Vessel Used to Estimate the Wave Loads

		Vessel Speed (knots)	% Time Spent
<b>Case 1</b>		3	50
		6	50
<b>Case 2</b>		6	50
		9	50
<b>Case 3</b>		9	50
		12	50
Headings(Degrees)		% Time Spent	
0		5	
45		30	
90		20	
135		30	
180		15	
<b>Location: North Atlantic; Spectrum: Bretschneider (<math>H_s</math>, <math>T_z</math>)</b>			
$H_s$ (m)	$T_z$ (sec)	% Time Spent in Each State	
6.5	7.5	20	
4.5	7.5	40	
2.5	7.5	40	
Vessel Loading Condition - 3,474,900 kg			

### 3.2.2 Still Water Bending Moment

TRIDENT is used to estimate the still water bending moment on the intact ship. Figure 4 to Figure 8 are plots of the still water loads on the intact vessel. Since the structural integrity assessment of the vessel for the intact case is based on the midship section, only the values of the still water loads at this location are relevant to the current study. A summary of the applicable still water bending moments, vertical and horizontal, along with the assumed probability distribution and coefficient of variation, COV, is presented in Table 9. The other still water loads at the midship, torsion, vertical and horizontal shear forces, are not used in the reliability assessment because their corresponding values of the ship strengths cannot be estimated from the current version of ULTMAT.

Table 9: Summary of the Still Water Loads On the Intact Vessel used for Reliability Assessment

Name	Mean Value	COV	Probability Distribution
Vertical Still Water Bending Moment (kNm)	33534.22	0.1	Normal
Horizontal Still Water Bending Moment (kNm)	1643.32	0.1	Normal

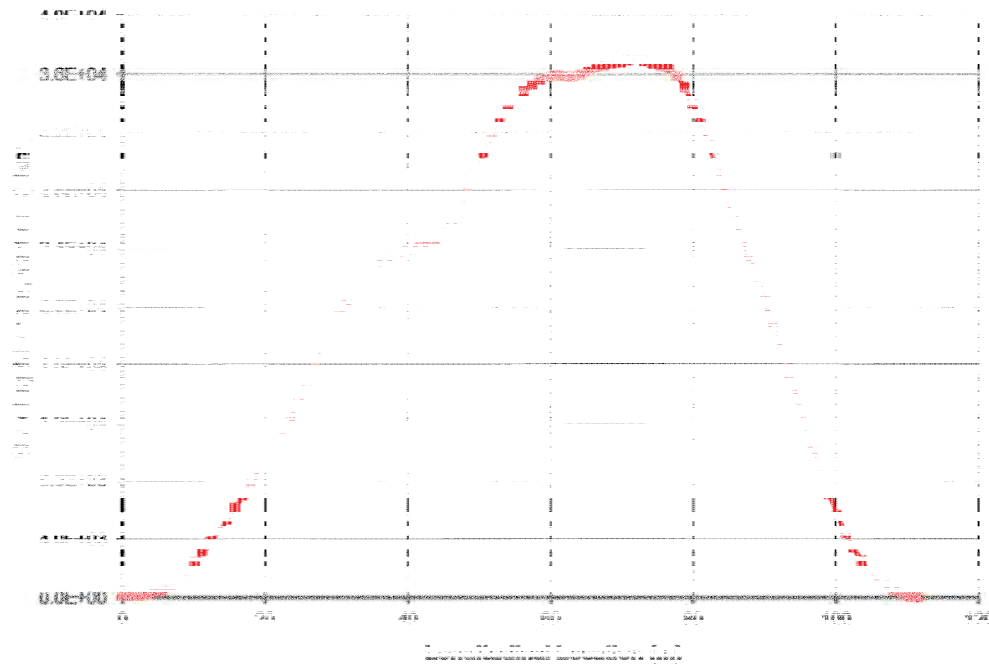

Figure 4: Vertical Still Water Bending Moment of the Midship Section of the Intact Vessel

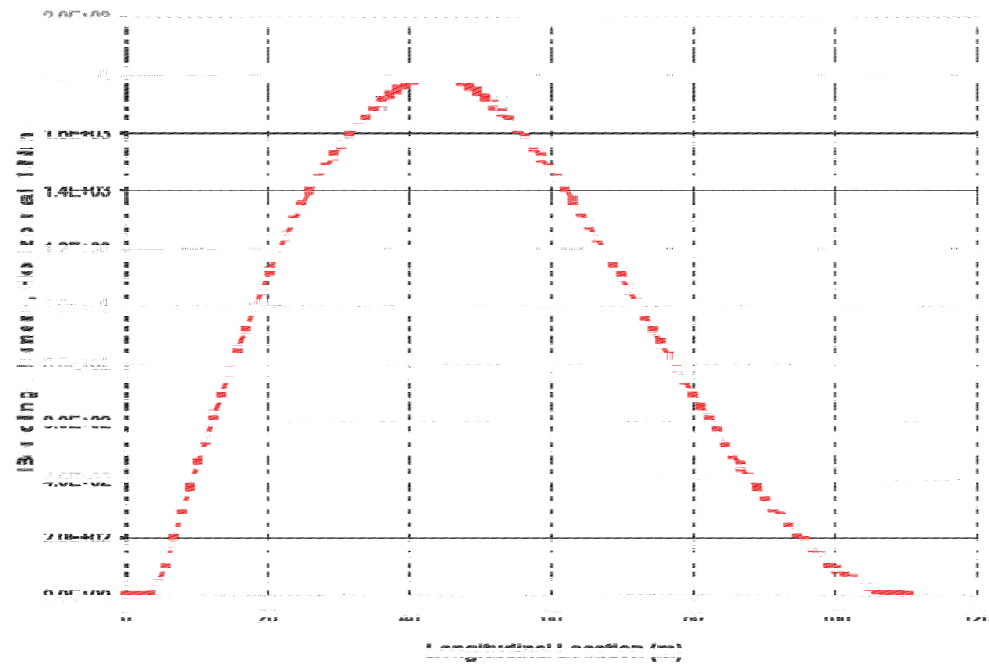

Figure 5: Horizontal Still Water Bending Moment of the Midship Section of the Intact Vessel

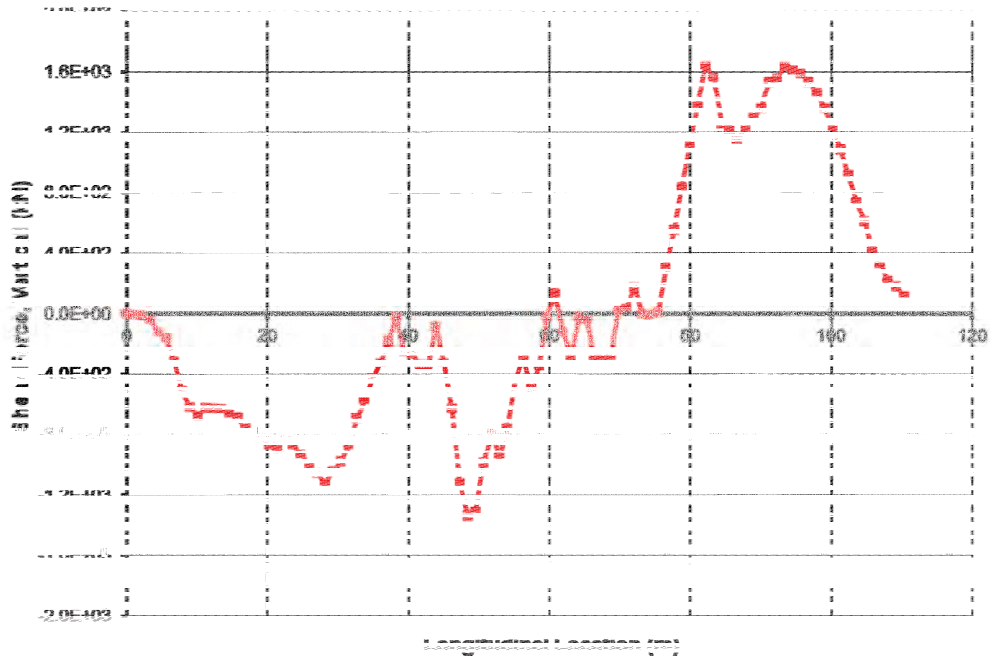

Figure 6: Still Water Vertical Shear Force of the Midship Section of the Intact Vessel

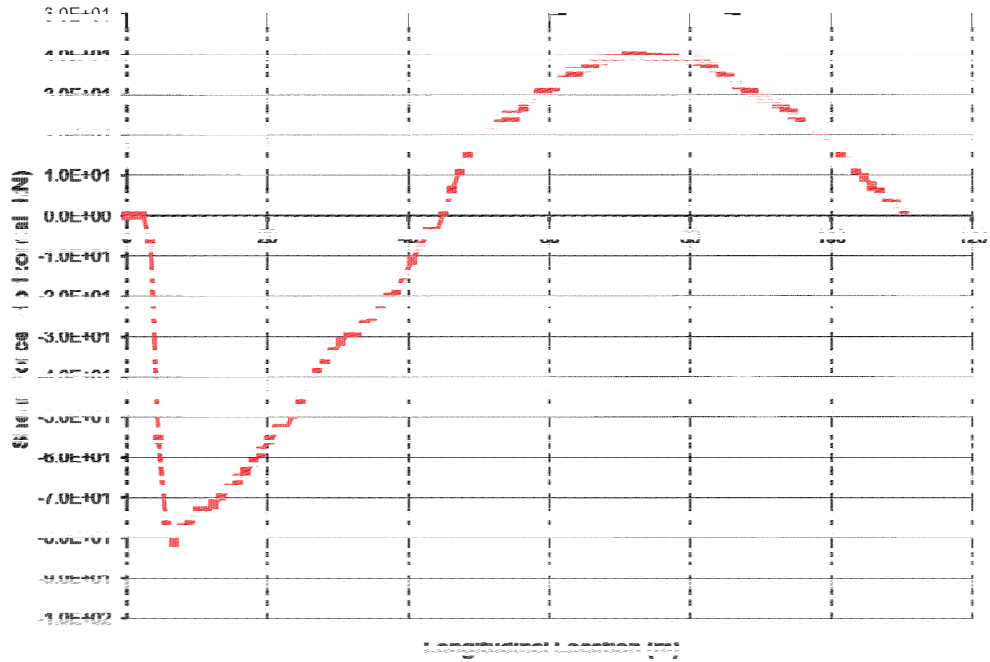

Figure 7: Still Water Horizontal Shear Force of the Midship Section of the Intact Vessel

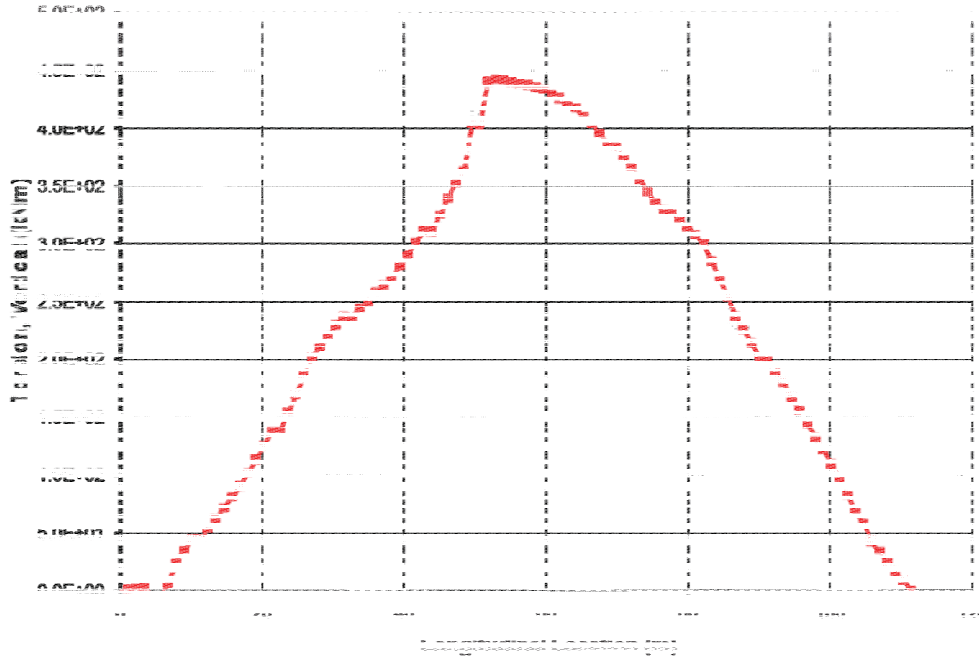
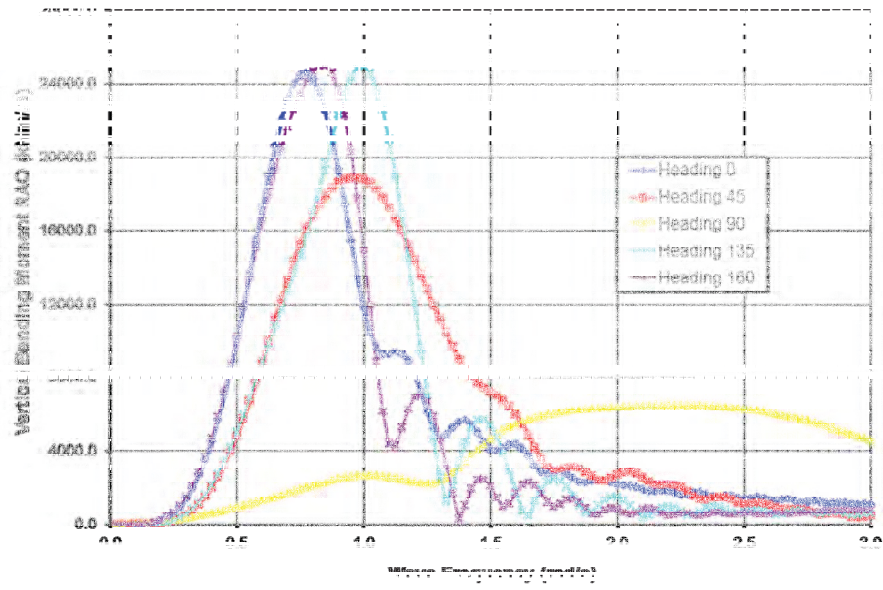

Figure 8: Still Water Torsion of the Midship Section of the Intact Vessel

### 3.2.3 Wave-Induced Bending Moment

#### 3.2.3.1 RAO of Wave Loads on the Midship Section

The response amplitude operators, RAOs, of the wave loads on the intact vessel sections are computed using WAVELOAD. Plots of the RAOs of the wave loads on the midship section are shown in Figure 9 to Figure 13. Similar RAOs were computed for the loads on the other sections of the vessel.



(a)

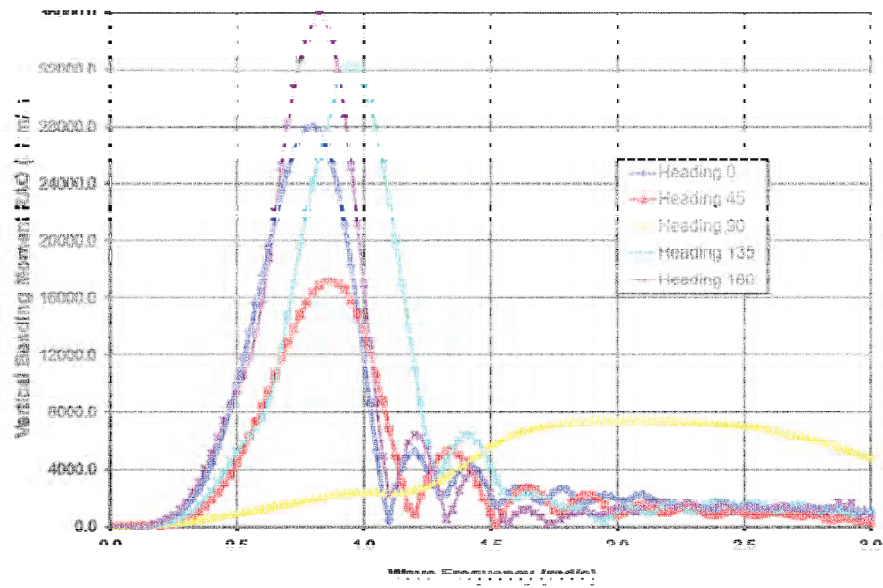

(b)

Figure 9: RAOs of the Vertical Bending Moment on the Midship Section of the Intact Vessel (a) 3 knots, (b) 12 knots

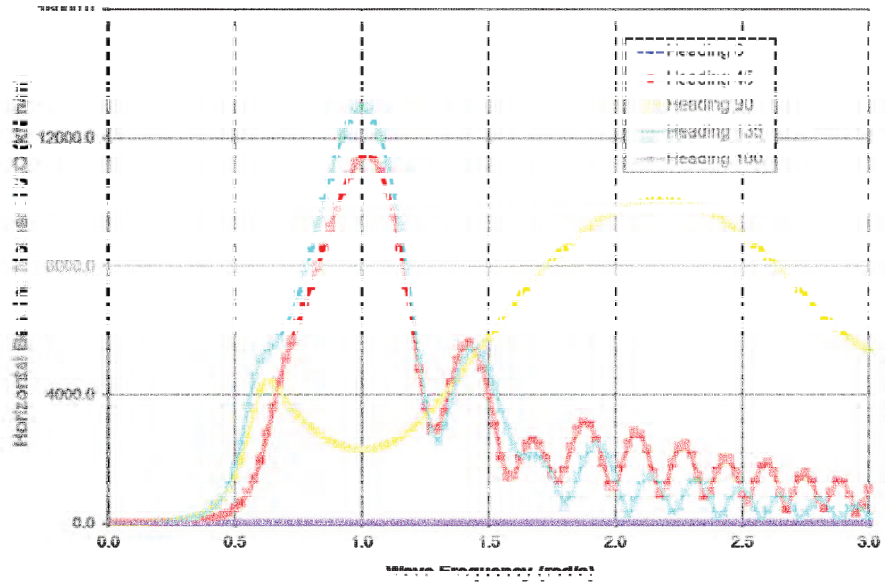

(a)

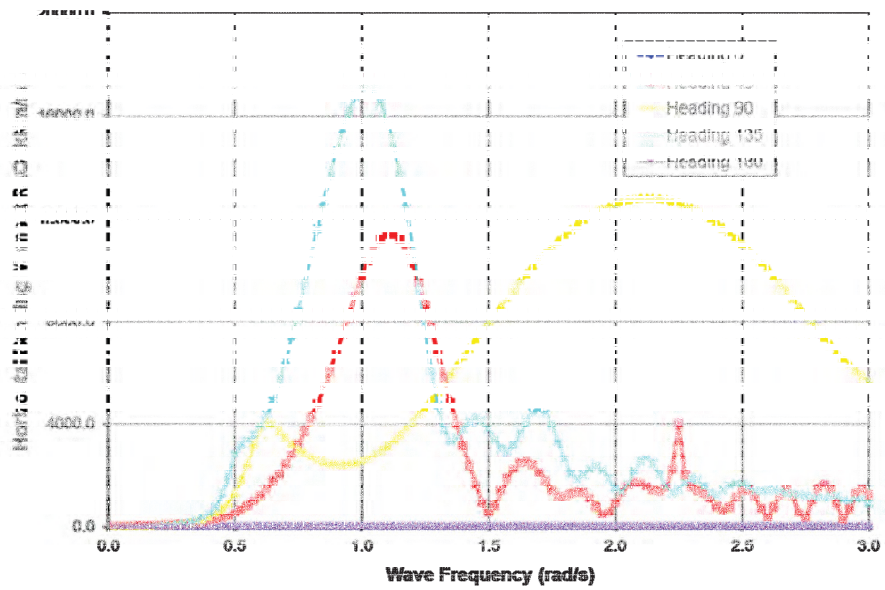

(b)

Figure 10: RAOs of the Horizontal Bending Moment on the Midship Section of the Intact Vessel  
 (a) 3 knots, (b) 12 knots

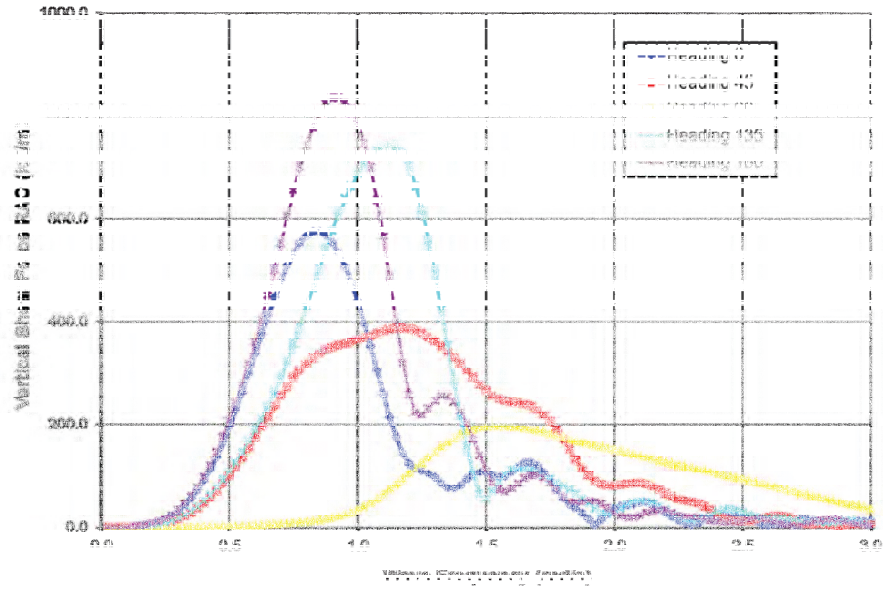

(a)

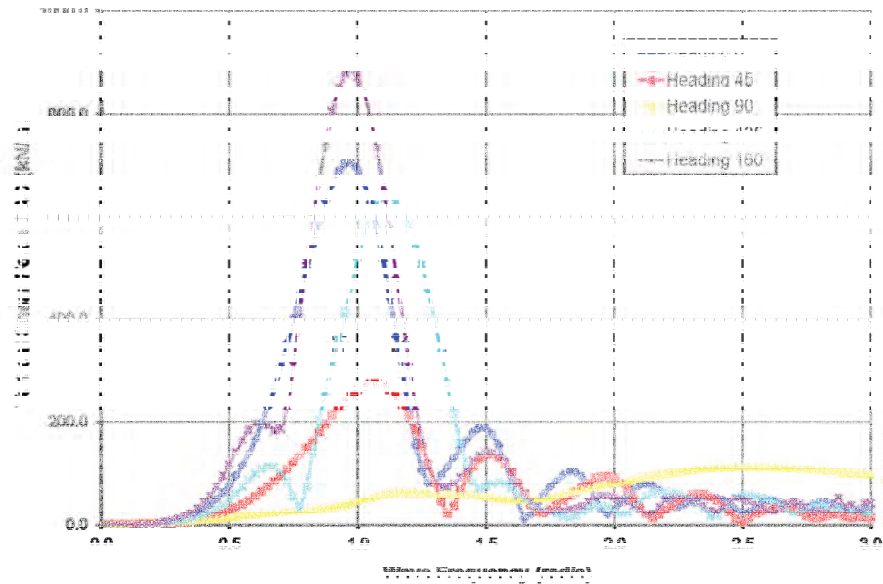

(b)

Figure 11: RAOs of the Vertical Shear force on the Midship Section of the Intact Vessel (a) 3 knots, (b) 12 knots

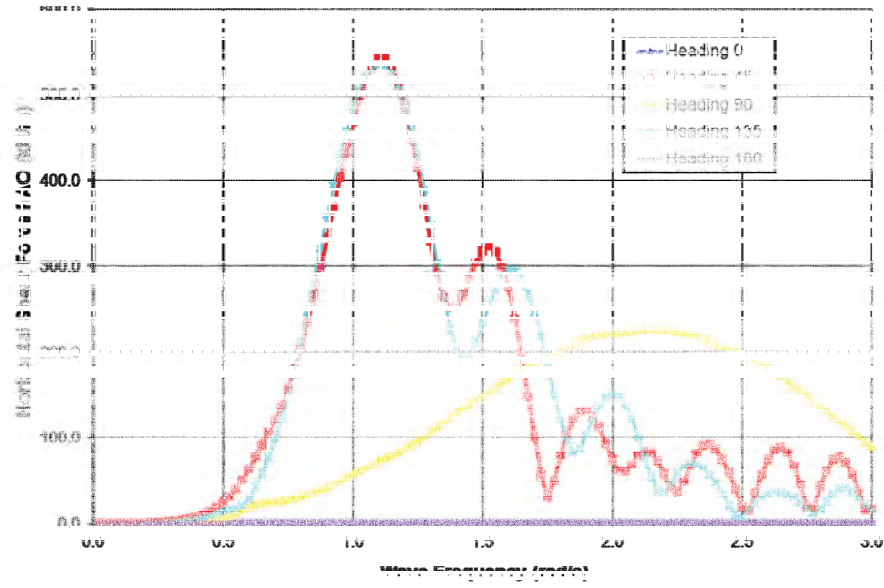

(a)

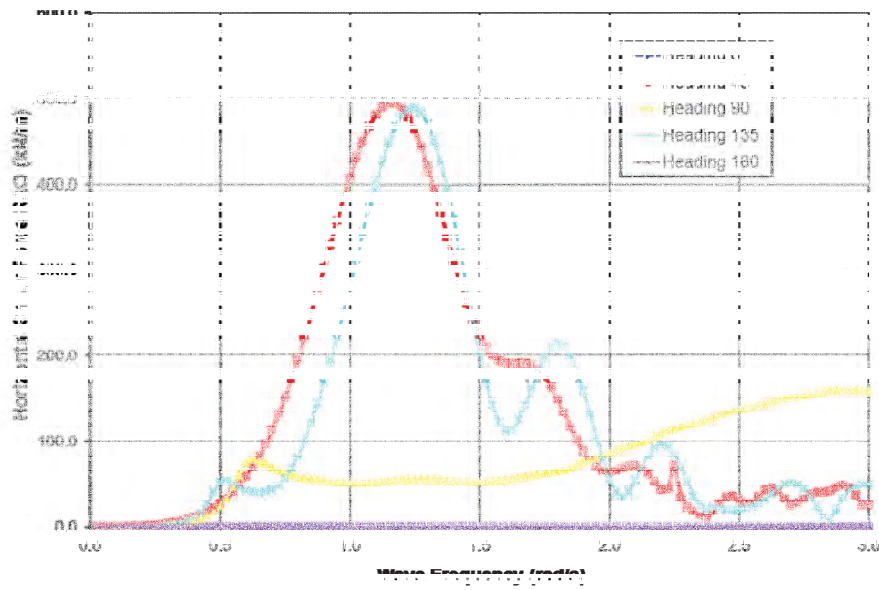

(b)

Figure 12: RAOs of the Horizontal Shear force on the Midship Section of the Intact Vessel (a) 3 knots, (b) 12 knots

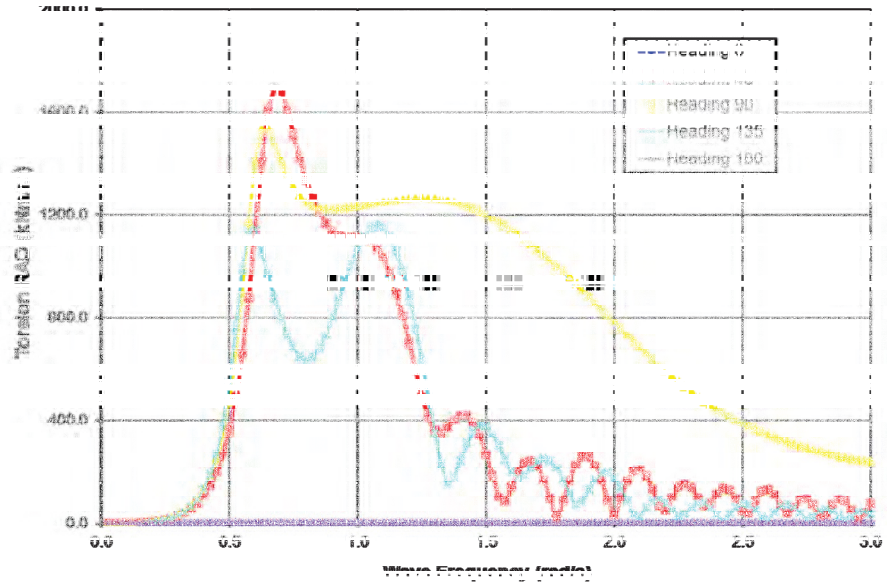

(a)

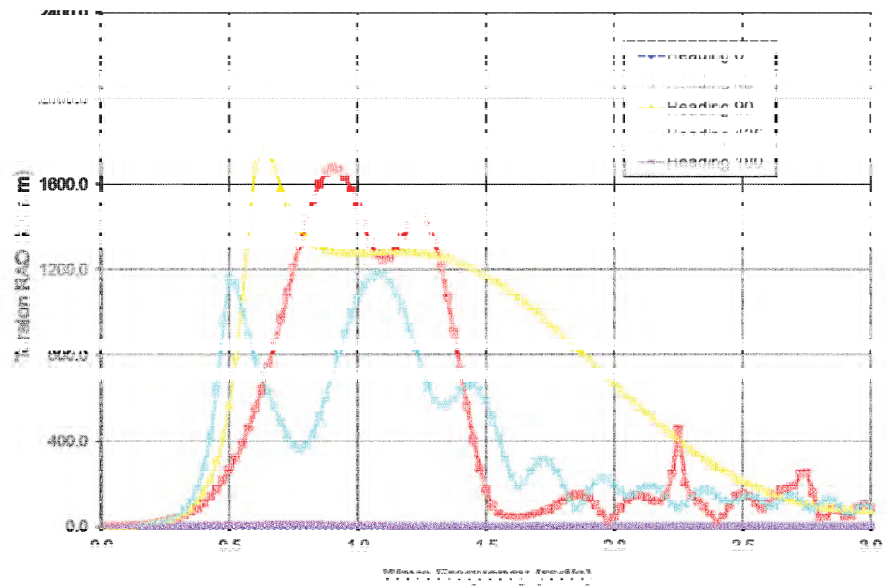

(b)

Figure 13: RAOs of the Torsion on the Midship Section of the Intact Vessel (a) 3 knots, (b) 12 knots

### 3.2.3.2 Extreme Value of the Wave Loads on the Midship Section

The extreme values of the wave loads on the midship section of the intact ship are computed using the operational profile defined in Table 8 and the RAOs of the loads presented in Figure 9 and Figure 10. It is assumed that Table 8 is representative of the operational profile that the vessel will experience during its lifetime. This is a limitation of the current analysis because the operational profile of the vessel during its lifetime will be different from Table 8. Probabilistic calibration of the extreme loads is performed with COMPASS. Figure 14 to Figure 17 show the cumulative distribution functions of the extreme vertical and horizontal bending moments for the 3 speed cases defined in Table 8, 3 and 6 knots; 6 and 9 knots; and 9 and 12 knots. The statistics of the extreme loads on midship section of the intact vessel are summarized in Table 10.

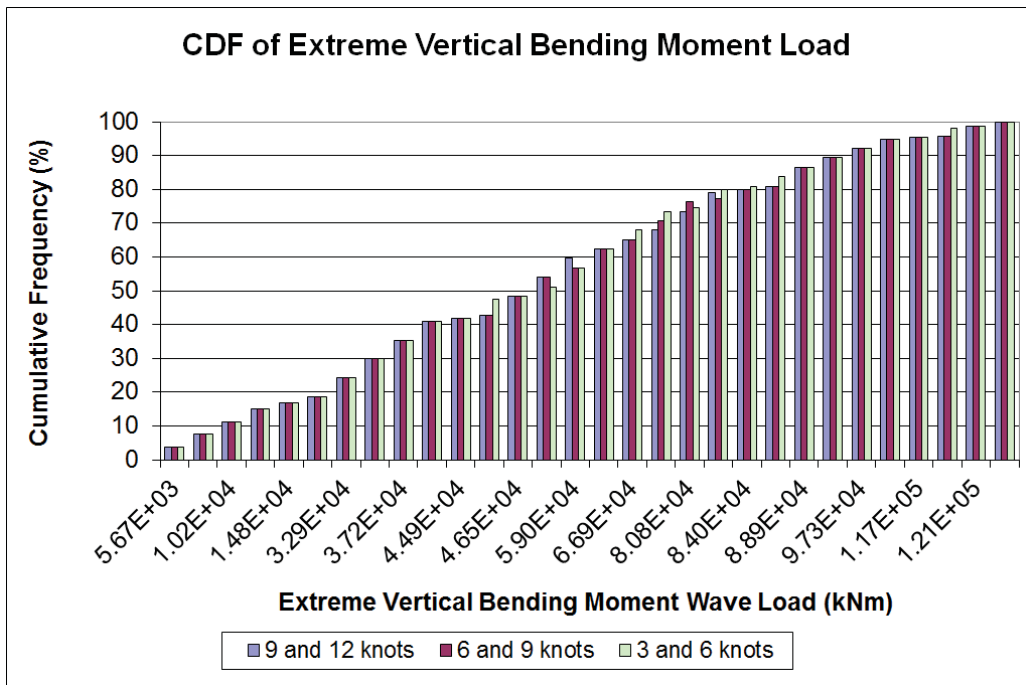

Figure 14: Cumulative Distribution Function of the Extreme Vertical Bending Moment on the Midship of the Intact Vessel

Table 10: Summary of the Extreme Wave Loads on the midship of the Intact Vessel

Load Case	Name	Mean Value	COV	Probability Distribution
3 and 6 knots	Vertical Wave Bending Moment (kNm)	53156.97	0.59	Gumbel
	Horizontal Wave Bending Moment (kNm)	18862.87	0.81	Gumbel
6 and 9 knots	Vertical Wave Bending Moment (kNm)	56303.25	0.61	Gumbel
	Horizontal Wave Bending Moment (kNm)	19328.98	0.83	Gumbel
9 and 12 knots	Vertical Wave Bending Moment (kNm)	57209	0.63	Gumbel
	Horizontal Wave Bending Moment (kNm)	18834	0.85	Gumbel

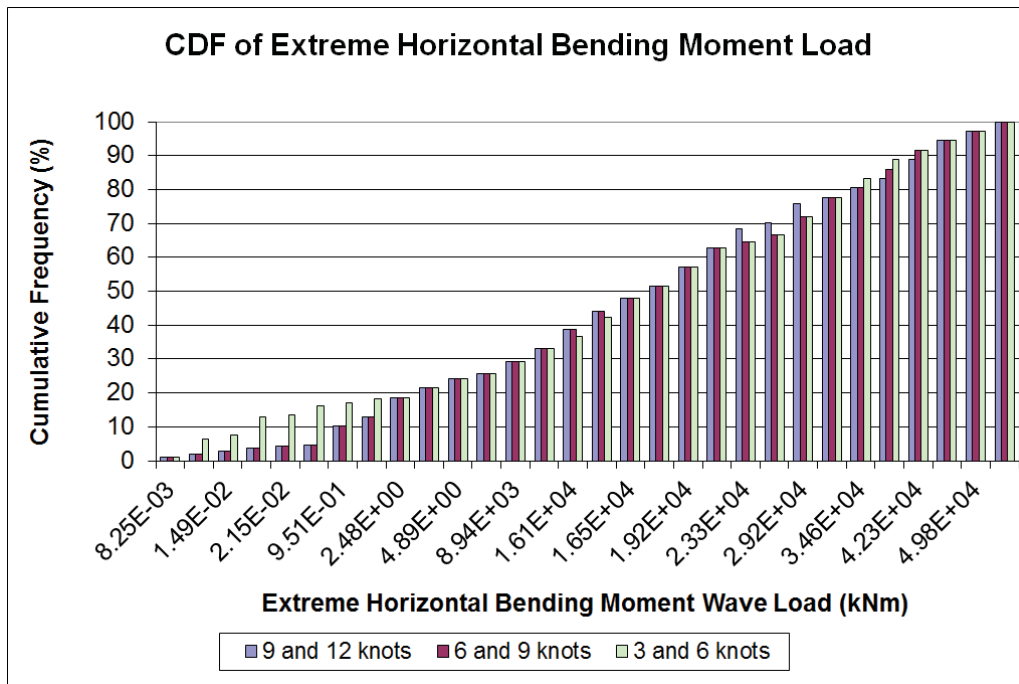

Figure 15: Cumulative Distribution Function of the Extreme Horizontal Bending Moment on the Midship of the Intact Vessel

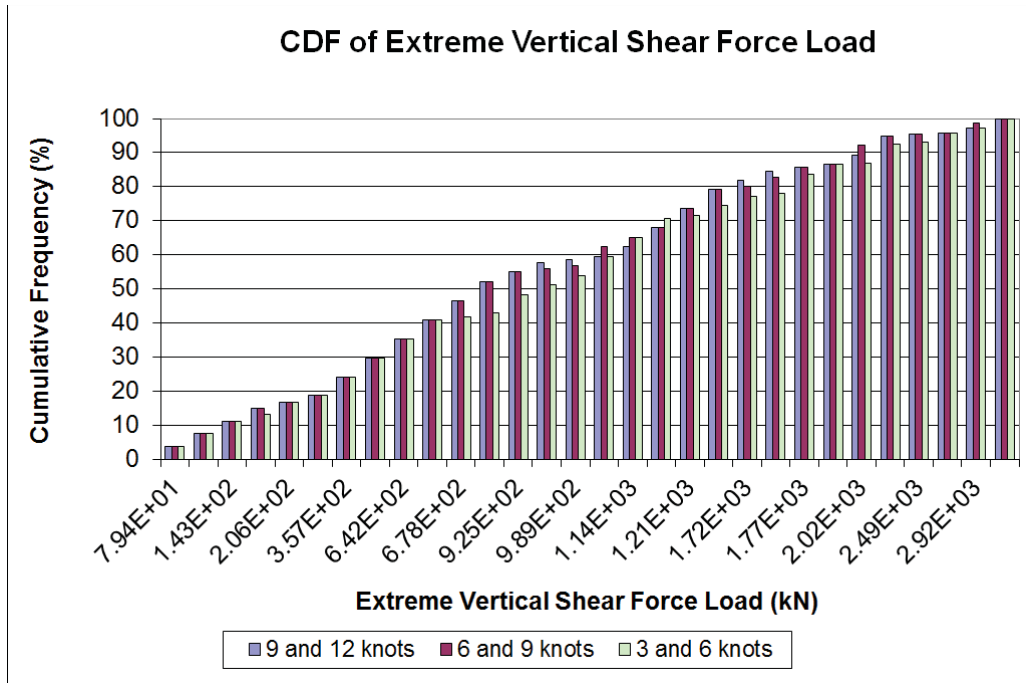

Figure 16: Cumulative Distribution Function of the Extreme Vertical Shear Force on the Midship of the Intact Vessel

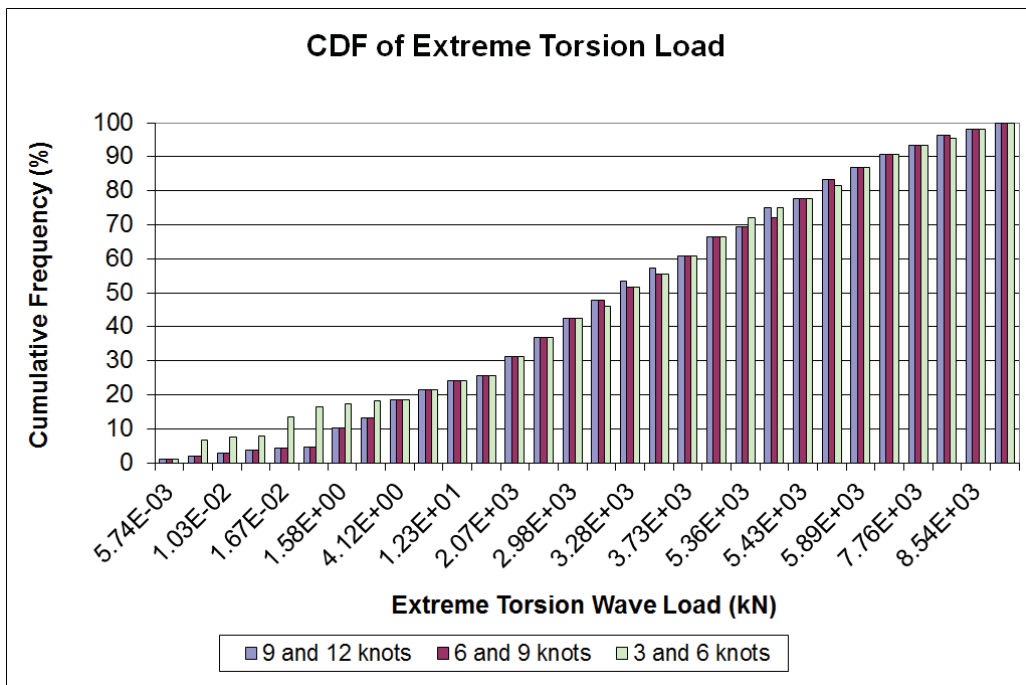

Figure 17: Cumulative Distribution Function of the Extreme Torsion on the Midship of the Intact Vessel

### 3.3 Estimates of the Ultimate Strength of the Intact Vessel

The ultimate strength of the midship section of the intact vessel is computed using UTMAT. Figure 18 show the ultimate strength interaction curve for the FE calibrated and the IACS load shortening curves. The interaction coefficients (Section 2.3.3, Equation 1) are developed for the four quadrants of the interaction curves. The quadrants are numbered counter-clockwise from 1 to 4 starting with +x, +y quadrant. The +y quadrants (1 and 2) represent hogging mode and the -y quadrants represent the sagging modes. The plots of the normalised estimates and fitted ultimate bending moment capacities are shown in Figure 19 and Figure 20 where it is seen that the interaction coefficients give very good fits to the data from UTMAT. Table 11 and Table 12 summarize the ultimate vertical and horizontal bending moment capacities and the interaction coefficients for the four quadrants.

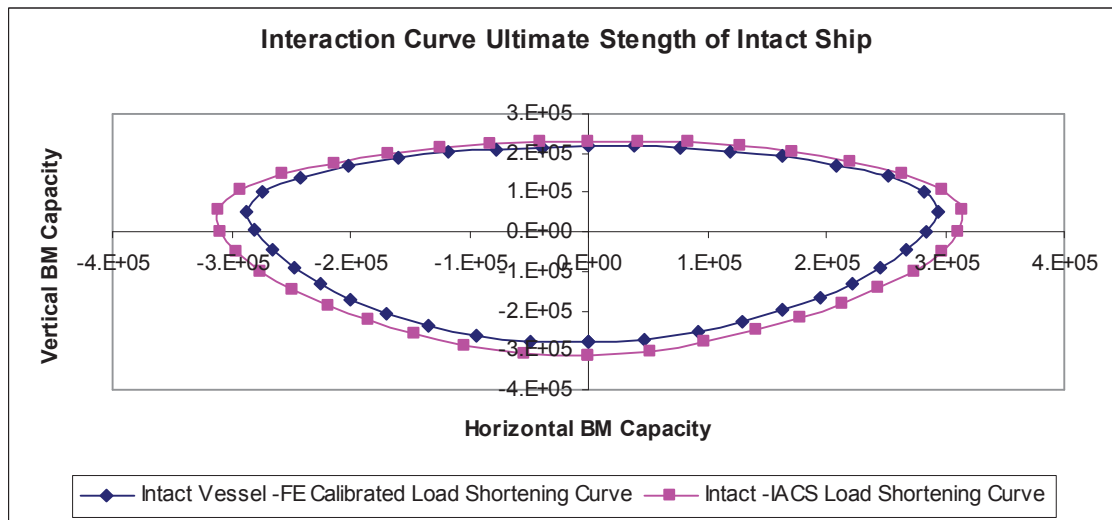
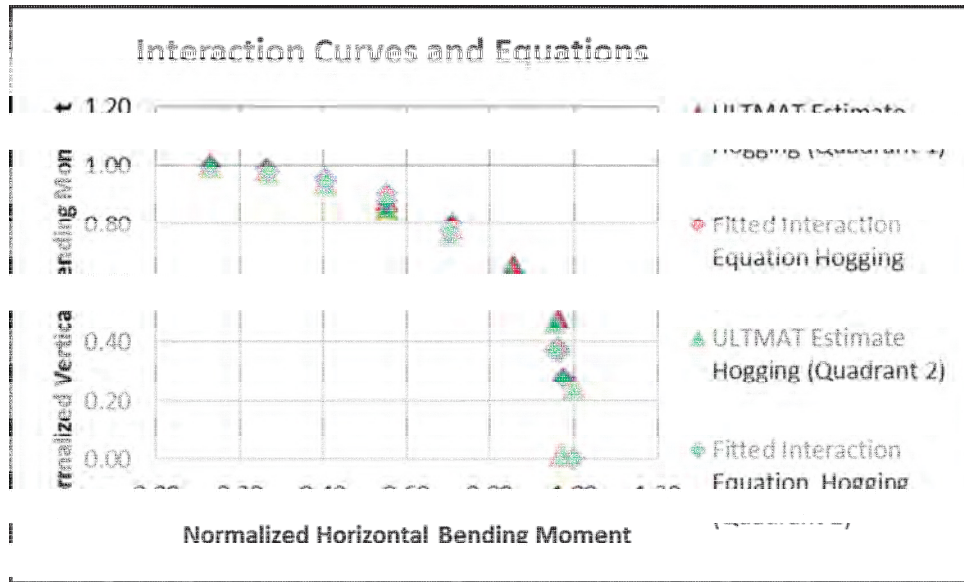
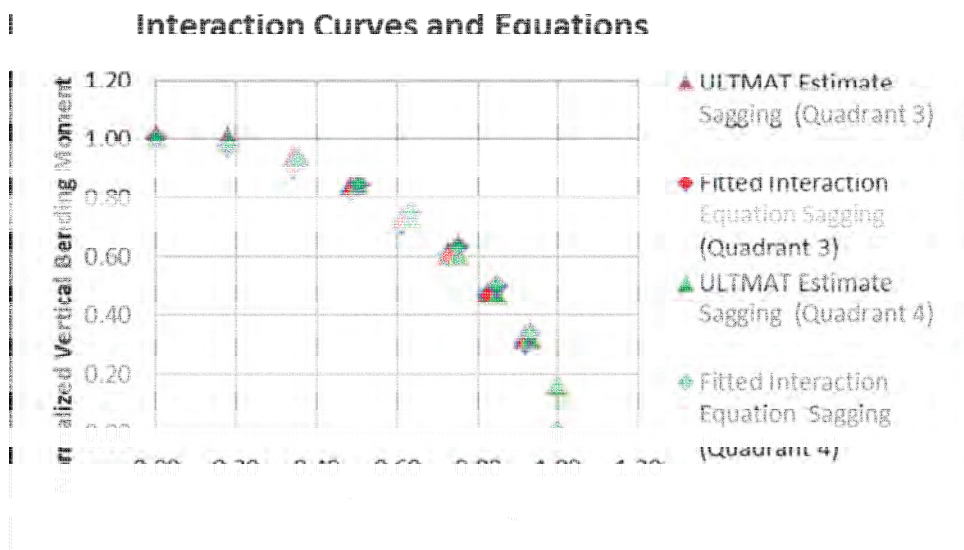

Figure 18: The Ultimate Bending Moment Capacities Interaction Curve of the Midship Section of the Intact Vessel



(a) Hogging Condition



(b) Sagging Condition

Figure 19: Normalized Ultimate Bending Moment Capacities Interaction Curve of the Midship Section of the Intact Vessel (FE Calibrated Load shortening Curve)



(a) Hogging Condition

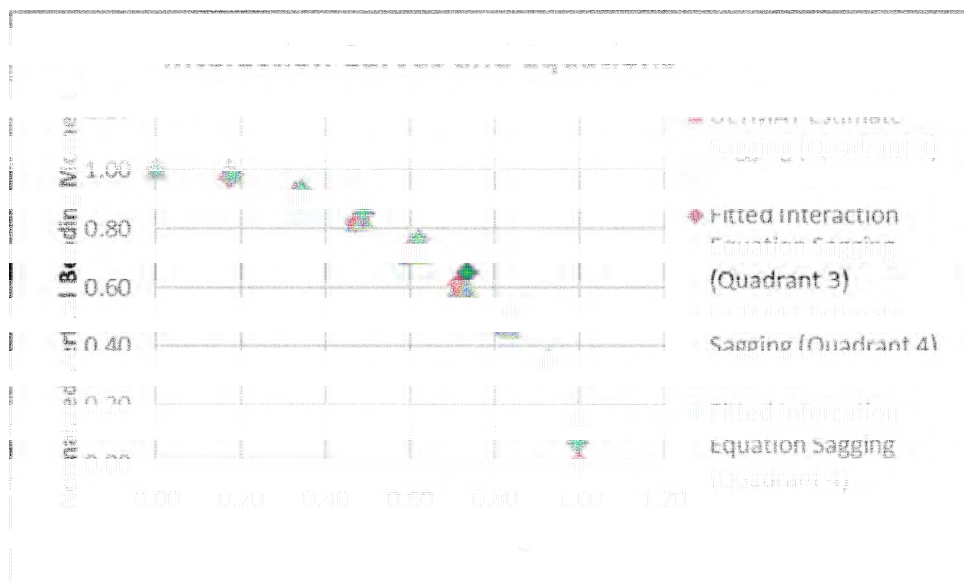

(b) Sagging Condition

Figure 20: Normalized Ultimate Bending Moment Capacities Interaction Curve of the Midship Section of the Intact Vessel (IACS Load shortening Curve)

Table 11: Summary of the Ultimate Strengths and the Interaction Coefficient of the Midship of the Intact Vessel (IACS Load Shortening Curves)

Load Case	Name	Mean Value	COV	Probability Distribution
<b>Quadrant -1:</b> IACS Load Shortening Curve	Ultimate Vertical Bending Moment Capacity (kNm)	230634.10	0.04	Weibull
	Ultimate Horizontal Bending Moment Capacity (kNm)	313797.20	0.04	Weibull
	Interaction Coefficient for Vertical Bending Moment Capacities	2.50		Fixed
	Interaction Coefficient for Horizontal Bending Moment Capacities	2.50		Fixed
<b>Quadrant -4:</b> IACS Load Shortening Curve	Ultimate Vertical Bending Moment Capacity (kNm)	-301648.60	0.04	Weibull
	Ultimate Horizontal Bending Moment Capacity (kNm)	296922.90	0.04	Weibull
	Interaction Coefficient for Vertical Bending Moment Capacities	1.70		Fixed
	Interaction Coefficient for Horizontal Bending Moment Capacities	1.70		Fixed
<b>Quadrant -3:</b> IACS Load Shortening Curve	Ultimate Vertical Bending Moment Capacity (kNm)	-312292.10	0.04	Weibull
	Ultimate Horizontal Bending Moment Capacity (kNm)	-296273.40	0.04	Weibull
	Interaction Coefficient for Vertical Bending Moment Capacities	1.90		Fixed
	Interaction Coefficient for Horizontal Bending Moment Capacities	1.90		Fixed
<b>Quadrant -2:</b> IACS Load Shortening Curve	Ultimate Vertical Bending Moment Capacity (kNm)	228450.60	0.04	Weibull
	Ultimate Horizontal Bending Moment Capacity (kNm)	-310278.00	0.04	Weibull
	Interaction Coefficient for Vertical Bending Moment Capacities	2.30		Fixed
	Interaction Coefficient for Horizontal Bending Moment Capacities	2.30		Fixed

Table 12: Summary of the Ultimate Strengths and Interaction Coefficients of the Midship of the Intact Vessel (FE Calibrated Load Shortening Curves)

Load Case	Name	Mean Value	COV	Probability Distribution
<b>Quadrant -1:</b> FE Calibrated Load Shortening Curve	Ultimate Vertical Bending Moment Capacity (kNm)	216622.80	0.04	Weibull
	Ultimate Horizontal Bending Moment Capacity (kNm)	293815.80	0.04	Weibull
	Interaction Coefficient for Vertical Bending Moment Capacities	2.50		Fixed
	Interaction Coefficient for Horizontal Bending Moment Capacities	2.50		Fixed
<b>Quadrant -4:</b> FE Calibrated Load Shortening Curve	Ultimate Vertical Bending Moment Capacity (kNm)	-272489.70	0.04	Weibull
	Ultimate Horizontal Bending Moment Capacity (kNm)	267287.20	0.04	Weibull
	Interaction Coefficient for Vertical Bending Moment Capacities	1.70		Fixed
	Interaction Coefficient for Horizontal Bending Moment Capacities	1.70		Fixed
<b>Quadrant -3:</b> FE Calibrated Load Shortening Curve	Ultimate Vertical Bending Moment Capacity (kNm)	-280300.30	0.04	Weibull
	Ultimate Horizontal Bending Moment Capacity (kNm)	-265991.50	0.04	Weibull
	Interaction Coefficient for Vertical Bending Moment Capacities	1.90		Fixed
	Interaction Coefficient for Horizontal Bending Moment Capacities	1.90		Fixed
<b>Quadrant -2:</b> FE Calibrated Load Shortening Curve	Ultimate Vertical Bending Moment Capacity (kNm)	217167.60	0.04	Weibull
	Ultimate Horizontal Bending Moment Capacity (kNm)	-287192.80	0.04	Weibull
	Interaction Coefficient for Vertical Bending Moment Capacities	2.30		Fixed
	Interaction Coefficient for Horizontal Bending Moment Capacities	2.30		Fixed

### 3.4 Estimates of the Reliability of the Intact Vessel

COMPASS is used to perform the reliability analyses of the intact vessel. Both the first order reliability method, FORM, and the Monte Carlo Simulation method, MCS, are employed to estimate the probabilities of failure of the vessel and the importance factors of the various random variables. The analyses are performed using the linear and the interaction equation limit state functions. The probabilistic characteristics of the random variables is summarised in Table 13.

*Table 13: Summary of the Probabilistic Characteristics of the Random Variables Used for the Reliability Assessment of the Intact Vessel.*

Name	Mean Value	COV	Probability Distribution
Ultimate Vertical Bending Moment capacity (kNm), $M_{VU}$	Depends on Quadrant Table 11 Table 12	0.04	Weibull
Modelling Uncertainty Factor for Ultimate Vertical Bending Moment Capacities, $x_{VU}$	1	0.10	Normal
Vertical Wave Bending Moment (kNm), $M_{VW}$	Depends on Speed Case Table 10	Depends on Speed Case Table 10	Gumbel
Modelling Uncertainty Factor for Vertical Wave Bending Moment, $x_{VW}$	1	0.10	Normal
Vertical Still Water Bending Moment (kNm), $M_{VSW}$	33534.22	0.10	Normal
Modelling Uncertainty Factor for Vertical Still Water Bending Moment $x_{VSW}$	1	0.10	Normal
Vertical Load Combination Factor, $\Psi_V$	1		Fixed
Ultimate Horizontal Bending Moment Capacity (kNm), $M_{HU}$	Depends on Quadrant Table 11 Table 12	Intact 0.04	Weibull
Modelling Uncertainty Factor for Ultimate Horizontal Bending Moment Capacities, $x_{HU}$	1	0.10	Normal
Horizontal Wave Bending Moment (kNm), $M_{HW}$	Depends on Speed Case Table 10	Depends on Speed Case Table 10	Gumbel

Name	Mean Value	COV	Probability Distribution
Modelling Uncertainty Factor for Horizontal Wave Bending Moment, $x_{HW}$	1	0.10	Normal
Horizontal Still Water Bending Moment (kNm), $M_{HSW}$	1643.32	0.10	Normal
Modelling Uncertainty Factor Horizontal Still Water Bending Moment, $x_{HSW}$	1	0.10	Normal
Horizontal Load Combination Factor, $\Psi_H$	1		Fixed
Vertical interaction Coefficient $m$	Depends on Quadrant Table 11 Table 12		Fixed
Horizontal interaction Coefficient $n$	Depends on Quadrant Table 11 Table 12		Fixed

Table 14 and Table 15 summarise the results of the structural integrity of the intact vessel. The following conclusions are drawn from the tables:

- The interaction equation model, which is a better model for representing the capacities and loads on the intact vessel, gives estimates of probabilities of failures that are always smaller than the estimates from the linear model. This is because the linear model uses only the vertical components of bending loads on the ship, which are large, and the vertical component of ship capacity, which is small. The modulating or interacting effects of the horizontal components of the bending loads, which are small, and the ship capacity, which is large, are neglected in the linear model. Therefore any result of structural integrity from the linear model will be conservative, thus underscoring the need to use the better quality interaction model when performing deterministic and reliability analysis of ships. The practical implication is that the linear model will lead to overdesign of the ship.
- For both the linear and the interaction limit state functions, and the FE calibrated and the IACS load shortening curves, the second quadrants of the structural strength, which represents hogging mode, give the highest estimates of failure probabilities and is therefore the quadrant that governs the failure of the intact vessel.
- The higher the vessel speed the higher the probability of failure and vice versa.
- FORM and Monte Carlo Simulation estimates of reliabilities are very close to each other. Since FORM and MCS give similar results then FORM can be used to estimate the reliability of structures without undermining the accuracy of the results for cases where

there may be a need to use very costly models such as the finite element method to determine structural capacities.

- Estimates of the failure probabilities computed using the IACS load shortening curves are always lower than those based on the FE calibrated curves implying that the FE calibrated curves give more conservative results. This result is consistent with the estimates of the deterministic structural strength shown in Figure 18.

*Table 14: Summary of the Probabilities of Failures of the Midship Section of the Intact Vessel Using the IACS Load Shortening Curves*

Case No	Speed (knots)	Strength Quadrant	Probability of Failure (Linear Model)		Probability of Failure (Interaction Equation Model)	
			FORM	MCS	FORM	MCS
Case 1	3 and 6	1	3.19E-04	3.05E-04	4.47E-05	3.75E-05
		4	2.55E-06	2.54E-06	5.10E-08	5.09E-08
		3	1.23E-06	1.26E-06	1.33E-08	1.35E-08
		2	3.69E-04	3.55E-04	5.57E-05	4.78E-05
Case 2	6 and 9	1	8.08E-04	7.75E-04	1.82E-04	1.48E-04
		4	9.58E-06	9.33E-06	4.89E-07	2.21E-07
		3	4.87E-06	4.58E-06	1.51E-07	1.72E-07
		2	9.22E-04	8.86E-04	2.21E-04	1.78E-04
Case 3	9 and 12	1	1.20E-03	1.15E-03	3.29E-04	2.68E-04
		4	1.73E-05	1.76E-05	7.27E-07	6.38E-07
		3	9.02E-06	8.57E-06	4.35E-07	1.63E-07
		2	1.36E-03	1.30E-03	3.94E-04	3.23E-03

*Table 15: Summary of the Probabilities of Failures of the Midship Section of the Intact Vessel Using the FE Calibrated Load Shortening Curves*

Case No	Speed (knots)	Strength Quadrant	Probability of Failure (Linear Model)		Probability of Failure (Interaction Equation Model)	
			FORM	MCS	FORM	MCS
Case 1	3 and 6	1	8.79E-04	8.50E-04	2.02E-04	1.66E-04
		4	2.19E-05	2.27E-05	1.07E-06	9.30E-07
		3	1.30E-05	1.30E-05	4.09E-07	2.84E-07
		2	8.49E-04	8.18E-04	1.95E-04	1.61E-04
Case 2	6 and 9	1	1.87E-03	1.78E-03	5.80E-04	4.83E-04
		4	6.05E-05	6.44E-05	5.09E-06	4.50E-06
		3	4.87E-06	4.58E-06	1.51E-07	1.72E-07
		2	1.81E-03	1.72E-03	5.56E-04	4.70E-04
Case 3	9 and 12	1	2.66E-03	2.53E-03	9.66E-04	8.07E-04
		4	1.01E-04	1.04E-04	1.16E-05	1.00E-05
		3	6.32E-05	6.61E-05	5.18E-06	4.35E-06
		2	2.58E-03	2.46E-03	9.30E-04	7.84E-04

The importance factors of the random variables involved in the reliability analyses are computed for all the 24 cases listed in Table 14 and Table 15. Figure 21 to Figure 26 show the importance factors for the second strength quadrant that governs the failure of the intact vessel. The importance factors express the relative importance of the different sources of uncertainty associated with the basic random variables that define a problem. The other important factors, which have profiles similar to Figure 21 to Figure 26, are summarised in Annex A. The following are observed from Figure 21 to Figure 26.

- When using the interaction equation model, uncertainties in three parameters, the vertical wave bending moment, the modelling uncertainty of the vertical wave bending moment and the ultimate vertical bending moment govern the failure of the intact vessel. Of the three, the vertical wave bending moment and its uncertainty is the main parameter that drives the failure of the intact vessel. This is followed by the uncertainties in the model used to estimate the vertical wave bending moment.
- When using the linear equation model, uncertainties in four parameters, the vertical wave bending moment, the modelling uncertainty of the ultimate vertical bending moment, the modelling uncertainty of the vertical wave bending moment and the ultimate vertical bending moment govern the failure of the intact vessel. Of the four, the vertical wave bending moment is the main parameter that governs the failure of the intact vessel. This is very closely followed by the uncertainties in the model used to estimate the ultimate vertical bending moment. The high importance attributed to the model used to estimate the ultimate vertical bending moment underscores the need to ensure that an accurate structural model that reflects the failure under consideration is used for the assessment.
- In general the higher the vessel speed, as represented by the higher values and uncertainties in the vertical bending moment, the higher the importance factor of the vertical bending moment. This demonstrates the importance of using a model that accurately estimates the RAOs on the vessel for the speed under consideration.

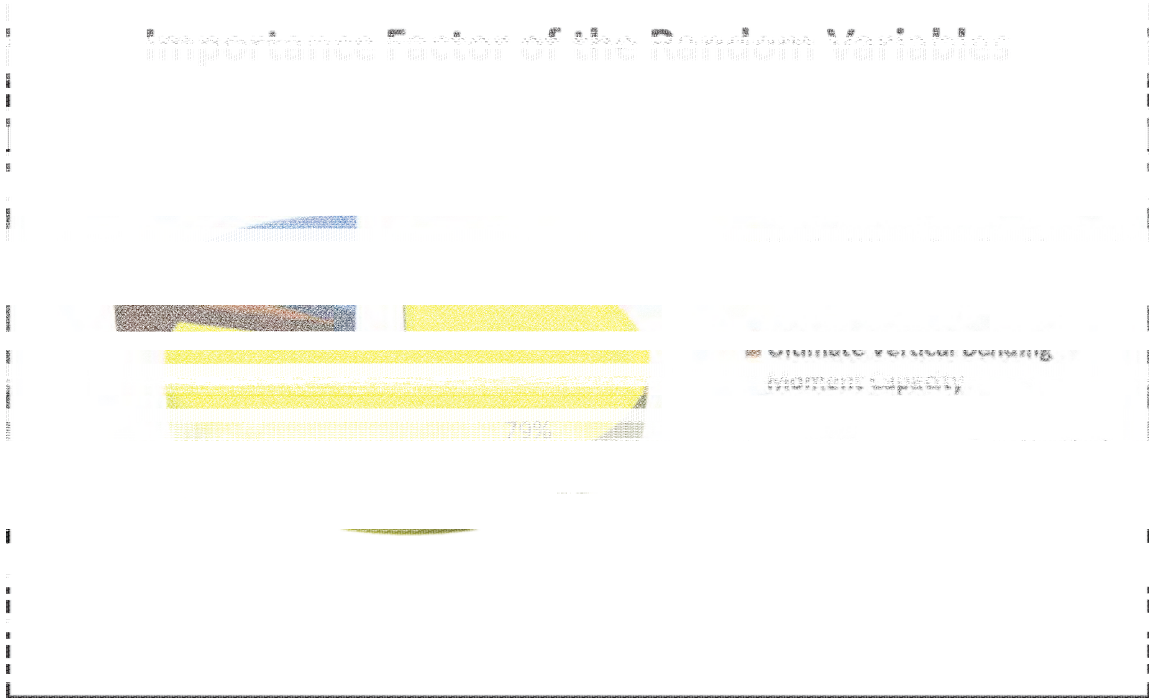

(a)

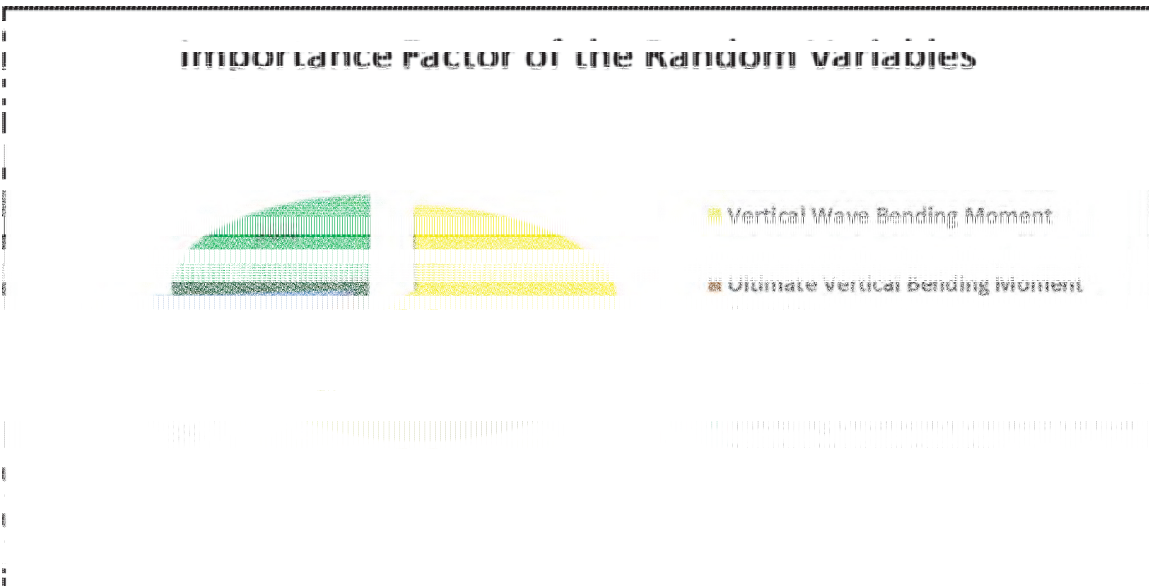

(b)

Figure 21: The Importance Factors of the Random Variables in Case 1 Intact Vessel; 3 and 6 knots, IACS Interaction Curve (a) Interaction Equation Model (b) Linear Model

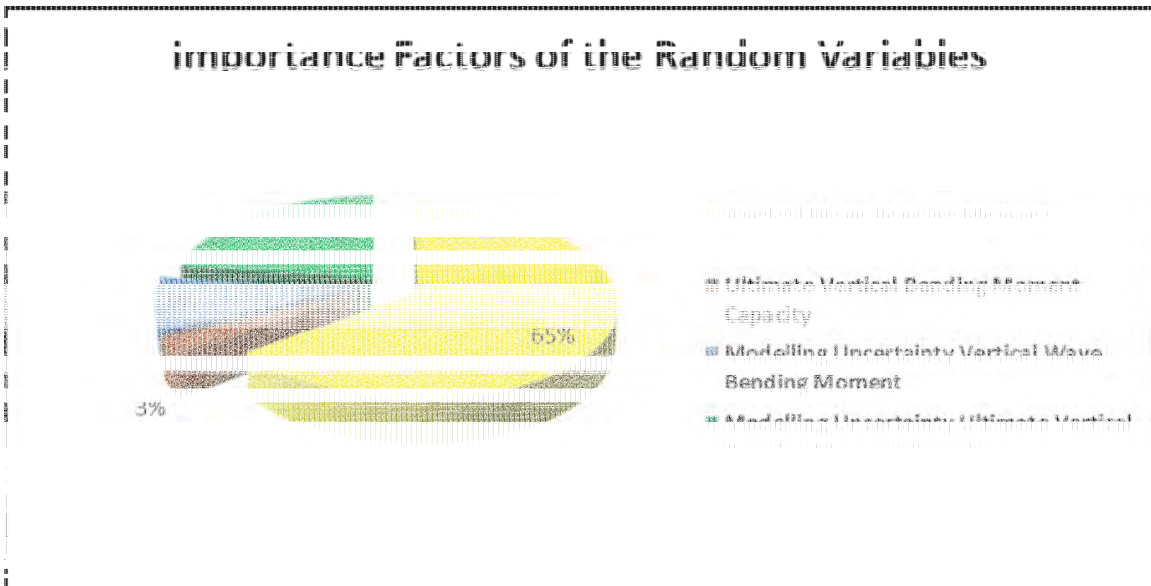
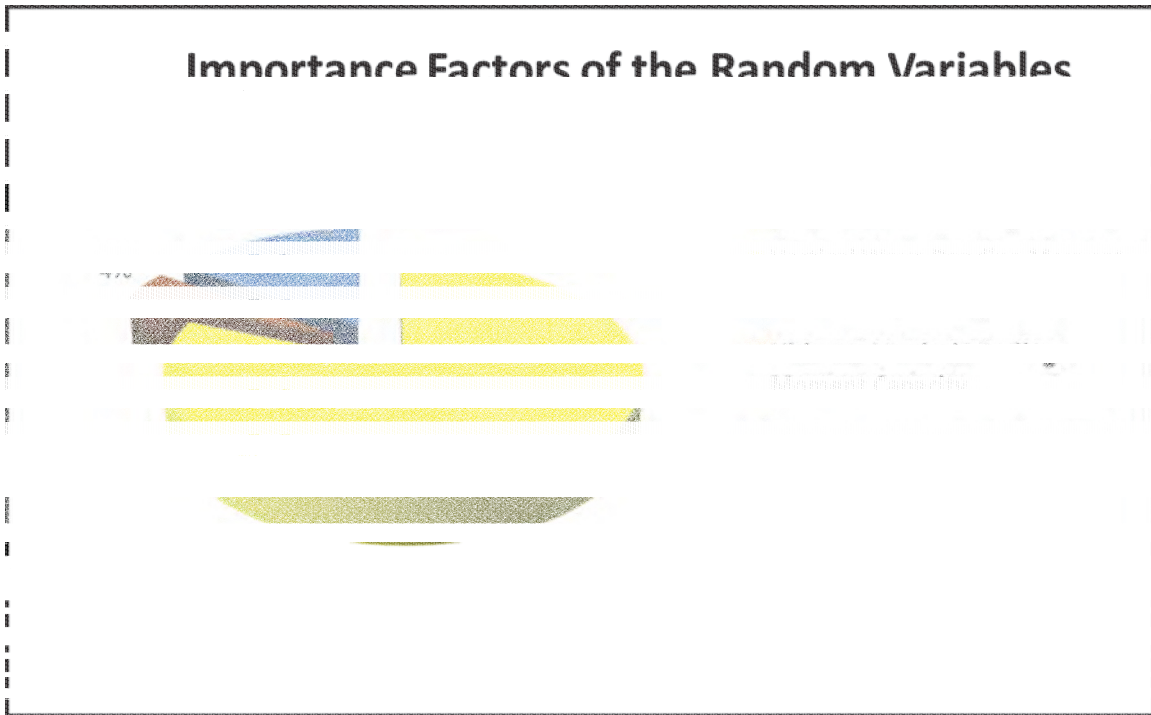
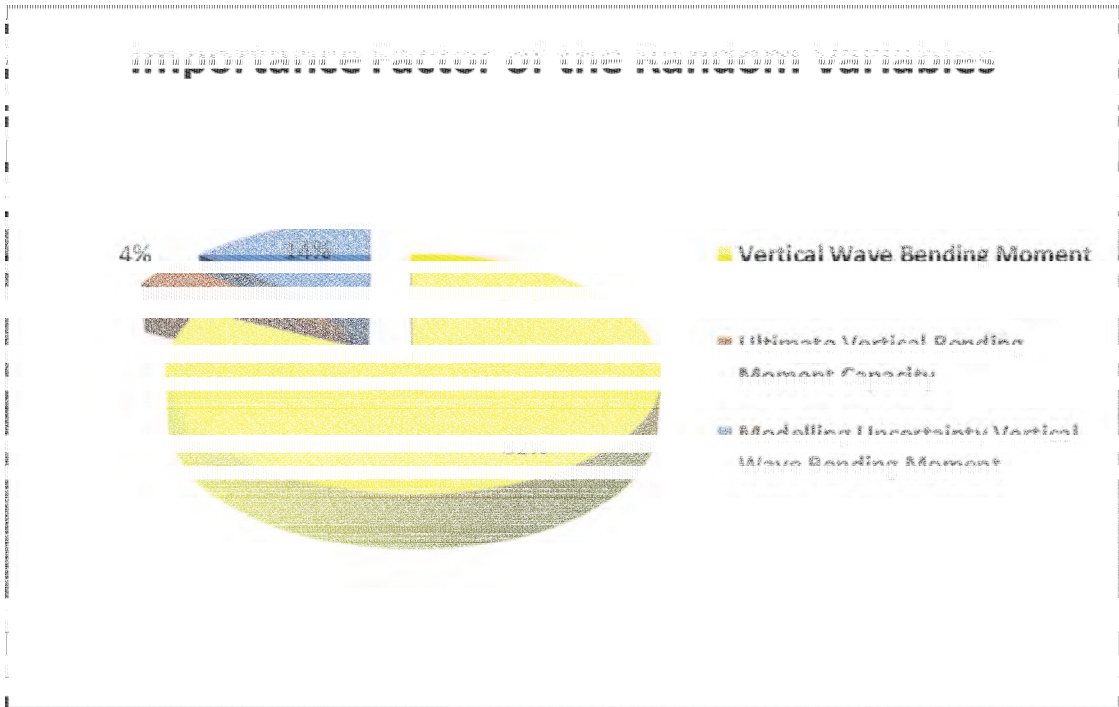
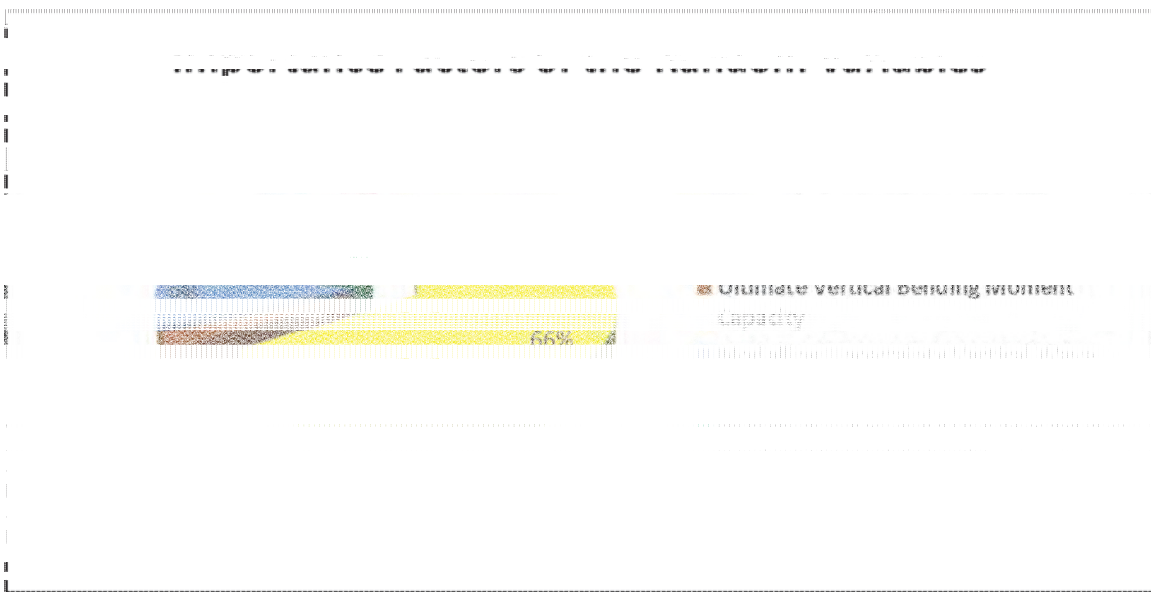

Figure 22: The Importance Factors of the Random Variables Case 2 Intact Vessel; 6 and 9 knots, IACS Interaction Curve (a) Interaction Equation Model (b) Linear Model



(a)



(b)

Figure 23: The Importance Factors of the Random Variables Case 3 Intact Vessel; 9 and 12 knots, IACS Interaction Curve (a) Interaction Equation Model (b) Linear Model

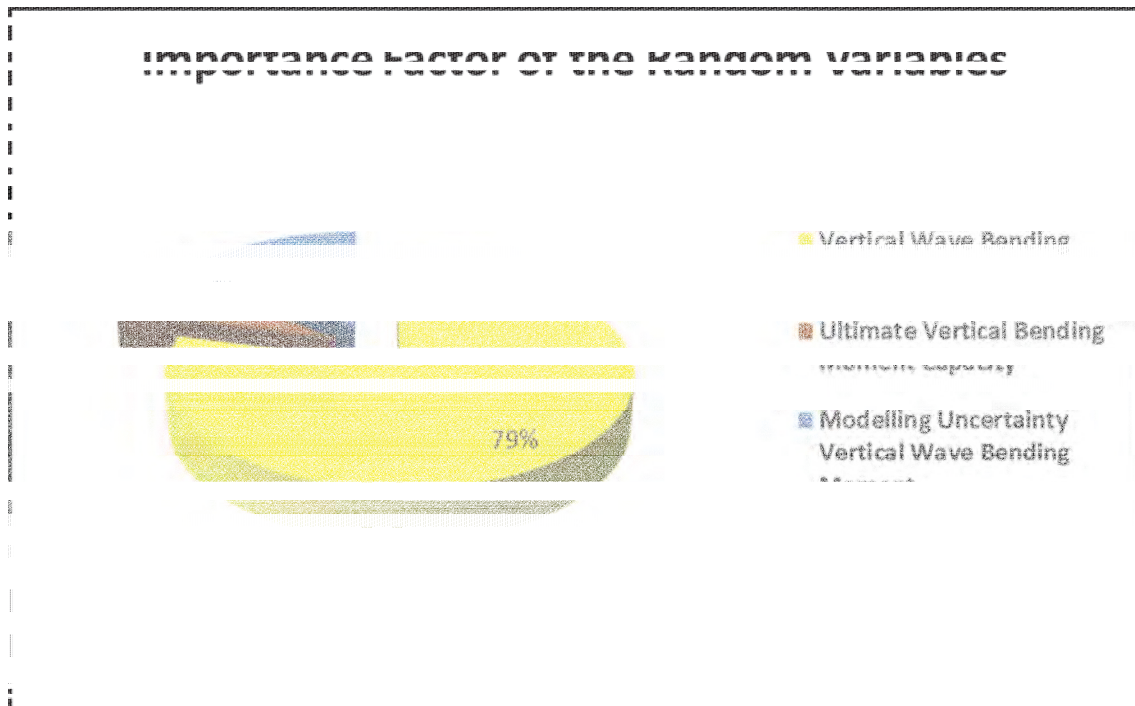

(a)

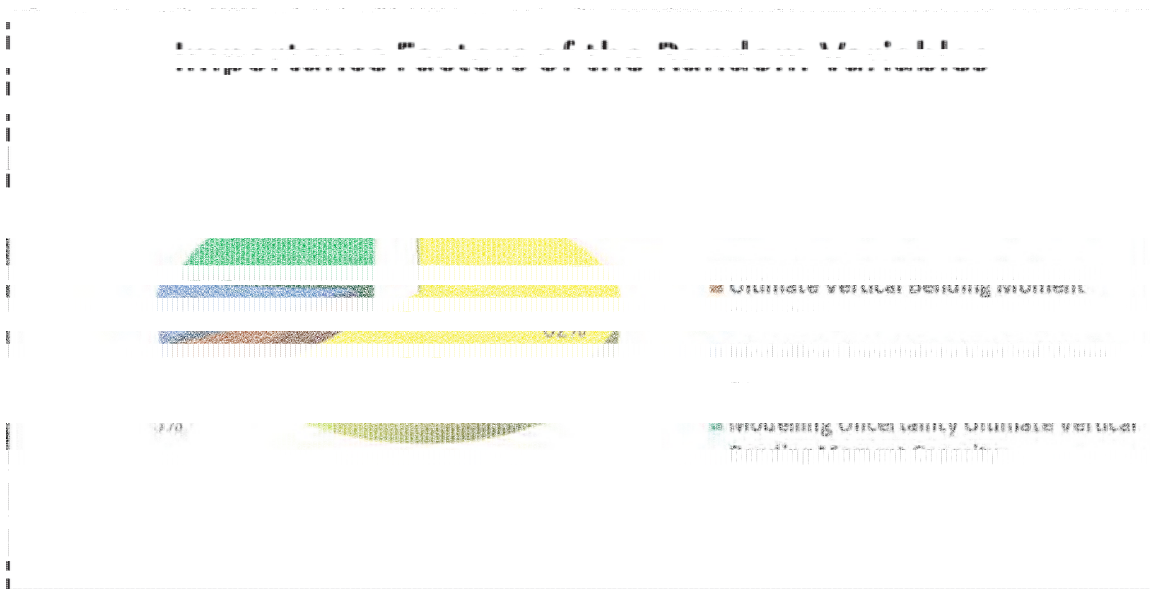

(b)

Figure 24: The Importance Factors of the Random Variables Case 1 Intact Vessel; 3 and 6 knots, FE Calibrated Interaction Curve (a) Interaction Equation Model (b) Linear Model

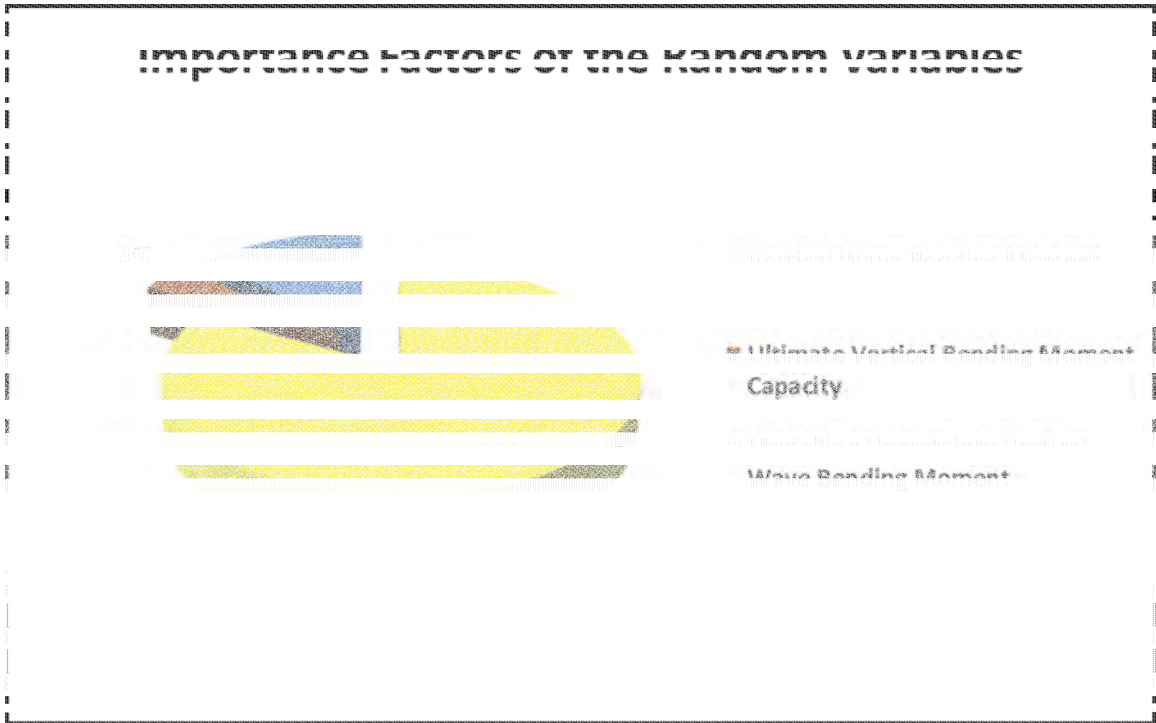

(a)

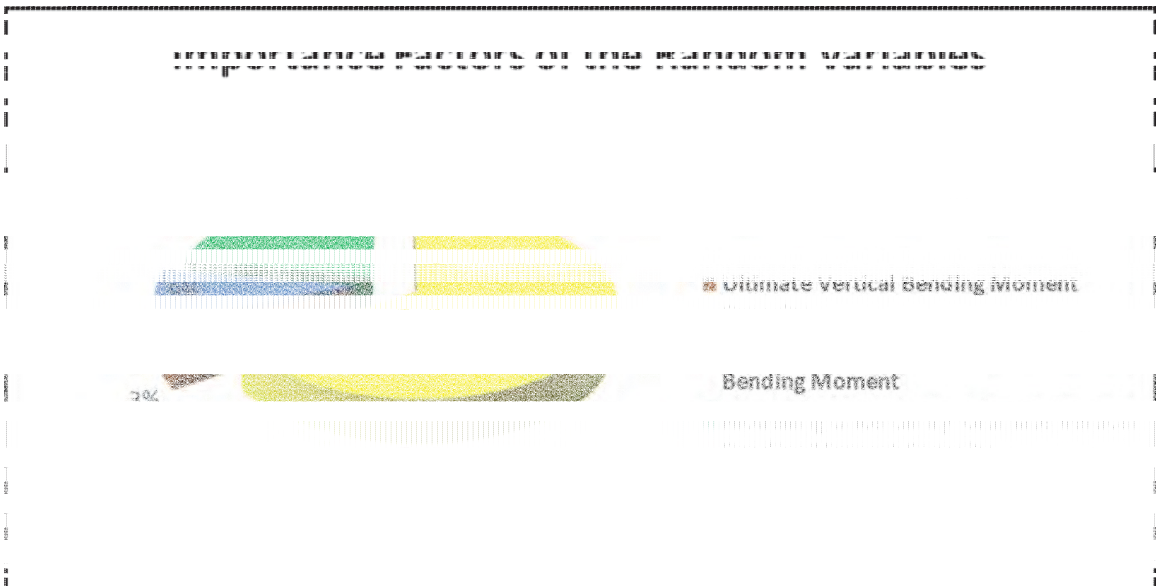

(b)

Figure 25: The Importance Factors of the Random Variables Case 2 Intact Vessel; 6 and 9 knots, FE Calibrated Interaction Curve (a) Interaction Equation Model (b) Linear Model

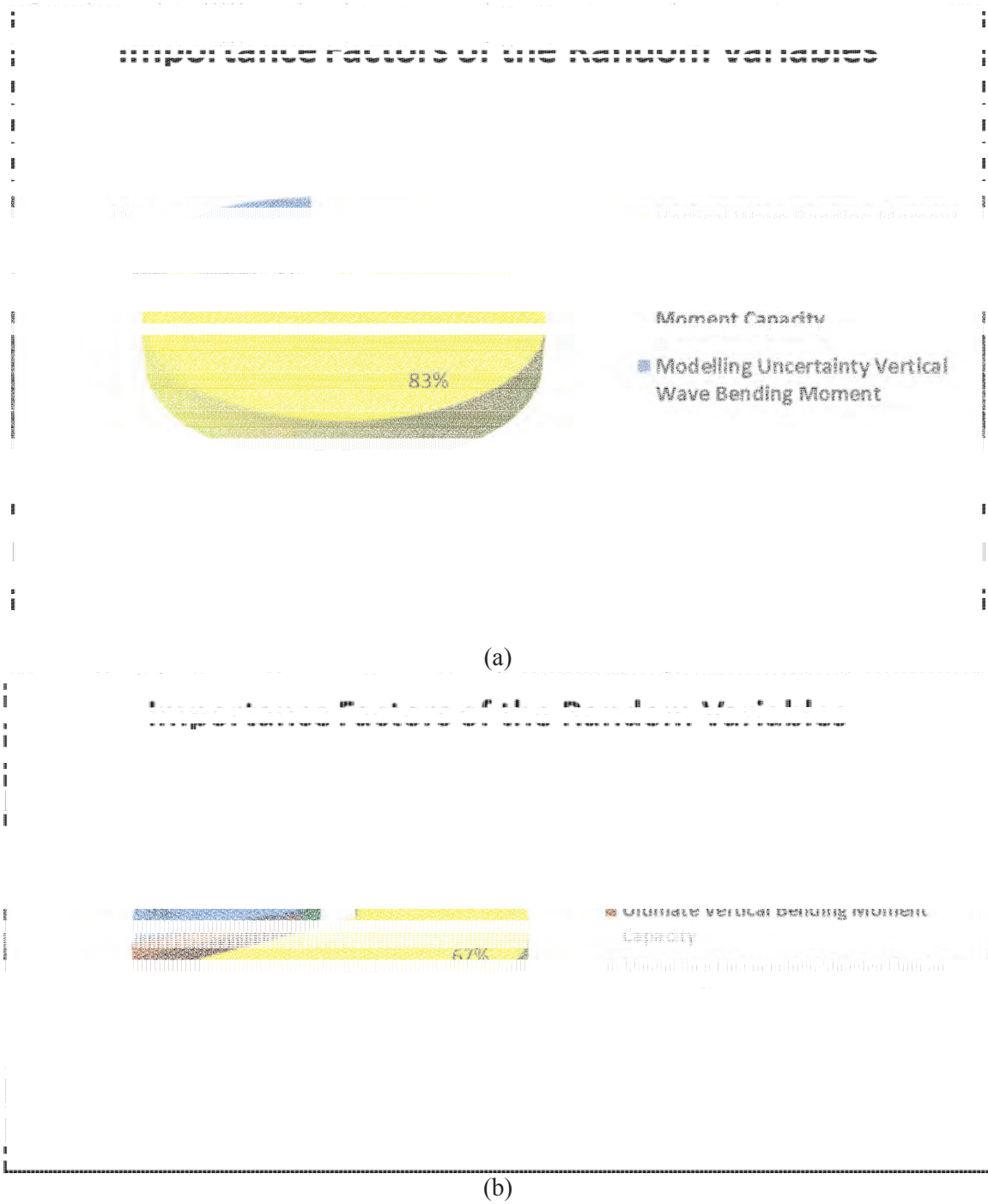

Figure 26: The Importance Factors of the Random Variables Case 3 Intact Vessel; 9 and 12 knots, FE Calibrated Interaction Curve (a) Interaction Equation Model (b) Linear Model

## 4 Reliability Assessment of the Damaged Ship

---

### 4.1 Introduction

The structural integrity of the damaged ship is performed within a reliability framework. The steps involved in the assessment are:

- Estimation and calibration of the loads on the damaged vessel, that is, determining the mean values, standard deviations and probability distributions of the loads;
- Estimation and calibration of the capacities of the damaged vessel, that is, determining the mean values, standard deviations and probability distributions of the capacities of the damaged ship; and
- Estimation of the reliabilities of the damaged vessel, that is, computing the probabilities of failures and the probabilistic sensitivities of the various random variables.

The reliability assessment is carried out on the midship section of the vessel.

### 4.2 Damage Definition

SIMCOL and COMPASS were used to estimate and calibrate the damage to the ship. Table 16 summarizes the statistics of the damage on the midship section of the vessel.

*Table 16: Statistics of the Damage on the Midship Section*

Location	Parameter	Mean Value	Standard Deviation
Midship	Damaged Length (m)	4.6	4.0
	Maximum Penetration (m)	1.6	1.5

The damage affects both the structural strengths and the loads on the vessel. The following assumptions were made concerning the influence of the damage on the structural loads and strength:

- The size and extent of damage is limited and within the submerged portion of the vessel. Although the damaged vessel can experience flooding, it is assumed that the draft and trim of the damaged vessel are very similar to that of the intact vessel and that the hydrodynamics characteristics of the damaged vessel, namely, the response amplitude operators, are also identical to that of the intact vessel. This assumption is very realistic in cases where there is limited flooding and the damage to the compartment is small and within the submerged portion of the vessel. In the more realistic case where a large compartment is damaged, resulting in the sea water occupying a fraction of the space of the damaged compartment, the floating state in the damaged vessel, trim, draft and heel will be different from the intact vessel and have to be determined. The current version of WAVELOAD does not have the function that can be used to determine the new floating

state. It is planned that this capability will be added before a future work on the damaged ship.

- It is important to note that even though the RAOs of the damaged and the intact vessel used in the analysis are the same, their extreme loads are different. The difference arises from the duration of their operations. Whereas the intact vessel is expected to operate the entire lifetime of the vessel, the damaged vessel can only operate within a limited transit timeframe to safety where it can be repaired. The extreme load on the damaged vessel is computed using a short term time frame of not more than 3 days, while the extreme load on the intact vessel is based on the life of the vessel assumed to be 25 years in the current analysis. Strictly speaking the extreme load on the intact vessel should be based on the lifetime operational profile of the vessel, but this is not the case in the current study because a huge number of hydrodynamic analyses will have to be executed. Therefore, the extreme load used for the intact vessel in the previous chapter is not "very accurate" because the operational profile used does not represent the real lifetime operational profile of the vessel.
- Although the damage size in Table 16 is given as damage length and penetration, the UTMAT analyses that are performed and used to calibrate the structural strengths of the damaged vessel is based on spherical damaged sizes of 2 m, 3 m, 4 m, 5 m, and 6 m diameters with 4 m is taken as an average value.

### 4.3 Estimates of the Loads On the Damaged Ship

#### 4.3.1 Operational Profile

Table 17 summarises the operational profile used to estimate the wave load on the damaged vessel. The operational profile is divided into three vessel speed cases to allow for the assessment of the impact of the speed on vessel's the structural integrity.

*Table 17: The Operational Profile of the Damaged Vessel*

	<b>Vessel Speed (knots)</b>	<b>% Time Spent</b>
<b>Case 1</b>	3	50
	6	50
<b>Case 2</b>	6	50
	9	50
<b>Case 3</b>	9	50
	12	50
<b>Headings (Degrees)</b>	<b>% Time Spent</b>	
0	5	
45	30	
90	20	
135	30	
180	15	
<b>Location: North Atlantic</b>		

<b>Spectrum: Bretscheinder (<math>H_s</math>, <math>T_z</math>)</b>		
<b><math>H_s</math>(m)</b>	<b><math>T_z</math>(sec)</b>	<b>% Time Spent in Each State</b>
6.5	7.5	20
4.5	7.5	40
2.5	7.5	40
Vessel Loading Condition - 3,474,900 kg		

### 4.3.2 Still Water Bending Moment

The still water bending moment used for the damaged ship is the same as the one for the intact vessel. Plots of the still water loads were shown in Figure 4 to Figure 8. The probabilistic characteristics of the still water bending moments are summarised in Table 18.

*Table 18: Summary of the Still Water Loads on the Damaged Ship*

<b>Name</b>	<b>Mean Value</b>	<b>COV</b>	<b>Probability Distribution</b>
Vertical Still Water Bending Moment (kNm)	33534.22	0.10	Normal
Horizontal Still Water Bending Moment (kNm)	1643.32	0.10	Normal

### 4.3.3 Wave-Induced Bending Moment

#### 4.3.3.1 RAO of the Damaged Section

The Response amplitude operators, RAOs, for the midship section of the intact and the damaged are the same and were computed using WAVELOAD. Figure 9 to Figure 13 showed plots of the RAOs for the midship section. Similar RAOs were computed for the other sections of the vessel. Figure 27 and Figure 28 show the effect of the vessel speed on the amplitude of the vertical and horizontal bending moment RAO where it is seen that the higher the vehicle speed, the bigger the amplitudes of the RAOs.

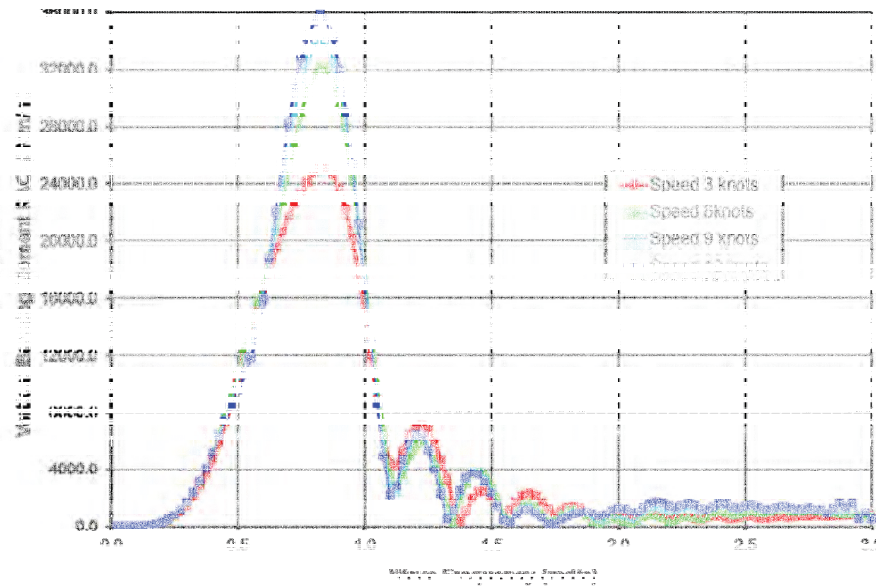
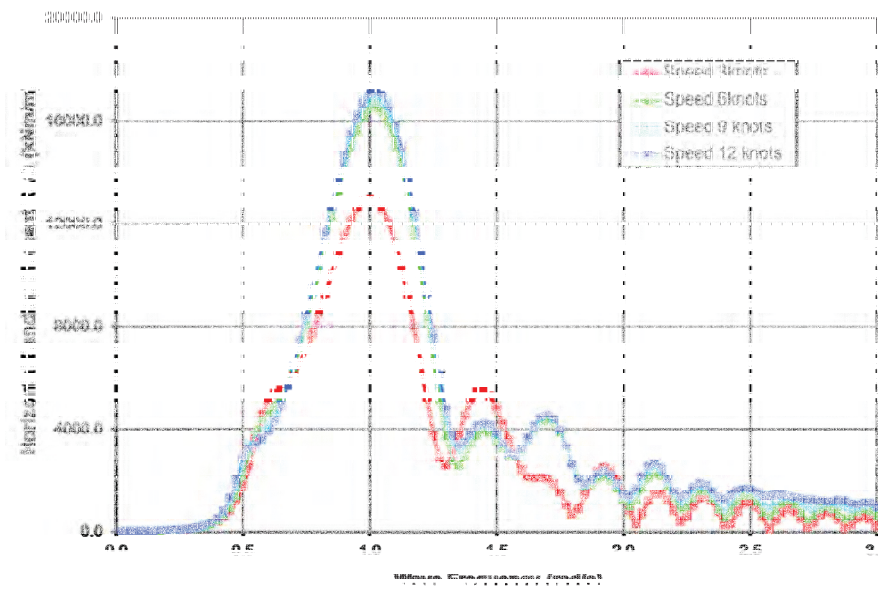

Figure 27: The Effect of the Vessels Speed on the RAOs of the Vertical Bending Moment



Max

Figure 28: The Effect of Speed on the RAOs of the Horizontal Bending Moment

#### 4.3.3.2 Extreme Value of Wave Loads on the Damaged Ship

The extreme values of the wave loads on the damaged ship were computed using the operational profile defined in Table 17, the RAOs presented in Section 3.3 and the method described in Akpan et al, 2012. Figure 29 to Figure 32 show the cumulative distribution functions for the extreme vertical and horizontal bending moments for the speed cases defined in Table 17: 3 and 6

knots, 6 and 9 knots, and 9 and 12 knots. The statistics of these extreme loads, computed using COMPASS, are summarised in Table 19.

Table 19: Summary of the Extreme Wave Loads on the Mid-Section of the Damaged Ship

Load Case	Name	Mean Value	COV	Probability Distribution
3 and 6 knots	Vertical Wave Bending Moment (kNm)	48968.26	0.59	Gumbel
	Horizontal Wave Bending Moment (kNm)	17569.30	0.81	Gumbel
6 and 9 knots	Vertical Wave Bending Moment (kNm)	51870.00	0.61	Gumbel
	Horizontal Wave Bending Moment (kNm)	18017.00	0.83	Gumbel
9 and 12 knots	Vertical Wave Bending Moment (kNm)	52599.00	0.63	Gumbel
	Horizontal Wave Bending Moment (kNm)	17535.00	0.85	Gumbel

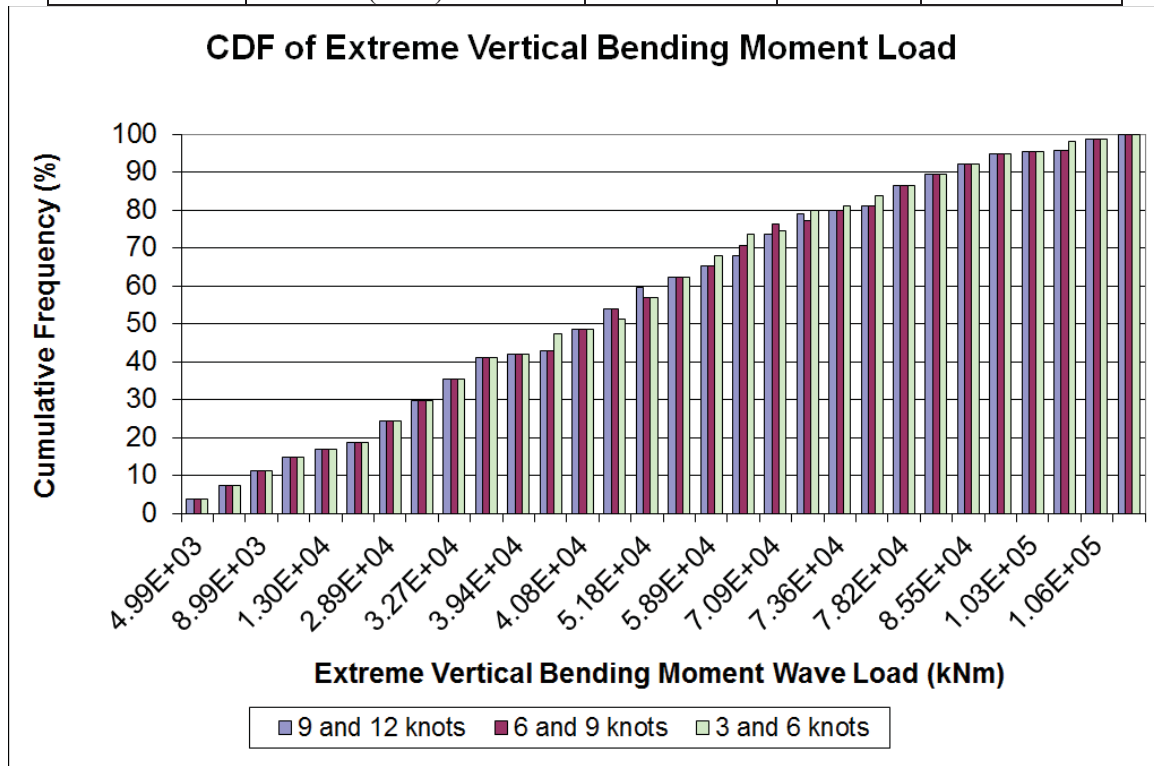

Figure 29: Cumulative Distribution Function of the Extreme Vertical Bending Moment on the Midship of the Damaged Vessel

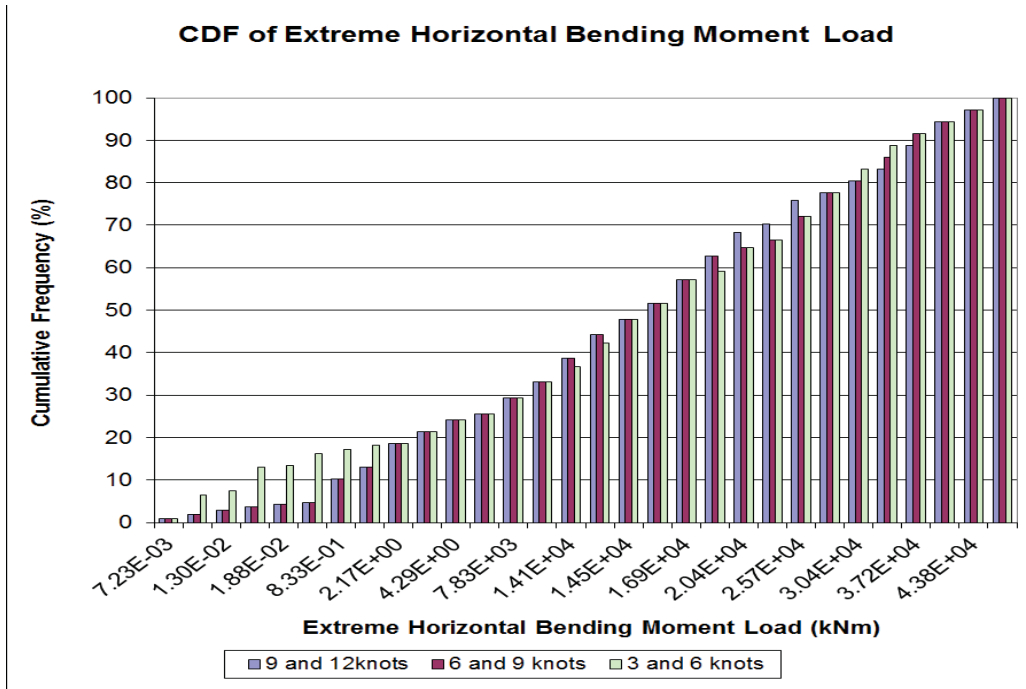

Figure 30: Cumulative Distribution Function of the Extreme Horizontal Bending Moment on the Midship of the Damaged Vessel

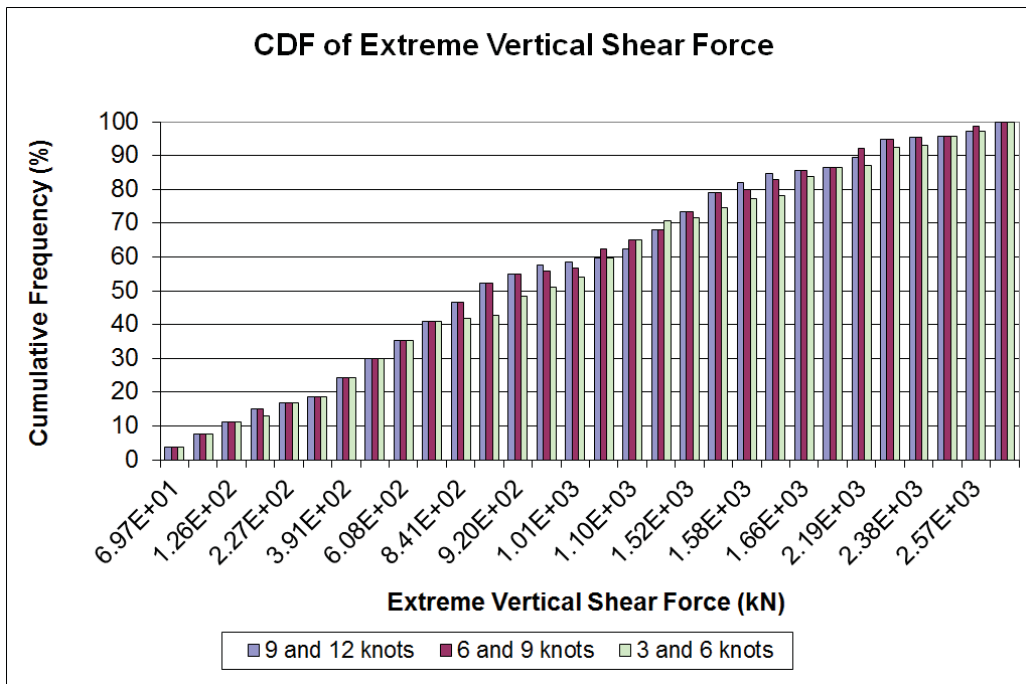

Figure 31: Cumulative Distribution Function of the Extreme Vertical Shear Force on the Midship of the Damaged Vessel

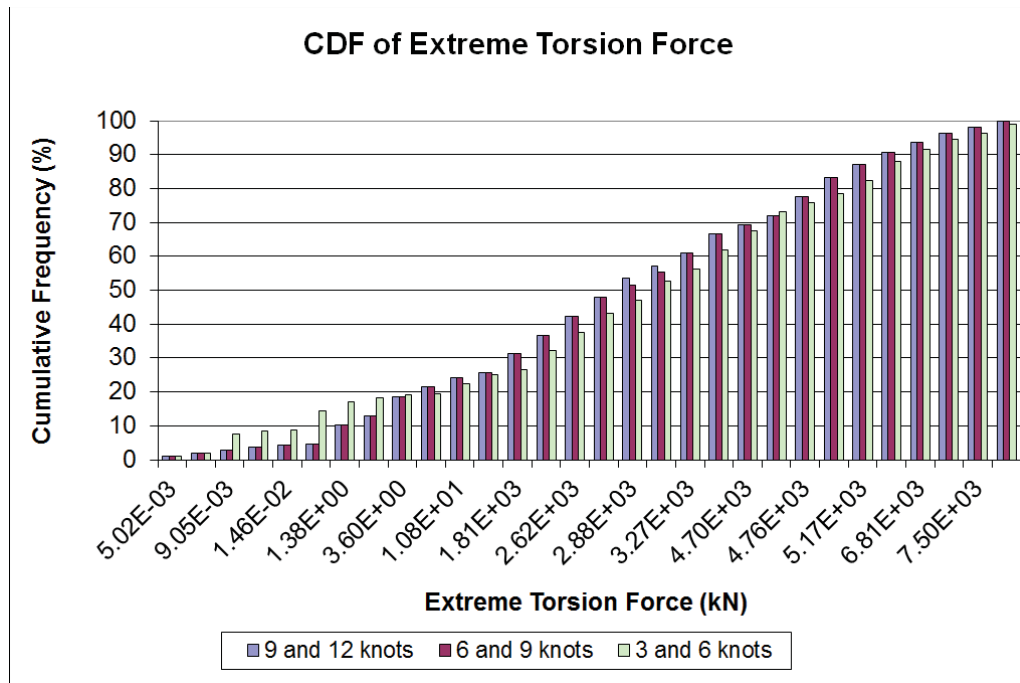
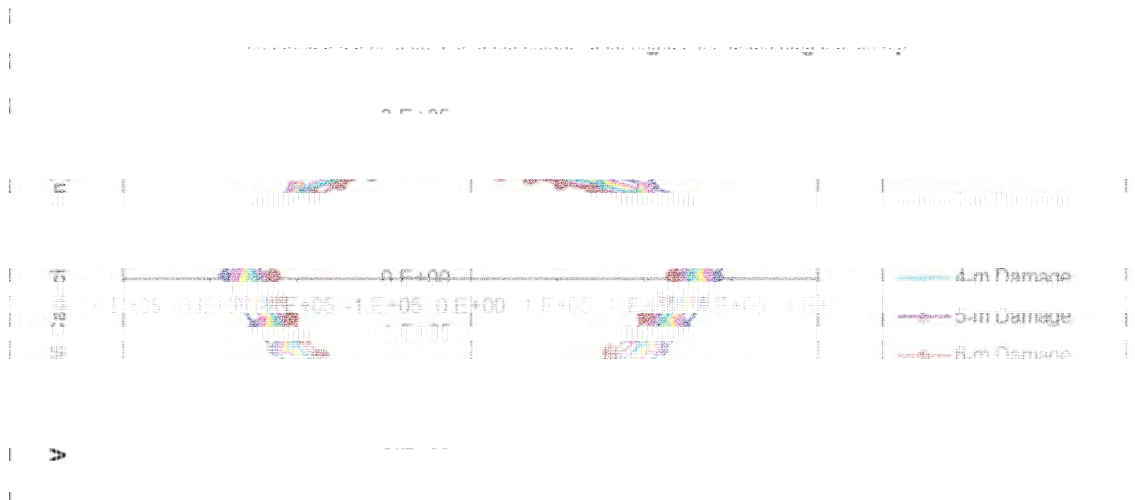

Figure 32: Cumulative Distribution Function of the Extreme Torsion on the Midship of the Damaged Vessel

#### 4.4 Estimates of the Ultimate Strength Capacities of the Damaged Ship

Although the damage size in Table 16 was given as damage length and penetration, the UTMAT analyses that are performed and used to calibrate the structural strengths of the damaged vessel was based on spherical damaged sizes of 2 m, 3 m, 4 m, 5 m, and 6 m diameters, and 4 m was taken as an average value. The ultimate strength of the mid-section of the damaged vessel was computed using UTMAT. Figure 33 shows the ultimate strength interaction curves for the damage sphere sizes of 2 m, 3 m, 4 m, 5 m, and 6 m for the FE calibrated and the IACS load shortening curves. Figure 34 compares the interaction curves between the intact vessel and the damaged vessel and Figure 35 compares the average damaged interaction curves based on FE calibrated and IACS model. The interaction coefficients (Section 2.33, Equation 1) were developed for the four quadrants of the interaction curves. The quadrants are numbered counter-clockwise from 1 to 4 starting with +x, +y quadrant. The +y quadrants (1 and 2) represent hogging mode and the -y quadrants represent the sagging modes. The plots of the normalised estimates and fitted ultimate strengths are shown in Figure 36 and Figure 37. In general it is noted that the horizontal capacity of the vessel is more sensitive to damage than the vertical capacity and the IACS model is more conservative than the FE calibrated model.



(a)

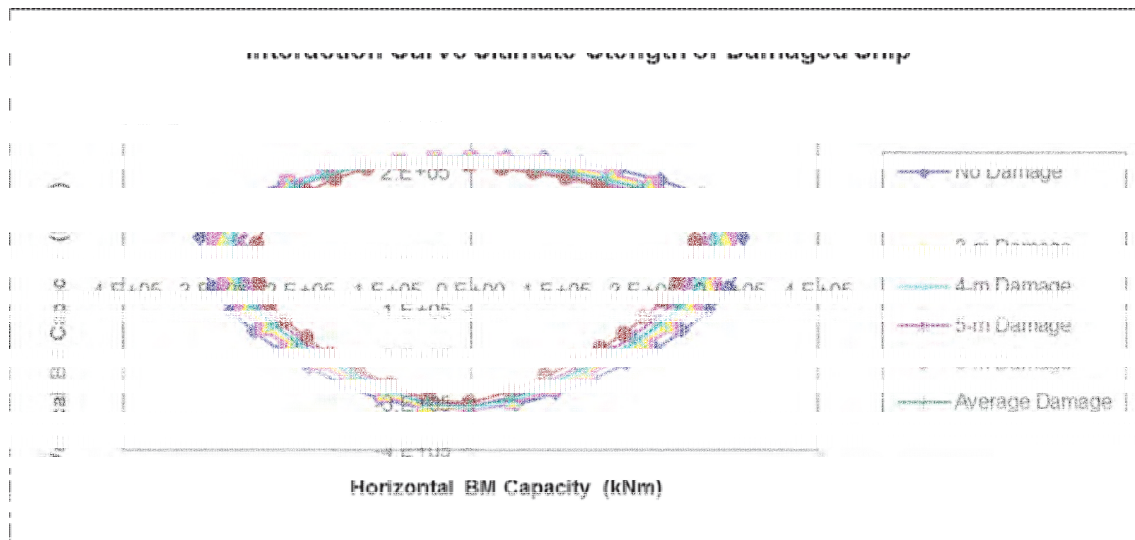

(b)

Figure 33: Interaction Curve of the Ultimate Strength of the Damaged Vessel Midship Section (a) Based on FE Calibrated load shortening Curve (b) Based On IACS load Shortening Curve

The interaction curves for the damaged sizes in Figure 33 to Figure 35 were used to estimate the mean value and the standard deviation of the horizontal and vertical moment capacities and the interaction coefficients. The mean value of the horizontal and vertical bending moment capacities are used to estimate the interaction coefficients for the damaged vessel. Table 20 and Table 21 summarise the statistics of the capacities of the damaged section.

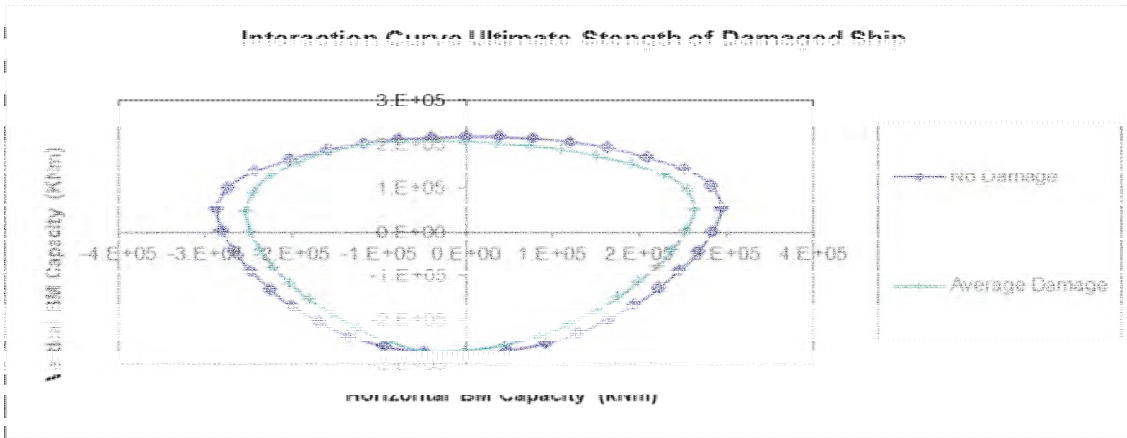

(a)

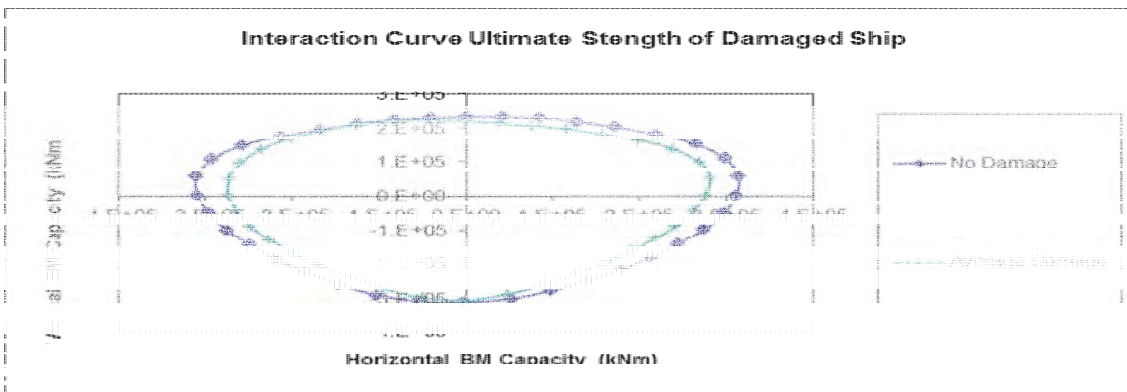

(b)

Figure 34: Ultimate Strength Interaction Curves of the Intact and Damaged Vessel Midship Section (a) Based on FE Calibrated Load Shortening Curve (b) Based On IACS load Shortening Curve

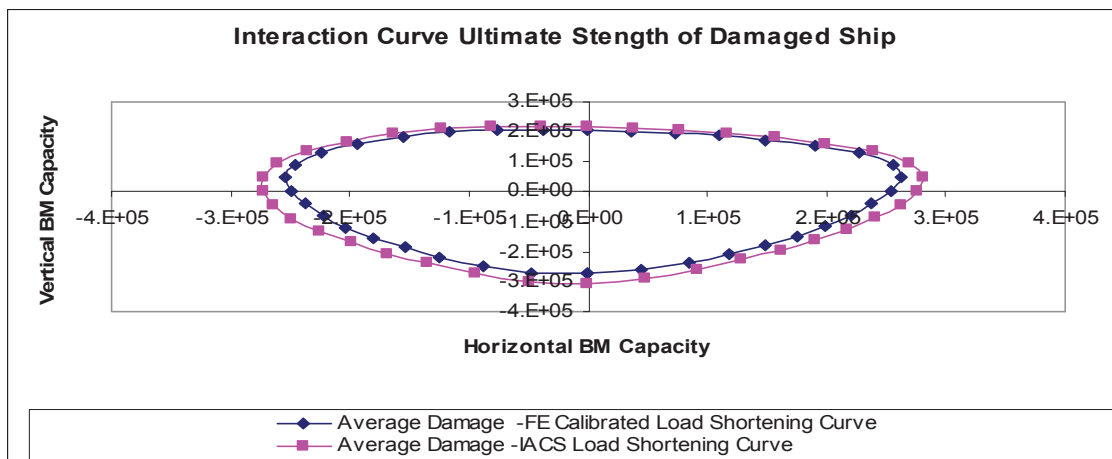

Figure 35 Average Ultimate Strength Interaction Curve of the Damaged Vessel Midship Section

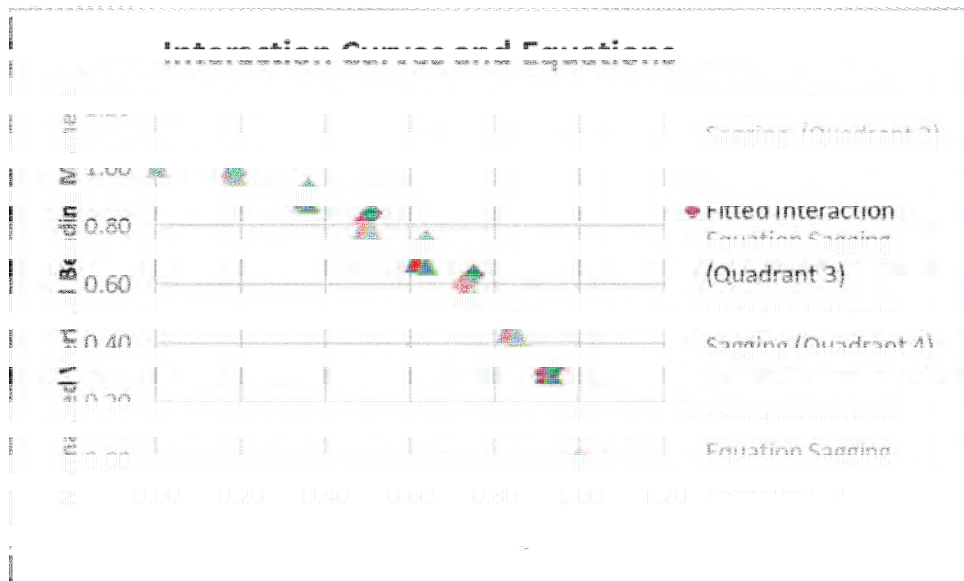
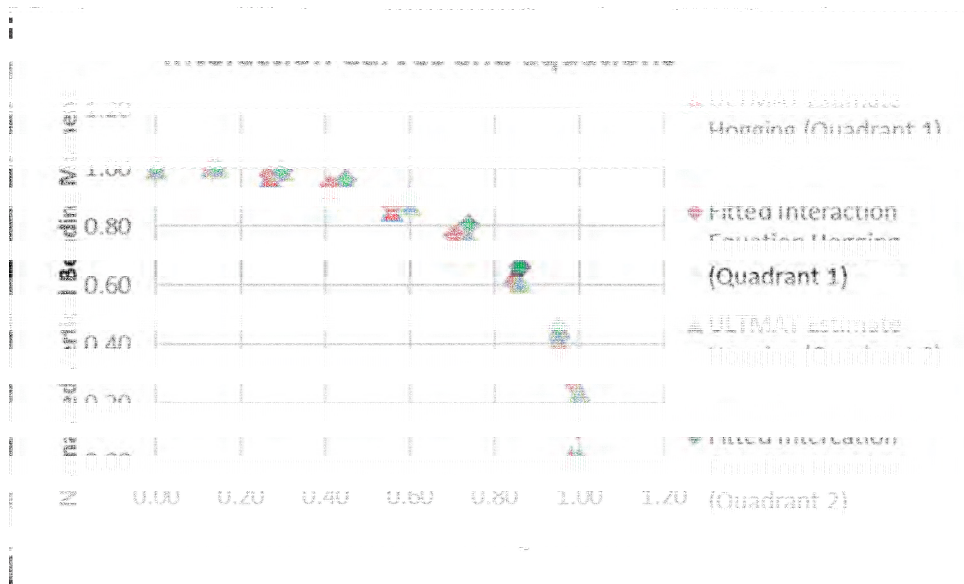

Figure 36: Normalized Ultimate Strength Interaction Curves of the Midship Section of the Damaged Vessel (IACS Load shortening Curve)

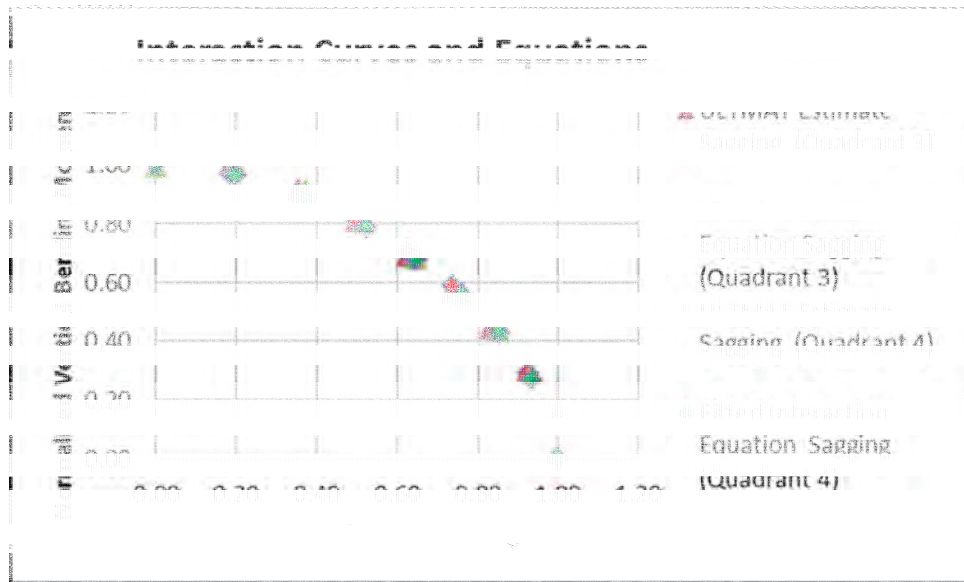
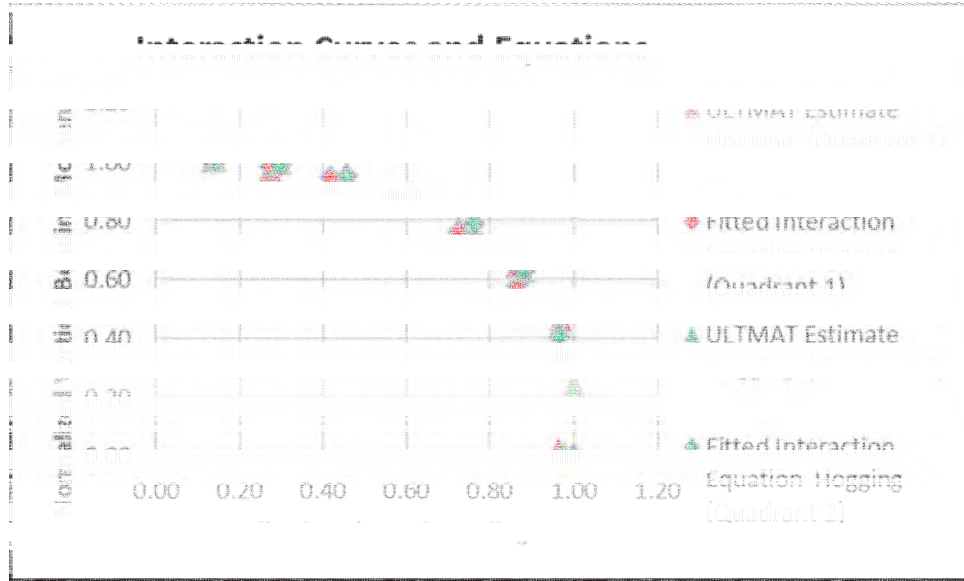

Figure 37: Normalized Ultimate Strength Interaction Curves of the Midship Section of the Damaged Vessel (FE Calibrated Load shortening Curve)

Table 20: Summary of the Ultimate Strength and the Interaction Coefficients of the Damaged Vessel Mid-Section (IACS Load Shortening Curves)

Analysis	Name	Mean Value	COV	Probability Distribution
<b>Quadrant -1:</b> IACS Load Shortening Curve	Ultimate Vertical Bending Moment Capacity (kNm)	214567.22	0.09	Weibull
	Ultimate Horizontal Bending Moment Capacity (kNm)	281032.41	0.11	Weibull
	Interaction Coefficient for Vertical Bending Moment	2.20		Fixed
	Interaction Coefficient for Horizontal Bending Moment	2.50		Fixed
<b>Quadrant -4:</b> IACS Load Shortening Curve	Ultimate Vertical Bending Moment Capacity (kNm)	- 288648.65	0.08	Weibull
	Ultimate Horizontal Bending Moment Capacity (kNm)	261701.58	0.13	Weibull
	Interaction Coefficient for Vertical Bending Moment	1.70		Fixed
	Interaction Coefficient for Horizontal Bending Moment	1.70		Fixed
<b>Quadrant -3:</b> IACS Load Shortening Curve	Ultimate Vertical Bending Moment Capacity (kNm)	- 299527.92	0.08	Weibull
	Ultimate Horizontal Bending Moment Capacity (kNm)	- 264484.23	0.12	Weibull
	Interaction Coefficient for Vertical Bending Moment	1.90		Fixed
	Interaction Coefficient for Horizontal Bending Moment	1.9		Fixed
<b>Quadrant -2:</b> IACS Load Shortening Curve	Ultimate Vertical Bending Moment Capacity (kNm)	220799.61	0.07	Weibull
	Ultimate Horizontal Bending Moment Capacity (kNm)	- 272938.24	0.13	Weibull
	Interaction Coefficient for Vertical Bending Moment	2.70		Fixed
	Interaction Coefficient for Horizontal Bending Moment	2.70		Fixed

Table 21: Summary of the Ultimate Strength and the Interaction Coefficients of the Damaged Vessel Mid-Section (FE Calibrated Load Shortening Curves)

Analysis Case	Name	Mean Value	COV	Probability Distribution
<b>Quadrant -1:</b> FE Calibrated Load Shortening Curve	Ultimate Vertical Bending Moment Capacity (kNm)	201379.88	0.08	Weibull
	Ultimate Horizontal Bending Moment Capacity (kNm)	262686.62	0.11	Weibull
	Interaction Coefficient for Vertical Bending Moment	2.20		Fixed
	Interaction Coefficient for Horizontal Bending Moment	2.50		Fixed
<b>Quadrant -4:</b> FE Calibrated Load Shortening Curve	Ultimate Vertical Bending Moment Capacity (kNm)	-259317.54	0.08	Weibull
	Ultimate Horizontal Bending Moment Capacity (kNm)	238062.99	0.12	Weibull
	Interaction Coefficient for Vertical Bending Moment	1.70		Fixed
	Interaction Coefficient for Horizontal Bending Moment	1.70		Fixed
<b>Quadrant -3:</b> FE Calibrated Load Shortening Curve	Ultimate Vertical Bending Moment Capacity (kNm)	-274566.52	0.06	Weibull
	Ultimate Horizontal Bending Moment Capacity (kNm)	-237392.79	0.11	Weibull
	Interaction Coefficient for Vertical Bending Moment	1.70		Fixed
	Interaction Coefficient for Horizontal Bending Moment	1.70		Fixed
<b>Quadrant -2:</b> FE Calibrated Load Shortening Curve	Ultimate Vertical Bending Moment Capacity (kNm)	206310.40	0.07	Weibull
	Ultimate Horizontal Bending Moment Capacity (kNm)	-253467.94	0.12	Weibull
	Interaction Coefficient for Vertical Bending Moment	2.70		Fixed
	Interaction Coefficient for Horizontal Bending Moment	2.70		Fixed

## 4.5 Estimates of the Reliabilities of the Damaged Ship

Reliability assessment was performed for the damaged vessel. First order reliability method, FORM and Monte Carlo Simulation, MCS in COMPASS were used to estimate the probabilities of failure and the importance factors of the various random variables. Table 22 summarises the probabilistic characteristics of the random variables used in the assessment.

Table 22: Summary of the Probabilistic Characteristics of the Random Variables Used for the Reliability Assessment of the Damaged Vessel.

Name	Mean Value	COV	Probability Distribution
Ultimate Vertical Bending Moment (kNm), $M_{VU}$	Depends on Quadrant Table 20 Table 21	Depends on Quadrant Table 20 Table 21	Weibull
Modelling Uncertainty Factor for Ultimate vertical bending moment, $x_{VU}$	1.00	0.10	Normal
Vertical Wave Bending Moment (kNm), $M_{VW}$	Depends on Speed Case Table 19	Depends on Speed Case Table 19	Gumbel
Modelling Uncertainty Factor for Vertical Wave Bending Moment, $x_{VW}$	1	0.10	Normal
Vertical Still Water Bending Moment (kNm), $M_{VSW}$	33534.22	0.10	Normal
Modelling Uncertainty Factor for Vertical Still Water Bending Moment, $x_{VSW}$	1.00	0.10	Normal
Vertical Load Combination Factor, $\Psi_V$	1.00		Fixed
Ultimate Horizontal Bending Moment (kNm), $M_{HU}$	Depends on Quadrant Table 20 Table 21	Depends on Quadrant Table 20 Table 21	Weibull
Modelling Uncertainty Factor for Ultimate Horizontal Bending Moment, $x_{HU}$	1.00	0.10	Normal
Horizontal Wave Bending Moment (kNm), $M_{HW}$	Depends on Speed Case Table 19	Depends on Speed Case Table 19	Gumbel
Modelling Uncertainty Factor for Horizontal Wave Bending Moment, $x_{HW}$	1.00	0.10	Normal
Horizontal Still Water Bending Moment (kNm), $M_{HSW}$	1643.32	0.10	Normal
Modelling Uncertainty Factor Horizontal Still Water Bending Moment, $x_{HSW}$	1.00	0.10	Normal
Horizontal Load Combination Factor, $\Psi_H$	1.00		Fixed

Name	Mean Value	COV	Probability Distribution
Vertical interaction Coefficient, $m$	Depends on Quadrant Table 20 Table 21		Fixed
Horizontal interaction Coefficient, $n$	Depends on Quadrant Table 20 Table 21		Fixed

Table 23 and Table 24 summarise the results of the structural integrity of the damaged vessel. The following conclusions are drawn from the tables:

- The interaction equation model, which is a better model for representing the capacities and loads on the damaged vessel, gave estimates of probabilities of failures that were always smaller than the estimates from the linear model. Since the linear model is the less accurate model it is reasonable to conclude that estimates of failure probabilities based on it are also less accurate. The failure probabilities from the linear model were higher than the failure probabilities from the interaction model because the linear model uses only the vertical bending capacity of the ship (which is small) and vertical loads on the ship (which is high). It neglects the modulating or interacting effect of the horizontal bending capacity of the ship (which is large) and the horizontal load (which is small). This underscores the need to use high quality deterministic models when performing reliability analysis.
- For both the linear and the interaction limit state functions, and the FE calibrated and the IACS load shortening curves, the first quadrants of structural strength, which represents hogging failure mode, gave the highest estimates of failure probabilities and is therefore the quadrant that governs the failure of the damaged vessel.
- The higher the vessel speed, the higher the probability of failure, and vice versa.
- FORM and Monte Carlo Simulation estimates of reliabilities were very close to each other. Since FORM and MCS gave very close estimates of the failure probabilities, FORM should be used to estimate the reliability of damaged ship structures without undermining the accuracy of the results for cases where there may be a need to use very costly models such as the finite element method to determine structural capacities.
- Estimates of the failure probabilities computed using the IACS load shortening curves were always lower than those based on the FE calibrated curves, implying that the FE calibrated curves give more conservative results. This result is consistent with the estimates of the deterministic structural strength shown in Figure 34.

Table 23: Summary of the Probabilities of Failures of the Midship Section of the Damaged Vessel Using IACS Load Shortening Curves

Case No	Speed (knots)	Strength Quadrant	Probability of Failure (Linear Model)		Probability of Failure (Interaction Equation Model)	
			FORM	MCS	FORM	MCS
Case 1	3 and 6	1	7.19E-04	7.24E-04	2.09E-04	1.79E-04
		4	6.80E-06	7.00E-06	5.13E-07	3.97E-07
		3	2.27E-06	2.34E-06	1.49E-07	1.59E-07
		2	3.36E-04	3.37E-04	6.05E-05	5.08E-05
Case 2	6 and 9	1	1.56E-03	1.55E-03	5.82E-04	5.03E-04
		4	2.09E-05	2.15E-05	2.55E-06	2.29E-06
		3	1.11E-05	1.13E-05	1.08E-06	9.50E-07
		2	1.09E-03	1.09E-03	3.69E-04	3.15E-04
Case 3	9 and 12	1	2.13E-03	2.09E-03	8.80E-04	7.63E-04
		4	3.36E-05	3.32E-05	4.86E-06	4.53E-06
		3	9.81E-06	9.80E-06	5.391E-07	4.12E-07
		2	1.15E-03	1.13E-03	3.52E-04	2.94E-04

Table 24: Summary of Probabilities of Failures of the Midship Section of the Damaged Vessel Using FE Calibrated Load Shortening Curves

Case No	Speed (knots)	Strength Quadrant	Probability of Failure (Linear Model)		Probability of Failure (Interaction Equation Model)	
			FORM	MCS	FORM	MCS
Case 1	3 and 6	1	1.40E-03	1.38E-03	4.52E-04	3.86E-04
		4	3.20E-05	3.18E-05	3.41E-06	3.11E-06
		3	6.60E-06	6.54E-06	3.73E-07	3.83E-07
		2	1.02E-03	1.01E-03	2.98E-04	2.56E-04
Case 2	6 and 9	1	2.92E-03	2.87E-03	1.21E-03	1.04E-03
		4	9.12E-05	9.60E-05	1.54E-05	1.47E-05
		3	2.77E-05	2.74E-05	2.47E-06	2.24E-06
		2	1.95E-03	1.89E-03	6.81E-04	5.74E-04
Case 3	9 and 12	1	3.89E-03	3.82E-03	1.78E-03	1.54E-03
		4	1.41E-04	1.45E-04	2.78E-05	2.58E-05
		3	5.73E-05	5.81E-05	8.52E-06	8.13E-06
		2	2.97E-03	2.91E-03	1.41E-03	1.27E-03

The importance factors of the random variables involved in the reliability analyses were computed for all 24 cases listed in Table 23 and Table 24. Figure 38 to Figure 43 show the importance factors for the strength quadrant that governs the failure of the damaged vessel. The

other important factors, which have similar profiles to Figure 38 to Figure 43, are summarised in Annex B. The following are observed from Figure 38 to Figure 43.

- When using the interaction equation model, three parameters: the vertical wave bending moment, the modelling uncertainty of the vertical wave bending moment and the ultimate vertical bending moment, govern the failure of the damaged vessel. Of the three, the vertical wave bending moment and its uncertainty are the main parameters that drive the failure of the intact vessel. This is closely followed by the uncertainty in the ultimate vertical bending moment of the section. Unlike in the intact vessel, the ultimate vertical bending moment of the damaged vessel is a more important random variable than the ultimate vertical bending moment of the intact vessel. This reflects the impact of the uncertainties associated with damaged to the vessel.
- Unlike the reliability assessment based on the interaction model, when using the linear equation model, four parameters: the vertical wave bending moment, the modelling uncertainty of the ultimate vertical bending moment, the modelling uncertainty of the vertical wave bending moment and the ultimate vertical bending moment, govern the failure of the damaged vessel. Although of the four parameters, the vertical wave bending moment and its uncertainty are the main parameters the drive the failure of the vessel, the combined impact of the modelling uncertainty of the ultimate vertical bending moment and the ultimate vertical bending moment is almost in the same ball park as the vertical bending moment. This again reflects the impact of uncertainties associated with the damaged sizes on the structural integrity of the damaged vessel and also underscores the need to use a structural model that more accurately estimates the failure mode of the damaged structure under consideration.
- In general the higher the vessel speed, as represented by the higher values and uncertainties in the vertical bending moment, the higher the importance factor of the vertical bending moment. This demonstrates the importance of using a model that accurately estimates the RAOs on the vessel for the vessel speed under considering.



(a)

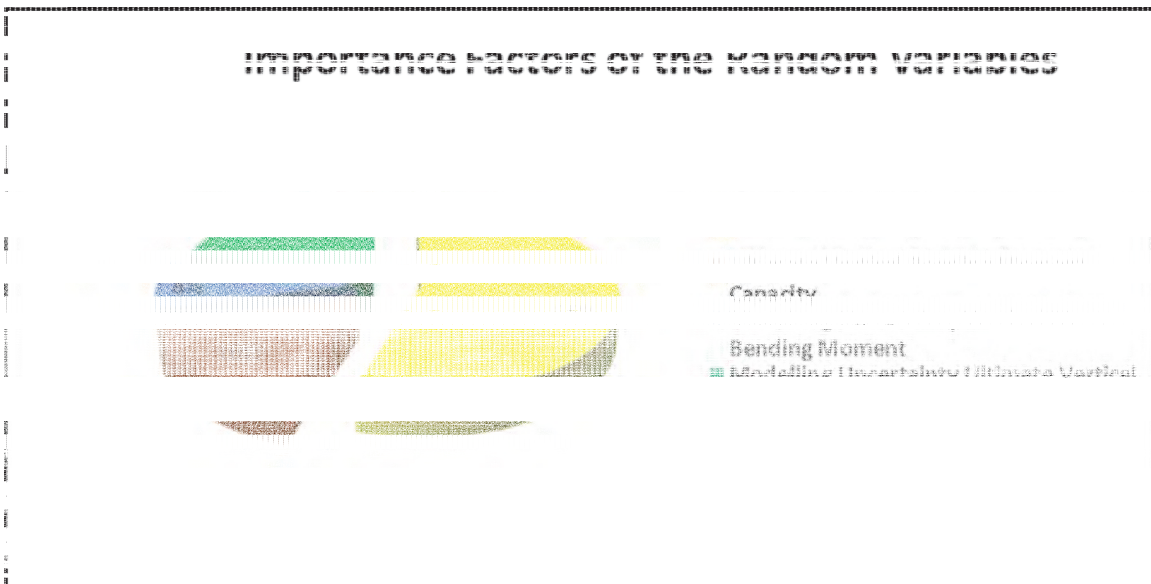

(b)

Figure 38: The Importance Factors of the Random Variables in Case 1 Damaged Vessel; 3 and 6 knots, IACS Interaction Curve (a) Interaction Equation Model (b) Linear Model

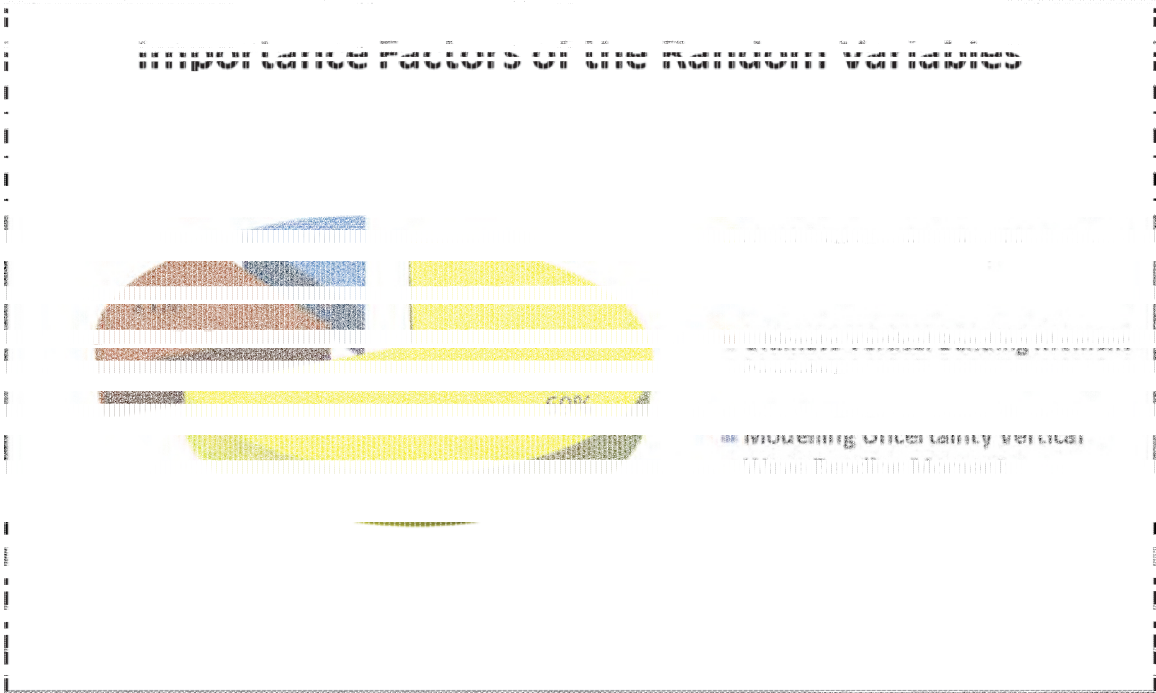

(a)

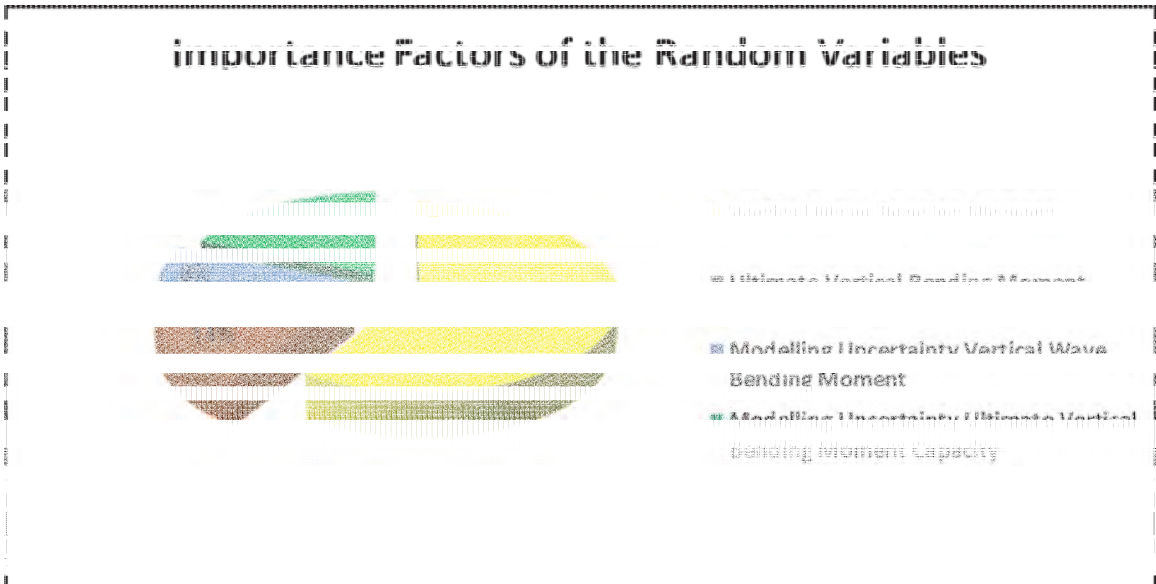

(b)

Figure 39: The Importance Factors of the Random Variables in Case 2 Damaged Vessel; 6 and 9 knots, IACS Interaction Curve (a) Interaction Equation Model (b) Linear Model

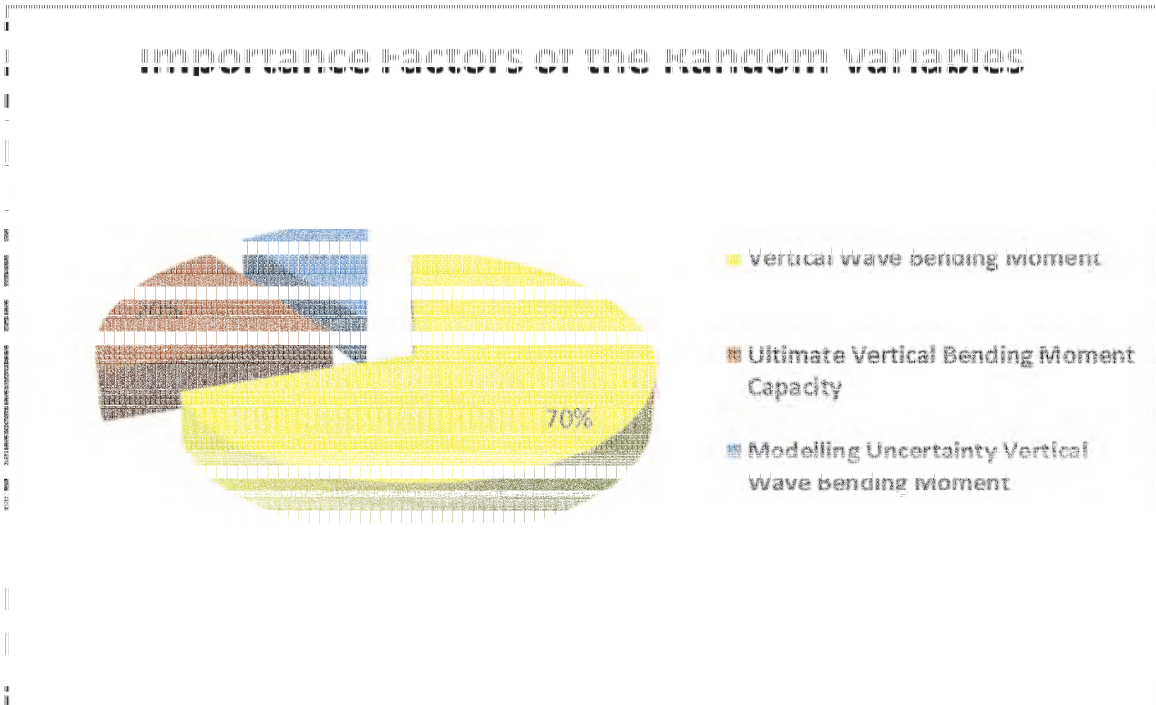

(a)

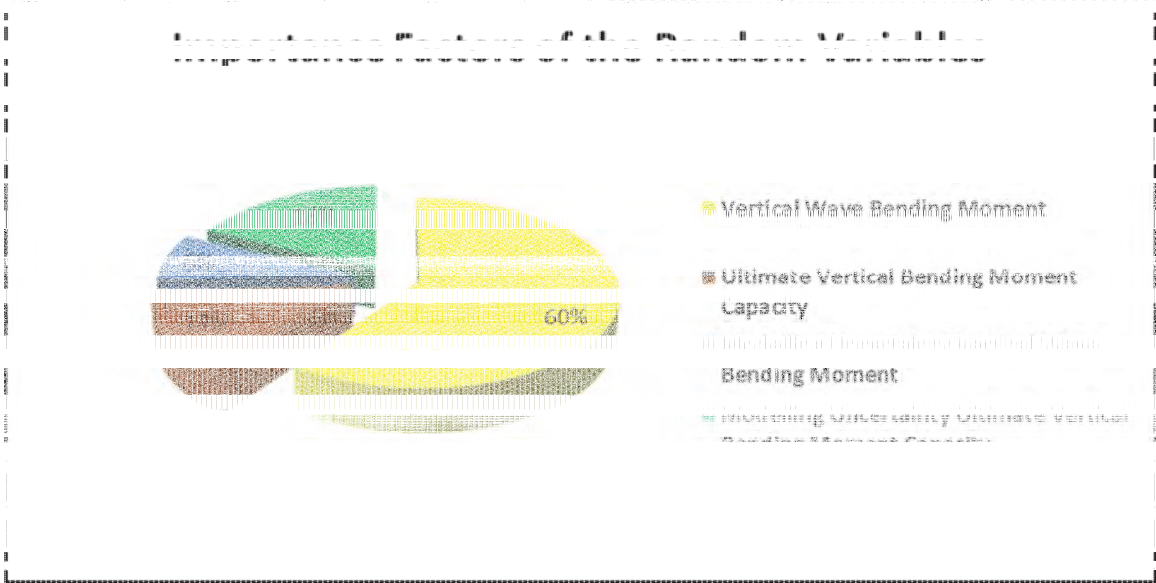

(b)

Figure 40: The Importance Factors of the Random Variables in Case 3 Damaged Vessel; 9 and 12 knots, IACS Interaction Curve (a) Interaction Equation Model (b) Linear Model

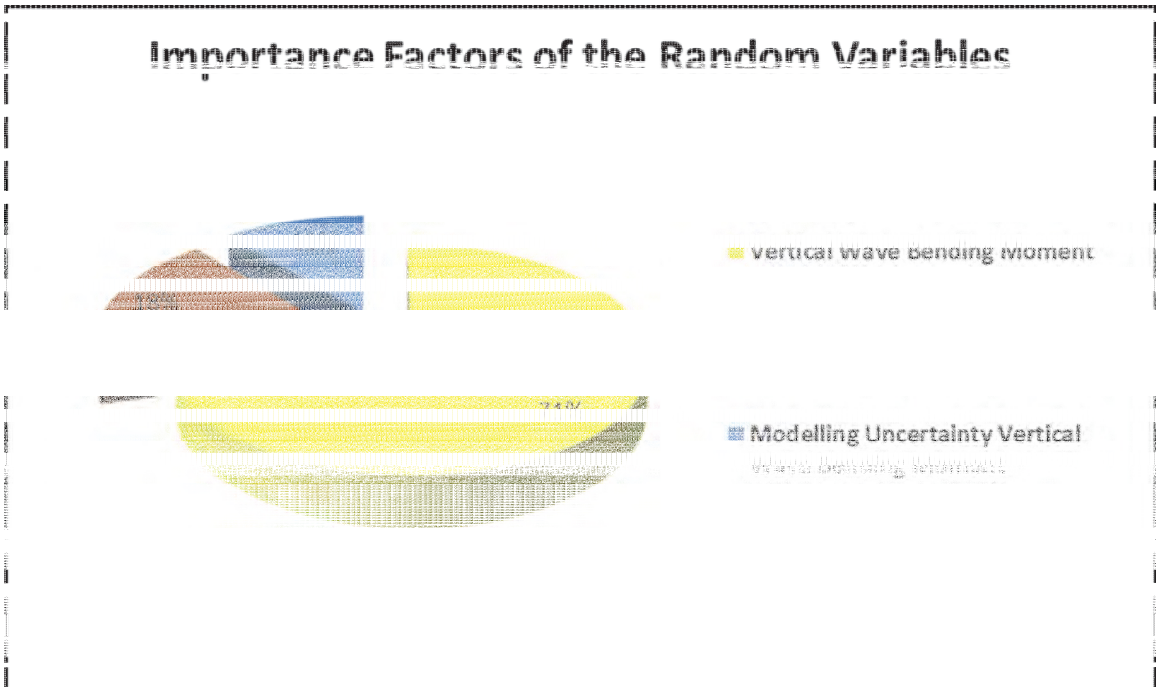

(a)

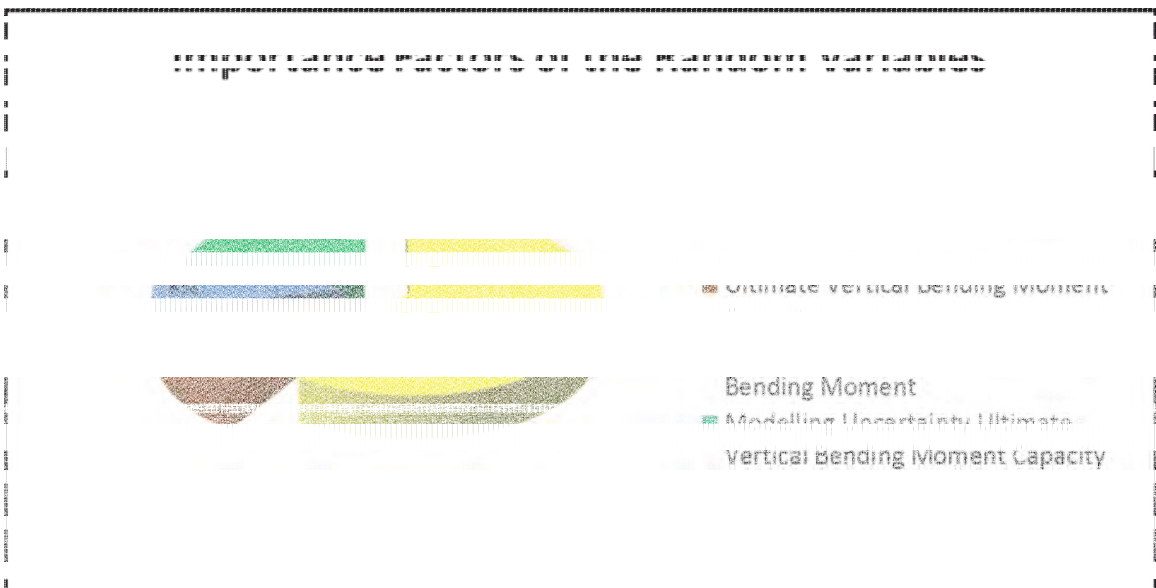

(b)

Figure 41: The Importance Factors of the Random Variables in Case 1 Damaged Vessel; 3 and 6 knots, FE Calibrated Interaction Curve (a) Interaction Equation Model (b) Linear Model

## Importance Factors of the Random Variables

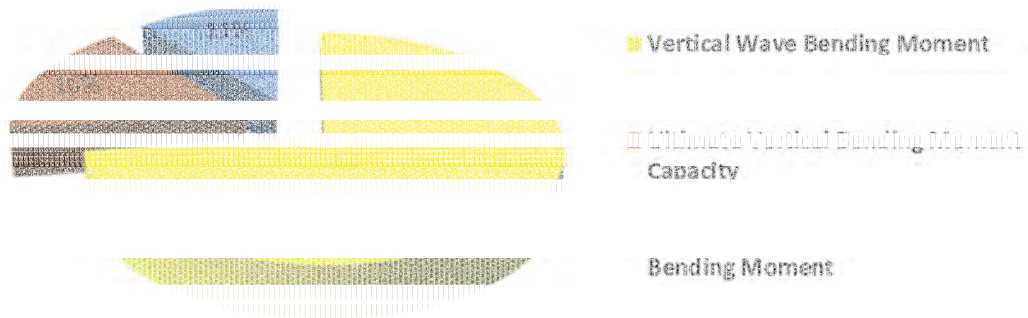

(a)

## Importance Factors of the Random Variables

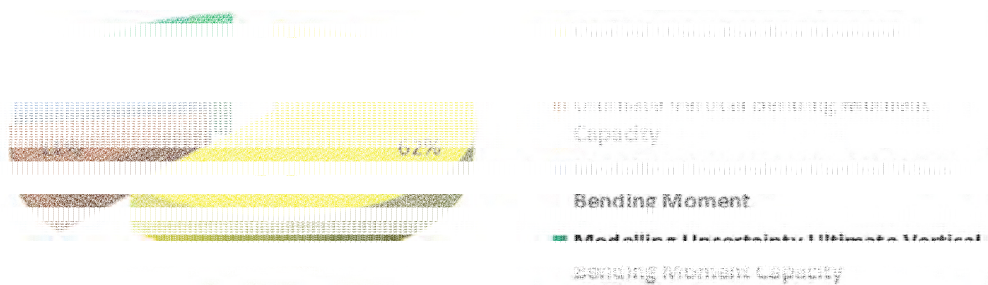

(b)

Figure 42: The Importance Factors of the Random Variables in Case 2 Damaged Vessel; 6 and 9 knots, FE Calibrated Interaction Curve (a) Interaction Equation Model (b) Linear Model

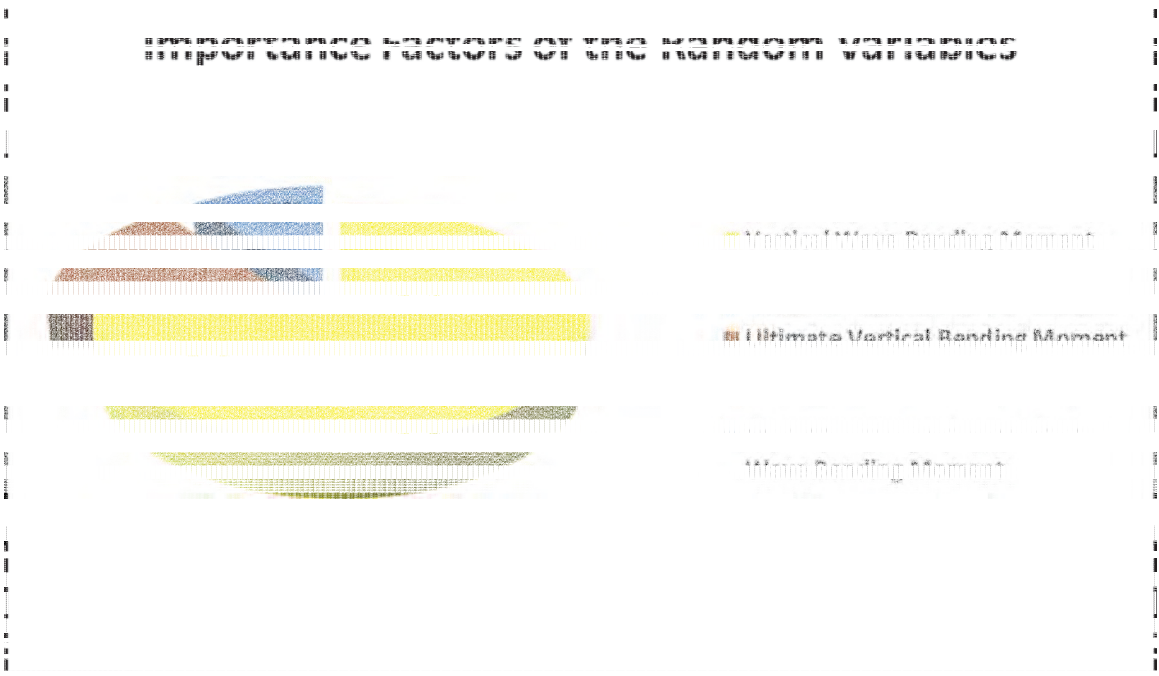

(a)

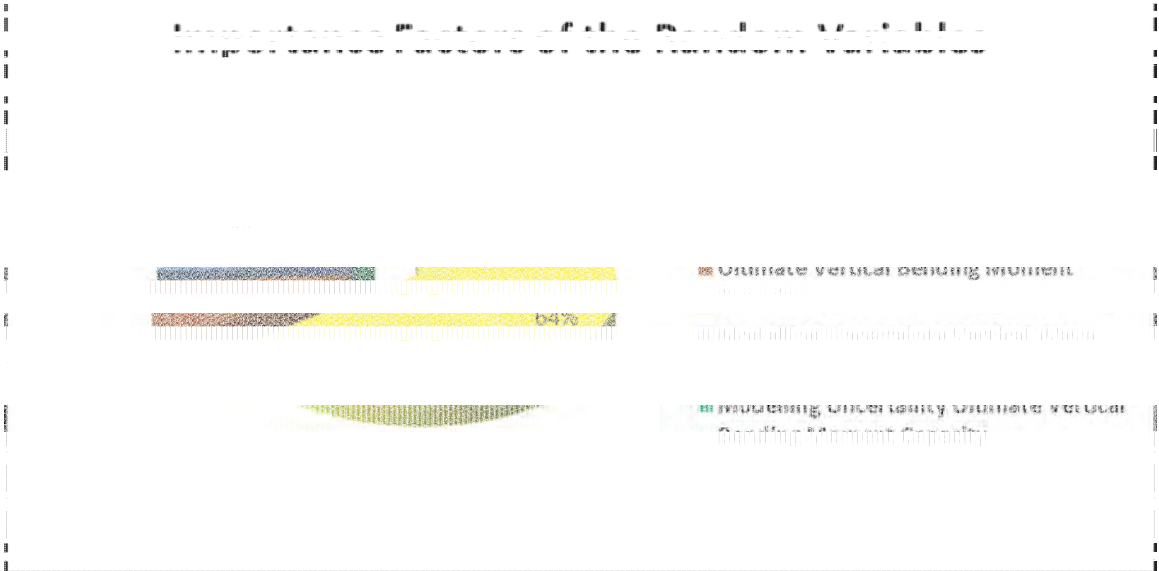

(b)

Figure 43: The Importance Factors of the Random Variables in Case 3 Damaged Vessel; 9 and 12 knots, FE Calibrated Interaction Curve (a) Interaction Equation Model (b) Linear Model

#### 4.5.1 Comparison of Estimates of Reliabilities for the Damaged and the Intact Vessel

Table 25 and Table 26 summarise the dominant failure probabilities for the damaged and the intact vessel. Typical importance factors for the intact and the damaged vessel are summarised in Figure 44 to Figure 47. The following conclusion can be drawn from the tables and the figures.

- For a specified operational speed, strength model and limit state function, the probability of failure of the damaged vessel was always higher than that of the intact vessel for operations in similar sea states over different time periods. This result cannot be generalised at this time because there were some limitations in the current analysis. First, the extreme loads on the intact vessel were not based on the lifetime operational profile of the vessel, and second, the estimate of the hydrodynamics loads on the damaged vessel assumed that all the damage occurs under water and a loss of buoyancy was not accounted for in this case. Thus the impact of extreme horizontal wave load was not captured in the current analysis.
- When dealing with the interaction equation limit state function, the three parameters that governed the failure of the damaged and the intact vessel were the vertical wave bending moment, the ultimate vertical bending moment and the modelling uncertainty of the vertical wave bending moment. In both the damaged and the intact vessel, the vertical wave bending moment was always the dominant random variable. This was followed by the ultimate vertical bending moment in the damaged case and by the modelling uncertainty factor of the vertical wave bending moment in the intact case. The ordered importance factor is shown below:

Ordered Importance Factor	Intact Vessel	Damaged Vessel
First	Vertical Wave Bending Moment	Vertical Wave Bending Moment
Second	Modelling Uncertainty Vertical Wave Bending Moment	Ultimate Vertical Bending Moment
Third	Ultimate Vertical Bending Moment Ship	Modelling Uncertainty Vertical Wave Bending Moment

- When dealing with the linear limit state function the four parameters that govern the failure of the damaged and the intact vessel were the vertical wave bending moment, the modelling uncertainty factor of the ultimate vertical bending moment, the ultimate vertical bending moment and the modelling uncertainty of the vertical wave bending moment. In both the damaged and the intact vessel, the vertical wave bending moment was again the dominant random variable and was closely followed by the modelling uncertainty factor of the ultimate vertical bending moment. The third most important random variable for the damaged vessel was the ultimate strength of the damaged vessel while it was the modelling uncertainty factor of the vertical wave bending moment for the intact case. The ordered importance factor is shown below

Ordered Importance Factor	Intact Vessel	Damaged Vessel
First	Vertical Wave Bending Moment	Vertical Wave Bending Moment
Second	Modelling Uncertainty Ultimate Vertical Bending Moment	Modelling Uncertainty Ultimate Vertical Bending Moment
Third	Modelling Uncertainty Vertical Wave Bending Moment	Ultimate Vertical Bending Moment
Fourth	Ultimate Vertical Bending Moment	Modelling Uncertainty Vertical Wave Bending Moment

- The horizontal components of the loads and the capacities did not affect the results of the reliability assessment primarily because of the limitation of the estimates of the wave loads on the damaged ship. This situation will be remedied in future study by using a loading scenario that is more realistic of gross damage.

Table 25: Comparison of the Probabilities of Failures of the Intact and the Damaged Vessel Using IACS Load Shortening Curves

Case No	Speed (knots)	Vessel Condition	Probability of Failure (Linear Model)		Probability of Failure (Interaction Equation Model)	
			FORM	MCS	FORM	MCS
Case 1	3 and 6	Damaged Vessel	7.19E-04	7.24E-04	2.09E-04	1.79E-04
		Intact Vessel	3.69E-04	3.55E-04	5.57E-05	4.78E-05
Case 2	6 and 9	Damaged Vessel	1.56E-03	1.55E-03	5.82E-04	5.03E-04
		Intact Vessel	9.22E-04	8.86E-04	2.21E-04	1.78E-04
Case 3	9 and 12	Damaged Vessel	2.13E-03	2.09E-03	8.80E-04	7.63E-04
		Intact Vessel	1.36E-03	1.30E-03	3.94E-04	3.23E-03

Table 26: Comparison of the Probabilities of Failures of the Intact and the Damaged Vessel Using FE Calibrated Load Shortening Curves

Case No	Speed (knots)	Vessel Condition	Probability of Failure (Linear Model)		Probability of Failure (Interaction Equation Model)	
			FORM	MCS	FORM	MCS
Case 1	3 and 6	Damaged Vessel	1.40E-03	1.38E-03	4.52E-04	3.86E-04
		Intact Vessel	8.49E-04	8.18E-04	1.95E-04	1.61E-04
Case 2	6 and 9	Damaged Vessel	2.92E-03	2.87E-03	1.21E-03	1.04E-03
		Intact Vessel	1.81E-03	1.72E-03	5.56E-04	4.70E-04
Case 3	9 and 12	Damaged Vessel	3.89E-03	3.82E-03	1.78E-03	1.54E-03
		Intact Vessel	2.58E-03	2.46E-03	9.30E-04	7.84E-04

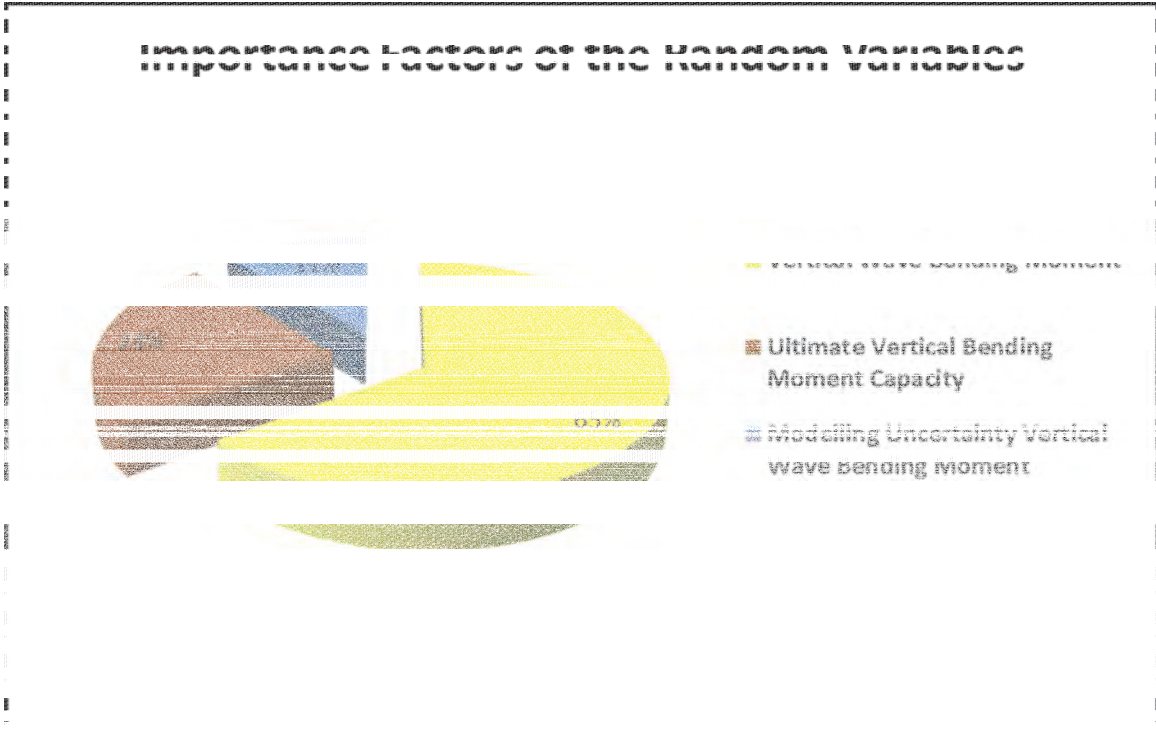

(a)

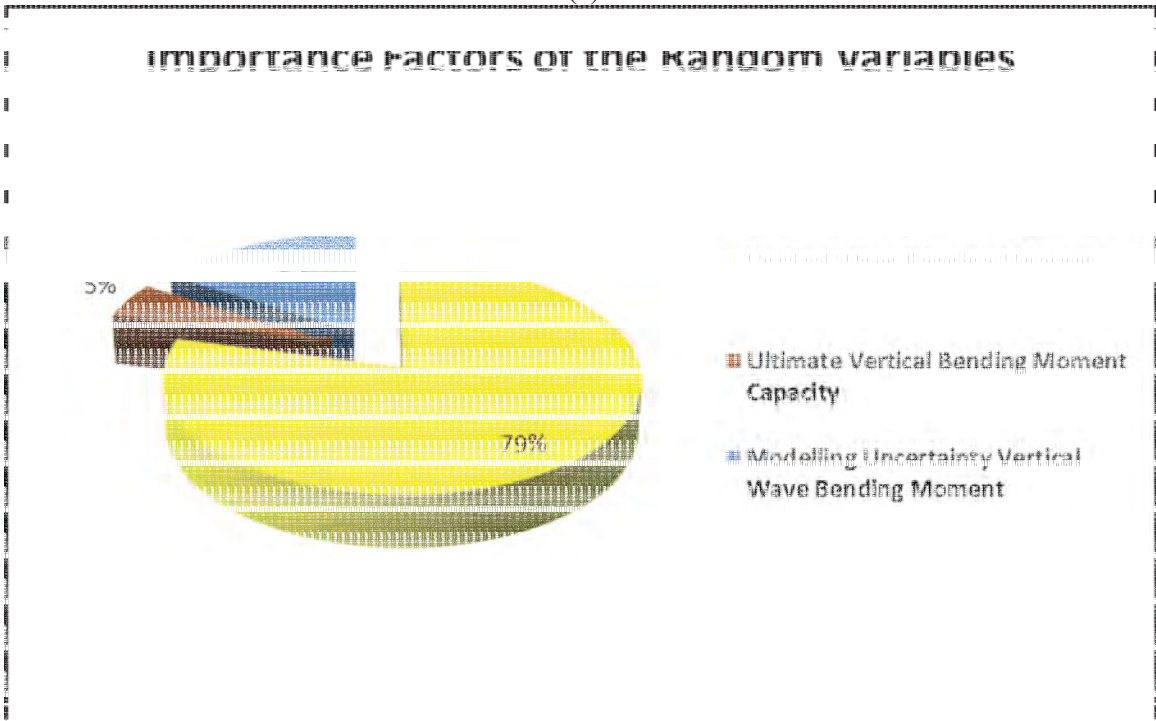

(b)

Figure 44: Comparison of a Typical Importance Factor for the Random Variables Using Interaction Equation Model (IACS) (a) Damaged Vessel (b) Intact Vessel

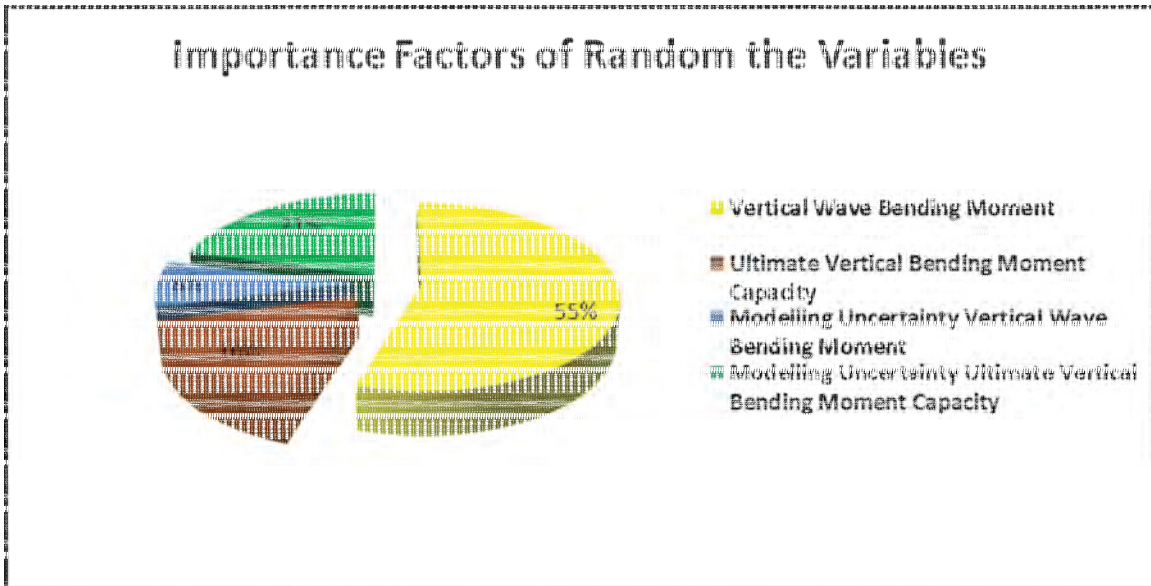

(a)

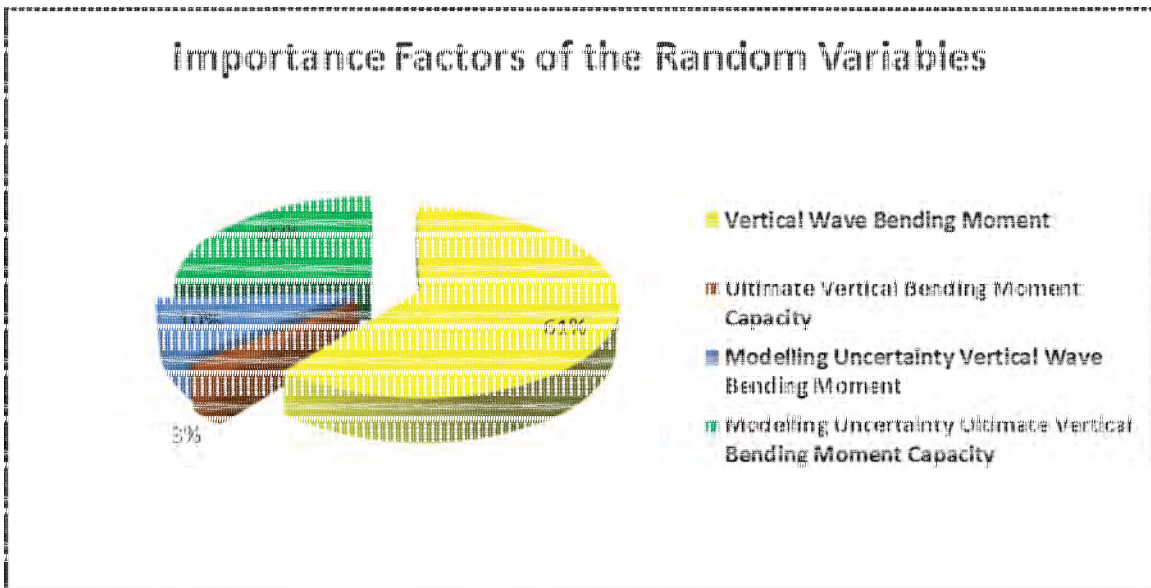

(b)

Figure 45: Comparison of a Typical Importance Factor for the Random Variables Using Linear Equation Model (IACS) (a) Damaged Vessel (b) Intact Vessel

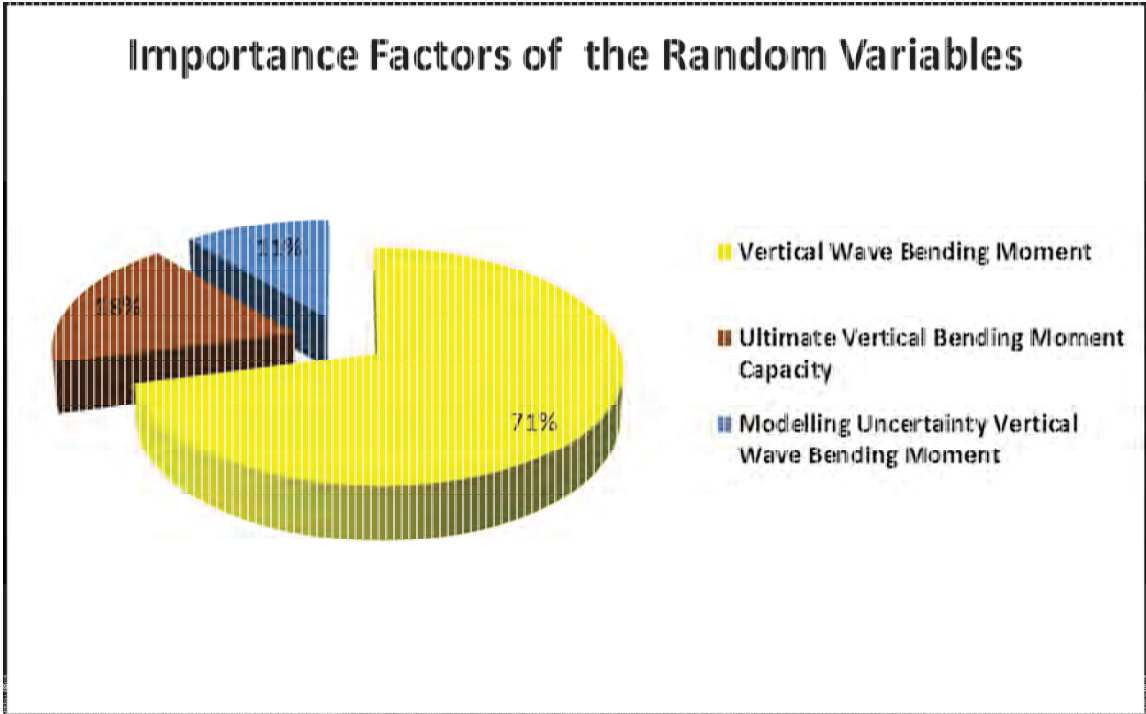

(a)

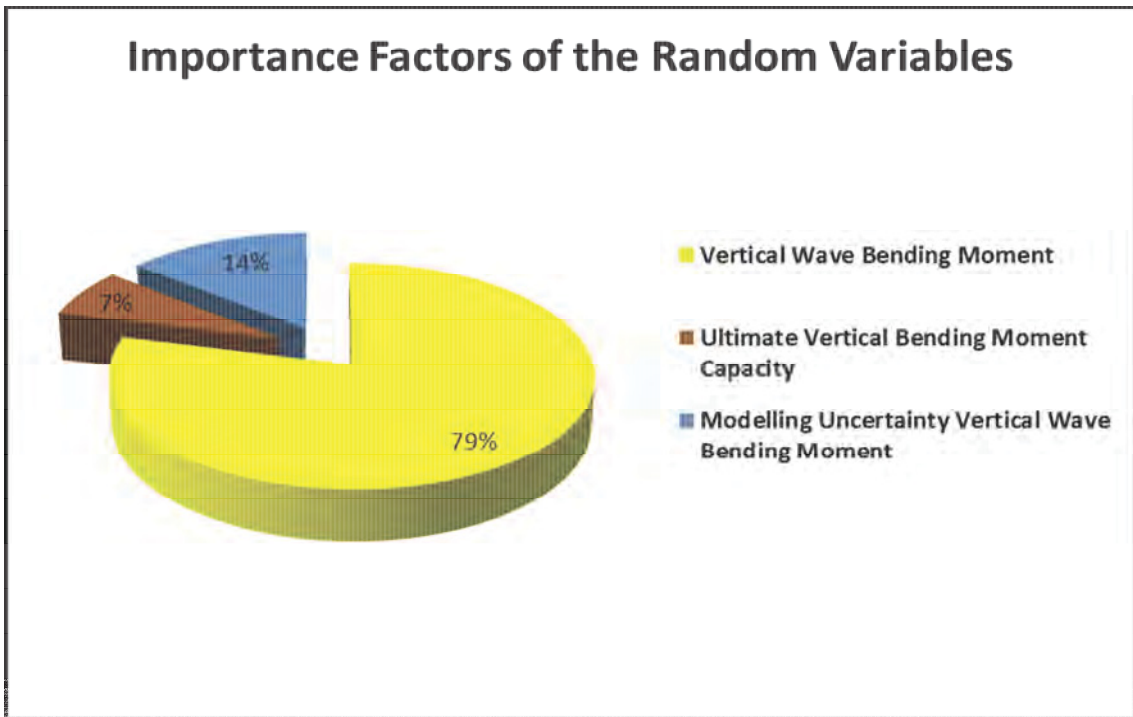

(b)

Figure 46: Comparison of a Typical Importance Factor for the Random Variables Using Interaction Equation Model (FE Calibrated) (a) Damaged Vessel (b) Intact Vessel

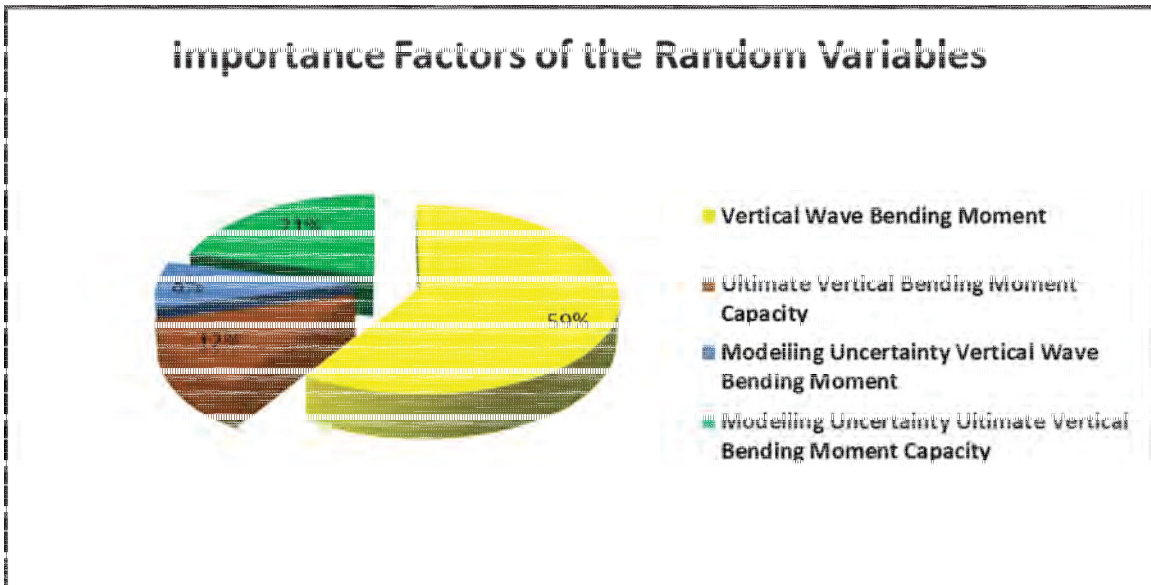

(a)

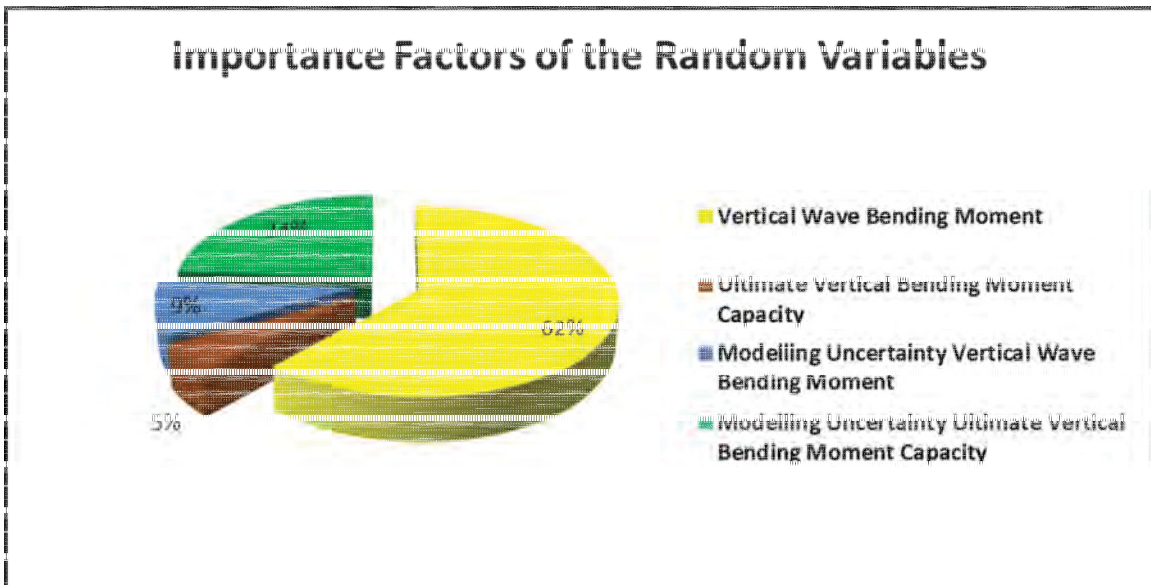

(b)

Figure 47: Comparison of a Typical Importance Factor for the Random Variables Using Linear Equation Model (FE Calibrated) (a) Damaged Vessel (b) Intact Vessel

## 5 Summary, Conclusions and Recommendations

---

### 5.1 Summary

This is the Phase III work of an overall study to investigate the probability of failure of damaged ship structures. It was focused on the application of the methodology for reliability analysis of gross damage to ships developed in Phase II to a damaged ship. The specific tasks that were performed are:

- Definition of the ship characteristics and operation profile in the intact and the damaged state;
- Determination of the damage scenarios and damage sizes;
- Estimation of the loads on the intact and the damaged ship;
- Estimation of the ultimate strength of the intact and the damaged ship; and
- Estimation of the probabilistic structural integrity of the intact and the damaged ship.

Structural integrity assessment was performed on the midship section of the ex-HMCS Nipigon. SIMCOL and COMPASS were used to estimate and calibrate the damage on the vessel. Under the selected collision scenario, the mean value and the standard deviation of the maximum damaged length are 4.6 m and 4.0 m, respectively, and the mean value and the standard deviation of the maximum penetration are 1.6 m and 1.5 m, respectively.

#### 5.1.1 Estimates of the Loads on the Intact and the Damaged Ship

Three sets of vessels speeds, 3 and 6 knots; 6 and 9 knots and 9 and 12 knots along with the operational profiles defined in Table 8 and Table 17 were used to determine the wave loads on the ship. WAVELOAD was used to compute the response amplitude operators, RAOs, of the intact and the damaged ship. The extreme values of the wave loads on the intact and the damaged ship were computed and calibrated using COMPASS and are summarised below:

*Table 27: Summary of the Extreme Wave Loads on the Intact and the Damaged Ship*

Load Case	Name	Mean Value	COV	Probability Distribution
<b>Damaged Ship</b>				
3 and 6 knots	Vertical Wave Bending Moment (kNm)	48968.26	0.59	Gumbel
	Horizontal Wave Bending Moment (kNm)	17569.30	0.81	Gumbel
6 and 9 knots	Vertical Wave Bending Moment (kNm)	51870.00	0.61	Gumbel

Load Case	Name	Mean Value	COV	Probability Distribution
	Horizontal Wave Bending Moment (kNm)	18017.00	0.83	Gumbel
9 and 12 knots	Vertical Wave Bending Moment (kNm)	52599.00	0.63	Gumbel
	Horizontal Wave Bending Moment (kNm)	17535.00	0.85	Gumbel
<b>Intact Ship</b>				
3 and 6 knots	Vertical Wave Bending Moment (kNm)	53156.97	0.59	Gumbel
	Horizontal Wave Bending Moment (kNm)	18862.87	0.81	Gumbel
6 and 9 knots	Vertical Wave Bending Moment (kNm)	56303.25	0.61	Gumbel
	Horizontal Wave Bending Moment (kNm)	19328.98	0.83	Gumbel
9 and 12 knots	Vertical Wave Bending Moment (kNm)	57209	0.63	Gumbel
	Horizontal Wave Bending Moment (kNm)	18834	0.85	Gumbel

TRIDENT was used to estimate the still water bending moment on the damaged and the ship. The values of the loads are summarised below:

*Table 28: Summary of the Still Water Loads on the Intact and the Damaged Ship*

Name	Mean Value	COV	Probability Distribution
Vertical Still Water Bending Moment (kNm)	33534.22	0.10	Normal
Horizontal Still Water Bending Moment (kNm)	1643.32	0.10	Normal

### 5.1.2 Estimates of the Capacities of the Intact and the Damaged Ship

The ultimate strength of the midship section of the intact and the damaged vessel was computed using ULTIMAT. The damage size feature of ULTIMAT was used to estimate the damaged ship ultimate strength interaction curves for damage sphere sizes of 2 m, 3 m, 4 m, 5 m, and 6 m. COMPASS was then used to determine the mean values and standard deviations of the ultimate strength of the damaged vessel. Interaction coefficients were developed for the interaction curves. The results are summarised below for the strength quadrant that governed the failure of the vessel.

Table 29: Summary of the Ultimate Strength Capacities of the Intact and the Damaged Ship

Load Case	Name	Mean Value	COV	Probability Distribution
<b>Intact Vessel- IACS Load Shortening Curves</b>				
<b>Quadrant -2:</b>	Ultimate Vertical Bending Moment Capacity (kNm)	228450.60	0.04	Weibull
	Ultimate Horizontal Bending Moment Capacity (kNm)	310278.00	0.04	Weibull
	Interaction Coefficient for Vertical Bending Moment	2.30		Fixed
	Interaction Coefficient for Horizontal Bending Moment	2.30		Fixed
<b>Damaged Vessel- IACS Load Shortening Curves</b>				
<b>Quadrant -1:</b>	Ultimate Vertical Bending Moment Capacity (kNm)	214567.22	0.09	Weibull
	Ultimate Horizontal Bending Moment Capacity (kNm)	281032.41	0.11	Weibull
	Interaction Coefficient for Vertical Bending Moment	2.20		Fixed
	Interaction Coefficient for Horizontal Bending Moment	2.50		Fixed
<b>Intact Vessel- FE Calibrated Load Shortening Curves</b>				
<b>Quadrant -2:</b>	Ultimate Vertical Bending Moment Capacity (kNm)	217167.60	0.04	Weibull
	Ultimate Horizontal Bending Moment Capacity (kNm)	287192.80	0.04	Weibull
	Interaction Coefficient for Vertical Bending Moment	2.30		Fixed
	Interaction Coefficient for Horizontal Bending Moment	2.30		Fixed
<b>Damaged Vessel- FE Calibrated Load Shortening Curves</b>				
<b>Quadrant -1:</b>	Ultimate Vertical Bending Moment Capacity (kNm)	201379.88	0.08	Weibull
	Ultimate Horizontal Bending Moment Capacity (kNm)	262686.62	0.11	Weibull
	Interaction Coefficient for Vertical Bending Moment	2.20		Fixed
	Interaction Coefficient for Horizontal Bending Moment	2.50		Fixed

### 5.1.3 Estimates of the Reliabilities of the Intact and the Damaged Ship

COMPASS was used to estimate the reliabilities and the important factors of the random variables of the intact and the damaged vessel. Both the first order reliability method, FORM, and the Monte Carlo Simulation method, MCS, were employed. The analyses were performed

with the linear and the interaction equation limit state functions. Results of the probabilities of failures are summarised below.

Table 30: Summary of the Structural Reliabilities of the Intact and the Damaged Ship

Case No	Speed (knots)	Vessel Condition	Probability of Failure (Linear Model)		Probability of Failure (Interaction Equation Model)	
<b>IACS Load Shortening Curves</b>						
			<b>FORM</b>	<b>MCS</b>	<b>FORM</b>	<b>MCS</b>
Case 1	3 and 6	Damaged Vessel	7.19E-04	7.24E-04	2.09E-04	1.79E-04
		Intact Vessel	3.69E-04	3.55E-04	5.57E-05	4.78E-05
Case 2	6 and 9	Damaged Vessel	1.56E-03	1.55E-03	5.82E-04	5.03E-04
		Intact Vessel	9.22E-04	8.86E-04	2.21E-04	1.78E-04
Case 3	9 and 12	Damaged Vessel	2.13E-03	2.09E-03	8.80E-04	7.63E-04
		Intact Vessel	1.36E-03	1.30E-03	3.94E-04	3.23E-03
<b>FE Calibrated Load Shortening Curves</b>						
Case 1	3 and 6	Damaged Vessel	1.40E-03	1.38E-03	4.52E-04	3.86E-04
		Intact Vessel	8.49E-04	8.18E-04	1.95E-04	1.61E-04
Case 2	6 and 9	Damaged Vessel	2.92E-03	2.87E-03	1.21E-03	1.04E-03
		Intact Vessel	1.81E-03	1.72E-03	5.56E-04	4.70E-04
Case 3	9 and 12	Damaged Vessel	3.89E-03	3.82E-03	1.78E-03	1.54E-03
		Intact Vessel	2.58E-03	2.46E-03	9.30E-04	7.84E-04

## 5.2 Conclusions

The results of the current analysis indicate that for a specified operational speed, strength model, load shortening curve and limit state function, the probability of failure of the damaged vessel is always higher than that of the intact vessel. When the reliability assessment is based on the interaction equation limit state function, the failure of the damaged and the intact vessel is driven by three parameters: the vertical wave bending moment, the ultimate vertical bending moment capacity and the modelling uncertainty factor of the vertical wave bending moment. In both the damaged and the intact vessel the vertical wave bending moment is always the dominant random variable that drives the failure. This is followed by the ultimate vertical bending moment capacity in the damaged case and by the modelling uncertainty factor of the vertical wave bending moment in the intact case. When the assessment is studied using the linear limit state function, the failure of the damaged and the intact vessel is govern by four parameters: the vertical wave bending moment, the modelling uncertainty factor of the ultimate vertical bending moment capacity, the ultimate vertical bending moment capacity and the modelling uncertainty factor of the vertical wave bending moment. In both the damaged and the intact vessel the vertical wave bending moment is again the dominant random variable responsible for failure. This is closely followed by the modelling uncertainty factor of the ultimate vertical bending moment capacity. The third most important random variable that drives the failure for the damaged vessel is the ultimate bending moment capacity of the damage vessel while the third most important random variable for the intact case is the modelling uncertainty factor of the vertical wave bending moment.

The horizontal components of the loads and the capacities are not affecting the results of the reliability assessment primarily because there are limitations in the tools used to estimate the wave loads on the damaged ship. This situation will be remedied in future study by using loading scenarios that more realistic account for horizontal wave loads during gross damage.

### **5.3 Recommendations**

The following tasks are recommended for future work:

- Reassess the structural integrity of the intact and the damaged ex-HMCS Nipigon ship using more realistic operation profile for the intact ship and the damaged vessel. Current limitation in WAVELOAD did not allow for adequate modelling of the damage ship. This will be remedied in the next study.
- Assessment of the structural integrity of the intact and the damaged ship using other cross-sections of the vessel. The current study was limited to only the midship due to budgetary concerns, even though other sections were identified for analysis.
- Assessment of the structural integrity of the intact and the damaged ship using analytical formulas suggested by classification societies for loads and strength. This will allow for a comparison between the current results and the suggested solutions by these societies.
- Execute the structural integrity of the damaged vessel with inclusion of other damage modes such as torsion, vertical and horizontal shear forces.
- Assessment of the structural integrity of the intact and the damaged ship using a more robust representation of the ultimate strength such as finite element method.
- Define other gross damage locations and sizes and study sensitivities of structural integrity due to the extent of damage and its location.
- Perform sensitivity study of reliability of the damaged ship due to the variation in the selected extreme loads. The current study used all the value of the extreme loads that were generated even though some of these extreme loads have very small values compared to others. It will be worthwhile to perform sensitivity study by limiting the analysis to certain threshold values of the extreme wave loads.

The items suggested above can be investigated independently or in any combination that DRDC wants. Although the tasks are suggested for the current ex-HMCS Nipigon vessel, they can also be applied to any other vessel that is of interest to DRDC.

## References

---

Smith M. J., (2008), Ultimate strength assessment of naval and commercial ships Defence R&D Canada – Atlantic, DRDC Atlantic TR 2008-059, August 2008.

TRIDENT FEA 2004 User's Manual, (2004), SM-04-06. Martec Limited. Halifax, Nova Scotia.

Akpan, U.O, T.S. Koko, B.K. Yuen and K.O. Shahin, (2010), Probability of Failure of Damaged Ship Structures: Phase 1, TR-10-16, Martec Limited. Halifax, NS.

Akpan, U.O, B.K. Yuen and K.O. Shahin , T.S. Koko, and F. Lin, (2012), Probability of Failure of Damaged Ship Structures: Phase II, DRDC Atlantic CR 2012-010.

## Annex A Summary of the Importance Factors of the Random Variable Used in the Intact Ship Reliability Analysis

---

*Table 31 Summaries of Importance Factors of the Random Variable Used In the Interaction Equation Limit State Model for the Intact Ship –IACS Model*

Quadrant and Speed	Random Variable with Highest Importance Factor - Vertical Wave Bending Moment	Random Variable with 2 <sup>nd</sup> Highest Importance Factor - Mod. Uncertainty Vertical Wave Bending Moment	Random Variable with 3 <sup>rd</sup> Highest Importance Factor Ultimate Vertical Bending Moment
Quadrant 1: 3 and 6 knots	79%	16%	5%
Quadrant 4: 3 and 6 knots	73%	20%	7%
Quadrant 3: 3 and 6 knots	79%	16%	5%
Quadrant 2: 3 and 6 knots	73%	20%	7%
Quadrant 1: 6 and 9 knots	80%	15%	5%
Quadrant 4: 6 and 9 knots	77%	17%	6%
Quadrant 3: 6 and 9 knots	81%	15%	4%
Quadrant 2: 6 and 9 knots	74%	19%	7%
Quadrant 1: 9 and 12 knots	82%	14%	4%
Quadrant 4: 9 and 12 knots	77%	17%	6%
Quadrant 3: 9 and 12 knots	82%	14%	4%
Quadrant 2: 9 and 12 knots	75%	19%	6%

Table 32 Summaries of Importance Factors of the Random Variable Used In the Linear Equation Limit State Model for the Intact Ship –IACS Model

Quadrant and Speed	Random Variable with Highest Importance Factor - Vertical Wave Bending Moment	Random Variable with 2 <sup>nd</sup> Highest Importance Factor - Mod. Uncertainty Ultimate Vertical Bending Moment	Random Variable with 3 <sup>rd</sup> Highest Importance Factor Mod. Uncertainty Vertical Wave Bending Moment	Random Variable with 4th Highest Importance Factor Ultimate Vertical Bending Moment
Quadrant 1: 3 and 6 knots	61%	26%	10%	3%
Quadrant 4: 3 and 6 knots	52%	35%	10%	3%
Quadrant 3: 3 and 6 knots	61%	26%	10%	3%
Quadrant 2: 3 and 6 knots	51%	36%	10%	3%
Quadrant 1: 6 and 9 knots	64%	24%	9%	3%
Quadrant 4: 6 and 9 knots	52%	35%	10%	3%
Quadrant 3: 6 and 9 knots	65%	23%	9%	3%
Quadrant 2: 6 and 9 knots	54%	33%	10%	3%
Quadrant 1: 9 and 12 knots	66%	22%	9%	3%
Quadrant 4: 9 and 12 knots	57%	30%	10%	3%
Quadrant 3: 9 and 12 knots	66%	22%	9%	3%
Quadrant 2: 9 and 12 knots	56%	31%	10%	3%

*Table 33 Summaries of Importance Factors of the Random Variable Used In the Interaction Equation Limit State Model for the Intact Ship –FE Calibrated Model*

<b>Quadrant and Speed</b>	<b>Random Variable with Highest Importance Factor - Vertical Wave Bending Moment</b>	<b>Random Variable with 2<sup>nd</sup> Highest Importance Factor - Mod. Uncertainty Vertical Wave Bending Moment</b>	<b>Random Variable with 3<sup>rd</sup> Highest Importance Factor Ultimate Vertical Bending Moment</b>
Quadrant 1: 3 and 6 knots	79%	14%	7%
Quadrant 4: 3 and 6 knots	74%	16%	10%
Quadrant 3: 3 and 6 knots	79%	14%	7%
Quadrant 2: 3 and 6 knots	72%	18%	10%
Quadrant 1: 6 and 9 knots	82%	14%	4%
Quadrant 4: 6 and 9 knots	79%	16%	5%
Quadrant 3: 6 and 9 knots	83%	13%	4%
Quadrant 2: 6 and 9 knots	76%	18%	6%
Quadrant 1: 9 and 12 knots	83%	13%	4%
Quadrant 4: 9 and 12 knots	79%	16%	5%
Quadrant 3: 9 and 12 knots	83%	13%	4%
Quadrant 2: 9 and 12 knots	78%	17%	5%

*Table 34 Summaries of Importance Factors of the Random Variable Used In the Linear Equation Limit State Model for the Intact Ship –FE Calibrated Model*

<b>Quadrant and Speed</b>	<b>Random Variable with Highest Importance Factor - Vertical Wave Bending Moment</b>	<b>Random Variable with 2<sup>nd</sup> Highest Importance Factor - Mod. Uncertainty Ultimate Vertical Bending Moment</b>	<b>Random Variable with 3<sup>rd</sup> Highest Importance Factor Mod. Uncertainty Vertical Wave Bending Moment</b>	<b>Random Variable with 4th Highest Importance Factor Ultimate Vertical Bending Moment</b>
Quadrant 1: 3 and 6 knots	62%	24%	9%	5%
Quadrant 4: 3 and 6 knots	55%	30%	10%	5%
Quadrant 3: 3 and 6 knots	62%	24%	9%	5%
Quadrant 2: 3 and 6 knots	54%	31%	10%	5%
Quadrant 1: 6 and 9 knots	66%	22%	9%	3%
Quadrant 4: 6 and 9 knots	59%	28%	10%	3%
Quadrant 3: 6 and 9 knots	66%	22%	9%	3%
Quadrant 2: 6 and 9 knots	58%	29%	10%	3%
Quadrant 1: 9 and 12 knots	68%	20%	9%	3%
Quadrant 4: 9 and 12 knots	60%	27%	10%	3%
Quadrant 3: 9 and 12 knots	67%	21%	9%	3%
Quadrant 2: 9 and 12 knots	60%	27%	10%	3%

## Annex B Summary of the Importance Factors of the Random Variable Used in the Damaged Ship Reliability Analysis

---

*Table 35 Summaries of Importance Factors of the Random Variable Used In the Interaction Equation Limit State Model for the Damaged Ship –IACS Model*

<b>Quadrant and Speed</b>	<b>Random Variable with Highest Importance Factor - Vertical Wave Bending Moment</b>	<b>Random Variable with 2<sup>nd</sup> Highest Importance Factor Ultimate Vertical Bending Moment of Damaged Ship</b>	<b>Random Variable with 3<sup>rd</sup> Highest Importance Factor Mod. Uncertainty Vertical Wave Bending Moment</b>
Quadrant 1: 3 and 6 knots	65%	24%	11%
Quadrant 4: 3 and 6 knots	56%	33%	11%
Quadrant 3: 3 and 6 knots	71%	16%	13%
Quadrant 2: 3 and 6 knots	59%	28%	13%
Quadrant 1: 6 and 9 knots	69%	21%	10%
Quadrant 4: 6 and 9 knots	59%	29%	12%
Quadrant 3: 6 and 9 knots	67%	22%	11%
Quadrant 2: 6 and 9 knots	57%	31%	12%
Quadrant 1: 9 and 12 knots	70%	20%	10%
Quadrant 4: 9 and 12 knots	61%	28%	11%
Quadrant 3: 9 and 12 knots	75%	13%	12%
Quadrant 2: 9 and 12 knots	66%	19%	15%

*Table 36 Summaries of Importance Factors of the Random Variable Used In the Linear Equation Limit State Model for the Damaged Ship –IACS Model*

<b>Quadrant and Speed</b>	<b>Random Variable with Highest Importance Factor - Vertical Wave Bending Moment</b>	<b>Random Variable with 2<sup>nd</sup> Highest Importance Factor - Mod. Uncertainty Ultimate vertical Bending Moment</b>	<b>Random Variable with 3<sup>rd</sup> Highest Importance Factor Ultimate Vertical Bending Moment of Damaged Ship</b>	<b>Random Variable with 4th Highest Importance Factor Mod. Uncertainty Vertical Wave Bending Moment</b>
Quadrant 1: 3 and 6 knots	55%	21%	16%	8%
Quadrant 4: 3 and 6 knots	48%	26%	18%	8%
Quadrant 3: 3 and 6 knots	54%	23%	15%	8%
Quadrant 2: 3 and 6 knots	48%	30%	14%	8%
Quadrant 1: 6 and 9 knots	59%	19%	14%	8%
Quadrant 4: 6 and 9 knots	51%	24%	17%	8%
Quadrant 3: 6 and 9 knots	57%	20%	15%	8%
Quadrant 2: 6 and 9 knots	49%	25%	18%	8%
Quadrant 1: 9 and 12 knots	60%	18%	14%	8%
Quadrant 4: 9 and 12 knots	52%	23%	17%	8%
Quadrant 3: 9 and 12 knots	62%	21%	9%	8%
Quadrant 2: 9 and 12 knots	53%	28%	10%	9%

*Table 37 Summaries of Importance Factors of the Random Variable Used In the Interaction Equation Limit State Model for the Damaged Ship –FE Calibrated Model*

<b>Quadrant and Speed</b>	<b>Random Variable with Highest Importance Factor - Vertical Wave Bending Moment</b>	<b>Random Variable with 2<sup>nd</sup> Highest Importance Factor Ultimate Vertical Bending Moment of Damaged Ship</b>	<b>Random Variable with 3<sup>rd</sup> Highest Importance Factor Mod. Uncertainty Vertical Wave Bending Moment</b>
Quadrant 1: 3 and 6 knots	71%	18%	11%
Quadrant 4: 3 and 6 knots	63%	24%	13%
Quadrant 3: 3 and 6 knots	70%	18%	12%
Quadrant 2: 3 and 6 knots	69%	16%	15%
Quadrant 1: 6 and 9 knots	73%	16%	11%
Quadrant 4: 6 and 9 knots	66%	21%	13%
Quadrant 3: 6 and 9 knots	75%	13%	12%
Quadrant 2: 6 and 9 knots	68%	18%	14%
Quadrant 1: 9 and 12 knots	75%	15%	10%
Quadrant 4: 9 and 12 knots	68%	20%	12%
Quadrant 3: 9 and 12 knots	74%	15%	11%
Quadrant 2: 9 and 12 knots	66%	21%	13%

Table 38 Summaries of the Importance Factors of the Random Variables Used In the Linear Equation Limit State Model for the Damaged Ship –FE Calibrated Model

Quadrant and Speed	Random Variable with Highest Importance Factor - Vertical Wave Bending Moment	Random Variable with 2 <sup>nd</sup> Highest Importance Factor - Mod. Uncertainty Ultimate Vertical Bending Moment	Random Variable with 3 <sup>rd</sup> Highest Importance Factor Ultimate Vertical Bending Moment of Damaged Ship	Random Variable with 4th Highest Importance Factor Mod. Uncertainty Vertical Wave Bending Moment
Quadrant 1: 3 and 6 knots	59%	21%	12%	8%
Quadrant 4: 3 and 6 knots	51%	26%	14%	9%
Quadrant 3: 3 and 6 knots	59%	21%	12%	8%
Quadrant 2: 3 and 6 knots	52%	32%	7%*	9% **
Quadrant 1: 6 and 9 knots	62%	19%	11%	8%
Quadrant 4: 6 and 9 knots	54%	24%	13%	9%
Quadrant 3: 6 and 9 knots	63%	20%	9%	8%
Quadrant 2: 6 and 9 knots	54%	27%	10%	9%
Quadrant 1: 9 and 12 knots	64%	18%	10%	8%
Quadrant 4: 9 and 12 knots	57%	23%	12%	8%
Quadrant 3: 9 and 12 knots	63%	18%	11%	8%
Quadrant 2: 9 and 12 knots	54%	24%	13%	9%