

FINAL REPORT – PILOT SCALE

Demonstration of Regenerable, Large-scale Ion Exchange
System Using WBA Resin in Rialto, CA

ESTCP Project ER-201168

March 2008

Jeffrey Rine
Edward Coppola
Andrea Davis
Applied Research Associates, Inc.

This document has been cleared for public release



Report Documentation Page

Form Approved
OMB No. 0704-0188

Public reporting burden for the collection of information is estimated to average 1 hour per response, including the time for reviewing instructions, searching existing data sources, gathering and maintaining the data needed, and completing and reviewing the collection of information. Send comments regarding this burden estimate or any other aspect of this collection of information, including suggestions for reducing this burden, to Washington Headquarters Services, Directorate for Information Operations and Reports, 1215 Jefferson Davis Highway, Suite 1204, Arlington VA 22202-4302. Respondents should be aware that notwithstanding any other provision of law, no person shall be subject to a penalty for failing to comply with a collection of information if it does not display a currently valid OMB control number.

1. REPORT DATE MAR 2008	2. REPORT TYPE	3. DATES COVERED 00-00-2008 to 00-00-2008			
4. TITLE AND SUBTITLE Demonstration of Regenerable, Large-scale Ion Exchange System Using WBA Resin in Rialto, CA		5a. CONTRACT NUMBER			
		5b. GRANT NUMBER			
		5c. PROGRAM ELEMENT NUMBER			
6. AUTHOR(S)		5d. PROJECT NUMBER			
		5e. TASK NUMBER			
		5f. WORK UNIT NUMBER			
7. PERFORMING ORGANIZATION NAME(S) AND ADDRESS(ES) Applied Research Associates, Inc., 4300 San Mateo Blvd. NE, Suite A-220, Albuquerque, NM, 87110		8. PERFORMING ORGANIZATION REPORT NUMBER			
9. SPONSORING/MONITORING AGENCY NAME(S) AND ADDRESS(ES)		10. SPONSOR/MONITOR'S ACRONYM(S)			
		11. SPONSOR/MONITOR'S REPORT NUMBER(S)			
12. DISTRIBUTION/AVAILABILITY STATEMENT Approved for public release; distribution unlimited					
13. SUPPLEMENTARY NOTES					
14. ABSTRACT					
15. SUBJECT TERMS					
16. SECURITY CLASSIFICATION OF:			17. LIMITATION OF ABSTRACT Same as Report (SAR)	18. NUMBER OF PAGES 160	19a. NAME OF RESPONSIBLE PERSON
a. REPORT unclassified	b. ABSTRACT unclassified	c. THIS PAGE unclassified			

Table of Contents

Table of Contents	ii
List of Figures.....	iv
List of Tables	v
Acronyms	vi
Executive Summary	vii
1.0 Introduction.....	1
1.1 Background.....	1
1.2 Objectives of the Demonstration	1
1.3 Regulatory Drivers.....	2
1.4 Stakeholder/End-User Issues	2
2.0 Technology Description	3
2.1 Technology Development and Application	3
2.2 Previous Testing of the Technology	6
2.3 Factors Affecting Cost and Performance.....	6
2.4 Advantages and Limitations of the Technology	7
3.0 Demonstration Design	8
3.1 Performance Objectives.....	8
3.1.1 System Operability.....	9
3.1.2 System Reliability	9
3.1.3 System Scalability	9
3.1.4 Meet Regulatory Standards	9
3.1.5 Capacity – Bed Volumes Treated.....	10
3.1.6 Post Treatment “Dial In” Capability	11
3.1.7 Resin Regeneration	12
3.1.8 Process Waste.....	12
3.1.9 O&M Treatment Cost	13
3.1.10 Treating Spent Regenerant	13
3.1.11 Resin Capacity following Regeneration.....	13
3.1.12 Treatment Flowrate	14

3.2 Selecting Test Site(s).....	14
3.3 Test Site Description	14
3.4 Pre-Demonstration Testing and Analysis	14
3.5 Testing and Evaluation Plan	15
3.5.1 Demonstration Installation and Start-Up.....	15
3.5.2 Period of Operation	17
3.5.3 Amount /Treatment Rate of Material to be Treated.....	18
3.5.4. Residuals Handling	18
3.5.5 Operating Parameters for the Technology	19
3.5.6 Experimental Design.....	19
3.5.7 Sampling Plan	22
3.5.8 Demobilization.....	27
3.6 Selection of Analytical/Testing Methods	27
3.7 Selection of Analytical/Testing Laboratory.....	28
4.0 Performance Assessment.....	29
4.1 Performance Criteria.....	29
4.2 Performance Confirmation Methods	29
4.3 Data Analysis, Interpretation and Evaluation.....	32
5.0 Cost Assessment	33
5.1 Cost Reporting.....	33
5.1.1 Capital Cost.....	33
5.1.1.1 Process Configuration.....	33
5.1.1.2 Design and Operating Basis.....	35
5.1.1.3 Major Equipment	36
5.1.2 Operating and Maintenance Cost	37
5.1.2.1 Primary O&M Cost Components.....	37
5.1.2.2 O&M Cost Basis.....	38
5.1.3 Economy of Scale.....	40
5.2 Cost Analysis	41
5.2.1 Major Cost Drivers.....	41
5.2.1.1 Groundwater Alkalinity	41

5.2.1.2 Perchlorate Concentration.....	41
5.2.1.3 Treated Water Alkalinity	41
5.2.1.4 Resin Regeneration Cost.....	42
5.2.1.5 WBA Resin Cost.....	42
5.3 Cost Comparison	42
6.0 Implementation Issues	44
6.1 Environmental Checklist	44
6.2 Other Regulatory Issues.....	44
6.3 End-User Issues	44
6.4 Lessons Learned	45
7.0 References	46
8.0 Points of Contact.....	47
Appendix A. Site Map of Plant Site F17- Fontana, CA	
Appendix B. Quality Assurance Program Plan used during Demonstration	
Appendix C. Summary of Analytical Data	
Appendix D. Cost Analysis of Strong Base Anion Resins for Selecting Scavenger Resin	
Appendix E. Health and Safety Plan	

List of Figures

Figure 2-1. Weak Base Anion Resin Chemistry.....	3
Figure 2-2. Demonstration Process Flow Diagram.....	4
Figure 3-1. Comparison of WBA Resin Adsorption Capacity for Test Periods 1, 2, 5, & 6.....	10
Figure 3-2. Duration of each Test Period.....	18
Figure 3-3. Batch Regeneration	21
Figure 3-4. Scavenger Apparatus.....	21
Figure 3-5. Pilot System Process Schematic with Sampling Locations	22
Figure 5-1. Process Configuration for Capital and O&M Cost Analyses.....	33
Figure 5-2. Regeneration Operations.....	34
Figure 5-3. Protonation Operations.....	35

List of Tables

Table 3-1. Performance Objectives.....	8
Table 3-2. Perchlorate Concentration of the Treated Water at the End of each Test Period.....	9
Table 3-3. Post Treatment Water Quality.....	11
Table 3-4. Perchlorate Concentration in Treated Water of Freshly Regenerated Column.....	12
Table 3-5. Regeneration Efficiency for WBA Resin Technology	12
Table 3-6. Anion Concentrations in Spent Regenerant Before and After Scavenging Treatment.....	13
Table 3-7. – Pre-Demonstration Water Quality for Well F17C.....	15
Table 3-8. Amount of Water Treated	18
Table 3-9. Test Matrix.....	20
Table 3-10. Sampling Summary during Test Periods 1 & 2.....	23
Table 3-11. Sampling Summary during Test Periods 3 & 4.....	24
Table 3-12. Sampling Summary during Test Periods 5 & 6.....	25
Table 3-13. Sampling Summary for Regeneration and Residual Treatments	26
Table 3-14. Analysis Parameters.....	26
Table 3-15. Analytical Procedures for the Proposed Study.....	27
Table 4-1. Performance Criteria.....	29
Table 4-2. Expected Performance and Performance Confirmation Methods	30
Table 4.3. Number of Split Samples Analyzed for Perchlorate.....	32
Table 5-1. Summary of Design and Operating Bases	36
Table 5-2. Type and Quantity of WBA System Equipment, and 2007 Budgetary Cost Estimates ...	37
Table 5-3. O&M Cost Basis	39
Table 5-4. Cost Summary	40
Table 5-5. Capital and Operating Costs for a 4,000 gpm Treatment System	41
Table 5-6. Present Worth Cost Comparison for Perchlorate Removal	43

Abbreviations and Acronyms

A&E – Architecture and Engineering	NaOH – Sodium hydroxide
AF – Acre Feet	NDBA – N-nitrosodi-n-butylamine
AFB – Air Force Base	NDEA – N-nitrosodiethylamine
ARA – Applied Research Associates, Inc.	NDMA – N-nitrosodimethylamine
	NDPA – N-nitrosodi-n-propylamine
BV – Bed volumes	NMEA – N-nitrosomethylethylamine
BV/hr – Bed volumes per hour	NMOR – N-nitrosomorpholine
	NPDES – National Pollutant Discharge Elimination System
CaCO ₃ – Calcium carbonate	NPIP – N-nitrosopiperidine
ClO ₄ ⁻ – Perchlorate	NPYR – N-nitrosopyrrolidine
CCAL – Continuing Calibration Check Standard	NSF – National Sanitation Foundation
CDPH – California Department of Public Health	O&M – Operation and Maintenance
CSTR – Continuously Stirred Tank Reactor	OSHA – Occupational Safety and Health Administration
DOD – Department of Defense	PHG – Public Health Goal
DWEL – Drinking Water Equivalent Level	ppb – parts per billion
	PPE – Personal Protective Equipment
EPA – Environmental Protection Agency	ppm – parts per million
ESTCP – Environmental Strategic Technology Certification Program	ppt – parts per trillion
	psig – pounds per square inch, gauge
gpm – gallons per minute	
	QA – Quality Assurance
HASP–Health and Safety Plan	QA/QC – Quality Assurance/Quality Control
HCl – Hydrochloric acid	QAPP – Quality Assurance Project Plan
HCO ₃ – Bicarbonate	
H ₂ SO ₄ – Sulfuric acid	
	RfD – Reference Dose
IC – Ion Chromatography	RPD – Relative Percent Difference
IC/MS – Ion Chromatography/Mass Spectrometry	
I&C – Instrumentation and Control	SBA – Strong Base Anion
ISEP – Ion Separation	SSC – Site Safety Coordinator
IX – Ion Exchange	
	TCE – Trichloroethylene
L - Liters	TPM – Technical Program Manager
LSI – Langelier Saturation Index	
	VOC – Volatile Organic Carbon
MCL – Maximum Contaminant Level	
	WBA – Weak Base Anion

Executive Summary

Introduction

The Department of Defense (DOD) has used perchlorate (ClO_4^-) as an oxidizer in ordnance items and rocket motors for over half a century. This very water soluble and environmentally persistent compound now contaminates drinking water for tens of millions of people in the United States. In 2002, the U.S. Environmental Protection Agency released a provisional perchlorate Oral Reference Dose (RfD), which translated into a drinking water equivalent level of 1 part per billion (ppb). This drinking water equivalent level (DWEL) was increased to 24.5 ppb following the release of a report by the National Academy of Science in 2005.

As a result of EPA establishing a reference dose for perchlorate having a DWEL of 24.5 ppb, the DOD issued a policy letter in January 2006 that establishes 24 ppb as the “level of concern for managing perchlorate.” The letter further states that, “Once established, DOD will comply with applicable state or federal promulgated standards whichever is more stringent.” The letter also provides guidance for perchlorate with respect to sampling and analysis, record keeping, environmental restoration, operational ranges, drinking water systems, and wastewater discharges. These guidance letters will impact many end-users and stakeholders. Some of the issues that these end-users and stakeholders face using ion exchange technologies include a simple and effective regeneration process, disposal of concentrated regenerant streams, and cost.

In California, the proposed maximum contaminant level (MCL) for perchlorate is 6 ppb. The cost for DOD to achieve compliance with this drinking water limit could be billions of dollars. The current approach is treatment by either ion exchange or biological processes. The ion exchange approach is favored for drinking water applications. Existing ion exchange technologies in use today include regenerable and single-use processes. Regenerable ion exchange processes use salt as the regenerating agent, such as the Calgon ISEP[®] process and other, more conventional, lead-lag processes. These non-selective regenerable systems require frequent regeneration and generate large volumes of salt brine containing high concentrations of nitrate, sulfate and perchlorate. This waste stream is becoming more difficult to dispose and the operation and maintenance (O&M) cost from frequent regenerations is high. Single-use ion exchange processes use strong base anion resins. After perchlorate loading capacity is reached, the single-use resins must be removed from the ion exchange vessels and incinerated resulting in high disposal and replacement costs.

Background – Demonstration at Redstone Arsenal

In 2005, ESTCP funded Applied Research Associates, Inc (ARA) to demonstrate a regenerable, ion exchange technology, co-developed with The Purolite Company, using weak base anion (WBA) resin (D-4170) in a groundwater remediation application. The demonstration was conducted at Redstone Arsenal, located near Huntsville, AL. Well RS498, a six-inch extraction well, was selected as the groundwater source for the demonstration. Anion concentrations of the well were as follows: 1,500 to 2,200 ppb perchlorate; 4 ppm nitrate; 3 ppm sulfate; 4 ppm chloride; and 190 ppm bicarbonate. Trichloroethylene was also present in the groundwater at 3,100 ppb. During the fifteen week demonstration, the process successfully removed perchlorate

to below the method detection limit (4 ppb) using EPA Method 314.0. Regeneration was effectively and efficiently accomplished resulting in less than 0.05% spent regenerant volume based on the water treated. The spent regenerant solution consisted of a relatively safe caustic solution that could be treated for perchlorate by scavenging using a strong base anion resin or by biodegrading after pH adjustment.

Demonstration – Drinking Water Application

Based upon the successful demonstration at Redstone Arsenal, ESTCP funded a follow-on demonstration of the WBA ion exchange technology for a drinking water application. The demonstration had the following objectives: 1) demonstrate complete perchlorate removal, 2) demonstrate efficient and complete WBA resin regeneration, 3) demonstrate a “zero-discharge” perchlorate scavenger process, and 4) produce treated water that meets all drinking water quality guidelines. The demonstration was conducted at Plant F17 in Fontana, CA. Well F17-C water contained 8 ppb perchlorate; 11 ppm chloride; 31 ppm nitrate; 14 ppm sulfate; and 150 ppm bicarbonate.

The ion exchange pilot treatment system used during the demonstration at Redstone Arsenal (Project No. CU-0312) was modified for use in this drinking water demonstration. Modifications included fabrication and installation of: 1) column feed and effluent manifolds for flow flexibility, 2) a regeneration and protonation system for on-site regeneration, 3) a scavenger resin system to treat spent regenerating solution onsite, 4) a manifold and flow control system for the post treatment process, 5) a carbon dioxide stripping column and Liqui-Cel membrane, and 6) a calcite contacting column. The entire system was housed in an eight foot by twenty foot enclosed trailer that provided breakered power, climate control, and protection from the elements while in the field. Ion exchange columns were prepared at the ARA Panama City Research Facility using Purolite D-4170 resin from the same batch of resin used in the demonstration at Redstone Arsenal.

Summary of Demonstration Results

Six test periods were conducted during this demonstration. Four test periods (1, 2, 5, and 6) were breakthrough tests with a treatment rate of 3 gpm/ft³ (a surface loading rate of 9.7 gpm/ft²). The remaining two test periods (3 and 4) were short-cycle tests. In the short-cycle tests, columns were regenerated after approximately one week on-line and before perchlorate breakthrough. These short-cycle tests were conducted to maximize the number of regenerations per column and minimize the duration of the demonstration. The short-cycle tests were also used to evaluate perchlorate removal efficiency at a higher specific flow rate of 4 gpm/ft³ (a surface loading rate of 12.9 gpm/ft²).

The treated water was below the method report limit for perchlorate (<0.10 ppb) using IC/MS/MS. Nitrosamines were analyzed using EPA Method 521. NDMA was 2.6 ppt with a detection limit of 2 ppt. All other nitrosamines analyzed (including NDEA, NDBA, NDPA, NMEA, NMOR, NPIP, and NPYR) were below the detection limit. A “dial in” capability for controlling residual alkalinity of the treated water in the post treatment process was demonstrated by varying the pH and using a combination of air/membrane stripping and calcite contacting.

Treated water had a Langelier Saturation Index (LSI) near zero, which indicated that it had neither corrosive nor scaling tendencies.

The treatment capacity determined from this demonstration was 9,700 bed volumes. This treatment capacity is lower than predicted due to higher nitrate concentration in the groundwater than anticipated (33 ppm as nitrate as opposed to 4 ppm as nitrate) and to lower perchlorate concentration than anticipated (approximately 6 ppb as opposed to 14 ppb). The lower treatment capacity demonstrated due to these concentrations is consistent with the prediction model used to estimate treatment capacity.

Regeneration of spent resin and was conducted on-site. Five resin regenerations were accomplished using approximately three bed volumes of regenerant solution, or less than 0.05% of the treated water. The spent regenerating solution was successfully treated using a scavenger resin approach to remove perchlorate to below the method reporting limit.

End-users

End-users for this technology include DOD facilities, formerly-used defense sites, and municipal drinking water systems that have been contaminated with perchlorate. In addition to drinking water applications, the technology can be used by the DOD for pump-and-treat perchlorate remediation and to facilitate remediation of co-contaminants (such as VOCs) by enabling the removal of perchlorate before discharge or re-injection. The technology can also be applied to the treatment of wastewater generated by munitions manufacturing or demilitarization operations.

Implementation of this technology is straightforward. Commercial, large-scale, ion exchange equipment for WBA resin technology exists. Pretreatment and post treatment are simply pH-controlled unit operations that are straight forward to design and engineer. Stripping tower design and engineering for CO₂ stripping is straight forward. Treatment of residuals by a scavenger ion exchange process is a proven technology. All processes operate at ambient temperature and low pressure (<~30 psig) and, therefore, present no unique engineering challenges or hazards.

The regenerable nature of this ion exchange technology is by definition more complex than single-use resin technology, will require use of regeneration chemicals on site, and will require an operator. Therefore, the issues of primary concern for user acceptance are; 1) the perception of operational complexity, 2) the need for acid and caustic on site, and 3) the need for a part-time operator. However, treatment systems can be designed to operate with little operator oversight. For instance, regeneration cycles can be automatically initiated and executed. End user concerns may be further offset by applications where water is highly contaminated, where regenerable ion exchange technologies are already in use, or where co-contaminants, such as nitrate, arsenic, or chromium, create the need for a regenerable ion exchange process.

Cost

The WBA resin technology overcomes issues typically associated with regenerable ion exchange processes by greatly reducing the volume of spent regenerating solution produced, which permits use of the zero-discharge perchlorate scavenging process and results in lower operating and

maintenance (O&M) costs. The scavenger approach costs less than \$5 per acre-foot to implement based on conditions at the Fontana demonstration site. Use of the WBA resin ion exchange process for treating perchlorate has proven efficient and economical, resulting in a 75% savings over current regenerable resin technology such as the ISEP process and up to a 50% savings over single-use resin processes. Treatment cost using the WBA resin process is less than \$100 per acre-foot. Groundwater alkalinity, sulfate and nitrate concentration, and the treated water alkalinity required will affect performance and cost, as is the case for any ion exchange process. However, the cost advantage of the WBA regenerable process over non-regenerable, single-use processes becomes much more pronounced as perchlorate concentrations increase.

Summary of Demonstration Results

Six test periods were conducted during this demonstration. Four test periods (1, 2, 5, and 6) were breakthrough tests with a treatment rate of 3 gpm/ft³ (a surface loading rate of 9.7 gpm/ft²). The remaining two test periods (3 and 4) were short-cycle tests. In the short-cycle tests, columns were regenerated after approximately one week on-line and before perchlorate breakthrough. These short-cycle tests were conducted to maximize the number of regenerations per column and minimize the duration of the demonstration. The short-cycle tests were also used to evaluate perchlorate removal efficiency at a higher specific flow rate of 4 gpm/ft³ (a surface loading rate of 12.9 gpm/ft²).

The treated water was below the method report limit for perchlorate (<0.10 ppb) using IC/MS/MS. Nitrosamines were analyzed using EPA Method 521. NDMA was 2.6 ppt with a detection limit of 2 ppt. All other nitrosamines analyzed (including NDEA, NDBA, NDPA, NMEA, NMOR, NPIP, and NPYR) were below the detection limit. A “dial in” capability for controlling residual alkalinity of the treated water in the post treatment process was demonstrated by varying the pH and using a combination of air/membrane stripping and calcite contacting. Treated water had a Langelier Saturation Index (LSI) near zero, which indicated that it had neither corrosive nor scaling tendencies.

The treatment capacity determined from this demonstration was 9,700 bed volumes. This treatment capacity is lower than predicted due to higher nitrate concentration in the groundwater than anticipated (33 ppm as nitrate as opposed to 4 ppm as nitrate). The lower treatment capacity was consistent with the model prediction.

Regeneration of spent resin and was conducted on-site. Five resin regenerations were accomplished using approximately three bed volumes of regenerant solution, or less than 0.05% of the treated water. The spent regenerating solution was successfully treated using a scavenger resin approach to remove perchlorate to below the reporting limit of the analytical method.

1. Introduction

1.1 Background

The Department of Defense (DOD) has used perchlorate (ClO_4^-) as an oxidizer in ordnance items and rocket motors for over half a century. This very water soluble and environmentally persistent compound now contaminates drinking water for tens of millions of people in the United States. In 2002, the United States Environmental Protection Agency (EPA) released a provisional perchlorate oral reference dose (RfD), which translated into a drinking water equivalent level of 1 part per billion (ppb). This drinking water equivalent level was increased to 24.5 ppb following the release of a report by the National Academy of Science. On January 26, 2006, a policy on DOD required actions related to perchlorate was released by the Office of the Under Secretary of Defense establishing 24 ppb as the current level of concern for managing perchlorate. The State of California has a proposed maximum contaminant level (MCL) of 6 ppb.

The cost for DOD to achieve compliance with these drinking water limits has been estimated to be in the billions of dollars. The current approach is treatment by either ion exchange or biological processes. The ion exchange approach is favored for groundwater and drinking water applications. Existing ion exchange technologies in use today include regenerable ion exchange processes that use salt as the regenerating agent, such as the Calgon ISEP[®] process and other, more conventional lead-lag processes. The non-selective regenerable systems require frequent regeneration and generate large volumes of salt brine containing high concentrations of nitrate, sulfate and perchlorate. The operation and maintenance (O&M) cost from frequent regenerations is high. In addition, the waste stream generated is becoming more difficult to dispose. Existing ion exchange technologies also include single-use ion exchange processes that use strong base anion resins. After perchlorate loading capacity is reached, the single-use resins must be removed from the ion exchange vessels and incinerated resulting in high disposal and replacement costs. The work proposed for this demonstration builds upon past research that has been performed to address the problems with current ion exchange technologies. The goal is to demonstrate a more efficient and economical approach for removing perchlorate from groundwater and drinking water.

1.2 Objectives of the Demonstration

The demonstration conducted at Redstone Arsenal confirmed that the weak base anion (WBA) resin technology developed by Applied Research Associates, Inc. (ARA) and Purolite performs very well for perchlorate removal and has the potential to reduce O&M cost to less than 50% of the most efficient ion exchange processes available. Based on the success of the demonstration at Redstone Arsenal, the primary objectives of a second demonstration using WBA resin technology were to:

- Demonstrate the WBA resin technology for drinking water treatment in California
- Demonstrate “zero-discharge,” scavenger resin approach for treating spent regenerating solutions
- Coordinate with California Department of Public Health (CDPH), Drinking Water Field Operations Branch, to acquire a letter of conditional acceptance and acquire CDPH

approval for this WBA resin ion exchange treatment process in drinking water applications

Perchlorate-selective as well as non-selective ion exchange resins are currently used commercially for perchlorate removal from drinking water in California. However, current ion exchange processes that use strong base anion exchange resins have several liabilities. These liabilities include: 1) the high cost of resin replacement and incineration for non-regenerable (single-use), perchlorate-specific ion exchange systems; 2) large volume of contaminated brine residual generated by non-specific perchlorate regenerable systems; and 3) the difficulty and high cost of treating residuals. The technology proposed for this demonstration takes advantage of the performance of a regenerable, perchlorate-selective resin and addresses the liabilities associated with existing, single-use and brine-regenerable ion exchange processes.

To achieve the project objectives, a demonstration of ARA's WBA resin ion exchange technology was conducted at Fontana Water located in San Bernardino County, CA. Drinking water well F17C served as the source water for this demonstration and had a perchlorate contamination of approximately 6 ppb. The Fontana Water Company assisted ARA by providing water quality characteristics and site support.

1.3 Regulatory Drivers

There are many regulatory drivers for perchlorate. On January 26, 2006, the U.S. EPA adopted a reference dose (RfD) for perchlorate of 0.0007 mg/kg-day. This RfD equates to a drinking water equivalent level of 24.5 micrograms per liter (or 24.5 ppb). As a result of EPA establishing a reference dose for perchlorate, the DOD issued a policy letter that establishes 24 ppb as the "level of concern for managing perchlorate." The letter further states that, "Once established, DOD will comply with applicable state or federal promulgated standards whichever is more stringent." We have discussed the new DOD guidance with base-level environmental personnel at Hill Air Force Base (AFB), Edwards AFB, and Redstone Arsenal, who believe that sampling and treatment requirements will become more aggressive because of the DOD guidance and individual state reactions to establishment of the EPA RfD. In the State of California, the public health goal (PHG) remains at 6 ppb, and a maximum contaminant level (MCL) of 6 ppb has been proposed and is currently under review.

1.4 Stakeholder/End-User Issues

One objective of this demonstration was to work with the water utility and the California Department of Health Services (CDPH) to obtain a modified or revised permit that includes the WBA resin ion exchange treatment process for drinking water applications. To accomplish this, we worked closely with the water utility and with the regional CDPH representatives and developed a sampling and analysis plan to provide the data necessary to obtain permit modification. We are currently working with the water utility to modify their permit for CDPH review and acceptance. Acquiring the permit modification by the regional CDPH officials will facilitate permit modification by CDPH in other regions.

2. Technology Description

2.1 Technology Development and Application

Ion exchange using perchlorate-selective, weak base anion (WBA) resin is effective for treating perchlorate contamination in any surface, ground, or drinking water. The primary advantages of ion exchange using WBA resin are the ease and simplicity of regeneration, the small volume of spent regenerating solution produced, the resulting lower operation and maintenance cost of regeneration, and the lower cost and ease of disposal of the spent regenerating solution. This ion exchange process takes advantage of the pH dependent nature of WBA resins. At low pH, functional groups on these resins have a positive charge (i.e. $R-NH_3^+$) allowing for anion exchange. However, at high pH, the resin functional groups lose a proton and are uncharged (i.e. $R-NH_2$) allowing for regeneration. The chemistry of WBA resin ion exchange is shown in Figure 2-1.

WBA resin in free-base form ($R-NH_2$) is ionized ($R-NH_3^+$) by protonating with acid (H^+):



Protonated resin removes anions (A^-) from aqueous streams:



Spent resin ($R-NH_3-A$) is regenerated by neutralizing with caustic ($NaOH$), which liberates anions and returns resin to the free-base form:



Figure 2-1. Weak Base Anion Resin Chemistry

The ion exchange process using WBA resins is comprised of three unit operations: pretreatment, ion exchange, and post treatment (Figure 2-2). Spent resin was regenerated and protonated before being placed back in service. The perchlorate concentrated in the spent regenerating solution was scavenged using a small volume of strong base anion resin. The perchlorate-free regenerating solution can then be discharge and the scavenger resin incinerated. These operations are described below.

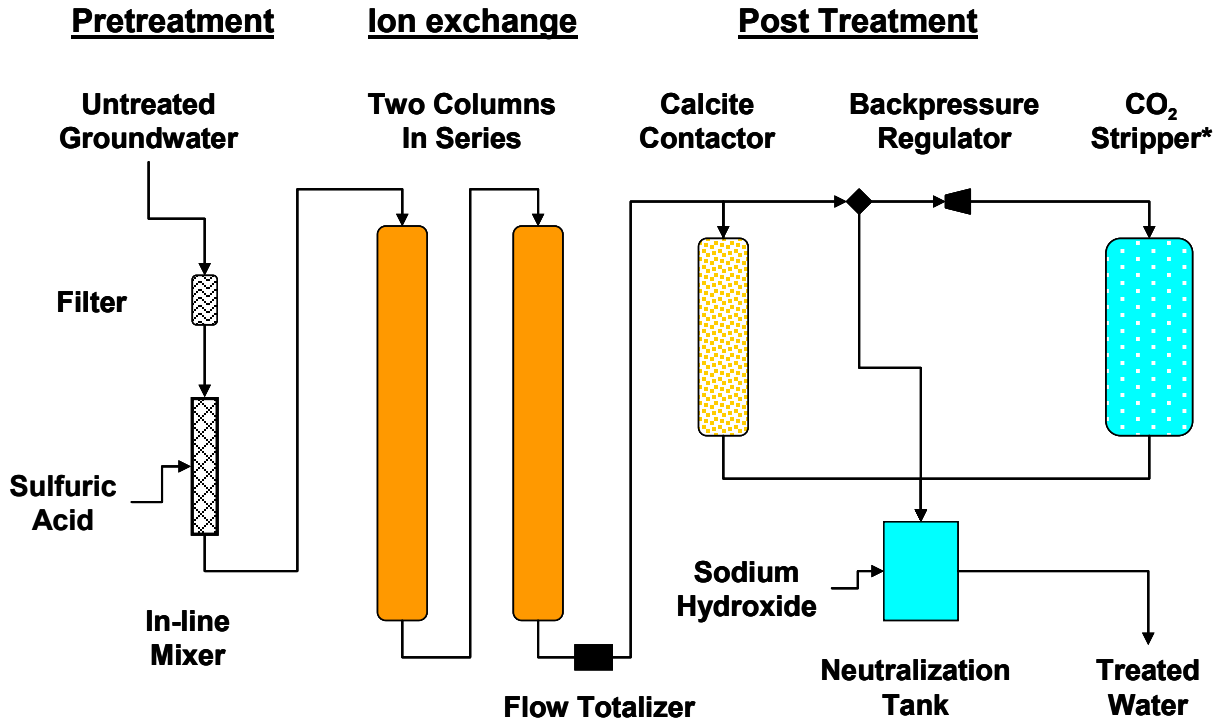

* CO2 stripping was accomplished using an air stripper and a membrane stripper using by Liqui-Cel membranes.

Figure 2-2. Demonstration Process Flow Diagram

Pretreatment:

The function of pretreatment is to reduce the pH of the contaminated groundwater. Groundwater from the well head was filtered and metered into the pressurized pH pretreatment system. For this demonstration, a McMaster-Carr high-capacity polyester filter cartridge was used (product no. 45235K95). The cartridge is made of FDA-compliant materials and is NSF certified to ANSI/NSF Standard 61. Filter size is 1 1/16" ID x 2 3/4" OD and 9 3/4" L and has a pore size of five microns.

An operational pH between 3 and 5 prevents resin functional groups from being neutralized. The feed pH was maintained at 4.0 by addition of sulfuric acid. This system consisted of a pH controller, an acid delivery system, and a circulation pump and mixing zone. The actual volume of the pressurized pretreatment system was approximately 1.215 gallons (4.6 liters). At a 24 BV/hr feed rate (12.68 gal/hr or 48 liters/hr water flow rate), the hydraulic residence time in the pretreatment unit was 5.75 minutes. At an operating pH of 4.0, alkalinity present in the groundwater rapidly converts to carbonic acid in equilibrium with carbon dioxide. A backpressure regulator was placed after the ion exchange columns to control system operating pressure at 10-20 psig. System pressure keeps carbon dioxide gas in solution as dissolved carbon dioxide and carbonic acid. The quantity of acid required for pretreatment is directly proportional to the alkalinity of the untreated water.

Ion Exchange:

Ion exchange was accomplished using two, clear-PVC ion exchange columns connected in series (lead-lag configuration). The ion exchange columns were 5 ft in height and had a 2-inch inside diameter. The ion exchange columns could be operated at resin bed depths between 30 and 40 inches, which is typical for commercial ion exchange systems. A 36-inch bed depth was used, which equates to 0.53 gallons (2-liters) of resin. The ion exchange columns were purposely sized to permit direct scale-up to commercial systems while minimizing the water flow rate required for the demonstration. When perchlorate breakthrough in the lead column exceeded 30 to 50% of the groundwater feed concentration, this column was removed from the system for regeneration and the lag column replaced the lead column. The freshly regenerated column was returned to the system in the lag position. This cycle was repeated throughout the demonstration. Treated water passed through a digital flow totalizer before post treatment to determine the volume of water treated.

Thirty to 50 percent breakthrough of the lead vessel in a lead-lag process is typical for commercial ion exchange operations. At 50% breakthrough, the resin in the lead column is loaded to greater than 95% of capacity. Therefore, little additional treatment capacity would be realized at a higher percentage of breakthrough. Operation in this manner provides significant margin of safety and permits operation using a single column during regeneration of the spent column.

Several WBA resins have been evaluated. Purolite D-4170 is the best performing resin evaluated to date and was used for this demonstration. This is the same resin that was used for the demonstration conducted at Redstone Arsenal.

Post Treatment:

Post treatment is required to restore pH and alkalinity of treated water to acceptable levels. Post treatment requirements are site specific and depend on corrosion or scaling potential of the groundwater. The post treatment system was designed to control the degree of carbon dioxide stripping and neutralization using sodium hydroxide and/or calcite. A combination of these processes was used to strip excess dissolved carbon dioxide, which reduces neutralization costs, and “dial in” treated water alkalinity and pH to the desired requirement. The treated water neutralization/holding tank had a residence time of approximately four hours, which provided ample time for equalization and neutralization.

Two options were demonstrated for stripping carbon dioxide from the treated water 1) air stripping and 2) membrane stripping with air sweep using Liqui-Cel membranes. Both were effective and resulted in the ability to dial-in treated water characteristics.

Regeneration & Protonation:

Regeneration was accomplished by increasing the pH of the spent resin to neutralize the functional groups. All regenerations were conducted onsite. The spent column was isolated from the ion exchange process and regenerated by circulating three bed volumes (1.59 gallons or 6 liters) of potable water through the resin bed for two hours or more. Sufficient sodium

hydroxide was added to the potable water to neutralize the resin exchange sites and maintain pH above 12.0. After regeneration was complete, spent regenerating solution was drained from the column and held for subsequent treatment. A rinse was conducted to remove residual perchlorate from the resin before protonation by flowing rinse water (single pass) through the resin bed. Rinse water was prepared by adjusting the pH of potable water to pH 9 using sodium hydroxide. The pH of 9 was selected to maintain the resin in the free-base form and facilitate removal of any residual perchlorate. The first three bed volumes (1.59 gallons or 6 liters) of this rinse was retained and used for the subsequent regeneration. This fraction of the rinse was sampled and analyzed for perchlorate. Rinsing was continued at a low flow rate (~2 BV/hr – 1.06 gal/hr or 4 L/hr) for approximately 16 hours (overnight). This resulted in a total rinse volume of 30 to 35 bed volumes (15.9-18.5 gal or 60-70 liters). All but the first three bed volumes (1.59 gallons or 6 liters) of rinse was returned to the pretreatment system and treated in the ion exchange process.

After the rinse was completed, protonation was accomplished by decreasing the pH of the resin. Protonation was accomplished by circulating three bed volumes (1.59 gallons or 6 liters) of perchlorate-free, potable water through the resin bed for two hours or more. Sufficient acid (H_2SO_4) was added to the water to protonate the resin exchange sites and maintain pH below 4.0. After the protonation was complete, the column was returned to service. The spent protonating solution was recovered, analyzed, neutralized and discharged.

Residuals Treatment:

Strong base anion resin Purolite A530E was used to scavenge perchlorate from the concentrated spent regenerant solution. This was conducted on site and no perchlorate-containing effluent was generated. The scavenger system consisted of two columns (15 mm internal diameter by 300 mm) in series. Each scavenger column contained 40 cubic centimeters (0.01 gal or 0.04 liters) of resin, which was enough resin to scavenge all of the perchlorate recovered from the regeneration from one or two ion exchange columns. After treatment of each batch of spent regenerant, the first scavenger column was removed from service and a fresh column was installed in the lag position. After confirming perchlorate was removed, the treated spent regenerant was neutralized using sulfuric acid and disposed. The spent resin was shipped to ARA's Panama City, FL laboratory for analysis and disposal.

2.2 Previous Testing of the Technology

As described in section 1.1, remediation of groundwater containing perchlorate using the weak base anion technology was successfully demonstrated at Redstone Arsenal under ESTCP project ER-0312. Detailed results of this demonstration are provided in the submitted Final Report (October 2, 2006) and Cost and Performance Report (October 31, 2006).

2.3 Factors Affecting Cost and Performance

The water quality parameters that affect cost and performance are alkalinity, hardness, perchlorate concentration, sulfate concentration, and treated water alkalinity. The amount of acid required to achieve operating pH is directly proportion to feed water alkalinity. Perchlorate concentration dictates the resin treatment capacity and regeneration frequency, which affects

regeneration cost. Hardness and desired alkalinity of treated water effect the caustic requirement for neutralization, which affects neutralization cost.

Sulfate concentration can also affect pretreatment cost. The most economical pretreatment approach is to use sulfuric acid. However, the use of sulfuric acid increases the sulfate concentration in the treated water. If feed alkalinity and sulfate concentrations are very high, residual sulfate concentration could exceed the secondary water treatment guideline of 250 mg/L. In such cases, it would be necessary to replace some or all of the sulfuric acid with the more expensive hydrochloric acid. However, the secondary MCL for sulfate in the state of California is 500 mg/L, so the application and effectiveness of this technology in California will not be limited.

2.4 Advantages and Limitations of the Technology

Three technologies are currently used commercially for remediating perchlorate-contaminated groundwater: 1) biodegradation, 2) ion exchange using regenerable resins, and 3) ion exchange using non-regenerable or disposable resins. The WBA resin technology takes advantage of the performance, favorable public perception, and regulatory acceptance of ion exchange while minimizing the liabilities of current ion exchange systems. These liabilities include: 1) high cost of perchlorate-selective resins currently in use, 2) large volume of residuals generated by regenerable systems, 3) difficulty and high cost of treating residuals, and 4) resin replacement and incineration costs for non-regenerable systems.

Weak base, perchlorate-selective resins do not have the treatment capacity of strong base, perchlorate-selective resins. Even so, overall cost savings may be substantial since the WBA resins can be economically regenerated. Pretreatment and post treatment steps required for the WBA resin process do add process complexity compared to single-use ion exchange systems. However, the complexity is not greater than other commercial, regenerable ion exchange technologies. Pretreatment and post treatment unit operations are very straight-forward pH control processes.

3. Demonstration Design

3.1 Performance Objectives

The primary means of assessing performance of WBA ion exchange, regeneration, and residual treatment during this drinking water demonstration was to collect and analyze samples of treated water for perchlorate. Analytical results were used to determine the treatment capacity of the WBA resin at the conditions tested. Operational data collected were used to validate operating cost of this technology. Table 3-1 lists the performance objectives for this demonstration and if the performance objectives were met. The following paragraphs describe the method(s) for evaluating each performance objective.

Table 3-1. Performance Objectives

Type of Performance Objective	Primary Performance Criteria	Expected Performance (Metric)	Actual Performance Objective Met?
Qualitative	1. System operability	No process interruptions	Yes
Qualitative	2. System reliability	Reliably treats perchlorate, controls pH and alkalinity	Yes
Qualitative	3. System scalability	Ability to predict performance for larger scale system(s)	Yes
Quantitative	4. Meet perchlorate regulatory standards for drinking water	Treated water \leq MCL (6 ppb)	Yes
Quantitative	5. Demonstrate WBA resin capacity for drinking water application	$> 12,000$ BV	No
Quantitative	6. Demonstrate post treatment "dial in" capability using stripping and neutralization	$1.0 > \text{LSI} > -1.0$ (i.e., non-corrosive & non-scaling)	Yes
Quantitative	7. Resin regeneration	No perchlorate bleed in subsequent test period \leq MCL (6ppb)	Yes
Quantitative	8. Process waste	<0.05 vol% residual	Yes
Quantitative	9. Low O&M treatment cost	$<\$100$ /acre-ft	Yes
Quantitative	10. Treatment of spent regenerating streams – scavenging of perchlorate	\leq MCL	Yes
Quantitative	11. Resin capacity following regenerations	Deviation of calculated perchlorate capacity does not exceed 10%	Unable to determine
Quantitative	12. Treatment flow rate	Operate at flow rate ≥ 3 gpm/ft ³	Yes

3.1.1 System Operability

The performance metric for assessing system operability was the ability of the system to operate as designed without process upsets or interrupted flow. As described in Section 2-1, this includes three units of operation: pretreatment, ion exchange, and post treatment. During the fifteen week demonstration, all unit operations functioned as designed and there were no process upsets or flow interruptions.

3.1.2 System Reliability

Since the process uses weak base anion resin, pretreatment of the influent to decrease the pH is important to maintain the resin in the ionized form. There was one occasion during the demonstration that the acid pump used for pretreatment lost prime due to a low volume level in the acid feed tank. According to data recorded by a data acquisition system, on July 31, 2006, there was a nine hour period during which the groundwater pH was not reduced below 6.9. During this period, the resin in the lead column acted as a buffer. The pH of the lag column effluent never exceeded 4.6 and perchlorate was not detected in samples collected from the lead and lag columns following this event. In a full-scale process, controls and alarms would be in place to halt treatment and alert an operator of pretreatment failure.

3.1.3 System Scalability

The treatment rate and the resin bed depth for the pilot demonstration was equivalent to the resin bed depth in full-scale ion exchange vessels. Assuming the perchlorate concentration does not change, the loading rate for the pilot demonstration is also equivalent. Therefore, the ion exchange performance demonstrated was representative of full-scale system performance with no scale-up constraints. Acid and caustic consumptions and operating conditions were recorded daily during each test period to predict full-scale consumptions.

3.1.4 Meet Regulatory Standards

The performance objective for meeting regulatory standards was based on an MCL of 6 ppb. Analyses were conducted by ARA using EPA method 314.0 and by a certified laboratory using IC/MS/MS (Babcock Laboratories - NELAP #: 02101CA and ELAP #: 1156). Table 3-2 is a summary of the analytical results (samples from test periods 2 and 4 were not analyzed by IC/MS/MS). Samples analyzed and reported in Table 3-2 were collected following the lag column at the conclusion of each test period. Each result is well below the proposed MCL in the State of California which is 6 ppb.

Table 3-2. Perchlorate Concentration of the Treated Water at the End of each Test Period

Test Period	Perchlorate Concentration (ppb)	
	ARA	Certified Laboratory
1	< 2.5	0.19
2	< 2.5	
3	< 2.5	0.11
4	<2.5	
5	< 2.5	0.29
6	< 2.5	0.53

3.1.5 Capacity – Bed Volumes Treated

The performance objective for this metric was the ability to treat greater than 12,000 bed volumes (Note: 1 bed volume = 0.53 gallons = 2 liters). This metric value was determined based on an estimate of water quality at well F17C prior to the demonstration. However, the actual water characteristics were different than the characteristics used to predict the metric goal. The perchlorate concentration was less than half the anticipated concentration (an average of 6.6 ppb versus the anticipated 15 ppb). Most importantly, the actual nitrate concentration of 33 ppm as nitrate was much higher than the anticipated 4 ppm as nitrate. Since the resin is also selective for nitrate, and the nitrate concentration relative to perchlorate was higher than anticipated, the actual treatment capacity as bed volumes was lower than expected.

To determine the average bed volumes of water treated at approximately 50% breakthrough, test periods 1 and 2 were grouped as a breakthrough cycle and test periods 5 and 6 were grouped as a breakthrough cycle. Test periods 3 and 4 were not included since they were fixed-duration, short cycles of one-week during which breakthrough did not occur. Perchlorate breakthrough curves of test periods 1 and 2 (cycle 1) and 5 and 6 (cycle 2) are shown in Figure 3-1. The 50% breakthrough concentration is identified as 3.3 ppb which is 50% of the average perchlorate concentration in the feed water. The method reporting and detection limits of EPA method 314.0 are also identified in the chart. The average bed volumes treated at 50% breakthrough for test periods 1 and 2 and 5 and 6 was 8,900 and 10,500, respectively. The average bed volumes treated for both breakthrough cycles was 9,700 bed volumes.

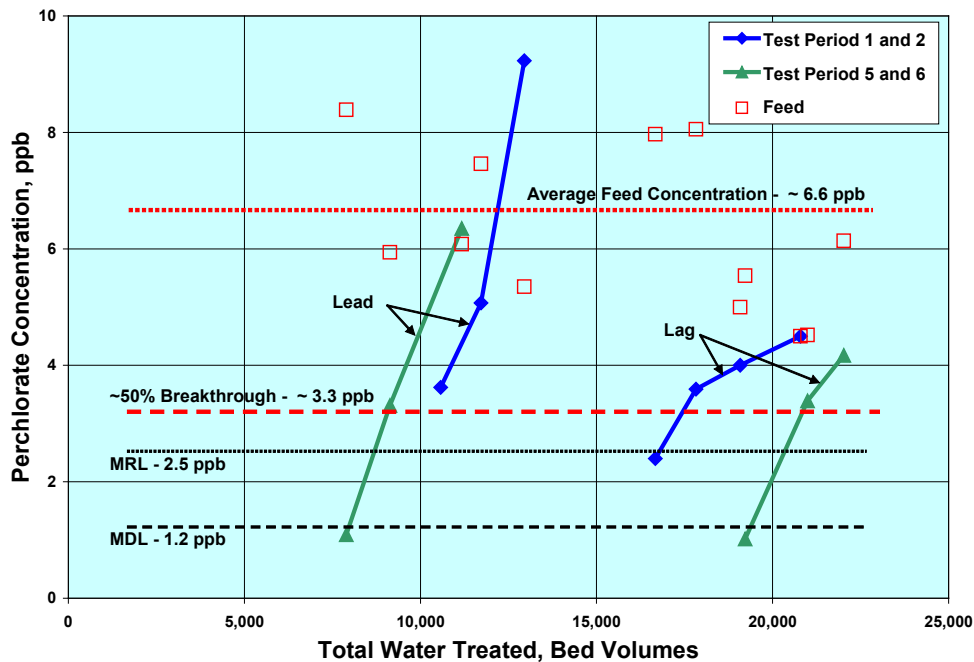

Figure 3-1. Comparison of WBA Resin Adsorption Capacity for Test Periods 1, 2, 5, & 6

During bench-scale resin tests conducted as part of the pilot demonstration at Redstone Arsenal (ESTCP Project No: CU-0312), it was noted that virgin resin exhibited lower treatment capacity than regenerated resin. Similarly, the 8,900 bed volume treatment capacity during the first two test periods with virgin resin in the lead columns was lower than the 10,500 treatment capacity during later test periods after the resin had been regenerated twice. Therefore, we believe that 9,700 bed volumes (5125 gallons or 19,400 liters) should be a conservative estimate of capacity in this water matrix.

3.1.6 Post Treatment “Dial In” Capability

The performance objective for post treatment was to control the treated water alkalinity and pH in a manner to attain suitable water quality while minimizing cost. The Langelier Saturation Index (LSI) was used as the indicator of water quality. This index predicts the calcium carbonate stability of water; that is, whether a water will precipitate, dissolve, or be in equilibrium with calcium carbonate (the LSI should be as close to zero as possible). The index determines the pH at which water is saturated in calcium carbonate. The LSI is expressed as the difference between the actual system pH and the saturation pH.

Key general physical characteristics and the LSI of the treated water at the end of each test period along with post treatment conditions are provided in Table 3-3. The performance metric was identified as the treated water having an LSI range between -1 and 1. By controlling the pH, the amount of dissolved carbon dioxide stripped from the treated water, and the volume of water passed over a calcite contactor column, it was demonstrated that treated water quality could be controlled to achieve a neutral LSI with alkalinity reduced to as low as 27 mg/L as CaCO₃.

Table 3-3. Post Treatment Water Quality

Treated Water at 77°F								
Parameter	Results							
Date	5/19/06	6/15/06	7/10/06	7/17/06	7/24/06	7/27/06	8/15/06	9/1/06
Test Period	1	2	2	3	4	5	5	6
Hardness, mg/L as CaCO ₃	160	193	183	210	215	171	172	179
Alkalinity, mg/L as CaCO ₃	9	54	33.2	39	27	15	12	12
pH	7.02	7.92	7.91	7.62	8.16	7.45	7.82	7.67
TDS, mg/L	320	380	370	380	440	420	376	285
LSI	-1.76	-0.01	-0.25	-0.41	-0.03	-1.09	-0.81	-0.93

The low LSI in test period 1 is reflective of the relatively low pH (7.02) and very low alkalinity compared to test period 2. Test period 4 results demonstrate that acceptable an LSI can be attained at alkalinity less than 30 mg/L calcium carbonate.

3.1.7 Resin Regeneration

Perchlorate bleed from freshly regenerated resin was identified as the performance metric for evaluating resin regeneration. Treated water samples were collected and analyzed for perchlorate after freshly regenerated columns were placed online. Results of these analyses are provided in Table 3-4, along with the duration that each regenerated column was in operation before sampling. Perchlorate bleed from resin following regeneration was always below 0.5 ppb. The low perchlorate bleed concentration indicated that thorough regeneration and rinsing were achieved.

Table 3-4. Perchlorate Concentration in Treated Water of Freshly Regenerated Column

Date	Test Pd	Flow Rate (BV/hr)	Hours Online	Bed Volumes Treated (BV)	Perchlorate (ppb)	
					ARA*	Babcock Labs**
19-May-06	1	24	28	700	<2.5	
15-Jun-06	2	24	50	1,200	<2.5	<1.0
13-Jul-06	3	24	16	300	<2.5	0.46
14-Jul-06	3	32	40	1,100	<2.5	0.33
16-Aug-06	6	24	1	24	<2.5	0.29

* ARA analyzed for perchlorate using ion chromatography (EPA Method 314.0) and had a method detection limit of 2.5 ppb.

** Babcock Laboratories analyzed for perchlorate using ion chromatography with tandem mass spectrometers (IC/MS/MS). The reporting detection limit was 0.10 ppb for all samples except for the one collected on June 15, 2006 when the detection limit was 1.0 ppb due to matrix effects.

3.1.8 Process Waste

The performance metric for process waste was to generate less than 0.05% waste as a function of treated water volume. As discussed in section 3.1.5, the treatment capacity of the resin is estimated to be 9,700 bed volumes (5125 gallons or 19,400 liters). The treatment capacity and the spent regenerant volume for each representative test period are identified in Table 3-5. For each test period, the percentage of waste generated as a function of treated water volume was less than the performance goal. Even if the treatment capacity did not exceed 8,900 bed volumes (17,800 liters), the maximum waste generated would have been 0.047% (using 8.3 liters of volume regenerant generated during test period 5). This is still less than the 0.05% goal.

Table 3-5. Regeneration Efficiency for WBA Resin Technology

Test Period	1	2	3	4	5
Water Treated Volume(L)	19,400	19,400	19,400	19,400	19,400
Regenerant Volume(L)	8.1	8.1	8.1	7.9	8.3
% Waste	0.042%	0.042%	0.042%	0.041%	0.043%

3.1.9 O&M Treatment Cost

Treatment cost analyses in Section 5 determined that the O&M cost for the WBA process ranges between \$85 and \$93 per acre foot depending on the size of the treatment system.

3.1.10 Treating Spent Regenerant

The performance criterion for treating spent regenerant was to remove perchlorate from the spent regeneration solutions to less than the MCL for perchlorate (proposed at 6 ppb in California). A scavenger process was used to treat spent regenerant. The process consisted of two columns packed with 40 cubic centimeters of strong base anion resin (Purolite A530E) and arranged in series. A530E is highly selective for perchlorate and performance was not affected by nitrate and sulfate, appreciably. Bench tests conducted demonstrated a loading capacity for perchlorate of 250 meq/L.

Spent regenerant was passed over the columns at a flow rate of 15 bed volumes per hour. After treatment, the lead column was removed and replaced with the lag column for the next regeneration. A fresh column was installed to replace the promoted lag column. Samples of the lead and lag column effluents were analyzed for perchlorate and other anions. Perchlorate in the treated spent regenerant was removed to concentrations below the detection limit (<2.5 ppb) after passing through the lead column. A summary of anion concentrations in the spent regenerant and treated spent regenerant is provided in Table 3-6.

Table 3-6. Anion Concentrations in Spent Regenerant Before and After Scavenging Treatment with SBA Resin

	Perchlorate	Nitrate	Sulfate	Chloride
Spent Regen Solution (mg/L)	10-40	3150	9800	160
Treated Regen Solution (mg/L)	< MRL*	3050	9700	230

* MRL was 2.5 ppb

3.1.11 Resin Capacity following Regeneration

The performance metric for this objective was that the deviation of the calculated perchlorate capacity as milliequivalents of perchlorate per liter of resin did not exceed 10% after regeneration. To calculate perchlorate capacity (meq of perchlorate loaded per liter of resin), an accurate mass balance must be conducted.

Two factors prevented an accurate mass balance calculation: 1) sampling occurred every second or third day and 2) the concentration of perchlorate analyzed in the feed water varied from 5ppb to 11 ppb. At this low concentration, a variation of 1 ppb in the groundwater concentration or the water analysis will introduce an error of 12 – 17 % in material balance calculations. Even slight instrument or dilution error or fluctuations in feed concentration would greatly influence the data result.

3.1.12 Treatment Flow Rate

The performance metric for this objective was to demonstrate a treatment rate of at least 3 gpm/ft³. The treatment rate for all test periods was 3 gpm/ft³ except for test period 4. During this week long short cycle, the treatment rate was 4 gpm/ft³. The surface loading rates for 3 and 4 gpm/ft³ treatment rates during these tests were 9.7 and 12.9 gpm/ft², respectively. No perchlorate bleed was observed for either of these treatment rates.

3.2 Selecting Test Site(s)

The main criteria for site selection included the following: 1) drinking water utility with 10-30 ppb perchlorate contamination in California, 2) site interest in hosting the demonstration and working with CDPH to modify their existing permit to include this technology, and 3) existing wells and infrastructure providing access to the contaminated waters. Based upon these criteria, the San Gabriel Valley Water District, Valley County Water District, East Valley Water District, the City of Colton, and the City of Rialto were considered. Representatives from each of these organizations were contacted to research available wells and infrastructure, water properties, and interest in hosting the demonstration. Representatives from Colton and Rialto indicated that they would be unable to support this demonstration due to other activities and ongoing demonstrations. Representatives from San Gabriel Valley Water District provided information for two potential sites, one in San Bernardino County and the other in Los Angeles County. Based upon their recommendation, well site F17, operated and managed by the Fontana Water Company and located San Bernardino County, was selected for the demonstration. The site map for plant F17 is provided as Appendix A.

3.3 Test Site Description

The Fontana Water Company is a retail investor-owned utility company that provides water to approximately 160,000 residents, mainly in the City of Fontana. The company also serves portions of the cities of Rancho Cucamonga and Rialto. Initially, wells F17B and F17C were to be used for this demonstration. However, well F17B was shut down and re-screened due to high nitrate concentrations. For this reason, only water from well F17C was used throughout the demonstration. Well F17C was drilled in 1994 and has a production rate of 3000 gpm. Currently, water from this well is treated by an ion exchange process that uses non-regenerable, strong base anion resin.

3.4 Pre-Demonstration Testing and Analysis

Fontana provided general water characteristics and perchlorate data for well F17C. Prior to initiating testing, water from well F17C was re-analyzed to provide a baseline. The parameters evaluated included general mineral and general physical properties and perchlorate. Results from this baseline are provided in Table 3-7.

Table 3-7. – Pre-Demonstration Water Quality for Well F17C

Parameter	Result	Unit
Perchlorate	8.0	µg/L
Nitrate (as NO ₃)	30.6	mg/L
Chloride	9.5	mg/L
Sulfate	13.8	mg/L
Fluoride	0.20	mg/L
Bicarbonate	186	mg/L
Carbonate	< 5.0	mg/L
Hydroxide	< 5.0	mg/L
Total Alkalinity (as CaCO ₃)	153	mg/L
Total Hardness (as CaCO ₃)	146	mg/L
Specific Conductance	380	Mmhos/cm
Total Dissolved Solids	240	mg/L
MBAS*	< 0.04	mg/L
pH	7.89	N/A
Calcium	42.7	mg/L
Copper	< 0.01	mg/L
Iron	0.307	mg/L
Magnesium	9.59	mg/L
Manganese	< 0.01	mg/L
Potassium	1.61	mg/L
Sodium	24.2	mg/L
Zinc	0.034	mg/L
Anions	4.10	meq/L
Cations	4.01	meq/L

* Methylene Blue Active Substances

3.5 Testing and Evaluation Plan

3.5.1 Demonstration Installation and Start-Up

The ion exchange pilot treatment system used during the demonstration at Redstone Arsenal (CU-0312) was modified for use in this drinking water demonstration. Modifications included fabrication and installation of: 1) column feed and effluent manifolds for flow flexibility, 2) a regeneration and protonation system for on-site regeneration, 3) a scavenger resin system to treat spent regenerating solution onsite, 4) a manifold and flow control system for the post treatment process, 5) a carbon dioxide stripping column, and 6) a calcite contacting column. The entire system was housed in an eight foot by twenty foot enclosed trailer that provided breakered power, climate control, and protection from the elements while in the field. Utility hookups, including power and communication, were coordinated with Fontana staff prior to field mobilization. The pilot system was transported to Fontana, CA and set up at the site selected. Set-up was accomplished in two days. The following images are of the ARA demonstration system at well site F17.



ARA demonstration trailer beside enclosure for well F-17C in Fontana, CA.



ARA demonstration trailer containing ion exchange equipment at well-site F-17 in Fontana, CA

The Purolite Company provided ARA with 1.0 cubic foot of commercial D-4170 resin from a single batch. ARA only used a fraction of this resin for this demonstration. The resin used for this demonstration and the demonstration at Redstone Arsenal, came from the same batch of Purolite D-4170 resin.

Ion exchange columns were prepared at the Panama City Research Facility prior to installation in the field. The standard resin-loading protocol used for this demonstration included the following steps: 1) load an accurately measured amount (2 liters per column) of virgin WBA resin (Purolite D-4170) in the free-base form using neutral pH, distilled water slurry, 2) rinse the resin with neutral pH, distilled water, 3) protonate the resin using sulfuric acid, 4) regenerate the resin using sodium hydroxide, and 5) re-protonate the resin using sulfuric acid. Before startup, the resin in each column was classified on site by circulating one gallon of distilled water with the pH adjusted to 4.0. The pilot system was manned full-time during the set-up and start-up period (2 weeks). Two local technicians were trained during this period. The responsibilities of the local technicians were to maintain system operation, record operational data, and collect and ship samples three times per week. The local technicians also responded to unforeseen operational or data acquisition anomalies with guidance from ARA. ARA personnel conducted on-site visits every 3 to 4 weeks to perform resin regeneration and scavenger treatment tests on the spent regenerant.

Disinfection of the pilot system was conducted prior to initiating the demonstration by flowing potable water at a pH of 12.5 or higher through all interconnecting piping. This solution was circulated through the piping for four hours. Following circulation, the high pH solution remained in the system for 12 hours. Under these conditions, bacterial cell walls lyse, effectively disinfecting the system. Prior to start up, the high pH solution was rinsed from the piping using potable water at the operational pH of 4.0.

Before operation, resin was always classified by up-flow fluidization as part of the protonation rinse process. Since the resin was regenerated every three to four weeks, intermediate backwashing was neither necessary nor desirable.

3.5.2 Period of Operation

The demonstration trailer was shipped from Panama City, FL on May 12, 2006 and delivered to Fontana, CA on May 16, 2006. After two days of set-up and column preparation, the system was initiated for groundwater treatment on May 18, 2006. From this date, the demonstration system was operated for approximately fifteen weeks until September 1, 2006.

Figure 3-2. Duration of each Test Period

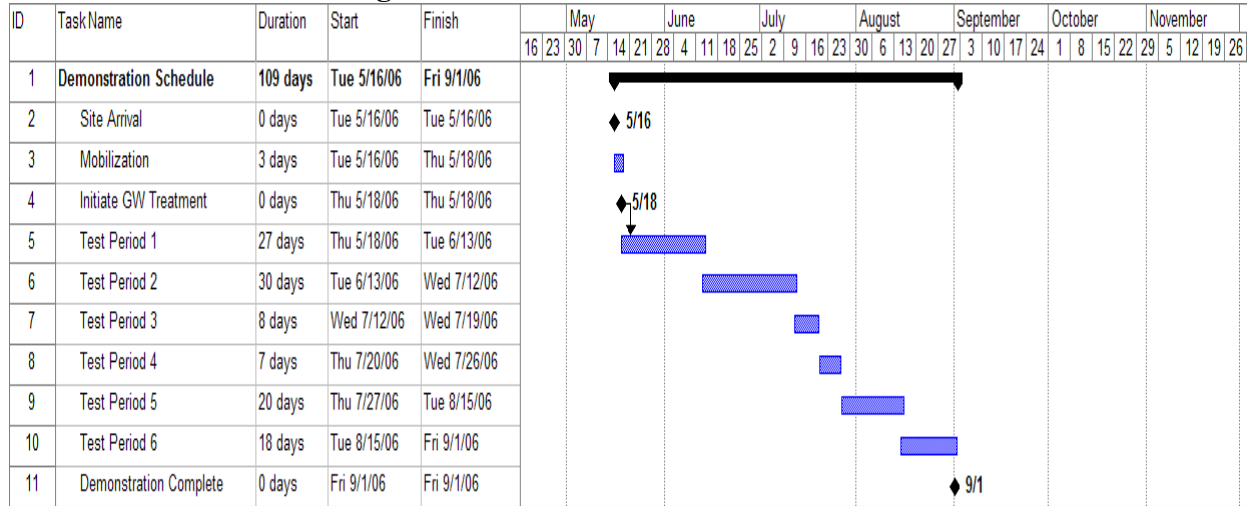

3.5.3 Amount /Treatment Rate of Material to be Treated

The volume of water treated during each test period and the total volume of water treated is listed in Table 3-8.

Table 3-8. Amount of Water Treated

Test Period	Flow Rate	Volume Treated		
	BV/hr	Bed Volumes	Gallons	Liters
1	24	15,100	7,980	30,200
2	24	16,100	8,500	32,200
3	32	5,100	2,700	10,200
4	32	4,100	2,170	8,200
5	24	11,600	6,130	23,200
6	24	10,900	5,760	21,800
TOTAL		62,900	33,240	125,800

3.5.4. Residuals Handling

Two process residuals were generated from the pilot demonstration: treated drinking water and treated spent regenerant water. Both process residuals were discharged, after confirming complete perchlorate removal, in accordance with instructions from the Fontana Water Company. Exhausted scavenger ion exchange resin was removed from the system and transported to ARA's Panama City facility for additional analysis and proper disposal.

3.5.5 Operating Parameters for the Technology

The pilot demonstration system was operated in a continuous flow manner. Only two ion exchange columns were used for this demonstration. Therefore, during regeneration of lead columns, which took from 30 to 54 hours, system operation continued with only one column online. A data acquisition system enabled monitoring of key performance parameters that included water pH and temperature at the pre-treatment loop, the lag ion exchange column, and the post-treatment tank; water treatment rate; and system treatment pressure. These operating parameters were recorded every ten minutes and were downloaded and monitored by ARA personnel. The key process variables for this demonstration were flow rate (BV/hr or gpm/ft^3) and post-treatment conditions (percentage of treated water air-stripped or membrane-stripped, treated in the calcite contactor, and neutralized by sodium hydroxide). Well F17C was the source water throughout this demonstration.

3.5.6 Experimental Design

Groundwater from Fontana well site F17C was contaminated with both perchlorate and nitrate. Perchlorate concentrations were typical for drinking water applications (~8 to 20 ppb). Nitrate concentrations were relatively high for typical drinking water applications (~33 ppm as nitrate) and did impact performance by slightly reducing treatment capacity. Bicarbonate concentration was also high (~190 mg/L), but typical for groundwater in the southwestern United States. Since alkalinity is a major performance and cost driver for this technology, water at the Fontana site provided a rigorous demonstration of the WBA resin technology.

Six test periods were conducted during this demonstration. Four test periods were breakthrough tests (1, 2, 5, and 6). During these tests, test periods were defined as the period from initiation of flow through a new column in the lead position, until the column was removed from service for regeneration. The specific flow rate during breakthrough tests was $3\text{gpm}/\text{ft}^3$, or a surface loading rate of $9.7\text{gpm}/\text{ft}^2$. During regeneration of the spent column, the lag column remained online and treated water in a single column. The remaining two test periods (3 and 4) were short-cycle tests. Short-cycle tests were defined as a column that is regenerated, after approximately one week on-line and before breakthrough was observed. These short-cycle tests were conducted to maximize the number of regenerations per column and minimize the duration of the demonstration. The short-cycle test during test period 3 was also used to evaluate perchlorate removal efficiency at a higher specific flow rate ($4\text{gpm}/\text{ft}^3$ or $12.9\text{gpm}/\text{ft}^2$ surface loading rate).

The conditions for each test period are identified in Table 3-9. Conditions identified include test period duration, flow rate, and pretreatment and post treatment settings. Within a test period, these settings may have been adjusted and are reflected in the test matrix. In most cases, adjustments were made to the post treatment settings; however, a flow adjustment was made during test period 3 (3A and 3B) to evaluate treatment performance at a higher flow rate.

Table 3-9. Test Matrix

Test Period	1	2A	2B	3A	3B	3C	4	5A	5B	6
Start date	5/18/2006	6/13/2006	6/15/2006	7/12/2006	7/13/2006	7/17/2006	7/19/2006	7/25/2006	7/27/2006	8/15/2006
End date	6/13/2006	6/15/2006	7/11/2006	7/13/2006	7/17/2006	7/19/2006	7/25/2006	7/27/2006	8/15/2006	9/1/2006
Duration (days)	26	2	26	1	4	2	6	2	19	17
System pressure (psig)	15.0	15.0	15.0	15.0	15.0	15.0	15.0	15.0	15.0	15.0
Flow rate										
BV/hr	24	24	24	24	32	24	24	24	24	24
gpm/ft ³	3	3	3	3	4	3	3	3	3	3
gpm/ft ²	9.7	9.7	9.7	9.7	12.9	9.7	9.7	9.7	9.7	9.7
Pretreatment										
Acid	H ₂ SO ₄	H ₂ SO ₄	H ₂ SO ₄	H ₂ SO ₄	H ₂ SO ₄	H ₂ SO ₄	H ₂ SO ₄	H ₂ SO ₄	H ₂ SO ₄	H ₂ SO ₄
Concentration (% v/v)	5	5	5	5	5	5	5	5	5	6
pH Setpoint	4.0	4.0	4.0	3.8	3.5	3.7	3.7	3.9	3.9	3.9
Post treatment										
Base	NaOH	NaOH	NaOH	NaOH	NaOH	NaOH	NaOH	NaOH	NaOH	NaOH
Concentration (% v/v)	5	5	5	5	5	5	5	5	5	5
pH Setpoint	6.8	6.8	6.8	6.8	6.8	6.8	6.8	6.8	6.8	6.8
Air strip (percent flow)	100	80	90	90	90	0	0	0	0	0
Calcite contactor (percent flow)	0	20	10	10	10	100	100	100	100	100
Membrane strip (percent flow)	0	0	0	0	0	100	100	100	100	100
Membrane strip (condition)	0	0	0	0	0	Air Sweep	Air Sweep	Air Sweep	10" Hg	10" Hg

Performance of the post-treatment process was evaluated by determining the Langelier Saturation Index (LSI) of the treated water as the indicator of water quality. Variables of post treatment were adjusted by varying the fraction of treated water that received CO₂ stripping, the fraction that flowed through the calcite contactor, and the fraction bypassed stripping and calcite contact and neutralized in the post-treatment tank by addition of sodium hydroxide.

Five regenerations were accomplished using a batch process (Figure 3-3). Regeneration solution was prepared by adding a stoichiometric amount of caustic plus 10% excess to three bed volumes of potable water. This solution was circulated over the resin bed for approximately four hours. During circulation, the pH was monitored to ensure it remained above 12.0. Following regeneration, the solution was drained from the column and collected for treatment. A rinse was conducted to adequately remove residual perchlorate from the regenerated resin bed, which minimized/eliminated perchlorate bleed at startup. The pH of the rinse water was maintained at 9.0 or greater. The first three bed volumes (1.59 gallons or 6 liters) of rinse was collected and used for the subsequent regeneration. The remainder of the spent rinse water was diverted to the front end of the system for treatment in the online column. Samples of the online column effluent were analyzed for perchlorate. Analyses confirmed that perchlorate did not bleed through the online column during treatment of the groundwater and rinse water. Following regeneration and rinsing, the resin was protonated and classified before the column was returned to service in the lag position.

A zero discharge scavenger process was used to treat spent regenerant (Figure 3-4). The process consisted of two, 15 mm I.D. columns packed with 24 cubic centimeters of strong base anion resin (Purolite A530E) and arranged in series. Spent regenerant was passed over the columns at a flow rate of 15 bed volumes per hour (2 gpm/ft³, four minute detention time). After treatment, the lead column was removed and replaced with the lag column for the next regeneration. A fresh column was installed to replace the promoted lag column. Samples of the lead and lag column effluents were analyzed for perchlorate and other anions.

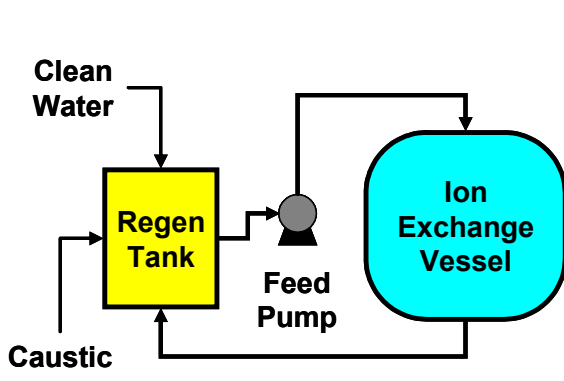

Figure 3-3. Batch Regeneration

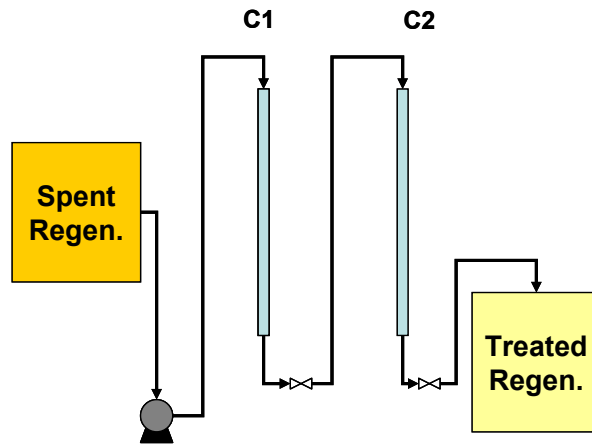

Figure 3-4. Scavenger Apparatus

3.5.7 Sampling Plan

The collection of representative samples during execution of this project was vitally important to evaluate the success of project objectives. Samples were collected at five locations during the field demonstration effort: 1) untreated groundwater, 2) pretreated groundwater, 3) lead column effluent, 4) lag column effluent, and 5) treated water. The schematic shown in Figure 3-5 identifies the sampling locations. Samples were analyzed by standard laboratory techniques for anions, general mineral and physical properties, nitrosamines and microbial growth. Grab samples were collected at least three times per week. Operational data including pH, flow rate, and pressure were collected and stored by the data acquisition system. The samples collected and analyzed for perchlorate were used to determine overall contaminant removal and process efficiency.

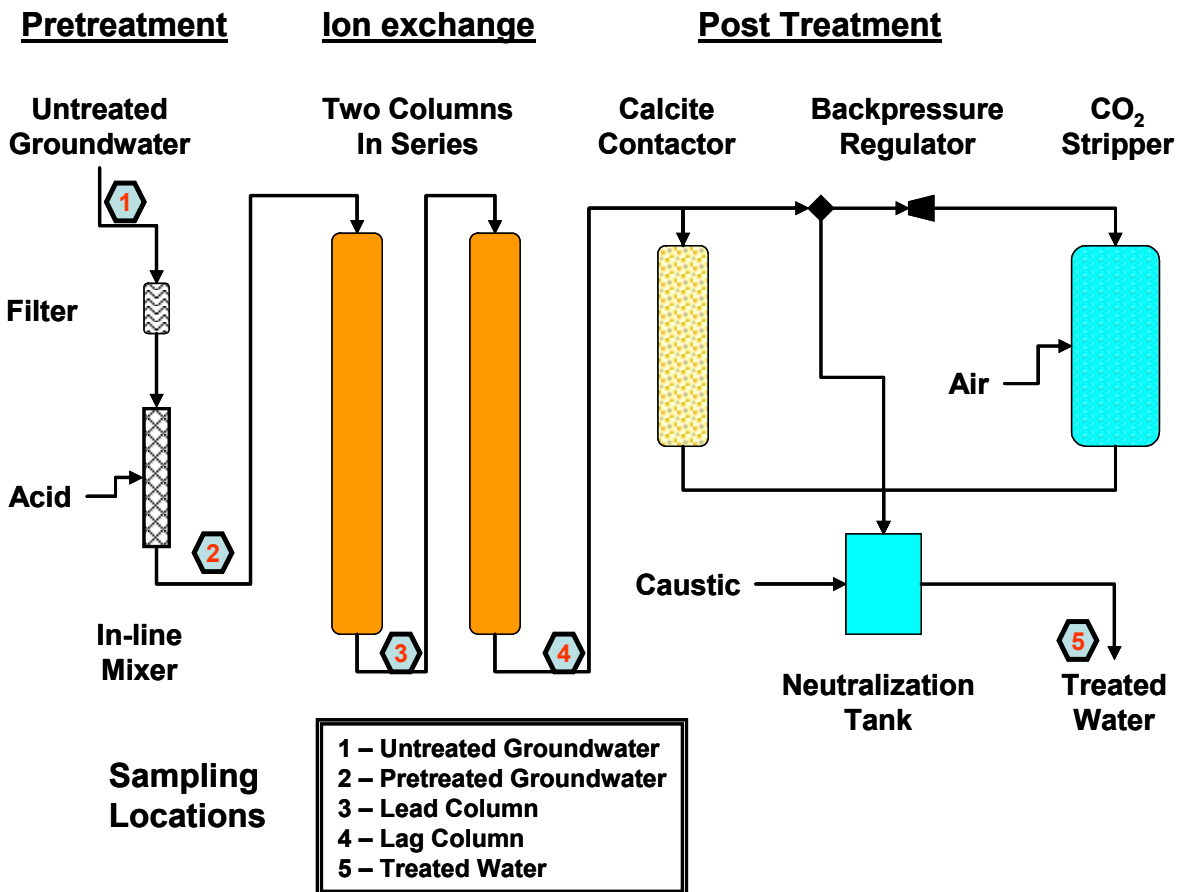

Figure 3-5. Pilot System Process Schematic with Sampling Locations

All samples were analyzed by ARA or a certified laboratory. A summary of analytes, methods, sampling points, and sampling frequencies is provided Tables 3-10, 3-11, and 3-12. The number of samples collected does not include duplicates or QA/QC samples collected and analyzed in accordance with the QAPP. Operational data such as pH, flow rate, and pressure were manually

recorded during each site visit and continually recorded and stored by the data acquisition system. At least one trip blank and one duplicate sample was included in each sample shipment to ARA and/or a certified laboratory for perchlorate analysis.

Table 3-10. Sampling Summary for ESTCP Pilot Demonstration during Test Periods 1 & 2

Certified Laboratory				
Parameter	Sample Point	Sample Frequency	Method	#Samples Collected
Perchlorate	2 and 5	24 hour after startup and final	EPA 314.0 or by IC-MS/MS or LC-MS/MS	8
Anions (Chloride, Nitrate, & Sulfate)	2 and 5	24 hour after startup and final	EPA 300.1	8
General physical & mineral*	2 and 5	24 hour after startup and final and at any post-treatment condition change	Various (see Table A-6)	8
Nitrosamines**	1, 3, and 4	Influent at beginning of demonstration; Treated water sampled at start up (<24BVs); at one week; and after regeneration	EPA 521	9
Heterotrophic Plate Count	3 and 4	24 hour after startup and final	9215	8
Total Coliform	3 and 4	24 hour after startup and final	9221	8
ARA				
Parameter	Sample Point	Sample Frequency	Method	#Samples Collected
Perchlorate	1,2,3,4,5	Startup - 2, 20, and 100 bed volumes; normal operation - 3X per week	EPA 314.0	135
Anions (Chloride, Nitrate, & Sulfate)	1,2,3,4, 5	Startup - 2, 20, and 100 bed volumes; normal operation - weekly	EPA 300.1	55

*General physical and mineral parameters include alkalinity, hardness, color, turbidity, conductance, pH, solids (TS/TDS), and metals (Ca, Cu, Fe, Mg, Mn, K, Na & Zn). Specific methods are listed in Table A-6.

** Nitrosamines include NDMA, NDEA, NDPA, NDBA, NMEA, NPIP, NYPR, NDPhA, NMOR

Table 3-11. Sampling Summary for ESTCP Pilot Demonstration during Test Periods 3 & 4

Certified Laboratory				
Parameter	Sample Point	Sample Frequency	Method	#Samples Collected
Perchlorate	2 and 5	Final	EPA 314.0 or by IC-MS/MS or LC-MS/MS	4
Anions (Chloride, Nitrate, & Sulfate)	2 and 5	Final	EPA 300.1	4
General physical & mineral*	5	Final	Various (see Table A-6)	2
Nitrosamines**	None			
ARA				
Parameter	Sample Point	Sample Frequency	Method	#Samples Collected
Perchlorate	1,2,3,4,5	Startup - 2, 20, and 100 bed volumes; normal operation - daily	EPA 314.0	65
Anions (Chloride, Nitrate, & Sulfate)	1,2,3,4, 5	Startup - 2, 20, and 100 bed volumes; normal operation - 3 X per week	EPA 300.1	45

*General physical and mineral parameters include alkalinity, hardness, color, turbidity, conductance, pH, solids (TS/TDS), and metals (Ca, Cu, Fe, Mg, Mn, K, Na & Zn). Specific methods are listed in Table A-6.

** Nitrosamines include NDMA, NDEA, NDPA, NDBA, NMEA, NPIP, NYPR, NDPhA, NMOR

Table 3-12. Sampling Summary for ESTCP Pilot Demonstration during Test Periods 5 & 6

Certified Laboratory				
Parameter	Sample Point	Sample Frequency	Method	#Samples Collected
Perchlorate	2 and 5	24 hour after startup and final	EPA 314.0 or by IC-MS/MS or LC-MS/MS	8
Anions (Chloride, Nitrate, & Sulfate)	2 and 5	24 hour after startup and final	EPA 300.1	8
General physical & mineral*	2 and 5	24 hour after startup and final and at any post-treatment condition change	Various (see Table A-6)	8
Nitrosamines **	3 and 4	Final for test period 5; Startup for test period 6	EPA 521	4
Heterotrophic Plate Count	3 and 4	24 hour after startup and final	9215	8
Total Coliform	3 and 4	24 hour after startup and final	9221	8
ARA				
Parameter	Sample Point	Sample Frequency	Method	#Samples Collected
Perchlorate	1,2,3,4,5	Startup - 2, 20, and 100 bed volumes; normal operation - 3X per week	EPA 314.0	135
Anions (Chloride, Nitrate, & Sulfate)	1,2,3,4, 5	Startup - 2, 20, and 100 bed volumes; normal operation - weekly	EPA 300.1	55

* General physical scan includes pH, color, turbidity, total alkalinity, total hardness, conductance, TDS, calcium, copper, iron, magnesium manganese, potassium, sodium, and zinc.

** Nitrosamines include NDMA, NDEA, NDPA, NDBA, NMEA, NPIP, NYPR, NDPhA, NMOR

Table 3-13 provides a sampling summary for the effluents of regeneration and residual treatment processes. Before initiating any of these processes, the influent was analyzed to determine initial perchlorate and other anion concentrations as well as pH.

Table 3-13. Sampling Summary for Regeneration and Residual Treatments

Process	Parameter	Sample Frequency	Method	#Samples Collected
Regeneration	Perchlorate	Each BV* & Final Composite	EPA 314.0	8
	Anions	Final Composite	EPA 300.1	8
	pH	Each BV & Final Composite	SM 4500	Continuous
Residual Treatment	Perchlorate	Each BV & Final Composite	EPA 314.0	21
	Anions	Final Composite	EPA 300.1	21
	pH	Final Composite	SM 4500	8

* BV – Bed volume

Table 3-14 lists the minimum sample volume, holding time, and preservative for each analytical method used during the field demonstration.

Table 3-14. Analysis Parameters

Parameter	Matrix	Method	Volume	Container & Preservation	Hold Time
Perchlorate	Aqueous	EPA 314.0	100 ml	HDPE, Cool 4°C	28 days
Anions	Aqueous	EPA 300.1	100 ml	HDPE, Cool 4°C	28 days
Turbidity	Aqueous	SM 2130B	100 ml	HDPE, Cool 4°C	48 hrs
Color	Aqueous	SM 2120B	50 ml	HDPE, Cool 4°C	48 hrs
Hardness	Aqueous	SM 2340	100 ml	HDPE, Cool 4°C, ph<2, HNO3	6 month
Alkalinity	Aqueous	SM 2320B	100 ml	HDPE, Cool 4°C	14 days
Conductance	Aqueous	SM 2520	100 ml	HDPE, Cool 4°C	28 days
pH	Aqueous	SM 4500	5 ml	N/A	Immediate
Solids (TS/TDS)	Aqueous	SM 2540	100 ml	HDPE, Cool 4°C	7 days
Metals (Ca, Cu, Fe, Mg, Mn, K, Na, Zn)	Aqueous	SM 3125	200 ml	HDPE, ph<2, HNO3	6 month
Nitrosamines (NDMA, NDEA, & NDPA)	Aqueous	EPA 521 and/or 8270	1000 ml	glass, Cool 4°C, 80-100mg Na ₂ S ₂ O ₃	14 days
Heterotrophic Plate Count	Aqueous	SM 9215	100 ml	Presterilized container, Cool 4°C	16 hours
Total Coliform	Aqueous	SM 9221	100 ml	Presterilized test tubes, Cool 4°C	16 hours

A complete sampling and analysis plan detailing analytical techniques, QA/QC requirements and sampling procedures is included in the QAPP, attached as Appendix B.

3.5.8 Demobilization

The system was sampled the final time and shut down on 9/1/06. Disconnection of utility and communication hookups was conducted from November 6th through 8th. The demonstration system was removed from the site on November 9, 2006. The site was returned to pre-demonstration conditions.

3.6 Selection of Analytical/Testing Methods

The critical parameter for this study is the analysis of anions, specifically perchlorate, in drinking water and in spent regenerating solution. Throughout the demonstration, the concentration of the anions was monitored to assess the performance. Perchlorate was analyzed at ARA's laboratory in Panama City, Florida, using EPA Method 314.0. EPA method 300.1 was used to analyze for other anions including chloride, nitrate, and sulfate. Additional analytical measurements such pH, conductivity, solids, metals, color, turbidity, hardness, alkalinity, and NDMA were performed using the appropriate Standard/EPA methods. Split sampling for perchlorate and anions were conducted for analysis by a certified laboratory. A listing of analytical procedures is provided in Table 3-15 with detailed descriptions of the analytical methods used during this demonstration included with the QAPP, attached as Appendix B.

Table 3-15. Analytical Procedures for the Proposed Study

Parameter	Matrix	Lab	Method	Method Type
Perchlorate	Aqueous	ARA	EPA 314.0	Ion Chromatograph
Anions	Aqueous	ARA	EPA 300.1	Ion Chromatograph
pH	Aqueous	ARA	SM 4500	Electrometric
General Physical/ Mineral Scan*	Aqueous	NELAP Certified	Various	Various
Nitrosamines**	Aqueous	NELAP Certified	EPA 521	Gas Chromatograph – Mass Spec

Notes: **General physical scan includes pH, color, turbidity, total alkalinity, total hardness, conductance, TDS, calcium, copper, iron, magnesium manganese, potassium, sodium, and zinc. ** Nitrosamines include NDMA, NDEA, NDPA, NDBA, NMEA, NPIP, NYPR, NDPhA, NMOR.

3.7 Selection of Analytical/Testing Laboratory

Samples were analyzed for perchlorate, other inorganic anions, and basic water quality parameters at ARA's in-house laboratory. Select samples were split and shipped to Associated Laboratories and/or Babcock Laboratory for an external confirmatory analysis for perchlorate as well as other general mineral and physical analyses. The address of each laboratory is listed below:

In-House Analyses

Applied Research Associates, Inc.
430 West 5th Street, Suite 700
Panama City, Florida, 32401
Phone #: 850-914-3188

External Analyses

Associated Laboratories
806 N. Batavia
Orange, CA 92868
Phone #: 714-771-6900
NELAP #: 04232CA

Babcock Laboratory
6100 Quail Valley Court
Riverside, CA 92507
Phone #: 951-653-3351
NELAP #: 02101CA
ELAP #: 1156

4. Performance Assessment

4.1 Performance Criteria

Performance criteria and a description of how the criteria were assessed are provided in Table 4-1.

Table 4-1. Performance Criteria

Performance Criteria	Description	Primary or Secondary
System Operability	System operates as designed and configured without interruptions due to process failure	Primary
System Reliability	<ul style="list-style-type: none"> Perchlorate leakage pH control CO₂ management 	Primary Secondary Secondary
Contaminant Reduction	Removal of perchlorate from drinking water via pump-and-treat ion exchange process to below the MCL	Primary
WBA Resin Capacity	Drinking water treatment capacity	Primary
Post Treatment Capability	Ability to adjust post-treatment operations to “dial in” treated water quality requirements	Secondary
Resin Regeneration	Effective and efficient regeneration and rinse of WBA resin enabling reuse	Primary
Process Waste	Small volume of spent regenerating solution (<0.05%)	Primary
Scavenging	Remove perchlorate from concentrated regenerant stream using strong base anion resin scavenger process	Primary
Cost	Low O&M treatment cost	Primary
Scale-Up Constraints	<ul style="list-style-type: none"> Representative bed depth Representative flow rate Pre/Post treatment scale 	Secondary
Resin performance after regeneration	Deviation of calculated perchlorate capacity does not exceed 10%	Primary

4.2 Performance Confirmation Methods

The effectiveness and success of this demonstration were measured against the performance objectives detailed in Section 4.1. To ensure that proper data collection and analytical techniques were followed, a Quality Assurance Project Plan (QAPP) with detailed instructions specific for this demonstration was developed and followed. This QAPP is attached as Appendix B. Table 4.2 summarizes the expected performance, performance confirmation methods, and actual performance.

Table 4-2. Expected Performance and Performance Confirmation Methods

Performance Criteria	Expected Performance Metric (pre demo)	Performance Confirmation Methods	Actual (Post Demo)
PRIMARY CRITERIA (Performance Objectives)			
System Operability	System operates as designed and configured without process interruptions due to process failures	Record any process interruptions and determine cause	No process interruptions or upsets occurred due to process design or system failure.
System Reliability	Very little perchlorate leakage	EPA method 314.0	The system reliably removed perchlorate with no leakage observed, even during regenerations.
Contaminant Reduction	Remove perchlorate to ≤ 4 ppb	EPA method 314.0	Perchlorate concentration in the treated water was below the criteria (4 ppb) in the lead columns until breakthrough. In the lag columns, perchlorate concentration was always below 0.5 ppb.
WBA Resin Capacity	Drinking water treatment capacity $>12,000$ bed volumes	Treatment capacity/ breakthrough analysis	The average treatment capacity was approximately 9,700 bed volumes. See section 3.1.5 for a detailed discussion of this performance criterion.
Resin Regeneration	Effective and efficient regeneration and rinse of WBA resin enabling reuse without substantial perchlorate bleed	EPA method 314.0	Perchlorate concentrations in treated water immediately after resin regeneration never exceeded 0.5 ppb. See section 3.1.7.
Process Waste	Volume of spent regeneration solution is $< 0.05\%$ of the water treated	Measure spent regenerant volume and volume of treated water using calibrated flow meters	The percentage of spent regenerant as a function of the estimated treatment capacity (19,400 L) was determined for test periods 1 through 5. All were below the expected metric of 0.05%. See section 3.1.8.
Scavenging	Remove ClO_4^- from regenerant solution to less than MCL	EPA method 314.0	Perchlorate concentration in all treated spent regenerant samples was always below the detection limit (2.5 ppb).
Cost	Low O&M treatment cost	Determine O&M cost from performance data	O&M cost calculated to be less than \$100/AF
Perchlorate Capacity	Deviation of calculated perchlorate capacity does not exceed 10%	Calculate perchlorate sorbed to resin during treatment and perchlorate recovered during regeneration for all test periods and compare.	Unable to evaluate this criterion due to very low and fluctuating perchlorate concentration in the groundwater. (See section 3.1.11)

**Table 4-2. Expected Performance and Performance Confirmation Methods
 (Continued)**

Performance Criteria	Expected Performance Metric (pre demo)	Performance Confirmation Methods	Actual (Post Demo)
SECONDARY CRITERIA (Performance Objectives)			
System Reliability	pH Control	Online pH monitor recorded with DAS	The data acquisition system recorded a nine hour period without pretreatment pH control (See section 3.1.2). The pH of the lag column effluent never exceeded 4.6 and no perchlorate dumping was observed
	CO ₂ management	Influent/Effluent alkalinity measurements	Alkalinity was managed by stripping dissolved CO ₂ and restoring alkalinity using a calcite contactor. An air stripping unit effectively stripped CO ₂ during the first three test periods. A membrane stripping unit effectively stripped CO ₂ for the remaining test periods.
Post Treatment Capability	Able to “dial in” post treatment stripping and neutralizing controls based on treated water requirements	pH and alkalinity of post treated water compared to requirements. LSI analyses.	LSI near zero attained at alkalinities reduced to < 30 mg/L.
Scale-Up Constraints	Representative bed depths, flow rates, pre/post treatment scale	System meets primary performance criteria	Resin bed depth for the pilot demonstration was equivalent to the resin bed depth in full-scale ion exchange vessels. Therefore, the ion exchange performance demonstrated was representative of full-scale system performance with no scale-up constraints.

Many of the performance criteria were based on comparing perchlorate concentrations of untreated groundwater or pretreated groundwater to treated water. For this reason, care was taken to ensure that sampling and analysis was compliant with the attached QAPP (Appendix B). Quality control results for perchlorate analyses are provided in Appendix C. During each test period, split samples were sent to a certified laboratory for analyses. The percentage of split samples sent for perchlorate analysis for each sample location is identified in Table 4-3.

Table 4.3. Number of Split Samples Analyzed for Perchlorate

Sample Location	1	2	3	4	5
ARA	57	57	74	61	56
Associated	5	13	4	1	1
Babcock	0	0	5	11	0
Split to Associated	9%	23%	5%	2%	2%
Split to Babcock	0%	0%	7%	18%	0%
Split to Certified Labs	9%	23%	12%	20%	2%

4.3 Data Analysis, Interpretation and Evaluation

The performance objective results were evaluated against the expected performance metric to determine success of the demonstration. The data collected were analyzed against process variables to identify correlation between operating variables and performance. Project performance results were compared to existing drinking water treatment processes for perchlorate. These processes include regenerable ion exchange processes that use salt as the regenerating agent such as the Calgon ISEP[®] process and conventional lead-lag processes. They also include single use ion exchange processes that use strong base anion resins that are incinerated after their perchlorate loading capacity is reached.

Perchlorate mass balance calculations were conducted during the demonstration at Redstone Arsenal. However, the very low concentration of perchlorate in the drinking water at Fontana (6-8 ppb), in addition to sampling every second or third day made it unrealistic for accurate mass balance calculations. At this low concentration, a variation of 1 ppb in the groundwater concentration or the water analysis will introduce an error of 12 – 17 % in material balance calculations.

A cost comparison is provided in Section 5.3 and key performance benefits compared to brine regenerable SBA resin are listed below:

- **Low O&M Cost.** < \$100 per acre-foot compared to ≥ \$200 per acre foot for SBA processes
- **Low Effluent Volume.** 0.02 to 0.05% of treated water. Twenty to fifty times more efficient than regenerating with brine
- **Inexpensive Zero-Discharge Process.** Use of SBA scavenger resin. Allows for treated water to be discharged to sewer.
- **Standard Ion Exchange Equipment.** Fixed bed vessels, lead-lag configuration.
- **Use of Typical Water Treatment Chemicals for Regeneration.** NaOH, H₂SO₄, Na₂CO₃, CaCO₃.

Issues associated with the use of WBA resin technology for perchlorate include:

- **Added Complexity.** Requires pretreatment and post treatment operations. Additional labor required for operation and maintenance.
- **Added Chemicals.** Acid and caustic must be added to the product water. Potential safety issues associated with handling acid and caustic.
- **Higher Capital Investment.** Additional unit operations and foot print.

5. Cost Assessment

5.1 Cost Reporting

Based upon demonstration results, capital and O&M cost data were developed for a full-scale (1000 gpm) groundwater treatment system using the WBA process. The cost data are representative for treating groundwater containing low concentrations of perchlorate typical for most drinking water applications. The following sections identify and describe assumptions and design bases used for cost development.

5.1.1 Capital Cost

5.1.1.1 Process Configuration

The process configuration in Figure 5-1 is the basis for capital and operating cost analysis. In this configuration, sulfuric acid is added to the feed water under pressure to lower pH to approximately 4.3. After ion exchange in a two-stage, lead-lag vessel configuration, post treatment is accomplished by a combination of membrane degassing, calcite treating, and pH adjustment. Liqui-Cel membranes will be used to degas approximately 90 to 95% of the treated water and the remaining 5 to 10% passed through a calcite contactor. Caustic will be added if necessary for final pH adjustment. For large applications (>1000 to 3000 gpm), degassing may be more economically accomplished using an air stripper. Pretreatment and post treatment processes will vary dependent on water composition, presence of co-contaminants, flow rate, and local requirements. Cost data developed for treating spent regenerant in this scenario are based on using the zero discharge scavenger method.

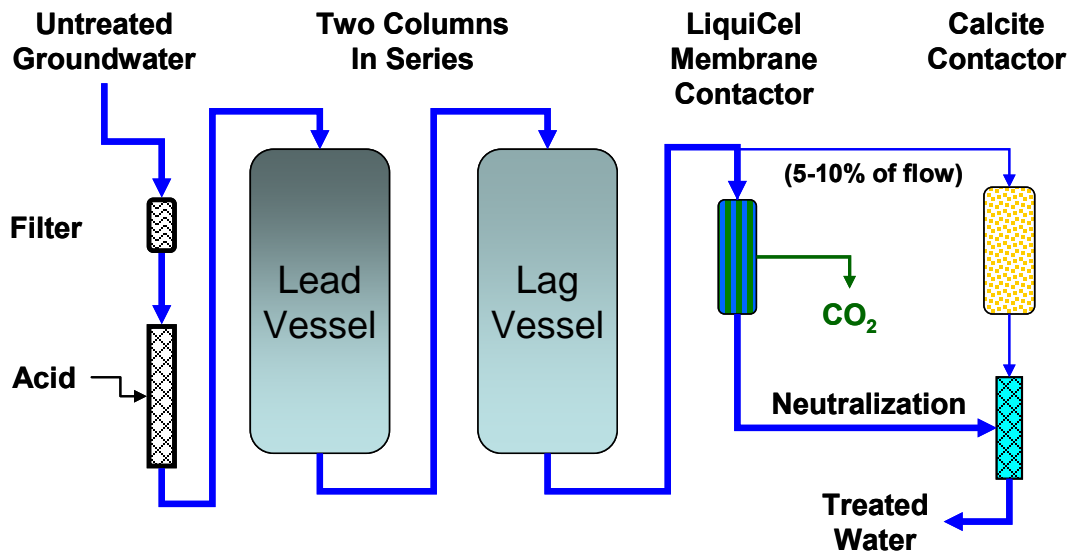

Figure 5-1. Process Configuration for Capital and O&M Cost Analyses

Resin regeneration will be accomplished in-situ. While the lead vessel is off-line for regeneration, the lag vessel will remain in service. Figure 5-2 shows the four basic regeneration operational steps.

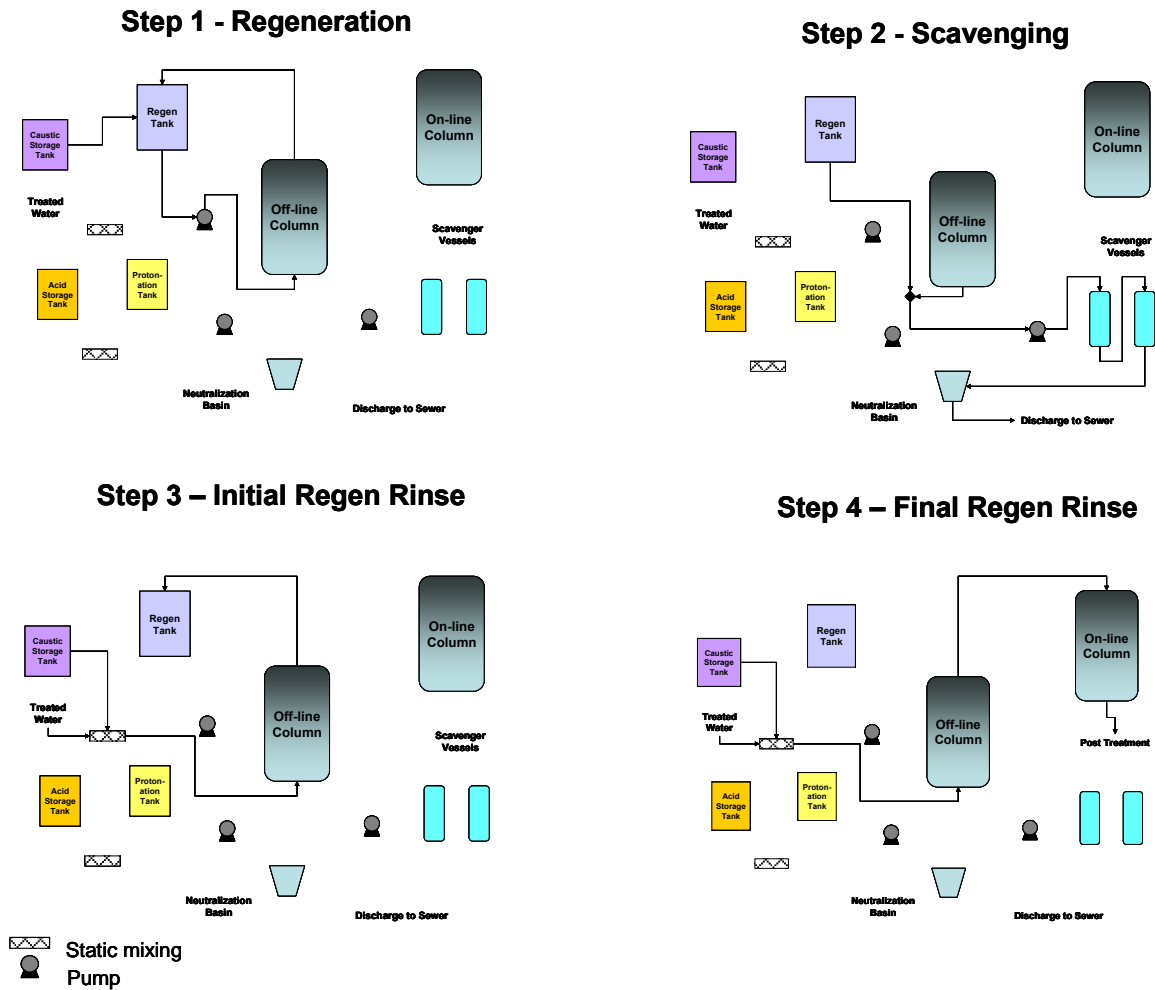

Figure 5-2. Regeneration Operations

Regeneration (Step 1) is accomplished in a batch operation where the regeneration water volume is limited to approximately two bed volumes. Regeneration is initiated countercurrent (up) flow immediately after the lead vessel is removed from service and without draining groundwater. Sufficient caustic (sodium hydroxide) is metered into the regeneration tank to neutralize all resin exchange sites and achieve a pH greater than 12.0 in the ion exchange vessel effluent.

Spent regenerating solution is drained from the ion exchange vessel and pumped from the regeneration tank into the scavenger ion exchange system (Step 2). The scavenger ion exchange system must be large enough to minimize the frequency of resin replacement and minimize the time to treat each batch of spent regenerating solution. Two, 60 ft³ transportable ion exchange vessels operated in series (lead-lag) are sufficient for this task. Strong base anion resin Purolite

A-530E will be used to scavenge perchlorate from the concentrated spent regenerating solution. The treated regenerating solution will be neutralized and discharged to sewer.

A pH 9 rinse is necessary to remove residual perchlorate from the resin before protonation. The rinse water will be prepared by on-line injection and mixing of caustic into a slipstream of treated water. The total rinse volume will be 24-36 bed volumes. The first two bed volumes of this rinse is pumped into the empty regeneration tank and retained for use in the subsequent regeneration (Step 3). The remainder of the rinse will be pumped to the pretreatment system for subsequent perchlorate treatment by the online column (Step 4). This approach eliminates discharge of rinse water.

The regeneration process is completed by ionizing or protonating the resin according to the two operational steps shown in Figure 5-3. After the pH 9 regeneration rinse is completed, protonation is accomplished by adding a metered amount of sulfuric acid to a protonation tank and circulating the solution through the resin bed (Step 1). The pH of the solution returning from the resin should remain below ~4.3. A brief (6-8 bed volume) rinse at pH 4 is necessary to prevent a high sulfate excursion (>500 mg/L MCL) in the treated water (Step 2). The protonation rinse may be discharged after neutralization. After the rinse is complete, the vessel is returned to service in the lag position.

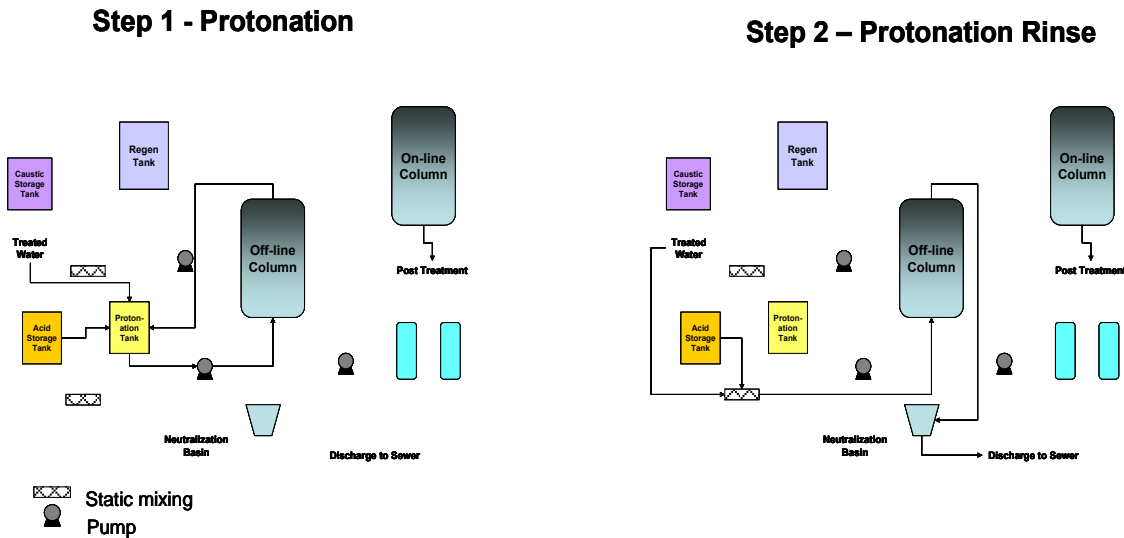

Figure 5-3. Protonation Operations

5.1.1.2 Design and Operating Basis

The design and operating basis for developing cost data is summarized in Table 5-1. A treatment rate of 1000 gpm was selected to permit direct comparison to ion exchange systems that typically treat 1000 to 2000 gpm per treatment train. A conservative treatment capacity of 9700 bed volumes was established based on pilot demonstration performance using Purolite D-4170 resin. Treatment capacities up to 50% higher can be obtained for water with lower nitrate concentrations based upon the isotherm testing and demonstration data generated during the

demonstration at Redstone Arsenal. The scavenger resin capacity is based on tests conducted that simulated 15 to 20 ppb perchlorate in the groundwater. Purolite A-530E resin was selected as the most economical scavenger resin from four candidates tested, including PWA2, A600 and A-520E. A summary of this cost analysis is provided in Appendix D. Higher perchlorate concentrations in the groundwater will result in higher loading capacities for the scavenger resins.

Table 5-1. Summary of Design and Operating Bases

Parameter	Concentration
Treatment rate, gpm	1000
Bed volumes (BV) per hour	24
gpm/ft ³ of WBA resin	3
Groundwater Composition	
Perchlorate, mg/L	0.02
Nitrate, mg/L as NO ₃	30
Sulfate, mg/L	30
Alkalinity as CaCO ₃ , mg/L	150
Treated water composition	
Perchlorate, mg/L	<0.001
Alkalinity as CaCO ₃ , mg/L	30
WBA resin treatment capacity, BV	9700
Scavenger resin capacity, meq/L	250

5.1.1.3 Major Equipment

Table 5-2 provides a summary of major equipment requirements and cost. Capital costs were derived from a budgetary cost estimates provided by A&Es and equipment vendors.

**Table 5-2. Type and Quantity of WBA System Equipment, and 2007
 Budgetary Cost Estimates**

Vessels	Quantity	Gallons	Total cost
Acid storage tank w/containment	1	6000	\$ 10,000
Caustic storage tank w/containment	1	3000	\$ 7,000
Regeneration tank w/containment	1	6000	\$ 10,000
Protonation tank w/containment	1	1500	\$ 5,000
Dilute acid feed tank	1	300	\$ 1,500
Neutralization tank/basin	1	500-1000	\$ 3,000
Pumps	Quantity	Head (ft)	
Acid and caustic meter/transfer pumps	8	100	\$ 16,000
Regeneration pump	1	100	\$ 12,000
Protonation pump	1	100	\$ 12,000
Scavenger transfer/drain	1	60	\$ 10,000
Equipment	Quantity	Unit	
Ion exchange vessels	2	10 ft dia.	\$ 200,000
Calcite contactor	1	100 gpm	\$ 30,000
LiquiCel Membranes	6	3 trains	\$ 60,000
Vacuum pump for membranes	1	30 SCFM	\$ 10,000
Bag filter (10 microns)	1	1000 gpm	\$ 10,000
Static mixing elements - 1,000 gpm	2	pre & post	\$ 20,000
Static mixing elements - 100 gpm	2	regen	\$ 10,000
Transportable scavenger vessels	3	30 ft ³	\$ 10,500
PLC and I/O interface panels	1		\$ 60,000
Motor control panels	1		\$ 60,000
pH controllers	10		\$ 50,000
Control valves	2		\$ 80,000
Subtotal			\$ 687,000
Equipment contingency (10%)			\$ 68,700
Estimated Freight & Tax (15%)			\$ 103,050
Equipment Capital Cost Estimate:			\$ 858,750

5.1.2 Operating and Maintenance Cost

5.1.2.1 O&M Cost Components

The primary O&M cost components are acid and caustic consumed in pretreatment, post treatment, and regeneration operations. Sulfuric acid (H₂SO₄) is the least expensive and safest strong acid to use for pretreatment and for resin protonation after caustic regeneration. However, hydrochloric acid (HCl) may be used without major cost impact for treating low-alkalinity (<50 mg/L) groundwater, or for scenarios that result in infrequent regeneration (>5000 BV treatment capacity). Sodium hydroxide is the least expensive and most efficient caustic to use for resin regeneration. In addition, high concentrations of sodium salts that result from the regeneration process will not cause precipitation or scaling problems, which could be the case if other caustic compounds were used for regeneration (i.e. potassium hydroxide).

Calcite and sodium hydroxide were used in the cost evaluation for post treatment neutralization, which is required to restore pH and residual alkalinity for drinking water applications. Other caustic compounds, such as soda ash (Na_2CO_3) may be used for post treatment. Carbon dioxide stripping was accomplished using Liqui-Cel membranes. Electricity consumption and membrane replacement were considered in the cost analysis.

The WBA resin ion exchange treatment process is designed to eliminate the need for additional pumping operations. The cost for pumping water to the system is common to any pump and treat system and, therefore, was not included in this cost analysis. The power requirement for controls and for the small acid and caustic pumps used in this process will also be minimal. The power required for regeneration pumps will be significant; however, these pumps will operate intermittently with an anticipated duty cycle of less than 10-15%.

The cost of treating spent regenerating solution is included in the cost evaluation. For drinking water applications, this cost includes the cost for scavenger resin replacement and incineration. Scavenger resin vessels are small (30 ft^3), transportable vessels that will be purchased as part of the system equipment but will be serviced by a third party. Spent regenerating solution from remediation of groundwater with high concentrations of perchlorate ($>500 \text{ ppb}$), may be more economically treated using a CSTR anoxic biodegradation process.

A full-scale ion exchange process will be fully automated – being controlled by a PLC – and require little labor. However, some labor will be required for maintenance; collecting samples; monitoring the receipt of acid, caustic, and scavenger resin; monitoring and evaluating system performance; and monitoring resin regeneration (~once every 2 weeks). Average labor requirement is estimated to be 5 hours per week.

Macroporus styrene divinylbenzene WBA resin can maintain performance for over five years in industrial applications that require daily regenerations. Regeneration frequency for drinking water and remediation applications are predicted to be no more than 30 times per year based on pilot performance. Therefore, WBA resin life for groundwater treatment applications is predicted to be seven years.

5.1.2.2 O&M Cost Basis

Table 5-3 provides a summary of the cost bases used for the major O&M costs. Chemical costs are based on quotes for bulk tank truck delivery to a southern California site. Scavenger resin cost includes disposal and servicing costs for Purolite A-530E. WBA resin cost is the current market price for commercially available Purolite D4170 resin.

Table 5-3. O&M Cost Basis

Description	Cost
Sulfuric acid, 96-98%	\$0.05/lb
Sodium Hydroxide, 50%	\$0.15/lb
Calcite	\$50/ton
Scavenger resin	\$180/ft ³
Weak base anion resin	\$500/ft ³
Resin handling and disposal	\$45/ft ³
Membrane replacement (every 3 years)	\$3000 ea.
Electricity	\$0.10/Kw-hr
Operator labor	\$75/hr

Table 5-4 provides a summary of Capital and O&M cost for a 1000 gpm drinking water treatment system. The normalized cost basis is dollars per acre-foot (AF) of water treated. This is the most appropriate basis for comparing high flow rate remediation and drinking water treatment systems. One acre-foot is equal to 325,851 gallons of water.

Purchased equipment cost in Table 5-4 was derived from the equipment unit and package costs and the quantities provided in Table 5-2. The other components of capital cost: site work and concrete, equipment installation and piping, electrical and instrumentation and controls installation, service facilities, engineering, construction expenses, and other indirect costs are budgetary estimates from a California A&E based on the purchased equipment cost for a southern California application. The cost estimate took into account the complexity and maturity of the unit operations involved. Startup and testing costs are estimates that depend on specific site requirements and performance demonstrated for other similar applications. Startup resin and chemical costs include the cost for the initial loading of weak base and scavenger resin, acid, caustic and calcite. Operating costs were derived from the cost bases provided in Table 5-3. Labor costs were based on 5 hr/wk for drinking water applications.

Table 5-4. Cost Summary

Cost Category	Cost Sub Category	Cost	
Capital Costs	Purchased equipment cost*	858,750	
	Site and concrete work	103,050	
	Equipment installation and piping	171,750	
	Electrical installation	128,813	
	Service facilities	85,875	
	Engineering	429,375	
	Construction expenses	171,750	
	Other indirect	85,875	
		SUBTOTAL:	2,035,238
		Startup and testing expenses	75,000
		Startup resin and chemicals	370,000
	TOTAL CAPITAL COSTS:	2,480,238	
Annual Operating Costs	Labor	\$ 19,500	
	Consumables**		
	Sulfuric acid	\$ 30,500	
	Sodium hydroxide	\$ 14,700	
	Calcite	\$ 2,600	
	WBA resin replacement & disposal	\$ 51,900	
	Scavenger resin replacement & disposal	\$ 12,500	
	Membrane replacement	\$ 6,000	
	Electricity	\$ 9,700	
		TOTAL OPERATING COSTS:	\$ 147,400
	Quantity treated, acre-feet (AF)	1590	
	Calculated unit O&M cost, \$/AF	\$ 92.69	

* Based on Table 5-2

** Based on Table 5-3

5.1.3 Economy of Scale

There is significant economy of scale for multiple-train systems larger than 1000 gpm. Regeneration and protonation tanks and pumps are underutilized in single-train, 1000-gpm ion exchange treatment processes. Since regeneration and protonation can be accomplished in less than two days, the duty cycle for this equipment is less than 15%. Therefore, the regeneration equipment for a 1000-gpm system could easily support the regeneration requirement for a five-train, 5,000-gpm treatment facility with little additional cost. A similar under-utilization

situation exists with the scavenger-resin treatment equipment. The equipment used for the 1000 gpm scenario would be adequate for a 5,000-gpm treatment system.

The pretreatment and post treatment operations would be performed in single pretreatment and post treatment systems regardless of the scale of the treatment operation. Pre- and post treatment equipment costs would be scaled proportional to the treatment requirement and the scaling exponent would be 0.5 or less. For large-scale applications (greater than 1000 to 2000 gpm), stripping towers will cost less to purchase and operate than membrane degassing equipment. The projected cost for a 4,000-gpm treatment system was developed and provided in Table 5-5. Labor and electricity will be less per unit of water treated which reduces the O&M cost for the 4000 gpm treatment system by nearly 10%.

Table 5-5. Capital and Operating Costs for a 4,000 gpm Treatment System

Category	Cost
Capital Cost	\$6.1 M
Operating Cost – per acre-foot	\$85

5.2 Cost Analysis

5.2.1 Major Cost Drivers

5.2.1.1 Groundwater Alkalinity

The amount of acid required for groundwater pretreatment to attain the pH necessary for good performance is directly proportional to groundwater alkalinity. Acid cost is \$1.03/acre-foot for every 10 mg/L of bicarbonate alkalinity in the groundwater based on sulfuric acid at \$0.05 per pound, delivered. In high pH water (>8), carbonate and hydroxide also contribute to the acid requirement. For the Fontana demonstration, the acid pretreatment cost was \$18.50 per acre-foot of water treated.

5.2.1.2 Perchlorate Concentration

Higher perchlorate concentration in groundwater directly affects the amount of scavenger resin required for drinking water applications, which increases cost. Since perchlorate is very concentrated in spent regenerating solution, much more perchlorate can be exchanged onto a strong-base scavenger resin than is removed by the primary ion exchange resin (weak base or strong base, single-use resin) used to directly treat the groundwater. In scavenger tests conducted to simulate treating 20 ppb water, Purolite A-530E resin was the most economical resin based on treatment capacity (~240 to 250 meq/L), replacement cost (\$180/ft³), and disposal cost (\$45/ft³). Based on a loading of 250 mg/L of perchlorate anion, the scavenger resin cost equates to about \$8 per acre-foot for a WBA process that removes 20 ppb of perchlorate from the groundwater.

5.2.1.3 Treated Water Alkalinity

Post treatment cost is directly proportional to the alkalinity required in the treated water. This demonstration showed that treated water with an alkalinity as low as 30 mg/L possessed acceptable properties, i.e., would not contribute to either scaling or corrosion in water distributions systems. However, scaling indices, such as the Langelier Saturation Index (LSI) are

a function of pH, temperature, calcium hardness, total dissolved solids, and alkalinity. Therefore, the post treatment approach is highly dependent on the water quality at each specific site. The approach taken for this cost analysis is to remove excess dissolved CO₂ by Liqui-Cel membranes and use calcite and caustic soda to achieve desirable treated water properties. Post treatment cost (caustic, calcite, electricity, membrane replacement) for this scenario equates to \$17/acre-foot based on 30 ppm of residual alkalinity (as CaCO₃). Alternative treatment approaches must be considered on a case-by-case basis and have the potential to reduce treatment cost.

5.2.1.4 Resin Regeneration Cost

Regeneration cost is dependent on resin treatment capacity, which is affected by other anions present in a specific groundwater. For a given water composition, treatment capacity is relatively independent of perchlorate concentration below 100 ppb because the perchlorate isotherms are linear between 1 and 100 ppb. In other words the quantity of perchlorate anion exchanged is directly proportional to the concentration of perchlorate anion in untreated water. The regeneration costs for the Fontana demonstration was less than \$5 per acre-foot of groundwater treated based on a treatment capacity of 9700 bed volumes. Isotherm tests have shown that regeneration costs could be up to 50% less for low-TDS groundwater with lower levels of nitrate, sulfate, and chloride.

5.2.1.5 WBA Resin Cost

Resin replacement cost is a major component of operating cost for several reasons. The best performing commercial resin produced by Purolite cost \$500 per cubic foot. While this resin is commercially produced, production rates are relatively low at this time. Higher production rates may lead to reduced cost. Perchlorate treatment systems for drinking water require a “multi-barrier” or two-stage, lead-lag treatment configuration. This configuration, in effect, doubles the amount of resin necessary for a treatment process. The annualized cost of resin replacement is about \$33 per acre-foot based on a 7-year service life. Resin replacement cost equates to about one third of the total O&M treatment cost.

5.3 Cost Comparison

Treatment costs in dollars per acre-foot (\$/AF) were evaluated for five different scenarios: 1) a WBA resin process for a 1000-gpm drinking water application that uses a scavenger resin to treat spent regenerating solution, 2) a WBA resin process for a 4,000-gpm drinking water treatment system, 3) the strong base anion (SBA) regenerable resin process (ISEP) using CalRes 2000 that is in operation at La Puente, CA, 4) the single-use, SBA resin process using PWA2 resin that is in operation at the Lincoln Avenue Water Company site, Altadena, CA, and 5) a proposed single-use, SBA resin process using CalRes 2100 or USF 9710 planned for Castaic Lake Water Agency, CA. The cost analysis is summarized in Table 5-6.

Table 5-6. Present Worth Cost Comparison for Perchlorate Removal by Various Ion Exchange Technologies

System:	WBA Regenerable	WBA Regenerable	SBA-ISEP Regenerable La Puente	SBA Single-Use Lincoln Ave.	SBA Single-Use Castaic Lake
Capacity, gpm	1000	4000	2500	2000	2400
Treatment vol, AF/yr	1591	6364	3978	3182	3818
Annual O&M Cost	\$ 147,400	\$ 532,000	\$ 1,950,000	\$ 1,084,124	\$ 940,000
Capital Cost	\$ 2,491,000	\$ 6,115,000	\$ 4,800,000	\$ 2,480,000	\$ 3,700,000
Interest Rate	6%	6%	6%	6%	6%
Plant Life	20	20	20	20	20
O&M Present Worth	\$ 1,690,666	\$ 6,101,998	\$ 22,366,346	\$ 12,434,817	\$ 10,781,726
Total Present Worth	\$ 4,181,666	\$ 12,216,998	\$ 27,166,346	\$ 14,914,817	\$ 14,481,726
Treatment Cost, \$/AF	\$ 131	\$ 96	\$ 341	\$ 234	\$ 190

Costs for the WBA scenarios are based on the data provided in Tables 5-4 and 5-5. Costs for the other scenarios were provided in a table published by CDPH dated October 14, 2004, and based on NASA Action Memorandums dated August 24, 2004, and April 19, 2006. The actual costs provided for the ISEP process were \$2.8M for capital and 1.6M for O&M. However, these costs did not include treatment or disposal of the perchlorate-contaminated, spent brine solution. ARA recently did an analysis under contract to the Baldwin Park Operable Unit (BPOU – controlling authority for La Puente) for brine treatment. The least expensive approach, biodegradation, would add \$2M in capital cost and \$350K in O&M cost. These costs were added to the values provided by CDPH and the sum used in Table 5-6. The Lincoln Avenue system is leased. An approximate estimate of capital cost was derived by multiplying the lease cost (\$9500/mo.) by the term (20 years) and adding known site improvement costs (\$200K). The Castaic Lake system is proposed.

A 20-year plant life and 6% interest rate were used to determine the net present value of the operating costs. The results of this analysis clearly show that water treatment cost for the WBA technology are less than 25% of current regenerable resin systems (ISEP), and approximately 50% of the least expensive single-use resin systems. It is important to note that the treatment cost for the WBA technology is only slightly dependent on capital cost. This is due to the large difference in operating cost of the WBA technology compared to current technologies.

6. Implementation Issues

6.1 Environmental Checklist

The host facility had the necessary permits for their current treatment process to remove perchlorate from drinking water. They are aware of the regulations that apply for perchlorate treatment and waste disposal and no other permits were required to for this demonstration.

6.2 Other Regulatory Issues

We worked closely with the host site and CDPH to develop a sampling and analysis plan that would provide the data necessary to obtain conditional acceptance of this technology for drinking water treatment. A formal request for conditional acceptance will be made to CDPH. A copy of this report and any additional data required by CDPH will accompany the request for conditional acceptance. Actual “approval” of the technology can only be obtained based on the design, engineering and testing of a full-scale implementation of the technology, which was beyond the scope of this effort.

6.3 End-User Issues

End-users for this technology include DOD facilities, formally used defense sites, and municipal drinking water systems that have been contaminated with perchlorate by past DOD operations. In addition to drinking water applications, the technology can be used by the DOD for pump-and-treat perchlorate remediation and to facilitate remediation of co-contaminants (such as VOCs) by enabling the removal of perchlorate before discharge or re-injection. The technology can also be applied to the treatment of wastewater generated by munitions manufacturing or demilitarization operations.

Implementation of this technology is straightforward. Commercial, large-scale, ion exchange equipment for WBA resin technology exists. Pretreatment and post treatment are simply pH control unit operations that are straight forward to design and engineer. Stripping tower design and engineering for CO₂ stripping are straight forward. Treatment of residuals by a scavenger ion exchange process is a proven technology. All processes operate at ambient temperature and low pressure (<~30 psig) and, therefore, present no unique engineering challenges or hazards.

The issues of primary concern for user acceptance are; 1) the perception of operational complexity, 2) the need for acid and caustic on site, and 3) the need for a part-time operator. The regenerable nature of this ion exchange technology is by definition more complex than single-use resin technology, will require use of regeneration chemicals on site, and will require an operator. However, treatment systems can be designed to operate with little operator oversight. For instance, regeneration cycles can be automatically initiated and executed. End user concerns may be offset for applications where water is highly contaminated, where regenerable ion exchange technologies are already in use, or where co-contaminants, such as nitrate, arsenic, or chromium, create the need for a regenerable ion exchange process.

6.4 Lessons Learned

During this drinking water treatment demonstration, there were several lessons learned regarding process operations as well as analyses needed to provide data for regulatory acceptance. The following list summarizes these lessons.

Process Operations:

- **Recycling of the regeneration rinse:** It was demonstrated that rinse water generated during the regeneration process could be recycled to the front of the system for treatment. Recycling and treatment of the rinse water was done successfully and without negative impact to the on-line treatment process (i.e. no perchlorate leakage). The benefits of rinse water recycling were: 1) the ability to conduct a thorough rinse, which eliminated perchlorate bleed after regeneration, and 2) no generation of perchlorate contaminated rinse water.
- **Effectiveness of membrane degassing, air stripping, and calcite treating for post-treatment:** It was demonstrated that a combination of air stripping, calcite treatment, and neutralization, or membrane degassing, calcite treatment, and neutralization are very effective post treatment operations that reduce treatment costs while restoring pH and alkalinity of treated water to acceptable levels. Treated water quality could be controlled to achieve a neutral LSI with alkalinity reduced to as low as 27 mg/L.

Regulatory Lessons:

- **Low-level perchlorate analyses:** For regulatory acceptance by CDPH, in addition to EPA Method 314.0, it was recommended to analyze for perchlorate using “low-level” detection methods such as IC/MS/MS or LC/MS/MS. These methods can detect perchlorate to parts per trillion levels in drinking water. Low-level detection methods were conducted by a certified laboratory during each test period to verify perchlorate removal and to demonstrate that perchlorate was not leaking during treatment of recycled rinse water. It is important to budget accordingly to include these analyses, because they can be up to 3.5 times more expensive than the typical IC method using EPA 314.0.
- **Nitrosamine analyses:** In ion exchange treatment processes, nitrosamine compounds have become an issue of concern to California regulators. For this demonstration, CDPH representatives recommended analyzing for nitrosamines including NDEA, NDMA, NDBA, NDPA, NMEA, NMOR, NPIP, and NPYR. The primary sampling times recommended were immediately after initiating the demonstration with virgin resin (within treating five bed volumes), at the conclusion of a test period, and after a regenerated column was placed on-line. It is important to budget for these analyses and to verify that the certified laboratory selected has the capability to meet the detection limits desired by CDPH (down to 2 ppt for some analytes).
- **Drinking Water Supply Permit (DWSP) approval process:** To obtain permit approval for a new technology for drinking water requires completion of system design, engineering, and construction; preparation of engineering packages that include pilot test data; and testing and reporting of the full-scale system performance. This requires very close coordination with CDPH and local drinking water purveyors. Air and water discharge permits may also be necessary to obtain the DWSP. Water cannot be produced for consumption until after the DWSP is issued.

7. References

- Boodoo, Francis. The Purolite Company. (610) 668-9090. fboodoo@puroliteusa.com.
- Clesceri, Lenore, S., Eaton, Andrew D., Greenberg, Arnold E. 1997. Standard Methods for the Examination of Water and Waste Water 20th Edition.
- Collins, Heather. CDPH Region V Regional Manager. (909) 383-4328.
HCollin2@dhs.ca.gov
- Helfferrich, Friedrich. 1995. Ion Exchange.
- Kieth, Lawrence H. 1992. EPA's Sampling and Analysis Methods.
- McCarthy, Sean. CDPH San Bernardino District Engineer. (909) 383-4328.
smccarth@dhs.ca.gov
- Schweitzer, Philip A. 1979. Handbook of Separation Techniques for Chemical Engineers.

8. Points of Contact

POINT OF CONTACT Name	ORGANIZATION Name Address	Phone/Fax/Email	Role in Project
Dr Andrea Leeson	ESTCP 901 N. Stuart Street, Suite 303 Arlington, VA 22203	703-696-2118 703-696-2114 fax andrea.leeson@osd.mil	Technical Project Manager
Mr. Bryan Harre	Navy Representative, 1100 23rd Avenue Port Hueneme, CA 93043	805-982-1795 805-982-4304 fax bryan.harre@navy.mil	DOD Representative
Mr. Edward Coppola	ARA 430 W. 5th St, Ste 700 Panama City, FL 32401	850-914-3188 850-914-3189 fax ecoppola@ara.com	Technical Manager
Ms. Andrea Davis	ARA 430 W. 5th St, Ste 700 Panama City, FL 32401	850-914-3188 850-914-3189 fax adavis@ara.com	Project Manager
Mr. Steve Baxley	ARA 430 W. 5th St, Ste 700 Panama City, FL 32401	850-914-3188 850-914-3189 fax sbaxley@ara.com	QA Manager
Mr. Robert Girvin	ARA 430 W. 5th St, Ste 700 Panama City, FL 32401	850-914-3188 850-914-3189 fax rgirvin@ara.com	QA/QC Coordinator
Mr. Chris Diggs	Fontana Water Company 16803 Spring Street Fontana, CA 92335	909-822-2201 cdiggs@fontanawater.com	Fontana Water Site- Coordinator
Ms. Heather Collins	CDPH Drinking Water Field Operations Branch 464 W. 4 th Street, Ste 437 San Bernardino, CA 92401	909-383-4328 909-383-4745 fax hcollin2@dhs.ca.gov	CDPH Representative

Appendix A

Site Map of Plant F17

at the

Fontana Water Company – Fontana, CA

March 30, 2006

**ESTCP PROJECT: ER-0312
ARA PROJECT: 16623 Phase 3**

Appendix B

Quality Assurance Project Plan Followed during the ESTCP Field Demonstration

at

Fontana Water Company – Fontana, CA

Prepared on June 1, 2006

**ESTCP PROJECT: ER-0312
ARA PROJECT: 16623 Phase 3**

1. Project Description and Objectives

1.1 Purpose of Study

Applied Research Associates, Inc., (ARA) was selected by the Environmental Security Technology Certification Program (ESTCP) to evaluate and demonstrate a low-cost, regenerable ion exchange process for removing perchlorate from groundwater. A regenerable, perchlorate-selective, weak-base-anion (WBA) resin process was developed for this demonstration.

The demonstration was conducted at Redstone Arsenal, located near Huntsville, Alabama. The demonstration was performed over 15 weeks during which treatment rates of 12, 18, and 24 bed volumes per hour (1.5, 2.25, and 3.0 gpm/ft³ of resin, respectively) were evaluated. Well RS498, a six-inch extraction well, was selected as the groundwater source for the demonstration. Anion concentrations of the well were as follows: 1500 to 2200 ppb perchlorate; 4 ppm nitrate (as nitrate); 3 ppm sulfate; 4 ppm chloride, and 150 ppm bicarbonate. Performance of the weak base anion (WBA) resin technology was assessed by collecting and analyzing groundwater samples before and after treatment. Five columns were regenerated to characterize regeneration efficiency. The spent regenerating solutions from these tests were used in perchlorate destruction and scavenging evaluations.

Results of the demonstration at Redstone Arsenal confirmed that perchlorate was reduced in the contaminated groundwater from >1500 ppb to below the method detection limit (4 ppb) for EPA Method 314.0. Regeneration of WBA resin was effectively and efficiently accomplished. The volume of spent regenerating solution was limited to less than 0.05% of the volume of water treated. Two treatment processes for the spent regenerating solution were demonstrated including biodegradation and a zero-discharge approach using strong base anion (SBA) scavenger resin. Both processes were effective in destroying or removing perchlorate to below the method detection limit. The regenerable WBA resin technology proved to be up to 50 times more efficient than brine-regenerable processes that use SBA resins. In addition, O&M costs are projected to be less than \$100 per acre-ft.

As a result of the successful demonstration at Redstone Arsenal, ESTCP requested that this technology be demonstrated for drinking water treatment in California. ARA's existing ESTCP contract with U.S. Army Corps of Engineers was modified to add this task with an effective date of January 17, 2006.

1.2 Site Description

To achieve these objectives, a field demonstration evaluating this technology will be conducted at a drinking water utility in California. The Fontana Water Company is a retail investor-owned utility company that provides water to approximately 160,000 residents, mainly in the City of Fontana. The company also serves portions of the cities of Rancho Cucamonga and Rialto. Two wells will be used for this demonstration. Well F17B was drilled in 1989 and produces 2500 gpm drinking water. Well F17C was drilled in 1994 and has a production rate of 3000 gpm. Water from these wells will be combined for treatment using the WBA pilot. Wells F17B and

F17C are each in operation and are currently treated for perchlorate using an on-site ion exchange process with non-regenerable, strong base anion resin. The treatment facility has a capacity of 6000 gpm.

1.3 Technology Description

Ion exchange using perchlorate-selective WBA resin is effective for treating perchlorate contamination in any surface, ground, or drinking water application. The primary advantages of ion exchange using WBA resin are the ease and simplicity of regeneration, the small volume of spent regenerating solution produced, the resulting lower O&M cost of regeneration, and the lower cost and ease of disposal of the spent regenerating solution. This ion exchange process takes advantage of the pH dependent nature of WBA resins. At low pH, functional groups on these resins have a positive charge (i.e. $R-NH_3^+$) allowing for anion exchange. However, at high pH, the resin functional groups lose a proton and are uncharged (i.e. $R-NH_2$) allowing for regeneration. The chemistry of WBA resin ion exchange is shown in Figure 1.

WBA resin in free-base form ($R-NH_2$) is ionized ($R-NH_3^+$) by protonating with acid (H^+):



Protonated resin removes anions (A^-) from aqueous streams:



Spent resin ($R-NH_3-A$) is regenerated by neutralizing with caustic ($NaOH$), which liberates anions and returns resin to the free-base form:



Figure A-1. Weak Base Anion Resin Chemistry

The ion exchange process using WBA resins is comprised of three unit operations: pretreatment, ion exchange, and degassing/post treatment. Spent resin must be regenerated and protonated before being placed back in service. The perchlorate in the spent regenerating solution will be scavenged using strong base anion resin. The perchlorate-free regenerating solution can then be discharge and the scavenger resin incinerated.

1.4 Project Objectives

The demonstration conducted at Redstone Arsenal confirmed that the ARA WBA resin technology performs very well for perchlorate removal and has the potential to reduce O&M cost to less than 50% of the most efficient ion exchange processes available. Based on the success of the Redstone demonstration, the primary objectives of this drinking water demonstration are to:

- Demonstrate WBA resin technology for drinking water treatment in California

- Acquire acceptance from the California Department of Public Health (CDPH), Drinking Water Field Operations Branch, to grant permit modification to include WBA resin ion exchange treatment process for drinking water applications
- Demonstrate “zero-discharge,” scavenger resin approach to treating spent regenerating solutions

Perchlorate-selective as well as non-selective ion exchange resins are currently used commercially for perchlorate removal from drinking water in California. However, current ion exchange processes that use strong base anion exchange resins have several liabilities. These liabilities include: 1) the high cost of resin replacement and incineration for non-regenerable (single-use), perchlorate-specific ion exchange systems; 2) large volume of contaminated brine residual generated by non-specific perchlorate regenerable systems; and 3) the difficulty and high cost of treating residuals. The technology proposed for this demonstration takes advantage of the performance of a regenerable, perchlorate-selective resin and addresses the liabilities associated existing, single-use and brine-regenerable ion exchange processes.

To achieve these objectives a demonstration of this novel WBA resin ion exchange technology will be conducted at Fontana Water located in San Bernardino County, CA. Drinking water wells expected to serve as the source water for this demonstration have a combined perchlorate contamination of 13 ppb. Fontana Water representatives are assisting by providing ARA with water quality characteristics of the available wells and providing site coordination support to use existing infrastructure such as power and water.

2. Project Organization and Responsibility

This section of the QAPP addresses the project organization and division of responsibilities amongst the parties involved in this project, which is being undertaken by ESTCP. The QA/QC functions have been organized to allow independent review of project activities. The overall assignment of responsibilities are discussed below and outlined in the organizational chart included as Figure A-2.

2.1 Overall QA Management Organization

The objectives of the quality assurance and quality control (QC) efforts for this program are to assess and to document the precision, accuracy, and adequacy of the process data developed during sampling, monitoring, and analysis. The following management responsibilities have been assigned as an inherent part of this process.

ARA project manager (Ms. Andrea Davis): The ARA project manager has the final responsibility for completing this project in accordance with the Program objectives and within the schedule and budget constraints. The ARA project manager also has the ultimate responsibility for the overall ARA technical effort. This includes the timely, cost-effective execution of all project activities. The ARA project manager will maintain communication with all interested parties. Subcontractors will immediately report any technical problems to the ARA project manager. The ARA project manager will apprise the ESTCP TPM of project status and discuss project development. The ARA project manager will distribute the final QAPP as approved by ESTCP to all personnel.

ARA Technical Lead (Mr. Edward Coppola): The ARA technical lead will provides technology guidance, demonstration system design and engineering, and operational support.

ARA QA Manager (Mr. Steve Baxley): The ARA QA Manager holds the overall responsibility for ESTCP QA activities. He will review the QAPP, evaluate the QC program for ARA and its subcontractors, and assure that the results of all QA/QC activities are properly incorporated, performed, and documented.

ARA QA/QC Coordinator (Mr. Robert Girvin): The ARA QA/QC Coordinator provides assistance in the generation and review of the QAPP and to ensure that data generated by subcontractors satisfies data quality and project objectives. The ARA QA/QC Coordinator reports directly to the ARA QA Manager and indirectly to the ARA project manager.

Fontana Water Company Representative (Mr. Chris Diggs): The site representative is responsible for coordinating on site activities with the project contractor (ARA). The site representative will communicate site specific health and safety and environmental requirements prior to execution of the field demonstration.

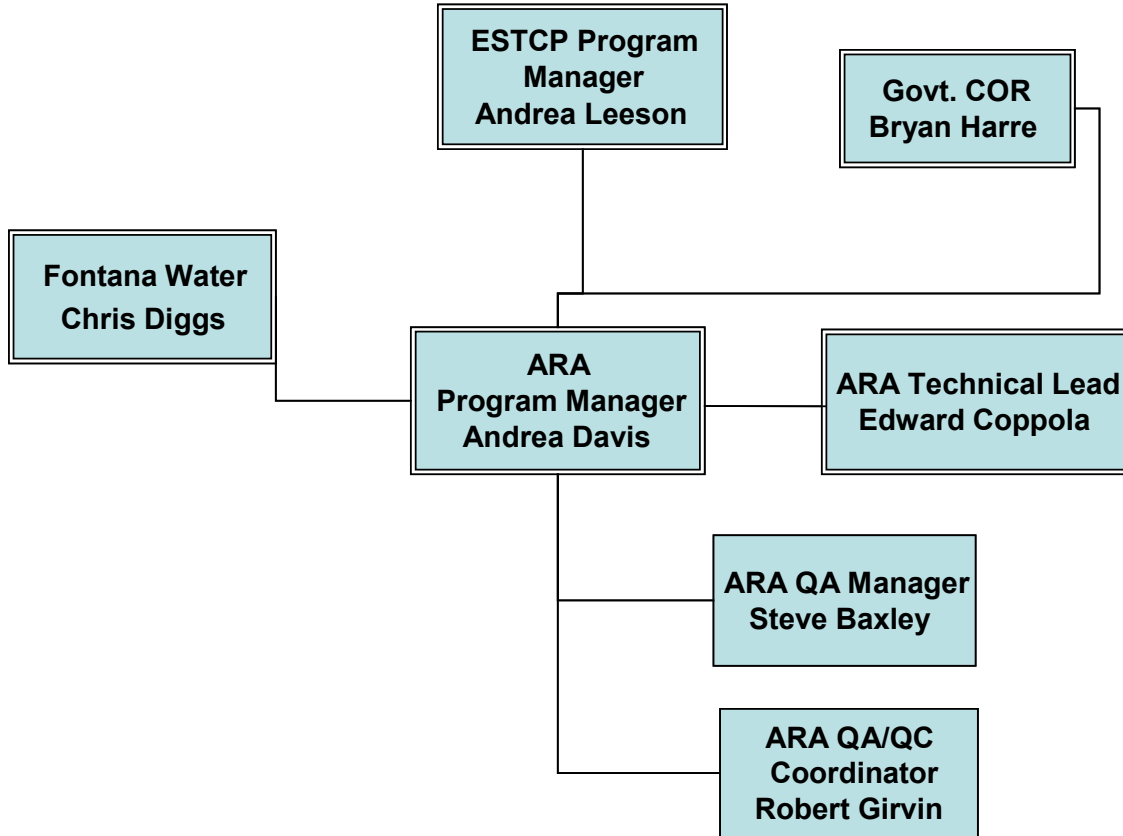

Figure A-2. Responsibility Organization Chart

2.2 Key Personnel Contact Information

POINT OF CONTACT Name	ORGANIZATION Name Address	Phone/Fax/Email	Role in Project
Dr Andrea Leeson	ESTCP 901 N. Stuart Street, Suite 303 Arlington, VA 22203	703-696-2118 703-696-2114 fax andrea.leeson@osd.mil	Technical Project Manager
Mr. Bryan Harre	Navy Representative, 1100 23rd Avenue Port Hueneme, CA 93043	805-982-1795 805-982-4304 fax bryan.harre@navy.mil	DOD Representative
Mr. Edward Coppola	ARA 430 W. 5th St, Ste 700 Panama City, FL 32401	850-914-3188 850-914-3189 fax ecoppola@ara.com	Technical Manager
Ms. Andrea Davis	ARA 430 W. 5th St, Ste 700 Panama City, FL 32401	850-914-3188 850-914-3189 fax adavis@ara.com	Project Manager
Mr. Steve Baxley	ARA 430 W. 5th St, Ste 700 Panama City, FL 32401	850-914-3188 850-914-3189 fax sbaxley@ara.com	QA Manager
Mr. Robert Girvin	ARA 430 W. 5th St, Ste 700 Panama City, FL 32401	850-914-3188 850-914-3189 fax rgirvin@ara.com	QA/QC Coordinator
Mr. Chris Diggs	Fontana Water Company 16803 Spring Street Fontana, CA 92335	909-822-2201 cdiggs@fontanawater.com	Fontana Water Site-Coordinator

3. Experimental Approach

To demonstrate this ion exchange technology using weak base anion (WBA) resin as an effective perchlorate water treatment process, a pilot system composed of three major unit operations was designed. The complete system includes units for pH pretreatment, ion exchange, and pH post-treatment. The process is depicted in Figure A-3.

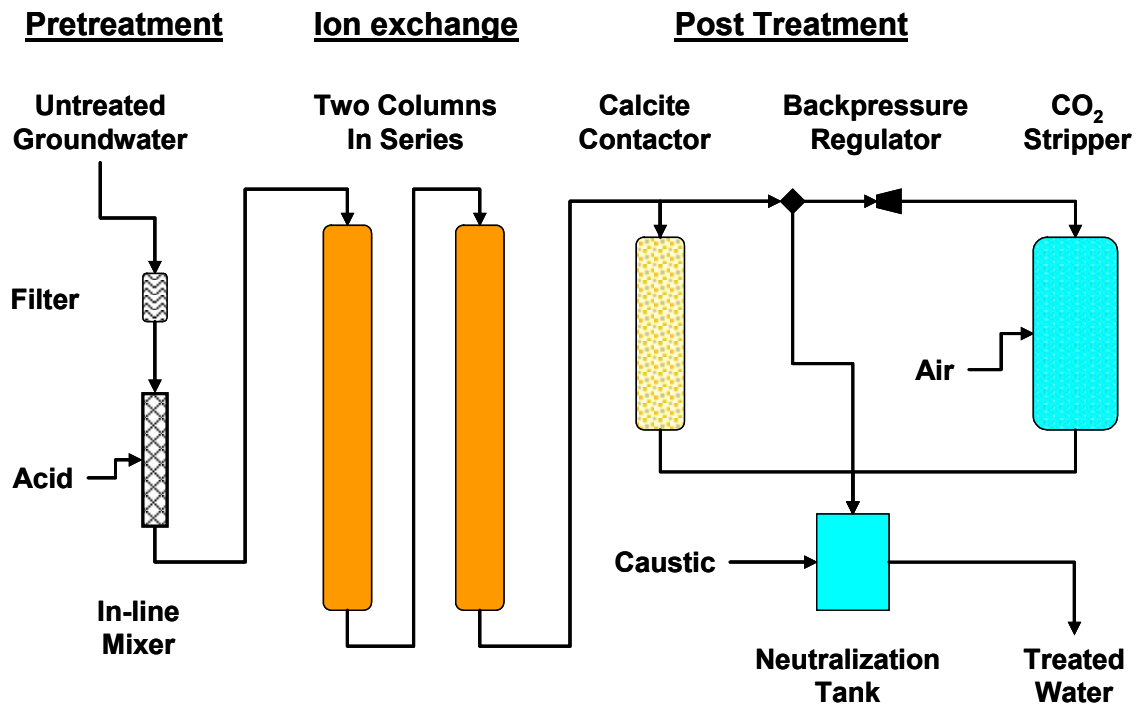

Figure A-3. Demonstration Process Flow Diagram

Pretreatment:

The function of pretreatment is to reduce the pH of the contaminated groundwater. Operational pH between 3 and 5 will prevent resin functional groups from being neutralized. The feed pH is typically maintained at 4.0 by addition of NSF certified sulfuric acid. Groundwater from the well head will be filtered and metered into the pressurized pH pretreatment system. This system consists of a pH controller, an acid feed system, and a circulation pump and a small mixing zone. The actual volume of the pressurized pretreatment system is approximately 4.6 liters. At 24 BV/hr feed rate (48 liters/hr water flow rate), the hydraulic residence time is 5.75 minutes. At an operating pH of 4.0, alkalinity present in the groundwater is rapidly converted to carbonic acid in equilibrium with carbon dioxide. A backpressure regulator, placed after the ion exchange columns, controls system operating pressure at 10-20 psig. System pressure keeps carbon

dioxide gas in solution as dissolved carbon dioxide and carbonic acid. The quantity of acid required for pretreatment is directly proportional on the alkalinity of the untreated water.

Ion Exchange:

Ion exchange is accomplished in two, clear-PVC ion exchange columns connected in series (lead-lag configuration). The ion exchange columns are 5 ft in height and have a 2-inch inside diameter. The ion exchange columns can be operated a resin bed depths between 30 and 40 inches, which is typical for commercial ion exchange systems. A 36-inch bed depth equates to 2-liters of resin. The ion exchange columns were purposely sized to permit direct scale up to commercial systems while minimizing the water flow rate required for the demonstration. When perchlorate breakthrough in the lead column exceeds 30 to 50% of the groundwater feed concentration, this column will be removed from the system for regeneration and the lag column will replace the lead column. The freshly regenerated column will be returned to the system in the lag position. This cycle will be repeated throughout the demonstration. Treated water will pass through a digital flow totalizer before post treatment to determine the volume of water treated.

Several WBA resins have been evaluated. Purolite D-4170 is the best performing resin evaluated to date and will be used for this demonstration. This is the same resin that was used for the Redstone demonstration.

Post Treatment:

Post treatment is conducted to strip excess dissolved CO₂, which reduces neutralization costs and to restore pH and alkalinity of the treated water to acceptable levels. Post treatment requirements are site specific and depend on corrosion or scaling potential of the groundwater. The post treatment system was designed to control the degree of carbon dioxide stripping and neutralization using sodium hydroxide and/or calcite to “dial in” treated water alkalinity and pH to the desired requirement. The treated water neutralization/holding tank has a residence time of approximately 4 hours, which provides ample time for equalization and neutralization.

Regeneration & Protonation:

Regeneration is accomplished on site by increasing the pH of the spent resin to neutralize the functional groups. The column being regenerated is isolated from the ion exchange process and regeneration accomplished by circulating up to 3 bed volumes (6 liters) of potable water through the resin bed for 2 hours or more. Sufficient caustic (sodium hydroxide) is added to the potable water to neutralize the resin exchange sites and maintain pH above 12.0. After the regeneration is complete, spent regenerating solution is drained from the column and held for subsequent treatment. A pH 9 rinse is conducted to remove residual perchlorate from the resin before protonation. The first three bed volumes (6 liters) of this rinse will be retained and used for the subsequent regeneration. This fraction of the rinse will be sampled and analyzed for perchlorate. Rinsing will continue at a low flow rate (~2 BV/hr) for approximately 16 hours (overnight). This will result in a total rinse volume of 30 to 35 BV. All but the first 6 BV of rinse is returned to the pretreatment system and treated in the ion exchange process.

After the rinse is complete, protonation is accomplished by decreasing the pH of the resin. Protonation is accomplished by circulating up to 3 bed volumes (6 liters) of perchlorate-free, potable water solution through the resin bed for 2 hours or more. Sufficient acid (H₂SO₄) is added to the water to protonate the resin exchange sites and maintain pH below 4.0. After the protonation is complete, the resin can be returned to service. The spent protonating solution may be recovered, reused, or neutralized and discharged.

Residuals Treatment:

A strong base anion resin will be used to scavenge perchlorate from the concentrated spent regenerant solution. This will be conducted on site so no perchlorate-containing effluent will be generated. The scavenger system consists of three small columns in series. Each scavenger column will contain enough resin (20 to 40 cc) to scavenge all of the perchlorate recovered from the regeneration from one or two ion exchange columns. After treatment of each batch of spent regenerant, or after the first scavenger column becomes saturated, the first scavenger column will be removed from service and a fresh column installed in the lag (third in series) position. The spent resin will be shipped to ARA’s Panama City, FL laboratory for analysis and disposal.

Experimental Design:

Six test periods are proposed for this demonstration as shown in the test matrix below. Each test period is defined as the period from initiation of flow through a new column in the lead position, until perchlorate breakthrough (30 to 50%) is observed, or the column is removed from service for regeneration. Breakthrough test 1 will be terminated when the first column (A) in the lead position exhibits breakthrough. Breakthrough test 2 will be terminated when the second column (B) in the lead position exhibits breakthrough. The number of regenerations per column is maximized and the duration of the demonstration minimized by using only two columns and by conducting short-cycle regeneration tests (tests 3 & 4). A short-cycle test is defined as a column that is regenerated before breakthrough is observed and after less than one week on line. The short-cycle tests will also be used to evaluate perchlorate removal efficiency at high specific flow rates (4 & 5 gpm/ft³). The flow rate for the last two tests (5 & 6) will be determined after evaluating performance of the first four tests.

Table A-1. Test Matrix

	Test 1	Test 2	Test 3	Test 4	Test 5	Test 6
Lead column	A	B	A	B	A	B
Lag column	B	A*	B*	A*	B*	A*
Regenerate	After BT**	After BT	After 1 wk	After 1 wk	After BT	After BT
Weeks on line	~4	~4	<1	<1	2-4	2-4
Flow (BV/hr)	24	24	32	40	24	24
Flow (gpm/ft ³)	3	3	4	4	3	3
CO ₂ strip (%)	100	90	80	80	TBD	TBD
Calcite (%)	0	10	20	0	TBD	TBD
NaOH (%)	0	0	0	20	TBD	TBD

* Column is returned to the lag position after regeneration

** BT → Breakthrough

4. Sampling Procedures

4.1 Pilot Field Demonstration

The collection of representative samples during execution of this project is vitally important to the success of project objectives. Sample collection during the field demonstration effort will include groundwater samples, pretreated groundwater, water following the lead and lag columns, and post treated water. The schematic shown in Figure A-4 lists the sampling locations of the pilot system. These samples will be analyzed by standard laboratory techniques for anions, general mineral and physical properties, and nitrosamines.

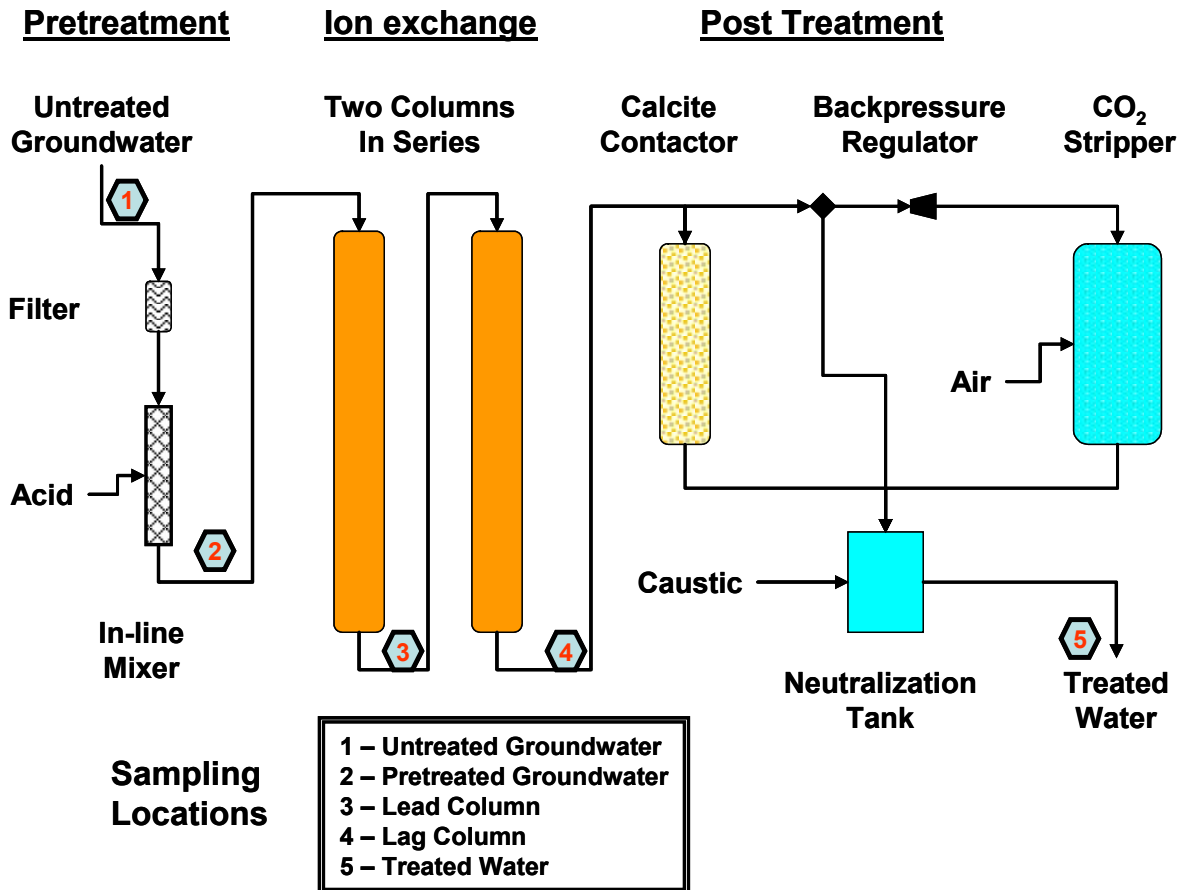

Figure A-4. Pilot System Process Schematic with Sampling Locations

4.1.1. Column Preparation

Two columns will be prepared for use throughout the field demonstration. Both columns will be loaded with exactly two liters of resin. The resin will be added to the columns as a slurry and preconditioned according to the procedures outlined in Attachment 1. These procedures include steps for loading and rinsing the resin, pre-protonation, regeneration, protonation, and a final rinse. A sample will be taken from each column at the completion of the final rinse for nitrosamine analysis by a certified laboratory.

4.1.2. Initial Start Up & Operation

Once the system is online, samples will be collected for analysis by ARA and/or a certified laboratory. For the test periods described in Table A-1, lists of parameters and methods, sample points, frequency of sampling, and an estimated number of samples collected are provided in Tables A-2, A-3, and A-4. The estimated number of samples collected does not include duplicates or QA/QC samples collected and analyzed in accordance with the QAPP. Operational data such as pH, flow rate, and pressure will be collected and recorded during each site visit in addition to being recorded and stored by a data acquisition system (at minimum, the data acquisition system will store data every hour). At least one trip blank and one duplicate sample will be included in each sample shipment to ARA and/or a certified laboratory for perchlorate analysis.

Table A-2. Sampling Summary for ESTCP Pilot Demonstration during Test Periods 1 & 2

Certified Laboratory				
Parameter	Sample Point	Sample Frequency	Method	#Samples Collected
Perchlorate	2 and 5	24 hour after startup and final	EPA 314.0 or by IC-MS/MS or LC-MS/MS	8
Anions (Chloride, Nitrate, & Sulfate)	2 and 5	24 hour after startup and final	EPA 300.1	8
General physical & mineral*	2 and 5	24 hour after startup and final and at any post-treatment condition change	Various (see Table A-6)	8
Nitrosamines**	1, 3, and 4	Influent at beginning of demonstration; Treated water sampled at start up (<24BVs); at one week; and after regeneration	EPA 521	9
Heterotrophic Plate Count	3 and 4	24 hour after startup and final	9215	8
Total Coliform	3 and 4	24 hour after startup and final	9221	8
ARA				
Parameter	Sample Point	Sample Frequency	Method	#Samples Collected
Perchlorate	1,2,3,4,5	Startup - 2, 20, and 100 bed volumes; normal operation - 3X per week	EPA 314.0	135
Anions (Chloride, Nitrate, & Sulfate)	1,2,3,4, 5	Startup - 2, 20, and 100 bed volumes; normal operation - weekly	EPA 300.1	55

*General physical and mineral parameters include alkalinity, hardness, color, turbidity, conductance, pH, TS/TDS, and metals (Ca, Cu, Fe, Mg, Mn, K, Na & Zn). Specific methods are listed in Table A-6.

** Nitrosamines include NDMA, NDEA, NDPA, NDBA, NMEA, NPIP, NYPR, NDPhA, NMOR

Table A-3. Sampling Summary for ESTCP Pilot Demonstration during Test Periods 3 & 4

Certified Laboratory				
Parameter	Sample Point	Sample Frequency	Method	#Samples Collected
Perchlorate	2 and 5	Final	EPA 314.0 or by IC-MS/MS or LC-MS/MS	4
Anions (Chloride, Nitrate, & Sulfate)	2 and 5	Final	EPA 300.1	4
General physical & mineral*	5	Final	Various (see Table A-6)	2
Nitrosamines**	None			
ARA				
Parameter	Sample Point	Sample Frequency	Method	#Samples Collected
Perchlorate	1,2,3,4,5	Startup - 2, 20, and 100 bed volumes; normal operation - daily	EPA 314.0	65
Anions (Chloride, Nitrate, & Sulfate)	1,2,3,4, 5	Startup - 2, 20, and 100 bed volumes; normal operation - 3 X per week	EPA 300.1	45

*General physical and mineral parameters include alkalinity, hardness, color, turbidity, conductance, pH, solids (TS/TDS), and metals (Ca, Cu, Fe, Mg, Mn, K, Na & Zn). Specific methods are listed in Table A-6.

** Nitrosamines include NDMA, NDEA, NDPA, NDBA, NMEA, NPIP, NYPR, NDPhA, NMOR

Table A-4. Sampling Summary for ESTCP Pilot Demonstration during Test Periods 5 & 6

Certified Laboratory				
Parameter	Sample Point	Sample Frequency	Method	#Samples Collected
Perchlorate	2 and 5	24 hour after startup and final	EPA 314.0 or by IC-MS/MS or LC-MS/MS	8
Anions (Chloride, Nitrate, & Sulfate)	2 and 5	24 hour after startup and final	EPA 300.1	8
General physical & mineral*	2 and 5	24 hour after startup and final and at any post-treatment condition change	Various (see Table A-6)	8
Nitrosamines **	3 and 4	Final for test period 5; Startup for test period 6	EPA 521	4
Heterotrophic Plate Count	3 and 4	24 hour after startup and final	9215	8
Total Coliform	3 and 4	24 hour after startup and final	9221	8
ARA				
Parameter	Sample Point	Sample Frequency	Method	#Samples Collected
Perchlorate	1,2,3,4,5	Startup - 2, 20, and 100 bed volumes; normal operation - 3X per week	EPA 314.0	135
Anions (Chloride, Nitrate, & Sulfate)	1,2,3,4, 5	Startup - 2, 20, and 100 bed volumes; normal operation - weekly	EPA 300.1	55

General physical scan includes pH, color, turbidity, total alkalinity, total hardness, conductance, TDS, calcium, copper, iron, magnesium manganese, potassium, sodium, and zinc.

** Nitrosamines include NDMA, NDEA, NDPA, NDBA, NMEA, NPIP, NYPR, NDPhA, NMOR

Processes for regeneration and residual treatment are described in section 3. Table A-5 provides a sampling summary for the effluents of regeneration and residual treatment processes. Before initiating any of these processes, the influent will be analyzed to determine initial perchlorate and other anion concentrations as well as pH.

Table A-5. Sampling Summary for Regeneration and Residual Treatments

ARA				
Process	Parameter	Sample Frequency	Method	#Samples Collected
Regeneration	Perchlorate	Final Composite(s) and grab sample of final rinse.	EPA 314.0	18
	Anions	Final Composite(s) and grab sample of final rinse.	EPA 300.1	18
Residual Treatment	Perchlorate	Following each column (3) and final composite.	EPA 314.0	24
	Anions	Following each column (3) and final composite.	EPA 300.1	24

Table A-6 lists the minimum sample volume, holding time, and preservative for each analytical method proposed for use during the field demonstration.

Table A-6. Sample Parameters, Volume, Preservative Requirements and Hold Times

Parameter	Matrix	Method	Volume	Container & Preservation	Hold Time
Perchlorate	Aqueous	EPA 314.0	100 ml	HDPE, Cool 4°C	28 days
Anions	Aqueous	EPA 300.1	100 ml	HDPE, Cool 4°C	28 days
Turbidity	Aqueous	SM 2130B	100 ml	HDPE, Cool 4°C	48 hrs
Color	Aqueous	SM 2120B	50 ml	HDPE, Cool 4°C	48 hrs
Hardness	Aqueous	SM 2340	100 ml	HDPE, Cool 4°C, pH<2, HNO ₃	6 month
Alkalinity	Aqueous	SM 2320B	100 ml	HDPE, Cool 4°C	14 days
Conductance	Aqueous	SM 2520	100 ml	HDPE, Cool 4°C	28 days
pH	Aqueous	SM 4500	5 ml	N/A	Immediate
Solids (TS/TDS)	Aqueous	SM 2540	100 ml	HDPE, Cool 4°C	7 days
Metals (Ca, Cu, Fe, Mg, Mn, K, Na, Zn)	Aqueous	SM 3125	200 ml	HDPE, pH<2, HNO ₃	6 month
Nitrosamines*	Aqueous	EPA 521	1000 ml	glass, Cool 4°C, 80-100mg Na ₂ S ₂ O ₃	14 days
Heterotrophic Plate Count	Aqueous	SM 9215	100 ml	Presterilized plastic bag, Cool 4°C	16 hours
Total Coliform	Aqueous	SM 9221	100 ml	Presterilized test tubes, Cool 4°C	16 hours

* Nitrosamines include NDMA, NDEA, NDPA, NDBA, NMEA, NPIP, NYPR, NDPhA, NMOR

4.2 Sample Identification, Custody and Transport

4.2.1 Sample Identification

Samples collected in the field will be labeled clearly and legibly. Each sample will be labeled with a unique sample identification number that identifies characteristics of the sample as follow:

Characteristic:	(i)	-	(ii)	-	(iii)	-	(iv)
	Sample ID		Date		Time		Sampler
Example:	1/A		01/01/05		1104		jsb

Where:

Sample ID - 2 characters identifying task (1, 2, 3) and the sample point (A, B, C)

Date - date sampling occurred: (mm/dd/yr)

Time - time sampling occurred (24-hr clock)

Sampler - 3 alpha characters that identifies the sampler (initials)

4.2.2 Preparation of Bottles for Shipment

Preparing bottles for shipment will be conducted in the following manner:

- Label bottles with prepared labels (see 4.2.1) and secured with tape.
- Record the samples on the Chain of Custody forms (see 4.2.3).
- Place sample containers in plastic zip-loc, bubble-pack bags.
- Prepare an empty, clean insulated cooler by removing all existing labels.
- Place 3-4 ice packs in a garbage bag at the bottom of the cooler. Place a second garbage bag inside the first and fill with the sample bottles. Seal the bag with the samples with strapping tape. Add additional bags of ice to the first bag to surround the samples. Seal the outer bag with strapping tape and a custody seal.

4.2.3 Sample Custody

Samples will be retained at all times in the field crew's custody. To accommodate the field schedule, samples will be shipped to the appropriate laboratory as soon as possible by an overnight courier. If samples are collected over the weekend, they will be kept inside so they are protected from direct sunlight and must be shipped on the following Monday. The temperature of all samples shipped will be as close to 4°C as possible.

Sample custody seals will be placed on the outside of each individual container or wrapped around each plastic bag inside the shipment cooler(s). Each custody seal will be attached in manner to allow detection of unauthorized tampering of samples after collection and prior to analysis. The date and initials of the sampler will be recorded on each seal.

Chain of custody (COC) forms will be initiated at time of sample collection. These forms will ensure that all collected samples are properly transferred over from the sampler to the laboratory sample custodian. The following information will be provided when filling out the COC forms (some sections may not be applicable during the field demo):

Table A-7. Chain of Custody Information

Project Name	Enter the project name as it is listed on the contract status summary sheets distributed periodically.
Facility Name, Address, & Phone #	Enter the complete name and correct mailing address for the Demonstration Test Facility.
Field Contact and Phone Number	Enter the complete name of the field sample custodian and a phone number where they can be reached in the field.
Project Manager and Phone Number	Enter the complete name of the project WAM and the phone number where they can be reached.
Laboratory Name, Address, Contact, and Phone Number	Enter the complete name of the laboratory and the ship to address. Also include the contact at the facility and the phone number where they can be reached.
Shipping Method and Air Bill No.	Enter the name of the overnight carrier service used to ship the samples and the complete Air Bill No.
Matrix	Enter the type of sample matrix (i.e., solid, liquid, gas).
Sample Number	Enter the sample identification number.
Date / Time	Enter the data and time of actual sample collection
Parameters	List the parameters to be analyzed. If abbreviations for parameters are used, they need to be explained somewhere on the sheet. Also provide further details for logging in samples
Number of Containers	Enter the total number of containers for a given location.
Observations	Enter any miscellaneous observations or comments to explain sample (i.e. color).
Comments, Special Instructions	For sample handling and analysis. QC samples will be identified here.
Relinquished By:	Sign and enter the complete name of the sample custodian who filled out the chain-of-custody form. Also enter the date and time the form was completed.

When all line items are completed or when the samples are picked up, the sample collection custodian will sign and date the form, list the time, and confirm the completeness of all descriptive information contained on the form. Each individual who subsequently assumes responsibility for the sample will sign the COC form and provide the reason for assuming custody. The field COC terminates when the laboratory receives the samples. The field sample custodian should retain a copy of the COC form for program files.

The COC records will accompany the shipment, or transfer of samples. For site characterization samples being shipped, these documents will be enclosed in a waterproof plastic bag and taped to the underside of the ice chest lid. For shipment of multiple coolers, COC records are prepared separately for the contents of each cooler separately. Each container prepared for shipment will be securely taped shut. Reinforced or other suitable tape (such as strapping tape) will be wrapped around the ice chest. COC seals will be affixed on each ice chest prepared for shipment. When selecting sample shipment modes, field personnel will ensure that the sample will not exceed allowable holding times for individual analyses. When a commercial common carrier is used to ship samples, all samples will be shipped "Priority One/Overnight." When using the commercial carrier, Federal Express, air bills will be completed and attached to the exterior lids of the containers. Samples collected during the field demonstration for analysis by ARA's in-house laboratory will be shipped to:

ARA Associates
430 West 5th Street, Suite 700
Panama City, Florida, 32401
Phone #: 850-914-3188

Field demonstration samples not analyzed by ARA's in-house laboratory will be shipped to the following address:

Associated Laboratories
806 N. Batavia
Orange, CA 92868
Attn: Sample Custodian
Phone #: 714-771-6900

Any discrepancy between the samples and the chain-of-custody information, any broken or leaking sample bottles, or any other abnormal situations will be reported by the laboratory to the ARA project manager. The ARA project manager will regularly contact the laboratory during the demonstration to ensure samples are being shipped and analyzed in accordance with QAPP specifications. If required, corrective action options will be discussed and implemented. Notations of the problem and resolution will be made in a laboratory Non-Conformance Record and documented in the analytical report

narrative. The information required to be recorded by the sample custodian includes the following:

- Client identifying number or description;
- Project number;
- Date of receipt;
- Client name;
- Analyses required; and
- Condition of sample

Once samples are in the custody of the laboratory, sample integrity will be maintained through the use of locked storage areas. Removal of samples will be documented on the sample log-in sheet or on the computer system. When samples are required for preparation and/or analysis, the sample custodian or designee will distribute the requested samples to the appropriate analysts. An internal COC form will be signed by the individual to whom the samples are relinquished. Documentation in the laboratory will be initiated by the sample custodian who receives the sample, assigns the laboratory numbers (or uses sample ID numbers), and tracks the samples internally.

4.3 Field Documentation

All handwritten documentation must be legible and completed in permanent waterproof ink. Corrections must be marked with a single line, dated, and initialed. All documentation, including voided entries, must be maintained within project files.

4.3.1 Project Logbooks

Project logbooks will be kept on-site during field operations. All activities will be recorded in a bound field notebook of water-resistant paper. Entries will be made legibly, in indelible ink, and will be signed and dated. Information recorded will include:

- Date, time and place of sampling;
- Duplicate samples;
- Site-specific QC samples;
- Data from field measurements (sample location, etc.);
- Sample preservation procedures used if any;
- Calibration activities of health and safety monitoring instruments;
- Sampling procedures;
- Observations about site and samples (odors, appearance, etc.);
- Sampling equipment;
- Decontamination procedures; and
- Health and safety issues.

Observations or measurements taken in an area where contamination of the field notebook may occur can be recorded in a separate bound and numbered logbook before

being transferred to the project notebook. The original records will be retained, and the delayed entry will be noted as such.

Field notebooks are intended to provide sufficient data and observations to enable participants to reconstruct events that occur during field activities. The field notebook entries should be factual, detailed and objective.

4.3.2 Corrections to Documentation

Unless restricted by weather conditions, all original data recorded in field notebooks and on sample identification tags, chain-of-custody records, and receipt-for-sample forms will be written in waterproof ink. These accountable, serialized documents are not to be destroyed or thrown away, even if they are illegible or contain inaccuracies that require a replacement document. If an error is made on an accountable document assigned to one person, that individual may make corrections simply by crossing out the error and entering the correct information. The erroneous information should not be obliterated. Any error discovered on an accountable document should be corrected by the person who made the entry. All corrections must be initialed and dated.

5. Testing and Measurement Protocols

During the field demonstration, analysis of samples for perchlorate and anions will be considered critical for the purposes of this QAPP. Samples will be collected as described earlier in section 4 and analyzed in accordance with the procedures referenced and described below. Table A-8 summarizes the methods to be used during this study.

Table A-8. Analytical Parameters for the Proposed Study

Parameter	Matrix	Lab	Method	Method Type
Perchlorate*	Aqueous	ARA & NELAP Certified	EPA 314.0	Ion Chromatograph
Anions	Aqueous	ARA & NELAP Certified	EPA 300.1	Ion Chromatograph
pH	Aqueous	ARA & NELAP Certified	SM 4500	Electrometric
Turbidity	Aqueous	NELAP Certified	SM 2130B	Nephelometric
Color	Aqueous	NELAP Certified	SM 2120B	Visual Comparison
Hardness	Aqueous	NELAP Certified	SM 2340	Titration
Alkalinity	Aqueous	NELAP Certified	SM 2320B	Titration
Conductance	Aqueous	NELAP Certified	SM 2520	Electrometric
Solids (TS/TDS)	Aqueous	NELAP Certified	SM 2540	Gravimetric
Metals (Ca, Cu, Fe, Mg, Mn, K, Na, Zn)	Aqueous	NELAP Certified	EPA SM 3125	ICP/MS
NDMA	Aqueous	NELAP Certified	EPA 521	GC/MS
Heterotrophic Plate Count	Aqueous	NELAP Certified	SM 9215	Membrane filter method
Total Coliform	Aqueous	NELAP Certified	SM 9221	Fermentation, replicate tubes

Notes: * Critical compound for performance validation is perchlorate.

The following paragraphs summarize the laboratory protocols and calibration requirements for the critical measurements.

5.1 Laboratory Protocols

The critical parameter for this study is the analysis of anions – specifically perchlorate– in groundwater. Throughout the demonstration, the concentration of the anions will be monitored to assess the performance of the technology.

5.1.1 Inorganic Anions by Methods 300.1 (anions) and 314.0 (perchlorate)

These methods cover the determination of inorganic anions in surface water, groundwater, and drinking water. A volume of sample ranging from 10-1000ul is introduced into an ion chromatograph. The anions of interest are separated and measured, using a system comprised of a guard column, analytical column, suppressor device, and conductivity detector. The methods differ by the size of the sample loop, the column used, and the mobile phase selected to elute the anion of interest from the analytical column. When various contaminants are present at different orders of magnitude, the laboratory will perform analyses using multiple dilutions of the sample as necessary to quantitate the compound at higher concentrations and still achieve low detection limits for other compounds. Inorganic anions analyzed by EPA 300.1 and 314.0 will be calibrated in accordance with method requirements.

An analysis batch will consist of no more than 20 samples. These included the field samples as well as any QA/QC check samples. Within the analysis batch, for every group of ten field samples, at least one Lab Reagent Blank (LRB) and Continuing Calibration Check Standard (CCAL) must be analyzed. The CCAL should consist of a mid-point standard, prepared fresh from the calibration standard stock. An initial calibration will be performed using 5 standards at concentrations ranging from the reporting detection limit (RDL) to the upper limit of linearity. Routine initial calibration (ICAL) criteria will be met with the additional requirement that the linearity criteria of RSD <20%. The continuing calibration standard (CCAL) analyzed every 10th field sample and must meet routine CCAL requirements.

5.1.2 External NELAP Certified Laboratory Analysis

The additional non-critical analytical procedures listed in Table A-3 are to be performed by a NELAP Certified Laboratory in accordance with approved Standard Methods for the examination of water. The QA/QC standards specified under each method will be followed and documented by the laboratory. A detailed report including QA/QC results will be included with the submission of all analytical results.

6. QA/QC Checks

For this project, QA objectives have been established to ensure that data generated are of adequate quality to achieve technical objectives. The QA objectives for the critical data collected during the demonstration are presented in Table A-9. Acceptance criteria for accuracy, precision, and completeness are listed, along with the expected detection limit of the devices used to take the critical measurements. Overall, QA objectives for non-critical parameters are also noted as guidelines. The discussion below includes a summary of how these objectives will be assessed in the laboratory. Specific QC check procedures for critical measurements are discussed in section 6.2; including corrective actions to be taken in the event these QC checks do not meet criteria.

6.1 QA Objectives

Critical measurements for this project are inorganic anions, primarily perchlorate. Table A-9 summarizes QA objectives for all parameters to be analyzed, with the achievement of these objectives for the critical parameters discussed below.

Precision for anions will be assessed by the analysis of duplicate matrix spikes (MS/MSDs) performed on select project samples to determine the reproducibility of the measurements. The relative percent difference (RPD) between the spiked sample concentrations will be compared to the objectives given in Table A-9. Precision for non-critical parameters will be assessed by the routine QC associated with the analytical batch (duplicate samples analyzed using project or non-project samples run in the same batch as the project samples).

Accuracy objectives for anions are evaluated by the percent recovery of the MS/MSDs performed using project samples. A Laboratory Control Sample (LCS), or spike in a blank, will be analyzed with each MS/MSD to confirm analytical accuracy in the absence of matrix effects. These analyses are discussed further in the following subsection.

Table A-9. QA Objectives for Critical Parameters

Parameter	Matrix	Type (1)	Method	Precision (2)	Accuracy (3)	RDL (4)	Units
Perchlorate	Aqueous	C	EPA 314.0	20	80-120 %	2.5	ug/L
Anions (Nitrate, Sulfate)	Aqueous	NC	EPA 300.1	20	80-120 %	1.5	mg/L

- Notes: (1) Parameter type is C=critical, NC=non-critical.
 (2) Precision is assessed by RPD between the MS/MSD pair or by a sample and duplicate.
 (3) Accuracy objectives are based on the % recovery of spiked samples.
 (4) The RDL (reporting detection limit) is based on the lowest calibration standard.

Detection limits for this project are defined as the reporting detection limit (RDL) as determined by the lowest concentration standard meeting the specified calibration criteria. For the inorganic anion determinations, the detection limit of perchlorate on an undiluted aqueous sample will be set at 4.0 ppb by EPA Method 314.0. Detection limits will be adjusted as necessary based on the matrix and the need for dilution or by the amount of sample concentrated with the on-line method. Method detection limits are derived based on the analysis of 7 replicate low-level standards and the standard deviation (SD) of the results: $MDL = 3SD$.

Comparability is based on the use of established, EPA-approved methods for the analysis of the critical parameter, as well as most non-critical parameters.

Representativeness is achieved by collecting samples representative of the matrix at the time of collection. For the aqueous samples critical to this project, this is achieved by the collection of an aliquot of well-mixed sample.

6.2 QC Checks

General QA objectives have been discussed in the preceding paragraphs. The following QC check procedures will be utilized to assess the precision and accuracy of the measurements associated with the critical parameters. The required QC samples include: Lab Reagent Blank (LRB), Initial Cal Check (ICAL), Lab Control Sample (LCS), Continuing Cal Check (CCAL), and Field Duplicate (Dup). These checks are summarized in Table A-10, and are discussed further below.

Calibration criteria were described earlier in section 5.1. In addition to calibration requirements, inorganic anion analysis will include the analysis of MS/MSD samples that are prepared using project samples, and designated at a frequency of 5 % of the samples. Samples will be spiked by the addition of approximately 5 times the native sample concentration, as estimated based on historical data or after screening the primary sample. The sample, MS and MSD will all be analyzed in the same batch at the same dilution, even if this requires reanalysis of the primary sample. If the initial spike preparation results in spiking levels that are inappropriately low relative to the native sample concentration, the three samples (primary, MS and MSD) will be analyzed with each spiked pair. If the results of both the LCS and the MS/MSD do not meet criteria, analysis will stop until the problem is identified and corrected. If one or the other fails, but not both, the laboratory analyst will contact the QA Coordinator to discuss and determine the appropriate corrective action.

Table A-10: QC Checks for Critical Anion Analysis

QC Check	Frequency	Criteria	Corrective Action
ICAL	Initially and as needed;	RSD <20%; EPA 300.1 criteria (see method)	Reanalyze calibration; prepare new standards as necessary
CCAL	Every 12 hours	RF <20% RPD,	Rerun CCAL standard; recalibrate if needed
Method blank	Every 12 hours	< RDL (for critical cpds)	Rerun; system maintenance
MS/MSD	As per COC or 5%	<u>Aqueous</u> : % recovery 80-120; 20% RPD;	Reanalyze sample and spikes; if still fails, flag data; if LCS also fails - stop analysis and contact QAC
Field duplicates	As per sampling schedule	<u>Aqueous</u> RPD < 20 %;	Flag data

7. Data Reporting, Data Reduction, and Data Validation

For data to be scientifically valid, legally defensible, and comparable, valid equations and procedures must be used. Evaluation of measurements is a systematic process of reviewing a body of data to provide assurance that the quality of the data is adequate for its intended use. The following sections describe the data reporting, data reduction and data validation procedures to be used for laboratory data.

7.1 Laboratory Reporting

Laboratory reports will include tabulated results of all samples. The final report will also include method summaries, detailing any deviations or modifications of the proposed methods. Data will be submitted in a report with sufficient detail such that independent validation of the data can occur. Raw data will include any calibration information, instrument printouts, lab bench sheets, sample preparation information, etc. The completed report will be reviewed by the laboratory QA manager, and approved by the laboratory project manager (or their designees) prior to submission.

7.2 Data Reduction

All data reduction will be completed as specified in the appropriate method. Where data reduction is not computerized, assumptions and calculations will be recorded on the raw data printouts, on pre-printed bench sheets, or in permanently bound notebooks. The data reduction for some analyses includes analysts' interpretations of the raw data and manual calculations. When this is required, the analysts' observations will be written in ink on the raw data sheets. Any corrections to data sheets will be made by lining out inaccurate information, dating and initialing the line-out, and adding the revised information next to the line-out.

7.3 Data Validation

Data generated in each analytical section shall be reviewed by the analytical task leader on a daily basis for completeness. The personnel involved at each stage in data reduction, validation and reporting are shown in Section 2-2. Data will be reported in standard units, as described above. Data validation begins with the analyst and continues until the data are reported. The analysts will verify and sign the appropriate forms to verify the completeness and correctness of data acquisition and reduction. An independent reviewer will review this information to ensure close adherence to the specified analytical method protocols. All instrument systems must be in control and QA objectives for precision, accuracy, completeness, and method detection limits must be met. In the event that data do not meet the project objectives, the sample shall be reanalyzed or re-extracted. If the sample still does not meet project requirements, the QA Coordinator shall be notified immediately. The problem(s) will be discussed and appropriate corrective action shall immediately be implemented. If project objectives have been impacted, or changes were required in analytical procedures, these modifications will be clearly noted in the Final Report.

The principal criteria that will be used to validate the integrity of data during collection and reporting are as follows:

- Verification by the project analyst that all raw data generated for the project have been documented and stored. Storage locations must also be documented in the laboratory records;
- Examination of the data by the laboratory manager or his or her designee to verify adequacy of documentation and agreement with method protocols; and
- Reporting of all associated blank, standard, and QC data, along with results for analysis of each batch of samples.

Analytical outlier data are defined as those QC data lying outside a specific QC objective window for precision or accuracy of a given analytical method. Should QC data be outside of control limits, the laboratory supervisor will investigate the potential causes of the problem. Corrective action (as discussed and tabulated in section 6) will be initiated as necessary, documented, and if unresolved the data will be reported flagged with a data qualifier.

7.4 Data Storage Requirements

The subcontracted analytical laboratories will be responsible for storing on disc all raw data for five years. ARA and/or its subcontractors will retain all hard copies of the analytical data for a period of five years. ARA and/or its subcontractors will also retain the field log books and other correspondence and deliverables for five years.

7.5 Final Technical Reports

The validated field and analytical data will be used to prepare the Technical Evaluation Report, evaluating the field and bench studies and assessing the technologies studied potential for full scale application. The report will contain, at a minimum, the information requirements as specified in the ESTCP guidance document. The report will include a QA review and discussion as a separate and identifiable section. This review will include, at a minimum, the following information:

- A thorough discussion of the procedures used to define data quality and usability and the results of these procedures. The discussion will focus on the data quality indicators such as precision, accuracy, completeness, comparability and representativeness and will include summary tables of the QC data obtained during the demonstration. Results will be compared to the data quality objectives set forth in the QAPP to provide an assessment of the factors that contributed to the overall quality of the data.
- The results of any technical systems and/or performance audits performed during the course of the project will be documented, including corrective actions initiated as a result

of these audits and any possible impact on the associated data. If any internal audits were performed, these too will be reviewed.

- All changes to the original QAPP will be documented regardless of when they were made. The rationale for the changes will be discussed along with any consequences of these changes.
- The identification and resolution of significant QA/QC problems will be discussed. Where it was possible to take corrective action, the action taken and the result of that action will be documented. If it was not possible to take corrective action (for example, a sample bottle was broken in transit), this, too will be documented.
- A discussion of any special studies initiated as a result of QA/QC issues and/or corrective actions, including why the studies were undertaken, how they were performed and how the results impacted the project data.
- A summary of any limitations on the use of the data will be provided including conclusions on how these constraints affect project objectives.

The QA section will provide validation of the measurements used in the demonstration (and subsequent acceptance/rejection) of this technology. This section (and the final report) will be subject to review by the, QA, and project manager. This review will assess the assumptions made in evaluating the data and the conclusions drawn. The project manager must approve the reports prior to release.

8. Assessments

A quality assurance audit is an independent assessment of a measurement system. QA audits may be internal or external audits and performance or system audits. Internal laboratory audits are conducted by the project laboratory's QA/QC coordinator and may be functionally independent of the sampling and analytical teams. External audits are those conducted by an independent organization, such as ESTCP. For this project there will be an internal systems audit conducted by the QA Manager during the field demonstration of the laboratory performing the critical analysis. Performance and system audits are described below.

8.1 Performance Audits

Performance audits are intended to quantify performance of the total measurement system. These types of audits often include performance evaluation samples supplied by an independent regulatory agency. This type of audit is not envisioned for this project.

8.2 Systems Audits

Systems audits will be conducted on sampling/analysis activities by the QA Manager or his designee. These audits are designed to ensure systems are in place for satisfactory sampling and analysis as designated in the QAPP. As appropriate, those audits will consist of any or all of the following items:

- Review the organization and responsibilities to determine the functional operation of the quality assurance program.
- Determine if standard operating procedures are available and implemented as written or as specified in the QAPP.
- Assess traceability of samples and data.
- Determine if appropriate QC checks are being made and that appropriate documentation is maintained.
- Determine if the equipment specified is available, calibrated, and in proper working condition.
- Assure records are properly maintained, including notebooks, log sheets, bench sheets, and tracking forms.
- Verify use of appropriate chain of command methods in responding to variances and implementing corrective action.
- Prepare a project and QA report as designated in the laboratory scope of work to be submitted to the Project Manager and the QA Manager.

8.3 Corrective Action

Corrective actions will be taken upon identification of any problems with the project that affect product quality. The initial line of responsibility for identifying the causes of laboratory problems lies with the analyst, who along with the Laboratory QA Manager or Laboratory Technical Manager will work towards developing a solution. Field personnel who identify a

problem with data collection activities will report the difficulty to the project manager or QA Coordinator. The root cause(s) of the problem will be determined, and its effect on the program will be identified. The QA/QC Coordinator and appropriate manager (e.g., laboratory coordinator) and, if necessary, the project manager, will develop a corrective action.

As data problems arise, the contractor team will investigate the problems and perform one or more of the following actions:

- If the problem occurs in the field, the field manager will try to correct the problem. If the field manager cannot correct the problem without loss of field data or samples, he/she will immediately contact the Project Manager or QA Coordinator for additional instructions.
- If the problem occurs in the laboratory, the laboratory supervisor will try to correct the problem. If the laboratory supervisor cannot correct the problem without loss of analytical data of known quality, he or she will immediately contact the laboratory project manager and/or their respective QA coordinator for additional instructions.

8.3.1 Corrective Action for Performance/Systems Audits

As noted above, field and laboratory activities will be audited to ensure that required field and laboratory procedures are being followed. If deficiencies or problems are discovered during the audit, the appropriate QA/QC coordinator or their designees will prepare a corrective action memorandum to document the procedures to be implemented to correct the deficiency.

8.3.2 Corrective Action for Data Outside Control Limits

If at any time the data fall outside previously designated limits, the following actions will be taken:

- If instruments are not within calibration limits, the instruments will be recalibrated; samples will be reanalyzed once an acceptable calibration has been obtained.
- If a field/laboratory person or engineering staff member observes data problems (for example, if results for specific QC analysis are outside the QC limits), he or she will immediately notify the appropriate QA/QC coordinator or project director. A determination will be made on the impact of the problem on the data quality and whether any corrective action should be taken.
- If a field/laboratory person observes procedures not being done in accordance with the QA Project Plan he or she will immediately notify the appropriate QA/QC coordinator or project director.

Appendix C

Summary of Data Results for each Test Period

during the

ESTCP Field Demonstration

at

Wellsite F17C - Fontana, California

February 26, 2007

**ESTCP PROJECT NUMBER ER-0312
ARA PROJECT NUMBER 16623-0003**

1. Introduction

This appendix is provided to summarize conditions during each test period and the operational data collected; identify sampling locations and summarize analytical data provided by certified laboratories; and summarize analytical data conducted by ARA and the quality assurance and quality control data collected.

2. Test Matrix Summary

Six test periods were conducted during this demonstration. Four test periods were breakthrough tests (1, 2, 5, and 6). During these tests, test periods were defined as the period from initiation of flow through a new column in the lead position, until the column was removed from service for regeneration. During regeneration of the spent column, the lag column remained online and treated water in a single column. The remaining two test periods (3 and 4) were short-cycle tests. Short-cycle tests were defined as a column that is regenerated, after approximately one week on-line and before breakthrough was observed. These short-cycle tests were conducted to maximize the number of regenerations per column and minimize the duration of the demonstration. The short-cycle tests were also used to evaluate perchlorate removal efficiency at higher specific flow rates (4 gpm/ft³).

The conditions for each test period are identified in Table B-1. Conditions identified include duration, flow rate, and pretreatment and post treatment settings. Within a test period, these settings may have been adjusted and are reflected in the test matrix. In most cases, adjustments were made to the post treatment settings; however, a flow adjustment was made during test period 3 (3A and 3B) to evaluate treatment performance at a higher flow rate.

Table B-1. Test Matrix Summary

Test Period	1	2A	2B	3A	3B	3C	4	5A	5B	6
Start date	5/18/2006	6/13/2006	6/15/2006	7/12/2006	7/13/2006	7/17/2006	7/19/2006	7/25/2006	7/27/2006	8/15/2006
End date	6/13/2006	6/15/2006	7/11/2006	7/13/2006	7/17/2006	7/19/2006	7/25/2006	7/27/2006	8/15/2006	9/1/2006
Duration (days)	26	2	26	1	4	2	6	2	19	17
System pressure (psi)	15.0	15.0	15.0	15.0	15.0	15.0	15.0	15.0	15.0	15.0
Flow rate										
BV/hr	24	24	24	24	32	24	24	24	24	24
gpm/ft ³	3	3	3	3	4	3	3	3	3	3
Pretreatment										
Acid	H ₂ SO ₄	H ₂ SO ₄	H ₂ SO ₄	H ₂ SO ₄	H ₂ SO ₄	H ₂ SO ₄	H ₂ SO ₄	H ₂ SO ₄	H ₂ SO ₄	H ₂ SO ₄
Concentration (% v/v)	5	5	5	5	5	5	5	5	5	6
pH Setpoint	4.0	4.0	4.0	3.8	3.5	3.7	3.7	3.9	3.9	3.9
Post treatment										
Base	NaOH	NaOH	NaOH	NaOH	NaOH	NaOH	NaOH	NaOH	NaOH	NaOH
Concentration (% v/v)	5	5	5	5	5	5	5	5	5	5
pH Setpoint	6.8	6.8	6.8	6.8	6.8	6.8	6.8	6.8	6.8	6.8
Air strip (percent flow)	100	80	90	90	90	0	0	0	0	0
Calcite contactor (percent flow)	0	20	10	10	10	100	100	100	100	100
Membrane strip (percent flow)	0	0	0	0	0	100	100	100	100	100
Membrane strip (condition)	0	0	0	0	0	Air Sweep	Air Sweep	Air Sweep	10" Hg	10" Hg

3. Operational Data

A data acquisition system was used to collect operational data every ten minutes. Operational data collected include pH of the pretreated groundwater, column effluent, and treated water (post treated water) as well as system flow rate and pressure. The following charts summarize system pH and system flow rate and pressure data collected during each test period. The data is summarized as a 24-hour trendline of the data collected every ten minutes.

3.1. System pH

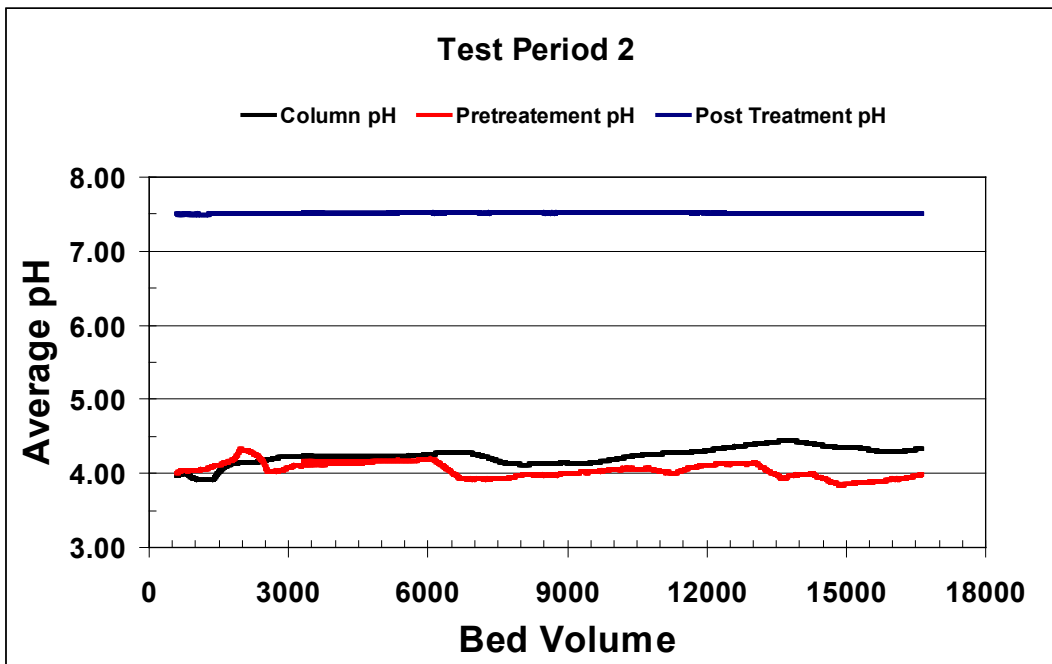
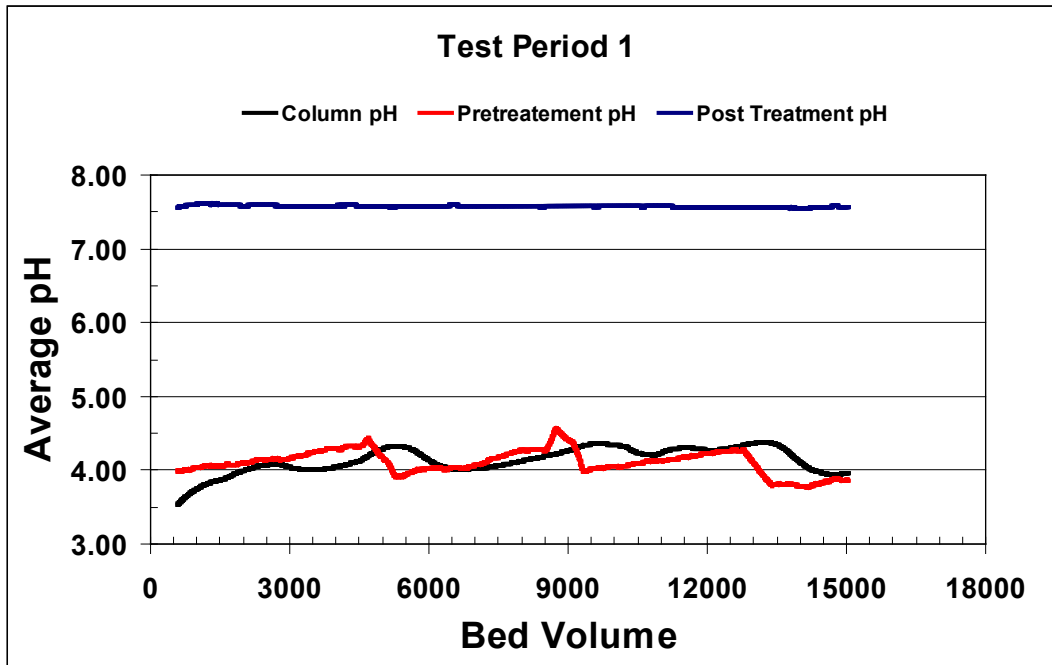

Figure B-1. System pH during Test Periods 1 & 2

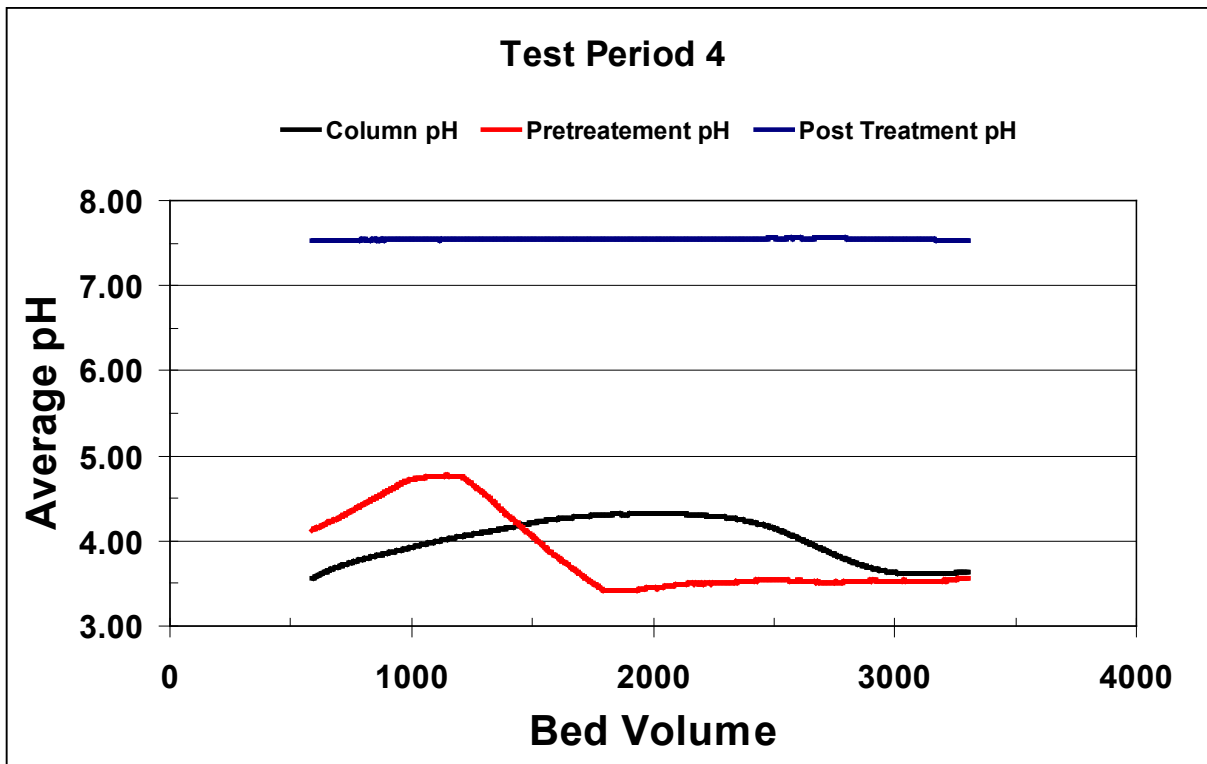
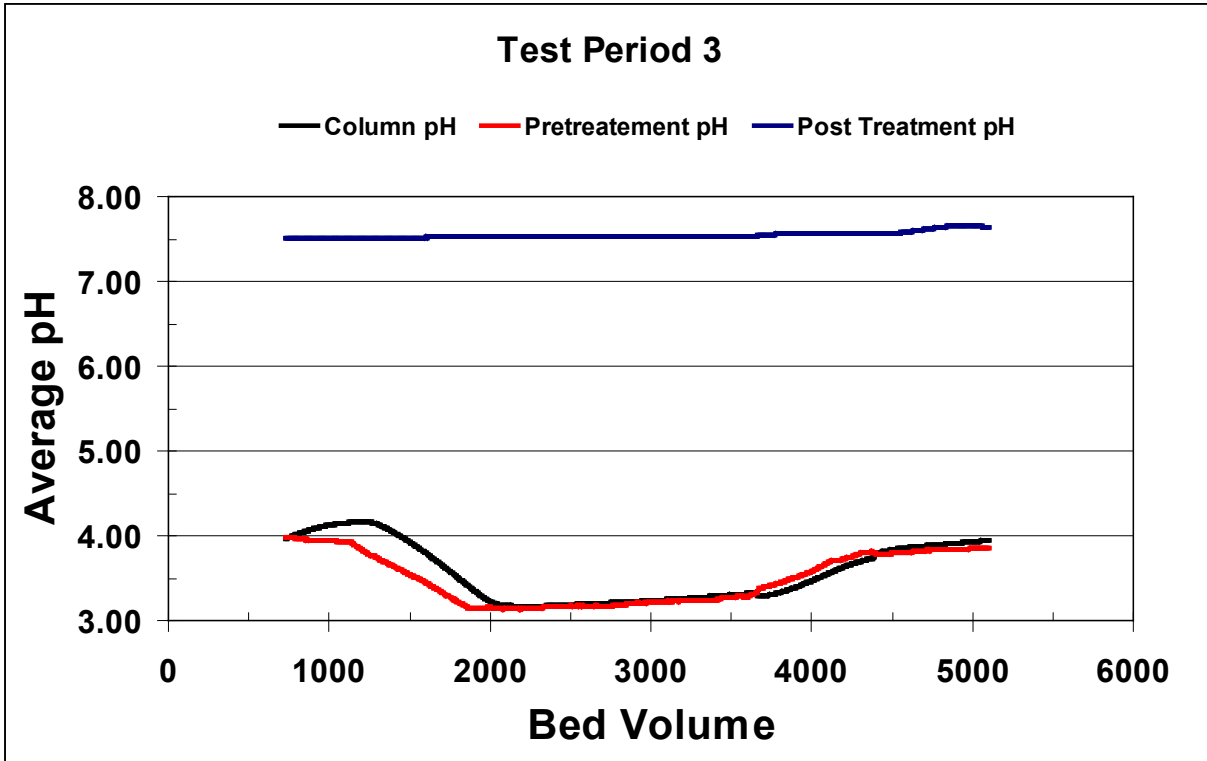

Figure B-2. System pH during Test Periods 3 & 4

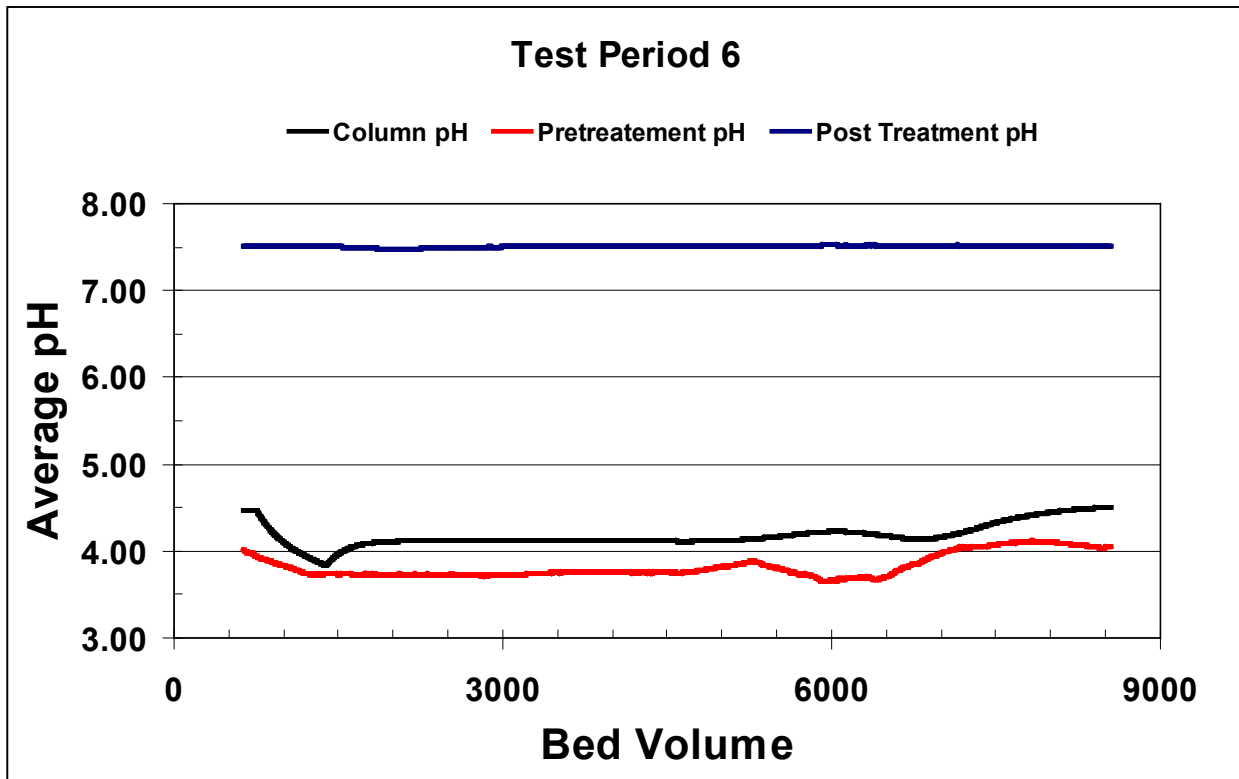
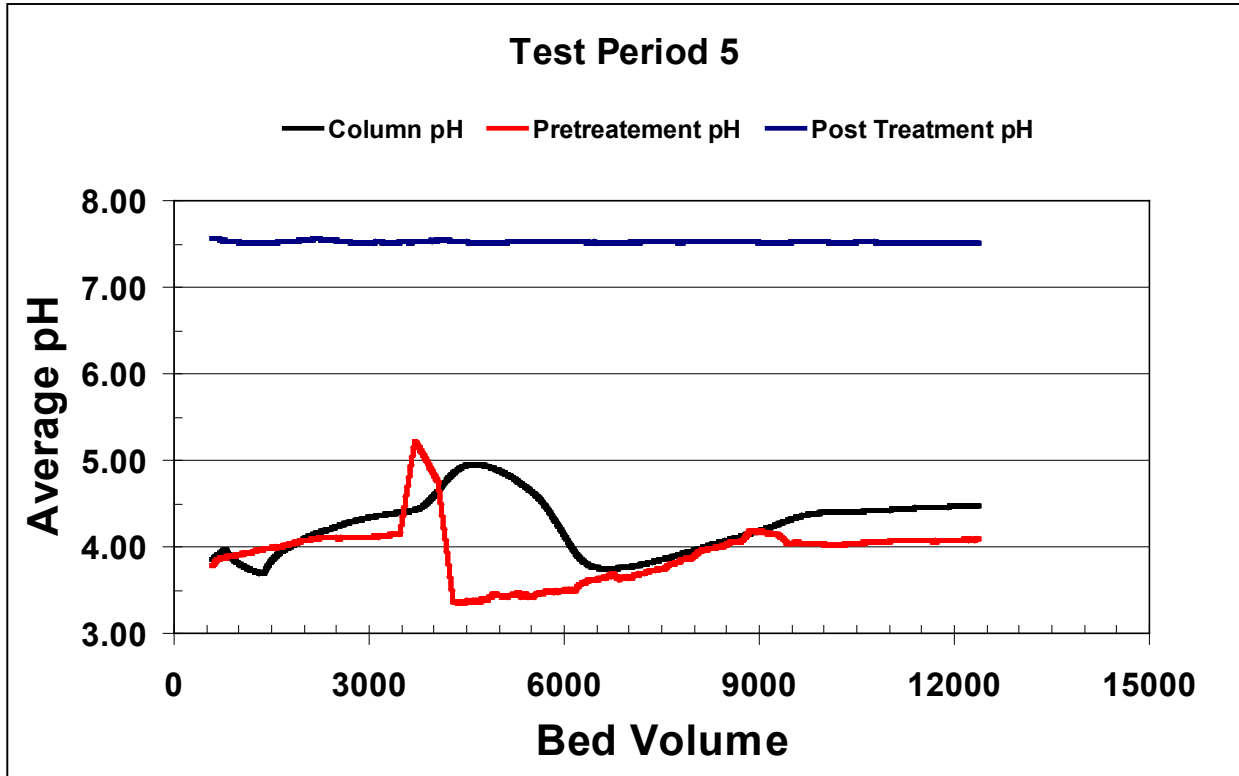

Figure B-3. System pH during Test Periods 5 & 6

3.2. System Flow Rate and Pressure

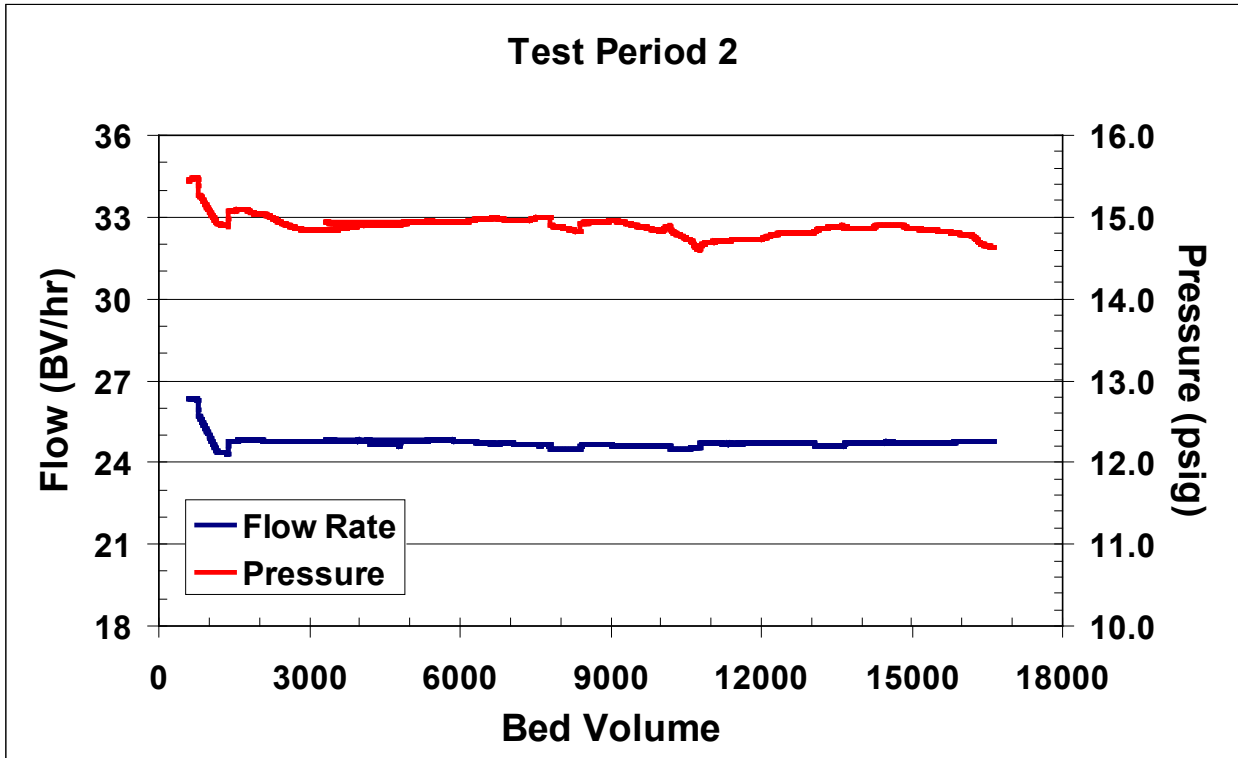
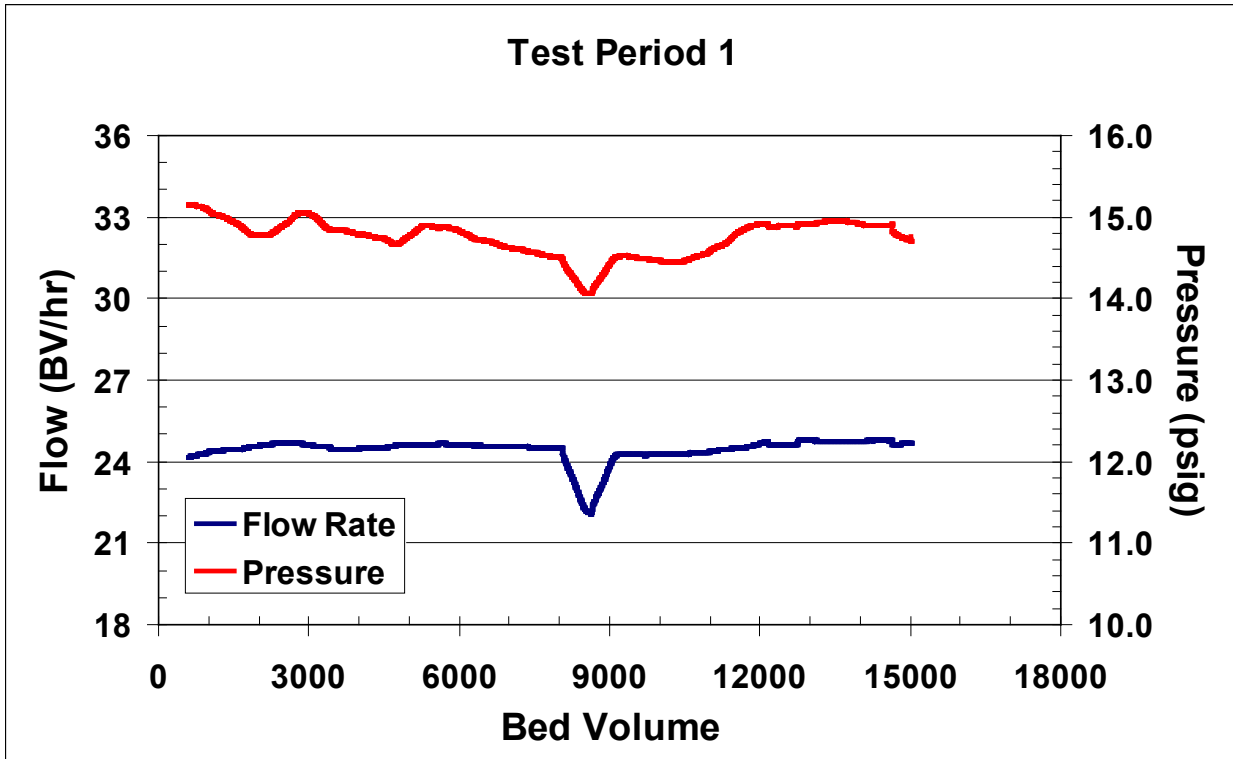

Figure B-4. System Flow and Pressure during Test Periods 1 & 2

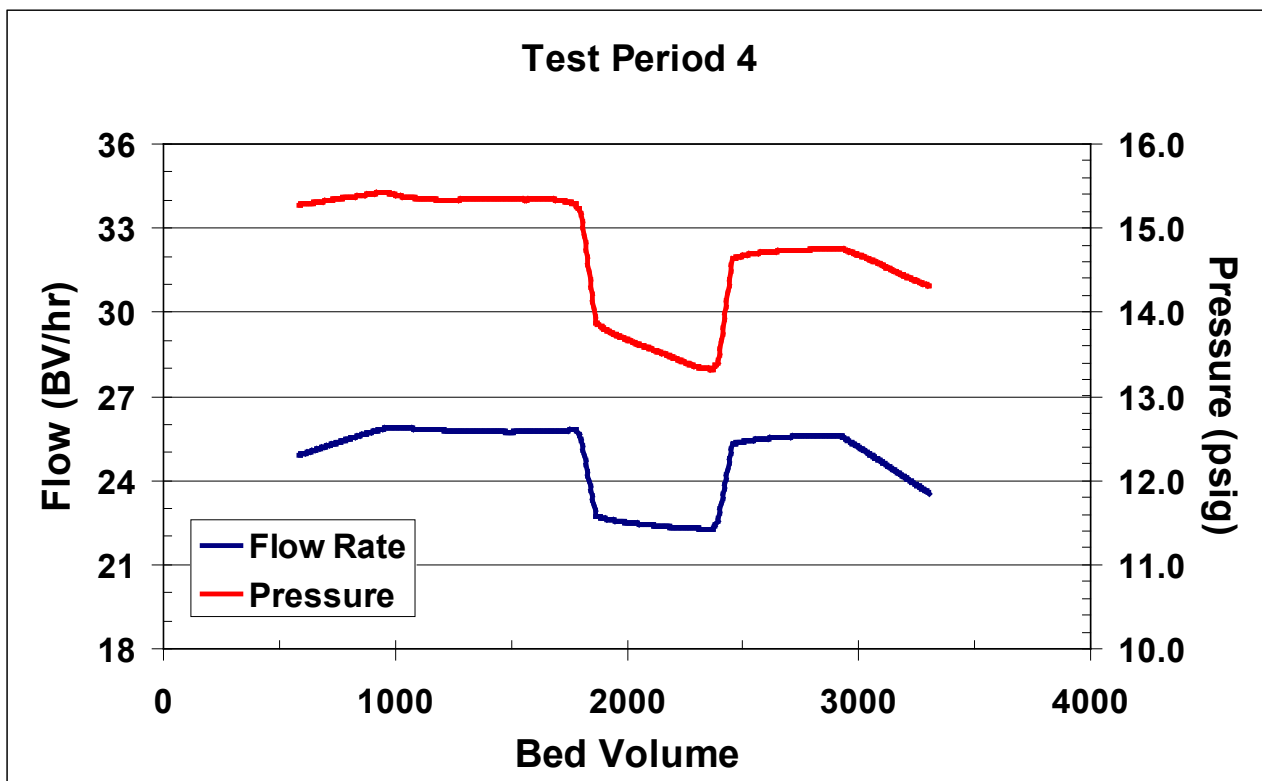
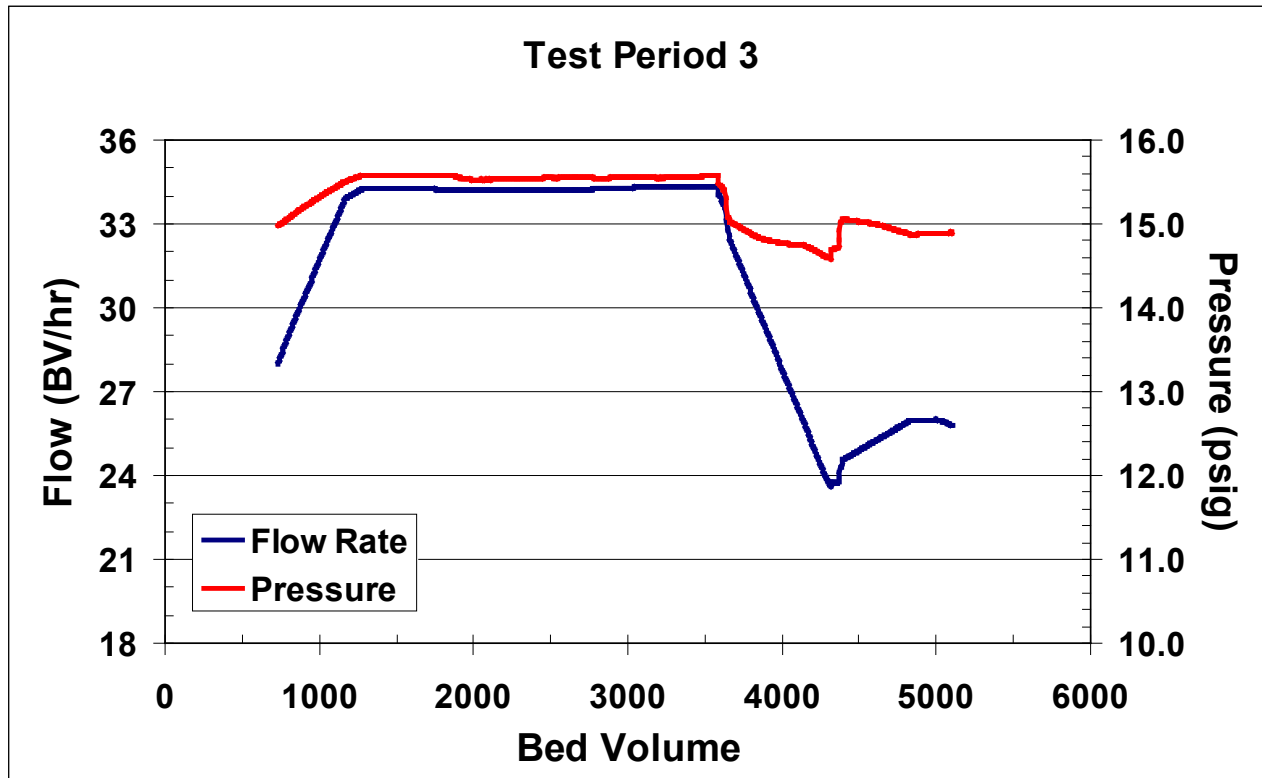

Figure B-5. System Flow and Pressure during Test Periods 3 & 4

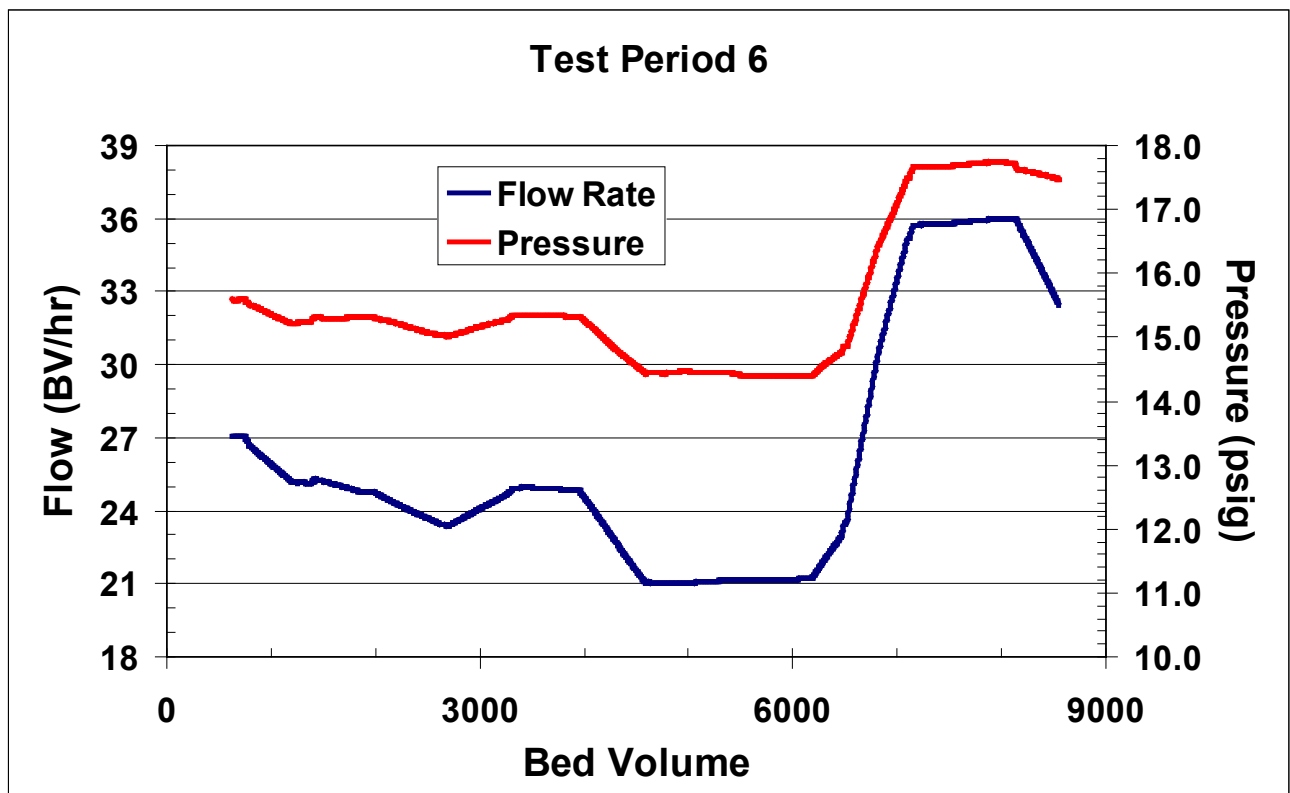
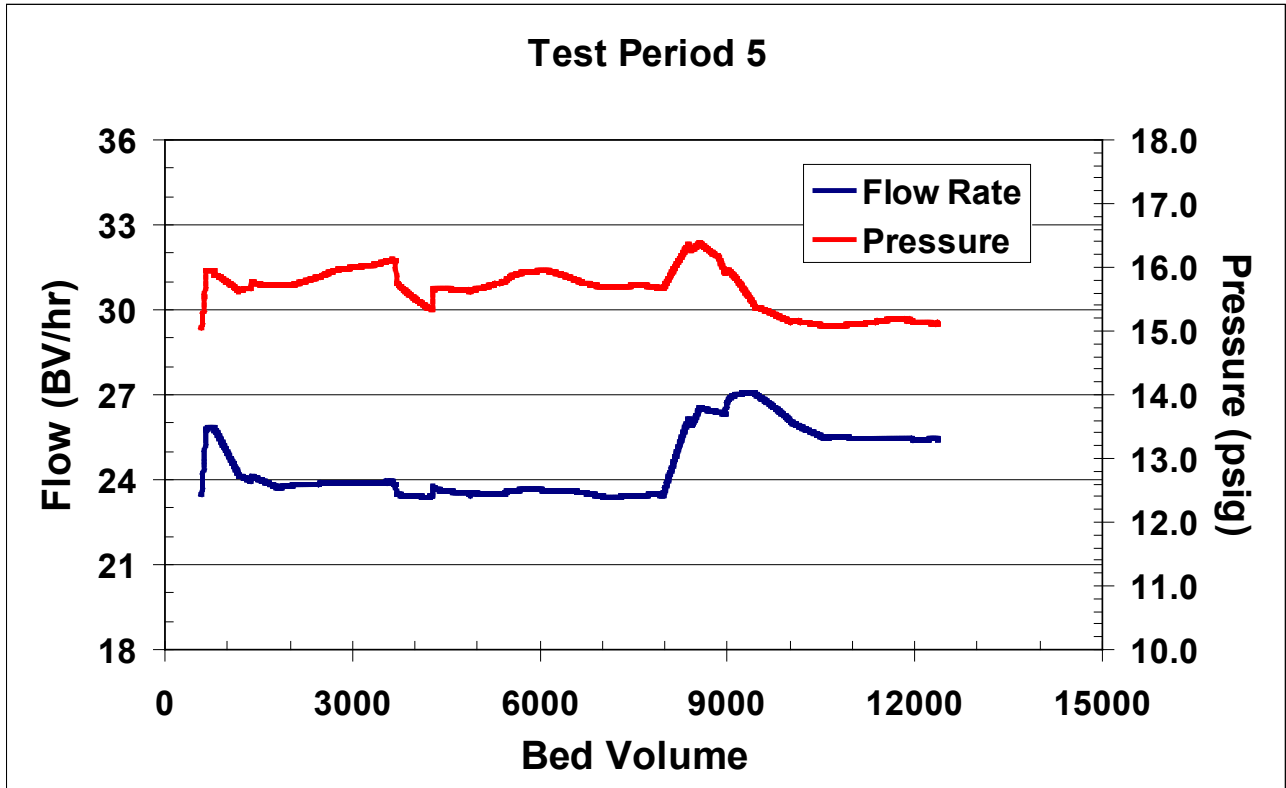

Figure B-6. System Flow and Pressure during Test Periods 5 & 6

4. Analytical Data

During the demonstration, the system was sampled at locations identified in Figure B-7 and analyzed for various parameters by ARA and certified laboratories. This section summarizes results obtained from these laboratories during each test period for perchlorate and other anions, general mineral and physical data, as well as nitrosamines.

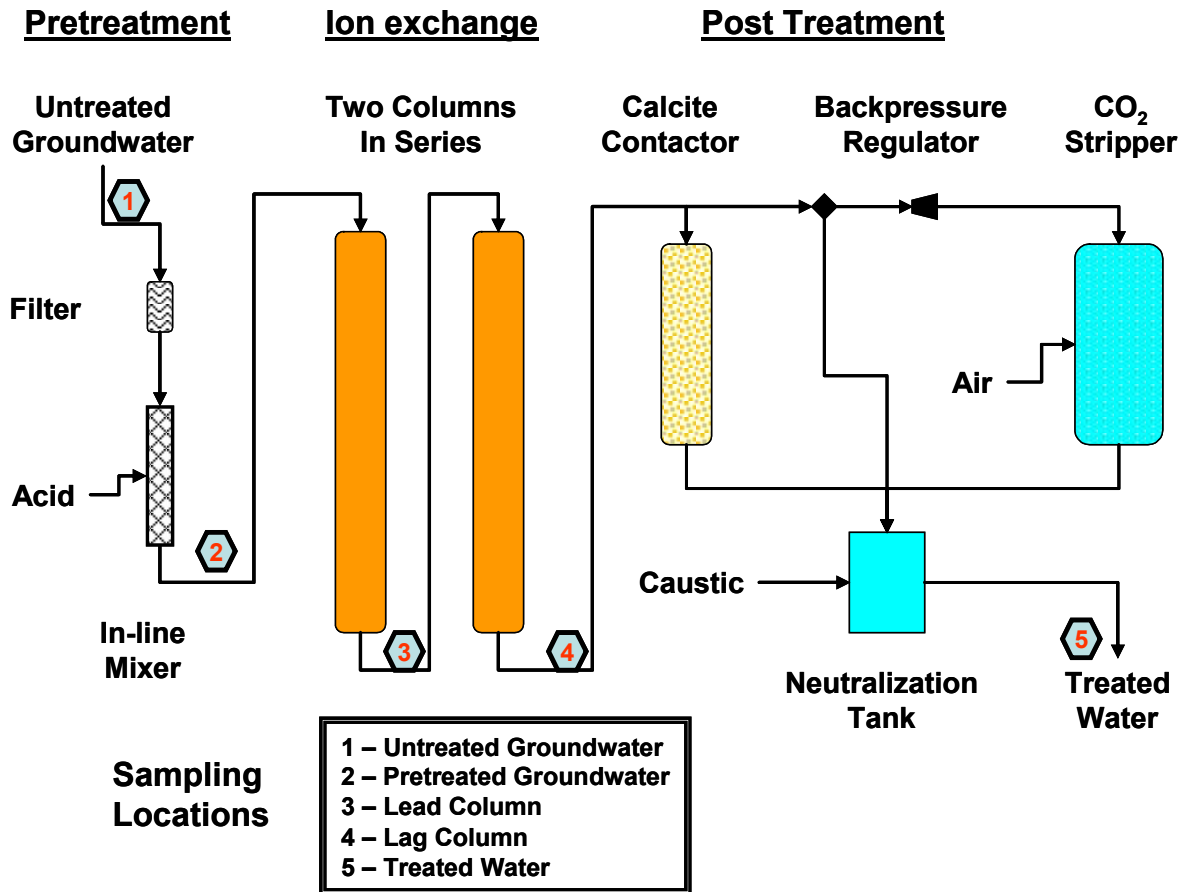

Figure B-7. Sampling Locations

4.1. Analyses provided by ARA

TEST PERIOD 1:

Perchlorate (ug/L) (EPA 314.0)

Date	Total BV Treated	Untreated GW (1)	Pretreated GW (2)	Lead (3)	Lag (4)	Treated (5)
5/18/06	0	6	7	< 2	< 2	< 2
5/19/2006	692	8	13	< 2	< 2	< 2
5/22/2006	2364	8	12	< 2	< 2	< 2
5/24/2006	3580	8	13	< 2	< 2	< 2
5/26/2006	4866	10	15	< 2	< 2	< 2
5/29/2006	6515	9	12	< 2	< 2	< 2
5/31/2006	7672	8	13	< 2	< 2	< 2
6/2/2006	8893	8	11	< 2	< 2	< 2
6/5/2006	10576	11	12	4	< 2	< 2
6/7/2006	11719	7	13	5	< 2	< 2
6/9/2006	12950	5	14	9	< 2	< 2
6/12/2006	14830	9	12	9	< 2	< 2
6/13/2006	15238	7	12	6	< 2	< 2

Nitrate (mg/L) (EPA 300.1)

Date	Total BV Treated	Untreated GW (1)	Pretreated GW (2)	Lead (3)	Lag (4)	Treated (5)
5/18/06	0	27	28	< 1.5	< 1.5	20
5/19/2006	692	28	28	20	< 1.5	< 1.5
5/22/2006	2364	28	29	28	26	25
5/24/2006	3580	29	29	35	33	30
5/26/2006	4866	29	30	31	29	28
5/29/2006	6515	29	29	31	29	28
5/31/2006	7672	29	30	31	29	28
6/2/2006	8893	30	30	39	34	31
6/5/2006	10576	30	30	31	27	26
6/7/2006	11719	30	30	31	29	28
6/9/2006	12950	30	30	32	31	29
6/12/2006	14830	30	30	36	35	31
6/13/2006	15238	31	30	28	27	28

TEST PERIOD 1:**Chloride (mg/L) (EPA 300.1)**

Date	Total BV Treated	Untreated GW (1)	Pretreated GW (2)	Lead (3)	Lag (4)	Treated (5)
5/18/06	0	11	11	4	5	10
5/19/2006	692	11	11	11	12	11
5/22/2006	2364	11	11	11	11	11
5/24/2006	3580	11	11	11	12	11
5/26/2006	4866	11	11	11	11	11
5/29/2006	6515	11	11	11	12	11
5/31/2006	7672	11	11	12	12	11
6/2/2006	8893	11	11	11	12	12
6/5/2006	10576	11	11	11	12	11
6/7/2006	11719	11	11	11	11	11
6/9/2006	12950	11	11	11	12	11
6/12/2006	14830	11	11	11	12	12
6/13/2006	15238	11	11	11	11	11

Sulfate (mg/L) (EPA 300.1)

Date	Total BV Treated	Untreated GW (1)	Pretreated GW (2)	Lead (3)	Lag (4)	Treated (5)
5/18/06	0	14	155	220	257	161
5/19/2006	692	14	155	165	178	179
5/22/2006	2364	14	152	154	154	155
5/24/2006	3580	14	152	149	149	152
5/26/2006	4866	14	150	150	152	152
5/29/2006	6515	14	155	152	153	154
5/31/2006	7672	14	150	151	153	154
6/2/2006	8893	14	143	144	150	151
6/5/2006	10576	14	150	151	154	154
6/7/2006	11719	14	151	151	151	153
6/9/2006	12950	14	152	149	152	152
6/12/2006	14830	14	155	152	156	155
6/13/2006	15238	14	155	154	158	156

TEST PERIOD 2:

Perchlorate (ug/L) (EPA 314.0)

Date	Total BV Treated	Untreated GW (1)	Pretreated GW (2)	Lead (3)	Lag (4)	Treated (5)
6/14/2006	605	6	12	< 2	--	< 2
6/15/2006	1193	7	10	< 2	< 2	< 2
6/16/2006	1983	8	11	< 2	< 2	< 2
6/19/2006	3720	8	13	2	< 2	< 2
6/21/2006	4875	8	13	4	< 2	< 2
6/23/2006	6132	5	9	4	< 2	< 2
6/26/2006	7843	5	8	5	< 2	< 2
6/28/2006	9161	6	7	--	< 2	--
6/30/2006	10058	6	9	6	< 2	< 2
7/3/2006	11963	6	8	8	< 2	< 2
7/5/2006	13056	6	9	6	< 2	< 2
7/7/2006	14273	7	9	7	< 2	2
7/10/2006	16115	6	10	11	2	2
7/11/2006	16665	7	9	9	3	2

Nitrate (mg/L) (EPA 300.1)

Date	Total BV Treated	Untreated GW (1)	Pretreated GW (2)	Lead (3)	Lag (4)	Treated (5)
6/14/2006	605	31	31	29	--	29
6/15/2006	1193	30	31	29	12	6
6/16/2006	1983	31	31	38	37	34
6/19/2006	3720	31	31	37	34	30
6/21/2006	4875	31	31	36	32	29
6/23/2006	6132	31	31	38	36	33
6/26/2006	7843	31	31	33	30	29
6/28/2006	9161	31	31	--	38	--
6/30/2006	10058	31	32	28	26	29
7/3/2006	11963	31	32	35	32	29
7/5/2006	13056	31	32	29	26	29
7/7/2006	14273	32	32	29	26	28
7/10/2006	16115	31	32	34	30	28
7/11/2006	16665	32	32	32	29	29

TEST PERIOD 2:**Chloride (mg/L) (EPA 300.1)**

Date	Total BV Treated	Untreated GW (1)	Pretreated GW (2)	Lead (3)	Lag (4)	Treated (5)
6/14/2006	605	11	11	11	--	11
6/15/2006	1193	11	11	11	11	11
6/16/2006	1983	11	11	11	11	12
6/19/2006	3720	11	11	11	12	12
6/21/2006	4875	11	11	12	12	11
6/23/2006	6132	11	11	11	12	12
6/26/2006	7843	11	11	11	12	11
6/28/2006	9161	11	11	--	11	--
6/30/2006	10058	11	11	11	11	11
7/3/2006	11963	11	11	12	12	12
7/5/2006	13056	11	11	11	11	11
7/7/2006	14273	11	11	11	11	11
7/10/2006	16115	11	11	12	12	11
7/11/2006	16665	11	11	11	12	11

Sulfate (mg/L) (EPA 300.1)

Date	Total BV Treated	Untreated GW (1)	Pretreated GW (2)	Lead (3)	Lag (4)	Treated (5)
6/14/2006	605	14	152	152	--	155
6/15/2006	1193	14	152	153	164	170
6/16/2006	1983	14	140	147	149	150
6/19/2006	3720	14	153	148	149	152
6/21/2006	4875	14	151	148	150	152
6/23/2006	6132	14	156	148	149	151
6/26/2006	7843	14	151	152	154	154
6/28/2006	9161	14	152	--	150	--
6/30/2006	10058	14	152	154	156	155
7/3/2006	11963	14	151	150	152	154
7/5/2006	13056	14	151	153	155	154
7/7/2006	14273	14	151	154	155	154
7/10/2006	16115	15	153	151	153	156
7/11/2006	16665	14	151	152	154	154

TEST PERIOD 3:**Perchlorate (ug/L) (EPA 314.0)**

Date	Total BV Treated	Untreated GW (1)	Pretreated GW (2)	Lag (4)	Treated (5)
7/13/2006	338	5	10	< 2	< 2
7/14/2006	1122	6	12	< 2	< 2
7/17/2006	3691	8	11	< 2	< 2
7/18/2006	4273	8	9	< 2	< 2
7/19/2006	4910	9	12	< 2	< 2

Nitrate (mg/L) (EPA 300.1)

Date	Total BV Treated	Untreated GW (1)	Pretreated GW (2)	Lag (4)	Treated (5)
7/13/2006	338	32	32	12	5
7/14/2006	1122	32	33	30	29
7/17/2006	3691	33	33	33	31
7/18/2006	4273	33	33	31	32
7/19/2006	4910	33	33	31	31

Chloride (mg/L) (EPA 300.1)

Date	Total BV Treated	Untreated GW (1)	Pretreated GW (2)	Lag (4)	Treated (5)
7/13/2006	338	11	11	12	12
7/14/2006	1122	11	11	11	11
7/17/2006	3691	11	12	12	12
7/18/2006	4273	11	11	12	11
7/19/2006	4910	11	11	12	11

Sulfate (mg/L) (EPA 300.1)

Date	Total BV Treated	Untreated GW (1)	Pretreated GW (2)	Lag (4)	Treated (5)
7/13/2006	338	15	150	165	171
7/14/2006	1122	15	187	158	155
7/17/2006	3691	14	173	172	167
7/18/2006	4273	15	152	155	156
7/19/2006	4910	15	152	153	159

TEST PERIOD 4:**Perchlorate (ug/L) (EPA 314.0)**

Date	Total BV Treated	Untreated GW (1)	Pretreated GW (2)	Lead (3)	Lag (4)	Treated (5)
7/20/2006	564	7	10	< 2	< 2	< 2
7/21/2006	1443	7	14	< 2	< 2	< 2
7/23/2006	3072	8	14	2	< 2	< 2
7/25/2006	3519	9	14	2	< 2	< 2
7/26/2006	4093	10	10	< 2	--	< 2

Nitrate (mg/L) (EPA 300.1)

Date	Total BV Treated	Untreated GW (1)	Pretreated GW (2)	Lead (3)	Lag (4)	Treated (5)
7/20/2006	564	32	32	30	8	5
7/21/2006	1443	33	33	39	45	43
7/23/2006	3072	33	32	37	33	30
7/25/2006	3519	33	32	29	29	30
7/26/2006	4093	32	33	30	--	30

Chloride (mg/L) (EPA 300.1)

Date	Total BV Treated	Untreated GW (1)	Pretreated GW (2)	Lead (3)	Lag (4)	Treated (5)
7/20/2006	564	11	11	11	12	12
7/21/2006	1443	11	11	11	11	12
7/23/2006	3072	11	11	12	13	12
7/25/2006	3519	11	11	11	11	11
7/26/2006	4093	12	12	11	--	12

Sulfate (mg/L) (EPA 300.1)

Date	Total BV Treated	Untreated GW (1)	Pretreated GW (2)	Lead (3)	Lag (4)	Treated (5)
7/20/2006	564	14	152	154	171	177
7/21/2006	1443	14	157	143	145	146
7/23/2006	3072	15	159	167	168	161
7/25/2006	3519	16	156	163	165	161
7/26/2006	4093	15	150	153	--	155

TEST PERIOD 5:

Perchlorate (ug/L) (EPA 314.0)

Date	Total BV Treated	Untreated GW (1)	Pretreated GW (2)	Lead (3)	Lag (4)	Treated (5)
7/27/2006	392	6	10	< 2	< 2	< 2
7/28/2006	1110	9	11	< 2	< 2	< 2
7/31/2006	2851	9	14	< 2	< 2	< 2
8/1/2006	3393	--	--	< 2	< 2	--
8/2/2006	4035	8	14	< 2	< 2	< 2
8/4/2006	5167	8	13	< 2	< 2	< 2
8/7/2006	6810	8	12	2	< 2	< 2
8/9/2006	7893	8	6	< 2	< 2	< 2
8/11/2006	8537	6	14	3	< 2	< 2
8/14/2006	9135	6	7	6	< 2	< 2
8/15/2006	11173	6	8	3	< 2	< 2

Nitrate (mg/L) (EPA 300.1)

Date	Total BV Treated	Untreated GW (1)	Pretreated GW (2)	Lead (3)	Lag (4)	Treated (5)
7/27/2006	392	32	32	30	15	7
7/28/2006	1110	33	33	36	34	32
7/31/2006	2851	32	33	69	36	32
8/1/2006	3393	--	--	28	30	--
8/2/2006	4035	32	32	33	28	26
8/4/2006	5167	32	32	38	36	33
8/7/2006	6810	32	32	39	36	33
8/9/2006	7893	32	32	33	31	31
8/11/2006	8537	33	33	31	29	31
8/14/2006	9135	33	33	39	37	33
8/15/2006	11173	32	32	30	29	31

Chloride (mg/L) (EPA 300.1)

Date	Total BV Treated	Untreated GW (1)	Pretreated GW (2)	Lead (3)	Lag (4)	Treated (5)
7/27/2006	392	11	11	11	12	12
7/28/2006	1110	12	11	11	12	12
7/31/2006	2851	12	12	13	14	13
8/1/2006	3393	--	--	11	12	--
8/2/2006	4035	11	11	11	12	12
8/4/2006	5167	11	11	11	12	12
8/7/2006	6810	12	12	12	12	12
8/9/2006	7893	12	12	12	12	12
8/11/2006	8537	12	12	12	12	11
8/14/2006	9135	11	12	12	12	12
8/15/2006	11173	11	11	11	11	11

TEST PERIOD 5:**Sulfate (mg/L) (EPA 300.1)**

Date	Total BV Treated	Untreated GW (1)	Pretreated GW (2)	Lead (3)	Lag (4)	Treated (5)
7/27/2006	392	14	150	153	166	175
7/28/2006	1110	15	152	150	153	154
7/31/2006	2851	15	176	105	145	150
8/1/2006	3393	--	--	146	146	--
8/2/2006	4035	15	171	160	151	152
8/4/2006	5167	15	160	159	160	156
8/7/2006	6810	15	153	149	150	153
8/9/2006	7893	15	137	148	152	152
8/11/2006	8537	15	150	150	152	151
8/14/2006	9135	15	149	146	147	150
8/15/2006	11173	14	146	148	150	149

TEST PERIOD 6:**Perchlorate (ug/L) (EPA 314.0)**

Date	Total BV Treated	Untreated GW (1)	Pretreated GW (2)	Lead (3)	Lag (4)	Treated (5)
8/16/2006	627	5	16	< 2	--	< 2
8/16/2006	627	--	--	< 2	< 2	--
8/17/2006	1170	4	7	< 2	< 2	< 2
8/18/2006	1772	7	10	< 2	< 2	< 2
8/21/2006	3726	7	9	< 2	< 2	< 2
8/23/2006	4767	6	10	< 2	< 2	< 2
8/25/2006	5611	4	5	< 2	< 2	< 2
8/28/2006	8047	6	7	< 2	< 2	< 2
8/30/2006	9818	5	7	3	< 2	< 2
9/1/2006	10847	6	6	4	< 2	< 2

Nitrate (mg/L) (EPA 300.1)

Date	Total BV Treated	Untreated GW (1)	Pretreated GW (2)	Lead (3)	Lag (4)	Treated (5)
8/16/2006	627	32	33	31	--	30
8/16/2006	627	--	--	38	0	--
8/17/2006	1170	32	33	30	18	10
8/18/2006	1772	33	33	31	30	30
8/21/2006	3726	33	33	39	37	34
8/23/2006	4767	33	33	38	37	35
8/25/2006	5611	32	33	31	29	30
8/28/2006	8047	29	30	29	27	28
8/30/2006	9818	29	29	33	34	32
9/1/2006	10847	29	30	33	31	29

TEST PERIOD 6:**Chloride (mg/L) (EPA 300.1)**

Date	Total BV Treated	Untreated GW (1)	Pretreated GW (2)	Lead (3)	Lag (4)	Treated (5)
8/16/2006	627	11	11	12	--	11
8/16/2006	627	--	--	12	2	--
8/17/2006	1170	12	11	11	12	12
8/18/2006	1772	12	11	12	12	12
8/21/2006	3726	12	12	11	12	12
8/23/2006	4767	12	12	11	12	12
8/25/2006	5611	12	11	12	12	12
8/28/2006	8047	11	11	11	11	11
8/30/2006	9818	11	11	11	11	11
9/1/2006	10847	11	11	11	12	11

Sulfate (mg/L) (EPA 300.1)

Date	Total BV Treated	Untreated GW (1)	Pretreated GW (2)	Lead (3)	Lag (4)	Treated (5)
8/16/2006	627	15	149	149	--	150
8/16/2006	627	--	--	147	226	--
8/17/2006	1170	14	152	152	161	169
8/18/2006	1772	15	153	153	154	155
8/21/2006	3726	15	153	150	149	153
8/23/2006	4767	15	151	151	152	153
8/25/2006	5611	15	151	154	154	155
8/28/2006	8047	14	147	149	150	151
8/30/2006	9818	14	146	148	148	148
9/1/2006	10847	15	149	149	--	150

4.2. Analyses provided by Certified Laboratory: Babcock Laboratories

Perchlorate (ppb) (IC/MS/MS)				
Date	Test Period	Bed Volumes	Lead (3)	Lag (4)
6/7/06	1	11719	4.1	<0.10
6/12/06	1	14830	6.5	0.19
6/15/06	2	1193	<1.0	<1.0
6/26/06	2	7843	4.5	<1.0
7/13/06	3	338	0.46	--
7/14/06	3	1122	0.33	--
7/17/06	3	3691	0.26	--
7/19/06	3	4910	0.11	--
8/16/06	6	24	0.49	0.29
9/1/06	6	9200	--	0.53

4.3. Analyses provided by Certified Laboratory - Associated Laboratories

Parameter	Units	Test Period 1							
		Pretreated (2)	Lag (4)	Treated (5)	Untreated (1)	Pretreated (2)	Lag (4)	Lead (3)	Treated (5)
Sample Location									
Bed Volumes		692	692	692	14830	14830	14830	14830	14830
Date		5/19/06	5/19/06	5/19/06	6/12/06	6/12/06	6/12/06	6/12/06	6/12/06
pH		4.98	--	7.02	7.89	4.16	--	--	3.96
Perchlorate	ug/L	7.5	--	<4	--	8.0	--	--	--
Nitrate (as NO ₃)	mg/L	<0.44	--	29.4	30.6	29.9	--	--	33.1
Sulfate	mg/L	193	--	164	13.8	161	--	--	160
Chloride	mg/L	10.6	--	10.1	9.5	9.5	--	--	9.8
Fluoride	mg/L	0.14	--	0.14	0.2	0.17	--	--	0.17
Anions	mEq/L	4.46	--	4.35	4.1	4.10	--	--	4.14
Cations	mEq/L	4.73	--	4.35	4.01	4.15	--	--	4.07
TDS	mg/L	300	--	320	240	320	--	--	320
Bicarbonate	mg/L	9.2	--	11	186	<5.0	--	--	<5.0
Carbonate	mg/L	<5.0	--	<5.0	<5.0	<5.0	--	--	<5.0
Hydroxide	mg/L	<5.0	--	<5.0	<5.0	<5.0	--	--	<5.0
Total Alkalinity (as CaCO ₃)	mg/L	7.5	--	9.0	153	<5.0	--	--	<5.0
Heterotrophic	CFU/mL	1055	523	--	2900	--	5200	7400	--
Total Coliform	MPN/100n	<2	<2	--	<2	--	<2	<2	--
Fecal Coliform	MPN/100n	<2	<2	--	<2	--	<2	<2	--
Total Hardness	mg/L	164	--	160	146	152	--	--	148
Turbidity	NTU	0.3	--	0.25	0.16	0.2	--	--	0.17
Color	Units	<5	--	<5	<5	<5	--	--	<5.0
Odor	TON	nd	--	nd	nd	nd	--	--	nd
Specific Conductance	umhos/cm	430	--	450	380	440	--	--	460
Methylene Blue	mg/L	<0.04	--	<0.04	<0.04	<0.04	--	--	<0.04
Ca	mg/L	48	--	46.8	42.7	44.3	--	--	43.3
Cu	mg/L	<0.01	--	<0.01	<0.01	<0.01	--	--	0.01
Fe	mg/L	0.047	--	0.051	0.307	0.211	--	--	0.023
Mg	mg/L	10.5	--	10.4	9.59	10.1	--	--	9.64
Mn	mg/L	<0.01	--	<0.01	<0.01	<0.01	--	--	<0.01
K	mg/L	1.47	--	1.67	1.61	1.55	--	--	1.59
Na	mg/L	33	--	25.7	24.2	25.4	--	--	24.7
Zn	mg/L	0.02	--	0.02	0.034	0.03	--	--	0.034

Parameter	Units	Test Period 2									
		Untreated (1)	Pretreated (2)	Lead (3)	Lag (4)	Treated (5)	Untreated (1)	Pretreated (2)	Lead (3)	Lag (4)	Treated (5)
Sample Location		1193	1193	1193	1193	1193	16115	16115	16115	16115	16115
Bed Volumes		6/15/06	6/15/06	6/15/06	6/15/06	6/15/06	7/10/06	7/10/06	7/10/06	7/10/06	7/10/06
Date		--	5.00	--	--	7.92	7.69	4.69	--	--	7.91
pH		--	8.1	--	--	--	8.1	7.9	--	--	--
Perchlorate	ug/L	--	29.6	--	--	--	34.8	34.7	--	--	32.6
Nitrate (as NO ₃)	mg/L	--	156	--	--	184	15.3	171	--	--	170
Sulfate	mg/L	--	10.7	--	--	10.6	11.4	11.3	--	--	11.7
Chloride	mg/L	--	0.17	--	--	0.17	0.24	0.19	--	--	0.21
Fluoride	mg/L	--	4.02	--	--	5.30	4.12	4.43	--	--	5.06
Anions	mEq/L	--	4.50	--	--	5.37	4.48	4.24	--	--	5.04
Cations	mEq/L	--	335	--	--	380	270	340	--	--	370
TDS	mg/L	--	<5.0	--	--	65.6	178	<5.0	--	--	40.5
Bicarbonate	mg/L	--	<5.0	--	--	<5.0	<5.0	<5.0	--	--	<5.0
Carbonate	mg/L	--	<5.0	--	--	<5.0	<5.0	<5.0	--	--	<5.0
Hydroxide	mg/L	--	<5.0	--	--	<5.0	<5.0	<5.0	--	--	<5.0
Total Alkalinity (as CaCO ₃)	mg/L	--	<5.0	--	--	53.8	146	<5.0	--	--	33.2
Heterotrophic	CFU/mL	747	--	>5700	>5700	--	1710	--	3192	4788	--
Total Coliform	MPN/100n	<2	--	<2	<2	--	<2	--	<2	<2	--
Fecal Coliform	MPN/100n	<2	--	<2	<2	--	<2	--	<2	<2	--
Total Hardness	mg/L	--	163	--	--	193	166	156	--	--	183
Turbidity	NTU	--	0.23	--	--	0.18	0.15	0.16	--	--	0.14
Color	Units	--	<5	--	--	<5	<5	<5	--	--	<5
Odor	TON	--	nd	--	--	nd	nd	nd	--	--	nd
Specific Conductance	umhos/cm	--	460	--	--	530	430	410	--	--	450
Methylene Blue	mg/L	--	<0.04	--	--	<0.04	<0.04	<0.04	--	--	<0.04
Ca	mg/L	--	48.4	--	--	60.2	49.1	45.6	--	--	55.7
Cu	mg/L	--	<0.01	--	--	0.011	<0.01	0.011	--	--	0.013
Fe	mg/L	--	0.021	--	--	0.016	0.872	0.063	--	--	0.58
Mg	mg/L	--	10.2	--	--	10.3	10.7	10.3	--	--	10.8
Mn	mg/L	--	<0.01	--	--	<0.01	<0.01	<0.01	--	--	<0.01
K	mg/L	--	1.79	--	--	1.75	1.61	1.62	--	--	1.66
Na	mg/L	--	27.6	--	--	34	25.6	24.8	--	--	30.6
Zn	mg/L	--	<0.01	--	--	<0.01	0.037	0.022	--	--	0.028

Parameter	Units	Test Period 3				
		Untreated (1)	Pretreated (2)	Pretreated (2)	Lead (3)	Treated (5)
Sample Location						
Bed Volumes		3691	3691	3691	3691	3691
Date		7/17/06	7/17/06	7/17/06	7/17/06	7/17/06
pH		--	--	--	--	7.62
Perchlorate	ug/L	8.1	9	8.7	<4	--
Nitrate (as NO ₃)	mg/L	--	--	--	--	35.4
Sulfate	mg/L	--	--	--	--	181
Chloride	mg/L	--	--	--	--	11.2
Fluoride	mg/L	--	--	--	--	0.14
Anions	mEq/L	--	--	--	--	5.44
Cations	mEq/L	--	--	--	--	6.15
TDS	mg/L	--	--	--	--	380
Bicarbonate	mg/L	--	--	--	--	48
Carbonate	mg/L	--	--	--	--	<5.0
Hydroxide	mg/L	--	--	--	--	<5.0
Total Alkalinity (as CaCO ₃)	mg/L	--	--	--	--	39
Heterotrophic	CFU/mL	--	--	--	--	--
Total Coliform	MPN/100n	--	--	--	--	--
Fecal Coliform	MPN/100n	--	--	--	--	--
Total Hardness	mg/L	--	--	--	--	210
Turbidity	NTU	--	--	--	--	0.16
Color	Units	--	--	--	--	<5
Odor	TON	--	--	--	--	nd
Specific Conductance	umhos/cm	--	--	--	--	530
Methylene Blue	mg/L	--	--	--	--	<0.04
Ca	mg/L	--	--	--	--	62.1
Cu	mg/L	--	--	--	--	<0.01
Fe	mg/L	--	--	--	--	0.1
Mg	mg/L	--	--	--	--	13.3
Mn	mg/L	--	--	--	--	0.027
K	mg/L	--	--	--	--	2.05
Na	mg/L	--	--	--	--	43.8
Zn	mg/L	--	--	--	--	0.015

Parameter	Units	Test Period 4					
		Untreated (1)	Pretreated (2)	Pretreated (2)	Lead (3)	Lag (4)	Treated (5)
Sample Location							
Bed Volumes		3072	3072	3072	3072	3072	3072
Date		7/24/06	7/24/06	7/24/06	7/24/06	7/24/06	7/24/06
pH		--	--	--	--	--	8.16
Perchlorate	ug/L	7.5	8.2	8.5	<4	<4	--
Nitrate (as NO ₃)	mg/L	--	--	--	--	--	32.8
Sulfate	mg/L	--	--	--	--	--	178
Chloride	mg/L	--	--	--	--	--	11.4
Fluoride	mg/L	--	--	--	--	--	0.15
Anions	mEq/L	--	--	--	--	--	5.09
Cations	mEq/L	--	--	--	--	--	5.66
TDS	mg/L	--	--	--	--	--	440
Bicarbonate	mg/L	--	--	--	--	--	33
Carbonate	mg/L	--	--	--	--	--	<5.0
Hydroxide	mg/L	--	--	--	--	--	<5.0
Total Alkalinity (as CaCO ₃)	mg/L	--	--	--	--	--	27
Heterotrophic	CFU/mL	--	--	--	--	--	--
Total Coliform	MPN/100n	--	--	--	--	--	--
Fecal Coliform	MPN/100n	--	--	--	--	--	--
Total Hardness	mg/L	--	--	--	--	--	215
Turbidity	NTU	--	--	--	--	--	0.19
Color	Units	--	--	--	--	--	<5
Odor	TON	--	--	--	--	--	nd
Specific Conductance	umhos/cm	--	--	--	--	--	550
Methylene Blue	mg/L	--	--	--	--	--	<0.04
Ca	mg/L	--	--	--	--	--	66.7
Cu	mg/L	--	--	--	--	--	<0.01
Fe	mg/L	--	--	--	--	--	0.032
Mg	mg/L	--	--	--	--	--	11.96
Mn	mg/L	--	--	--	--	--	<0.01
K	mg/L	--	--	--	--	--	2.07
Na	mg/L	--	--	--	--	--	29.9
Zn	mg/L	--	--	--	--	--	0.042

Parameter	Units	Test Period 5					
		Treated (5)	Untreated (1)	Pretreated (2)	Lead (3)	Lag (4)	Treated (5)
Sample Location							
Bed Volumes		392	11173	11173	11173	11173	11173
Date		7/27/06	8/14/06	8/14/06	8/14/06	8/15/06	8/14/06
pH		7.45	7.72	--	--	--	7.82
Perchlorate	ug/L	--	7.6	8	5.9	--	--
Nitrate (as NO ₃)	mg/L	7.6	32.6	--	--	--	33.6
Sulfate	mg/L	19.6	10.2	--	--	--	157
Chloride	mg/L	11	14.7	--	--	--	10.9
Fluoride	mg/L	0.1	0.15	--	--	--	0.14
Anions	mEq/L	4.8	4.19	--	--	--	4.36
Cations	mEq/L	4.65	4.49	--	--	--	4.62
TDS	mg/L	420	290	--	--	--	376
Bicarbonate	mg/L	18	187	--	--	--	15
Carbonate	mg/L	<5.0	<5.0	--	--	--	<5.0
Hydroxide	mg/L	<5.0	<5.0	--	--	--	<5.0
Total Alkalinity (as CaCO ₃)	mg/L	15	153	--	--	--	12
Heterotrophic	CFU/mL	--	570	--	6670	2340	--
Total Coliform	MPN/100n	--	<2	--	<2	<2	--
Fecal Coliform	MPN/100n	--	<2	--	<2	<2	--
Total Hardness	mg/L	171	166	--	--	--	172
Turbidity	NTU	0.18	0.18	--	--	--	0.21
Color	Units	<5	<5	--	--	--	<5
Odor	TON	nd	nd	--	--	--	nd
Specific Conductance	umhos/cm	510	390	--	--	--	470
Methylene Blue	mg/L	<0.04	<0.04	--	--	--	<0.04
Ca	mg/L	52.8	49.6	--	--	--	52
Cu	mg/L	<0.01	<0.01	--	--	--	<0.01
Fe	mg/L	0.031	0.011	--	--	--	<0.02
Mg	mg/L	9.52	10.1	--	--	--	10.1
Mn	mg/L	<0.01	<0.01	--	--	--	<0.01
K	mg/L	1.79	1.56	--	--	--	1.65
Na	mg/L	27.2	26.3	--	--	--	26.6
Zn	mg/L	0.034	0.014	--	--	--	0.019

Parameter	Units	Test Period 6			
		Untreated (1)	Pretreated (2)	Lead (3)	Treated (5)
Sample Location					
Bed Volumes		9200	9200	9200	9200
Date		9/1/06	9/1/06	9/1/06	9/1/06
pH		7.71	--	--	7.67
Perchlorate	ug/L	8.7	7.5	5.5	--
Nitrate (as NO ₃)	mg/L	30.2	--	--	29.9
Sulfate	mg/L	14.4	--	--	162
Chloride	mg/L	10.3	--	--	10.6
Fluoride	mg/L	0.17	--	--	0.15
Anions	mEq/L	4.09	--	--	4.41
Cations	mEq/L	4.46	--	--	4.94
TDS	mg/L	250	--	--	285
Bicarbonate	mg/L	184	--	--	15
Carbonate	mg/L	<5.0	--	--	<5.0
Hydroxide	mg/L	<5.0	--	--	<5.0
Total Alkalinity (as CaCO ₃)	mg/L	151	--	--	12
Heterotrophic	CFU/mL	--	--	--	--
Total Coliform	MPN/100n	--	--	--	--
Fecal Coliform	MPN/100n	--	--	--	--
Total Hardness	mg/L	160	--	--	179
Turbidity	NTU	0.18	--	--	0.16
Color	Units	<5	--	--	<5
Odor	TON	nd	--	--	nd
Specific Conductance	umhos/cm	350	--	--	380
Methylene Blue	mg/L	<0.04	--	--	<0.04
Ca	mg/L	48.6	--	--	55.9
Cu	mg/L	<0.01	--	--	<0.01
Fe	mg/L	0.036	--	--	0.232
Mg	mg/L	9.45	--	--	9.62
Mn	mg/L	<0.01	--	--	<0.01
K	mg/L	1.74	--	--	1.9
Na	mg/L	27.8	--	--	30.2
Zn	mg/L	0.016	--	--	0.02

4.4. Analyses provided by Department of Public Health - Los Angeles, CA

Condition	NDMA (ppt)		NMOR (ppt)	
	Lead (3)	Lag (4)	Lead (3)	Lag (4)
Reporting Limit (RL)	2	2	4	4
Virgin resin, startup @ 5BV	7	6.2	9	13.4
Test 1; 11,100 BV	<RL	<RL	<RL	<RL
Test 1; 15,000 BV	2.1	2.2	<RL	<RL
Test 2; after regen; 5BV	2.6	--	<RL	--
Test 5; 11,000 BV	<RL	<RL	<RL	<RL
Test 6; 24 BV	--	<RL	--	<RL

- Results for NDEA, NDBA, NDPA, NMEA, NPIP, and NPYR were below the detection limit (< 2-4 ppt)
- California DPH performed sampling and analysis

5. ARA QA/QC Results for analyzing Perchlorate

The quality control checks for perchlorate analysis are listed below. Every effort was made to comply with these criteria. If the criteria were not met, samples were re-analyzed on the next analysis day. It was especially challenging to meet the percent recovery goal for matrix spikes due to the very low perchlorate concentration in the groundwater, which was typically ≤ 8 ppb (matrix spike added was 10 ppb). For this reason, an alternate quality control plan was implemented using goals described by Standard Methods for the Examination of Water and Wastewater, 20th Edition, section 1020 B – Quality Control. This section recommends the use of accuracy (mean) control charts. These charts are constructed from the average and standard deviation of data gathered for the analyte of interest. The charts include upper and lower warning levels, which are set at ± 2 and ± 3 standard deviations, respectively. The quality control data for perchlorate analysis, including the accuracy, are provided on the following pages.

Quality Control Checks for Perchlorate Analysis

QC Check	Frequency	Criteria	Corrective Action
ICAL	Initially and as needed;	RSD <20%; EPA 314.0 criteria (see method)	Reanalyze calibration; prepare new standards as necessary
CCAL	Every 12 hours	RF <20% RPD,	Rerun CCAL standard; recalibrate if needed
Method blank	Every 12 hours	< RDL (for critical cpds)	Rerun; system maintenance
MS/MSD (Accuracy & Precision)	As per COC or 5%	% recovery 80-120; 20% RPD;	Reanalyze sample and spikes; if still fails, flag data; if LCS also fails - stop analysis and contact QAC
Field duplicates	As per sampling schedule	<u>Aqueous</u> RPD < 20 %;	Flag data

Perchlorate Quality Control Results

Analysis Date	ICAL (RSD, %)	CCAL (RPD, %)	Method Blank	Accuracy (% Recovery)	Precision (RPD) Dup. Analysis	Field Duplicates (RPD)
5/22/2006		3.2	<2.5 µg/L	127.9	3.0	--
5/24/2006	4.6	19.4	<2.5 µg/L	103.5	4.6	4.6
5/26/2006	12.3	11.2	<2.5 µg/L	148.0	15.4	15.4
6/5/2006	8.9	6.5	<2.5 µg/L	118.8	21.1	--
6/8/2006	9.7	9.1	<2.5 µg/L	154.6	1.1	21.1
6/14/2006	11.2	2.9	<2.5 µg/L	114.2	2.1	--
6/15/2006	3.7	8.7	<2.5 µg/L	99.5	2.3	--
6/22/2006	6.9	7.7	<2.5 µg/L	107.5	8.3	8.3
6/29/2006	10.7	10.1	<2.5 µg/L	95.8	0.7	0.7
7/6/2006	6.3	4.3	<2.5 µg/L	97.9	1.3	--
7/14/2006	19.6	15.7	<2.5 µg/L	71.0	1.0	1.3
7/17/2006	1.1	18.5	<2.5 µg/L	105.2	3.2	--
7/19/2006	4.8	13.7	<2.5 µg/L	112.2	0.5	--
7/24/2006	16.7	5.4	<2.5 µg/L	90.2	2.5	--
7/26/2006	9.2	4.6	<2.5 µg/L	107.3	0.8	--
8/1/2006	14.7	8.2	<2.5 µg/L	127.9	5.9	4.9
8/3/2006	13.7	4.5	<2.5 µg/L	147.5	4.9	--
8/10/2006	6.0	11.4	<2.5 µg/L	114.9	0.7	--
8/14/2006	6.3	13.9	<2.5 µg/L	106.1	4.7	4.7
8/16/2006	8.9	19.0	<2.5 µg/L	83.9	0.6	--
8/21/2006	13.4	28.2	<2.5 µg/L	152.8	1.3	--
8/28/2006	5.3	7.4	<2.5 µg/L	113.0	2.9	4.0
8/31/2006	4.4	18.0	<2.5 µg/L	96.3	13.4	13.4
9/8/2006	12.9	12.4	<2.5 µg/L	98.4	4.8	4.8
9/15/2006	19.6	3.1	<2.5 µg/L	149.7	1.9	--

Perchlorate Spike Control Chart for determining Accuracy

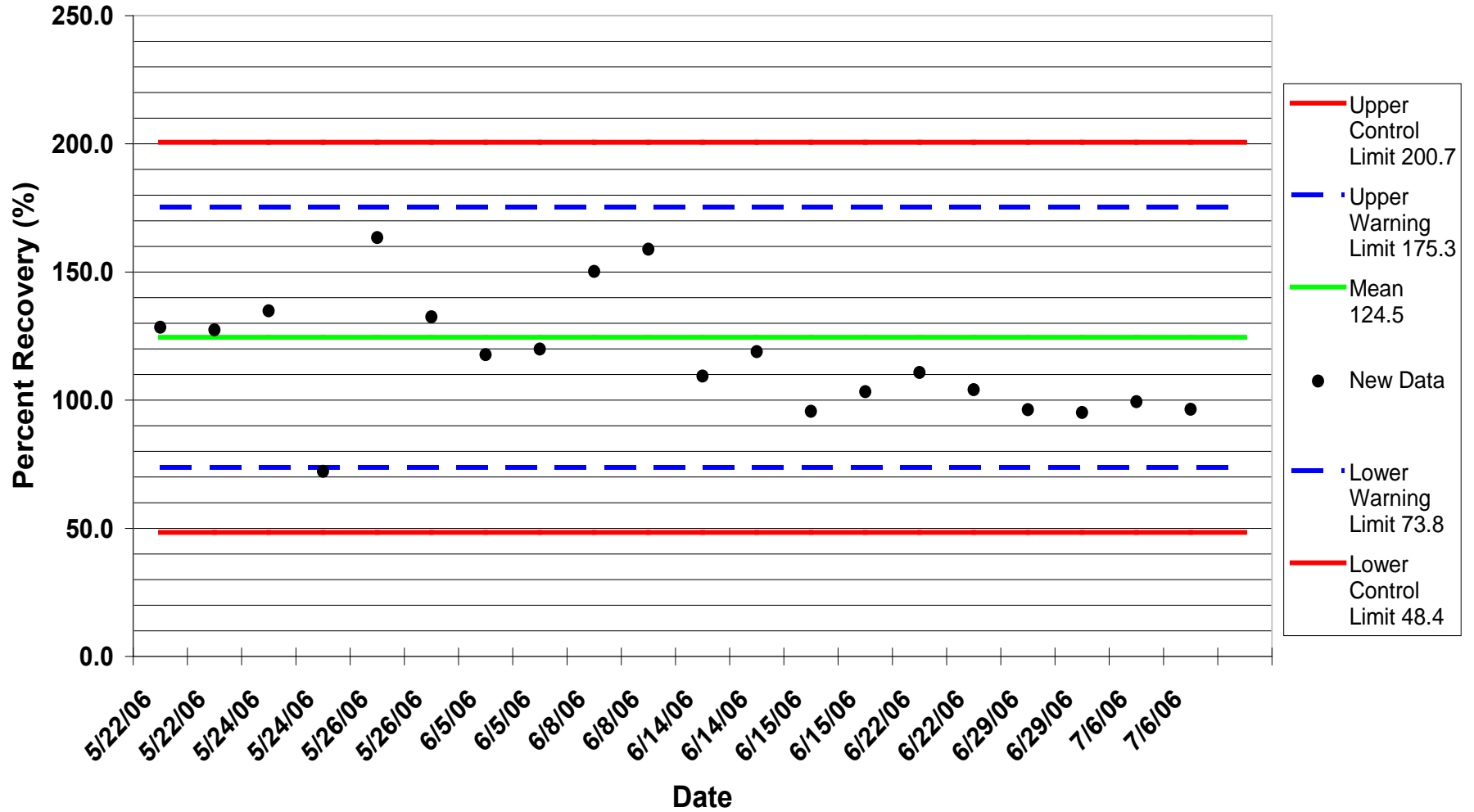

Perchlorate Spike Control Chart for determining Accuracy

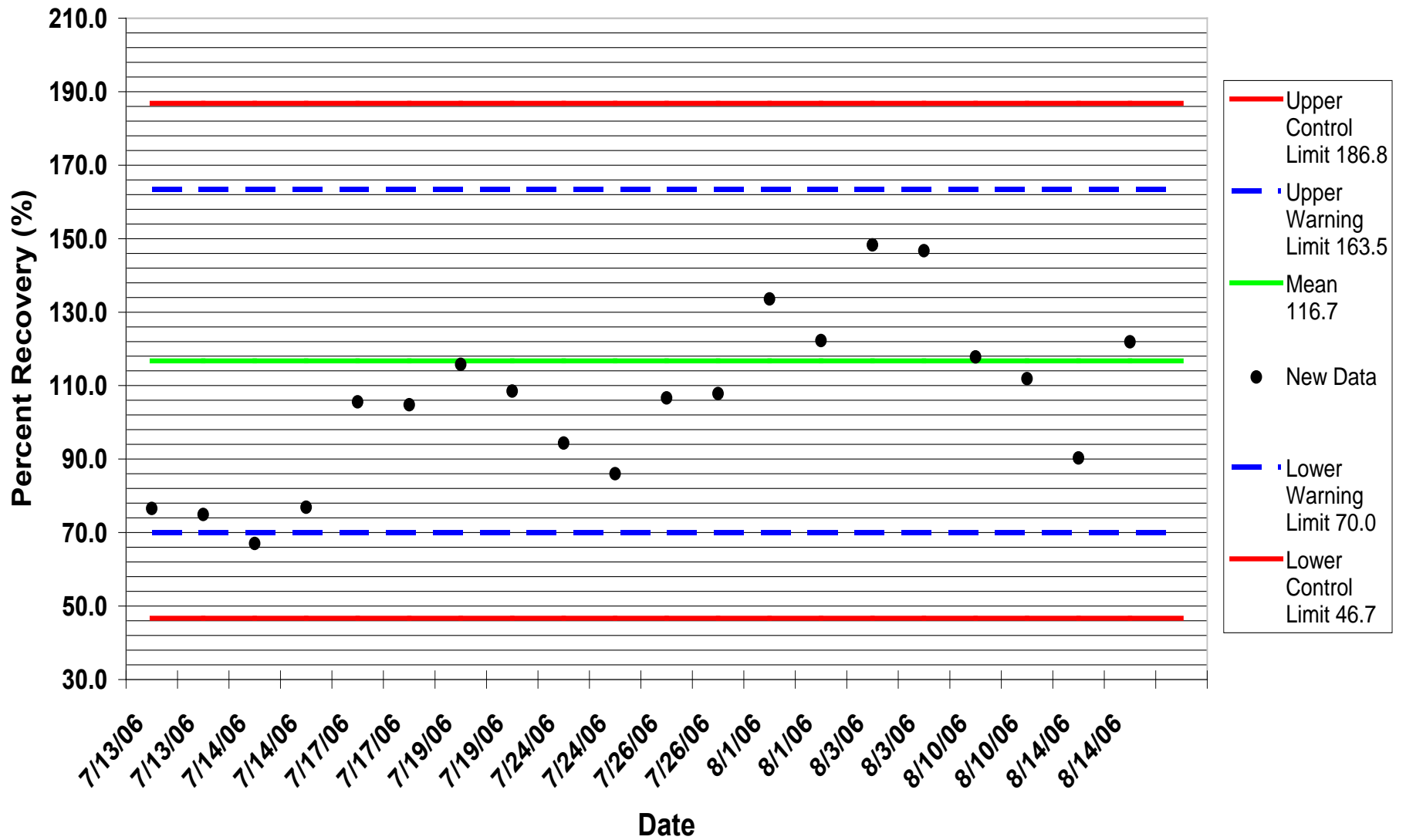

Perchlorate Spike Control Chart for determining Accuracy

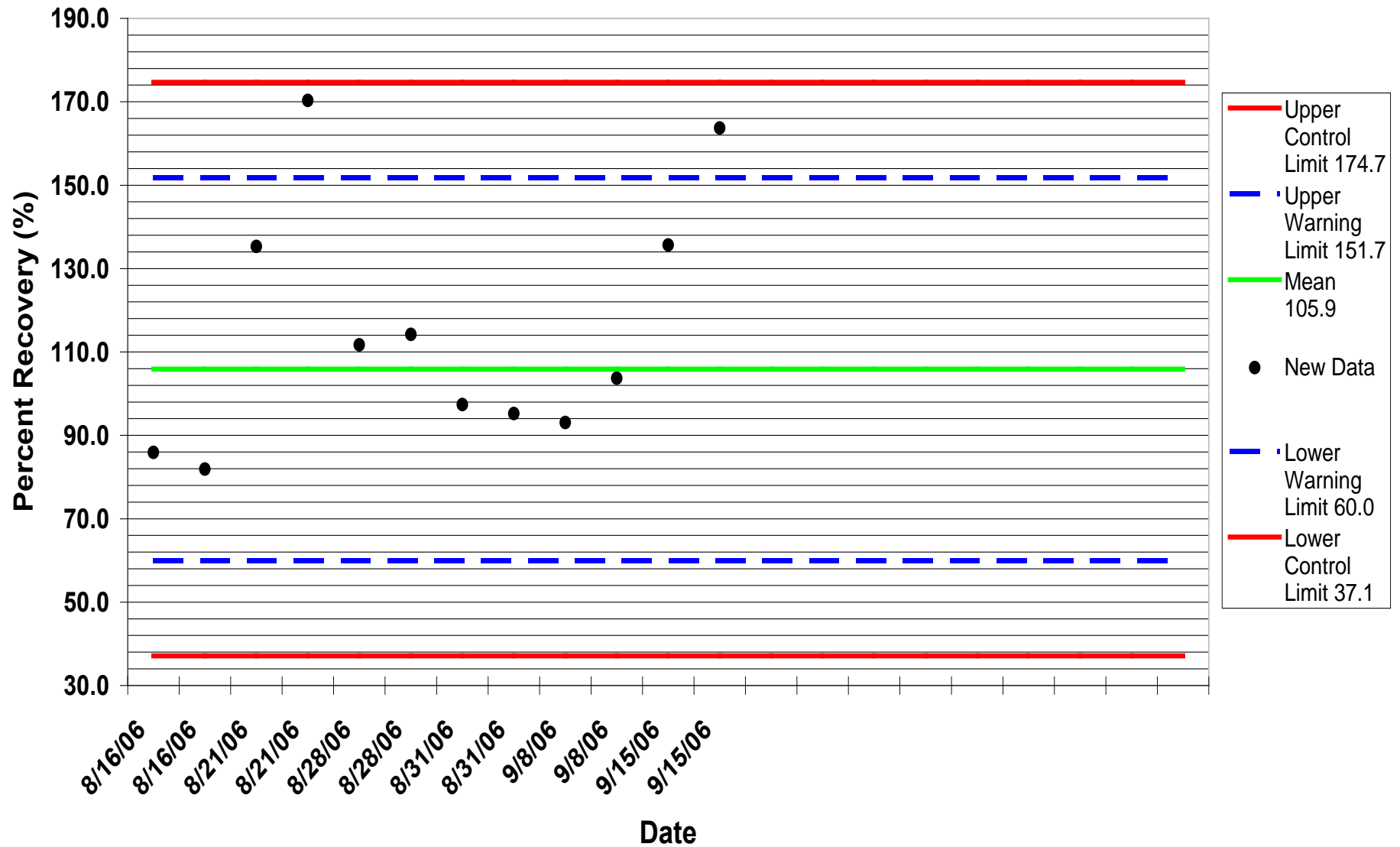

Appendix D

Cost Analysis of Strong Base Anion Resins for Selecting Scavenger Resin

**ESTCP PROJECT: ER-0312
ARA PROJECT: 16623 Phase 3**

A cost analysis of four strong base anion resins was conducted to determine the most cost-effective resin for use in the zero-discharge, perchlorate scavenging process. The strong base anion resins evaluated include Purolite resins A-600, A-530E, and A-520E, and Rohm and Haas resin PWA-2. The cost analysis is reported in the table below.

The resin capacities identified for A-600, A-530E, and PWA-2 were determined experimentally using a surrogate spent regenerant solution. This surrogate solution was prepared to represent predicted spent regenerant solution characteristics during the demonstration at Fontana well site F17 and had the following water qualities: perchlorate – 60 ppm; chloride – 80 ppm; nitrate – 3,000 ppm; and sulfate – 15,400 ppm. The resin capacity for A-520E was determined using a modeling and simulation program developed by Purolite using the same water qualities. The cost data for the resins were provided by vendors or from published information. A-530E was selected for use in the demonstration based upon the cost analysis.

Scavenger Resin	A-600	PWA-2	A-530E	A-520E
Capacity, meq/L	173	405	240	163
Capacity, meq/ft³	4899	11468	6796	4616
Volume, ft³/regeneration	3.53	1.51	2.54	3.74
Total Cost per ft³, \$	160	515	180	240
<i>Resin replacement, \$</i>	95	450	115	175
<i>Resin Handling, \$</i>	50	50	50	50
<i>Incineration, \$</i>	15	15	15	15
Cost per regeneration, \$	564	776	458	898
Cost per acre-foot, \$	5.27	7.24	4.27	8.39

Appendix E

Health and Safety Plan

for the

ESTCP Field Demonstration

at

Fontana Water Company – Fontana, California

March 30, 2006

**ESTCP PROJECT: ER-0312
ARA PROJECT: 16623 Phase 3**

Approvals

The undersigned have read and understand the pertinent health and safety procedures and plans applicable to this site.

Andrea Davis
ARA Project Manager

Jeff Rine
ARA Field Manager

Robert Girvin
ARA Health and Safety Reviewer

1. Introduction

1.1 Scope and Applicability

This Health and Safety Plan (HASP) applies to field activities conducted by Applied Research Associates, Inc (ARA) in support of the ESTCP Field Demonstration at Fontana Water Company (FWC), Fontana, California. The information provided in this plan was developed for the purpose of assigning responsibilities, establishing personal protection standards and mandatory safety procedures, and to provide for contingencies that may arise while operations are being conducted by personnel supporting the ESTCP Field Demonstration at FWC. ARA disclaims responsibility for any other use of this information other than the express purpose for which it is intended and assumes no liability for the use of this information for any other purpose. The evaluations of potential hazards and their controls reflect professional judgments subject to the accuracy and completeness of information available when the plan was prepared. The plan is written for specific site conditions, purposes, dates, and personnel, and must be amended if conditions change during the course of the demonstration.

1.2 Demonstration Work Scope Overview

This demonstration will evaluate and demonstrate the performance of selective weak base ion exchange resin in removing perchlorate from contaminated drinking water and demonstrate efficient removal/destruction of perchlorate in spent regenerating solutions. The project and objectives have been fully described in the Demonstration Plan and the Quality Assurance Project Plan (QAPP). This HASP is designed to cover operation, sampling and related activities during the field demonstration at the site and to assure safe and healthful working conditions. The following items are covered in the HASP:

- Project Organization and Responsibilities
- Task Description
- Hazard Analysis
- Hazard Monitoring and Control
- Emergency Response
- Spill Containment
- Recordkeeping

2. Project Organization and Responsibilities

2.1 Project Organization

The ARA project team will consist of Ed Coppola, Steve Baxley, Jeff Rine, Andrea Davis, and Robert Girvin. The project manager is ultimately responsible for the well being of all field personnel under his supervision. To assist him with health and safety related issues and activities, he will designate a Site Safety Coordinator (SSC) to ensure that the HASP is implemented. The SSC has the authority to stop project activities or evacuate the site if hazardous conditions are encountered or if any operation threatens work personnel/public health or safety.

The Field Manager, also appointed by the project manager, is responsible for directing field activities and ensuring that personnel follow all sampling and analysis protocols. The Field Manager defers to the SSC for health and safety and compliance. Additional responsibilities for ARA project management personnel and support staff are described in the ARA Environmental Compliance and Health and Safety (EC&HS) Program Manual.

Key personnel, and their responsibilities for the Field Demonstration at FWC are identified in the QAPP, which is a component of the overall Field Demonstration Plan. The ARA Environmental Compliance and Health and Safety Manual specifies the health and safety responsibilities for the Project Manager, Andrea Davis, and the Health and Safety Officer (HSO), Mr. Lew Vereen; therefore these positions are not described here.

2.2 Responsibilities

All persons involved in this demonstration shall read and sign this safety plan prior to performing field investigation activities at Fontana Water Company in Fontana, California. Through their signature, personnel indicate that they understand and will adhere at all times to ARA and OSHA requirements presented or referenced in this plan. The designated project manager will hold a master copy (with signature sheet) of this plan and a copy will be available at the work site. In addition, all personnel will sign a master signature sheet (Attachment 1) upon arrival, acknowledging that each individual has read, understands, and will comply with the requirements of this Health and Safety Plan. The health and safety-related responsibilities of the various personnel involved in this project are described in the paragraphs below.

Field Manager: The Field Manager is responsible for supervision of all activities when on-site, and for compliance with Quality Assurance (QA) and safety requirements. The demonstration is designed for periods of unattended operation, during which operation variables including pressure, pH, total flow rate, and perchlorate concentration will be monitored remotely. At least once per week, the Field Manager will carry out sampling and system maintenance. The health and safety responsibilities of the Field Manager during site visits include the following:

- Report any health and safety violations or incidents to the project manager and Site Safety Coordinator (SSC). A copy of an incident report form is provided in Attachment 2. The incident report includes the following information:
 1. Date, time, and place of occurrence;
 2. Person(s) involved;
 3. Type of incident;
 4. Description of incident and action taken; and
 5. Recommendations to prevent a similar occurrence.

Site Safety Coordinator: The Site Safety Coordinator (SSC) will oversee the safety activities associated with the project. Mr. Robert Girvin will serve as the SSC for the field demonstration project at Fontana Water Company. His specific responsibilities will include:

- Participating in the preparation and implementation of the HASP and assuring that all personnel have access to the HASP;
- Conducting routine inspections to assure that all the requirements of the HASP are rigorously followed throughout the field activities and documenting environmental compliance and health and safety violations, deviations from the HASP, and hazardous conditions;
- Conducting safety meetings, as necessary, for all site personnel, and completing the Site Safety Briefing Report;
- Halting ARA site operations, if necessary, in the event of an emergency or to correct unsafe work practices;
- Consulting with the Health and Safety Officer before making any amendments to the HASP. The amendments may include upgrading or downgrading PPE, air monitoring for specific compounds, air monitoring frequency, etc.
- Ensuring that protective clothing and equipment are properly used and maintained;
- Overseeing the record keeping for occupational illnesses and injury, individual site assessments, and exposure and monitoring results;
- Obtaining and coordinating emergency assistance;
- Monitoring site conditions and, if determined to be unsafe, authorizing the temporary suspension of operations until the unsafe circumstances have been resolved;

- Preparing and submitting incident reports;
- Ensuring that personnel conducting the field activities have completed the appropriate training and have received medical clearance as applicable; and
- Conducting a post-field activity briefing at the end of the project to identify problems encountered and lessons learned, and preparing a record summarizing actions taken to ensure compliance with applicable requirements at the site.

Field Team Members: All field team members will be comprised of personnel approved by ARA and FWC. All field team members are responsible for protecting their own health and safety to the best of their abilities and each assumes the following responsibilities:

- Review and sign the HASP;
- Wear and maintain personal protective equipment as specified in the HASP;
- Abide by the rules presented in the site HASP and maintain possession of the plan while at the site;
- Take all precautions to prevent injury to themselves and their coworkers and have a thorough knowledge of specific emergency response procedures for their specific work sites;
- Perform only those tasks that they believe they can do safely; and
- Notify the Project Manager and Site Safety Coordinator of any health and safety hazards or violations observed or inadequately controlled by procedures contained in the HASP.

3. Task Description

3.1 Project Objectives

This project will evaluate and demonstrate the performance of selective ion exchange resins in removing perchlorate from contaminated drinking water and demonstrate the efficient removal and destruction of perchlorate in spent regenerating solutions. Detailed objectives can be found in the Demonstration Plan.

3.2 Field Activities

This HASP covers field activities associated with the ion exchange technology demonstrated by ARA at Fontana Water Company. The ion exchange system and field monitor with associated equipment will be constructed and integrated together at ARA's Panama City Research Facility. Once constructed, the system will be installed in an eight by twenty feet enclosed mobile trailer, and a series of functional tests will be performed prior to field mobilization. After sufficient functional testing the mobile pilot system will be transported and put in place, adjacent to the selected well head, at Fontana Water Company. The enclosed trailer will provide breaker power, climate control, and protection from the elements while in the field. Since the main components of the process are contained within the trailer setup at the site should go relatively smooth and quick.

It is anticipated that the system will be manned full time for a set-up and start-up period (~ 2 weeks). Following this start-up period, a data acquisition system will be used to allow remote monitoring of real-time, key performance parameters (i.e. operation pressures, pH, total flow, and perchlorate concentrations). Site visits will be conducted at least once every week for split sampling and system check/maintenance. Arrangements have been made for an on-sight technician who can rapidly respond to operational or data acquisition anomalies. This technician may also conduct unscheduled site visits following power failure due to thunderstorms or other unforeseen events to inspect and ensure system operation. The following table describes expected activities that may be conducted during site visits.

Table 3-1. Field Activity Examples

Field Activity	Description
System Inspection	Upon arrival and departure, visually inspecting exterior and interior of trailer for anomalies or damages. Securing trailer.
Equipment Inspection / Calibration	Ensuring all pumps, pressure gauges, flow totalizers, pH meters, etc, are operating properly. Calibrating, if necessary.
Maintenance	Checking fluid levels of required solutions and adding more, if needed
Sampling	Collecting groundwater and effluent samples
Column Regeneration	Regenerating a spent column by passing over a basic regenerating solution over the column and collecting the effluent
Column Protonation	Re-protonating the regenerated column by passing over an acidic regenerating solution over the column and collecting the effluent
Column Exchange	Replacing a spent column with a regenerated column

4. Hazard Analysis

4.1 Potential Chemical Exposures

Based upon the proposed work plan for the field demonstration, the primary chemicals of concern are acids and bases used for operational control of the process and for the regeneration of protonation of the ion exchange resin. The specific chemicals of concern are:

- Sulfuric Acid
- Hydrochloric Acid
- Sodium Hydroxide

The chemicals and compounds listed above pose potential health hazards via inhalation, dermal contact or absorption, and ingestion. Some are also suspected or known to be carcinogenic, mutagenic, or toxic. Dermal exposure may result in skin and mucous membrane irritation, as well as internal injury or illness due to absorption. Dermal protection is accomplished by limiting contact with material through the use of personal protective equipment (PPE), and by decontamination and personal hygiene protocols. Ingestion hazards are controlled by strict limitations on eating, drinking, smoking, and by rigorous application of decontamination and personal hygiene protocols. The exposure limits for chemical hazards that may be encountered during the execution of the field demonstration at FWC are given in Table 4-1. The specific types of PPE that will be used are discussed in Section 5.2.

Table 4-1. Chemical and Physical Properties for Chemicals of Primary Concern

Contaminant	PEL (ppm)	TLV (ppm)	Skin Notation (Yes/No)	Vapor Pressure @ 23° C & 760 mm Hg	IDLH (ppm)	Flash Point (°F)
Sulfuric Acid	1000	200	Yes	1	15,000	ND
Sodium Hydroxide	2000	2000	Yes	14	10,000	ND

NA = Not Available ND = None

4.2 Radiological Hazards

No radiation hazards have been reported for the site and none are expected for the sampling activities.

4.3 Physical Hazards

The physical hazards that may be encountered during the field activities include hazards associated with:

- Existing objects and terrain;
- Lifting heavy objects;
- Personal protective equipment;
- Solar non-ionizing radiation; and
- Other physical hazards.

Existing Objects and Terrain: Existing objects and terrain can present hazards in the form of:

- **Holes, ditches and canals;**
- **Precariously positioned objects (e.g., drums, cables, boards) that may fall or cause an individual to trip;**
- **Sharp objects and rubble such as nails, metal shards, rebar, and broken glass; and**
- **Slippery surfaces.**

Lifting Heavy Objects: Personnel may be exposed to injury caused by lifting heavy objects. Mechanical and hydraulic assists as well as a helper will be used whenever possible to minimize lifting dangers. Useful guidelines for lifting include:

- If possible, lift with your legs, not your back, but always maintain a stable, comfortable posture;
- Lift heavy objects slowly and deliberately, not with a grab and jerk motion; and
- Avoid turning while lifting; turn while you are erect.

Personal Protective Equipment: Personal protective equipment can restrict visibility and movement. This increases the risk of tripping, falling over, falling into floor openings, or striking, or being struck by objects. Personal protective equipment increases the risk of heat stress and reduces workers' ability to move freely and hear direction and noise that might indicate a hazard. This potential hazard will be addressed specifically during safety discussions.

4.4 Other Physical Hazards

Other physical hazards include heat stress, which is a concern especially in summer months. Exposure to hot temperatures increases the likelihood and potential for worker disorders or conditions that could result in injury or illness. Extreme high temperatures may not be the only element necessary to create the potential for heat exposure disorders or conditions; strong wind accompanied by cold temperatures can also lead to illness or injury. Common heat disorders or conditions include heat stroke and dehydration. Contributing factors to these disorders or conditions are:

- Elevated Temperatures;
- Exposure to humidity;

- Inadequate fluid intake;
- Inappropriate clothing; and
- Poor worker health.

The SSC should monitor daily weather conditions and prescribe appropriate clothing and work-rest schedules as required to minimize the possibility of heat stress-related problems. In addition adequate fluid will be made available for worker to remain full hydrated. Table 4-2 gives the recommended time limits for working in various low temperature ranges.

Table 4-2. Maximum Daily Time Limits for Exposure at High Temperatures

Temperature Range		Maximum Daily Exposure
Celsius	Fahrenheit	
0 to 38	32 to 100	No limit, providing that the person is properly clothed and hydrated
>38	>100	Total work time: 8 hours. Alternate 1 hour in and 1 hour out of the high-temperature area.

Early recognition of symptoms associated with heat exposure is essential in preventing serious or permanent disorders or even death. Workers and managers involved in hot weather operations should be adequately trained to recognize the following conditions and related symptoms:

- Heat Stroke - The symptoms of this condition are fatigue, dizziness, nausea or vomiting, headache, shallow or rapid breathing, high body temperature (106-112), rapid heart beat, and decreased alertness or loss of consciousness. Severe shaking of rigid muscles may be caused by a burst of body energy and changes in the body's chemistry. Vague or slow, slurred speech, memory lapses, incoherence, and drowsiness are some of the additional symptoms. Symptoms noticed before complete collapse is dry and hot skin, shallow and rapid breathing, apparent exhaustion, and fatigue even after rest. As the core body temperature rises, the victim may become listless and confused, and may make little or no attempt to keep cool off. Pain in the extremities can be the first warning of dangerous exposure to heat. If the body core temperature increases to above 106° F, a significant and dangerous reduction in the blood pressure, and increases in pulse rate and respiration can occur. In extreme cases, death may occur.
- Dehydration - can occur, in absence of heatstroke, when the body does not receive sufficient fluid to replenish the liquid exhausted by sweating. The symptoms are dry lips and tongue, apathy and lack of energy, muscle cramping and bright colored or dark urine.

The potential for both heat and cold related disorders or conditions can occur in many common situations. Cold early morning temperatures can give way to warm daily temperatures, resulting in heavy perspiration within protective clothing. As temperatures cool again in the evening, the potential for cold related disorders or conditions can occur. Managers should be aware of the potential for this occurrence and should monitor workers accordingly.

Other physical hazards include noise, and wet conditions that could present slipping or falling hazards. There is also machine related hazards (i.e., clothing getting caught in the pumps.)

4.5 Task Hazard Analysis

The site activities will be intrusive, and the potential hazards associated with the sampling activities include inhalation hazards, dermal exposure, cold and heat stress, and noise physical hazards associated with the operation of the pilot system. Table 4-3 provides a task hazard analysis for the field activities to be conducted at Fontana Water Company.

Table 4-3. Task Hazard Analysis

FIELD ACTIVITY	POTENTIAL HAZARD	HAZARD CONTROL MEASURES	PROTECTIVE EQUIPMENT
Non-Intrusive Work (site walkovers, field survey, site preparation for intrusive activities)	Slips, trips, falls	<ul style="list-style-type: none"> • Watch where you are stepping • Avoid areas of debris, thick vegetation • Use caution when walking near steep slopes 	Work in Level D (standard work clothes) personal protective equipment (PPE) except in site locations where Level C is required. Any changes in the level of PPE required based on site conditions.
	High or low ambient temperatures	<ul style="list-style-type: none"> •Wear proper work clothes •Monitor for heat (if wearing impermeable protective ensemble) or cold stress 	
System Setup and Transport	Slips, trips, falls	<ul style="list-style-type: none"> • Watch where you are stepping • Avoid areas of debris, thick vegetation • Use caution when walking near steep slopes 	Work in Level D PPE (standard work clothes). Any changes in the level of PPE required based on site conditions, such as the potential for contact with visibly contaminated surfaces or waters, will be the responsibility of the designated SSHO.
	Machinery and rotating equipment	<ul style="list-style-type: none"> • Avoid standing near operating/rotating drilling equipment • Avoid turning back on operating drill rig • Stand far enough away from operating machinery to prevent accidental contact that could result from mechanical or human error. 	
	Overhead and underground utilities	<ul style="list-style-type: none"> • Keep operating equipment clear of overhead utility lines or other overhead hazards. For electrical wires less than or equal to 50 kV keep a minimum clearance of 10 feet. For electrical line greater than 50 kV, maintain a minimum clearance of 10 feet plus 0.4 inches per kV above 50 kV. • Contact dig-safe and local/site utility representatives to locate/mark underground utilities prior to excavating 	
	Dermal contact and inhalation of hazardous substances	<ul style="list-style-type: none"> • Work in well ventilated area and monitor breathing zone of work area for hazardous chemical vapors, mix chemicals with proper ventilation. • Utilize Modified Level D PPE if dermal contact hazard (See Section 5.2 for description of PPE) • Utilize Level C PPE including full-face APR, chemical resistant gloves, boots, and coveralls if inhalation hazard cannot be controlled (See Section 5.2 for description of PPE) 	

FIELD ACTIVITY	POTENTIAL HAZARD	HAZARD CONTROL MEASURES	PROTECTIVE EQUIPMENT
	Handling heavy objects	<ul style="list-style-type: none"> Observe proper lifting techniques Obey sensible lifting limits Use mechanical lifting equipment to move large, awkward loads 	
	Sharp objects	<ul style="list-style-type: none"> Wear cut resistant work gloves when possibility of lacerations or other injury from sharp objects exists Maintain all hand and power tools in a safe condition 	
	High noise levels	<ul style="list-style-type: none"> Use hearing protection when exposed to high noise levels (i.e., rule of thumb – when necessary to raise one’s voice to communicate with others three to five feet away). 	
	Low ambient temperature	<ul style="list-style-type: none"> Wear proper work clothes Monitor for cold stress 	
System Sampling	Slips, trips, falls	<ul style="list-style-type: none"> Watch where you are stepping Avoid areas of congestion, piping, hoses Use caution when walking near slippery, wet conditions 	Work in Level D PPE (standard work clothes). Any changes in the level of PPE required based on site conditions, such as the potential for contact with visibly contaminated surfaces or waters, will be the responsibility of the designated SSHO.
	Sharp objects	<ul style="list-style-type: none"> Wear cut resistant work gloves when possibility of lacerations or other injury from sharp objects exists Maintain all hand and power tools in a safe condition 	
	High ambient temperature	<ul style="list-style-type: none"> Wear proper heat stress 	
	Dermal contact and inhalation of hazardous substances	<ul style="list-style-type: none"> Work in well ventilated area and monitor breathing zone of work area for hazardous chemical vapors, mix chemicals with proper ventilation. Utilize Modified Level D PPE if dermal contact hazard (See Section 5.2 for description of PPE) Utilize Level C PPE including full-face APR, chemical resistant gloves, boots, and coveralls if inhalation hazard cannot be controlled (See Section 5.2 for description of PPE) 	
IX Column Regeneration/Protonation	Slips, trips, falls	<ul style="list-style-type: none"> Watch where you are stepping Avoid areas of congestion, piping, hoses Use caution when walking near slippery, wet conditions 	Work in Level D PPE (standard work clothes). Any changes in the level of PPE required based on site conditions, such as

FIELD ACTIVITY	POTENTIAL HAZARD	HAZARD CONTROL MEASURES	PROTECTIVE EQUIPMENT
	Dermal contact with hazardous substances	<ul style="list-style-type: none"> • Work in well ventilated area • Utilize Modified Level D PPE if dermal contact hazard (See Section 5.2 for description of PPE) • Utilize Level C PPE including APR, chemical resistant gloves, boots, and coveralls if inhalation hazard cannot be controlled (See Section 5.2 for description of PPE) 	the potential for contact with visibly contaminated surfaces or waters, will be the responsibility of the designated SSHO.
	Sharp objects	<ul style="list-style-type: none"> • Wear cut resistant work gloves when possibility of lacerations or other injury from sharp objects exists • Maintain all hand and power tools in a safe condition 	
	High ambient temperature	<ul style="list-style-type: none"> • Wear proper heat stress 	

5. Hazard Monitoring and Control

5.1 Training

All personnel who perform field activities during the demonstration at the Fontana Water Company must be familiar with the operation and maintenance procedures of the field demonstration system. All personnel, including ARA subcontractors, performing site activities must be trained on the operation of the system. See Section 8 (RECORDKEEPING) for additional details.

In addition, a safety meeting conducted by the site safety officer shall be held prior to field activities to reiterate the health and safety requirements or to inform site personnel of upcoming operations and safety requirements.

5.2 Personal Protective Equipment

Personal protection requirements for personnel will be established at Level D based on an initial assessment of hazards at the site. Level D protection is the minimum basic work uniform worn for any site operation and will be used at all times by on-site personnel engaged in sampling when working at the site. The Level D protection scheme for conditions at FWC consists of the following protective equipment:

- Chemical resistant gloves shall be worn if environmental samples or contaminated equipment are handled (Granet; Nitrile 492)
- Safety Glasses shall be worn while operating machinery or sampling
- Chemical-resistant boots or closed toe, leather shoes (personal work boots or leather shoes without cloth) shall be worn at all times
- Chemical-resistant lab coats shall be worn if environmental samples or contaminated equipment are handled
- Ear Plugs will be worn as necessary

An upgrade to Level C protection is warranted under the following three conditions:

- When air purifying respirators can sufficiently protect personnel from the chemicals
- When IDLH concentrations of suspected chemicals are not expected
- When exposure of unprotected area of the body (i.e., neck and back of head) to the chemical is not likely to cause harm.

Level C protection consists of the following personal protective equipment:

- Full-face air-purifying respirator (APR) with organic vapors/HEPA cartridges
- Tyvek coveralls

- Vinyl inner gloves
- Chemical-resistant steel-toed boots and disposable boot covers, if necessary
- Hard hat
- Hearing protection (ear plugs/ear muffs).

The sampling team will use Level C protection if a respiratory hazard due to dust and/or chemical/hydrocarbon vapor is determined to be present. If organic vapors exceed 50 ppm in the breathing zone, all personnel shall leave the site and contact the ARA Program Safety Officer for direction. At that time, the ARA Project Manager and Program Safety Officer will evaluate the situation. It is expected that Level D or Level C protection will be adequate for all field activities conducted for this project. The use of Level B protection is not authorized by this plan. If the SSC determines that Level C is insufficient per the requirements in this section, the field team will withdraw from the site and a revised HASP will be prepared.

A full complement of spare protective equipment will be kept at the site so that damaged or malfunctioning equipment can be replaced immediately.

5.3 Emergency Equipment

In spite of safety and health training, the use of appropriate protective equipment, and exercise of due caution by members of the site teams, the possibility exists for injury and illness in the field. In order to provide emergency assistance to sick or injured workers, the following supplies and equipment will be available on site:

- Potable water or Gatorade with ice (one to two gallons per person);
- First aid kit containing supplies for initial treatment of minor cuts and abrasions, severe lacerations, shock, heat stress, eye injuries, skin irritation, thermal and chemical burns, snake and insect bites, and immobilization of fractures;
- Cellular phones; and a
- Fire Extinguisher.

5.4 Monitoring and Sampling Plan

The sampling events associated with the demonstration are planned for an open environment with adequate ventilation. Therefore, no planned air sampling and air monitoring events are planned. If deemed necessary, occupational noise levels will be measured using a sound level meter during drilling activities and ambient air monitoring may be performed with the following equipment:

- PID - HNu system portable PID equipped with an 11.7 electron volt UV lamp. This instrument shall be maintained and calibrated every day according to the Mini RAE operations manual;
- Combustible gas indicator (CGI);
- Carbon monoxide detector;

- Personal air sampling pumps with filter cassettes; and a
- Sound level meter.

If air monitoring is deemed necessary, air monitoring logs will be maintained. These logs will contain the names of all personnel performing work at the site, a description of the work being performed at the site, and any new procedures established for performing work. In addition, these logs will list the types of air monitoring equipment being used; how and when this equipment was calibrated; air monitoring results; the level of personal protective equipment being used; and complete descriptions of all injuries, accidents, physical complaints, and unusual occurrences. Table 5-1 lists the site actions that are required for detected concentrations for each detection instrument.

Table 5-1. Action Limits for Site Contaminants

Monitoring Instrument	Detected Concentration	Site Action
PID/FID	> 5 ppm for 1 minute	Upgrade PPE to Level C
PID/FID	> 50 ppm for 1 minute	Leave site and contact HSO
CGI	10 percent LEL	Leave site and contact HSO
Personal Air Samples	0.05 f/cc	Upgrade PPE to Level C

5.5 Site Control Measures

Personnel may be required to work alone during the performance of sampling activities. As a safety measure, a cellular phone will be available on site to summon emergency assistance. If personnel are on site alone, they will notify the Field Manager or Site Safety Coordinator. Other site control measures include the following:

- The initial indoctrination of site personnel and site-specific safety training will be accomplished during a training session conducted by the SHSO. In addition, site personnel will receive a site orientation and review of the HASP.
- Emergency phone numbers (Provided in Attachment 3) for the fire department, ambulance service, nearest medical clinic/hospital, along with the quickest traveling route to the hospital shall be available.
- A tailgate safety meeting will be conducted at the beginning of each shift, whenever new personnel arrive at the job site, as site conditions change, or when deemed necessary. They will be conducted by the Field Manger or Site Safety Coordinator to discuss pertinent site safety topics.
- The SSC will ensure that appropriate PPE is available and used and described in Section 4 of this HASP.

- ARA will emphasize compliance with state, local, and motor vehicle laws and regulations. Special considerations such as current or anticipated hazardous road conditions will be addressed.

5.6 Decontamination Plan

It is not expected that personnel or equipment performing investigative activities on this site will become contaminated to concentrations considered hazardous. However, to ensure that potential contaminants are not carried offsite, the following decontamination procedures shall be implemented.

Level D Decontamination: Site sampling tasks at the site will be conducted in Level D protection unless criteria for upgrading to Level C protection are exceeded. Personnel decontamination is required prior to crossing the designated hotline at the entry/exit point of the exclusion zone, and will consist of the following:

- When exiting the exclusion zone prior to crossing the hotline, personnel shall remove overboots, disposable coveralls and outer work gloves. This will entail removal of protective clothing in an “inside out” manner. Removal of contaminants from clothing or equipment by blowing, shaking, or any other means that may disperse material into the air will be prohibited. The coveralls and gloves are disposed of in a plastic bag. Rubber overboots may be left at the decon station for re-use in the area during the next sampling activity.
- Monitoring equipment including personal sampling pumps and ring badges/dosimeters will be removed and rinsed or wiped down with soap and water.
- Personnel will not be permitted to exit the exclusion zone until they have washed their hands and face with soap and water.
- At the conclusion of work in a site exclusion zone, all protective equipment will be placed in plastic bags for proper disposal or transfer off site.

Level C Decontamination: This decontamination procedure will follow the same discussed above for Level D decontamination, with the air-purifying respirator (APR) being the last item removed prior to exit from the exclusion zone. The respirator will be cleaned with a solution of soap and water, and the cartridges will be disposed of if the existing cartridges are loaded with particulate or wetted during decontamination.

5.7 Sanitation

Sanitary toilet facilities and potable water will be provided for all field personnel at Fontana Water Company by the existing facilities, adjacent to the test site.

5.8 Confined Space Entry Plan

There will be no confined space entry requirements during this project. ARA personnel are not authorized to conduct any confined space entries.

5.9 Enforcement of the Site Specific Health and Safety Plan

5.9.1 Inspections

The SSC is responsible for ensuring that the HASP is being effectively implemented. The SSC will document the following, at a minimum:

- Verification that all ARA field personnel are in compliance with OSHA regulations for hazardous waste site work;
- Verification that PPE is being properly used; and
- Documentation of any deficiencies and actions taken to correct the deficiencies.

5.9.2 Audits

The ARA Health and Safety Officer or a representative will be onsite initially to evaluate compliance with the HASP. No audits by ARA are planned. If an independent inspection is conducted by a regulatory agency while ARA is on site, ARA personnel should follow the instructions in ARA EC&HS Procedure 24 - Regulatory Agency Inspections and Incident Reporting.

5.9.3 Project Debriefing

The project manager will conduct a debriefing with ARA site personnel to identify any problems that may have arisen during the inspection. This briefing will include any deviations from the HASP, reasons for the deviations, and potential risk to site personnel.

The debriefing will be prepared by the SSC by completing the Hazardous Waste Site Task/Project Debriefing Questionnaire (Attachment 4) and be reviewed by the project manager within 30 days of the date of the last activity at the site.

5.9.4 Health and Safety Plan Amendments

It is not anticipated that the HASP will require changes. If field conditions are different than anticipated or other conditions change, this plan may be amended by completing a Field Change Request Form, included in Attachment 5.

6. Emergency Response

6.1 Site Emergency Response

The types of emergencies that could occur include the following:

- Heat stress related illnesses;
- Injuries from Slips, trips, or falls;
- Motor vehicle-related accidents or injuries;
- Chemical contact/splashing during decontamination of equipment; and
- Machinery and mechanical equipment related injuries

It is the objective of this HASP to minimize chemical and physical hazards and operational incidents. The following information is provided to ensure that personnel respond to an emergency situation in a calm, reasonable manner. Prior to commencement of field operations, an emergency medical assistance network will be established. Telephone numbers for the fire department, ambulance, and hospital/medical clinic with an emergency room and locations/routes for the emergency room facility will be available for immediate reference by field staff (Attachment 3). Personnel will be equipped with a cellular phone to assist in summoning assistance, and a vehicle will be available on site at all times to transport injured personnel to the emergency facility if required. The following procedures will be followed:

- The SSC is the lead in all emergency situations;
- A fully stocked first-aid kit will be available on site for immediate assistance;
- An adequate supply of fresh potable water and portable emergency eye wash stations will be available at each work site;
- Site personnel will be trained in emergency procedures during site orientation;
- Evacuation routes from each sampling site will be established by the SSC, and communicated to all field personnel during the Tailgate Safety Meeting before each work shift; and
- The SSC will be responsible for ensuring that all ARA personnel understand site-specific emergency signals and procedures.

6.2 Personnel Injury

General first-aid procedures are included in this section. General first aid procedures include:

- **Skin Contact**—Use copious amounts of soap and water. Rinse the affected area for at least 15 minutes; then provide appropriate medical attention. Eyes should be rinsed for a minimum of 15 minutes upon chemical contamination.
- **Inhalation**—Move to fresh air and, if necessary, decontaminate, and transport to the hospital.

- Ingestion—Transport to the hospital.
- Physical Trauma, Puncture Wound, or Laceration—Stop the bleeding, stabilize, treat for shock, and transport to emergency medical facility.

In the event of an injury, the victim should be stabilized and provided onsite first aid in the "clean zone." If an injury involves a potential trauma to the spinal cord, the victim shall remain where injured, if safely possible, and be moved by trained emergency medical technicians only. Minor injuries such as small lacerations, cuts, and strains shall be initially treated onsite by a first aid qualified member of the field team. Ambulance and hospital support shall be provided for all major injuries, such as head wounds, broken bones, and deep lacerations.

If decontamination is required and does not interfere with essential treatment, the following should be performed:

- Escort victim to the decontamination station;
- Wash, rinse, or cut off protective clothing and equipment;
- Wash exposed body areas with a potable water flush (10 minutes);
- Cover with blanket or (if injury is not serious) dress victim in clean clothing; and
- Transport victim to hospital if necessary or request ambulance support, if needed.

If decontamination is required, but cannot be performed, the following should be completed:

- Wrap the victim in blankets, plastic, or rubber to reduce contamination of other personnel
- Alert emergency and offsite medical personnel to potential contamination; instruct them in specific decontamination procedures, if necessary
- Send along site personnel familiar with the incident.

Should an accident occur, the SSC will complete an accident report and investigate the cause. Accidents must be reported by telephone to project manager as soon as possible, but not later than 2 hours after occurrence and reported in writing within 5 days of occurrence. All other incidents must be reported by telephone, within 8 hours of occurrence, or sooner if conditions permit. Any recommended hazard control must be discussed with the ARA Health and Safety Manager and meet his approval prior to implementation. Any chemical exposure or occupational injuries and illnesses also shall be reported and recorded, if recordable per 29 CFR 1904, on OSHA Form No. 200. Records of all site accidents and first aid treatments will be maintained by the SSC.

First aid and CPR is considered to be a collateral duty, not a primary assignment. In the event an injury occurs and an individual rendering first aid is exposed to blood or other potentially

infectious materials, the person(s) exposed must be provided with follow-up medical surveillance in accordance with 29 CFR 1910.1030(f)(1).

6.3 Telephone/Radio contact Reference List

In many cases, communications will not be readily accessible in the field. In an emergency situation, an individual will be immediately dispatched to contact appropriate emergency response individuals by telephone. If a life threatening injury precludes decontamination of a contaminated individual, the Emergency Response personnel or Fire Department will be contacted immediately by telephone. First aid will be performed if it does not endanger the safety of the individual administering first aid.

Prior to commencement of field operations, an emergency medical assistance network will be established. A vehicle will be available onsite during all activities to transport injured personnel to the identified emergency medical facilities. Additional safety provisions will be made as follows:

- A cellular phone will be available to assist in summoning assistance;
- Telephone numbers of the emergency room facilities and their locations will be posted at the site (including the fastest routes to the emergency facilities);
- The SSC or a designated alternate will be the lead in all emergency situations;
- A first-aid kit will be available at the site;
- An adequate supply of fresh water and portable emergency eyewash will be available at the work site; and
- Evacuation routes from each specific sampling area will be established by the SSC, and communicated to all personnel during the tailgate safety meeting conducted before each work shift.

Attachment 3 provides a list of the emergency/reference numbers to be used during the sampling at the site.

6.4 Changes In Anticipated Conditions

Should unanticipated conditions occur (e.g., encounters with chemical or biological agents, hazardous waste materials, toxic substances), ARA personnel will immediately evacuate the area. A reevaluation of site conditions will be conducted by the SSC. Required changes should be noted on the Field Change Form (Attachment 5) and sent to the EC&HS Officer. Appropriate modifications will be incorporated into the plan before resuming work.

6.5 Accident Reporting

Accidents/Incidents must be reported as soon as possible, but not later than 2 hours after the occurrence and reported in writing within 1 day of occurrence on the form in Attachment 2. All accidents and/or injuries shall be immediately reported to the Site Safety Officer. An accident report and, if necessary, an exposure report will be initiated by the Site Safety Officer and provided

to the Program Safety Officer for processing. An accident reporting form is provided in Attachment 2.

Exposure to a toxic agent may often have delayed or latent effects which can only be detected by specific diagnostic tests. Documenting an exposure may aid in identifying the cause of symptoms or changes in health status indicators (e.g., diagnostic blood tests or pulmonary functions) at a later time. Similarly, physical injuries (e.g., an eye injury caused by dust particles or solvents) may also result in delayed damage to the eye.

The field report will be reviewed and signed by the SSC and forwarded to the ARA EC&HS Officer for review. In addition, the person in charge during the incident will prepare a written report on the actions taken during the incident and follow-up. The reports will be submitted using the Hazardous Waste Site Task/Project Debriefing Questionnaire (Attachment 4) to the ARA EC&HS Officer. The ARA EC&HS Officer will determine the need for further follow-up actions.

6.6 Fire Emergencies

In the event of a fire, attempts will be made to extinguish it with a Class A, B, or C fire extinguisher, if safe to do so. If the fire appears to be growing "out of control," the following steps will be performed:

- The field team should depart the site;
- Verify all present;
- Notify the Fire Department;
- Remove vehicles if safely possible;
- Remove flammable field solvents and fuels if safely possible;
- Await fire-fighting forces; and
- Contact the Project Manager and the ARA Program Safety Officer once the Fire Department is in control of the situation.

7. Hazardous Material Release

In the event a hazardous material release occurs during site activities, attempts may be made to control, divert, absorb, neutralize, or secure the source if direct contact or inhalation hazards are not present. If direct contact or inhalation hazards are present, remedial measures should not be attempted. All hazardous material release incidents shall be reported to the ARA Program Safety Officer as soon as possible.

The following information will be helpful during a notification:

- Chemical/oil name or U.S. Department of Transportation (DOT) I.D. number;
- Cause of release;
- Quantity/concentration of the release;
- Potential for fire;
- Potential for site release evaluation;
- Injuries caused by release; and
- Actions taken.

8. Recordkeeping

Record keeping requirements for health and safety are discussed in Chapter 20 of the ARA Environmental Compliance and Health and Safety Manual. A list of records that should be maintained for this demonstration is provided in Table 8-1.

Table B-6. Record Keeping

Record Kept	Frequency	Documentation
Accident/Incident Reports	As needed	Logbook and separate reports
Inspection of Safety Glasses	Daily	Logbook, if defective
Noise	When hearing protection required	Logbook
Personnel Medical Monitoring	Annual records	Personnel file, copy with worker On site
Temperature/ Weather Conditions	Daily	Logbook
Training of Employees	Annual training records	Personnel file, copy with worker on site

A Supervisor's Accident Investigation Report form is provided as Attachment 3.

9. REFERENCES

The following references were used in writing this plan and may provide more information on site health and safety:

American Conference of Governmental Industrial Hygienists, *2000 TLVs and BEIs, Threshold Limit Values for Chemical Substances and Physical Agents and Biological Exposure Indices*.

29 *CFR* 1910.120, "Hazardous Waste Operations and Emergency Response".

29 *CFR* 1910.1200, "Hazard Communication".

29 *CFR* 1910.1000, "Air Contaminants - Limits for Air Contaminants".

NIOSH Pocket Guide to Chemical Hazards, U.S. Department of Health and Human Services, June 1997.

ARA Environmental Compliance and Health and Safety Manual. Available upon request.

ARA Attachment 2: Supervisor's Accident Investigation Report

Instructions for Parts III and IV are given on the following page. If more space is needed in completing the report, use additional pages. Complete and return this report to the Local EC&HS Official no later than the next working day after the accident.

Part I: General Information

Name of Injured: _____ Division: _____
Location: _____ Employee Number: _____
Date of Accident: _____ Hour: _____ AM/PM Exact Location: _____
Name of Witness: _____ Division: _____

Part II: Description of Accident (*Summarize the accident, providing specific detail.*)

Part III: Causes of Accident (*Determine the cause by analyzing all involved factors, including those listed in the instructions.*)

A. Describe Any **Unsafe** Acts: _____

B. Describe Any **Unsafe** Conditions: _____

ARA Attachment 2: Supervisor's Accident Investigation Report (Continued)

Part IV: Corrective Action Taken (*Summarize actions taken and recommendations made to prevent a similar accident or recurrence of the same accident. Before completing this section, study the steps identified in the instructions.*)

If no actions have been taken, give the reason(s) _____

Signatures: _____
Supervisor Local EC&HS Official

Date Report Prepared: _____

ARA Attachment: Supervisor's Accident Investigation Report Instructions (Continued)

Part III: Accident Causes. *Use the following lists in determining the cause(s) of the accident.*

Selected Unsafe Acts-Personal Factors

Making safety devices inoperable
Failure to use guards provided
Using defective equipment
Servicing equipment in motion
Failure to use proper tools or equipment
Operating machinery or equipment at unsafe speed
Failure to use personal protective equipment
Operating without authority
Lack of skill or knowledge
Unsafe loading or placing

Improper lifting, lowering, or carrying
Taking unsafe position
Unnecessary haste
Influence of alcohol or drugs
Physical limitation or mental attitude
Unaware of hazards
Unsafe act of other

Selected Unsafe Conditions

inadequate guards or protection
Defective tools or equipment
unsafe condition of machine
Congested work area
Poor housekeeping
Unsafe floors, ramps, stairways, platforms
improper material storage
Inadequate warning system
Fire or explosion hazards
hazardous atmosphere: gases, dust, fumes, and vapors
hazardous substances
Inadequate ventilation
Radiation exposures
Excessive noise
Inadequate illumination

ARA Attachment 2: Supervisor's Accident Investigation Report Instructions (Continued)

Part IV: Corrective Action Taken. *Take the following steps to prevent a similar accident or recurrence of the same accident.*

1. Discuss the accident with the employee involved and with any witnesses. Be sure to question the what-where-when-who-how-why aspects of the accident.
2. Inspect the equipment or materials involved for conditions that can be made safer.
3. Study the job setup and manner of doing the work and decide if improvements can be made.
4. Determine if the employee involved is suited for the job he or she is doing, if the employee received adequate training, and if there are any other problems.
5. Develop practical recommendations to correct the problem. Be sure your recommendations will not create other situations that could result in injury to employees.

Documentation and Recordkeeping

Attachment 3 - Emergency Contacts

Emergency Telephone Number Reference List	
Responder	Number
Police Department	911
Fire Department	911
Kaiser Permanente Medical Center 9961 Sierra Ave Fontana, CA 92325	909-427-5269 909-427-7721
Andrea Davis – ARA Project Manager	Office: 850 914-3188 Cell: 850-258-2092
ARA Project Personnel Jeff Rine, Steve Baxley, Andrea Davis, Robert Girvin (SSC), Edward Coppola	ARA office: 850-914-3188 ARA cell: 850-896-5389 Jeff cell: 850-348-2031 Steve cell: 850-596-0211 Andrea cell: 850-832-7538 Robert cell:850-276-5691 Ed cell: 850-319-6986
Chris Diggs – Fontana Water Company Manager	626-786-1737
Andrea Leeson, PhD – ESTCP	703- 696-2118

**ARA Attachment 4: HAZARDOUS WASTE SITE TASK/PROJECT
 DEBRIEFING QUESTIONNAIRE**

The purpose of this questionnaire is to serve as a checklist for documenting a formal review of environmental compliance & health and safety (EC&HS) status upon completion of a field effort at a hazardous waste site. This form is to be prepared by the SSC (or individual designated by the Project Manager) and reviewed by the Project Manager or other cognizant manager within 30 days of the date of last activity at a site.

Site Name: _____

Applicable SSHSP (title, date): _____

Duration of site work covered by this debriefing:

Start Date: _____

Completion Date: _____

4. List ARA Employees who worked at this site:

Name	Employee No.	Name	Employee No.
1.		6.	
2.		7.	
3.		8.	
4.		9.	
5.		10.	

Attach additional list on reverse of this page.

5. List subcontractors to ARA who worked at this site:

Subcontractor Name	Address	Task

6. Were there any accidents or injuries involving ARA or subcontractor personnel that required medical treatment? Yes/No _

If yes, give names of individual(s), date(s) or injury, and attach a copy of the supervisor's accident investigation report:

Name	Date	Employer
1.		
2.		
3.		

7. Did the subcontractors comply with applicable health and safety requirements?

Yes/No

If no, give details: _____

8. Were there any unplanned releases of contaminated material to the environment (spills to navigable water, non compliant discharges to a POTW)? Yes/No

If yes, what notifications were made (e.g. National Response Center, client, EPA, or State Agency)? Attach relevant correspondence.

9. Were employee exposures to chemical hazards monitored? Yes/No

If yes, complete the following:

A. Monitoring using OVA or Hnu Instrument:

Action level stated in the SSHSP: ____

Was action level ever exceeded: Yes/No

If yes, indicate date(s) and action taken.

Date	Action

B. Monitoring using chemical-specific devices (such as Draeger tubes, H₂S monitor, samples collected for laboratory analysis):

Substance Measured	PEL	BZ or Area	Lowest Measured Exposure	Highest Measured Exposure	Respiratory Protection Used (Yes/No)
1.					
2.					
3.					
4.					
5.					

Comments: _____

10. A. Were employee exposures to noise measured at this site? Yes / No

If yes, attach applicable reports.

B. List significant sources of noise (indicate type of drill rig, compressors, pumps, and other noise generating equipment)

1. _____
2. _____
3. _____
4. _____

C. Was hearing protection required? Yes / No

If hearing protection was required, was it provided? Yes / No

D. Was the use of hearing protection in high noise areas enforced? Yes / No

11. Were radiation hazards monitored at the site? Yes / No

If yes, complete the following:

Types of radiation: ___ alpha ___ beta ___ gamma

Isotopes: __

Airborne radioactive contamination _____

Non-Airborne radioactivity (fixed contamination, sealed sources, etc.) _____

Cumulative radiation doses for site workers by job category (i.e., rig geologist, supervisor, field technician, visitors, subcontractors, other)

Job Category	Cumulative Dose (millirem)	Number of Employees Per Category

12. Were any unusual conditions encountered at this site? Yes / No

If yes, please explain: _____

13. Describe any lessons learned at this site, regarding hazard identification and control that should be communicated to other ARA personnel working at hazardous waste _____

Prepared By: _____ **Date:** _____

Reviewed By: _____ **Date:** _____

ARA Attachment 5: Field Change Request

ARA	FIELD CHANGE REQUEST
Field Charge No: _____	Page of ___ of ___
Project Number: _____	
Project Name: _____	
Change Request	
Applicable Reference: _____	
Description of Change: _____	

Reason for Change: _____	

Impact on Present and Completed Work: _____	

Requested by: _____	Date: _____
(ARA Field Geologist/Engineer)	
Acknowledged by: _____	Date: _____
(Subcontractor Representative/Company Name)	
Field Operations Manager Recommendation	
Recommended Disposition: _____	

Recommended by: _____	Date: _____
(ARA Field Operations Manager)	
Health and Safety Review	
Approved/Disapproved by: _____	Date: _____
(ARA Qualified Individual)	
Project Manager Review	
Final Disposition: _____	

Approved/Disapproved by: _____	Date: _____
(ARA Project Manager)	