



CERAL 3450

“Chrome-Free” Aluminum Ceramic Coating



Bruce Bodger
DemVal, Inc.
New York • Oklahoma City
202-521-4060 • 405-213-1940



under contract FA8601-04-F-0040 - subcontract USAF-0040-SC-0014-11

SERDP/ESTCP WORKSHOP · ISSUES FOR SUSTAINING AIRCRAFT
FEB 27, 2008 · TEMPE, ARIZONA

Report Documentation Page

Form Approved
OMB No. 0704-0188

Public reporting burden for the collection of information is estimated to average 1 hour per response, including the time for reviewing instructions, searching existing data sources, gathering and maintaining the data needed, and completing and reviewing the collection of information. Send comments regarding this burden estimate or any other aspect of this collection of information, including suggestions for reducing this burden, to Washington Headquarters Services, Directorate for Information Operations and Reports, 1215 Jefferson Davis Highway, Suite 1204, Arlington VA 22202-4302. Respondents should be aware that notwithstanding any other provision of law, no person shall be subject to a penalty for failing to comply with a collection of information if it does not display a currently valid OMB control number.

1. REPORT DATE 27 FEB 2008	2. REPORT TYPE	3. DATES COVERED 00-00-2008 to 00-00-2008	
4. TITLE AND SUBTITLE CERAL 3450 'Chrome-Free' Aluminum Ceramic Coating		5a. CONTRACT NUMBER	
		5b. GRANT NUMBER	
		5c. PROGRAM ELEMENT NUMBER	
6. AUTHOR(S)		5d. PROJECT NUMBER	
		5e. TASK NUMBER	
		5f. WORK UNIT NUMBER	
7. PERFORMING ORGANIZATION NAME(S) AND ADDRESS(ES) DemVal Inc,17 Richard Place Suite 2475,Ronkonkoma,NY,11779		8. PERFORMING ORGANIZATION REPORT NUMBER	
9. SPONSORING/MONITORING AGENCY NAME(S) AND ADDRESS(ES)		10. SPONSOR/MONITOR'S ACRONYM(S)	
		11. SPONSOR/MONITOR'S REPORT NUMBER(S)	
12. DISTRIBUTION/AVAILABILITY STATEMENT Approved for public release; distribution unlimited			
13. SUPPLEMENTARY NOTES Surface Finishing and Repair Issues for Sustaining New Military Aircraft Workshop, February 26-28, 2008, Tempe, AZ. Sponsored by SERDP/ESTCP.			
14. ABSTRACT			
15. SUBJECT TERMS			
16. SECURITY CLASSIFICATION OF:			17. LIMITATION OF ABSTRACT Same as Report (SAR)
a. REPORT unclassified	b. ABSTRACT unclassified	c. THIS PAGE unclassified	
			18. NUMBER OF PAGES 34
			19a. NAME OF RESPONSIBLE PERSON

Introduction

- DemVal, Inc.
 - Bruce Bodger, President / Managing Director
 - Engineering Consulting to the DoD and others
 - Environmental Compliance with focus on coatings
 - Consulting / Market Penetration
- Gebr. M. und M. Morant, GmbH
 - Max Morant, President
 - Grassau, Germany (Munich)
 - 50 Year History
 - Industrial Detergents, Decontamination Agents
 - Other products requiring advanced chemistry; cleaners, coatings, paints.



Outline

- Introduction
- The Problems
- Alternative Solutions Analysis (PAR)
- Down Selection
- Discussion of Down Selected Product
- Implementation Strategy
- Test Assets
- Conclusions



Introduction

- The traditional gas turbine engine compressor is constructed primarily of a variety of low alloy and stainless steels.
- Typical environmental conditions
 - Temperatures up to 1100°F (600°C)
 - Corrosion
 - Heat cycling
 - Erosion
- Led to the development of coatings to help sustain the substrate: fouling and corrosion resistance, optimum airflow efficiencies, and an ultra-smooth sealed finish.



Introduction

- Early coatings were replaced by low temperature pack aluminides, diffused nickel-cadmium plating, and eventually by aluminum ceramic coatings
- These aluminum ceramic coatings are applied by standard spraying techniques followed by drying and curing of the coating.
- Aluminum-ceramic coatings of the SermeTel W® family widely accepted as “industry standard”.



The Problems

- Contains unsafe levels of chromic acid.
- When in liquid (sprayable) state, and prior to baking, produces an unsafe environment for the worker:

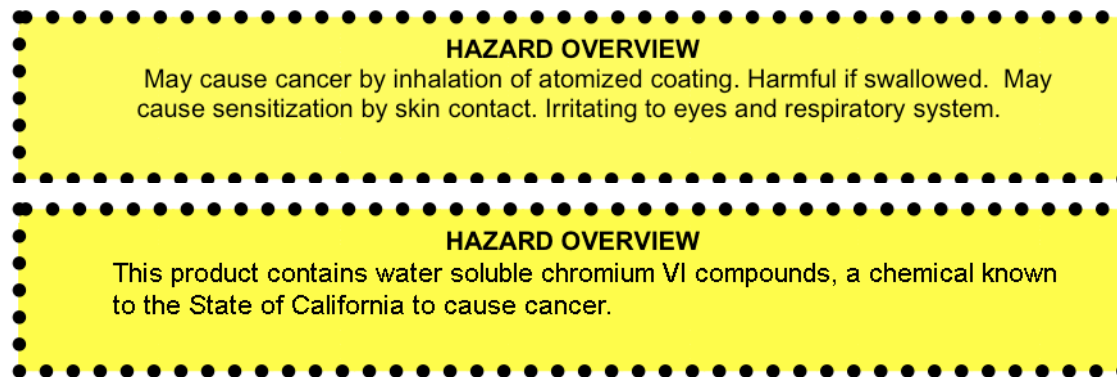

- Proprietary, sole source
- Marketing model discourages organic capability.



Potential Alternatives

- December 11, 2002, Concurrent Technologies, Contract GS-23F-0061L, funded by PEWG
- ...to provide a technical analysis of identified alternatives to current aluminum-ceramic coatings based on preliminary screening criteria provided by project stakeholders.
 - P&W, GEAE, OC-ALC, NADEP JAX, NADEP CP



Potential Alternatives

- January 6, 2006, DemVal Contract FA8601-04-F-0040, funded by PEWG
 - Expanded to include airframe considerations, JSF
 - To include commercial (practical) considerations
 - “The goal of the overall project is not only to provide a listing of environmentally compliant coatings but also to insure that they are commercially viable. Issues such as licensing restrictions, cost, availability, and the manufacturers business model (whether or not the coatings may be applied at the depot level) must all be taken into account.”



Down Selected Product

- Peeked our curiosity:
 - “In terms of drop-in coatings listed in Table 9, Ceral products were noted as already qualified for use as alternatives to SermeTel W, and therefore were dropped from further consideration.”
- Decision to investigate Ceral products further (of course)



Ceral 3450

- Approved by:
 - GE (Power)
 - Rolls Royce, PLC.
 - Snecma
 - **Standard Aero**
 - Siemens
 - Pratt Canada
 - Other EU and NATO suppliers

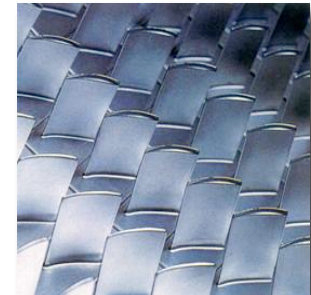
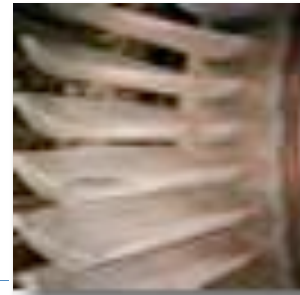

Chemical Analysis

	Analysis	RoHS Limit	Disposition
Sermetel W Liquid (Cr-total)	17,900 mg/kg (1.79 wt%)	-----	-----
Sermetel W Liquid (Cr-VI)	12,200 mg/kg (1.22 wt%)	1,000 ppm (mg/kg)	Over Limit
Ceral 34 Liquid (Cr-total)	23,800 mg/kg (2.38 wt%)	-----	-----
Ceral 34 Liquid (Cr-VI)	<125 mg/kg (<0.0125 wt%)	1,000 ppm (mg/kg)	Conforms
Ceral 34 Coating (Cr-total)	6,640 mg/kg (0.664 wt%)	-----	-----
Ceral 34 Coating (Cr-VI)	<10 mg/kg (<0.000010 wt%)	1,000 ppm (mg/kg)	Conforms



Down Selected Product

- **PWA**

CERAL 114 specified in PWA 595
CERAL 350/1 specified in PWA 561
CERAL VPW S-1 specified in PWA 36054
→ CERAL products can be used per PWA 830 and PWA 110
CERAL 34 specified in CPW 731

- **GE**

CERAL 114 specified in DFO-A50TF1
CERAL 350/1 specified in DFO-A50TF196
→ CERAL products can be used per A50TF1, F50TF1, F50TF34, A50TF196.
CERAL 3450 sc specified in P 16A – AG 5
CERAL 10 specified in P 16C – AG 14

- **RR**

CERAL 114 specified in MLC 104
CERAL 350/1 specified in MLC 104
→ CERAL products can be used per MSRR 9140 and RPS 666.
CERAL 3450sc has to be approved by the coating supplier according to the RPS
CERAL 10 is currently be tested by RR for an approval.

- **SNECMA**

CERAL 114 specified in DMP 16-025
CERAL 350/1 specified in DMP 16-025

- **Standard Aero**

CERAL 34 approved REPORT No. 29-98, Aug. 1998

- **MTU**

CERAL 114 specified in MTS 1008
CERAL 350/1 specified in MTS 1028
CERAL VPW S-1 specified in MTS 1009
CERAL 10 specified in MTS 1397
→ CERAL products can be used per MTV's 330, 344, 345, 371, 375, 578, 594.

- **ABB**

CERAL 10 cited in the drawings.

- **SIEMENS/KWU**

CERAL 3450sc specified in TLV 8904 39/00, Febr. 2000
CERAL 3450sc specified in TLV 89043901

- **ANSALDO ENERGIA**

CERAL 3450 sc specified in WTL 890439

- **TURBOUNION**

CERAL 114 specified in CPP 4M21
→ CERAL products can be used per TU 291 on RB 199 and EJ 200 engines.

- **IAE**

CERAL 114 approved via cross reference list in the IAE overhaul handbook
→ CERAL products can be used for the V2500 engine.

- **ALSTOM Power**

CERAL 10 specified in APMS000080

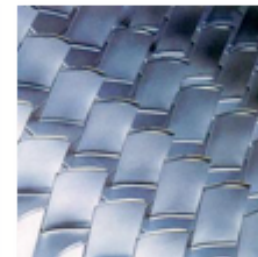
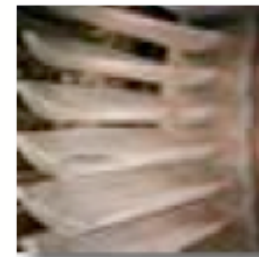

Standard Aero

- AeroBlue DP[®] was designed as a substitute for SermeTel 5380 DP[®] Coating System
- AeroBlue DP[®] was developed to allow coating application in house to eliminate shipping and reduce TAT (target 5 day average reduction)
- The base coat is aluminum particles in an inorganic binder (Ceral 34)
- The proprietary top coat seals the bond coat and improves the surface finish



Standard Aero Methodology

Airworthiness Standard FAR 33 and Amendments 1 to 5		Compliance			Approval	
Paragraph	Requirement	Means	Documents	Summary/Methods	Delegated	Signoff
FAR 33.15	Materials	Analysis and tests	SAL Report	Microstructure – Visual Examination Composition - SEM Adhesion, Tensile – ASTM C633 Adhesion, Bend – PWA 595 Electrical Resistance – MIL-C-81751B Impact Resistance, Falling Weight, MIL-C-81751B	SAL DE 04	
FAR 33.19	Durability	Analysis and tests	SAL Report	Erosion Resistance - ASTM D 968 Method B Corrosion Resistance - Salt Spray, ASTM B117 and PWA595 Hot Oil Resistance – MIL-C-81751B and PWA595 Fuel Resistance – PWA 595 Hot Water Resistance – Hot Soak, PWA 595 Thermal Shock Resistance – Immersion, MIL-C-81751B Heat Resistance – PWA 595 Modified Accelerated Corrosion (CASS) – ASTM B368 Spall Resistance – ASTM-C-703, Antimony Trichloride Method	SAL DE 04	
FAR 33.63	Vibration	Analysis and tests	SAL Report	Analysis based on Coating Thickness and Weight.	SAL DE 04	
FAR 33.65	Surge & Stall Characteristic	Analysis	SAL Report	Surface Profile – Scribe Profilometer (ANSI B 46.1	SAL DE 04	



Standard Aero Service Experience

What works here....



...or here...



...may not work HERE!



Standard Aero Service Experience

Pratt & Whitney Canada PT6

- Applied to over 3200 engines since 1998
- Approximately 8.2 Million flight hours to June 2007
- The coating performed as expected and provided good corrosion protection
- No service difficulties or warranties related to the coating

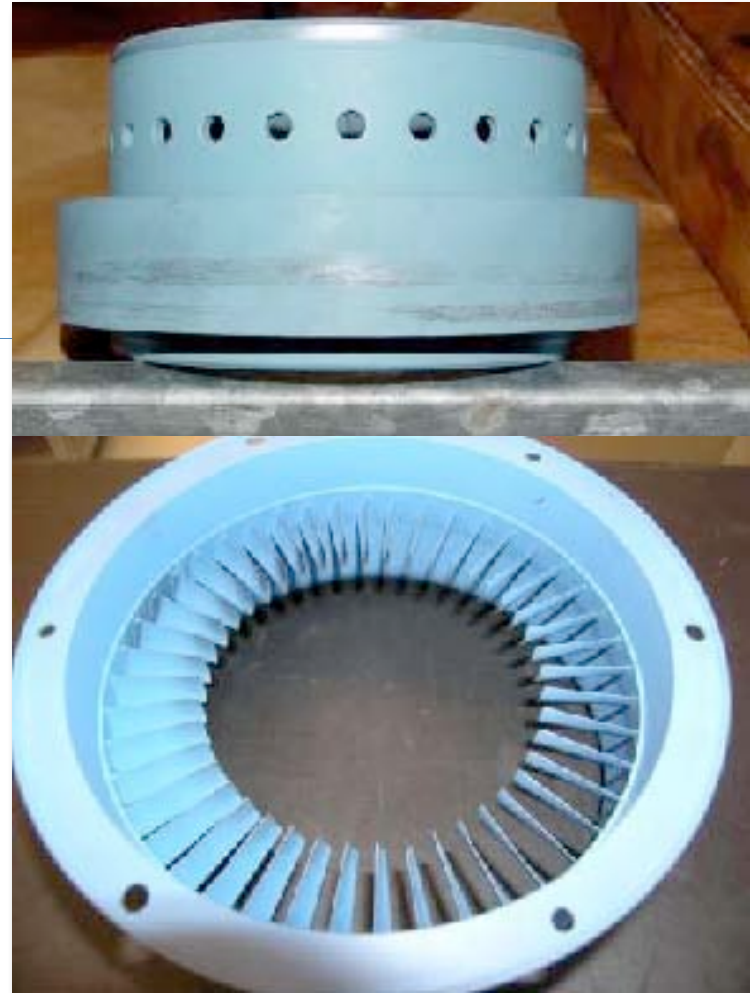

Standard Aero Service Experience

Rolls Royce T56

- Powers the Lockheed C-130 & L100 Hercules, P-3 Orion; Grumman E-2 Hawkeye
- A controlled service evaluation was conducted in a high erosion environment
- Provided good protection on about 146 engines with about 0.35 million flight hours to June 2007



Standard Aero Service Experience

Rolls Royce 501 Industrial

- Industrial version of T56
- Inlet air filters typically reduce dust ingestion, but the operating environments can be very corrosive



- Borescope photo at ~25,000 hours in a paper mill shows the coating is in excellent condition
- Applied on about 440 compressors with 2.6 million hours of service



Implementation Strategy

- FOREIGN COMPARATIVE TESTING (FCT) PROGRAM
 - Mission: To test items and technologies of our foreign allies and friends that have a high Technology Readiness Level (TRL) in order to satisfy valid defense requirements more quickly and economically.



Implementation Strategy

- Congressionally authorized program
- Consistent with DoD acquisition guidance
- Objectives: To improve the U.S. warfighter's capabilities and reduce expenditures through:
 - Rapidly fielding quality military equipment
 - Eliminating unnecessary duplication of research, development, test, and evaluation
 - Reducing life cycle or procurement costs
 - Enhancing standardization and interoperability
 - Promoting competition by qualifying alternative sources
 - Improving the U.S. military industrial base



Implementation Strategy

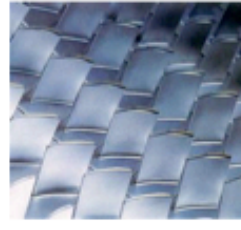
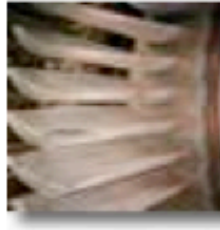

Gebr.M. und M.
Morant GmbH
Grassau, Germany

Description: Aluminum-Ceramic Coatings are used extensively throughout DoD as a means to provide protection from erosion and corrosion on turbine engines, landing gear, and other surfaces of strategic components that are exposed to severe environments. Materials currently in use contain carcinogenic chrome. CERAL 3450 is a LOW CHROME drop-in replacement that lasts up to twice as long, costs less, and increases engine performance by reducing friction and wear. The coating is presently produced in Germany and has gained wide acceptance for use in European, NATO, and Canadian military applications.

Warfighter Impact: Increased engine efficiency. Fuel savings. Increased Time Between Overhauls

Success: Less corrosion / erosion related repairs; reduced downtime for air & ground powered vehicles.

Participants

Sponsoring Service: USAF

Sponsoring Program Office: OC-ALC/LR & 76th PMXG/CC

Company, Country/State: Gebr.M. und M. Morant GmbH, Germany in partnership with DemVal, Inc. USA

Schedule

Test/Plan	1Q07
Functional Testing	2Q07
Engine Testing	3Q07
Test Review	1Q08
Procurement	2Q08

Funding:

FCT, TF33-CIP

RDT&E Cost Savings	\$1.5M to \$5M
O&S Cost Savings	\$10M
Procurement Cost Savings	-\$1M/year
Procurement Potential	>\$1.5M/year
Implementation Plan / Other Benefits: Joint Test Protocol, drop-in replacement, process specification modification, TRL 9, no CPP.	



Implementation Strategy

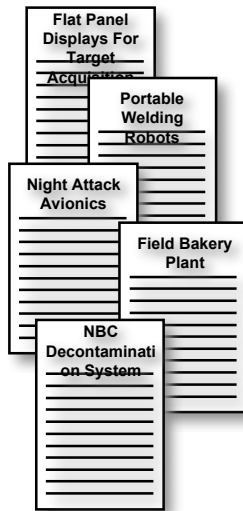

**SUMMARY
PROPOSALS TO
OSD**

**DRAFT
PROPOSALS TO
OSD**

**FINAL
PROPOSALS TO
OSD**

**OSD REVIEW
COMMITTEE**

**PROJECTS APPROVED
AND FUNDED**



JAN



APR



1 JUN



JUN-JUL



OCT / NOV



Implementation Strategy

Task

- 1) Site Visits, TWG's, Reports
- 2) Project & Test Planning
- 3) Fabricate Test Coupons
- 4) Perform Functional Tests
- 5) Support AMT Requirements
- 6) Final T&E Report
- 7) Final Disposition Report
- 8) Manufacture in USA
- 9) Availability to DoD

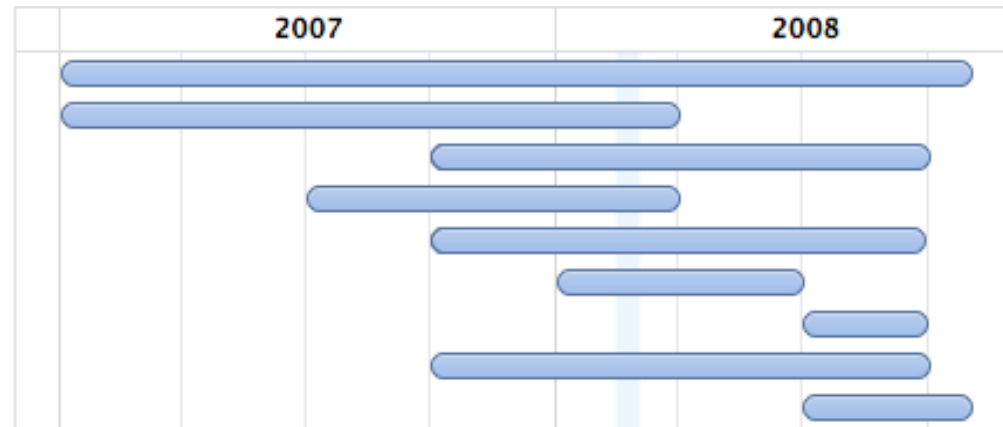

- FedBizOpps posting April 25, 2006 - Solicitation FA8104-06-N-0001
- Approved by FCT October 2006, two-year project
- Contract FA8601-04-F-0040 Subcontract USAF-0040-SC-0014-11



Ceral 3450 at Chromalloy OK

- Worked with Chromalloy Oklahoma who is now approved to apply Ceral 3450.
- Their interests
 - “Current permissible exposure limits for hexavalent chrome potentially limits production (based on time weighted average exposure)”
 - Products such as Ceral 3450 which significantly reduce that exposure will mitigate this effect.”
 - Commercial interests
 - Licensing, cost, shelf-life, training



AMT Test Assets

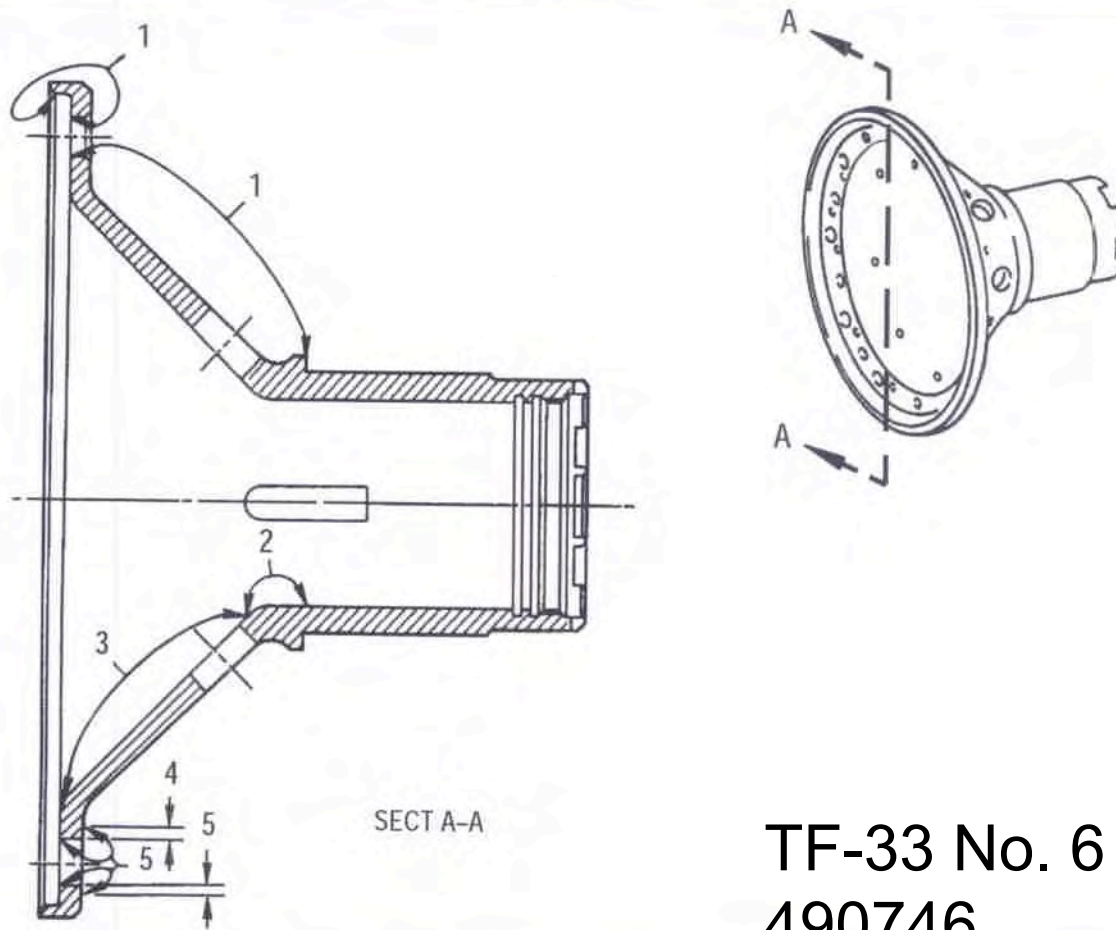

TF-33 No. 6 Hub, P/N
490746



AMT Test Assets

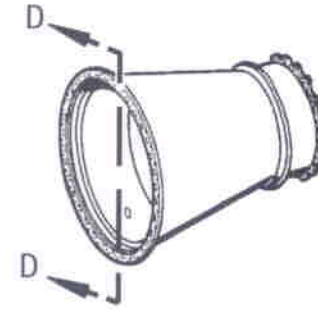
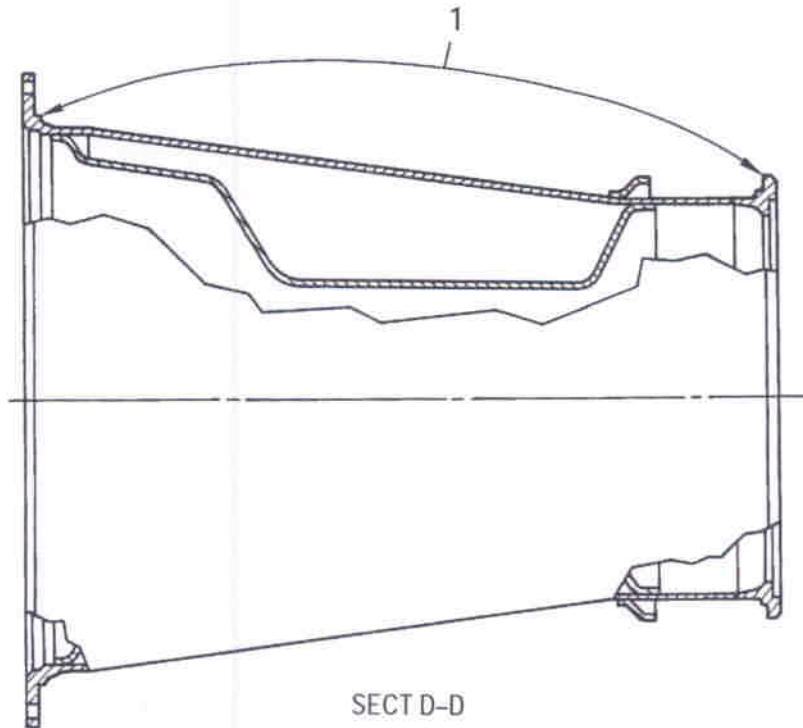

TF-33 Heat Shield / Turbine
Front Bearing Support, P/N
800216



AMT Test Assets



TF-33 Outer Compressor 1st Stage Duct, P/N 794814



AMT Test Assets

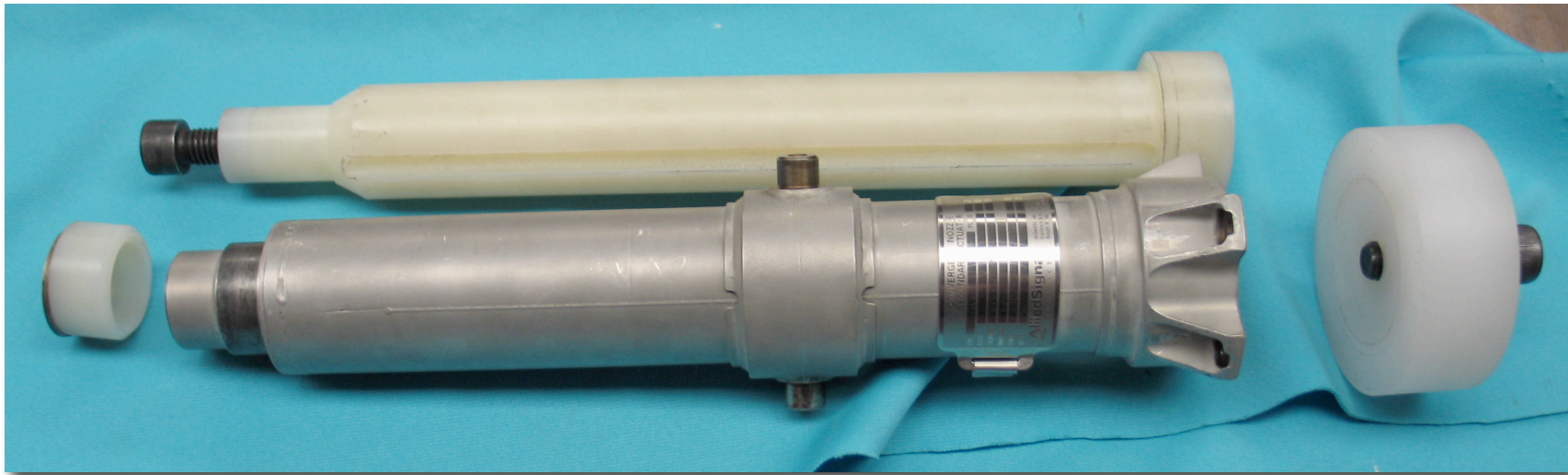

F-100 Afterburner Actuator Outer Housing, P/N 2663473



AMT Test Assets



F-100 Low Pressure Turbine Shaft, P/N 4047579



AMT Test Assets - Status

Part No.	Nomenclature	TMS	AMT Status	Date Installed	Hours
490746	#6 Hub	TF33	Awaiting Test Cell run @ Tinker	July 07	101 EFH*
800216	Heat Shield	TF33	Awaiting Test Cell run @ Tinker	July 07	101 EFH*
794814	Fan Duct	TF33	Awaiting Installation @ Tinker	N/A	N/A
2663473	Actuators (2)	F100	Awaiting AMT Installation @ PWA San Antonio	N/A	N/A
4047579	Turbine Shaft	F100	Awaiting AMT Installation @ PWA San Antonio	N/A	N/A



Conclusions

Standard Aero:

- “The goal to reduce coating TAT by 5 days on average by elimination of subcontract and shipping was achieved.”
- “..has millions of hours of successful service in flight, marine and industrial applications.”

Chromalloy Oklahoma:

- “From the standpoint of the operator, application of Ceral 3450 was completely identical – a change of coating materials from Aseal 518/598 or from Sermetel W/Sermaseal 570A to Ceral 3450 would not be noticed”
- “Exposure to hexavalent chrome would be significantly reduced by using Ceral 3450 as compared to Aseal 518/598 or Sermetel W/Sermaseal 570A”



Conclusions

Commissioned Report:

- “Ceral 34 basecoat when used in conjunction with Ceral 50 seal coat has properties that conform to all of the relevant Pratt & Whitney specifications and that render it an equivalent coating to SermeTel 5380 DP”.
- “These properties make the coating one that is considered superior to SermeTel W”.
- In its liquid state the Sermetel W base coat contains 97.6 times as much hexavalent chrome (Chrome-VI) as the Ceral 34 base coat (12,200 ppm vs. <125 ppm). The cured Ceral 34 base coat contains <10 ppm, which, under US Government regulations, qualifies it as “Chrome Free”.



Acknowledgments

OC-ALC Tinker AFB, Oklahoma City, OK

- Mr. John Over, SES, Director of Propulsion
- Brig. General Judith Fedder, Commander, 76th MXW
- Col. Brian Tri, 76th PMXG/CC
- Mr. Aaron Larson, Senior Propulsion System Engineer
- Mr. Bill Coppedge - Director, Process Control and Improvement
- Mr. James (Mickey) Conklin - PEWG Program Executive
- Mr. Tyrone Giles - Cognizant Engineer - F100 Engine
- Mr. Matt Pantoja - Cognizant Engineer - TF33 Engine
- Mr. Rob Stebbin - Material & Process Engineer

Commercial

- Mr. Bob Bondaruk - GDIT - PEWG Program Manager
- Mr. Rick Craddock, Mr. Ron Ainsworth - GDIT Logistics
- Mr. Wayne Thomas - Chief Engineer, Standard Aero Ltd.
- Mr. Cliff Fagan - Engineering Manager, Chromalloy Oklahoma



Environmental Compliant Alternative

THANK YOU VERY MUCH

Bruce Bodger
DemVal, Inc.
17 Richard Place
Ronkonkoma, NY 11779
631-835-8400 info@demval.com

