

# Program Managers Tool Kit



Sixteenth Edition (Ver. 1.0)  
January 2011  
Author: William Parker

# Report Documentation Page

Form Approved  
OMB No. 0704-0188

Public reporting burden for the collection of information is estimated to average 1 hour per response, including the time for reviewing instructions, searching existing data sources, gathering and maintaining the data needed, and completing and reviewing the collection of information. Send comments regarding this burden estimate or any other aspect of this collection of information, including suggestions for reducing this burden, to Washington Headquarters Services, Directorate for Information Operations and Reports, 1215 Jefferson Davis Highway, Suite 1204, Arlington VA 22202-4302. Respondents should be aware that notwithstanding any other provision of law, no person shall be subject to a penalty for failing to comply with a collection of information if it does not display a currently valid OMB control number.

1. REPORT DATE <b>JAN 2011</b>		2. REPORT TYPE		3. DATES COVERED <b>00-00-2011 to 00-00-2011</b>	
4. TITLE AND SUBTITLE <b>Defense Acquisition University Program Managers Tool Kit</b>				5a. CONTRACT NUMBER	
				5b. GRANT NUMBER	
				5c. PROGRAM ELEMENT NUMBER	
6. AUTHOR(S)				5d. PROJECT NUMBER	
				5e. TASK NUMBER	
				5f. WORK UNIT NUMBER	
7. PERFORMING ORGANIZATION NAME(S) AND ADDRESS(ES) <b>Defense Acquisition University, Fort Belvoir, VA, 22060</b>				8. PERFORMING ORGANIZATION REPORT NUMBER	
9. SPONSORING/MONITORING AGENCY NAME(S) AND ADDRESS(ES)				10. SPONSOR/MONITOR'S ACRONYM(S)	
				11. SPONSOR/MONITOR'S REPORT NUMBER(S)	
12. DISTRIBUTION/AVAILABILITY STATEMENT <b>Approved for public release; distribution unlimited</b>					
13. SUPPLEMENTARY NOTES					
14. ABSTRACT					
15. SUBJECT TERMS					
16. SECURITY CLASSIFICATION OF:			17. LIMITATION OF ABSTRACT	18. NUMBER OF PAGES	19a. NAME OF RESPONSIBLE PERSON
a. REPORT <b>unclassified</b>	b. ABSTRACT <b>unclassified</b>	c. THIS PAGE <b>unclassified</b>			

# DAU PROGRAM MANAGERS TOOL KIT

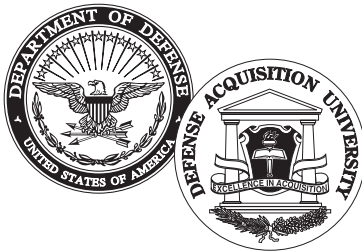

Sixteenth Edition (Ver. 1.0)

January 2011

# DAU PROGRAM MANAGERS TOOL KIT

---

For sale by the  
U.S. Superintendent of Documents, Government Printing Office  
Internet: <http://bookstore.gpo.gov/> Phone: 202-512-1800 Fax: 202-512-2250  
Mail Stop: SSOP, Washington, DC 20402-0001  
ISBN 978-0-16-087469-7, Stock Number 008-020-01604-7

## PREFACE

This Sixteenth Edition (version 1.0) of the *DAU Program Managers Tool Kit* contains a graphic summary of acquisition policies and managerial skills frequently required by DoD program managers. It is a current version of a “Tool Box” that was first developed by Charles F. Schied of the Defense Acquisition University (DAU) Program Management Course (PMC) 92-1. The information in the *Tool Kit* is extracted from DAU course material and is based on DoDD 5000.01 (May 12, 2003), DoDI 5000.02 (December 8, 2008), the *Defense Acquisition Guidebook* (DAG), (August 5, 2010), CJCSI 6212.01E (December 15, 2008), CJCSI 3170.01G (March 1, 2009), the *Joint Capabilities Integration and Development System Manual* (July 31, 2009), and the *Weapon Systems Acquisition Reform Act of 2009*. Material from the DAU Acker Library and Knowledge Repository was also used.

Since the *DAU Program Managers Tool Kit* is a compilation of classroom presentation and teaching materials used in a number of different courses at DAU, the charts and tables vary in look and feel.

Users of the *Tool Kit* are reminded that this summary is a guide only and should not be used as a substitute for official policy guidance. Periodic review of official policy guidance is recommended.

An e-Toolkit has been developed which contains current updated acquisition guidance and direction (<https://pmtoolkit.dau.mil>). This (“hard-copy”) *Tool Kit* is current as of January 1, 2011 and is extracted from the e-Tool Kit. The hard copy *Tool Kit* can be found at <http://www.dau.mil/pubscats/pages/tool%20kit.aspx>.



## ACKNOWLEDGMENTS

As sponsor of the *Tool Kit*, the Learning Capabilities Integration Center (LCIC) recognizes the following members of the DAU staff and faculty for their input to this Sixteenth Edition (Version 1.0):

- Bill Bahnmaier, formerly of DAU's Program Management and Leadership Department, Capital and Northeast Region, for coordinating the input and editing the material received.
- Chuck Cochran, formerly the DAU Program Management Center Director and currently a DoD contractor supporting DAU, for his significant contributions regarding current DoD acquisition policy.
- Mike Dorohovich, CSC Corporation contractor supporting DAU, for his contribution regarding the DAU knowledge sharing systems.
- Andrea Reese, CSC Corporation contractor supporting DAU, for her efforts in developing and updating the e-Tool Kit.
- The Defense Systems Management College – School of Program Managers (DSMC-SPM) for input, including Duane Tripp, international acquisition policy and guidance; Al Moseley, Diamond Card and Probability of Program Success Model; and Roberta Tomasini and John Krieger, budgeting and finance issues.
- The Learning Capabilities Integration Center and its Center Directors and Performance Learning Directors, including Sharon Jackson, Robert Pratt, Leslie Deneault, Bill Kobren, John Claxton, John Snoderly, George Prosnik, Bill Motley, and Larry Baker.
- Marty Sherman, DAU West Region, for his contribution regarding the Continuous Process Improvement/Lean Six Sigma processes.
- The Visual Arts and Press Department, including Miracle Riese for layout/graphics, Debbie Gonzalez for editing, and Frances Battle for serving as liaison with the printers.

Other significant contributors from the DAU faculty were John Kelley of the Program Management Department; Robert Carlson, Kim Hunter, Bob Gustavus, Gerry Land, and Miriam Cohe of the Business, Cost Estimating, and Financial Management Department; Tom Simcik of the Logistics Management Department; and Randy Zittel of the Engineering and Technology Department. Dr. Paul Alfieri, professor for T&E also provided valuable information on test and evaluation processes.



Tim Shannon  
 Director, Learning Capabilities  
 Integration Center



William Parker  
 Director, Center for  
 Acquisition Management



## TABLE OF CONTENTS

Preface .....	iii
Acknowledgments .....	v
<b>CHAPTER 1—ACQUISITION PROCESS AND RESOURCES .....</b>	<b>1</b>
The Program Manager’s Bill of Rights and Responsibilities .....	2
Defense Acquisition Management System .....	3
Acquisition Categories (ACAT) .....	4
Acquisition Strategy Considerations.....	5
Acquisition, Technology and Logistics (AT&L) Knowledge	
Management System .....	6–8
Defense Acquisition Portal (DAP) .....	6
Ask A Professor (AAP) .....	6
Acquisition Community Connection (ACC) .....	6
Defense Acquisition Guidebook (DAG) .....	7
ACQuipedia .....	7
Integrated Defense AT&L Life Cycle Management System Chart .....	7–8
AT&LACquire .....	8
Best Practices Clearinghouse (BPCh) .....	8
Performance Learning Tools .....	8
Defense Acquisition Board Timeline Milestones B, C, and FRPDR .....	9
Milestone Decision Information—A Possible Construct .....	9
Requirements for Milestone/Decision Reviews.....	10–11
Interoperability Certification .....	12
S&T Linkage to Defense Acquisition Process .....	13
Joint Capabilities Technology Demonstration (JCTD).....	14
Acquisition Program vs. ATD and JCTD .....	15
Program Structure .....	16
<b>INTERNATIONAL ACQUISITION .....</b>	<b>17–18</b>
DoD International Armaments Cooperation Policy .....	17
The Scope of Defense Cooperation.....	17
Defense Sales vs. Cooperative Acquisition.....	18
International Activities Associated with Defense Acquisition Phases .....	18
<b>FUNDS MANAGEMENT .....</b>	<b>19–33</b>
Resource Allocation Process—Overlap .....	19
PPBE—Planning Phase .....	20
PPBE—Program/Budget Review .....	20
Resource Allocation Process.....	21
Congressional Enactment Timetable .....	22
Procurement Appropriations (Account Numbers and Budget Activities) .....	23–24
Research, Dev., Test, and Eval. (RDT&E) Appropriations (Account Numbers).....	25
RDT&E Appropriations (Relationship Between MFP 6 R&D	
Categories and RDT&E Appropriations Budget Activities) .....	25

**CHAPTER 1—ACQUISITION MANAGEMENT (CONTINUED)**

Sample Navy Appropriations and Budget Activities .....	26
Appropriation Life.....	27
Below Threshold Reprogramming Actions .....	27
Life Cycle Cost Composition .....	28
Product Improvements .....	28
Cost Estimating.....	29
Cost Estimating Relationships (CER)—Parametric .....	29
Cost Estimating Requirements.....	30
Program Cost and Schedule Breach Parameters.....	31
Earned Value Management “Gold Card”.....	32–33
<b>CONTRACTING .....</b>	<b>34–38</b>
Contracting—Components of Contract Price .....	34
Types of Contracts .....	34
Contract Type Features .....	35–36
Pre-Solicitation Process .....	37
Post-Solicitation Process.....	37
Other Ways to Buy.....	38
<b>DEFENSE INDUSTRY BUSINESS MANAGEMENT .....</b>	<b>39–45</b>
Contractor Profitability Ratios.....	39
Aerospace/Defense Industry Contractor Profitability Ratios.....	40
Lockheed Martin Corp.—Dupont Formula Analysis (An Example).....	41
Cash Cycle.....	42
Contractor Financing and Payments.....	42
Direct and Indirect Costs .....	43
Assigning Indirect Costs .....	43
Life Cycle of Indirect Cost Rates .....	44
Contractor’s Cost Proposal .....	44
Contractor Business Planning Process Outputs.....	45
<b>LOGISTICS .....</b>	<b>46–54</b>
Life Cycle Logistics .....	46
Principal Life Cycle Logistics Goals/Objectives .....	46
Goal 1: Life Cycle Sustainment Metrics .....	46–47
Goal 2: Affordable System Operational Effectiveness (SOE) .....	48
Goal 3: DoD Product Support Strategy Process Model .....	48–49
Goal 4: Integrated Product Support Elements .....	49–50
Goal 5: Product Support Business Model (PSBM) .....	51
The Sustainment Chart.....	52
Logistics Management Community of Practice (LOG CoP) .....	52
Life Cycle Logistics Linkage to Defense Acquisition Process.....	53
<i>Defense Acquisition Guidebook</i> —Life Cycle Logistics .....	54
Life Cycle Logistics References and Guidance .....	54

**CHAPTER 1—ACQUISITION MANAGEMENT (CONTINUED)**

<b>ORGANIZATION</b> .....	55–56
Program Office Organization Structures (Examples) .....	55–56
“Traditional” or Functional Structure .....	55
“Pure” Product Structure .....	55
Matrix Structure.....	56
Integrated Product Teams.....	56
<b>MANUFACTURING</b> .....	57–61
The Role of Manufacturing in the Acquisition Process .....	57
Common Production Risks That Greatly Impact Cost, Schedule, and Performance .....	57
Producibility.....	58–61
Producibility ( <i>Defense Acquisition Guidebook</i> ) .....	58
Quality Management Systems ( <i>Defense Acquisition Guidebook</i> ) .....	59
Key Characteristics and Variation Reduction .....	59–60
Production Readiness Review (PRR).....	61
Additional Manufacturing Information Sources .....	61
<b>TEST AND EVALUATION</b> .....	62–67
Test and Evaluation (T&E)—Types and Tasks .....	62
Test and Evaluation Nomograph .....	63–64
Modeling and Simulation (M&S) Planning .....	65
Hierarchy of Models and Simulations.....	66
The Evolution of Modeling and Simulation.....	67
<b>PLANNING AND CONTROL TOOLS</b> .....	68–75
Gantt Chart (Example).....	68
Milestone Chart (Example).....	68
Network Schedules.....	69
Network Schedules—General .....	69
Arrow Diagramming Method (ADM) .....	69
Precedence Diagramming Method (PDM).....	69
Network Schedules (Example).....	70
Examples of Network Scheduling Software .....	71
Schedule Development .....	72
Lead Time Chart .....	73
Line of Balance Technique .....	74
Acquisition Program Baseline .....	75
<b>RISK MANAGEMENT</b> .....	76–79
Program Manager’s Checklist for Review of Tradeoff Planning and Studies.....	76
Technical Performance Measurement .....	76
DoD Risk Management Process Model .....	77
Root Cause Analysis.....	77
Risk Management Process—Details.....	78
Program Success Metrics Model * Summary .....	79

**CHAPTER 1—ACQUISITION MANAGEMENT (CONTINUED)**

**SYSTEMS ENGINEERING** ..... 80–98

What is Systems Engineering? ..... 80

Systems Engineering Processes ..... 80

Systems Engineering Policy in DoD..... 80

Systems Engineering Process—Technical Management Processes..... 81

Defense Acquisition Management System—Technical “V” Activities..... 82

Materiel Solution Analysis Phase Systems Engineering SE Activities..... 83

Technology Development Phase SE Activities..... 83

Engineering and Manufacturing Development Phase (SE) Activities ..... 84

Production and Deployment Phase—SE Activities..... 85

Operations and Support Phase—SE Activities ..... 85

Requirements (User Needs) Analysis Questions..... 86

Attributes of a Well-Defined Requirement..... 86

Systems Engineering Design Process Illustrated..... 87

Specification Development and Technical Reviews..... 88

Technical Management Processes Key Questions..... 89

Technical Review Definitions..... 90–91

Technical Review Best Practices..... 92

Program-Unique Specifications..... 93

Performance vs. Detail Specifications..... 94

Configuration Management..... 95

Interface Management..... 96

Interface Control Concept..... 96

Work Breakdown Structure (WBS)..... 97

How to Create a Work Breakdown Structure ..... 98

Basic Purposes of WBS ..... 98

**SOFTWARE** ..... 99–102

Software Development—Technical Review Relationships ..... 99

Software Development—Key Life Cycle Review Factors ..... 100

Candidate Software Measures (Metrics)..... 101

Quality Events for Software ..... 101

Software Management Best Practices..... 102

Software Acquisition Worst Practices..... 102

**CHAPTER 2—LEADERSHIP AND MANAGERIAL SKILLS..... 103**

Management and Leadership..... 103

Program Management “Diamond Card”..... 104–105

    Management..... 104

    Leadership ..... 104

    Technology Readiness Levels ..... 105

Empowerment, Delegation, and Coaching ..... 106–107

Coaching Skills ..... 107

Generic Integrated Product Team (IPT) Process ..... 108

Formula for Effective Team Performance..... 109

Team Charter ..... 110

**CHAPTER 2—LEADERSHIP AND MANAGERIAL SKILLS (CONTINUED)**

Working Groups.....	111–112
Team Development Wheel .....	111
Typical Working Groups.....	112
Management Tradeoffs for Working Groups .....	112
Team Performance Model .....	112
Team Decision Making .....	113
Effective Meetings .....	114
Decision Briefing.....	115
Communications.....	116–118
Counseling.....	118
Time Management.....	119
Management Tools and Techniques.....	120–121
Continuous Process Improvement/Lean Six Sigma (CPI/LSS).....	122

**CHAPTER 3—PROBLEM-SOLVING TOOLS ..... 123**

Brainstorming.....	123–124
Cause-and-Effect Diagram .....	125
Force Field Analysis .....	126
Histogram .....	127
Scatter Diagram .....	128
Surveys.....	129
Affinity Diagram .....	130
Pairwise Ranking.....	131–132
Pareto Chart.....	133
Benchmarking.....	134
Flowcharting .....	135–136
Deployment Flowcharts.....	137
Nominal Group Technique (NGT).....	138–139
Creative Problem Solving.....	140
Responsibility Assignment Matrix (RAM) .....	141
Knot Chart.....	142
Qualitative Problem Solving .....	143
Gantt Chart .....	144



## CHAPTER 1

### ACQUISITION PROCESSES AND RESOURCES

- **Things that make you go “Hmmm?...”**



- ✓ The only thing most auditors fix is the blame.
- ✓ Experience is something you got just after you needed it.
- ✓ People are smarter than they look; listen to them.
- ✓ The last 10 percent of the performance sought generates one-third of the cost and two-thirds of the problems.
- ✓ Never open a can of worms unless you want to go fishing.
- ✓ Those who believe it cannot be done, will you please get out of the way of those who are busy doing it?

- **Things we should always remember.**

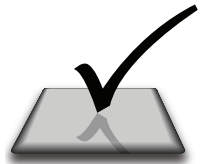

- ✓ Be honest in everything you say, write, and do.
- ✓ Be good to your people, and they will be good to you.
- ✓ Forgiveness is easier to obtain than permission.
- ✓ Keep everyone informed; when in doubt, coordinate.
- ✓ Be the first to deliver bad news.
- ✓ Bad news does not get any better with time.
- ✓ If you are sitting at your desk, you are not managing your program.

## **THE PROGRAM MANAGER'S BILL OF RIGHTS AND RESPONSIBILITIES**

### **Rights:**

Program Managers have the RIGHT to:

- a single, clear line of authority from the Defense Acquisition Executive;
- authority commensurate with their responsibilities;
- timely senior leadership decisions;
- be candid and forthcoming without fear of personal consequences;
- speak for their program and have their judgments respected;
- receive the best available training and experience for the job; and
- be given adequate financial and personnel resources.

### **Responsibilities:**

Program Managers have the RESPONSIBILITY to:

- accept program direction from acquisition executives and implement it expeditiously and conscientiously;
- manage their programs to the best of their abilities within approved resources;
- be customer-focused and provide the user with the best, most cost-effective systems or capabilities;
- innovate, strive for optimal solutions, seek better ways to manage, and provide lessons-learned to those who follow;
- be candid about program status, including risks and problems as well as potential solutions and likely outcomes;
- prepare thorough estimates of financial and personnel resources that will be required to manage the program; and
- identify weaknesses in the acquisition process and propose solutions.

## DEFENSE ACQUISITION MANAGEMENT SYSTEM (DoDI 5000.02)

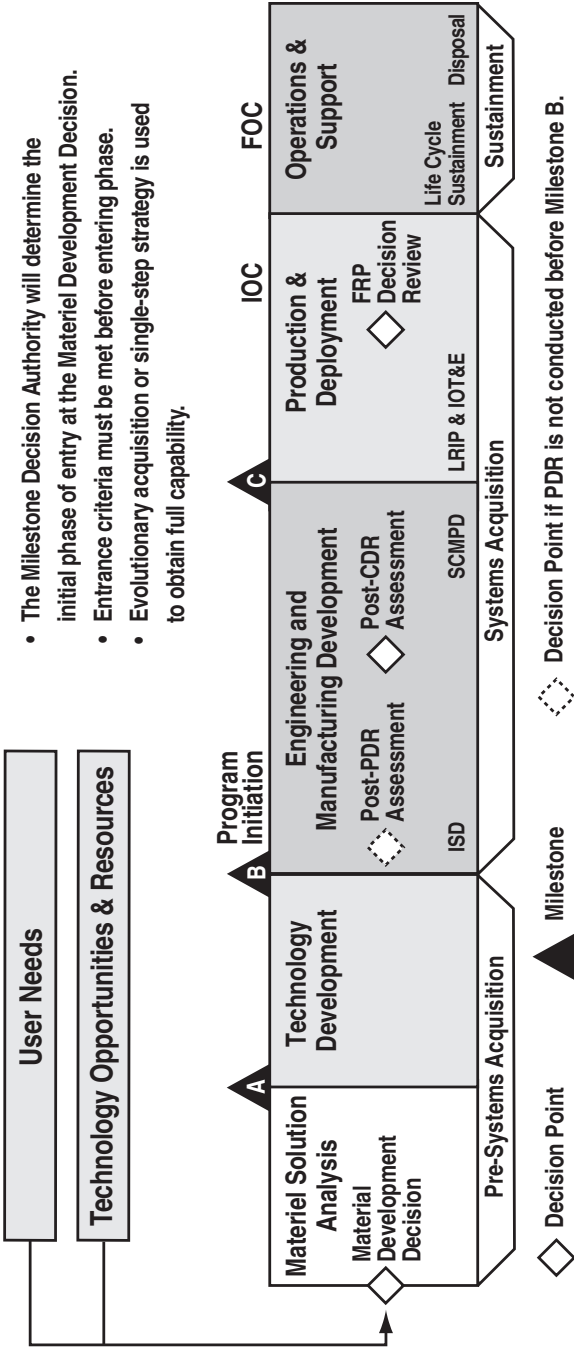

- The Milestone Decision Authority will determine the initial phase of entry at the Materiel Development Decision.
- Entrance criteria must be met before entering phase.
- Evolutionary acquisition or single-step strategy is used to obtain full capability.

## ACQUISITION CATEGORIES (ACAT)

<b>Major Defense Acquisition Programs</b>	<b>ACAT ID:</b>	<ul style="list-style-type: none"> <li>• DAB Review</li> <li>• Designated by USD(AT&amp;L)</li> <li>• Decision by USD(AT&amp;L)</li> </ul>	<div style="border: 1px solid black; padding: 5px;">                     \$365M RDT&amp;E or \$2.190B Procurement (FY 00 Constant \$)                 </div>
	<b>ACAT IC:</b>	<ul style="list-style-type: none"> <li>• Component Review</li> <li>• Designated by USD(AT&amp;L)</li> <li>• Decision by Component Head/CAE</li> </ul>	
<b>Major AIS Acquisition Programs</b>	<b>ACAT IAM:</b>	<ul style="list-style-type: none"> <li>• ITAB Review</li> <li>• Designated by USD(AT&amp;L)*</li> <li>• Decision by USD(AT&amp;L)*</li> </ul>	<div style="border: 1px solid black; padding: 5px;">                     \$378M Life Cycle Cost or \$126M Total Program Cost or \$32M Program Cost in any single year (FY 00 Constant \$)                 </div>
	<b>ACAT IAC:</b>	<ul style="list-style-type: none"> <li>• Component Review</li> <li>• Designated by USD(AT&amp;L)*</li> <li>• Decision by Component Head/CAE</li> </ul>	
<b>Major Systems</b>	<b>ACAT II:</b>	<ul style="list-style-type: none"> <li>• Does Not Meet ACAT I Criteria</li> <li>• Designated by Svc Sec/CAE</li> <li>• Decision by Svc Sec/CAE</li> </ul>	<div style="border: 1px solid black; padding: 5px;">                     \$140M RDT&amp;E or \$660M Procurement (FY 00 Constant \$)                 </div>
<b>All Others</b> (except Navy and USMC)	<b>ACAT III:</b>	<ul style="list-style-type: none"> <li>• Does Not Meet ACAT I, IA, or II Criteria</li> <li>• Designated IAW Component Policy</li> <li>• Decision IAW Component Policy</li> </ul>	<div style="border: 1px solid black; padding: 5px;">                     No Fiscal Criteria                 </div>
<b>Navy USMC</b>	<b>ACAT IV:</b>	<ul style="list-style-type: none"> <li>• Not otherwise designated ACAT I, IA, II, or III</li> <li>• Designated IAW Navy Policy</li> <li>• Navy/USMC ACAT IVT/IVM</li> <li>• Decision at lowest appropriate level</li> </ul>	<div style="border: 1px solid black; padding: 5px;">                     SECNAVINST 5000.2_                 </div>

**LEGEND:**

ACAT— Acquisition Category	ITAB— Information Technology Acquisition Board
AIS— Automated Information System	RDT&E— Research, Development, Test, and Evaluation
CAE— Component Acquisition Executive	USD(AT&L)— Under Secretary of Defense
DAB— Defense Acquisition Board	(Acquisition, Technology and Logistics)

\* May be delegated

## ACQUISITION STRATEGY CONSIDERATIONS

(*Defense Acquisition Guidebook, Chapter 2*)

- Acquisition Approach
  - Modular Open Systems Approach Summary
  - Tailoring
- Source & Related Documents
- Capability Needs
- Top-Level Integrated Schedule
  - EMD Top-Level Schedule \*
  - MS C & FRP Top-Level Schedule \*
- Program Interdependency & Interoperability Summary
- International Cooperation
  - Test Requirements for Export of Defense Systems
- Risk & Risk Management
- Technology Maturation
- Industrial Capability & Manufacturing Readiness
  - Industrial Capability
  - Elevating Industrial Capability Issues
  - Industrial & Manufacturing Readiness
  - Sustaining Industrial Capabilities
- Business Strategy
  - Small Business & Small Business Innovation Research
    - ◆ Subcontracting Plan/Small Business Participation
    - ◆ Performance Measurement
    - ◆ Small Business Innovation Research Considerations
  - Contract Approach
    - ◆ Performance-Based Business Strategy
      - Modular Contracting
    - ◆ Contracting Bundling or Consolidation
    - ◆ Major Contract(s) Planned
      - Contract Type Selection
      - Sustainment Procurement Strategy
    - ◆ Multi-Year Contracting
    - ◆ Contract Incentives
    - ◆ Warranties
- ◆ Leasing
- ◆ Developmental Testing Requirements
- ◆ Incorporation of Systems Engineering Requirements
- Market Research
- Competition
- Resource Management
  - PM Office Staffing & Support Contractors
  - Cost & Funding
  - Cost Control & CAIV Plan
  - Earned Value Management
  - Advanced Procurement
- Program Security Considerations
  - Information Assurance
  - Critical Program Information & Program Protection Plan Summary
  - Anti-Tamper Measures
  - Supply Chain Risk Management Key Practices
- Test and Evaluation
- Data Management
  - Data Management & Technical Data Rights
    - Integrated Data Management
- Life-Cycle Sustainment Planning
  - LCSP Executive Summary for Acquisition Strategy
- Life-Cycle Signature Support Plan
- Chemical, Biological, Radiological and Nuclear Survivability
- Human Resources Integration
- Environment, Safety and Occupational Health (ESOH)
- Military Equipment Valuation & Accountability
  - Proper Financial Accounting Treatment for Military Equipment
  - Accounting Review
- Corrosion Prevention & Control Plan/ Strategy

**NOTES:** 1) The content of the Technology Development Strategy (TDS) due at Milestone A is very similar to the Acquisition Strategy due at Milestone B. 2) In addition to the Acquisition Strategy, there are five plans required: Acquisition Plan (FAR/DFARS), Program Protection Plan (PPP), Test and Evaluation Master Plan (TEMP) (DoDI 5000.02), Information Support Plan (ISP) (CJCSI 6212.01E), and Systems Engineering Plan (DoDI 5000.02).

## ACQUISITION, TECHNOLOGY AND LOGISTICS (AT&L) KNOWLEDGE MANAGEMENT SYSTEM

< <https://acc.dau.mil/at&lkm> >

**(Composed of the following subsystems)**

### Defense Acquisition Portal (DAP)



The Defense Acquisition Portal (DAP) <<https://dap.dau.mil/>> was launched to replace the AT&L (Acquisition, Technology, and Logistics) Knowledge Sharing System (AKSS). Like its predecessor, DAP continues to provide acquisition information for all DoD service components and across all functional disciplines. DAP serves as the central point of access for all AT&L resources and information, and to communicate acquisition reform. As the primary reference tool for the Defense Acquisition workforce, it provides a means to link together information and reference assets from various disciplines into an integrated, but decentralized, information source. Information is organized under eight major tabs: Home, Acquisition Process, Workforce, Policy, Communities of Practice, Training and Education, Industry, and DAU. DAP is one part of the AT&L Knowledge Management System (AKMS).

A major feature in DAP is the Acquisition Career Gateways <<https://dap.dau.mil/career/Pages/Default.aspx>>, where each acquisition career field provides specific career, training, and job-specific information and resources. To tie it all together, the Search feature has been reengineered to make it easier to find specific learning assets or job support tools in the Portal.

### Ask A Professor (AAP)



Ask a Professor (AAP) <<https://akss.dau.mil/aap>> is a service offered as part of AKMS. Users submit acquisition-related questions and receive formal responses. In addition, the AAP contains a database of questions and answers that are categorized by subject area and can be browsed or searched.

### Acquisition Community Connection (ACC)



The ACC <<https://acc.dau.mil/>> is the collaborative component of the AKMS that focuses on acquisition-related topics and disciplines such as contracting, logistics, program management, and risk management. It consists of Communities of Practice, Special Interest Areas, and collaborative workspaces that:

- connect people with know-how across DoD organizations and industry;

- enable members to interact and share resources, ideas, and experiences to support job performance and avoid duplication of effort; and
- identify partnership development opportunities.

Members may request workspaces in ACC, which provide a way for physically dispersed individuals to centrally locate and share documents and references as well as manage team projects. To learn more, go to the ACC <<https://acc.dau.mil/>> and take the online virtual tour.

## Defense Acquisition Guidebook (DAG)



The DAG <<https://acc.dau.mil/dag>> provides links to policy, law, and useful content housed in communities of practice. It allows users to navigate through the DAG via a document index, graphical interface (Life Cycle System), or a search by topic.

## ACQuipedia



The ACQuipedia <<https://acquipedia.dau.mil/>> is your acquisition encyclopedia for common defense acquisition topics. Each topic is identified as an article; each article contains a definition, a brief narrative that provides context, and links to the most pertinent policy, guidance, tools, practices, and training. Articles aggregate the most relevant references and learning assets to narrowly focus users and quickly provide high-value content.

## Integrated Defense AT&L Life Cycle Management System Chart

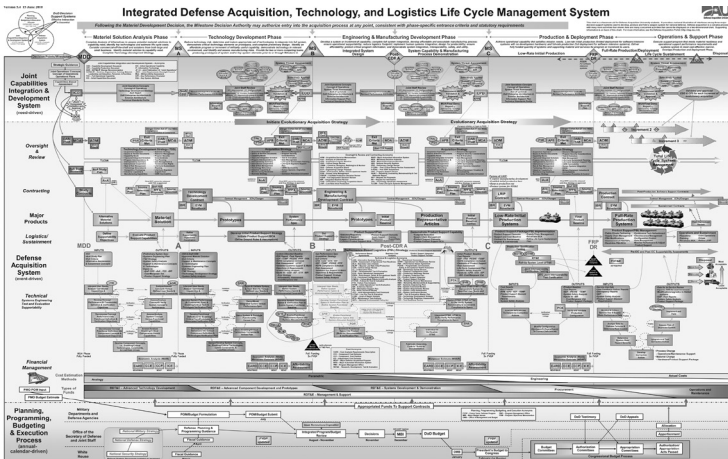

(See next page for details)



This chart <<https://acc.dau.mil/ffc>> is a pictorial road map of key activities in the systems acquisition process. Users navigate through a graphical model of the three major acquisition process areas: Joint Capabilities Integration and Development System (JCIDS); Defense Acquisition; and Planning, Programming, Budgeting, and Execution (PPB&E). The short title for this chart is Integrated Life Cycle (ILC) Chart.

### **AT&L ACQuire**



ACQuire <<https://acquire.dau.mil/>> is a search tool focused on the specific needs of the Defense Acquisition Workforce. It uses the DAU acquisition taxonomy, trusted acquisition sites, and selected AT&L resources to enhance searches and derive better results. Searches can be conducted by individual or multiple sites; document titles; topic; content, via an index of major categories; and subcategories.

Courseware is also searchable via ACQuire. Users can suggest additional AT&L sites that should be included in ACQuire crawls.

### **Best Practices Clearinghouse (BPCh)**



The BPCh <<https://bpch.dau.mil/Pages/default.aspx>> is an innovative “clearinghouse” approach that will improve all DoD acquisition processes by helping AT&L professionals select and implement proven practices appropriate to the individual program needs. Initially, the BPCh will focus on software acquisition and systems engineering.

The Clearinghouse provides:

- an authoritative source for practices, lessons learned, and risks to avoid;
- validated practices with consistent, verifiable information;
- an active knowledge base to help with practice questions;
- an intelligent front-end to quickly get to answers;
- useful information and tools to help find, select, and implement practices appropriate to specific programs; and
- living knowledge through a constantly updated, expanded, and refined database.

### **Performance Learning Tools**

Performance Learning Tools (PLTs) link learning and job support assets to complicated process flow to help users create plans and other AT&L products accurately and efficiently. The following PLTs have been developed:

- Pricing Support Tool <<http://pricingtool.dau.mil/>>
- Performance-Based Logistics Toolkit <<https://acc.dau.mil/pbltoolkit>>

## DEFENSE ACQUISITION BOARD TIMELINE — MILESTONES B, C, AND FRPDR

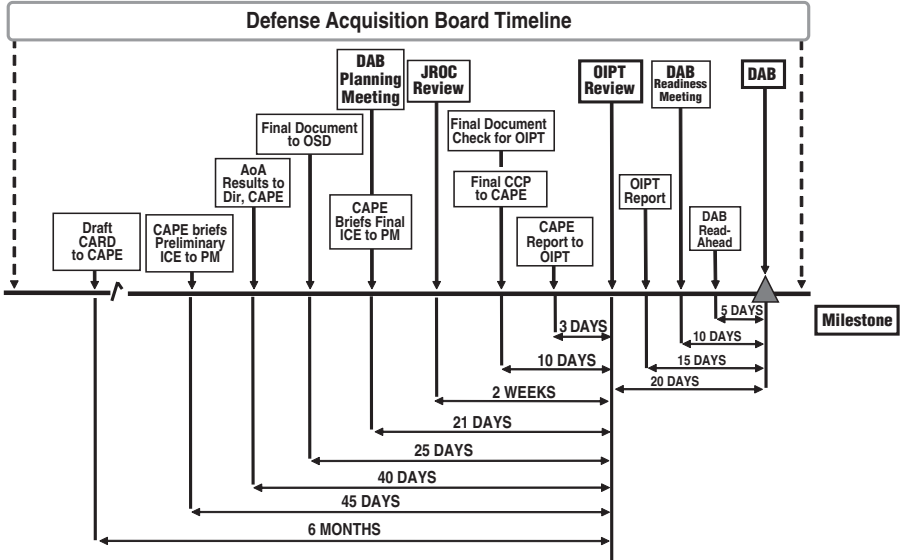

**LEGEND:**

CAPE—Cost Assessment & Program Evaluation	DAB—Defense Acquisition Board
CARD—Cost Analysis Requirements Description	ICE—Independent Cost Estimate
CCE—Component Cost Estimate	JROC—Joint Requirements Oversight Council

## MILESTONE DECISION INFORMATION — A POSSIBLE CONSTRUCT

<p><b>1</b></p> <p style="text-align: center;"><b>WHY?</b></p> <ul style="list-style-type: none"> <li>• Threat</li> <li>• Capability</li> </ul>	<p><b>2</b></p> <p style="text-align: center;"><b>WHAT?</b></p> <ul style="list-style-type: none"> <li>• Requirement</li> <li>• Analysis of Alternatives</li> </ul>	<p><b>3</b></p> <p style="text-align: center;"><b>HOW?</b></p> <ul style="list-style-type: none"> <li>• Acquisition Strategy</li> </ul>
<p><b>4</b></p> <p style="text-align: center;"><b>RISKS?</b></p> <ul style="list-style-type: none"> <li>• Risk Management Plan</li> <li>• Test &amp; Evaluation Plan</li> <li>• Test &amp; Evaluation Results</li> </ul>	<p><b>5</b></p> <p style="text-align: center;"><b>COSTS?</b></p> <ul style="list-style-type: none"> <li>• CAIV Objectives</li> <li>• Life Cycle Cost Estimate</li> <li>• Independent Cost Estimate</li> </ul>	<p><b>6</b></p> <p style="text-align: center;"><b>MANAGEMENT?</b></p> <ul style="list-style-type: none"> <li>• Program Management Office Structure</li> <li>• Integrated Product Team</li> <li>• WIPT—OIPT Structure</li> </ul>
<p><b>7</b></p> <p style="text-align: center;"><b>AGREEMENT?</b></p> <ul style="list-style-type: none"> <li>• Acquisition Program Baseline</li> <li>• Acquisition Decision Memorandum</li> <li>• Exit Criteria</li> </ul>	<p><b>LEGEND:</b></p> <p>CAIV—Cost as an Independent Variable</p> <p>OIPT—Overarching Integrated Product Team</p> <p>WIPT—Working-Level Integrated Product Team</p>	

- Have I presented all necessary information?
- Is the information clear and accurate?
- Does the information flow logically?
- Is it concise, executive-level information?

## REQUIREMENTS FOR MILESTONE/DECISION REVIEWS

See encl 4, DoDI 5000.02

Requirement	Milestone/Decision Point					
	MDD	A	B	P-CDRA	C	FRP
Acquisition Decision Memorandum <sup>5</sup>	X	X	X	X	X	X
Acquisition Program Baseline <sup>5</sup>			X		X	X
Acquisition Strategy <sup>5</sup> (see Page 5)			X		X	X
Acquisition Information Assurance Strategy (all IT incl NSS)		X	X		X	X
Affordability Assessment			X		X	
Alternate LF T&E Plan (programs with waiver from full-up LFT&E) <sup>2</sup>			X			
Analysis of Alternatives (AoA) <sup>3,5</sup>		X	X		X	X
AoA Study Guidance	X					
Benefit Analysis & Determination <sup>1,8</sup> (bundled acquisitions)			X			
Beyond LRIP Report <sup>2</sup> (incl MDAPs that are also MAIS)						X
Capability Development Document (CDD) <sup>5</sup>			X			
Capability Production Document (CPD)					X	
Clinger-Cohen Act (CCA) Compliance <sup>5,7</sup>		X	X		X	X
Competition Analysis <sup>1,8</sup> (depot-level maintenance rule)			X			
CIO Confirmation of CCA Compliance (DoD CIO for MAIS and MDAP)		X	X		X	X
Component Cost Estimate <sup>5,9</sup> (MAIS; optional MDAP)		X	X			X
Consideration of Technology Issues (MDAP & MAIS)		X	X		X	
Cooperative Opportunities <sup>1</sup>		X	X		X	
Core Logistics/Source of Repair Analysis <sup>1,8</sup>			X		X	
Corrosion Prevention Control Plan <sup>1</sup>			X		X	
Cost Analysis Requirements Description <sup>5,9</sup> (MDAP & MAIS)			X		X	X
Data Management Strategy <sup>1</sup> (MDAP, MAIS & ACAT II)		X	X		X	X
Economic Analysis (MAIS) <sup>7</sup> (may be combined w/AoA at MSA)		X	X			X
Exit Criteria <sup>5</sup>		X	X		X	X
Industrial Base Capabilities <sup>1</sup> (MDAPs only)		X	X		X	
Independent Cost Estimate (ICE) <sup>5,10,15</sup> (MDAPs only)		X	X		X	X
Independent Technology Readiness Assessment <sup>11</sup>			X		X	
Information Support Plan <sup>1,5</sup>			X	X	X	
Initial Capabilities Document (ICD) <sup>4,5</sup>	X	X	X		X	
Initial Operational Test & Evaluation Completed (ACAT I & II)						X
Item Unique Identification (IUID) Plan (Part of SEP)		X	X		X	
Joint Interoperability Test Certification (IT & NSS)						X
Life-Cycle Signature Support Plan <sup>5</sup>		X	X		X	
Life-Cycle Sustainment Plan <sup>1</sup>			X		X	X
LF T&E Waiver <sup>2</sup> (covered systems) (n/a MAIS)			X			
LF T&E Report <sup>2</sup> (covered systems) (n/a MAIS)						X

## DAU PROGRAM MANAGERS TOOL KIT

Requirement	Milestone/Decision Point					
	MDD	A	B	P-CDRA	C	FRP
LRIP Quantities MDAP & ACAT II (n/a AIS)			X			
Manpower Estimate (MDAPS only) <sup>5</sup>			X		X	X
Market Research		X	X			
Milestone Decision Authority (MDA) Certification (MDAPs only) <sup>4</sup>		X	X		X	
MDA assessment of chem, bio, rad, and nuc survivability			X		X	
Military Equipment Validation <sup>1</sup>					X	X
Net-Centric Data Strategy <sup>5,12</sup>		X	X		X	
Operational Test Agency Report of OT&E Results			X		X	X
Preliminary Design Review (PDR) Report <sup>16</sup>			X			
Post-Critical Design Review (CDR) Report				X		
Post Implementation Review						X
Program Protection Plan (PPP) <sup>1</sup>		X	X		X	
Prog Environment, Safety & Occup Health Evaluation (PESHE) <sup>5</sup>			X		X	X
Replaced System Sustainment Plan <sup>5</sup> (MDAPs only)			X			
Selected Acquisition Report (SAR) <sup>4,13</sup>						
Spectrum Supportability Determination <sup>9</sup>			X		X	
System Threat Assessment (STA) (ACAT II) <sup>5,14</sup>			X		X	
System Threat Assessment Report (STAR) (ACAT I) <sup>5,6</sup>			X		X	
Systems Engineering Plan (SEP)		X	X		X	
Technology Development Strategy (TDS)		X	X		X	
Technology Readiness Assessment (TRA) <sup>5</sup>			X		X	
Test & Evaluation Master Plan (TEMP)			X		X	X
Test & Evaluation Strategy (TES)		X				

<sup>1</sup>Part of TDS or Acquisition Strategy

<sup>2</sup>OSD T&E Oversight Programs

<sup>3</sup>MDAP: A,B,C; MAIS: A, B, FRP

<sup>4</sup>Milestone C if Program Initiation

<sup>5</sup>Program Initiation for Ships

<sup>6</sup>Validated by DIA for ACAT ID; AIS use DIA validated capstone info/ops Threat Assessment Decision

<sup>7</sup>Milestone C if equivalent to FRP

<sup>8</sup>Milestone C if no Milestone B

<sup>9</sup>MAIS whenever an economic analysis is required

<sup>10</sup>May be CAIG Assessment at Milestone A

<sup>11</sup>ACAT ID only if required by DDR&E

<sup>12</sup>Summarized in TDS; details in ISP

<sup>13</sup>SAR at program initiation; annually thereafter

<sup>14</sup>Validated by Component; AIS use DIA validated capstone info/ops Threat Assessment Decision

<sup>15</sup>MDA may request cost assessment at Milestone A

<sup>16</sup>If PDR is after Milestone B, MDA will conduct a post-PDR assessment review

# INTEROPERABILITY CERTIFICATION (CJCSI 6212.01E)

IT and NSS employed by U.S. Forces shall, where required (based on capability context), interoperate with existing and planned, systems and equipment, of joint, combined and coalition forces and with other U.S. Government Departments and Agencies, as appropriate.  
DoD Directive 4630.08

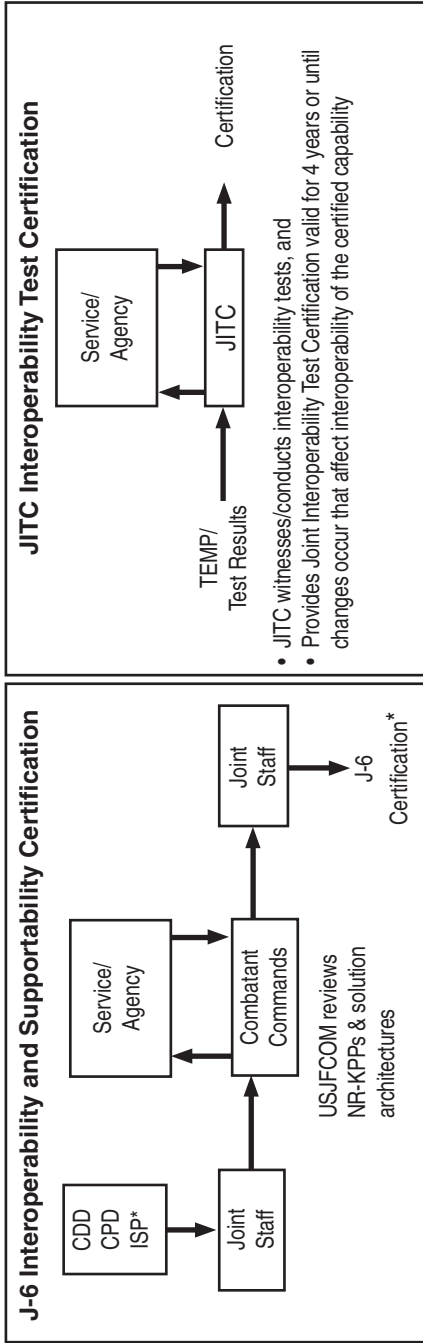

**LEGEND:**

CDD — Capability Development Document	ISP — Information Support Plan	TEMP — Test and Evaluation Management Plan
CPD — Capability Production Document	JITC — Joint Interoperability Test Command	*NR-KPP certification

# S&T LINKAGE TO DEFENSE ACQUISITION PROCESS

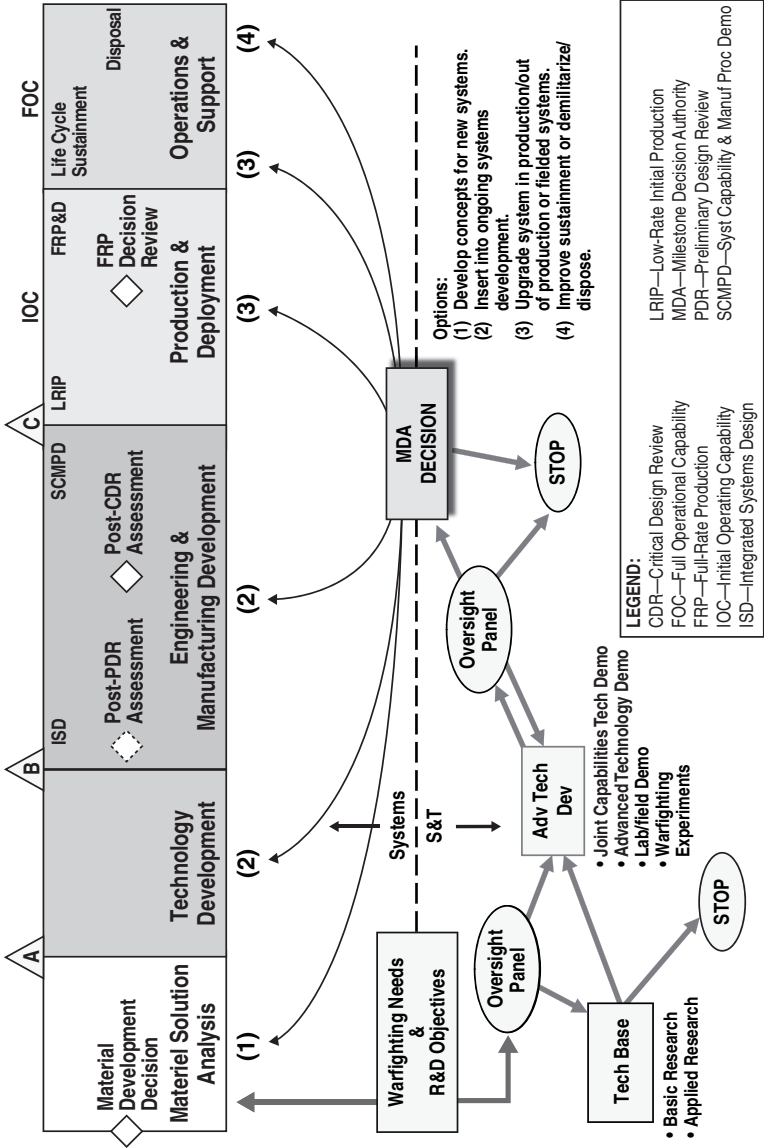

## JOINT CAPABILITIES TECHNOLOGY DEMONSTRATION (JCTD)

### JCTD Identification, Selection, and Review

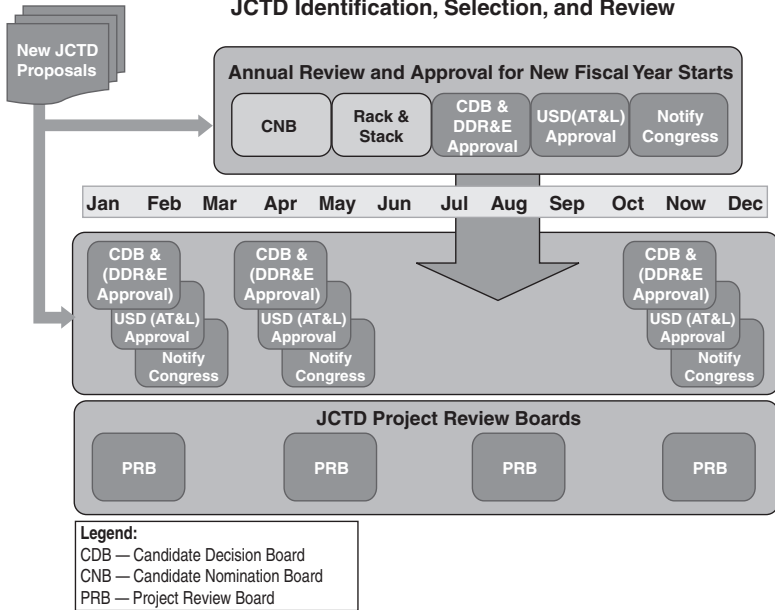

## JCTD EXECUTION APPROACH

Annual call for proposals; proposals submitted at any time

- Candidate projects identified by Combatant Commands, Services and Agencies, Interagency or Coalition Partners, and industry
- Joint/Interagency Government-led teams build proposals
- Technical manager from Service or Agency
- Operational manager from Combatant Command chain-of-command
- Transition manager from Acquisition Community
- USD(AT&L) approval of recommended new starts
- Congressional Notification
- DDR&E/Rapid Fielding Directorate oversight during project execution
- Operational demonstration and rigorous assessment
- Continuous transition of capabilities demonstrating required capabilities

Beginning in FY10:

- Quarterly Candidate Decision Boards to recommend new starts, chaired by DDR&E, co-chaired by Joint Staff Deputy J8
- Quarterly Review Boards to review ongoing projects
- More short projects (1 year or less); fewer long-term projects (more than 1 year)
- All projects structured for deliverables in first year, with annual review
- JROC validation following first year of execution

**ACQUISITION PROGRAM vs. ATD AND JCTD**

	<b>Acquisition Program</b>	<b>Advanced Technology Demonstration (ATD)</b>	<b>Joint Capability Tech Demonstration (JCTD)</b>
<b>Motivation</b>	<ul style="list-style-type: none"> <li>Develop, produce, and field system</li> <li>Cost, schedule, performance</li> </ul>	<ul style="list-style-type: none"> <li>Demonstrate feasibility and maturity</li> <li>Reduce technical risks and uncertainties at relatively low cost</li> </ul>	<ul style="list-style-type: none"> <li>Gain understanding of and evaluate utility prior to acquisition decision</li> <li>Develop concepts of operation and doctrine</li> </ul>
<b>Documented Need</b>	ICD/CDD/CPD	Not Required	JROC Approval and Prioritization
<b>Oversight</b>	Milestone Decision Authority	Service-Level Labs/R&D Centers	DDR&E Oversight Panel with Joint Staff
<b>Funding</b>	Fully FYDP Funded	RDT&E	RDT&E (2 years in field)
<b>ACAT</b>	All ACAT	Not ACAT Effort	Not ACAT Effort
<b>Configuration and Testing</b>	System/Subsystem Prototypes DT/OT	Technology Demonstrations	Tech Demonstrations in Field Environment/MUA
<b>Rules</b>	DoD 5000 Series/FAR	Informal/FAR/OTA	Implementation Directive/FAR/OTA
<b>Role of User</b>	Max Involvement	Some Involvement	Max Involvement

<b>LEGEND:</b>	DT/OT—Developmental/Operational Testing	MUA—Military Utility Assessment
ACAT—Acquisition Category	FAR—Federal Acquisition Regulation	
CDD—Capability Development Document	FYDP—Future Years Defense Program	
CPD—Capability Production Document	ICD—Initial Capabilities Document	
DDR&E—Director, Defense Research & Engineering		

**PROGRAM STRUCTURE** (Example—No Streamlining)

	FY01	FY02	FY03	FY04	FY05	FY06	FY07	FY08	FY09	FY10	FY11	FY12	FY13	FY14
Milestone Reviews & Phases	MSA	Tech Dev	Eng & Manuf Development	ISD	SCMPD	LRIP	LRIP	LRIP	LRIP	LRIP	LRIP	LRIP	LRIP	LRIP
	MDD	A	B	Post-PDR A	Post-CDR A	C	C	FRP	FRP	FRP	FRP	FRP	FRP	FRP
			Prototype Competition											
Contract Award (Increment 1)														
Technical Reviews (Increment 1)														
Testing (Increment 1)														
Deliveries (Increment 1)														
RDT&E														
Procurement														
O&M														
MILCON														

## DOD INTERNATIONAL ARMAMENTS COOPERATION POLICY

“PMs shall pursue international armaments cooperation to the maximum extent feasible, consistent with sound business practice and with the overall political, economic, technological, and national security goals of the United States. International agreements for international armaments cooperation programs shall complete the interagency consultation and Congressional notification requirements contained in 10 U.S.C. 2350a, Section 2751 of the Arms Export Control Act, and 10 U.S.C. 2531.”

— DoDD 5000.01 (Para E1.1.1)

### THE SCOPE OF DEFENSE COOPERATION

<b>RDT&amp;E</b>	<b>Production and Procurement</b>	<b>Follow-on Support</b>
Information Exchanges	Foreign Military Sales	Cooperative Logistics Supply Support
Engineer and Scientist Exchanges	Direct Commercial Sales Exchanges	Mutual Support
Cooperative R&D	Cooperative Production (Joint Funds)	Logistics Support
Comparative or Joint Testing	Coproduction/Licensing (Foreign Funds)	Host Nation Support Defense Industrial Base
Standardization	Reciprocal Procurement	



***The Program Manager's Focus***

## DEFENSE SALES vs. COOPERATIVE ACQUISITION

*They are Different*

- |   |   |
|---|---|
| <ul style="list-style-type: none"> <li>• <b>Defense Sales</b></li> <li>– Any Nation</li> <li>– U.S. Contracts (FMS)</li> <li>– U.S. Manages (FMS)</li> <li>– Production and Support</li> <li>– Dept. of State or Dept. of Commerce + DoD (USD(Policy))</li> <li>– Foreign Initiated</li> <li>– Foreign Funds (or U.S. Credit/Grants)</li> </ul> | <ul style="list-style-type: none"> <li>• <b>Cooperative Acquisition</b></li> <li>– Allied or Friendly</li> <li>– U.S., Ally or NATO</li> <li>– Jointly Managed</li> <li>– All Acquisition</li> <li>– DoD (USD(AT&amp;L)) + Dept. of State and Dept. of Commerce</li> <li>– U.S. and/or Foreign Initiated</li> <li>– Foreign + U.S. Funds</li> </ul> |
|---|---|

### INTERNATIONAL ACTIVITIES ASSOCIATED WITH DEFENSE ACQUISITION PHASES

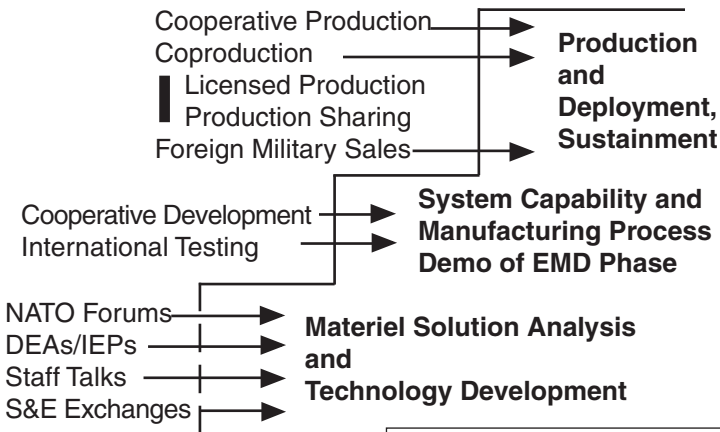

**Technology Opportunities and User Capability Needs**

**LEGEND:**  
 DEA—Data Exchange Agreement  
 EMD—Engineering & Manufacturing Development  
 IEP—Information Exchange Project  
 S&E—Science and Engineering

**RESOURCE ALLOCATION PROCESS—OVERLAP**

	CY11												CY12												CY13											
	J	F	M	A	M	J	J	A	S	O	N	D	J	F	M	A	M	J	J	A	S	O	N	D	J	F	M	A	M	J	J	A	S	O	N	D
FY11	Execution FY11 & prior																																			
FY12	Enactment FY12												Enactment FY12 & prior																							
FY13	Planning DPPG FY13-17 POM FY13-17 BES FY13												Enactment FY13												Execution FY13 & prior											
FY14	Planning DPPG FY14-18												Programming & Budgeting POM FY14-18 BES FY14												Enactment FY14											
FY15													Planning DPPG FY15-19												Programming & Budgeting POM FY15-19 BES FY15											

**LEGEND:**  
 DPPG—Defense Planning & Programming Guidance  
 POM—Program Objectives Memorandum

PB—President's Budget  
 BES—Budget Estimate Submission

## PPBE—PLANNING PHASE

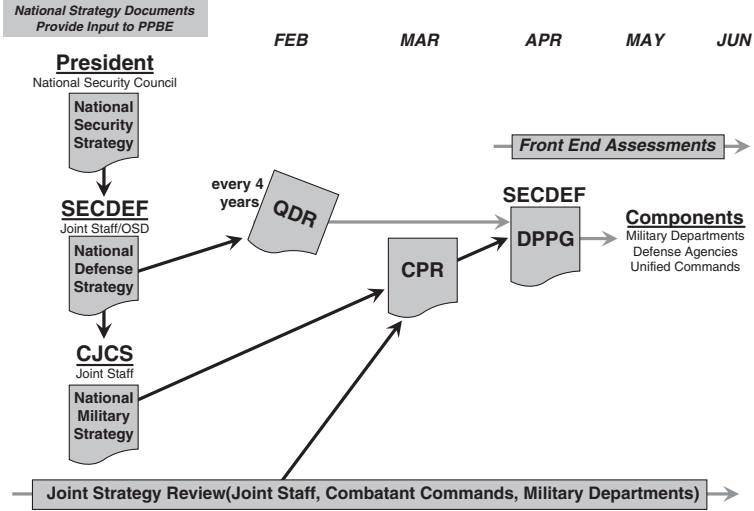

**LEGEND:**

CPR—Chairman’s Program Recommendation      DPPG—Defense Planning & Programming Guidance  
 CJCS—Chairman, Joint Chiefs of Staff      QDR—Quadrennial Defense Review

## PPBE—PROGRAM/BUDGET REVIEW

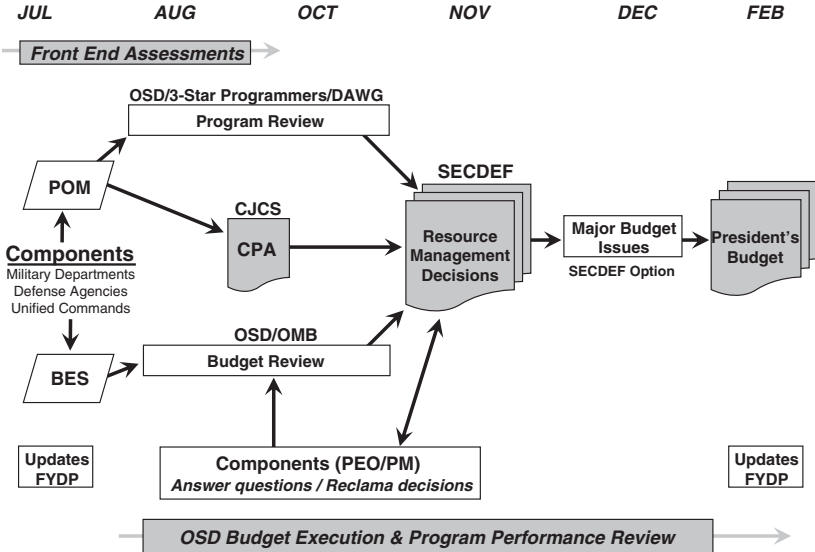

**LEGEND:**

BES—Budget Estimate Submission      FYDP—Future Years Defense Program  
 CPA—Chairman’s Program Assessment      POM—Program Objectives Memorandum  
 DAWG—Deputy’s Advisory Working Group

RESOURCE ALLOCATION PROCESS

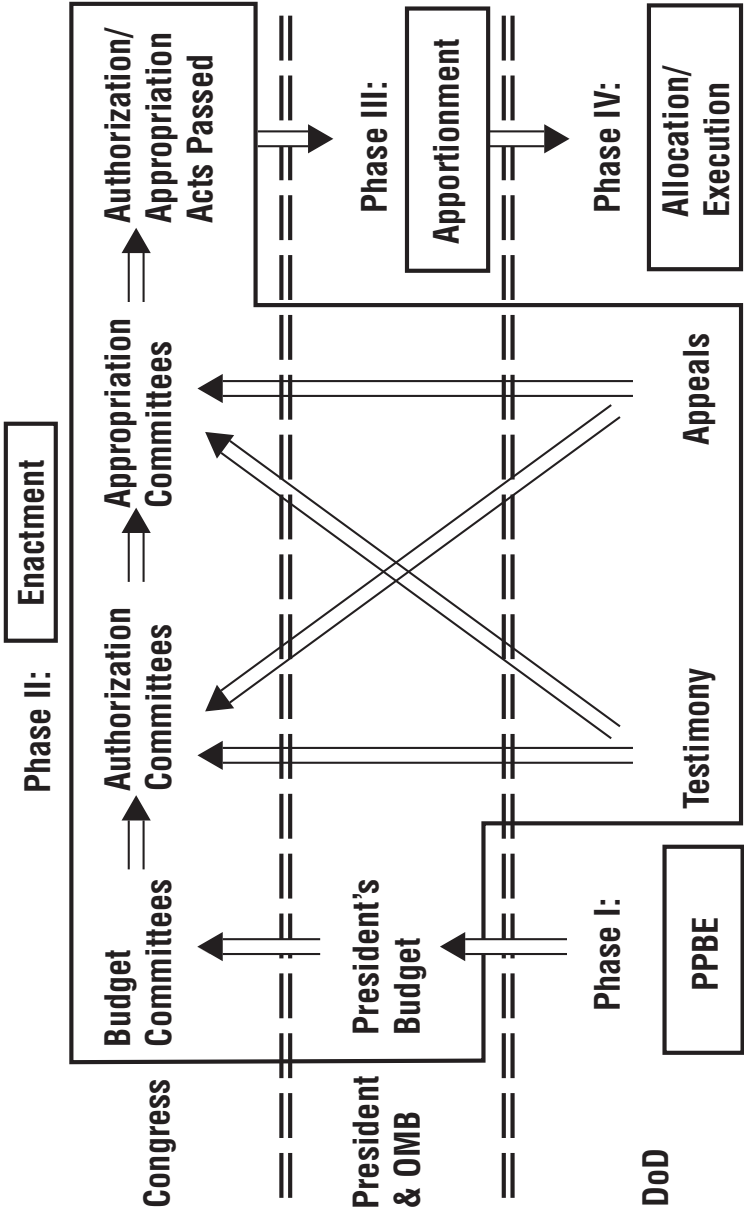

**CONGRESSIONAL ENACTMENT TIMETABLE**

	JAN	FEB	MAR	APR	MAY	JUN	JUL	AUG	SEP	OCT
		^		15	15					
	PRES BUDGET COMMITTEE INPUTS									
BUDGET RESOLUTION	HOUSE	HRNGS	MARKS	FLOOR						
	SENATE	HRNGS	MARKS	FLOOR ^	CONF RESOLUTION					
				FLOOR						
AUTHORIZATION	HOUSE		HASC HRNGS	MARK-UP	FLOOR	FLOOR	CONF/REPT			
	SENATE		SASC HRNGS	MARK-UP	FLOOR	FLOOR			ACT ^	
							BILL/RPT			
APPROPRIATION	HOUSE		HAC HRNGS	MARK-UP	FLOOR	FLOOR	CONF/REPT			ACT ^
	SENATE		SAC HRNGS	MARK-UP	FLOOR	FLOOR				BILL/RPT

"TARGET" FISCAL YEAR

**PROCUREMENT APPROPRIATIONS  
(Account Numbers and Budget Activities)**

**Appropriation**

**Budget Activity**

***Army (21 -)***

Aircraft	- 2031	1 Aircraft 2 Modification of Aircraft 3 Spares and Repair Parts 4 Support Equipment and Facilities
Missile	- 2032	1 Not Used 2 Other Missiles 3 Modification of Missiles 4 Spares and Repair Parts 5 Support Equipment and Facilities
Weapons and Tracked Combat Vehicles	- 2033	1 Tracked Combat Vehicles 2 Weapons and Other Combat Vehicles 3 Spares and Repair Parts
Ammo	- 2034	1 Ammo 2 Ammo Production Base Support
Other	- 2035	1 Tactical and Support Vehicle 2 Communications and Electronics 3 Other Support Equipment 4 Initial Spares

***Navy (17 -)***

Aircraft	- 1506	1 Combat Aircraft 2 Airlift Aircraft 3 Trainer Aircraft 4 Other Aircraft 5 Modification of Aircraft 6 Aircraft Spares and Repair Parts 7 Aircraft Support Equipment and Facilities
Weapons	- 1507	1 Ballistic Missiles 2 Other Missiles 3 Torpedoes and Related Equipment 4 Other Weapons 5 Not Used 6 Spares and Repair Parts
Ammo, Navy and Marine Corps	- 1508	1 Ammo, Navy 2 Ammo, Marine Corps
Shipbuilding and Conversion	- 1611	1 Not Used 2 Other Warships 3 Amphibious Ships 4 Not Used 5 Auxiliaries, Craft, and Prior-Year Program Costs
Other	- 1810	1 Ships Support Costs 2 Communications and Electronics Equipment 3 Aviation Support Equipment 4 Ordnance Support Equipment 5 Civil Engineering Support Equipment 6 Supply Support Equipment

**PROCUREMENT APPROPRIATIONS**  
**(Account Numbers and Budget Activities) (Continued)**

<b>Appropriation</b>	<b>Budget Activity</b>
Other (continued)	-1810 7 Personnel and Command Support Equipment 8 Spares and Repair Parts
<b>Marine Corps (17 -)</b>	
Procurement	- 1109 1 Not Used 2 Weapons and Combat Vehicles 3 Guided Missiles and Equipment 4 Communications and Electronics Equipment 5 Support Vehicles 6 Engineering and Other Equipment 7 Spares and Repair Parts
<b>Air Force (57 -)</b>	
Aircraft	- 3010 1 Combat Aircraft 2 Airlift Aircraft 3 Trainer Aircraft 4 Other Aircraft 5 Modification of In-Service Aircraft 6 Aircraft Spares and Repair Parts 7 Aircraft Support Equipment and Facilities
Missile	- 3020 1 Ballistic Missiles 2 Other Missiles 3 Modification of In-Service Missiles 4 Spares and Repair Parts 5 Other Support
Ammo	- 3011 1 Ammo 2 Weapons
Other	- 3080 1 Not Used 2 Vehicular Equipment 3 Electronics and Telecommunications Equipment 4 Other Base Maintenance and Support Equipment 5 Spares and Repair Parts
<b>Defense (97 -)</b>	
Defense-wide	- 0300 1 Major Equipment 2 Special Operations Command 3 Chemical/Biological Defense
National Guard and Reserve Equipment	- 0350 1 Reserve Equipment 2 National Guard Equipment
Defense Production Activity Purchase	- 0360 1 Defense Production Activity Purchases
Chemical Agents and Munitions Destruction	- 0390 1 Chemical Agents and Munitions Destruction—O&M 2 Chemical Agents and Munitions Destruction—RDT&E 3 Chemical Agents and Munitions Destruction—Procurement
Rapid Acquisition Fund	-2095 1 Rapid Acquisition Fund

**RESEARCH, DEVELOPMENT, TEST, AND EVALUATION  
(RDT&E) APPROPRIATIONS  
(Account Numbers)**

<u>Appropriation</u>	<u>Account Number</u>
RDT&E, Army	21 – 2040
RDT&E, Navy	17 – 1319
RDT&E, Air Force	57 – 3600
RDT&E, Defense-wide	97 – 0400
Development T&E, Defense	97 – 0450
Operational T&E, Defense	97 – 0460

**RDT&E APPROPRIATIONS  
(Relationship Between MFP 6 R&D Categories and  
RDT&E Appropriations Budget Activities)**

<b>MFP 6 R&amp;D Category</b>	<b>RDT&amp;E Budget Activity</b>	<b>RDT&amp;E Budget Activity Title</b>
6.1	BA 1	Basic Research
6.2	BA 2	Applied Research
6.3	BA 3	Advanced Technology Development
6.4	BA 4	Advanced Component Development and Prototypes
6.5	BA 5	System Development and Demonstration
6.6	BA 6	RDT&E Management Support
---	BA 7	Operational System Development

<b>LEGEND:</b>	
BA—Budget Activity	R&D—Research and Development
MFP—Major Force Program	T&E—Test and Evaluation

**\*NOTE:** Although similar, titles of the Major Force Program (MFP) 6 categories (which are not shown above) are not exactly the same as titles of the RDT&E Appropriation Budget Activities. In addition, the “Operational System Development” Budget Activity for RDT&E BA 7 is not considered MFP 6. While correctly funded with RDT&E dollars, these efforts do not fall under a MFP 6 Category; rather, for MFP purposes, the efforts are considered part of the MFP that the fielded operational system falls within. Congress calls BA 4, Demonstration and Validation, and calls BA 5, Engineering and Manufacturing Development.

## SAMPLE NAVY APPROPRIATIONS AND BUDGET ACTIVITIES

MFP 6 R&D Category	RDT&E Budget Activity (BA) Number and Title	Below Threshold Reprogramming Rules Max In*      Max Out*		Years Available for Obligation Purposes	Funding Policy
		<small>(At Prog. Element Level)</small>			
6.1	BA 1 Basic Research	Lesser of	Lesser of	2	Incremental
6.2	BA 2 Applied Research	+ \$10M or	- \$10M or	↓	↓
6.3	BA 3 Advanced Tech. Development	+20% of	-20% of		
6.4	BA 4 Adv. Comp. Dev. and Prototypes	amount	amount		
6.5	BA 5 System Devel. and Demo.	appropriated	appropriated		
6.6	BA 6 RDT&E Management Support (T&E Ranges) (Civilian Salaries)	↓	↓		
	BA 7 Operational Systems Devel. (Post-Production)	↓	↓		
		↓	↓		
Procurement Budget Activity	Budget Activity Description	Below Threshold Reprogramming Rules Max In      Max Out		Years Available for Obligation Purposes	Funding Policy
		<small>(At Line Item Level)</small>			
<b>PROCUREMENT (Proc.)</b>					
SCN-1	Not Used	Lesser of	Lesser of	5	Full
SCN-2	Ship Conversion—Other Warships	+ \$20M or	- \$20M or	↓	↓
SCN-3	Ship Conversion—Amphibious Ships	+20% of	-20% of		
SCN-4	Not Used	amount	amount		
SCN-5	Ship Conversion—Auxiliaries, Craft, and Prior-Year Program Costs	appropriated	appropriated		
WPN-1	Weapons Proc—Ballistic Missiles	↓	↓		
WPN-2	Weapons Proc—Other Missiles	↓	↓		
WPN-3	Weapons Proc—Torpedos and Equipment	↓	↓		
WPN-4	Weapons Proc—Other Weapons	↓	↓		
WPN-5	Not Used	↓	↓		
WPN-6	Weapons Proc—Spares and Repair Parts	↓	↓		
OPN-1	Other Proc—Ship Support Equipment (SE)	↓	↓		
OPN-2	Other Proc—Comm./Electronics Equip.	↓	↓		
OPN-3	Other Proc—Aviation SE	↓	↓		
OPN-4	Other Proc—Ordnance SE	↓	↓		
OPN-5	Other Proc—Civil Engineering SE	↓	↓		
OPN-6	Other Proc—Supply SE	↓	↓		
OPN-7	Other Proc—Pers. and Command SE	↓	↓		
OPN-8	Other Proc—Spares and Repair Parts	↓	↓		
APN-1	Aircraft Proc—Combat Aircraft	↓	↓		
APN-2	Aircraft Proc—Airlift Aircraft	↓	↓		
APN-3	Aircraft Proc—Trainer Aircraft	↓	↓		
APN-4	Aircraft Proc—Other Aircraft	↓	↓		
APN-5	Aircraft Proc—Modifications of Aircraft	↓	↓		
APN-6	Aircraft Proc—Aircraft Spares and Repair Parts	↓	↓		
APN-7	Aircraft Proc—Aircraft SE and Facilities	↓	↓		
Other Appropriations / Titles		Max In	Max Out	Years Available for Obligation Purposes	Funding Policy
<b>O&amp;M, N</b>	Operations and Maintenance	\$15M	No Congressional Restriction	1	Annual
<b>MILPER, N</b>	Military Personnel	\$10M	No Congressional Restriction	1	Annual
<b>MILCON, N</b>	Military Construction	Lesser of + \$2.0M or +25% Appropriated	No Congressional Restriction	5	Full

\*Below Threshold Reprogramming (BTR) amount limits are cumulative over entire period of time the specific fiscal year appropriation is available for obligation purposes (i.e., 1, 2, 3, or 5 years).

\*\*Reference Source: DoD FMR, Volume 3, Chapter 6, a/o September 2010.

## APPROPRIATION LIFE

	YEARS											
	1	2	3	4	5	6	7	8	9	10	11	
O&M	■	■	■	■	■	■	■	■	■	■	■	■
RDT&E	■	■	■	■	■	■	■	■	■	■	■	■
PROCUREMENT	■	■	■	■	■	■	■	■	■	■	■	■
SHIPS	■	■	■	■	■	■	■	■	■	■	■	■
MILCON	■	■	■	■	■	■	■	■	■	■	■	■
MILPERS	■	■	■	■	■	■	■	■	■	■	■	■

■ **Current Period:** Available for new obligations, obligation adjustments, expenditures, and outlays

■ **Expired Period:** Available for obligation adjustments, expenditures, and outlays

■ **Cancelled:** Unavailable for obligations, obligation adjustments, expenditures, and outlays

## BELOW THRESHOLD REPROGRAMMING ACTIONS

Amounts are Cumulative Over Entire Period of Obligation Availability

APPN	MAX INTO	MAX OUT	LEVEL OF CONTROL	OBLIGATION AVAILABLE
RDT&E	Lesser of +\$10M or +20%	Lesser of -\$10M or -20%	Program Element	2 Years
PROC	Lesser of +\$20M or +20%	Lesser of -\$20M or -20%	Line Item	3 Years (Shipbuilding and Conversion, Navy: 5 Years)
O&M	+\$15M	None, Unless Otherwise Specified	Budget Activity (BA) Some BA 1 Sub-activity Limitations on Decreases (Operating Forces)	1 Year
MILPERS	+\$10M	No Specific Congressional Restriction	Budget Activity	1 Year
MILCON	Lesser of +\$2M or +25%	No Specific Congressional Restriction	Project	5 Years

Reference Sources: (1) USD (C) Memo, SUBJECT: FY 2006 Below Threshold Reprogramming Authority Policy, 10 Feb 2006, (2) USD (C) Memo, SUBJECT: DD 1414, Base for Reprogramming Actions, 5 Jan 2010

## LIFE CYCLE COST COMPOSITION

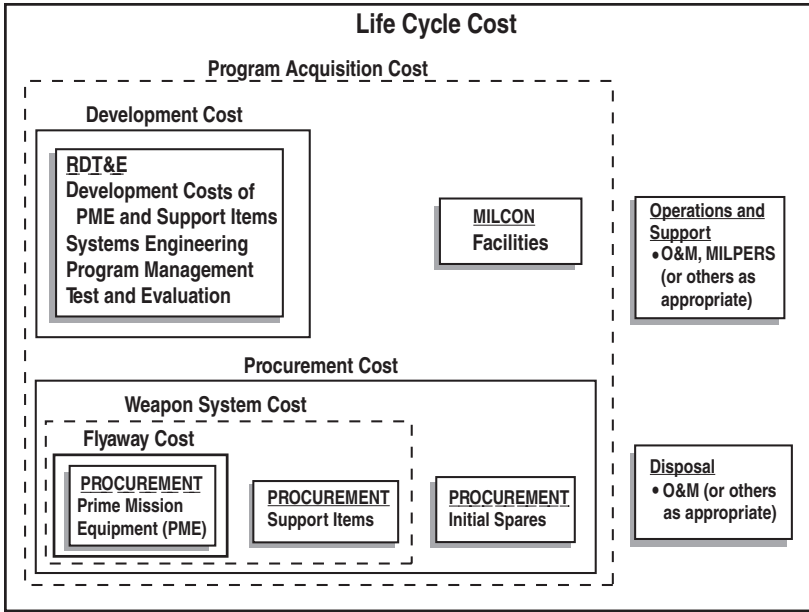

## PRODUCT IMPROVEMENTS Funding Decision Tree

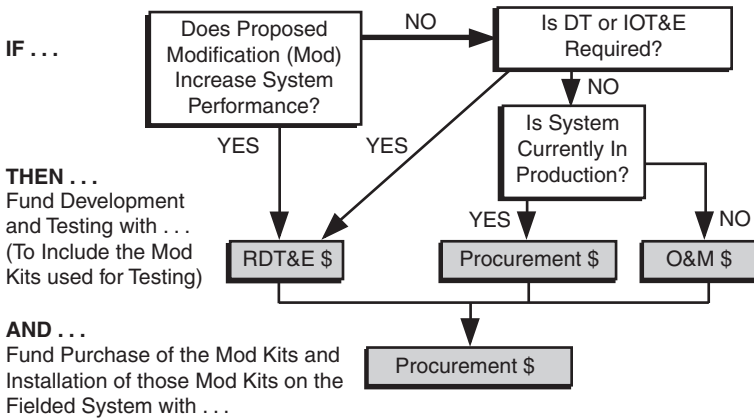

## COST ESTIMATING

### *Estimate Methods*    *Comments*

Analogy	Comparison to <i>one</i> similar existing system; based on judgments. Little or no data available; relatively quick, easy, flexible. Used in early phases (e.g., Material Solution Analysis and Tech. Dev.)
Parametric	Comparison to <i>many</i> similar existing systems; based on statistical analysis. Determine primary cost drivers and establish Cost Estimating Relationships (CERs). Used in early to mid-phases (e.g., Material Solution Analysis, Tech. Dev., and Engr. and Manufacturing Dev.)
Engineering or “Bottoms-Up”	Summation of “all” individual items in the system. Uses Work Breakdown Structure (WBS) for estimating purposes. Used in mid-phases (e.g., Engineering and Manufacturing Development)
Extrapolation	Comparison to historical cost of <i>same</i> system. Based on extrapolation from actuals. Uses Learning Curve Theory. Used in late phases (e.g., Production and Operations/Support)

### *Guidelines*

1. Make sure cost data are relevant and homogeneous. Caution: Watch out for historical data in times of change. Prior actuals may include uncompensated overtime or were priced as a “buy-in.”
2. Focus on cost drivers.
3. Test sensitivities and data relationships.

## COST ESTIMATING RELATIONSHIPS (CER)— PARAMETRIC

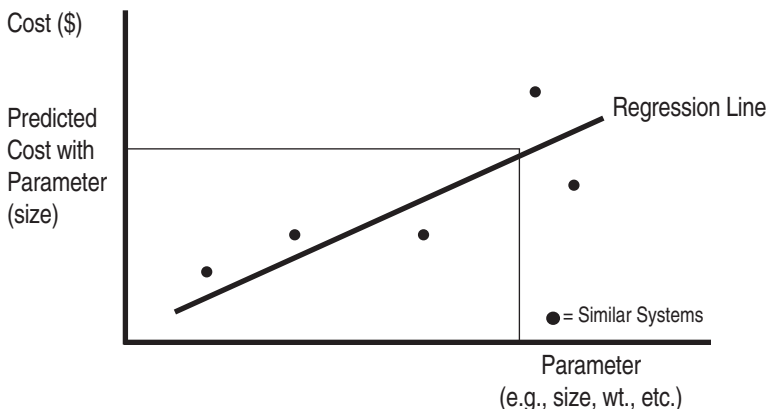

## COST ESTIMATING REQUIREMENTS

	ACAT IC and ID (MDAP)	ACAT IAM and IAC (MAIS)
POE	Program initiation & all subsequent milestones, including FRP DR	Program initiation & all subsequent milestones
CARD	Program initiation & all subsequent milestones including FRP DR <ul style="list-style-type: none"> <li>• Draft: 180 days prior to OIPT</li> <li>• Final: 45 days prior to OIPT</li> </ul>	Program initiation & whenever Economic Analysis is required <ul style="list-style-type: none"> <li>• Draft: 180 days prior to OIPT</li> <li>• Final: 45 days prior to OIPT</li> </ul>
CCE	MS A and all subsequent milestones including FRP DR	MS A and whenever an Economic Analysis including is required
ICE	Required by law for all MDAP programs * <ul style="list-style-type: none"> <li>• Prepared by OSD CAPE for ACAT ID, and ACAT IC at discretion of USD (AT&amp;L)</li> <li>• Prepared by component cost agency (AFCAA,DASA-CE, NCCA) for ACAT IC (if no CAPE estimate)</li> <li>• In advance of any certification under Title 10, U.S.C., Section 2366a (MS A) and Section 2366b (MS B)</li> <li>• In advance of any decision to enter low-rate initial production (LRIP) (MS C) or full-rate production (FRP DR)</li> <li>• In advance of any certification of MDAPs that experience critical cost growth (Title 10, U.S.C., Sec 2433a)</li> <li>• In advance of any report of Critical Program Changes for MAIS (Title 10, U.S.C., Sec 2445c(f))</li> </ul>	

\*ICE statutory requirement (Title 10, US Code, Sec 2434) and P.L. 111-23, May 22, 2009

Source: DoDI5000.02, December 2008 and Weapon Systems Acquisition Reform Act of 2009

**ACAT II & ACAT III: POE (and, at MDA discretion, an independent cost estimate prepared by the component cost agency) at program initiation and all subsequent milestones**

**LEGEND:**

AFCAA—Air Force Cost Analysis Agency  
 CAE—Component Acquisition Executive  
 CAPE—Cost Assessment & Program Evaluation  
 CARD—Cost Analysis Requirements Description  
 CCE—Component Cost Estimate  
 DASA-CE—DepAsst Sec of Army (Cost & Economics)  
 FRP DR—Full Rate Production Decision Review  
 ICE—Independent Cost Estimate

MAIS—Major Automated Information System  
 MDA—Milestone Decision Authority  
 MDAP—Major Defense Acquisition Program  
 NCCA—Naval Center for Cost Analysis  
 OIPT—Overarching Integrated Product Team  
 POE—Program Office Estimate  
 USD(AT&L)—Under Secretary of Defense (Acquisition, Technology, & Logistics)

## PROGRAM COST AND SCHEDULE BREACH PARAMETERS

Applicable to Major Defense Acquisition Programs (MDAPs)			
	<b>SAR</b> <i>(Title 10, U.S.C., Sec. 2432)</i>	<b>Unit Cost Report (UCR)</b> <i>(Title 10, U.S.C., Sec 2433) (Nunn-McCurdy)</i>	<b>APB</b> <i>(Title 10, U.S.C., Sec 2435)</i>
<b>Schedule Milestones</b>	6 month slip from previous SAR	N/A	Slip beyond threshold date * Default threshold = objective plus 6 months; MDA discretion
<b>Cost</b>	15/30% PAUC Growth (Current/Original)  15/30% APUC Growth (Current/Original)	15/30% PAUC Growth (Current/Original)  15/30% APUC Growth (Current/Original)	15/30% PAUC Growth 15/30% APUC Growth (Current/Original)  * RDT&E Growth * Procurement Growth * MILCON or O&M Growth * 10% default; MDA discretion
<b>Reports Required if Breach Occurs</b>	Quarterly SAR	Quarterly/Exception DAES Service notifies Congress ( $\leq 15/30\%$ ) SecDef Certification ( $\geq 25/50\%$ )	Program Deviation Report (PM notifies MDA)

**ACAT II and III: 15/30% PAUC/APUC APB breach parameters are N/A; actual breach parameters at MDA discretion**

<p><b>LEGEND :</b></p> <ul style="list-style-type: none"> <li>APB—Acquisition Program Baseline</li> <li>APUC—Average Procurement Unit Cost</li> <li>DAES—Defense Acquisition Executive Summary</li> <li>Dir, CAPE—Director, Cost Assessment &amp; Program Evaluation</li> <li>PAUC—Program Acquisition Unit Cost</li> <li>SAR—Selected Acquisition Report</li> </ul>	<p><b>Critical Cost Growth (APB/SAR/UCR)</b></p> <ul style="list-style-type: none"> <li>PAUC or APUC increases of 25% of current baseline or 50% of original baseline requires Sec Def certification to Congress:</li> <li>— Essential to National Defense</li> <li>— No acceptable alternative capability at less cost</li> <li>— New estimates are reasonable per Dir, CAPE</li> <li>— Program cost growth higher priority than programs providing offsets</li> <li>— Management structure adequate to control costs</li> </ul>
<p><b>Significant Cost Growth (APB/SAR/UCR)</b></p> <p>PAUC or APUC increases of 15% of current baseline or 30% of original baseline is "reportable" to Congress.</p>	

## EARNED VALUE MANAGEMENT “GOLD CARD”

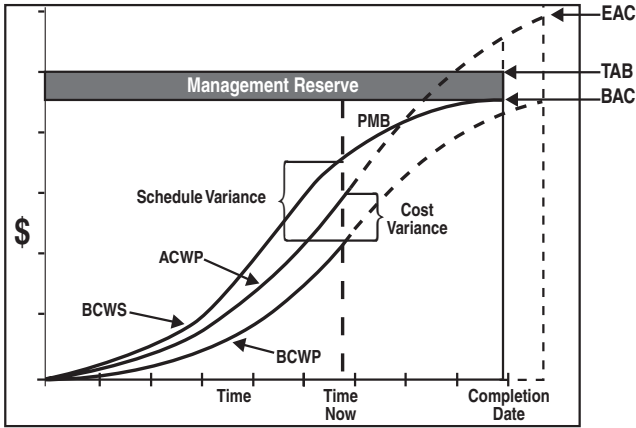

**VARIANCES** Favorable is Positive, Unfavorable is Negative

Cost Variance  $CV = BCWP - ACWP$   $CV \% = (CV / BCWP) * 100$

Schedule Variance  $SV = BCWP - BCWS$   $SV \% = (SV / BCWS) * 100$

Variance at Completion  $VAC = BAC - EAC$

### OVERALL STATUS

% Schedule =  $(BCWS_{CUM} / BAC) * 100$

% Complete =  $(BCWP_{CUM} / BAC) * 100$

% Spent =  $(ACWP_{CUM} / BAC) * 100$

### DoD TRIPWIRE METRICS (TW)

<sup>(TW)</sup> Cost Efficiency  $CPI = BCWP / ACWP$  Favorable is  $> 1.0$ , Unfavorable is  $< 1.0$

<sup>(TW)</sup> Schedule Efficiency  $SPI = BCWP / BCWS$  Favorable is  $> 1.0$ , Unfavorable is  $< 1.0$

### <sup>(TW)</sup> BASELINE EXECUTION INDEX (BEI) (Schedule Metric)

BEI = Tasks with Actual Finish Date / (# of Baseline Tasks Scheduled to Finish Prior to Status Date + Tasks Missing Baseline Start or Finish Date)

### <sup>(TW)</sup> CRITICAL PATH LENGTH INDEX (CPLI) (Schedule Metric)

$CPLI = (CP\ Length_{(Time\ Now\ to\ Contract\ End)} + Total\ Float_{(To\ Contract\ End\ Baseline\ Finish)}) / CP\ Length$

**HIT/MISS** (Month's Task Completed ON or AHEAD/ Month's Tasks Scheduled to Complete)

### TO COMPLETE PERFORMANCE INDEX (TCPI)<sup>#§</sup>

$TCPI_{EAC} = Work\ Remaining / Cost\ Remaining = (BAC - BCWP_{CUM}) / (EAC - ACWP_{CUM})$

**ESTIMATE AT COMPLETION<sup>#</sup> (EAC)** (Actuals to Date + [(Remaining Work)/(Performance Factor)])

$EAC_{CPI} = ACWP_{CUM} + [(BAC - BCWP_{CUM}) / CPI_{CUM}] = BAC / CPI_{CUM}$

$EAC_{Composite} = ACWP_{CUM} + [(BAC - BCWP_{CUM}) / (CPI_{CUM} * SPI_{CUM})]$

<sup>#</sup>To determine a contract level TCPI or EAC, you may replace BAC with TAB.

<sup>§</sup>To determine the TCPI <sub>BAC or LRE</sub>, substitute BAC or LRE for EAC.

For more information, go to the EVM Home Page at <https://acc.dau.mil/evm>, e-mail EVM at EVM.dau@dau.mil, or call 703-805-5259 (DSN 655).

## EARNED VALUE MANAGEMENT “GOLD CARD”

(Continued)

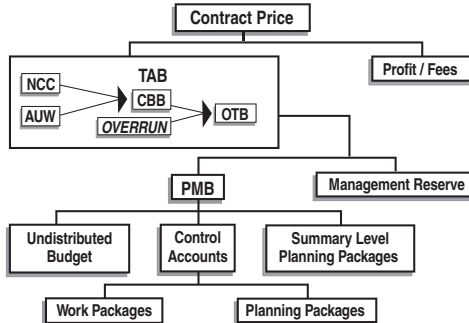

### TERMINOLOGY

ACWP	Actual Cost of Work Performed	Cost actually incurred in accomplishing work performed = ACTUAL COST
AUW	Authorized Unpriced Work	Work contractually approved, but not yet negotiated /defined
BAC	Budget At Completion	Total budget for total contract thru any given level
BCWP	Budgeted Cost for Work Perf.	Value of completed work in terms of the work's assigned budget = EARNED VALUE
BCWS	Budgeted Cost for Work Sched.	Time-phase Budget Plan for work currently scheduled = PLANNED VALUE
CA	Control Account	Lowest CWBS element assigned to a single focal point to plan and control scope/schedule/budget
CBB	Contract Budget Base	Sum of NCC and AUW
EAC	Estimate At Completion	Estimate of total Cost for total contract thru any given level; may be generated by Ktr, PMO, DCMA, etc. = $EAC_{KTR/PMO/DCMA}$
LRE	Latest Revised Estimate	Ktr's EAC or $EAC_{KTR}$
MR	Management Reserve	Budget withheld by Ktr PM for unknowns/risk management
NCC	Negotiated Contract Cost	Contract Price minus profit / fee(s)
OTB	Over Target Baseline	Sum of CBB and recognized overrun
PAC	Price At Completion	NCC Plus Profit or Fee(s)
PMB	Perf. Measurement Baseline	Contract time-phased budget plan
PP	Planning Package	Far-term CA activities not yet defined into WPs
SLPP	Summary Level Plan. Package	Far-term activities not yet defined into CAs
TAB	Total Allocated Budget	Sum of all budgets for work on contract = NCC, CBB, or OTB
TCPI	To Complete Performance Index	Efficiency needed from 'time now' to achieve an BAC, EAC, or LRE
UB	Undistributed Budget	Broadly defined activities not yet distributed to CAs
WP	Work Package	Near-term, detail-planned activities within a CA

**EVM POLICY:** DoDI 5000.02, Table E4.T5. EVMS in accordance with ANSI/EIA-748 is required for cost or incentive contracts, subcontracts, intra-government work agreements, and other agreements valued  $\geq$  \$20M (Then-Yr \$). EVMS contracts  $\geq$  \$50M (TY \$) require that the EVM system be formally validated by the cognizant contracting officer. Additional guidance is in the *Defense Acquisition Guidebook* and the *Earned Value Management Implementation Guide* (EVMIG). EVMS is discouraged on Firm-Fixed Price & Time & Material Contracts, & LOE activities regardless of cost.

### EVM CONTRACTING REQUIREMENTS:

FAR EVM Clauses Non-DoD	— 52.234-2 for Solicitation (Pre-Award IBR) or 52.234-3 (Post Award IBR)
	— 52.234-4 Solicitation & Contract
DoD Use DFAR Clauses ( $\geq$ \$20M)	— 252.234-7001 "Notice of EVMS" for solicitations
	— 252.234-7002 "EVMS" for solicitations & contracts
Contract Performance Report	— DI-MGMT-81466A* 5 Formats (WBS, Organization, Baseline, Staffing & Explanation)
Integrated Master Schedule	— DI-MGMT-81650* (Mandatory for DoD EVMS contracts)
Integrated Baseline Review (IBR)	— Mandatory for all EVMS contracts

\* See the EVMIG for CPR and IMS tailoring guidance.

## CONTRACTING—COMPONENTS OF CONTRACT PRICE

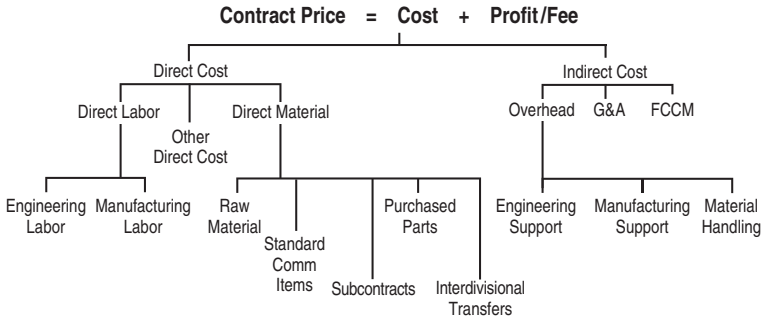

### TYPICAL CONTRACT TYPE BY PHASE

MSA	TD	EMD/ISD	EMD/SCMPD	PROD
CPFF, FFP	CPFF, FFP	FPI(F), CPFF, CPIF	CPIF, CPAF	FPI(F), FFP

**LEGEND:**

- |  |   |
|--|---|
| <p>AF — Award Fee<br/>                 CPAF — Cost Plus Award Fee<br/>                 CPFF — Cost Plus Fixed Fee<br/>                 CPIF — Cost Plus Incentive Fee<br/>                 CR — Cost Reimbursement<br/>                 EMD — Engineering and Manufacturing Demonstration<br/>                 FAR/DFARS — Federal Acquisition Regulation/Defense FAR Supplement<br/>                 FCCM — Facilities Capital Cost of Monies<br/>                 FFP — Firm Fixed Price</p> | <p>FPI(F) — Fixed Price Incentive (Firm Target)<br/>                 G&amp;A — General and Administrative (Expense)<br/>                 ISD — Integrated System Design<br/>                 MSA — Materiel Solution Analysis<br/>                 ODC — Other Direct Cost<br/>                 PROD — Production<br/>                 R&amp;D — Research and Development<br/>                 SCMPD — System Capability and Manufacturing Process Demonstration<br/>                 TD — Technology Development</p> |
|--|---|

## TYPES OF CONTRACTS

**Cost Family** — Appropriate when product not well defined; high risk; contractor provides best efforts; government pays all allowable costs. Fee varies by type.

**Cost Plus Fixed Fee** — Fee same regardless of actual cost outcome.

**Cost Plus Incentive Fee** — Actual fee earned computed by applying share ratio to over/under run, subject to min/max fee limits.

**Fixed Price Family** — Product well defined, low risk; contractor must deliver product.

**Firm Fixed Price** — Price fixed regardless of actual cost incurred.

**Fixed Price Incentive (Firm Target)** — Final price computed by applying share ratio to over/underrun, subject to ceiling price limitation.

**Award Fee** — Either stand-alone Cost Plus Award Fee or combined with cost or fixed price types. Award Fee unilaterally determined by government based on subjective evaluation of contractor's performance.

**Fee Limits: Cost Plus Fixed Fee** — Fee limited to 15% for R&D; 10% for production and services. No statutory or FAR/DFARS regulatory limitation on other contract types.

## CONTRACT TYPE FEATURES

	<u>FIXED PRICE</u>	<u>COST REIMBURSEMENT</u>
Promise	Delivery	Best Efforts
Contractor Risk	High	Low
Cash Flow	Delivery	As Incurred
Progress Payments %	75/90/95	N/A
Administration	Low	High
Fee Limit %	None	15/10/6 on CPFF

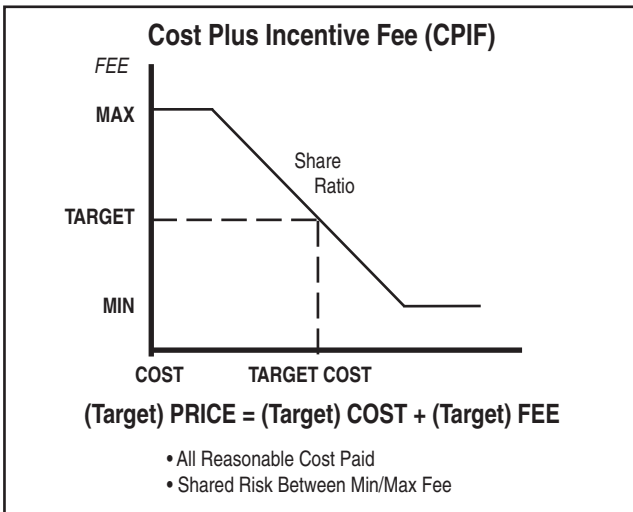
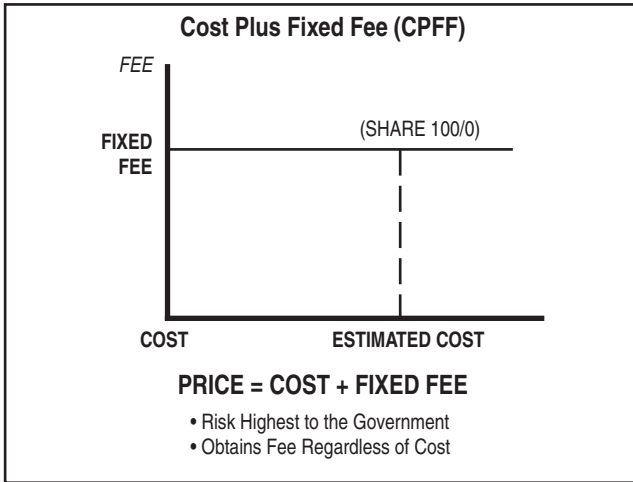

## CONTRACT TYPE FEATURES

(Continued)

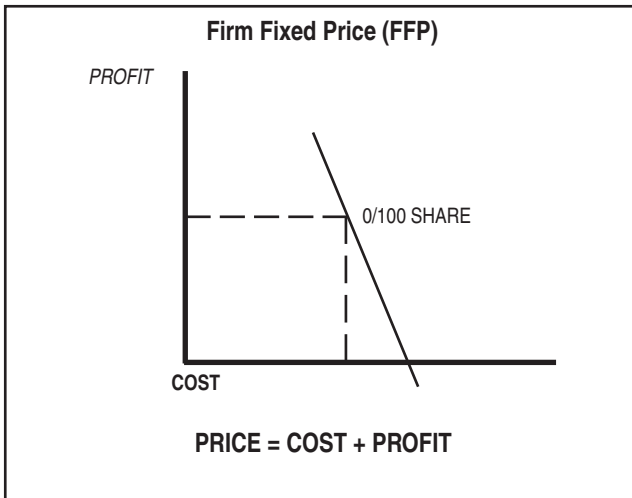
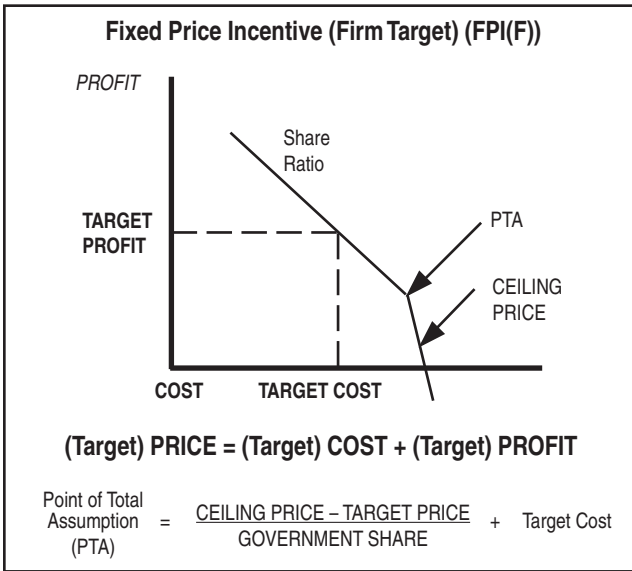

## PRE-SOLICITATION PROCESS

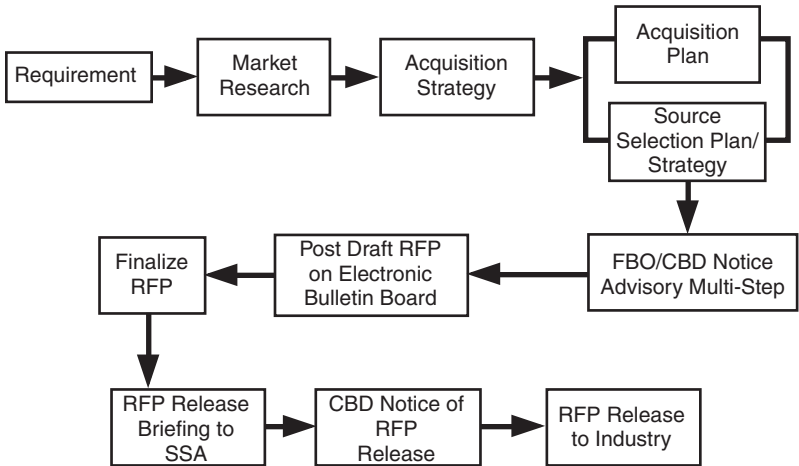

## POST-SOLICITATION PROCESS

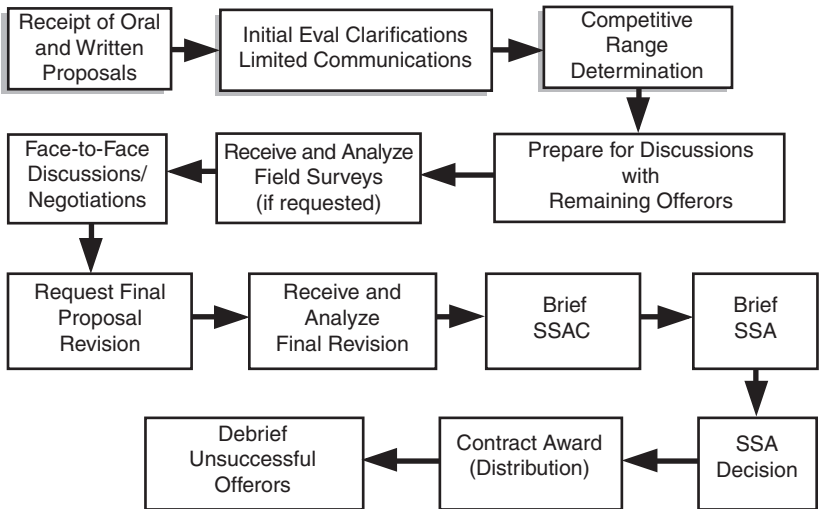

**LEGEND:**

FBO/CBD—FedBizOps/Commerce Business Daily  
RFP—Request for Proposal

SSA—Source Selection Authority  
SSAC—Source Selection Advisory Council

## OTHER WAYS TO BUY

- **GSA Multiple Award Schedules (MAS)**
  - General Services Administration contracts for both products and services—available to all agencies.
- **Government-Wide Agency Contracts (GWACs)**
  - Similar to MAS, but more restricted in products and services available.
- **Indefinite Delivery/Indefinite Quantity Contracts**
  - Task orders (services) and delivery orders (products) issued under omnibus umbrella contract.
- **Other Transactions (OT)**
  - **Defined:** Vehicles used for basic, applied, and advanced research projects and prototype development. OTs are not contracts, grants, or cooperative agreements.
  - **Objective:** Attract commercial companies and consortia that historically have not done business with the Department of Defense because of statutory and/or regulatory requirements. OTs are not subject to the Federal Acquisition Regulation. *Designed to increase DoD access to dual-use technologies.*
  - **Research Projects:**
    - ◆ Where practical, government cost share should not exceed cost share of other parties.
    - ◆ Use OT when standard contract, grant, or cooperative agreement is not appropriate.
  - **Prototype Projects:**
    - ◆ Must be directly relevant to weapons or weapon systems proposed to be acquired or developed by DoD.
  - **Constraints:**
    - ◆ At least one nontraditional contractor participating.
    - ◆ If no nontraditional contractor participates, 1/3 of cost paid by parties other than federal government or senior procurement executive justifies transaction.
  - **OT Guide for Prototype Projects, January 2001.**

## CONTRACTOR PROFITABILITY RATIOS

The basic concept of profitability ratios is to measure net income against revenue or against the investment required to produce it. There are three principal profitability ratios with which you should be familiar. They are:

1. **Return on Sales**, which shows what percentage of dollars are left after the company has paid for all costs, interest, and taxes. It is expressed as:

$$\text{Return on Sales} = \frac{\text{Net Income}}{\text{Sales}}$$

2. **Return on Total Assets**, which looks at the efficiency with which management has used its resources, the company's assets, to generate income. It is computed as:

$$\text{ROA} = \frac{\text{Net Income}}{\text{Total Assets}}$$

As noted, **Return on Assets** addresses how well management utilizes the assets of the firm in generating income. The ROA formula reflects the combined result of Return on Sales and the total asset turnover ratio (total sales/total assets), broken down as follows:

$$\text{ROA} = \frac{\text{Net Income}}{\text{Total Sales}} \times \frac{\text{Total Sales}}{\text{Total Assets}}$$

3. **Return on Stockholders' Equity** measures the rate of return on the owners' investment—their equity in the company. This is also known as **Return on Equity**:

$$\text{ROE} = \frac{\text{Net Income}}{\text{Stockholders' Equity}}$$

ROE can also be broken into two components: return on assets and financial leverage (a ratio reflecting the relationship of creditor to owner financing—expressed as total assets/stockholders equity). This is shown by:

$$\text{ROE} = \frac{\text{Net Income}}{\text{Total Assets}} \times \frac{\text{Total Assets}}{\text{Stockholders' Equity}}$$

These profitability ratios give three different viewpoints concerning the "bottom line" on the income statement—how much net profit is being made on each sale, how much is being made for the assets that are employed, and how much is being made for the company owners. Contractor profitability ratios for the aerospace/defense industry for the period of 1980 to date are shown on page 38.

From an owner's perspective, another profitability ratio you may be aware of is **Earnings Per Share**:

$$\text{EPS} = \frac{\text{Net Income}}{\text{Number of Shares of Common Stock Outstanding}}$$

**LEGEND:**

EPS—Earnings Per Share

ROA—Return on Assets

ROE—Return on Equity

## AEROSPACE/DEFENSE INDUSTRY CONTRACTOR PROFITABILITY RATIOS

### Aerospace/Defense Industry Contractor Profitability Ratios

	Return On Sales (NI/S)	Asset Turnover (S/TA)	Return On Assets (NI/TA)	Financial Leverage (TA/SE)	Return On Equity (NI/SE)
1980	4.3	1.21	5.2	3.08	16.0
1981	4.4	1.18	5.2	3.06	16.0
1982	3.3	1.12	3.7	3.24	12.0
1983	3.5	1.17	4.1	2.98	12.1
1984	4.1	1.15	4.7	3.00	14.1
1985	3.1	1.13	3.6	3.17	11.1
1986	2.8	1.07	3.1	3.13	9.4
1987	4.1	1.07	4.4	3.32	14.6
1988	4.3	1.02	4.4	3.39	14.9
1989	3.3	1.00	3.3	3.24	10.7
1990	3.4	1.00	3.4	3.38	11.5
1991	1.8	1.06	1.9	3.21	6.1
1992	-1.4	0.86	-1.2	4.33	-5.2
1993	3.6	0.97	3.5	3.80	13.2
1994	4.7	0.92	4.3	3.44	14.8
1995	3.8	0.92	3.5	3.17	11.1
1996	5.6	0.91	5.1	3.35	17.1
1997	5.2	0.92	4.8	3.60	17.3
1998	5.0	0.96	4.8	3.73	18.0
1999	6.5	0.95	6.2	3.52	21.8
2000	4.7	0.91	4.3	3.30	14.2
2001	3.9	0.92	3.6	3.22	11.6
2002	4.1	0.90	3.7	3.16	11.7
2003	3.1	0.84	2.6	3.81	9.9
<b>AVERAGE</b>	3.8	1.0	3.8	3.4	12.7

Source: Aerospace Industries Association.

**LEGEND:**

NI/S—Net Income/Sales

NI/SE—Net Income/Stockholders' Equity

NI/TA—Net Income/Total Assets

S/TA—Sales/Total Assets

TA/SE—Total Assets/Stockholders' Equity

**LOCKHEED MARTIN CORP.—DUPONT FORMULA ANALYSIS (AN EXAMPLE)**

Fiscal Year	Return on Sales %	Total Asset Turnover	Return on Assets %	Financial Leverage	Return on Equity %
1999	1.53%	0.826	1.26%	4.757	6.01%
2000	-2.11%	0.807	-1.71%	4.249	7.25%
2001	-4.36%	0.866	-3.77%	4.301	-16.23%
2002	1.88%	0.985	1.85%	4.600	8.53%
2003	3.31%	1.216	4.02%	3.874	15.59%

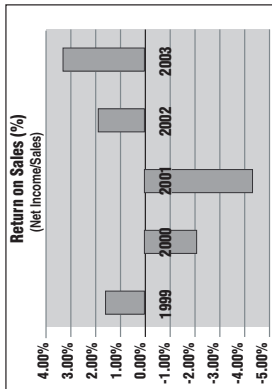

**X**

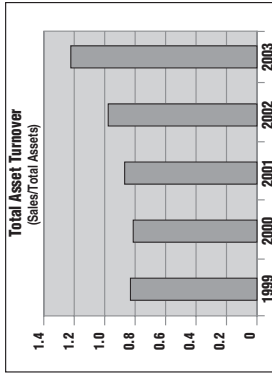

**=**

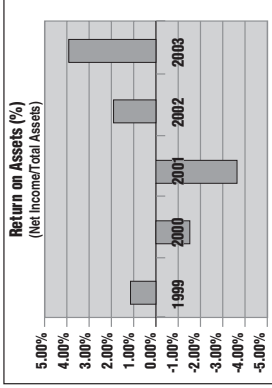

**X**

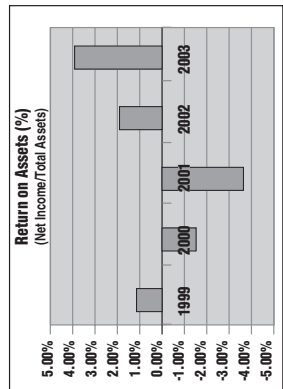

**=**

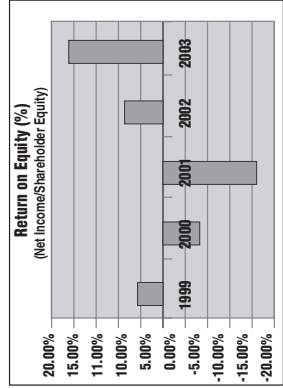
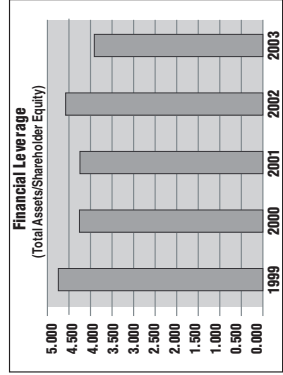

### CASH CYCLE

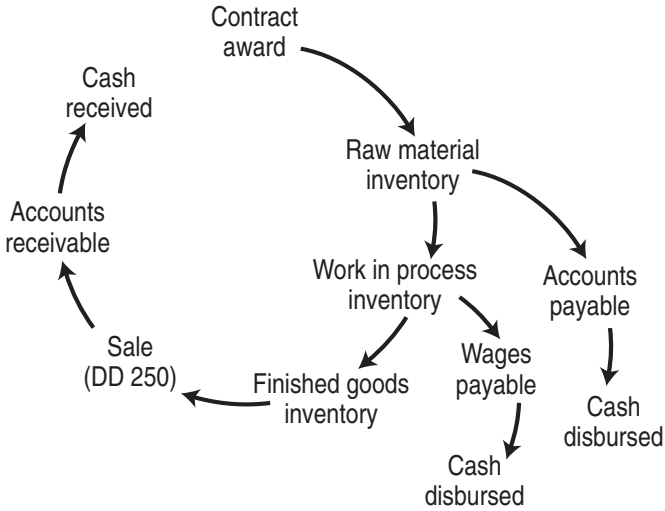

### CONTRACTOR FINANCING AND PAYMENTS

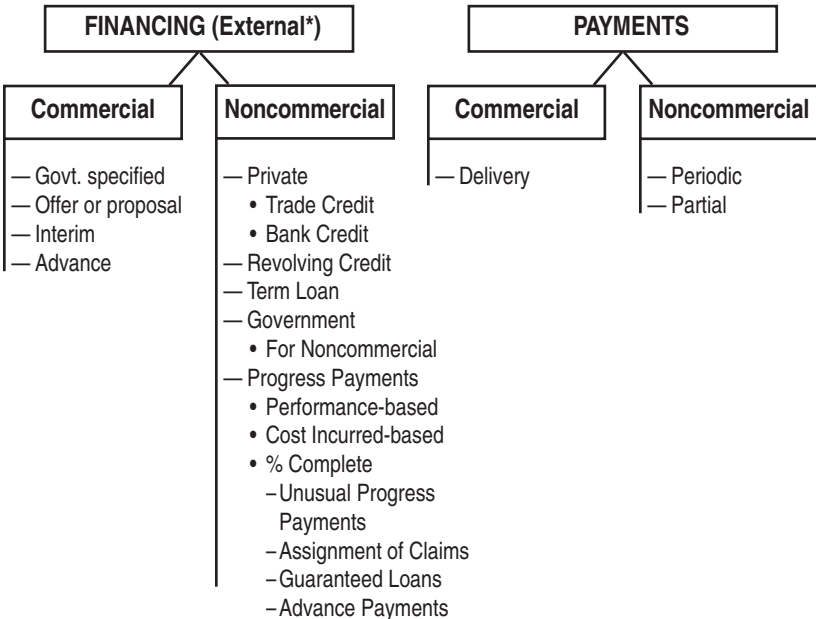

\*Internal Contractor Financing — Retained Earnings

## DIRECT AND INDIRECT COSTS

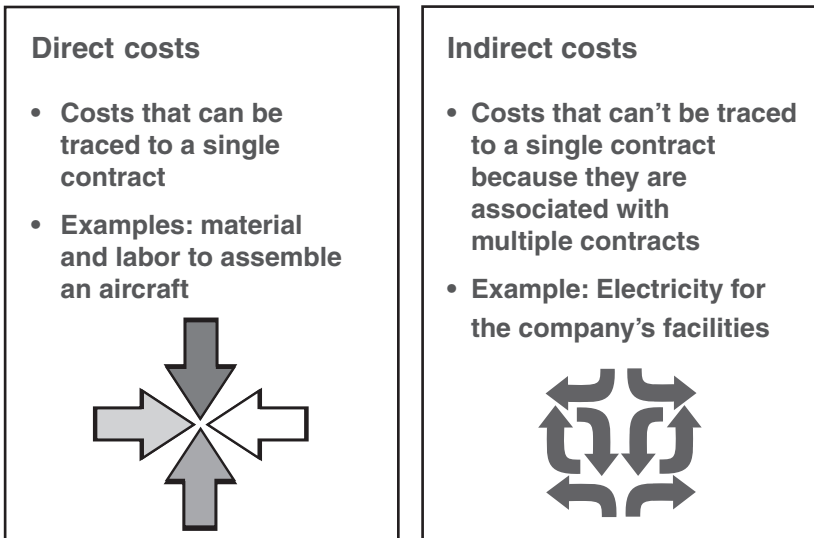

## ASSIGNING INDIRECT COSTS

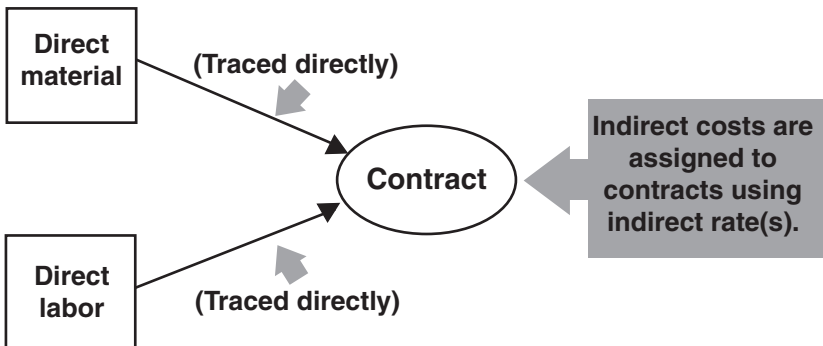

Note: See DAU *Indirect-Cost Management Guide* at [www.dau.mil/pubs/gdbks/icmguide.asp](http://www.dau.mil/pubs/gdbks/icmguide.asp).

### Calculation of Indirect Rates

$$\text{INDIRECT RATE} = \frac{\text{Indirect Cost Pool}}{\text{Allocation Base}}$$

## LIFE CYCLE OF INDIRECT COST RATES

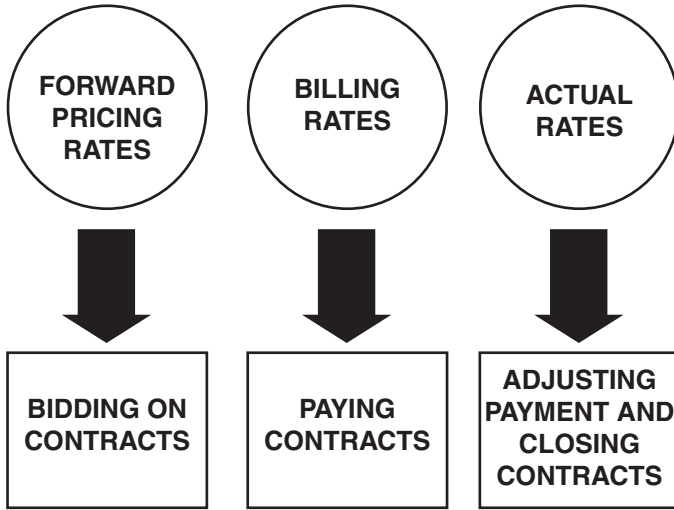

### CONTRACTOR'S COST PROPOSAL

#### EXAMPLE

Direct material	\$ 40,000
Material handling 10%	4,000
Direct engineering labor	6,000
Engineering overhead 100%	6,000
Direct manufacturing labor	12,000
Manufacturing overhead 150%	18,000
Other direct costs	<u>6,000</u>
Subtotal	92,000
General and administrative 25%	<u>23,000</u>
Total cost	115,000
Profit 15%	17,250
Cost of money for facilities capital	<u>1,500</u>
<b>Price</b>	<u><u>\$133,750</u></u>

## CONTRACTOR BUSINESS PLANNING PROCESS OUTPUTS

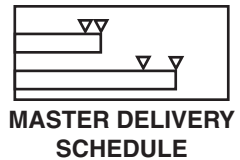
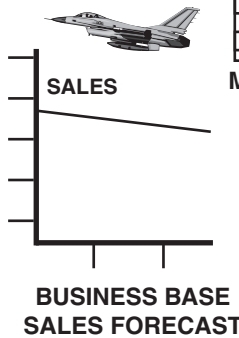
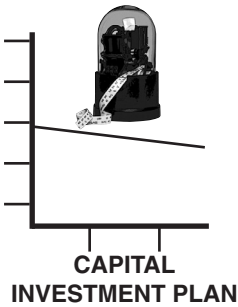
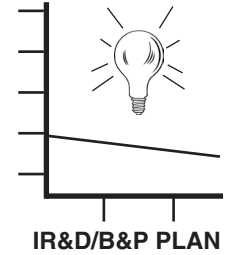
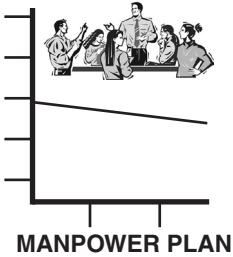
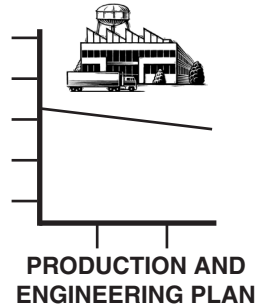
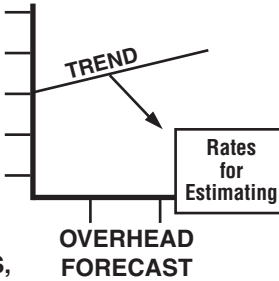

**LEGEND:**  
B&P—Bid of Proposal  
IR&D—Independent Research and Development

## LIFE CYCLE LOGISTICS

The planning, development, implementation, and management of a comprehensive, affordable, and effective product support strategy, within Total Life Cycle Systems Management. Life Cycle Logistics encompasses the entire system's life cycle, including acquisition (design, develop, test, produce, and deploy), sustainment (operations and support), and disposal.

---

### PRINCIPAL LIFE CYCLE LOGISTICS GOALS/OBJECTIVES

- Goal 1: Define supportability objectives and establish life cycle sustainment metrics.
- Goal 2: Influence system design for affordable system operational effectiveness.
- Goal 3: Design and develop the support system utilizing performance-based life cycle product support.
- Goal 4: Acquire and deploy efficient and effective product support to maintain the readiness and operational capability of the system.
- Goal 5: Continuously improve readiness and affordability through enhanced life cycle management.

---

### GOAL 1: LIFE CYCLE SUSTAINMENT METRICS

Availability Key Performance Parameter (KPP) consists of two components:



#### **Materiel Availability:**

- Development of the Materiel Availability metric is a Program Manager responsibility
- Addresses the total population of end items planned for operational use
- A measure of the percentage of the total inventory operationally capable of performing an assigned mission
- Formula:  $\text{Number of End Items Operational} \div \text{Total Population of End Items}$



**Operational Availability (A<sub>o</sub>):**

- Development of the Operational Availability metric is a Requirements Manager responsibility
- Indicates the percentage of time that a system or group of systems within a unit are operationally capable
- Formula: Uptime ÷ (Uptime + Downtime)

**Reliability Key System Attribute (KSA)**

- Development of the Reliability metric is a Requirements Manager responsibility
- Measure of the probability that system will perform without failure over a specific interval
- Must support both Availability metrics

**Ownership Cost Key System Attribute (KSA)**

- Development of the Ownership Cost metric is a Program Manager responsibility
- O&S value should cover the planned life cycle timeframe
- Balance to the sustainment solution by ensuring O&S costs are considered
- Use the CAIG Cost Estimating Structure

**Mean Downtime Sustainment Outcome Metric**

- Average total Downtime required to restore an asset to its full operational capabilities
- “Umbrella” metric that captures all causes of system Downtime
- Formula: Total Downtime for All Failures ÷ Total Number of Failures

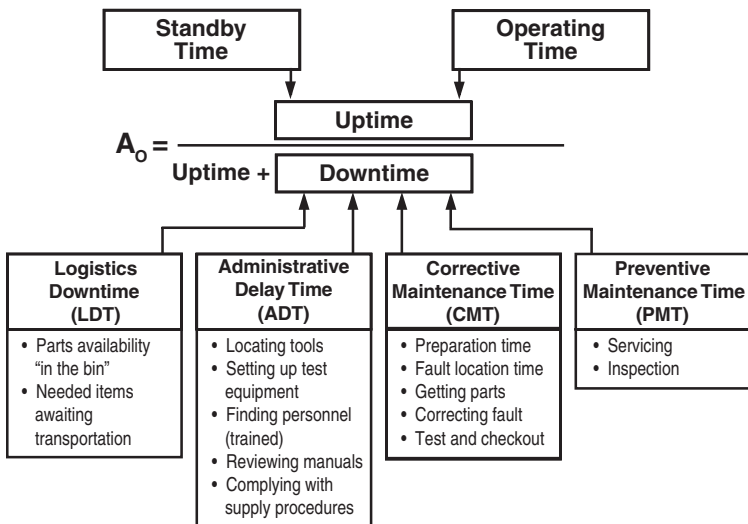

## GOAL 2: AFFORDABLE SYSTEM OPERATIONAL EFFECTIVENESS (SOE)

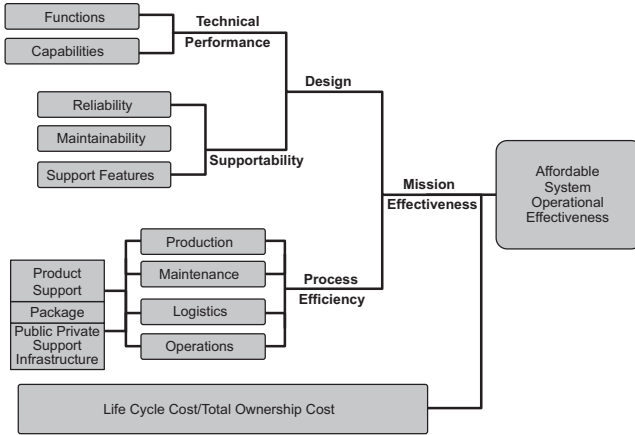

To achieve Affordable System Operational Effectiveness (SOE), the PM should design for the optimal balance between technical performance (including Reliability, Availability, and Maintainability (RAM)), categories of ownership cost, schedule, and process efficiencies. A development program that targets only some categories of technical performance capability; or fails to optimize system RAM technical performance, risks financial burden during operations and support.

---

## GOAL 3: DOD PRODUCT SUPPORT STRATEGY PROCESS MODEL

- A product support strategy encompasses the means by which defense system sustainment is to be accomplished.
- The Life-Cycle Product Support Strategy Process Model represents the major activities required to implement, manage, evaluate, and refine product support over the system life cycle. It is not a one-time process, but rather a continuing, iterative process in which the sustainment of a system (or systems) is adapted and evolved to optimally support the needs and requirements of the warfighter in an affordable and effective manner.



### 12-Step Process Model

<<https://acc.dau.mil/pbl>>

## GOAL 4: INTEGRATED PRODUCT SUPPORT ELEMENTS

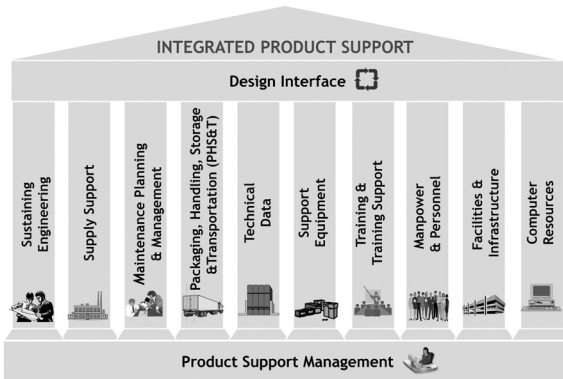

(See next page for details)

**Product Support Management:** Plan, manage, and fund weapon system product support across all Integrated Product Support (IPS) Elements.

**Design Interface:** Design interface is the integration of the quantitative design characteristics of systems engineering (reliability, maintainability, etc.) with the functional logistics elements (i.e., integrated product support elements) described below.

**Sustaining Engineering:** Those technical tasks (engineering and logistics investigations and analyses) to ensure continued operation and maintenance of a system with managed (i.e., known) risk.

**Supply Support:** Management actions, procedures, and techniques necessary to determine requirements to acquire, catalog, receive, store, transfer, issue and dispose of spares, repair parts, and supplies.

**Maintenance Planning and Management:** Establishes maintenance concepts and requirements for the life of the system for both hardware and software.

**Packaging, Handling, Storage, and Transportation (PHS&T):** The combination of resources, processes, procedures, design, considerations, and methods to ensure that all system, equipment, and support items are preserved, packaged, handled, and transported properly.

**Technical Data:** Represents recorded information of scientific or technical nature, regardless of form or character (such as equipment technical manuals and engineering drawings), engineering data, specifications, standards, and Data Item Descriptions (DID).

**Support Equipment:** Consists of all equipment (mobile or fixed) required to support the operation and maintenance of a system.

**Training and Training Support:** The policy, processes, procedures, techniques, Training Aids Devices Simulators and Simulations (TADSS), planning and provisioning for the training base including equipment to acquire, operate, maintain, and support a system.

**Manpower and Personnel:** Involves the identification and acquisition of personnel (military and civilian) with the skills and grades required to operate, maintain, and support systems over their lifetime.

**Facilities and Infrastructure:** Consists of the permanent and semi-permanent real property assets required to support a system, including studies to define types of facilities or facility improvements, location, space needs, environmental and security requirements, and equipment.

**Computer Resources:** Encompass the facilities, hardware, software, documentation, manpower, and personnel needed to operate and support mission critical computer hardware/software systems.

## GOAL 5: PRODUCT SUPPORT BUSINESS MODEL (PSBM)

**Recommendation:** Adopt a "product support business model" that drives cost-effective performance and capability for the warfighter across the weapon system life cycle and enables the most advantageous use of an integrated defense industrial base.

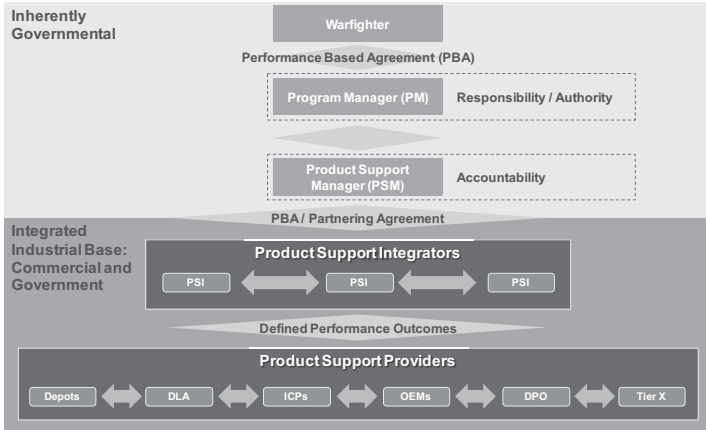

- The PSBM encompasses the overall strategy for product support planning, implementation, management, and measurement over the life cycle of a weapon system component, subsystem, or platform.
- A Product Support Manager (PSM) will provide product support subject matter expertise to the PM for execution of the PM's duties as the Total Life Cycle Systems Manager. This PSM will be designated as a key leadership position (KLP) for all Major Defense Acquisition Programs and designated a critical acquisition position (CAP) for all other major weapon systems. Product Support Integrators (PSIs) are charged with integrating all sources of product support, both public and private, defined within the scope of a product support arrangement.

## THE SUSTAINMENT CHART

The “Sustainment Chart” is one tool the PM may use for key decision-making because it readily identifies a weapon system’s product support business model and captures its operating and support costs and operational metrics data. PMs are required to use the sustainment chart to report status of sustainment planning at OIPT and DAB meetings.

SAMPLE PROGRAM: “ABC”

Date:

### Product Support Strategy

#### Sustainment Approach

- Current (initial CLS covering total system)
- Future (sub-system based PBL contracts)

#### Issues

- Shortfall in O&M funding in FYDP
- Reliability and availability estimates are below goals
- LCSP requires update before DAB

#### Resolution

- POM request for O&M restoration submitted
- Reliability improvement plan with clear RAM goals up for final signature
- LCSP in draft

### Metrics Data

Metric	Antecedent Actual	Original Goal	Current Goal	Current Estimate/Actual
Material Availability	76%	80%	77%	71%
Material Reliability	37 hrs	50 hrs	50.5 hrs	48 hrs
Ownership Cost	245.6B	385.5B	395.1B	395.1B
Mean Down Time	12 hrs	20 hrs	18 hrs	15 hrs

\* Test or fielding event data derived from \_\_\_\_\_

Notes:

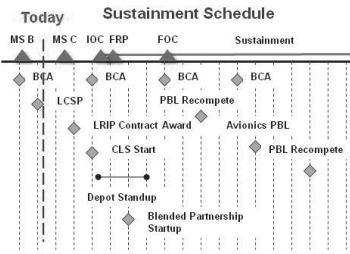

### O&S Data

Cost Element	Antecedent Cost	ABC Original Baseline	ABC Current Cost
1.0 Unit Level Manpower	3,952	5,144	5,750
2.0 Unit Operations	6,052	6,851	8,852
3.0 Maintenance	0,739	0,605	0,898
4.0 Sustaining Support	2,288	2,401	2,401
5.0 Continuing System Improvements	0,129	0,025	0,035
6.0 Indirect Support	1,846	1,925	1,956
<b>Total</b>	<b>15,046</b>	<b>16,951</b>	<b>17,682</b>

Cost based on average annual cost per squadron

Total O&S Costs	Antecedent	ABC
Base Year \$M	102,995.2	184,011.9
Three Year \$M	245,665.3	395,147.2

## LOGISTICS MANAGEMENT COMMUNITY OF PRACTICE (LOG COP)

*Transforming the Way We Work*

Where YOU can ....

### Find Helpful Tools and Templates

- Latest PBL Resources
- Supportability Best Practices
- Contracting Lessons Learned

### Get Ahead In YOUR Career

- Logistics Training and Education
- Latest OSD Policy and Direction
- Logistics Conferences/Events
- Link to Top DoD Websites

### Connect With Professionals

- Share Experiences and Ideas
- Start and Join Discussions

<http://acc.dau.mil/log>

- Locate DoD and Industry Experts

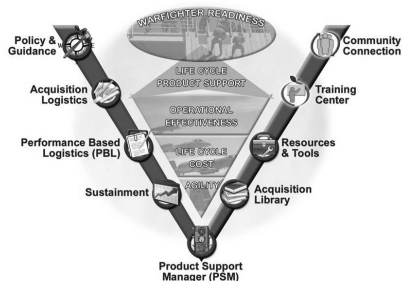

# LIFE CYCLE LOGISTICS LINKAGE TO DEFENSE ACQUISITION PROCESS

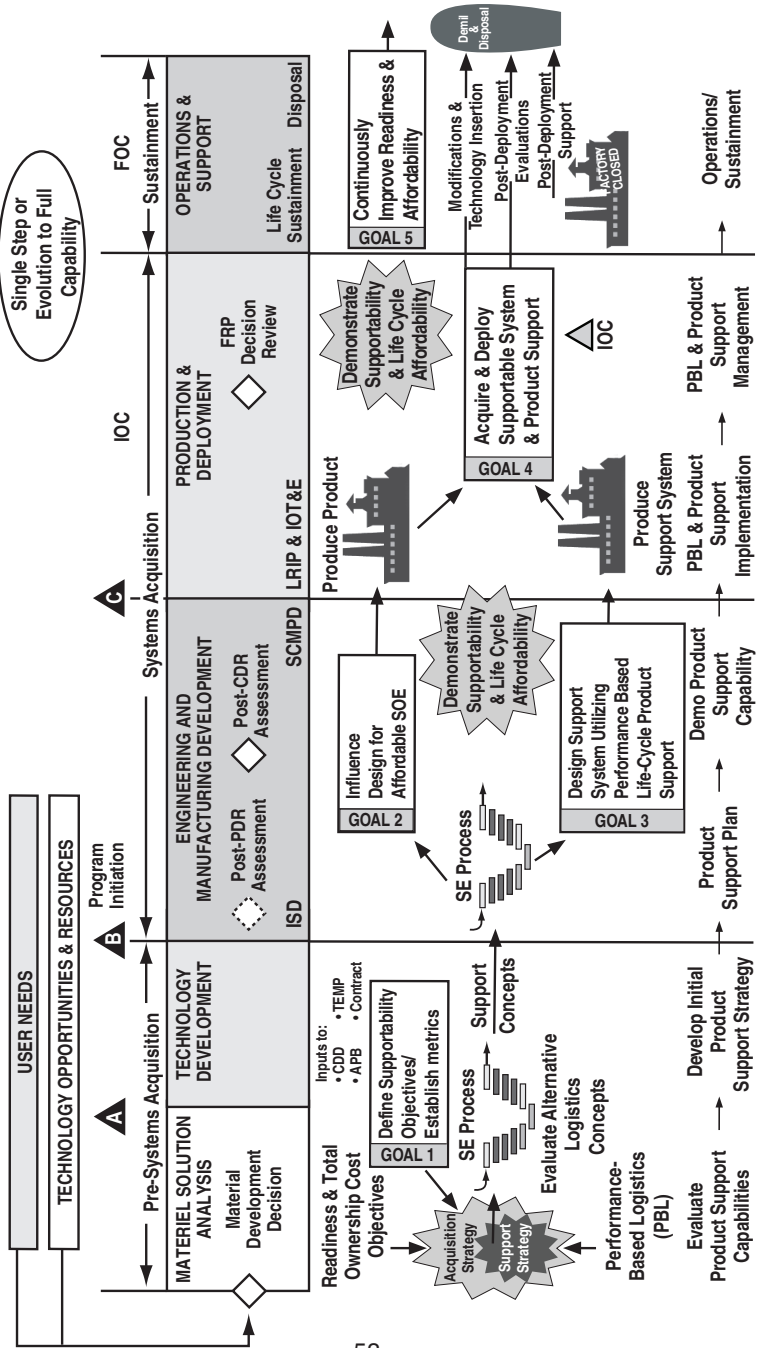

# DEFENSE ACQUISITION GUIDEBOOK LIFE CYCLE LOGISTICS <[https://acc.dau.mil/dag\\_5](https://acc.dau.mil/dag_5)>

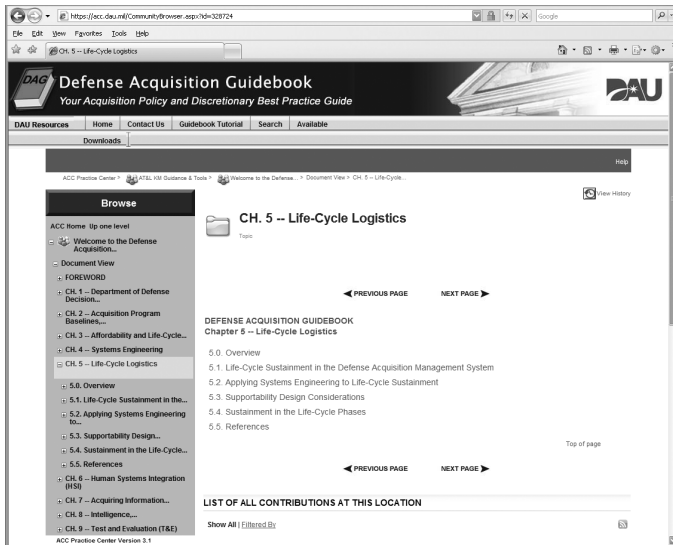

## LIFE CYCLE LOGISTICS REFERENCES & GUIDANCE

- Defense Acquisition Guidebook (DAG) Chapter 5 - [https://acc.dau.mil/dag\\_5](https://acc.dau.mil/dag_5)
- DAU Logistics Community of Practice (LOG CoP) - <https://acc.dau.mil/log>
- Product Support Manager (PSM) Homepage - <https://acc.dau.mil/psm>
- PSM ACQuipedia Site - <https://acc.dau.mil/CommunityBrowser.aspx?id=375980>
- Performance Based Life Cycle Product Support (PBL) Toolkit - <https://acc.dau.mil/pbl>
- Life Cycle Sustainment Plan (LCSP) - <https://acc.dau.mil/lcsp>
- DoD Logistics Human Capital Strategy (HCS) - <http://www.acq.osd.mil/log/sci/hcs.html>
- Life Cycle Logistics ACQuipedia Repository - [https://acquipedia.dau.mil/log\\_lcic.aspx](https://acquipedia.dau.mil/log_lcic.aspx)
- Life Cycle Logistics Blog - <https://dap.dau.mil/career/log/blogs/default.aspx>
- Recommended Reading List - <https://acc.dau.mil/CommunityBrowser.aspx?id=383460>
- Logistics Career Field Gateway - <https://dap.dau.mil/career/log>
- DAU Life Cycle Logistics Media Library - <http://www.dau.mil/mpi/default.html>
- Integrated Defense AT&L Life Cycle Framework Chart - <https://ilc.dau.mil/>
- Army Life Cycle Logistics Framework Chart - <https://acc.dau.mil/logsa>
- Joint Life Cycle Logistics Framework Chart - Will be posted on the LOG CoP
- *Product Support Manager's* (PSM) Guidebook - Will be posted on the LOG CoP
- Business Case Analysis (BCA) Guidebook - Will be posted on the LOG CoP
- *Life Cycle Logistics Guidebook* - Will be posted on the LOG CoP

## PROGRAM OFFICE ORGANIZATION STRUCTURES (Examples)

### “Traditional” or Functional Structure

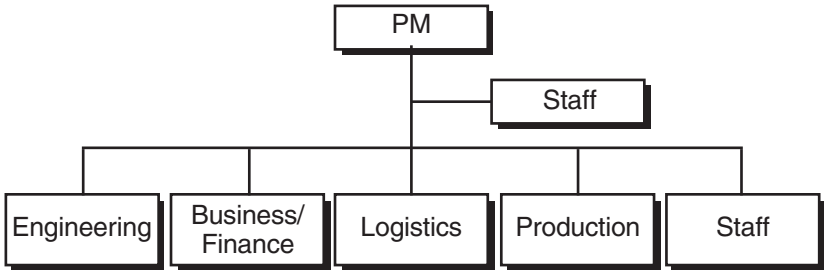

Note: Functional divisions shown are notional.

### “Pure” Product Structure

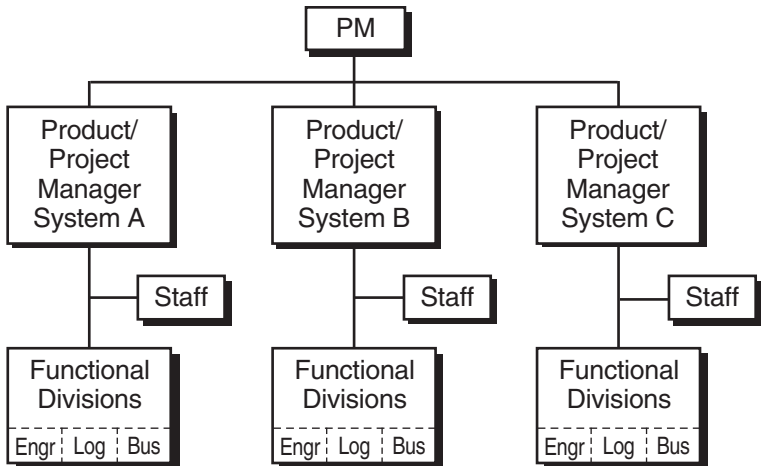

**Note:** Functional divisions shown are notional.

<b>LEGEND:</b>		
Engr—Engineering	Log—Logistics	Bus—Business

# PROGRAM OFFICE ORGANIZATION STRUCTURES

(Continued)

## Matrix Structure

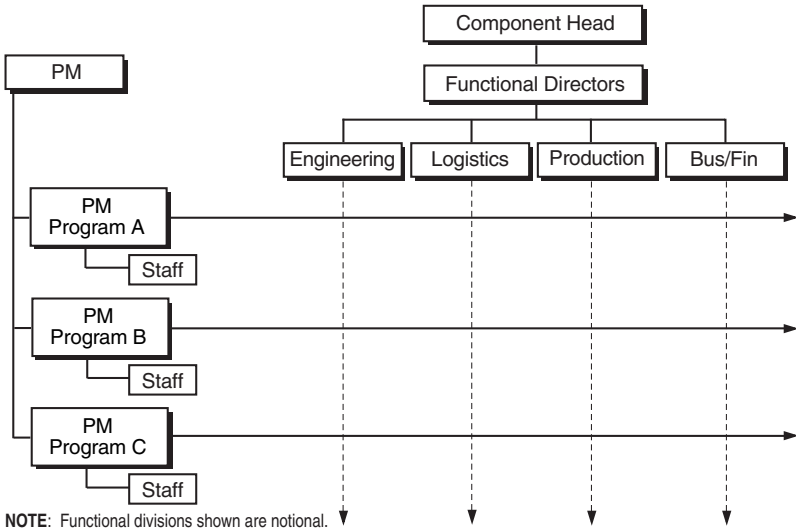

## Integrated Product Teams

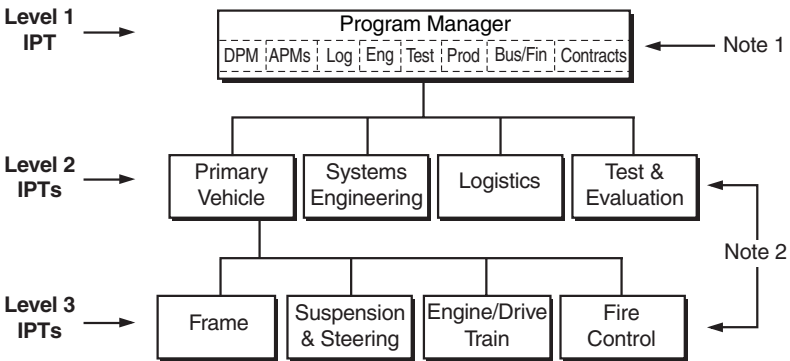

## THE ROLE OF MANUFACTURING IN THE ACQUISITION PROCESS

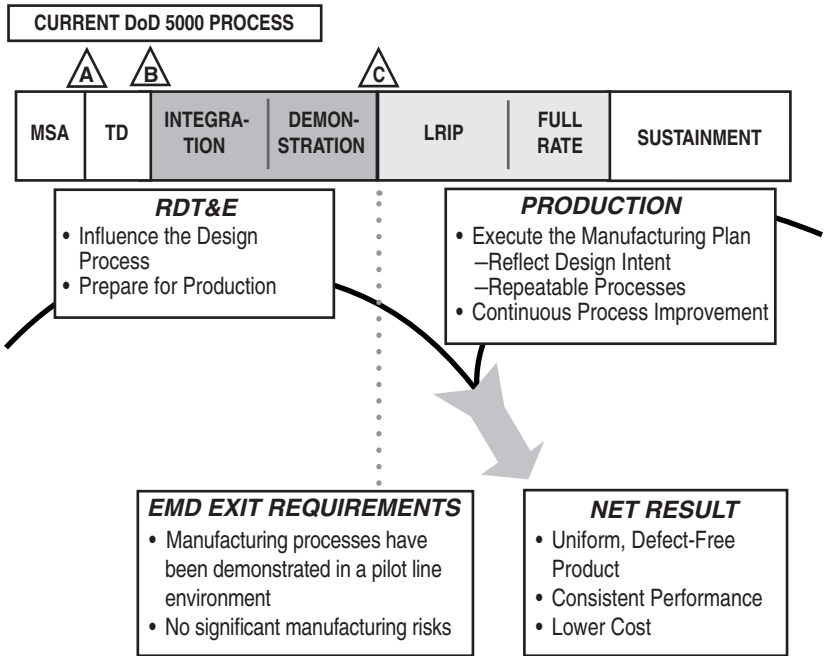

### COMMON PRODUCTION RISKS THAT GREATLY IMPACT COST, SCHEDULE, AND PERFORMANCE

- Unstable requirements/engineering changes
- Unstable production rates and quantities
- Insufficient process proofing
- Insufficient materials characterization
- Changes in proven materials, processes, subcontractors, vendors, components
- Producibility
- Configuration management
- Subcontractor management
- Special tooling
- Special test equipment

## PRODUCIBILITY

### DEFINITION:

The measure of relative ease of manufacturing a product. The product should be easily and economically fabricated, assembled, inspected, and tested with high quality on the first attempt that meets performance thresholds.

### PRODUCIBILITY ISSUES:

- Design engineering, NOT manufacturing, is the technical group responsible for producibility. Program offices and design engineers often dislike producibility because it usually requires performance functionality sacrifices (especially if cost is a set value, i.e., CAIV).
- Many design engineers do not have proper training or experience in designing for producibility. Manufacturing facilities must be explicitly recognized as a major design constraint. This includes process capabilities and rate capabilities at each facility.

***The PM is responsible for Producibility***

---

### **Producibility**

(see *Defense Acquisition Guidebook*)

- Producibility: degree to which system design facilitates timely, affordable, optimum-quality manufacture, assembly, and delivery of system.
- Producing system design should be a development priority.
- Design engineering efforts concurrently develop:
  - Producing and testable design;
  - Capable manufacturing processes; and
  - Necessary process controls to:
    - ◆ Meet requirements, and
    - ◆ Minimize manufacturing costs.
- PM should use existing manufacturing processes whenever possible.
- When design requires new manufacturing capabilities, PM needs to consider process flexibility (e.g., rate and configuration insensitivity).
- Full-rate production necessitates:
  - Stable systems design;
  - Proven manufacturing processes; and
  - Available production facilities and equipment.

## Quality Management Systems (see *Defense Acquisition Guidebook*)

- The PM should allow contractors to define and use their preferred quality management system that meets required program support capabilities.
- The PM will not require International Standards Organization (ISO) registration of a supplier's quality system since there have been instances where ISO 9001-registered supplier products were deficient or life-threatening.
- Contractor's quality management system should be capable of the following key activities:
  - Monitor, measure, analyze, control, and improve processes;
  - Reduce product variation;
  - Measure/verify product conformity;
  - Establish mechanisms for field product performance feedback; and
  - Implement an effective root-cause analysis and corrective action system.

**NOTES:** ISO 9000 Series International Quality Standard is considered a Basic Quality system, but the focus is still on "Document what you do. Do what you document."

Advanced Quality Systems (AQS), such as the new SAE AS9100B Aerospace industries' quality standard, focus on achieving customer satisfaction via use of key characteristics identification and control, variation reduction of key characteristics, flow-down of similar process control requirements to suppliers, and many other advanced process-oriented control and improvement techniques.

### Key Characteristics and Variation Reduction

**GOAL**—Minimize and control variation on both key product characteristics and corresponding key manufacturing process characteristics:

- **Key Characteristics:** The features of a material, process, or part whose variation has a significant influence on product fit, performance, service life, or manufacturability—per SAE AS9100B.
- **Major Sources of Variation:** Insufficient design margins, process (manpower, machinery, methods, etc.), measurement systems, supplier's products.

**WHY:** Direct correlation between deviation from nominal value (i.e., variation) on key characteristics and product quality and functionality.

**TOOLS:** Quality Function Deployment (QFD), Design of Experiments (DOE), Statistical Process Control. (See control chart on next page.), Continuous Process Improvement (CPI)/Lean Six Sigma (LSS) Program.

## Key Characteristics and Variation Reduction (Continued)

$\bar{X}$  (Control Chart)

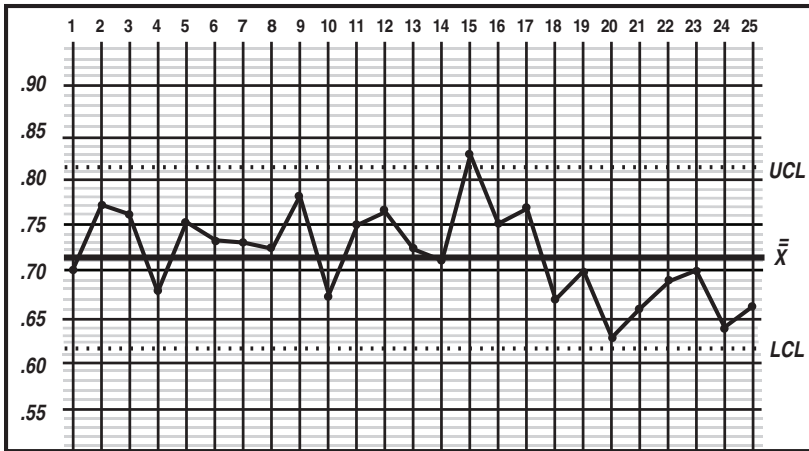

R (Control Chart)\*

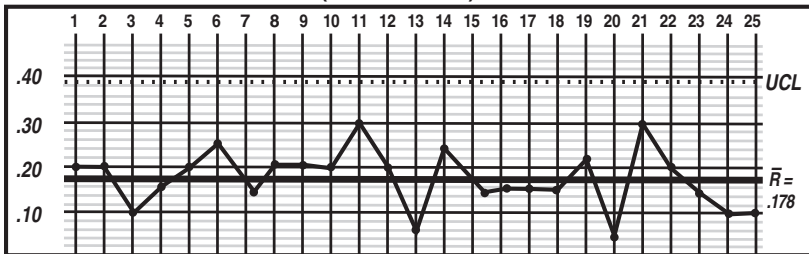

\*Note: No lower control limit for R chart for sample size below 7.

The  $\bar{X}$  (X bar) and R Control Charts are used to monitor manufacturing processes. Upper or Lower Control Limits (UCL or LCL) are **NOT** design specification parameters. Instead, they are predicted boundaries for stable processes, calculated using  $\bar{\bar{X}}$  (X double bar) (average of sampled process Means),  $\bar{R}$  (R Bar) (the average of the sample Ranges, which are the spreads between extreme values per sample), plus the selected data sample size and process-keyed statistical formulas. Values outside the UCL and/or LCL indicate possible process instability, likely due to uncommon "special" causes of variation.

**Caution:** A process in control is desirable because it is predictable, yet it could fail to meet design requirements due to inherent "common" variation and/or because the process average isn't centered on the design nominal value.

Reference: *The Memory Jogger™ II*; ©1994 by GOAL/QPC.

## Production Readiness Review (PRR)

### **WHY WE DO THEM**

- Risk Management Tool: Identify program risks and issues and opportunities early and often (small, incremental, proactive vice big, single, reactive).
- Assess capability of contractor (and subcontractor) to deliver a product on time and within cost that meets performance and quality requirements.
- Assess actual contractor performance (metrics).
- Assess effectiveness of contractor's corrective/preventative actions.
- Measure improvement of contractor's performance.

### **HOW TO DO THEM**

- Write a charter that the program office and contractor both understand.
- Coordinate with the Defense Contract Management Agency (DCMA)—use their capability.
- Establish areas of assessment with metrics:
  - Producibility;
  - Engineering Change Orders (ECO)/design stability;
  - Manufacturing process control (key characteristics);
  - Cost, time of scrap, rework, and repair;
  - Tooling status; and
  - Subcontractor management (same metrics as listed above).
- Ask questions, touch things, talk to shop floor workers:
  - ***See what is actually happening on the factory floor rather than the conference room, i.e., go see and talk to the people doing the work.***

### **WHEN TO DO THEM**

- Early and often (see *Defense Acquisition Guidebook*, 4.3.3.9.3, Production Readiness Reviews).
- Concurrently with other technical reviews, such as the System Functional Review (SFR), Preliminary Design Review (PDR), and the Critical Design Review (CDR).
- In Systems Integration and Systems Demonstration.
- “Final” PRR occurs at end of Systems Demonstration (before Milestone C).
- PRRs should be held in LRIP and beyond IF major changes (to design, manufacturing processes, rates/quantities, etc.) occur during LRIP.

## Additional Manufacturing Information Sources

- DAU's Production, Quality and Manufacturing Information Website:
  - Go to <[www.dau.mil](http://www.dau.mil)>; select Knowledge Sharing; select Acquisition Community Connection; then see Participate in a Community; and select Production, Quality and Manufacturing.
  - Contains references to subjects including DoD Manufacturing Requirements, and Best Business Practices, such as Lean Enterprise, e-Commerce, Six Sigma, Basic and Advanced Quality Systems, Supply Chain Management, etc.
- Best Manufacturing Practices Center of Excellence—<[www.bmpcoe.org](http://www.bmpcoe.org)>.
- Lean Aerospace Initiative (LAI)—<<http://lean.mit.edu>>.

## TEST AND EVALUATION (T&E)—TYPES AND TASKS

### *Developmental T&E (DT&E)/Operational T&E (OT&E) Comparisons*

**DT&E**

- Technical performance measurement
- Developmental agency responsible (PM)
- Technical personnel
- Limited test articles/each test
- Controlled environment
- All types of test articles
- Contractor involved

**OT&E**

- Operational effective/suitable
- Operational Test Agency (OTA) responsible
- “Typical” user personnel
- Many test articles/each test
- “Combat” environment/threats
- “Production Rep” test articles
- Contractor may not be allowed (IOT&E)

### **T&E Required Before Going Beyond Low Rate Initial Production**

- **Production Qualification T&E**—Verify design article meets spec/PM responsible; performed by contractor and/or Government/DPRO assistance valuable. Readiness for IOT&E.
- **Live Fire T&E (LFT&E)**—Vulnerability and Lethality/Developmental Agency fund and execute. DOT&E oversight, approval, and Congressional reporting (LFTE Report) for ACAT I, II, and selected programs.
- **Initial Operational T&E (IOT&E)**—Operational Effectiveness and Suitability/Independent Service OTA plan and manage. DOTE oversight, approval, and Congressional reporting (BLRIP Report) for ACAT I and selected systems.

### **T&E Tasks and Events**

#### **Models and Simulations Used Throughout the Acquisition Process**

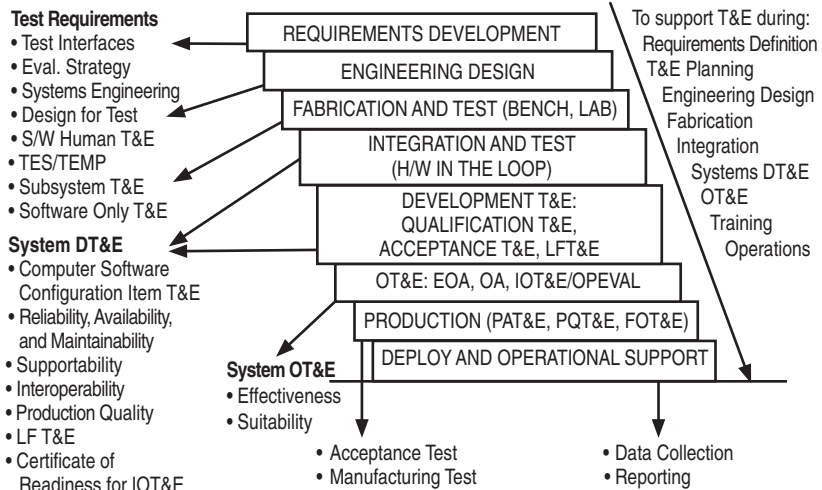

**Use Integrated DT/OT**—Single integrated contractor/government DT and OT team; shared test events and test data; independent data analysis and reporting.

**ACAT I and II Programs**—Require an independent, dedicated IOT&E to proceed beyond Low Rate Initial Production (LRIP).

**Joint Interoperability Test Certification**—All Information Technology and National Security Systems must be evaluated and certified by the Joint Interoperability Test Command (JITC) prior to (initial or updated) fielding, and periodically during their entire life - as a minimum, every four (4) years.

## TEST AND EVALUATION NOMOGRAPH

**What is a nomograph?** A two-dimensional graphical representation of the cumulative binomial distribution.

**Why use nomograph?** It enables a relatively simple solution to a complex mathematical calculation.

**What does it do?** It allows you to calculate the performance of an item with associated statistical confidence.

**When do you use it?**

- When your requirement includes a “Confidence Level” with a specific level of performance. For example: THIS missile must hit THAT target 90 percent of the time with 80 percent statistical confidence?
- When the performance of an item under test can be characterized by a binomial distribution.

**What are the characteristics of a binomial distribution?**

- Result of each event (firing) is an independent from other events.
- Probability of success of each event is constant.
- Each event results in a “success” or a “failure.” (In other words, there are no points for being close; each event must be scored as a hit or a miss.)

**What are some examples of binomially distributed events?**

- Coin flip
- Missile launch
- Rocket firing
- Starting a car

**BOTTOM LINE:** Each of these test events must be graded as “pass” or “fail,” and you must determine the success criteria before the test begins.

The nomograph can be used (pre-test) as a test planning device to determine how many tests will be necessary to verify that specified performance has been met. The nomograph can also be used (post-test) to evaluate test data.

**NOTE:** There are two axes on the nomograph. One axis is the total number of trials. The other axis is the total number of failures. Additionally, the nomograph is non-linear.

# DAU PROGRAM MANAGERS TOOL KIT

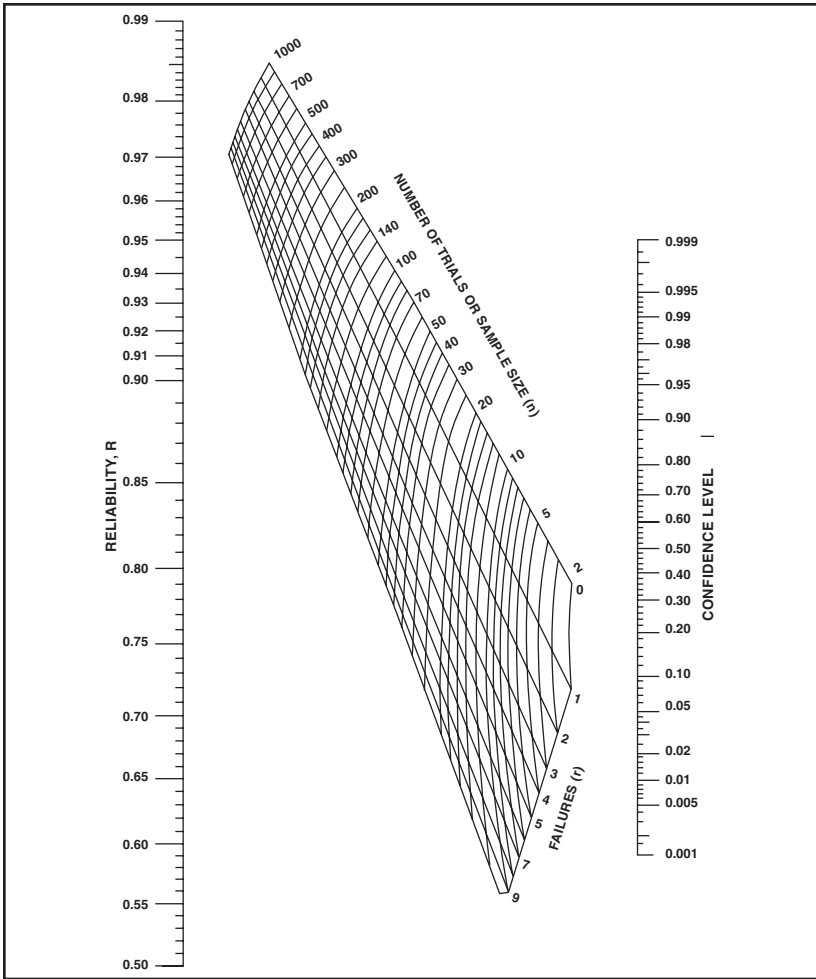

**How do you get a solution?**

- From the data, determine the number of trials (total number of coin flips or missile shots, etc.) and locate the appropriate line on the nomograph.
- Determine the number of failures and locate the appropriate line on the nomograph.
- Draw a point at the intersection of these two lines on the nomograph.
- Any straight line drawn through this point is a valid solution for the data set used.

**For example:**

- Requirement: Your missile must hit the target at least 90% of the time, with at least 80% confidence.
- Given: You fired 20 missiles with 19 hits and 1 failure.
- What is the statistical confidence that you will have 90% success in the field with these missiles fired against THAT target?  
Answer: 60% confidence.
- Did you meet the requirement? NO, you achieved only 60% confidence of hitting THAT target 90% of the time, and the requirement was 80% confidence or better. One other way to look at the same data is to say that you did achieve 90% probability of success, but you only had 60% confidence in this result; either way you look at it, you did not meet the requirement.

**NOTE:** If you had fired 30 missiles and missed only 1 time, you would have achieved the 80% confidence along with the required 90% performance level.

## MODELING AND SIMULATION (M&S) PLANNING

- Access your service centers for M&S expertise
- Establish a simulation coordinating group; the EARLIER the better
- Design long-term M&S applications and the Integrated Digital Environment through the acquisition strategy, Test and Evaluation Management Plan (TEMP), Source Selection Plan (SSP)
- Create constructive, virtual, or live models and simulations
- CONTINUOUS PLANNING ↔ PROGRAM PLANNING

TEST AND EVALUATION STRATEGY/TEMP



### HOW DO WE PLAN?—A NOTIONAL APPROACH

#### Integrated Digital Environment (IDE) Planning

- Establish a business process improvement team
- Identify high payback process areas
- Identify potential legacy systems and data repositories
- Identify user base, including remote sites
- Capacity of PC workstations
- Bandwidth of communication lines
- Where servers are/will be located
- Identify legacy system host platforms

#### Modeling and Simulation (M&S) Planning

- Identify high payback process areas
- Identify potential legacy systems, Service/Joint-standard simulations, architectures and data repositories
- Identify where user and simulators are/will be located
- Determine capabilities and architectures of existing simulations
- Network bandwidth requirements
- IDE utilization opportunities
- Interoperability/interface/immersion requirements
- Required capability cap
- Design M&S architectures
- Establish a Simulation and Verification, Validation, and Authentication (SVV&A) planning process
- Establish long-term plan, budget, document and implement
- Manage, update, and implement the SSP

Simulation Support Plan (SSP)  
(Required by Army, Marine Corps, and Air Force)

# HIERARCHY OF MODELS AND SIMULATIONS

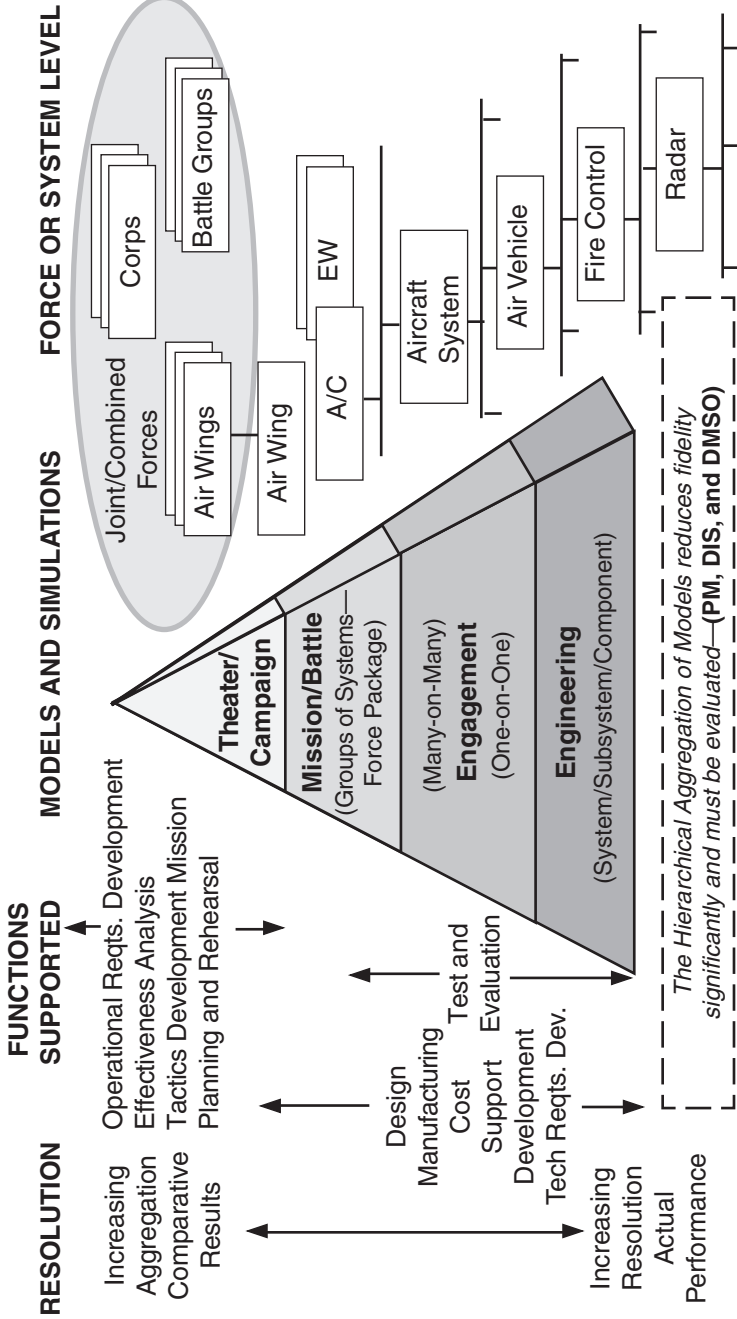

**LEGEND:**  
 DIS—Distributed Interactive Simulation      DMSO—Defense Modeling and Simulation Office

# THE EVOLUTION OF MODELING AND SIMULATION

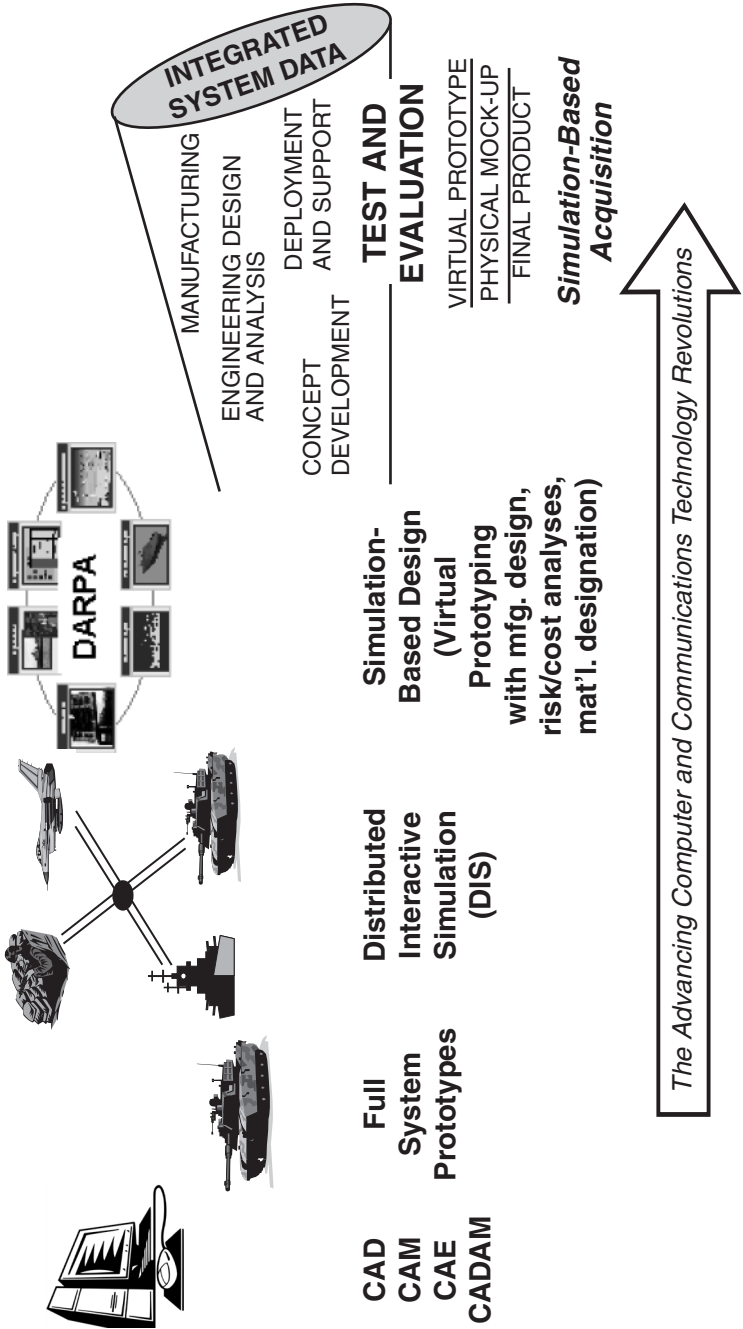

## GANTT CHART

(Example)

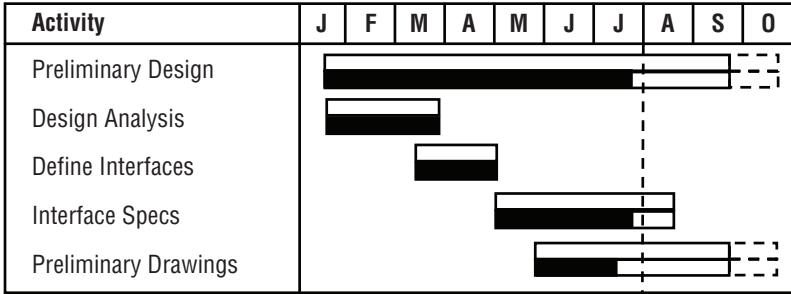

Symbol	Meaning
	Planned activity schedule
	Status of activity
	Forecast completion behind schedule
	Forecast completion ahead of schedule

Current Date

**NOTE:** There is no standard set of Gantt chart symbols.

- Shows planned start and finish dates; may also show progress.
- Depicts activities as horizontal bars imposed over a time line.
- Primary strengths are simplicity and depicting overall project plan and status.
- Can show dependencies between activities (can be difficult to read as the number of activities and dependencies between activities increases).

## MILESTONE CHART

(Example)

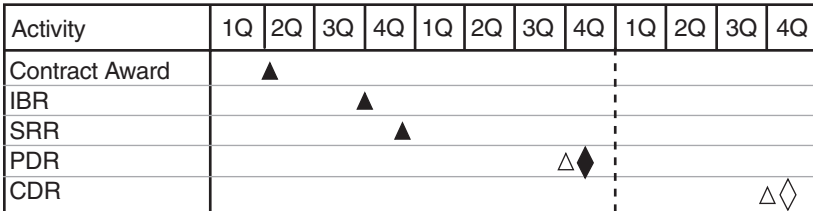

Symbol	Meaning
△	Planned event completion
▲	Actual event completion
△◆	Actual completion behind schedule
△◇	Forecast completion behind schedule

Current Date

- Shows when key events are scheduled and when they are actually accomplished.
- Primary strengths are simplicity and depicting information at the “big picture” level.
- Does not show progress related to events or dependencies between events.

## NETWORK SCHEDULES

### Network Schedules—General

- Graphically portray dependencies and constraints among project activities and the sequence in which the activities occur.
- Allows managers to conduct a systematic, disciplined, and thorough review of the activities required to complete the project.
- Provides information about early and late start and finish times.
- Used to determine the project’s critical path, and slack or float in schedule activities.
- Generally, there are two types of networks: Arrow Diagramming Method (ADM) and Precedence Diagramming Method (PDM).



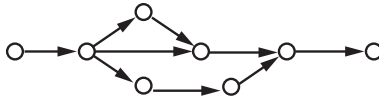

### Arrow Diagramming Method (ADM)

- Also known as Activity-on-Arrow (AOA); information about activities is shown above/below the arrows connecting events in the schedules. Events are usually shown as circles, squares, or rectangles (see following page).
- ADM generally treats all relationships (see below) as finish-to-start (i.e., first activity must finish before the next activity can start).
- ADM can show other relationships (e.g., start-to-start, finish-to-finish) through the use of “dummy” activities.



### Precedence Diagramming Method (PDM)

- Also known as Activity-on-Arrow (AON); information about activities is shown in/on the network nodes. Nodes are usually shown as squares or rectangles (see following page).
- Lines connecting the nodes show the relationships between the activities.
- PDM can show all forms of schedule relationships, including lead and lag situations (see below).

 <p><b>Finish-to-Start.</b> Activity “A” must finish before Activity “B” can start.</p>	 <p><b>Start-to-Start.</b> Activity “A” must start before Activity “B” can start.</p>
 <p><b>Finish-to-Finish.</b> Activity “A” must finish before Activity “B” can finish.</p>	 <p><b>Start-to-Finish.</b> Activity “A” must start before Activity “B” can finish. Rarely used.</p>

# NETWORK SCHEDULES (EXAMPLE)

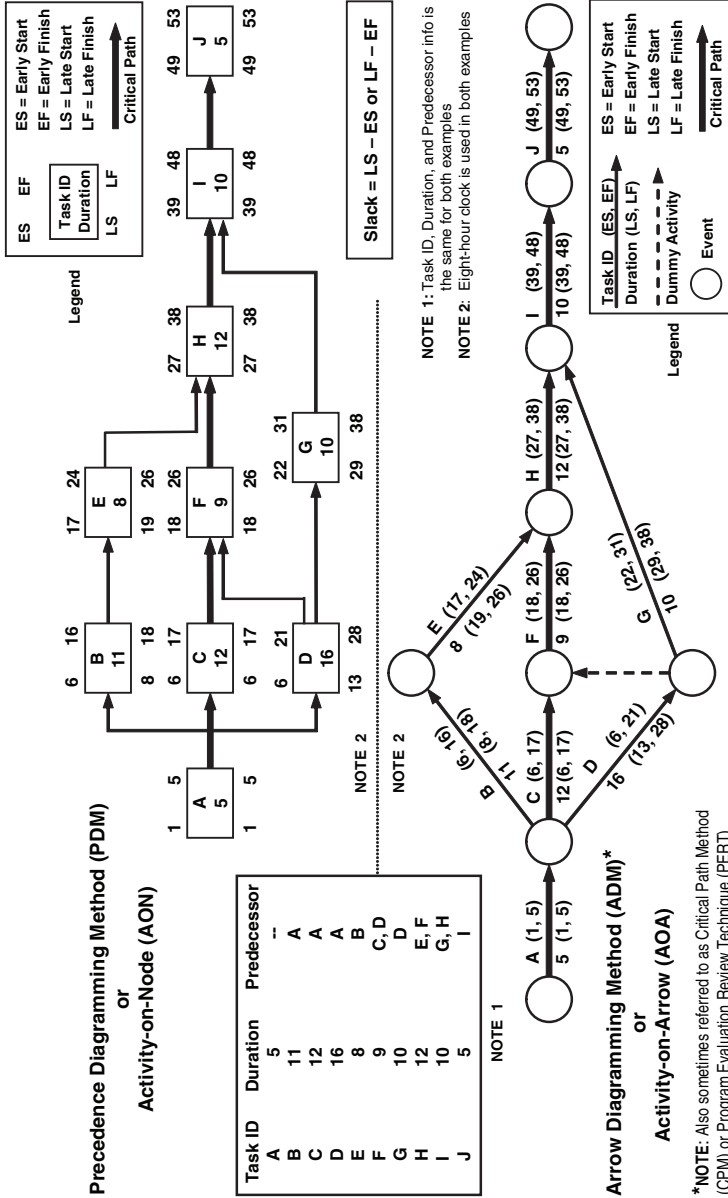

# EXAMPLES OF NETWORK SCHEDULING SOFTWARE

**Gantt Chart View**

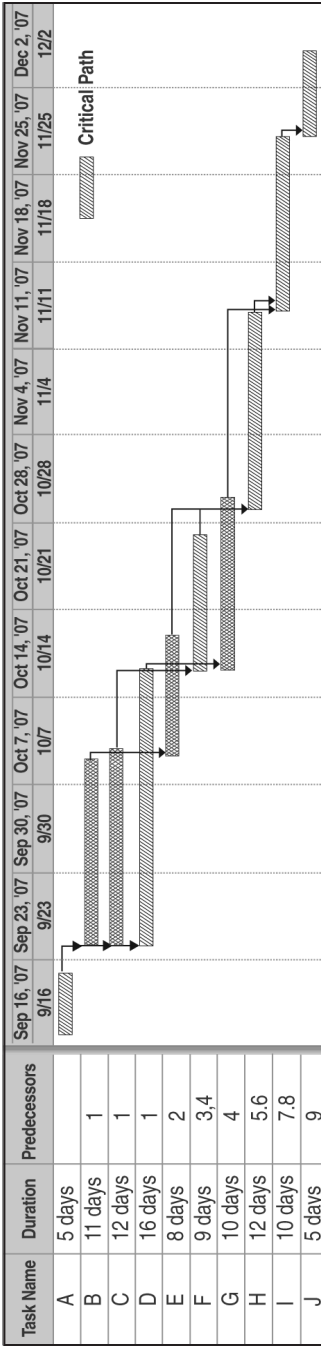

NOTE: Task name, duration, and predecessor information is the same as in Network Schedule on the previous page.

**Network View**

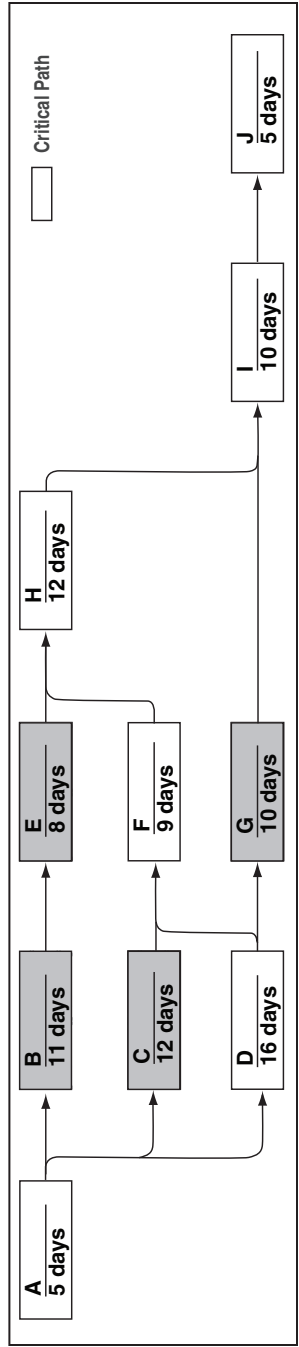

**SCHEDULE DEVELOPMENT**

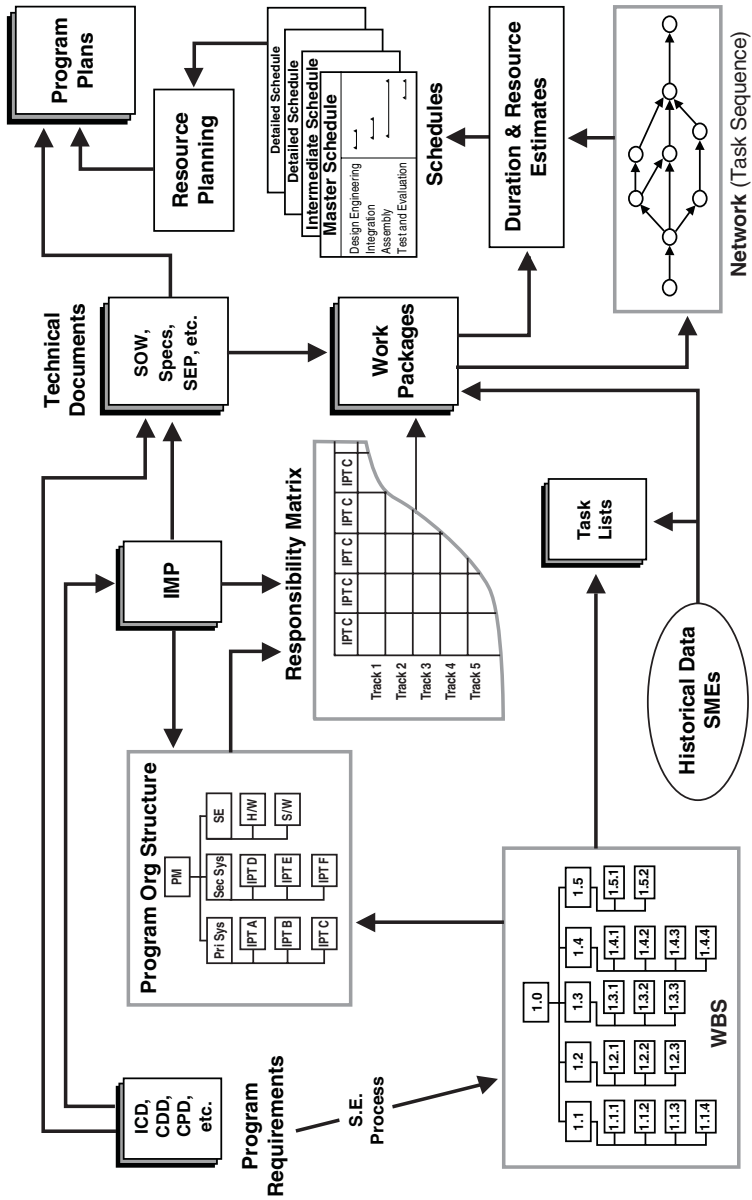

### LEAD TIME CHART

(Use with "Line of Balance Technique" on next page.)

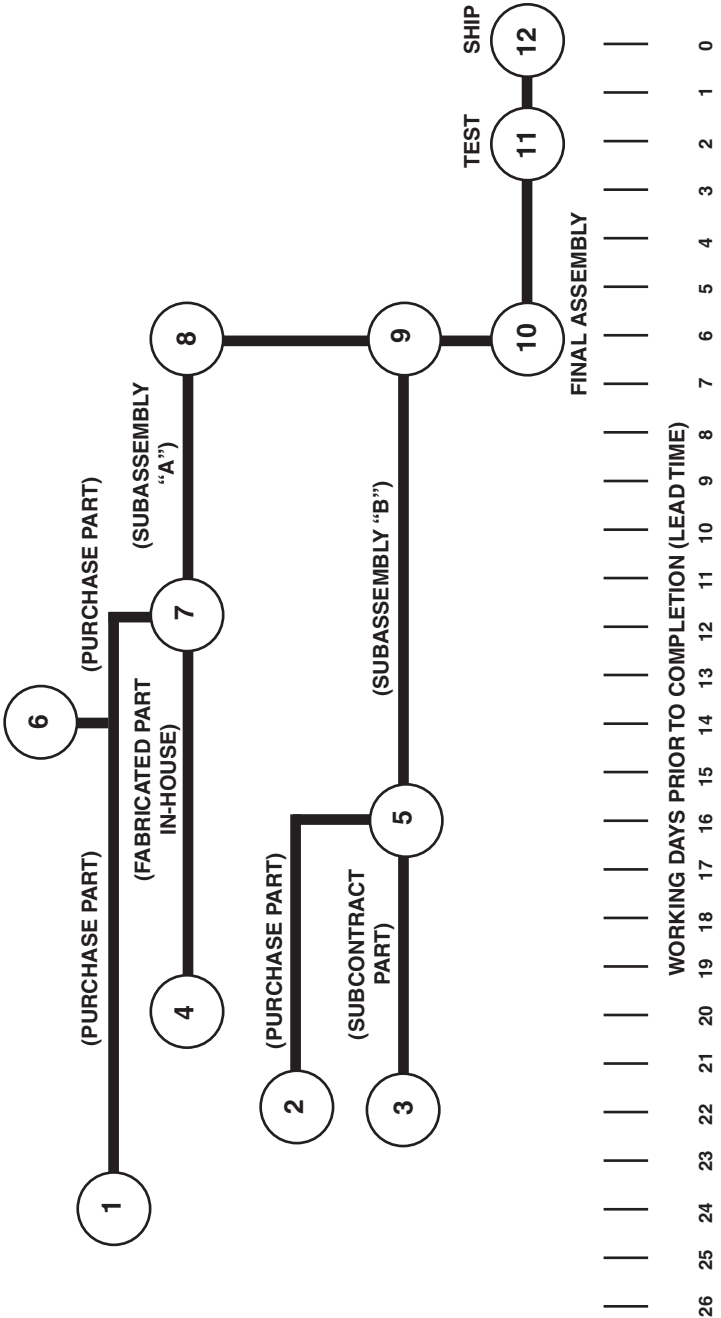

### LINE OF BALANCE TECHNIQUE

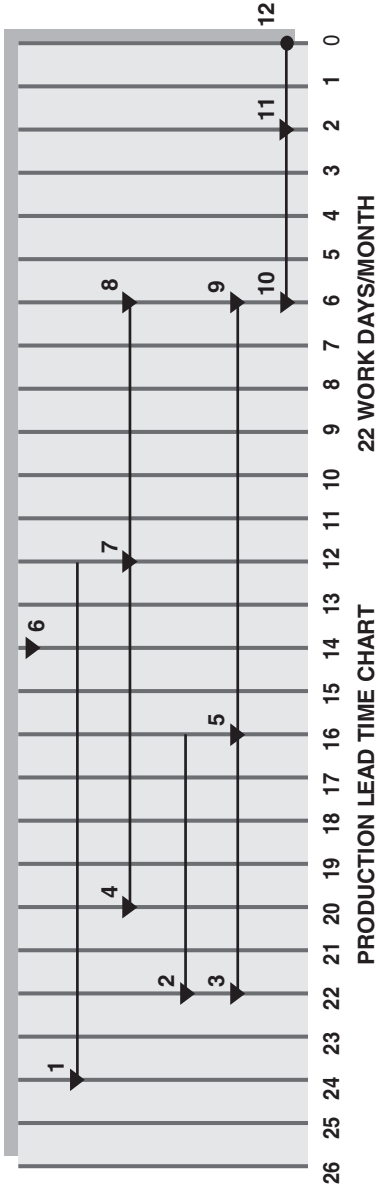
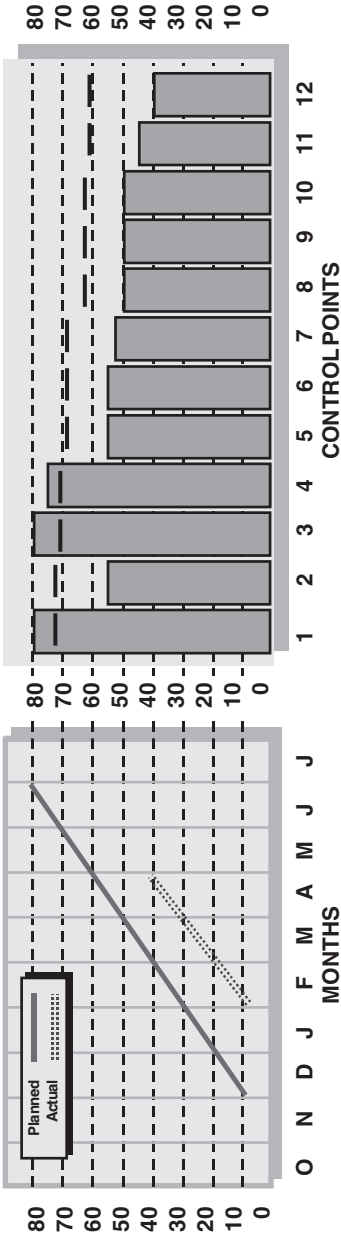

Snapshot in time: 1 May

## ACQUISITION PROGRAM BASELINE Key Performance Parameter (KPP)—An Example

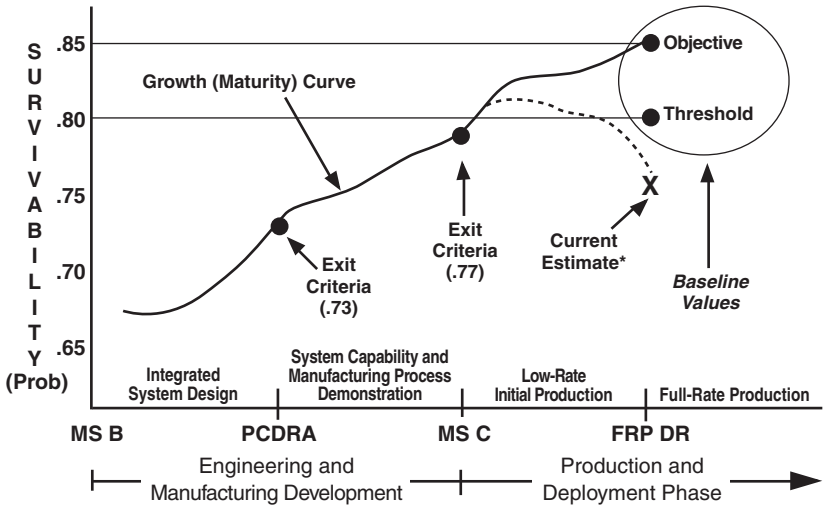

\*In this example, the current estimate falls below the threshold—this represents a baseline breach of performance.

- Every program must have an APB starting at program initiation (normally Milestone B).
- The APB reflects the threshold and objective values for a minimum number of cost, schedule, and performance parameters that describe the program over its life cycle.
- Cost thresholds and objectives reflect major elements of life cycle cost (RDT&E, procurement, PAUC, APUC, etc.).
- Schedule thresholds and objectives reflect critical events (milestone decisions, start of DT/OT, first flight, IOC, etc.).
- Performance thresholds and objectives are key performance parameters (KPPs) extracted verbatim from the CDD/CPD.
- The JROC requires KPPs for force protection, survivability, sustainment (availability), net-ready, and KPPs traceable to the Joint Pub 3-0, Joint Operations.
- The MDA may add other significant performance parameters if necessary.
- The APB is signed by PM, PEO, and CAE, as appropriate, and approved by MDA.

**LEGEND:**

APB—Acquisition Program Baseline  
 APUC—Average Procurement Unit Cost  
 CAE—Component Acquisition Executive  
 CDD—Capabilities Design Document  
 CPD—Capabilities Production Document  
 DRR—Design Readiness Review  
 DT/OT—Development Test/Operational Test  
 FRP DR—Full-Rate Production Design Review  
 IOC—Initial Operational Capability  
 JROC—Joint Requirements Oversight Council

MDA—Milestone Decision Authority  
 MS—Milestone  
 PAUC—Program Acquisition Unit Cost  
 PCDRA—Post Critical Design Review Assessment  
 PEO—Program Executive Officer  
 PM—Program Manager  
 RDT&E—Research, Development, Test and Evaluation

## PROGRAM MANAGER’S CHECKLIST FOR REVIEW OF TRADEOFF PLANNING AND STUDIES

**1. ARE ALL VIABLE ALTERNATIVES BEING EXPLORED?**

- Is each alternative clearly defined?
- Have the alternatives been prescreened? How?
- Are affordability limits established?
- Can all of the screened-out alternatives be defended?

**2. ARE SELECTION CRITERIA IDENTIFIED?**

- Are all significant criteria identified?
- Do the criteria discriminate among alternatives?
- Are the criteria measurable?
- Have the criteria been pre-approved?

**3. IS THE CRITERIA WEIGHTING SYSTEM ACCEPTABLE?**

- Are rationales for criteria weights explained?
- Are criteria weights consistent with guidance?
- Are criteria weights consistently distributed in the tree?

**4. ARE UTILITY (SCORING) CRITERIA DETERMINED?**

- Is defensible rationale established for each criterion?
- Are criteria developed from operational measures of effectiveness where possible?
- Do all plans use the same numerical scale?
- Is the location of the “zero point” explained?

**5. ARE EVALUATION METHODS DOCUMENTED?**

- Are test data reliability estimates (confidence levels) incorporated?
- Are models validated? When? By whom?

**6. HAS SENSITIVITY BEEN ESTIMATED?**

- Are error ranges carried through with worst-on-worst case analysis?
- Have the effects of changes in the utility curve shapes been examined?
- Have rationales for the limits been developed?

## TECHNICAL PERFORMANCE MEASUREMENT

### The Concept

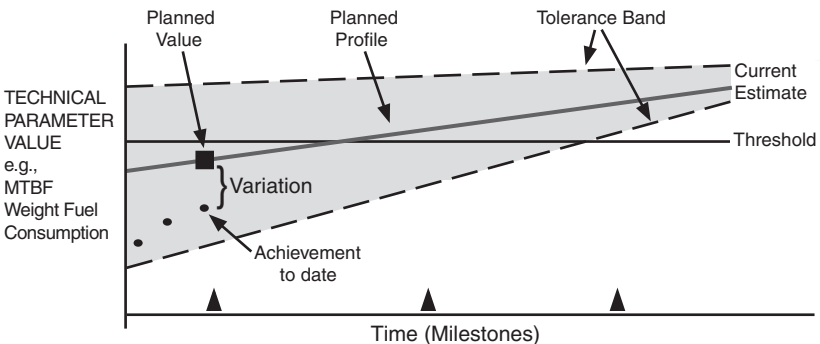

**Technical Performance Measurement** is a graphical depiction of a product design assessment. It displays values derived from tests and future estimates of essential performance parameters. It forecasts the values to be achieved through the planned technical program effort, measures differences between achieved values and determines the impact of these differences on system effectiveness. In the DoD, TPMs are typically related in some way to Key Performance Parameters (KPPs).

## DOD RISK MANAGEMENT PROCESS MODEL

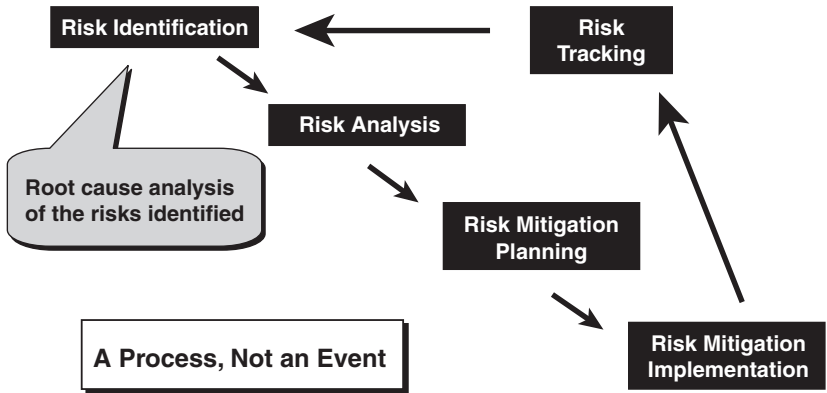

*DoD Risk Management Guide*  
August 2006

---

### ROOT CAUSE ANALYSIS

- Risk identification includes analysis to identify the root causes of the risks identified.
- Root causes are identified by examining each WBS product and process element in terms of the sources or areas of risk.
- An approach for identifying and compiling a list of root causes is to:
  - list WBS product or process elements;
  - examine each in terms of risk sources or areas;
  - determine what could go wrong; and
  - ask “why” multiple times until the source(s) is discovered.
- A common misconception and program office practice concerning risk management root cause analysis is to identify and track issues (vice risks) and then manage the consequences (vice the root causes). Risks should not be confused with issues (realized risks). If a root cause is described in the past tense, the root cause has already occurred and is, therefore, an issue that needs to be resolved but not a risk!

**RISK MANAGEMENT PROCESS—DETAILS**

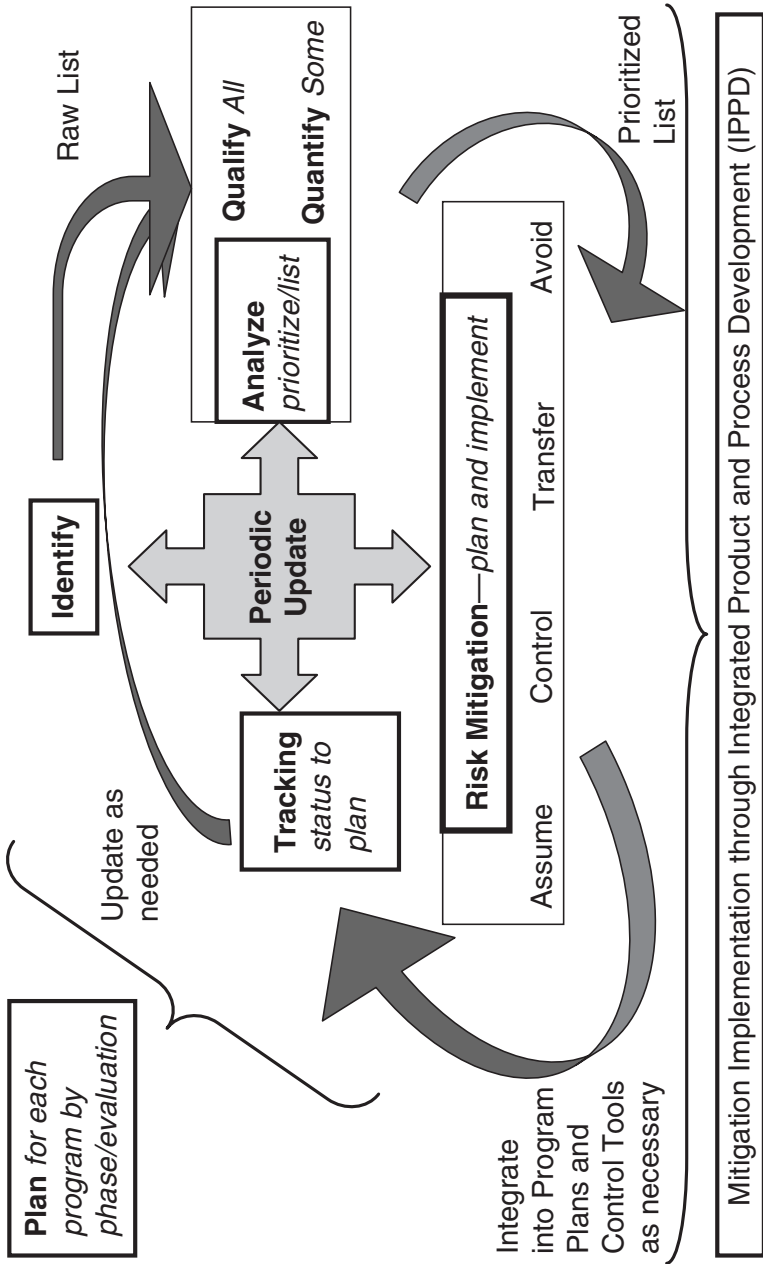

# PROGRAM SUCCESS METRICS MODEL\* SUMMARY

UH-60 MODEL SUMMARY CHART—AN EXAMPLE

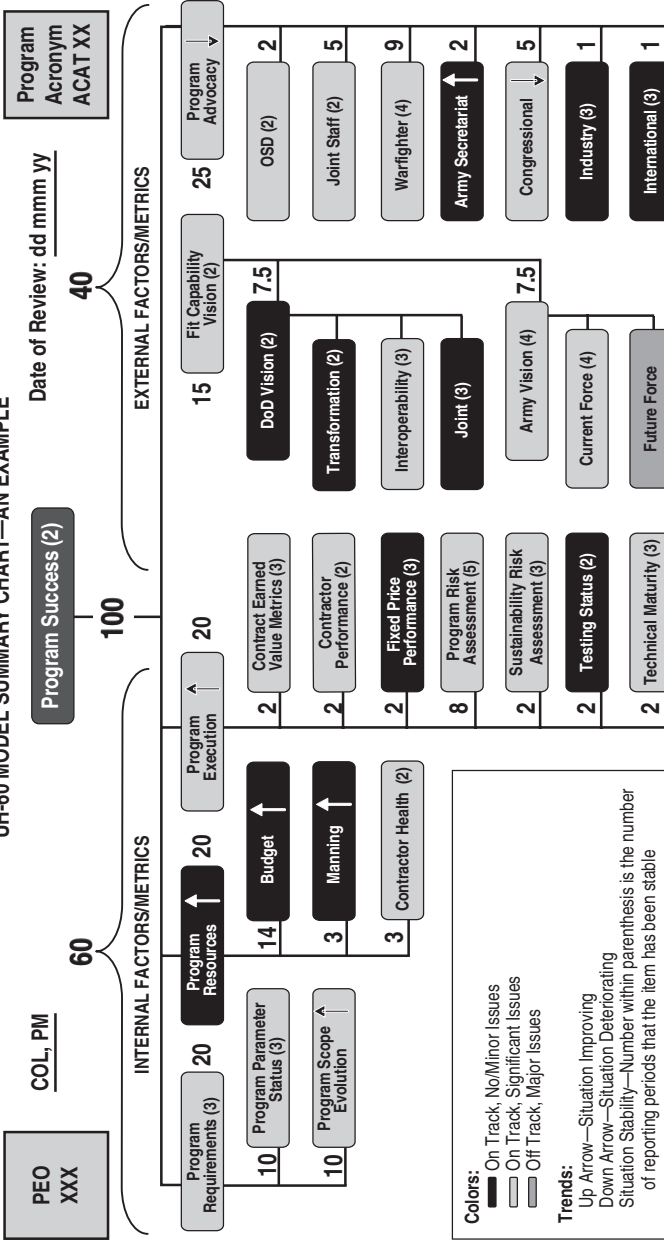

**Program Life Cycle Phase:**

\*Also known as Probability of Program Success (PoPS) Model; initially developed by Mr. John Higbee at the DAU. For more information on PoPS Model, go to <https://acc.dau.mil/CommunityBrowser.aspx?id=24415>.

## WHAT IS SYSTEMS ENGINEERING?

Systems Engineering (SE) is an interdisciplinary approach encompassing the entire technical effort to evolve and verify an integrated and total life cycle balanced set of system, people, and process solutions that satisfy customer needs. SE is the integrating mechanism across the technical efforts related to the development, manufacturing, verification, deployment, operations, support, disposal of, and user training for systems and their life cycle processes; and SE develops technical information to support the program management decision-making process. (DoD definition)

---

## SYSTEMS ENGINEERING PROCESSES

### **DoD SE Technical and Technical Management Processes:**

**Technical Processes:** Stakeholder Requirements Definition, Requirements Analysis, Architecture Design, Implementation, Integration, Verification, Validation, Transition

**Technical Management Processes:** Decision Analysis, Technical Planning, Technical Assessment, Requirements Management, Risk Management, Configuration Management, Technical Data Management, Interface Management

---

## SYSTEMS ENGINEERING POLICY IN DOD

*(DoD 5000.1 and Encl 12, DoDI 5000.02)*

- Manage acquisition programs through the application of a SE approach that optimizes total system performance and minimizes total ownership costs.
- SE Plans (SEPs) are required for each milestone review. SEPs must describe the overall technical approach; key risks, processes, resources, metrics and performance incentives; the timing and content of technical reviews (TRs); and item unique identification (IUID) and reliability, availability, and maintainability (RAM) summaries.
- A lead or chief systems engineer is required at the program executive officer (PEO) level and is responsible to the PEO for effective application of SE processes across the PEO portfolio.
- Called out for special emphasis are:
  - TRs: Event driven and meeting SEP entrance criteria;
  - Configuration management: Required across the life cycle; PM takes control of product baseline after critical design review;
  - Environment, safety and occupational health: Required to be integrated into SE processes;
  - Corrosion prevention, and control: ACAT I programs require formal plan;
  - A modular, open-systems approach shall be employed, where feasible;
  - Data management strategy: Required for all ACAT I and II programs;
  - IUID: An implementation plan is required; and
  - RAM: A strategy is required to include reliability growth program.

# SYSTEMS ENGINEERING PROCESS—TECHNICAL MANAGEMENT PROCESSES

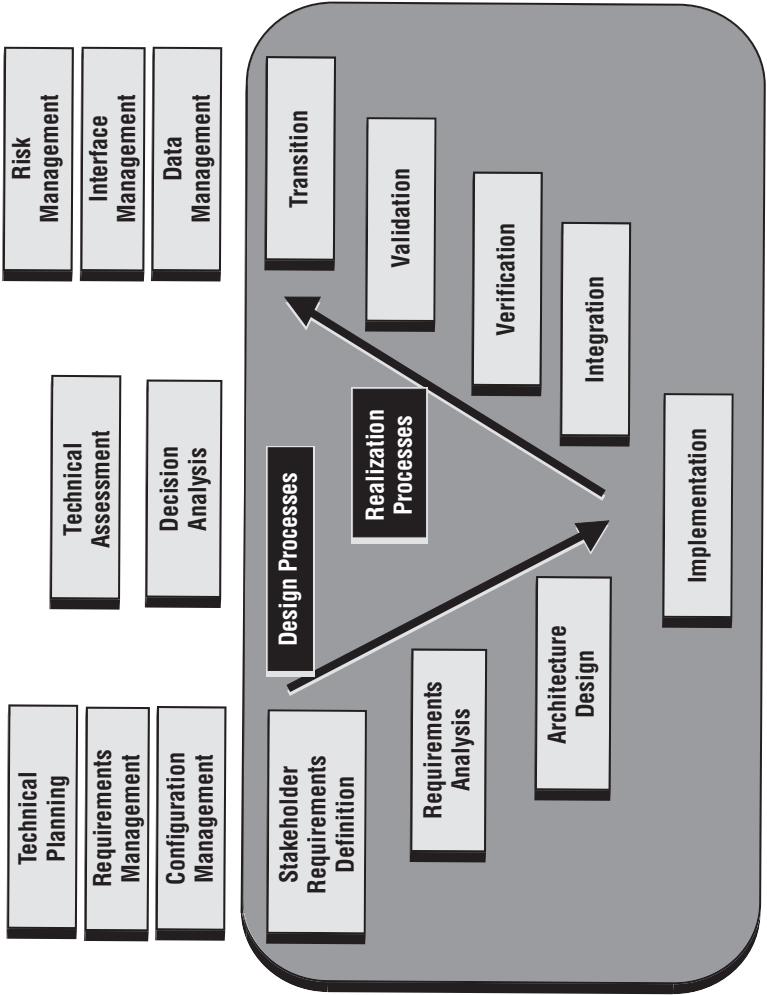

**DEFENSE ACQUISITION MANAGEMENT SYSTEM—TECHNICAL “V” ACTIVITIES**

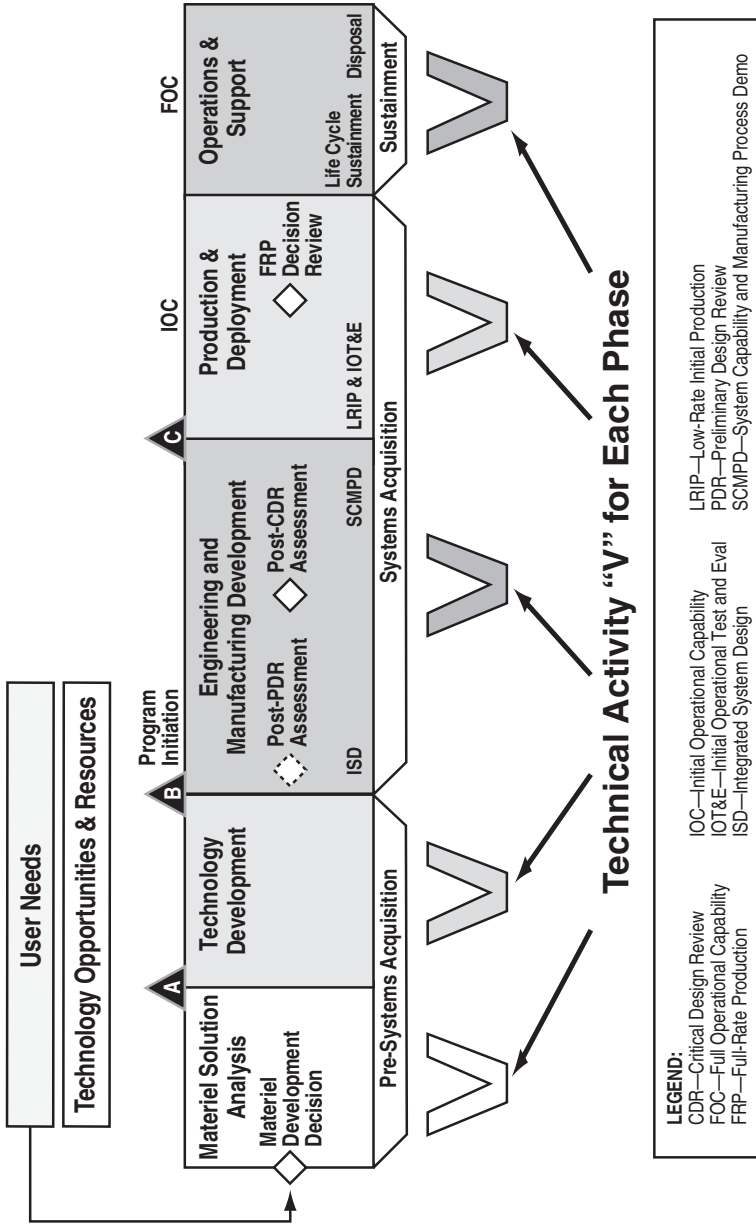

## MATERIEL SOLUTION ANALYSIS PHASE SYSTEMS ENGINEERING (SE) ACTIVITIES

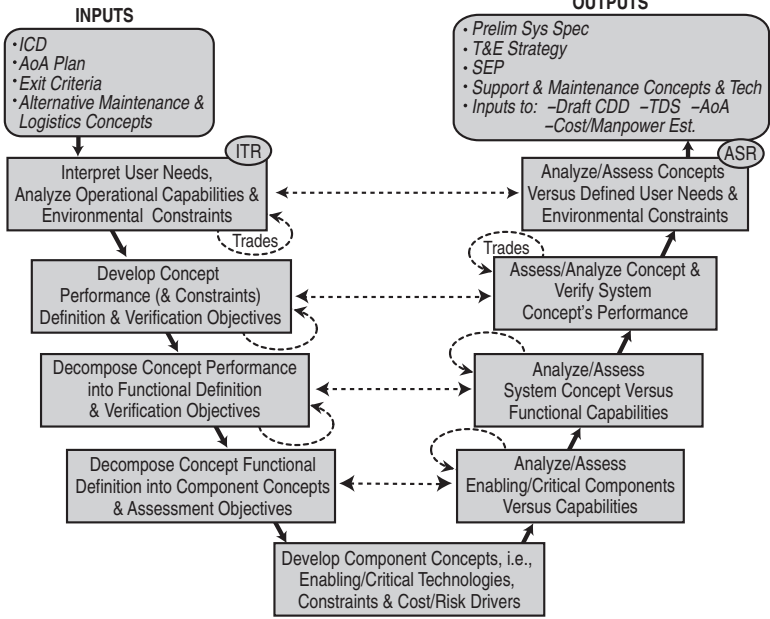

## TECHNOLOGY DEVELOPMENT PHASE SE ACTIVITIES

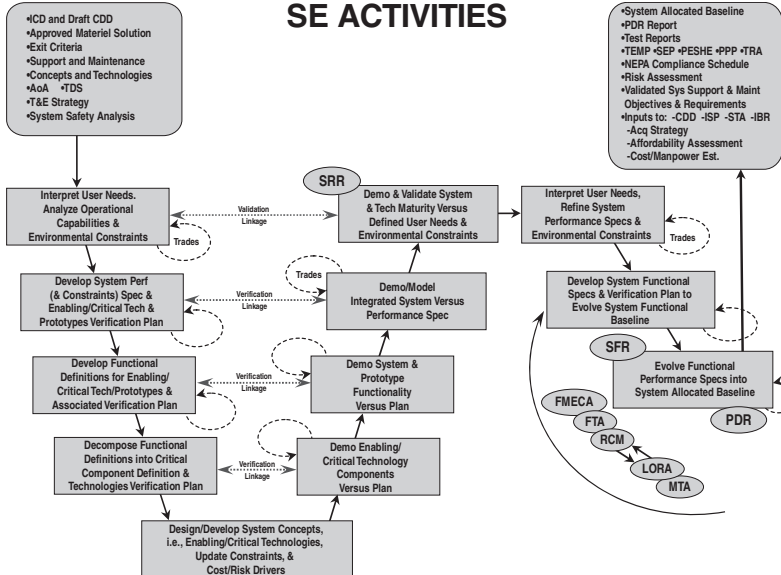

# ENGINEERING AND MANUFACTURING DEVELOPMENT PHASE SE ACTIVITIES

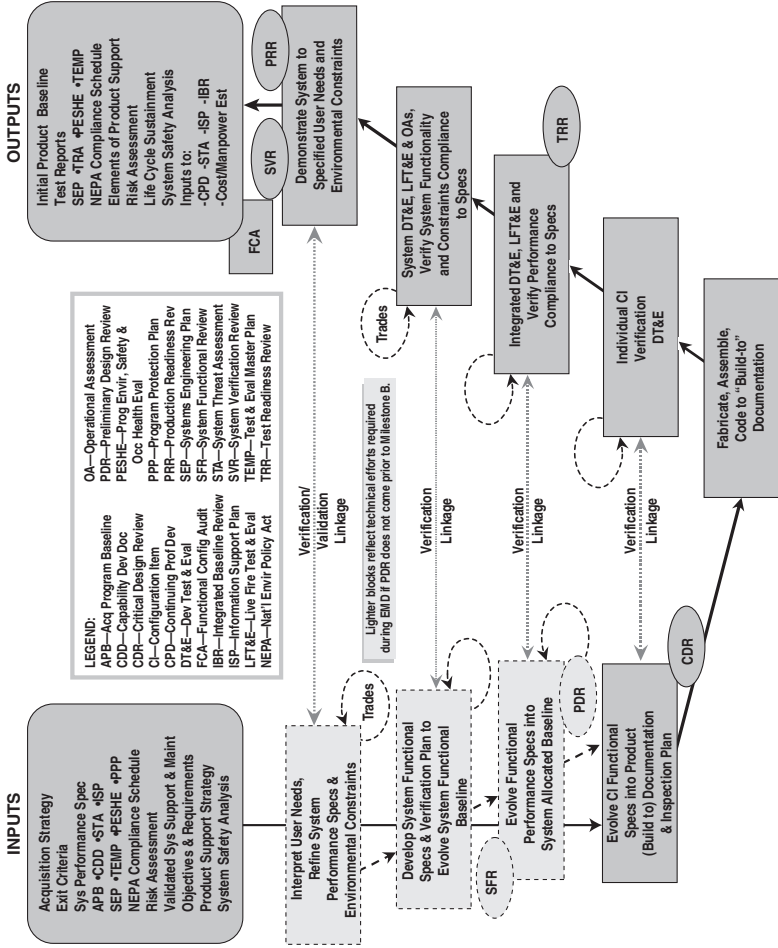



## REQUIREMENTS (USER NEEDS) ANALYSIS QUESTIONS

- What are the reasons behind the system development?
  - What are the customer expectations? How will they measure the performance of the system?
  - Who are the users and how do they intend to use the product?
  - What do the users expect of the product?
  - What are their levels of expertise?
  - With which environmental characteristics must the system comply?
  - What are existing and planned interfaces?
  - What functions will the system perform, expressed in customer language?
  - What are the constraints—hardware, software, economic, procedural—with which the system must comply?
  - What will be the final form of the product—model, prototype, mass production?
- 

## ATTRIBUTES OF A WELL-DEFINED REQUIREMENT

- **Specific, Clear, and Unambiguous:** Contains no vague terms.
- **Understandable:** Stated with sufficient detail in everyday language.
- **Concise:** Contains no unnecessary words.
- **Consistent:** Top-to-bottom consistency with identical usage of terms and conformance to standards.
- **Achievable:** Reflects a need for which a solution is technically feasible at affordable costs.
- **Traceable:** Ultimately traceable back to a higher-level or stakeholder requirement.
- **Verifiable:** Expressed in such a manner so that the requirement can be verified in an objective, preferably quantitative manner.
- **Feasible:** Can achieve, produce, and maintain the requirement.

# SYSTEMS ENGINEERING DESIGN PROCESSES ILLUSTRATED

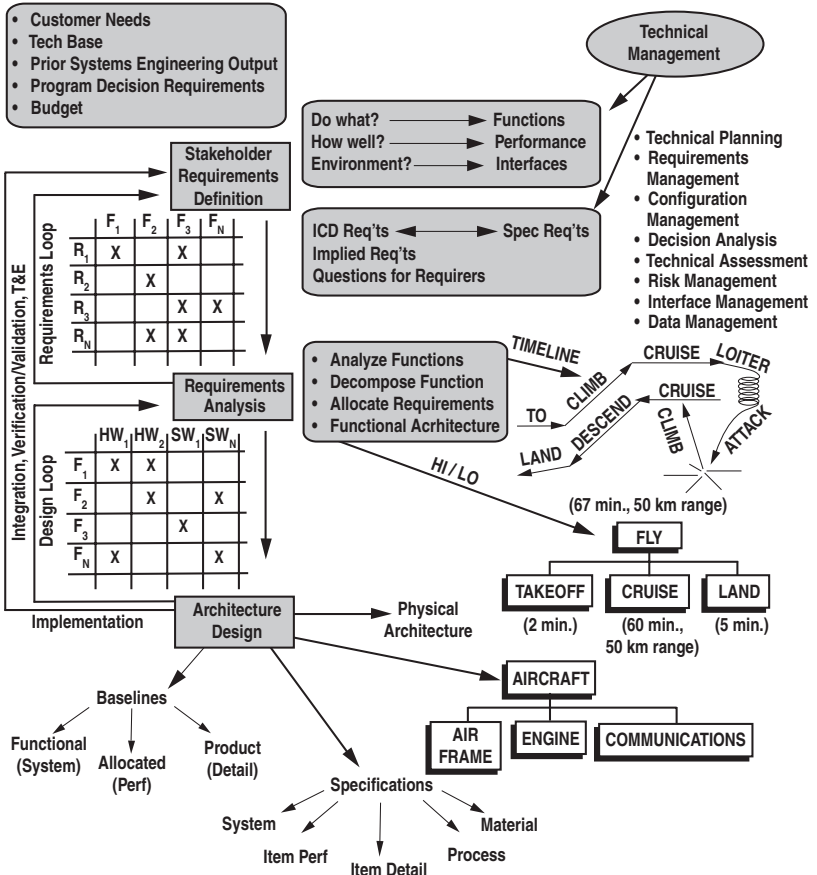

# SPECIFICATION DEVELOPMENT AND TECHNICAL REVIEWS

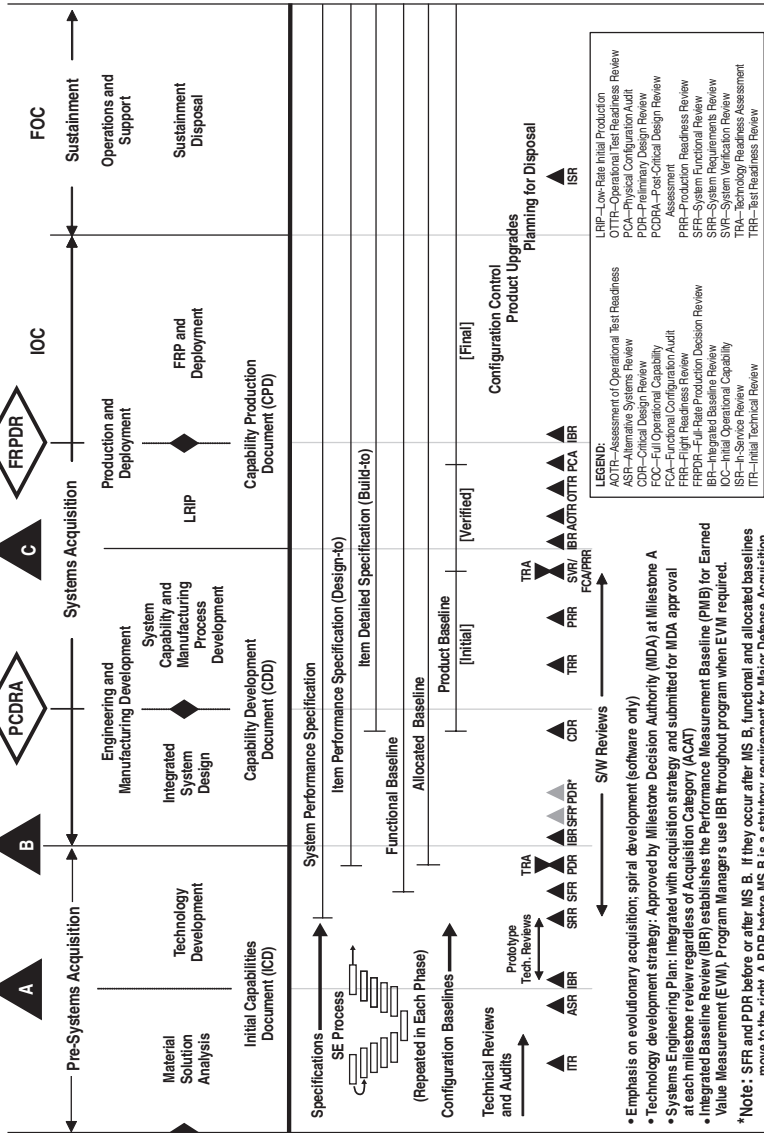

**LEGEND:**

- ▲ ITR—Initial Technical Review
- ▲ ASR—Assessment of Operational Test Readiness
- ▲ SRR—System Requirements Review
- ▲ PDR—Physical Design Review
- ▲ PRR—Production Readiness Review
- ▲ SFR—System Functional Review
- ▲ SRR—System Requirements Review
- ▲ SVR—Service Review
- ▲ ICR—Initial Operational Capability
- ▲ ISR—Initial Technical Review
- ▲ ITR—Initial Technical Review
- ▲ LTRP—Low-Rate Initial Production
- ▲ OTR—Operational Test Readiness Review
- ▲ PCA—Physical Configuration Audit
- ▲ PDR—Primary Design Review
- ▲ PCDA—Pre-Critical Design Review
- ▲ PDR—Production Readiness Review
- ▲ PRR—Production Readiness Review
- ▲ SFR—System Functional Review
- ▲ SRR—System Requirements Review
- ▲ SVR—System Verification Review
- ▲ TRA—Technology Readiness Assessment
- ▲ TRR—Test Readiness Review

- Emphasis on evolutionary acquisition; spiral development (software only)
  - Technology development strategy: Approved by Milestone Decision Authority (MDA) at Milestone A
  - Systems Engineering Plan: Integrated with acquisition strategy and submitted for MDA approval at each milestone review regardless of Acquisition Category (ACAT)
  - Integrated Baseline Review (IBR) establishes the Performance Measurement Baseline (PMB) for Earned Value Measurement (EVM). Program Managers use IBR throughout program when EVM required.
- \*Note:** SFR and PDR before or after MS B. If they occur after MS B, functional and allocated baselines move to the right. A PDR before MS B is a statutory requirement for Major Defense Acquisition Programs (MDAPs).

# SYSTEMS ENGINEERING TECHNICAL MANAGEMENT PROCESSES KEY QUESTIONS



- HOW DO WE ESTABLISH INTEGRATED PLANS FOR THE EFFORT? —————> TECHNICAL PLANNING
- HOW DO WE KNOW WHERE WE ARE IN THE EFFORT? —————> TECHNICAL ASSESSMENT\*
- HOW DO WE ENSURE THE SYSTEM WILL MEET STAKEHOLDER NEEDS? —————> REQUIREMENTS MANAGEMENT
- HOW DO WE AVOID ISSUES IMPACTING DEVELOPMENT? —————> RISK MANAGEMENT
- HOW DO WE IDENTIFY, MANAGE, AND CONTROL TECHNICAL BASELINES? —————> CONFIGURATION MANAGEMENT
- HOW WILL DATA BE AVAILABLE WHEN NEEDED TO SUPPORT THE SYSTEM? —————> TECHNICAL DATA MANAGEMENT
- HOW WILL THE SYSTEM COME TOGETHER MOST EFFECTIVELY? —————> INTERFACE MANAGEMENT
- HOW WILL FORMAL AND INFORMAL TRADEOFFS BE BEST MADE? —————> DECISION ANALYSIS

\*Via Technical Reviews, Earned Value Management, Technical Performance Measurement

## TECHNICAL REVIEW DEFINITIONS

**Alternative Systems Review (ASR):** The ASR assesses the preliminary materiel solutions that have been proposed and selects the one or more proposed materiel solution(s) that ultimately have the best potential to be developed into a cost-effective, affordable, and operationally effective and suitable system at an appropriate level of risk.

**Critical Design Review (CDR):** The CDR establishes the initial product baseline. A successful CDR is predicated on the determination that the subsystem requirements, subsystem detailed designs, results of peer reviews, and plans for test and evaluation form a satisfactory basis for proceeding into system implementation and integration.

**Flight Readiness Review (FRR):** The FRR is a subset of the Test Readiness Review and is applicable only to aviation programs. The FRR assesses the readiness to initiate and conduct flight tests or flight operations.

**Initial Technical Review (ITR):** The ITR is a multi-disciplined technical review held to ensure that a program's technical baseline is sufficiently rigorous to support a valid cost estimate as well as enable an independent assessment of that estimate.

**In-Service Review (ISR):** The ISR is held to ensure that the system under review is operationally employed with well-understood and managed risk. It provides an assessment of risk, readiness, technical status, and trends in a measurable form. These assessments help to substantiate in-service support budget priorities.

**Preliminary Design Review (PDR):** The PDR establishes the allocated baseline (hardware, software, human/support systems). A successful PDR is predicated on the determination that the subsystem requirements; subsystem preliminary design; results of peer reviews; and plans for development, testing, and evaluation form a satisfactory basis for proceeding into detailed design and test procedure development.

**Production Readiness Review (PRR):** The PRR examines a program to determine if the design is ready for production and if the prime contractor and major subcontractors have accomplished adequate production planning. The PRR determines if production or production preparations have unacceptable risks that might breach thresholds of schedule, performance, cost, or other established criteria.

**System Functional Review (SFR):** The SFR is held to ensure that the system's functional baseline has a reasonable expectation of satisfying stakeholder requirements within the currently allocated budget and schedule. The SFR assesses whether the system's proposed functional definition is fully decomposed to its lower level, and that preliminary design can begin.

**System Requirements Review (SRR):** The SRR assesses the system requirements as captured in the system specification and ensures that the system requirements are consistent with the approved materiel solution (including its support concept) as well as available technologies resulting from any prototyping efforts.

**System Verification Review (SVR):** The SVR is held to ensure the system under review can proceed into initial and full-rate production within cost (program budget), schedule (program schedule), risk, and other system constraints. The SVR assesses system functionality and determines if it meets the functional requirements as documented in the functional baseline.

**Test Readiness Review (TRR):** The TRR is designed to ensure that the subsystem or system under review is ready to proceed into formal test. The TRR assesses test objectives, test methods and procedures, scope of tests, and safety; and it confirms that required test resources have been properly identified and coordinated to support planned tests.

## TECHNICAL REVIEW BEST PRACTICES

*Easy in principle,  
difficult in practice.*

### Technical reviews:

- Are a fundamental part of the Systems Engineering Technical Assessment Process for the program manager.
  - Should be event-based;
  - Objective entry and exit criteria need to be defined up front. See the *Defense Acquisition Guidebook* (DAG) for general criteria and the program's Systems Engineering Plan (SEP) for specific criteria;
  - Are only as good as those who conduct them;
  - Engagement of Technical Authority;
  - Chair independent of program, team;
  - Independent subject-matter experts, determined by Chair; and
  - Involve all affected STAKEHOLDERS.
- Should review status of program development from a technical perspective.
  - Involve all affected STAKEHOLDERS; and
  - Involves all technical products (e.g., specifications, baselines, risk assessments, etc.) relevant to the review.
- System-level reviews should occur after the corresponding subsystem level review!

**NOTE:** Check out DAU Continuous Learning Module CLE003 (Technical Reviews), which includes detailed tailored checklists for all key Technical Reviews.

## PROGRAM-UNIQUE SPECIFICATIONS



- Program-unique specifications advantages:
  - Helps **avoid** duplication and inconsistencies.
  - Enables **good** estimates of necessary work and resources.
  - Provides consistent **communication** among players as people rotate.
  - Can be used to **prepare** test plans.
  - Can be used a long time **after** the system has been put into operation.
  - Serves as an **interface** between customers, developers, and designers.
  - Can act as negotiation and reference document for **engineering changes**.

Specification	Content	Baseline
System	<ul style="list-style-type: none"> <li>• Defines mission/technical performance requirements. Allocates requirements to functional areas. Defines interfaces.</li> </ul>	Functional (“System”)
(Hardware or Software) Item Performance	<ul style="list-style-type: none"> <li>• Defines performance characteristics of configuration items (form, fit, function). Details design requirements only to meet interfaces. “DESIGN-TO.”</li> </ul>	Allocated (“Design-to”)
(Hardware or Software) Item Detail	<ul style="list-style-type: none"> <li>• Includes “how to” and specific design requirements. Usually includes specific processes and procedures. “BUILD-TO.”</li> </ul>	Product (“Build-to”)
Process	<ul style="list-style-type: none"> <li>• Defines process performed during fabrication.</li> </ul>	Product
Material	<ul style="list-style-type: none"> <li>• Defines production of raw materials or semi-fabricated material used in fabrication.</li> </ul>	Product

## PERFORMANCE vs. DETAIL SPECIFICATIONS

Two generic categories of program-unique specifications are performance specifications and detail specifications.

- **Performance Specifications:** States requirements in terms of the required results without stating the method for achieving the required results, functional and performance (what and how well), the environment in which product(s) must operate; interface and interchangeability characteristics, and criteria for verifying compliance.
- **Detail Specifications:** Specifies requirements in terms of material to be used; how a requirement is to be achieved; and how a product is to be assembled, integrated, fabricated, or constructed. Applicable to development of contractor final design drawings as well as items being built, coded, purchased, or reused.
- **MIL-STD 961:** Defense and program-unique specifications format and content establishes the format and content requirements for defense specifications and program-unique specifications prepared either by DoD activities or by contractors for the DoD.

	<b>PERFORMANCE</b>	<b>DETAIL / DESIGN</b>
Design/Fab.	Require desired outcomes or functions; specific design to contractor	Specify exact parts and components
Processes	Few, if any	Specify exact processes
Physical Characteristics	Give specifics only for interfaces, environment, or human factors	Specify more physical characteristics than for interfaces, environment, etc.
Interface Requirements	Detailed interface data do NOT solely make a perf. spec. a detail spec.	Detailed interface data
Materials	Leave specifics to contractor	Require specific materials
Test and Evaluation	State performance need; contractor picks test procedure	Prescribed testing process

## **CONFIGURATION MANAGEMENT**

*(Defense Acquisition Guidebook, MIL-HDBK-61A and ANSI/EIA Standard 649A)*

**“A management process for establishing and maintaining consistency of a product’s performance, functional, and physical attributes with its requirements, design, and operational information throughout its life.”**

- **Identify** and **document** the functional and physical characteristics of configuration items.
- **Change Management: control** changes to configuration items and their related documentation.
- **Record (Status Accounting)** and report information needed to manage configuration items effectively, including the status of proposed changes and implementation status of approved changes.
- **Verification and Audit of configuration items to verify** conformance to specifications, drawings, interface control documents, and other contract requirements.

### ***CONFIGURATION MANAGEMENT PLANNING***

- The decisions on
    - **Which baselines the Government should eventually control**
    - **The data needed**
    - **When that control should be established**
- ... are strategic management decisions that involve
- **Acquisition strategies—sources, competition, etc.**
  - **Logistics support plans—repair levels, data needs, open systems, etc.**
  - **Technology insertion—stable vs. rapidly moving technologies, etc.**
- Government should control the Functional Baseline (document system level requirements)
  - By DoD policy, at the completion of the system level Critical Design Review (CDR), the PM shall assume control of the initial product baseline for all Class 1 configuration changes.

## INTERFACE MANAGEMENT

Will it all work together?

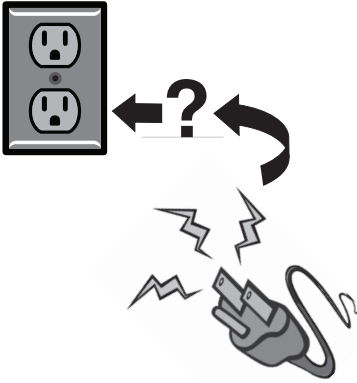

- The government PMO:
  - Identifies external interfaces
  - Establishes interface standards (baselines)
  - Maintains interface stability
- The contractor:
  - Manages internal interfaces
  - Establishes interface requirements to include internal and external interfaces
  - Controls interfaces to ensure
    - ◆ Accountability
    - ◆ Timely dissemination of changes

*Since they are not under direct contractor control, the government plays a big role in managing external interfaces, leaving management and design details of internal system interfaces to the contractor.*

---

## INTERFACE CONTROL CONCEPT

- Identifies, documents, and controls all functional and physical characteristics
- Interfaces:
  - What?
    - ◆ Common boundary
    - ◆ Types: mechanical, electrical, operational, software
    - ◆ Functional and physical characteristics
  - Where?
    - ◆ Within one contractor's design
    - ◆ Among contractor's items and GFE
    - ◆ Among multiple contractors' items
    - ◆ Among systems
  - Controlled by Interface Control Working Group
  - Documented in Interface Control Documents

## WORK BREAKDOWN STRUCTURE (WBS)

A WBS:

- Is a product-oriented family tree composed of hardware, software, services, data, and facilities.
- Provides a consistent and visible framework for defense materiel items and contracts within a program.
- Is an organized method to breakdown the system structure of a product into subproducts at lower levels of detail.
- Can be expressed down to any level of interest. Generally, the top three levels are sufficient unless the items identified are high cost or high risk. If so, then it is important to take the WBS to a lower level of definition.
- Key types of a WBS are a Program WBS and a Contract WBS
  - **Program WBS:** encompasses an entire program, including the Contract WBS and “other government” elements (e.g., Program Office Operations, Manpower, GFE, government Testing). It defines at a high level what is to be procured and consists of at least three program levels with associated definitions.
  - **Contract WBS:** the complete WBS as extended to the agreed-to contract reporting level. It defines the lower level components of what is to be procured and includes all the product elements (hardware, software, data, or services), which are defined by the contractor and are their responsibility.
- MIL-HDBK-881A (Work Breakdown Structures for Defense Materiel Items) should be consulted for developing Program and Contract WBS. It provides details on various types of defense systems as well as elements common to all defense systems.
  - **MIL-HDBK-881A Defense Systems:** Aircraft Systems, Electronic/Automated Software Systems, Missile Systems, Ordnance Systems, Sea Systems, Space Systems, Surface Vehicle Systems, and Unmanned Air Vehicle Systems.
  - **MIL-HDBK-881A Common Elements:** integration, assembly, test, and checkout, Systems Engineering, Program Management, training, data, System Test and Evaluation, peculiar and common support equipment, operational and site activation, industrial facilities, and initial spares and repair parts.

## HOW TO CREATE A WORK BREAKDOWN STRUCTURE (WBS)

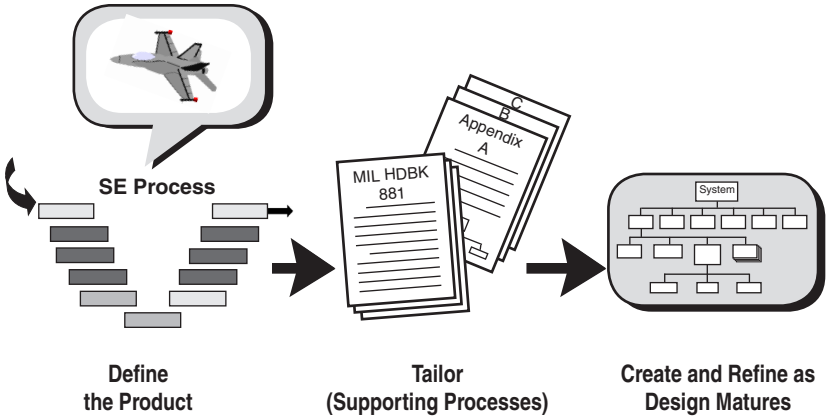

## BASIC PURPOSES OF WBS

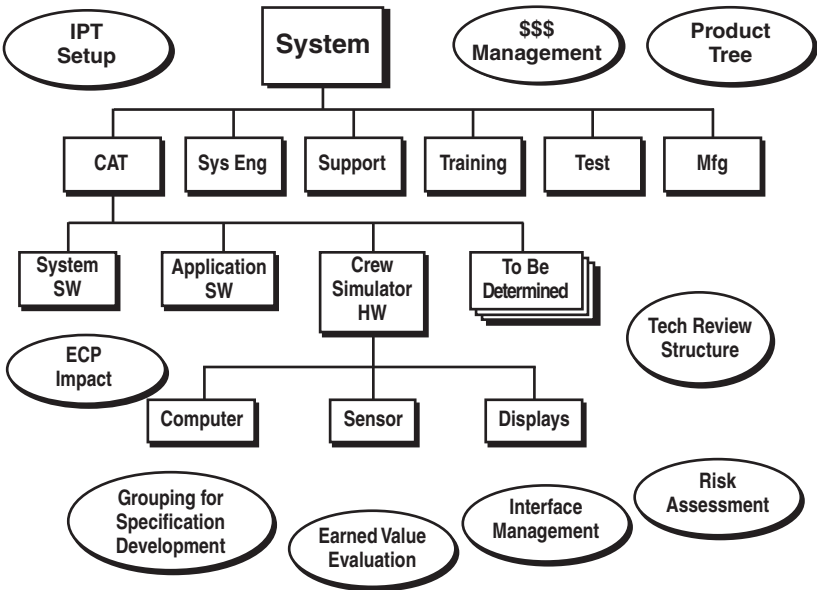

NOTE: Oval shapes on periphery identify WBS purposes

# SOFTWARE DEVELOPMENT—TECHNICAL REVIEW RELATIONSHIPS

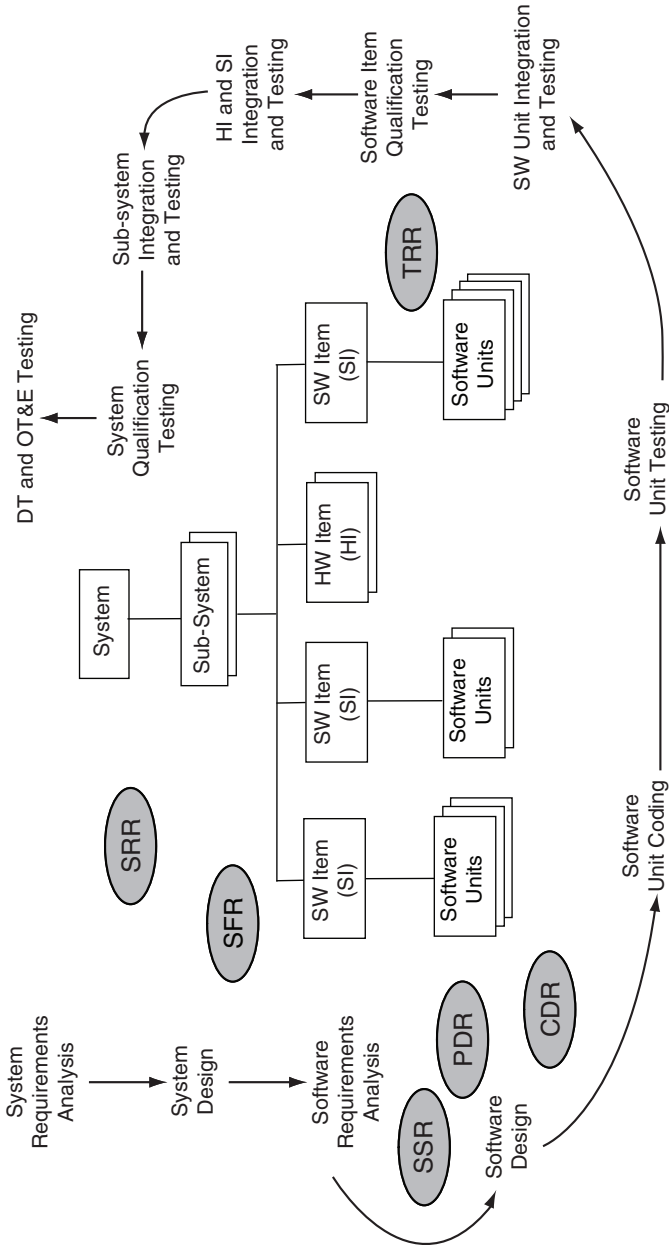

**NOTE:** SSR—Software Specification Review. The SSR is a unique sub-system review held to assess SW requirements prior to start of design.

**SOFTWARE DEVELOPMENT—KEY LIFE CYCLE REVIEW FACTORS**

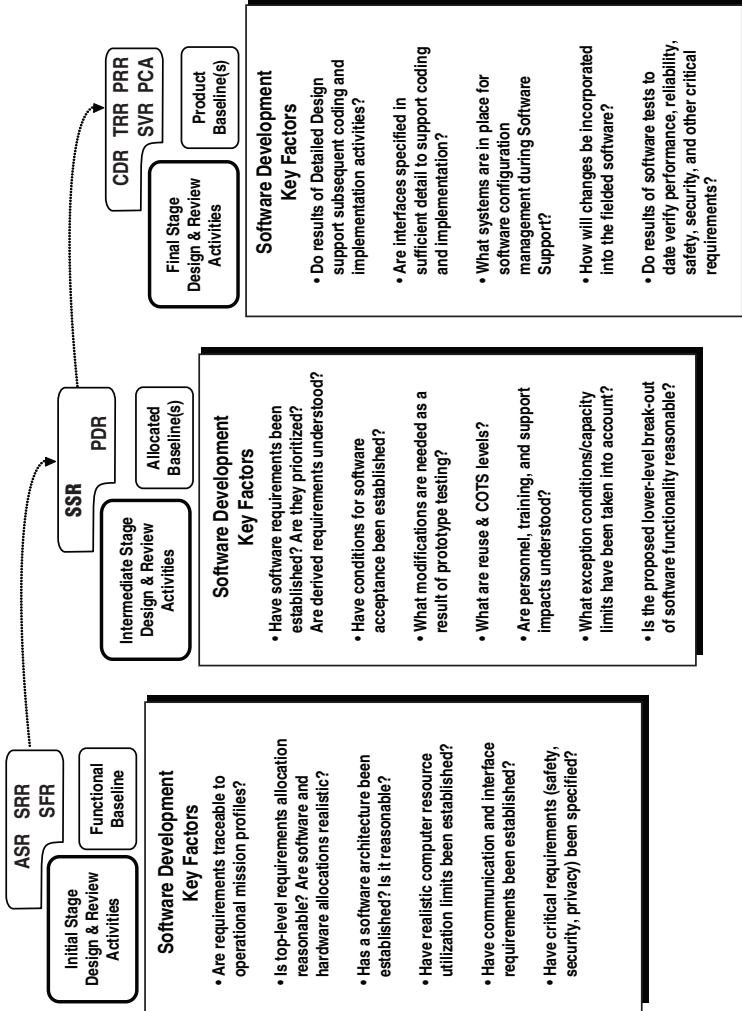

Rev 3.1

## CANDIDATE SOFTWARE MEASURES (METRICS)

- Software Size
- Requirements Volatility
- Software Effort/Staffing
- Software Progress
- Problem/Change Report Status
- Rework/Scrap
- Computer Resource Utilization
- Milestone Performance
- Build/Release Content
- Software Complexity
- Effect of Reuse
- Earned Value

Software measures should be risk- or issue-driven and are phase-dependent.

Check out the handbooks at the “DoD’s Practical System and Software Measures” site at <[www.psmc.com](http://www.psmc.com)>.

## QUALITY EVENTS FOR SOFTWARE

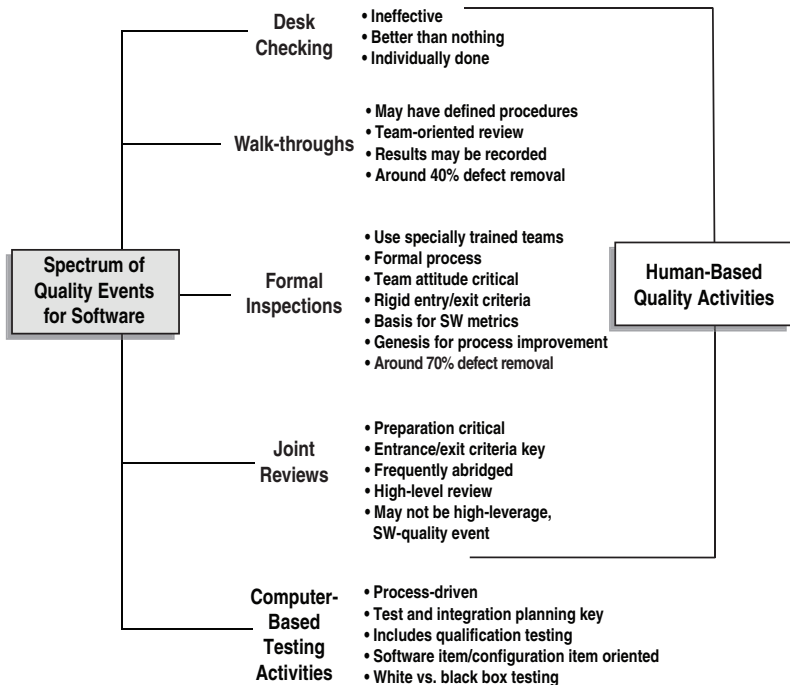

## **SOFTWARE MANAGEMENT BEST PRACTICES**

- Adopt continuous risk management
  - Estimate cost and schedule empirically
  - Use software metrics to help manage
  - Track earned value
  - Track software defects against software quality targets
  - Treat people as the most important resource
  - Use life cycle configuration management
  - Manage and trace requirements
  - Use system-based software design
  - Ensure data and database interoperability
  - Define and control interfaces
  - Design twice, but code once
  - Carefully assess reuse risks and costs
  - Inspect requirements and design
  - Manage testing as a continuous process
  - Test frequently
  - Use good systems engineering processes
- 

## **SOFTWARE ACQUISITION WORST PRACTICES**

- Use schedule compression to justify new technology on a time-critical project
- Have the government mandate technological solutions
- Specify implementation technology in the RFP
- Use as many “silver bullets” as possible
- Expect to recover more than 10% schedule slip without a reduction in delivered functionality
- Put items out of project control on the critical path
- Plan on achieving more than 10% improvement from observed past performance
- Bury as much of the project complexity as possible in the software as opposed to the hardware
- Conduct critical system engineering tasks without software expertise
- Believe that formal reviews alone will provide an accurate picture of the project
- Expect that the productivity of a formal review is directly proportional to the number of attendees above five

## CHAPTER 2 LEADERSHIP AND MANAGERIAL SKILLS

- More things that make you go “Hmmm?...”
  - “An authority is a person who just happens to know the source.”
  - “A conservative is a person who believes nothing should be done the first time.”
  - “Diplomacy is the art of hearing all parties arguing in a dispute and nodding to all of them without ever agreeing with any of them.”
  - “The meeting raised our confidence that the contractor can actually accomplish the task and that it will occur in our lifetime.”
  - “This is the earliest I’ve been late.”
  - “The world would be a much better place if people weren’t allowed to have children until they’ve proven they can successfully manage a DoD program.”
  - “Everyone is bound to bear patiently the results of his/her own example.”
  - “The superior person is firm in the right way, and not merely firm.”

### MANAGEMENT AND LEADERSHIP

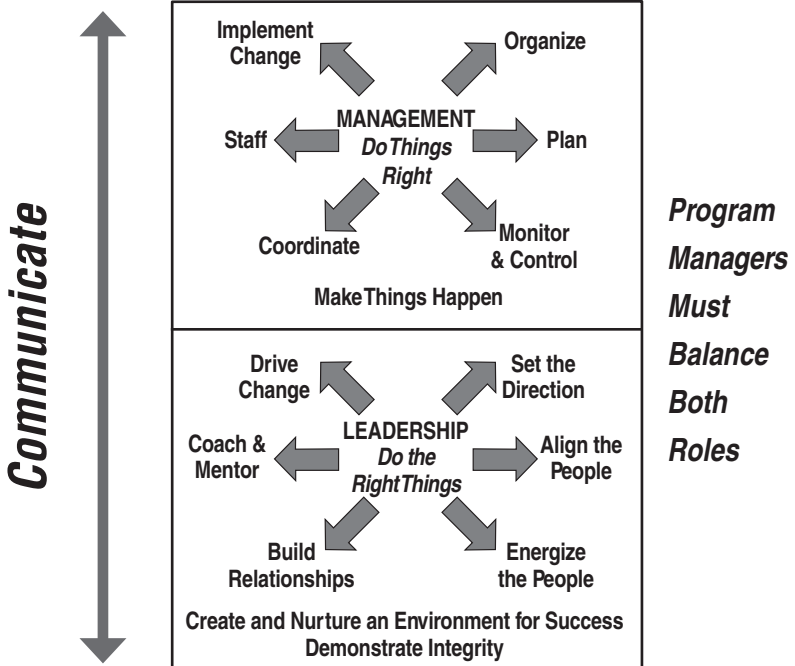

## PROGRAM MANAGEMENT “DIAMOND CARD”

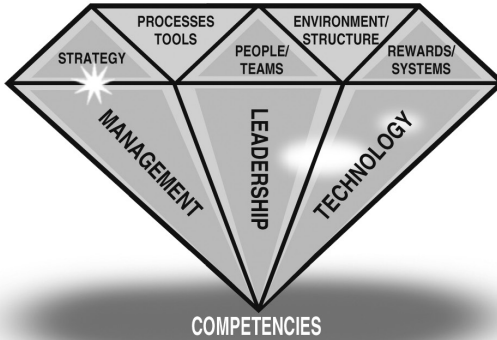

Designed by Al Moseley, DAU SPM

---

### MANAGEMENT

- Logistics
- Production
- Contracting
- Requirements
- Cost Estimating
- Processes/Tools
- Systems Engineering
- Senior Steering Groups
- Test & Evaluation Management
- Risk/Funds/Software Management

---

### LEADERSHIP

- Vision
- Ethnics/Values
- Teambuilding
- Communication
- Leading Change
- Strategic Thinking
- Time Management
- Organization Design
- Expectation Management
- Goals
- Strategy
- Rewards
- Partners
- Customers
- Environment
- Stakeholders
- Teams/People
- Relationship Building

**PROGRAM MANAGEMENT DIAMOND CARD** (Continued)

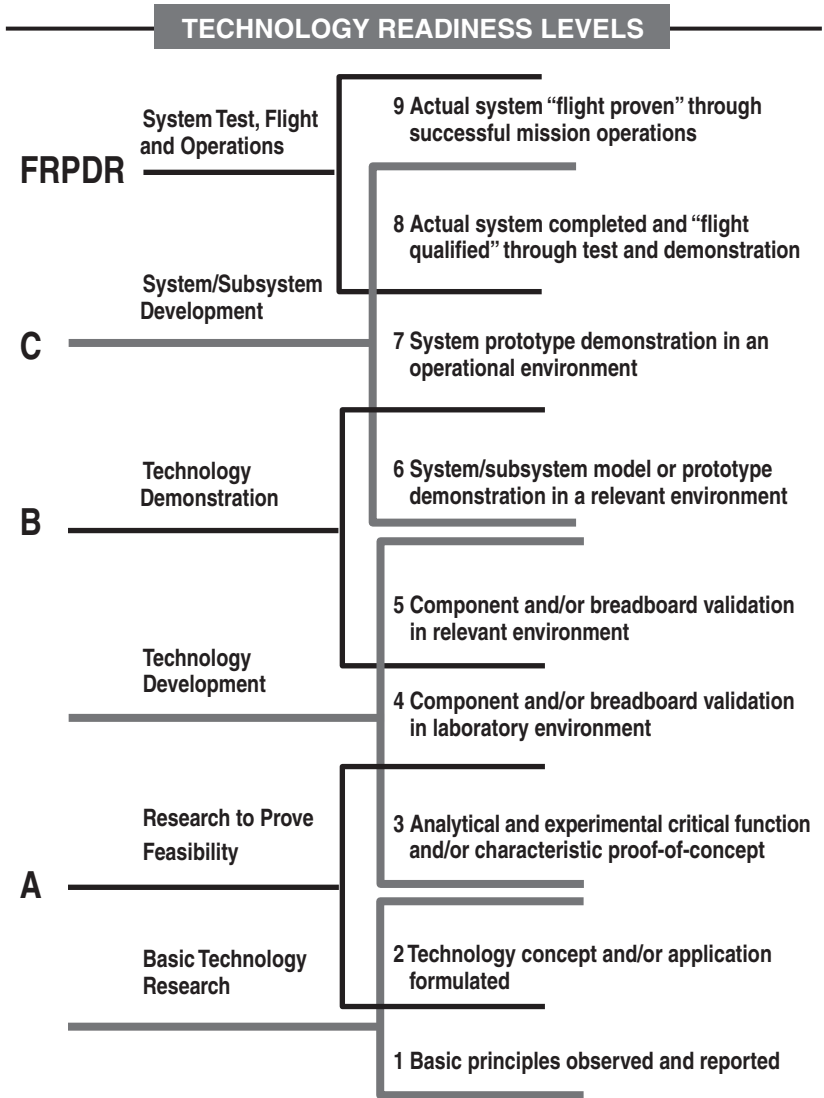

**NOTE:** Technology Readiness Levels (TRL) enable consistent, uniform, discussions of technical maturity across different types of technologies. Decision authorities will consider the recommended TRLs when assessing program risk. TRLs are a measure of technical maturity. They do not discuss the probability of occurrence (i.e., the likelihood of attaining required maturity) or the impact of not achieving technology maturity. (Defense Acquisition Guidebook, Chapter 10)

## EMPOWERMENT, DELEGATION, AND COACHING

EMPOWERMENT	DELEGATION	COACHING
Assigning an employee or team responsibility and authority to take actions and make decisions in pursuit of the organization's goals.	Assigning an employee (usually a subordinate) a specific task or tasks to complete.	Providing employees with the tools, knowledge, and opportunities they need to develop their potential and increase their effectiveness.

### Reasons for Empowerment, Delegation, and Coaching

- Allows managers more time for managerial and leadership roles (e.g., long-term planning, coordinating ongoing activities, monitoring and controlling activities, and providing feedback to employees)
- Increases employee capability and motivation
- Enhances employee career growth
- Improves teamwork
- Maximizes limited resources
- Pushes responsibility and accountability further down in the organization

### Steps for Empowerment, Delegation, and Coaching

1. Select the task or tasks to be assigned
2. Select the person or team; evaluate their current capabilities to complete the task or tasks
3. Provide training and/or coaching, if necessary, to improve their capabilities
4. Solicit input from the person or team regarding the task or tasks
5. Agree on the tasks, objectives, responsibility, authority, and deadline
6. Provide guidance, assistance, and support, as necessary
7. Establish metrics to measure progress
8. Monitor progress
9. Provide feedback
10. Identify lessons learned
11. Evaluate performance

**NOTE:** Some people use “empowerment” and “delegation” interchangeably, while others see a subtle distinction, e.g., delegation often refers to an individual, while empowerment is usually associated with groups or teams. Empowerment usually includes more authority and freedom related to making decisions, and taking actions while delegation is usually more bounded.

## EMPOWERMENT, DELEGATION, AND COACHING

(Continued)

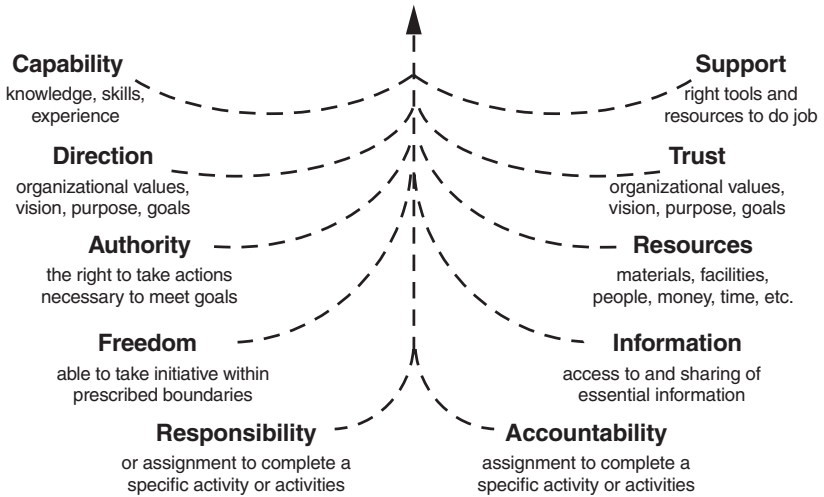

Leaders should ensure the components shown above are present.

## COACHING SKILLS



- **Active Listening.** Give your *full attention*. Focus on the message, not formulating your response to it. Establish and maintain eye contact, paraphrase key points, and avoid making judgments.
- **Questioning.** Ask questions to promote discovery of new knowledge and stimulate thinking. Use open questions that require some thought to complete.
- **Giving Feedback.** This is one of the most valuable yet least used tools in communication. People are often uncomfortable giving feedback to others, particularly when they believe it could be perceived as negative. Offer factual, specific, but non-judgmental (and unemotional) feedback.
- **Sharing.** Share your experiences. Make suggestions on overcoming difficulties or how to proceed.

## GENERIC INTEGRATED PRODUCT TEAM (IPT) PROCESS

**Identify the  
Need for  
an IPT**



**Conduct Team  
Closeout  
Activities**



**Staff the  
Team**



**Assess and  
Realign**



**Conduct  
Team Startup  
Activities**



**Develop a  
Plan of Action**

**Execute  
the Plan**



**Identify a Need for an IPT**—Determine whether the creation of a team is the best method to accomplish the intended purpose.

**Staff the Team**—Determine what functional disciplines and organizations/activities need to be represented and who the team members will be.

**Conduct Team Startup Activities**—Conduct activities to get the team started, such as establishing operating agreements, assigning roles and responsibilities, and conducting team training sessions. Activities also include discussing and agreeing on the team's intended purpose and developing shared goals, critical success factors, and metrics to measure team progress toward goals. A common output of these activities is the Team Charter. (See page 108.)

**Develop a Plan of Action**—Take specific action steps or processes for how the team will perform. This includes assigning action items, establishing target dates, determining what resources are needed, etc.

**Execute the Plan**—Perform the work necessary to accomplish the project goals and produce the team deliverables.

**Assess and Realign**—Conduct periodic assessments of team performance and use metrics to measure progress toward goals. Make adjustments as necessary.

**Conduct Team Closeout Activities**—Deliver the final product or service, update program documents, and compile lessons learned.

# FORMULA FOR EFFECTIVE TEAM PERFORMANCE

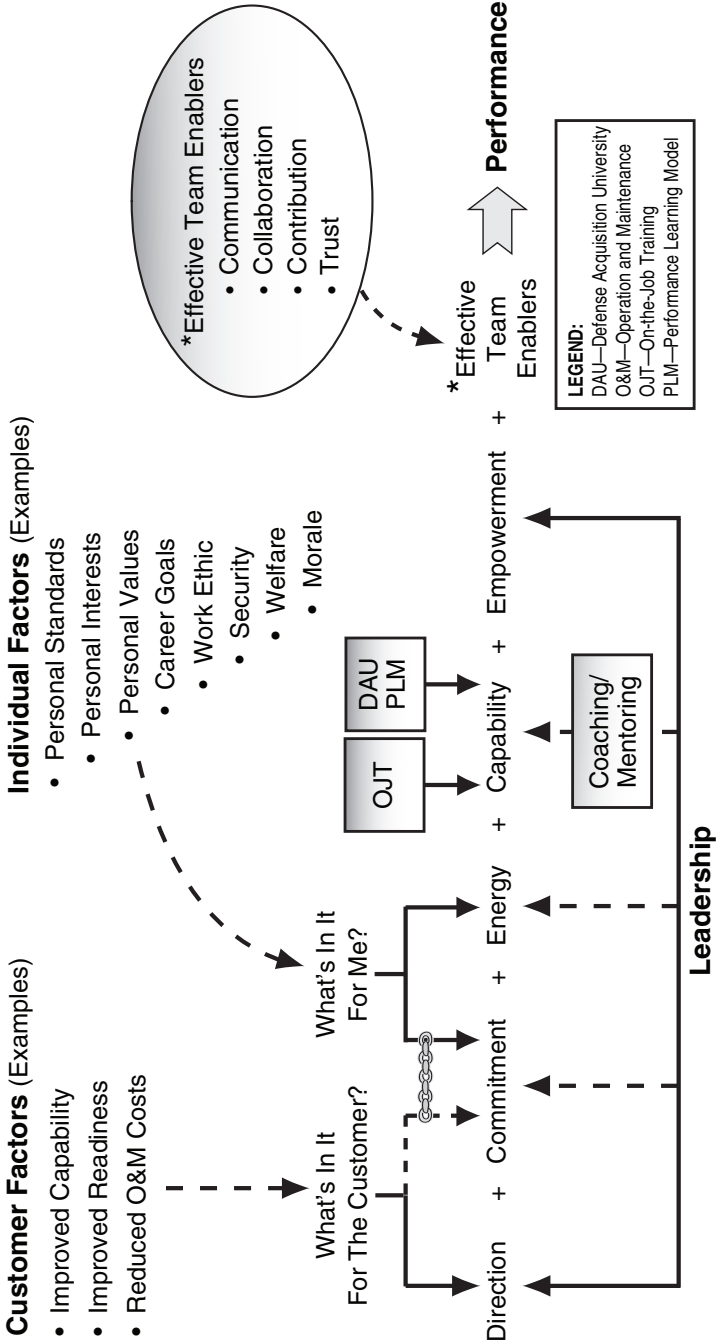

## TEAM CHARTER

**Team Charter.** A document describing key aspects of why a team is established, what is expected of it, and what authority and responsibility it has. The person or entity creating (i.e., “chartering” or authorizing) the team normally provides some general guidance; however, the team may benefit considerably by developing the “meat and potatoes” of the charter, resulting in increased commitment of all team members. Examples of topics that may be included in a charter follow:

- **Purpose.** Describe *why* the team exists and *what* it is intended to accomplish.
- **Goals/objectives.** List specific, measurable items the team is focused on achieving to help it *exceed* its customer’s expectations.
- **Critical success factors.** List the *critical actions* the team must perform to ensure it is successful in fulfilling its purpose.
- **End products/deliverables.** Describe the item(s) the team is responsible for delivering.
- **Authority and accountability.** Describe what team members are allowed/not allowed to do without authorization from a higher level. Describe what they are responsible for completing.
- **Metrics.** List measures of progress for critical success factors and goals/objectives.
- **Program schedule.** List key program/team milestones and events.
- **Team membership.** List team members and contact information.
- **Roles and responsibilities.** List specific assignments for improving team performance (e.g., timekeeper, recorder or scribe, scheduler, etc.). Also, list specific tasks and/or action items the team is assigned to complete.
- **Resources required.** Describe the funding, materials, equipment, support, etc., the team needs to complete its mission.
- **Program organizational structure.** Define where the team fits within the overall program office structure.
- **Program organizational structure.** Describe or depict where the team fits in the overall program office structure.
- **Operating agreements/ground rules.** List agreed-upon guidelines describing how team members will interact, what processes they will use, and what they expect of one another.
- **Customers, suppliers, and stakeholders.** List key individuals, teams, and organizations involved with the team’s output.

## WORKING GROUPS

### Team Development Wheel

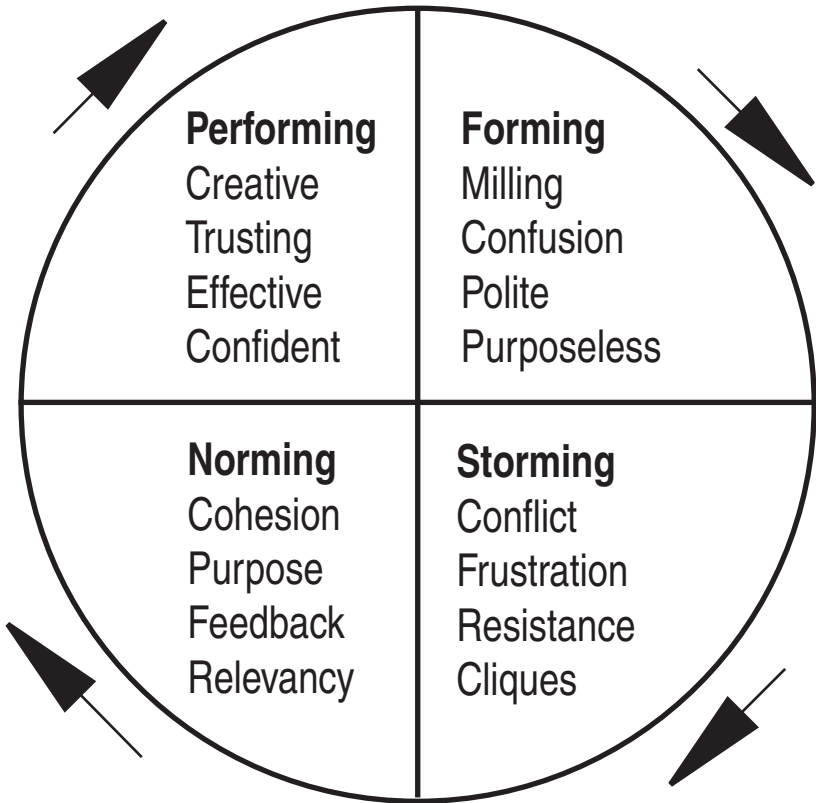

RECOGNIZE WHICH PHASE OF TEAM DEVELOPMENT YOU ARE IN AND TAKE POSITIVE ACTION TO WORK THROUGH.

**NOTE:** There can be an additional phase—"Adjourning"—when the team disbands, says good bye, and reflects on lessons learned. This is a "celebration" phase.

This diagram is based on Dr. Bruce Tuckman's 1965 study of small groups, which identified the traditional five phases experienced by project work teams.

## Typical Working Groups

- Logistics Support Management Team (LSMT)
- Test and Evaluation Working Group (TEWG)
- Computer Resources Working Group (CRWG)
- Requirements Interface Working Group
- Interface Control Working Group (ICWG)
- Technology Assessment Working Group
- “Tiger” Team
- Process Action Team (PAT)
- Integrated Product and Process Teams (IPPTs)

## Management Tradeoffs for Working Groups

### *Advantages*

- More ideas and solutions
- Consensus positions
- Strong commitments

### *Disadvantages*

- Takes more time
- Hard to terminate
- Paralysis by analysis

## TEAM PERFORMANCE MODEL

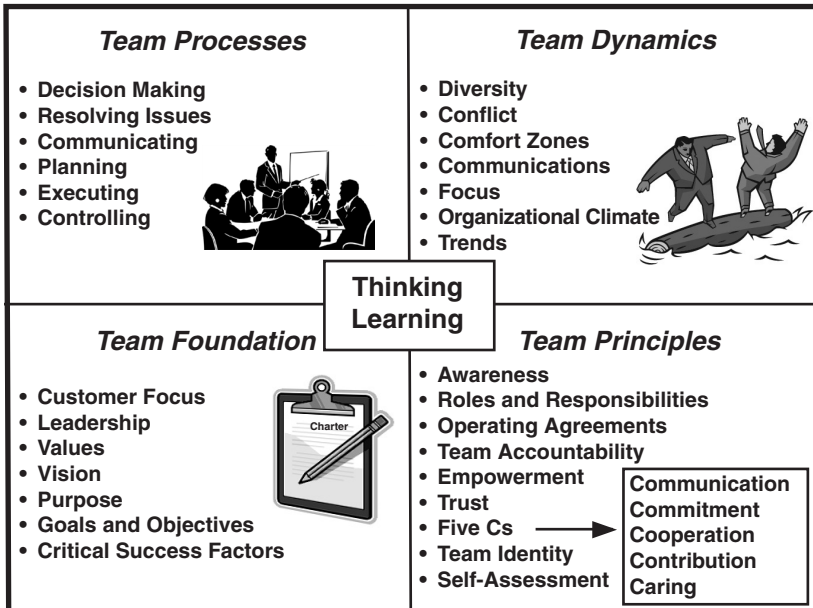

## TEAM DECISION MAKING

Good team decision making is a critical element of team performance. It involves examining the decision context (e.g., current program environment, assumptions, constraints, pressures, stakeholder inputs, etc.), determining who needs to be involved in the decision, verifying how much time is available to make the decision, and deciding on the decision-making process.

### Generally Accepted Team Decision-Making Methods

- **Unilateral.** One person makes the decision, usually the team leader.

Variations:

- *Directive or Authoritative.* The person making the decision does so primarily using his/her knowledge, experience, and program guidelines/constraints, but is also influenced by his/her own reasons and motives.
- *Consultative.* The person making the decision may seek input from other team members, but ultimately, he/she still makes the decision on his/her own.

- **Majority.** Each team member votes, and the majority decides the course of action.

- **Consensus.** Team members may not completely agree with the most preferred approach, but they have the opportunity to express their point of view, understand the logic behind the decision, and support it. Consensus is generally the preferred decision-making method for most team issues, especially when the commitment of all team members is important.

### Guidelines for Achieving Consensus:



- Don't try to force consensus. Listen to other positions and reactions before expressing your own point.



- No winners or losers. Don't assume that someone must "win" and someone must "lose" if the discussion reaches a stalemate.



- Don't avoid conflict. Don't change your mind simply to reach agreement and maintain harmony.



- Avoid majority votes, compromises, or horse trading to reach an agreement.



- It's OK to disagree. Differences of opinion are natural and expected.

**NOTE: Groupthink.** A phenomenon—to be avoided—where team members become so concerned about preventing disagreement or conflict that they abandon critical thinking to simply go along with whatever consensus seems to be emerging.

## EFFECTIVE MEETINGS

### Prior to the Meeting

- Determine and clarify the purpose for the meeting
- Determine expected meeting outcomes
- Identify meeting attendees
  - Subject-matter experts
  - Key decision makers
  - People directly affected by potential decisions/outcomes
- Determine meeting format
  - Face-to-face, virtual teleconference, teleconference, Web tool
- Determine date/time/location
- Develop and distribute meeting agenda (at least 24 hours prior)
  - Specific topics, presenter, estimated time, desired outcome
- Meeting logistics
  - Room setup, IT support needed

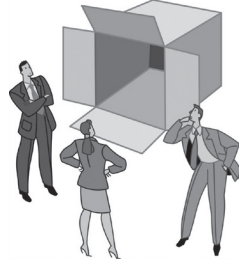

### During the Meeting

- Opening
  - Start on time
  - Review agenda
  - Set or review ground rules
  - Clarify roles
- Conducting
  - Address one item at a time
  - Facilitate discussions
  - Encourage open communication and information sharing
  - Maintain focus and pace
  - Specify topics, presenter, amount of time devoted to item
- Closing
  - Summarize agreements and decisions
  - Review action items
  - Ask for agenda items for the next meeting
  - Set the date/time of the next meeting



### After the Meeting

Review and publish minutes

## DECISION BRIEFING

### Elements of a Decision Briefing

- Outline—Agenda
- Purpose of Briefing/Issue(s)
- Background
- Assumptions
- Alternatives Identified
- Evaluation Criteria/Process
- Analysis of Identified Alternatives
- Recommended Alternative
- Rationale for Recommendation
- Recommended Implementation Plan
- Key Risks for Recommended Implementation Plan



### What to Expect from the Person/People Receiving the Briefing

- Challenges to assumptions, definitions, methodology
- Questions concerning compliance with or changes to policy
- Sensitivity of the issue and/or recommended alternative to change
- Questions or challenges to analysis, tradeoffs, rationale for recommendations, and implementation plan
- Questions concerning risks for the recommended implementation plan



**NOTE:** Questions may be open-ended or closed (e.g., yes/no answers).

## COMMUNICATIONS

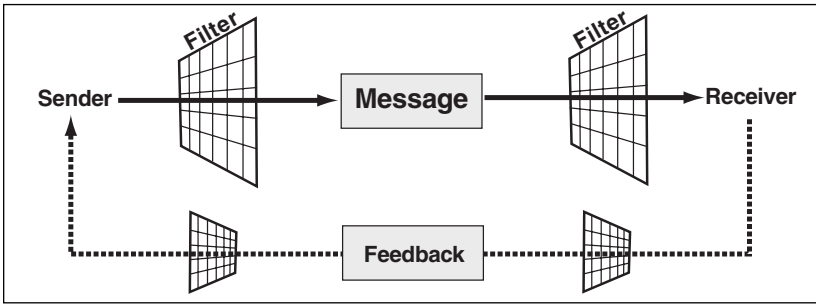

Messages pass through filters; first through the filter of the person sending the message and then through the filter of the receiver. Filters sometimes act to enhance the message, and at other times, they can be barriers. Filters consist of factors such as personality, tone of voice, body language, facial expressions, accents, perceptions, attitudes, emotions, knowledge, functional background, the medium of communication used (verbal, written, e-mail, etc.) and much more. Each person’s filter is different, sometimes resulting in the receiver interpreting the message differently than the sender intended.

One of the most important communications skills (and often a barrier to effective communications) is listening. Learning to “actively listen” can increase communications effectiveness significantly

Active listening involves:

- Establishing and maintaining eye contact.
- Focusing on what is being communicated.
- Not making judgments about the sender’s information.
- Not formulating your reply before the sender has finished sending his/her message.
- Paraphrasing key points the sender makes (when the sender pauses—don’t interrupt to paraphrase what’s being communicated).



Effective program management requires that the right people get the right information at the right time. Program communications must take place vertically (up and down), horizontally, and externally.

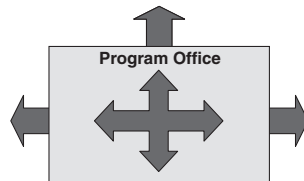

## Communications Plan

One way to ensure the right people get the right information at the right times is to develop a program (and/or team) communications plan. The plan may include:

- Key entities (program management leadership, IPTs, customer, contractor(s), and key stakeholders)
- What information they should provide
- What information they should receive
- How it is provided/received
- Format, frequency/interval, and other factors considered important for the particular program/situation
- Types of meetings, such as regular status meetings and program management reviews
- Reports (e.g., status reports, cost/schedule performance reports, action item lists)
- Issues and the policy for elevating them to higher levels
- Other forms of communication and how and by whom they are used



## Interpersonal Negotiation Techniques

**Purpose:** Resolving conflicts

**Objective:** Seek to satisfy both parties' interests

### Methodology:

- Acknowledge the conflict and its effect on performance.
- Separate people and emotions from the issue.
- Present issues in terms of the underlying interests or requirements, i.e., the most important aspects of what you need to achieve.
- LISTEN to the other party's interests/requirements; be able to restate their interests to their satisfaction (indicating you understand what interests they are trying to achieve).
- Agree on what the issue is.
- Look for common goals and common interests.
- Identify as many possible alternatives to resolve the issue and satisfy the interests of both parties.
- Resist the urge to compromise ("meet in the middle"). Instead, look at the issue from different perspectives—challenge assumptions and constraints.
- Agree on the alternative that best meets both parties' interests.
- Obtain the commitment of all members of both parties on what will be done to implement the solution.



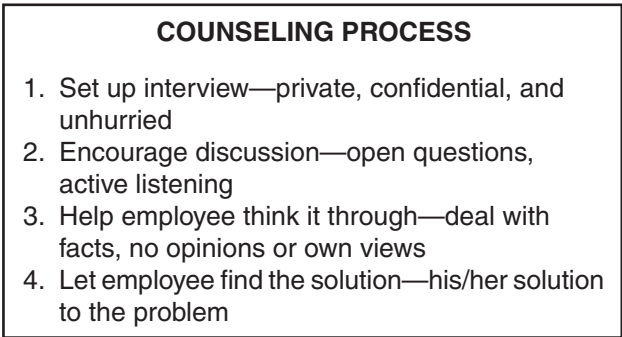
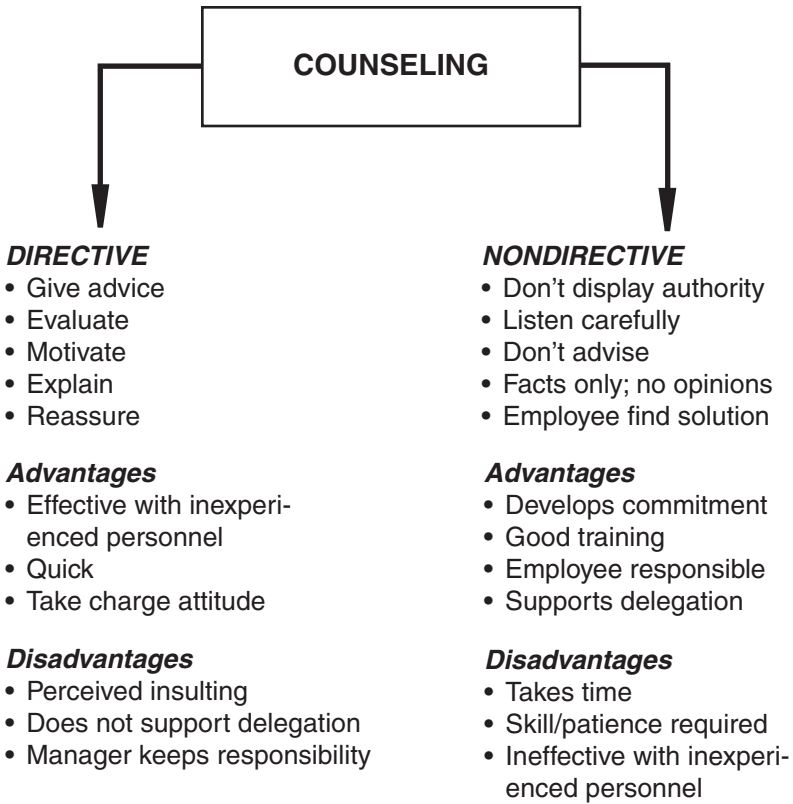

## TIME MANAGEMENT

1. List all the tasks you have to complete.
2. Prioritize the tasks based on urgency and importance of completion using the format shown below.
3. Do Priority 1 tasks first. If possible delegate some of them.
4. The key to effective time management is to schedule time to work on small pieces of Priority 2 tasks.  
— If not completed early, they will eventually become Priority 1 tasks.
5. Reassign or delegate Priority 3 tasks if possible.  
— A common tendency is focusing on Priority 3 tasks (because of their urgency) instead of Priority 2 tasks (because of their importance).
6. Priority 4 tasks are time wasters/busy work and should be avoided.



<b>Priority 1</b>	Important Urgent	<b>Priority 2</b>	Important Not Urgent
<b>Priority 3</b>	Urgent Not Important	<b>Priority 4</b>	Not Urgent Not Important

### Common Time Robbers

### Avoidance Techniques

- |   |   |
|---|---|
| <ul style="list-style-type: none"> <li>• Incoming telephone calls</li> </ul>  | <ul style="list-style-type: none"> <li>✓ Screen for importance</li> <li>✓ Allow voice mail to pick up the call</li> <li>✓ Limit length of calls (e.g., 2 min.)</li> </ul>                               |
| <hr style="border-top: 1px dashed black;"/>                                   |   |
| <ul style="list-style-type: none"> <li>• Outgoing telephone calls</li> </ul>  | <ul style="list-style-type: none"> <li>✓ Do as many at one time as possible</li> <li>✓ Itemize topics before calling</li> <li>✓ Stick to the topic; don't socialize</li> </ul>                          |
| <hr style="border-top: 1px dashed black;"/>                                   |   |
| <ul style="list-style-type: none"> <li>• Unscheduled visitors</li> </ul>      | <ul style="list-style-type: none"> <li>✓ Screen for importance</li> <li>✓ Do not invite visitor into your office</li> <li>✓ Remain standing</li> <li>✓ Schedule a time for visitor to return</li> </ul> |
| <hr style="border-top: 1px dashed black;"/>                                   |   |
| <ul style="list-style-type: none"> <li>• Improper delegation</li> </ul>       | <ul style="list-style-type: none"> <li>✓ Re-delegate</li> <li>✓ Make a record of delegated tasks</li> <li>✓ Assign deadlines</li> </ul>   |
| <hr style="border-top: 1px dashed black;"/>                                   |   |
| <ul style="list-style-type: none"> <li>• Poorly conducted meetings</li> </ul> | <ul style="list-style-type: none"> <li>✓ Have a prepublished agenda</li> <li>✓ Stay focused on subject</li> <li>✓ Use a time keeper/gate keeper</li> </ul>  |

## MANAGEMENT TOOLS AND TECHNIQUES

- 1. Activity-Based Management (ABM)** uses detailed economic analyses of important business activities to improve strategic and operational decisions. ABM increases the accuracy of cost information by more precisely linking overhead and other indirect costs to products or customer segments. Traditional accounting systems distribute indirect costs using bases such as direct labor hours, machine hours, or materiel dollars. ABM tracks overhead and other indirect costs by activity, which can then be traced to products or customers.
- 2. Balanced Scorecard** defines what management means by “performance” and measures whether management is achieving desired results. The Balanced Scorecard translates mission and vision statements into a comprehensive set of objectives and performance measures that can be quantified and appraised. These measures typically include: financial, customer value, internal business process, learning and growth, and employee performance.
- 3. Cycle Time Reduction** decreases the time it takes a company or program to perform key activities throughout its value chain. Cycle Time Reduction uses analytic techniques to minimize waiting time, eliminate activities that do not add value, increase parallel processes, and speed up decision processes within an organization. Time-based strategies often emphasize flexible manufacturing, rapid response, and innovation in order to attract the most profitable customers.
- 4. Groupware** refers to a broad range of technologies that allow people in organizations to work together through computer networks. These products range from sophisticated electronic mail packages to applications that link offices and employees. Organizations use such technology-aided communications to better inform strategic and financial decisions and to more effectively and economically bring together working groups. (DAU has a Groupware capability in its Management Decision Center, which is used for management decision making by offices and agencies throughout DoD.)

- 5. Outsourcing** occurs when a company or government agency uses third parties to perform non-core business activities. Contracting third parties enables a company or agency to focus its efforts on its core competencies. Many companies find that outsourcing reduces cost and improves performance of the activity. Third parties that specialize in an activity are likely to be lower cost and more effective, given their scale. Through outsourcing, a company or agency can access the state of the art in all of its business activities without having to master each one internally.
- 6. Business Process Reengineering** involves the fundamental redesign of core business processes to achieve significant improvements in productivity, cycle times, and quality. In Business Process Reengineering, companies start with a blank sheet of paper and rethink existing processes to deliver more value to the customer. They typically adopt a new value system that places increased emphasis on customer needs. Companies and/or government agencies reduce organizational layers and eliminate unproductive activities in two key areas: First, they redesign functional organizations into cross-functional teams. Second, they use technology to improve data dissemination and decision making.
- 7. Strategic Planning** is a comprehensive process for determining what a commercial business or government agency should become and how it can best achieve that goal. It appraises the full potential of a business and explicitly links the business objectives to the actions and resources required to achieve them. Strategic Planning offers a systematic process to ask and answer the most critical questions confronting a management team—especially large, irrevocable resource commitment questions.

## CONTINUOUS PROCESS IMPROVEMENT/ LEAN SIX SIGMA (CPI/LSS)

(DoD Directive 5010.42, 15 May 2008)

- “Lean” and “Six Sigma” are actually two distinct process improvement ideas often merged together forming “Lean Six Sigma.”
- “Sigma” is the term used for standard deviation—a statistical measure of variation. Variation can be decreased via Standard Operating Procedures (SOPs) and training.
- “Lean” references a process that can be shortened by eliminating non-value-added steps.
- Operating at a “Six Sigma” level of performance means the process theoretically produces a 99.99966% defect-free yield or 3.4 Defects Per Million Opportunities (DPMO).

<b>Lean</b>	<b>Six Sigma</b>
<ul style="list-style-type: none"> <li>• Reduces waste</li> <li>• Eliminates “non-value added” activities</li> </ul>	<ul style="list-style-type: none"> <li>• Eliminates variability</li> <li>• Strives to eliminate defects</li> <li>• Uses 5-Step Process*</li> </ul>

\* Five-Step Process: Define, Measure, Analyze, Improve, Control (DMAIC)

### Decide Which Opportunities Require Lean Six Sigma and Which Require Just Lean or Six Sigma

If ...	Then ...
<ul style="list-style-type: none"> <li>• Slow, wasteful business processes are the problem</li> <li>• Little or no historical process data</li> <li>• <b>GOAL: Process speed</b></li> </ul>	<ul style="list-style-type: none"> <li>• <b>Focus on Lean</b> <ul style="list-style-type: none"> <li>— Elimination of “non-value added” activities</li> <li>— Workflow simplification</li> </ul> </li> </ul>
<ul style="list-style-type: none"> <li>• Streamlined, highly efficient business processes</li> <li>• Process variability identified as a problem based on statistically significant historical data</li> <li>• <b>GOAL: Process consistency</b></li> </ul>	<ul style="list-style-type: none"> <li>• <b>Focus on Six Sigma</b> <ul style="list-style-type: none"> <li>— Elimination of variation factors and lack of control</li> <li>— Data-driven management</li> </ul> </li> </ul>
<ul style="list-style-type: none"> <li>• Slow, wasteful business processes combined with low performance or quality variability</li> <li>• <b>GOAL: Speed and consistency</b></li> </ul>	<ul style="list-style-type: none"> <li>• <b>Focus on integrated Lean and Six Sigma</b> <ul style="list-style-type: none"> <li>— Methodology as a total performance solution</li> <li>— Total process view with embedded measurement and assessment capabilities leading to positive performance management</li> </ul> </li> </ul>

## CHAPTER 3

# PROBLEM-SOLVING TOOLS

### BRAINSTORMING

**PURPOSE:** To stimulate the free flow of ideas in a short amount of time without being analyzed or judged until the brainstorming is complete.

**METHOD:** There are three primary types of brainstorming: structured, unstructured, and silent.

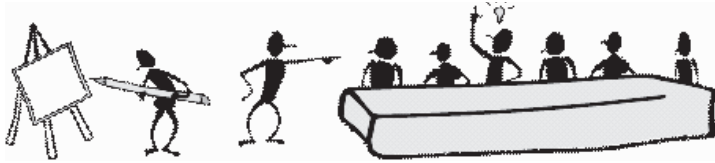

- **Structured:** Participants take turns offering ideas; if someone doesn't have an idea when their turn comes, they can pass.
  - Advantage: Each person has an equal chance to participate.
  - Disadvantages: Lacks spontaneity; participants may get distracted by other ideas and forget theirs when their turn comes, atmosphere is more rigid.
  
- **Unstructured:** Participants offer ideas as they think of them.
  - Advantage: Participants can build on each others' ideas; atmosphere is more relaxed.
  - Disadvantage: Less assertive and/or lower ranking participants may feel intimidated and not contribute.
  
- **Silent:** Participants write ideas individually on paper or Post-it™ notes. This is particularly useful when you have participants who just can't avoid discussing the ideas as they are offered.
  - Advantage: Prevents discussion of ideas during the idea generation phase.
  - Disadvantages: May lose the opportunity to build on others' ideas unless a structured or unstructured session is held after the silent inputs are collected and displayed.

The brainstorming session ends when no more ideas are offered.

## GROUND RULES:

***Don't discuss ideas as they are offered.*** In particular, don't analyze, evaluate, criticize, or judge. Discussion can be held after the brainstorming session ends.

***There are no outrageous ideas.*** There is plenty of time during the discussion after the brainstorming session to toss out ideas that won't work. Even if idea is totally outrageous and obviously won't work, it may spark another idea that is usable.

***Don't quit when the ideas first stop flowing;*** try to get participants to come up with at least 2-3 more ideas.

***Strive for quantity, not quality.*** The more ideas you generate, the better the opportunity to find the best possible solution.

***Combine and rearrange ideas;*** additions, revisions, and combinations may create even better ideas.

***Record ideas exactly as offered,*** don't edit or paraphrase.

## QUESTIONS TO STIMULATE YOUR THINKING:

1. Can we use this idea somewhere else? As is? With changes?
2. If we change it, is there anything else like it? Any related issues?
3. Can we modify or rearrange: the meaning, quantity, color, size, shape, form, layout, motion, sound, appearance, etc.?
4. Can we maximize or magnify it to make it stronger, larger, newer, more of it?
5. Can we minimize or reduce it to make it smaller, lighter, less of it?
6. Can we substitute? Who? What? When? Where? How?
7. Can we reverse it? Opposite? Backwards? Upside down? Inside out?
8. What assumptions or constraints are we considering? Are they valid? What if we threw them out?
9. What if you could do anything you can imagine?

## CAUSE-AND-EFFECT DIAGRAM ("FISHBONE" OR ISHIKAWA DIAGRAM)

**PURPOSE:** To help analyze a problem in increasing detail to identify all of its causes, leading to discovery of its root cause(s). The Cause-and-Effect Diagram graphically depicts the relationship between a problem and its causes.

**METHOD:**

- Use brainstorming to generate the potential or known causes for the problem (or effect) being studied.
- Begin constructing the "fishbone" diagram by placing the problem statement on the right side of the chart (head of the "fishbone").
- Draw an arrow from left to right ending at the problem statement (the backbone of the "fishbone").
- Place the major cause categories (If known) as the major "bones" of the fishbone, as shown in the example below (in the example: people, product, process, equipment).
- If the major causes are not known, after brainstorming all the causes, sort them into similar groups using the Affinity Diagram. The titles of the groups become the major cause categories.
- Add the brainstormed causes as the smaller bones in the diagram as shown in the example below (e.g., inadequate training, poor teamwork, etc.). Causes can be added to the major categories after all the causes have been generated via brainstorming (recommended), or added as they are generated.
- To spark additional brainstorming of causes, ask for each of the "small bone" causes: "What causes this to happen?"

**EXAMPLE:**

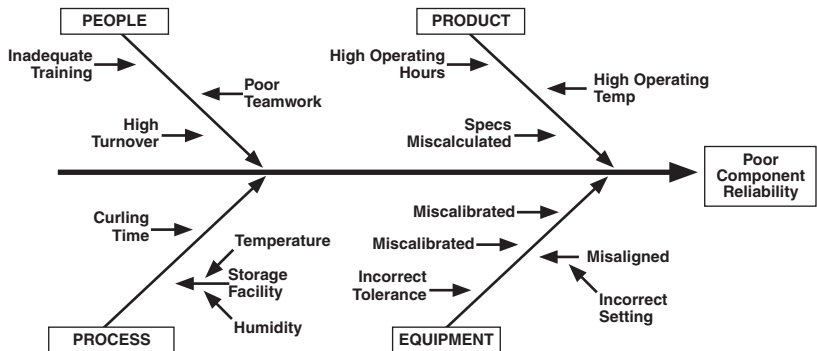

## FORCE FIELD ANALYSIS

**PURPOSE:** To identify the factors or forces that either support or work against a desired outcome.

**METHOD:**

- Draw a “T” shape as shown below.
- Brainstorm the forces that will assist you in achieving the desired outcome. List them on the left side of the vertical line.
- Brainstorm the forces that may prevent or restrain you from reaching your outcome. List them on the right side of the line.
- (Optional) Prioritize the driving forces (left side) and/or the restraining forces (right side).
- Look for opportunities to take advantage of or strengthen driving forces.
- Identify restraining forces that you might be able to eliminate (or reduce the “force” or impact).
- It is often more helpful to eliminate restraining forces than attempting to strengthen driving forces. In most cases, the driving forces will remain present and continue to help you even if you do nothing to strengthen them; whereas eliminating restraining forces can have significant benefits in achieving your objective/outcome.
- In a “pound-for-pound” or “best bang for the buck” fashion, the force field analysis is one of the most powerful tools in terms of the effort required to generate it and the potential benefits derived from it.
- Restraining forces can also be identified as potential risks, and entered into the risk management tracking system.

**EXAMPLE:**

**OBJECTIVE: Successfully Complete Preliminary Design**

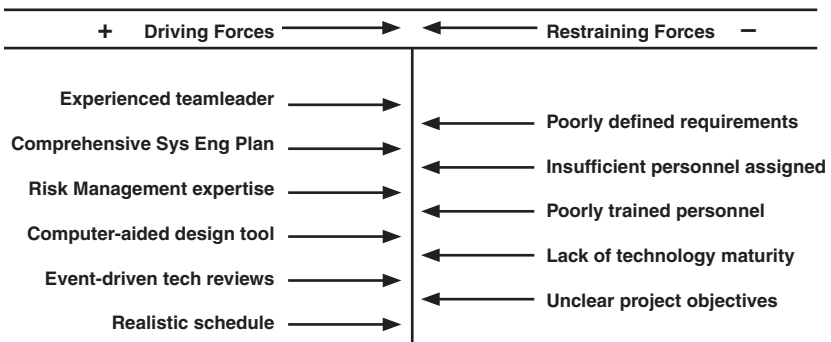

## HISTOGRAM

**PURPOSE:** To graphically depict the frequency distribution of data items using a vertical bar chart (columns) format.

### METHOD:

- Collect data on a particular variable.
- Generate a frequency table listing all the data points.
- Count the number of data points.
- Determine the range of values for the data (maximum value minus the minimum value).
- Determine the number of bars to depict in the chart. One common method is to use the square root of the number of data points; e.g., 100 data points = 10 bars; 225 data points = 15 bars, etc.
- Calculate the intervals represented by each of the bars. The simplest method is to divide the range of values by the number of bars (from previous step).
- Determine the frequency of data points within each interval of values.
- Create a vertical bar chart with a vertical bar (column) for each of the variable values or range of values you measured on the horizontal axis. The height of the bar will equal the frequency (on the vertical axis) for each of the values/ranges.

### EXAMPLE:

- In the example below, the sample size is 220 data points (N=220).
- The square root of 220 is between 14 and 15, so either will work for the number of bars in the chart (14 bars are used in the example).
- The range of values is 350 hrs (1350 hrs minus 1000 hrs). Dividing the range (350) by the number of bars (14) results in intervals of 25 hrs.

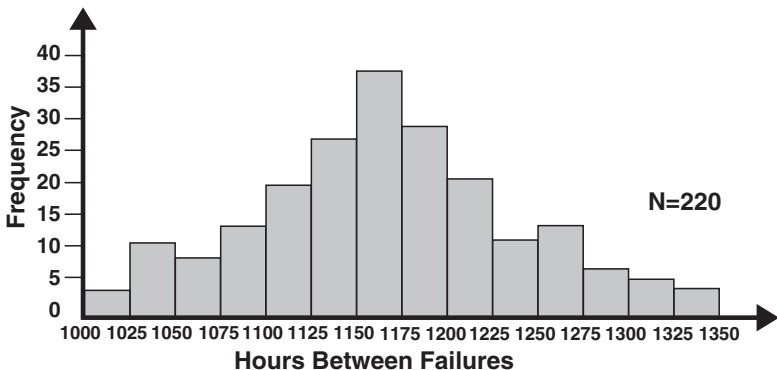

## SCATTER DIAGRAM

**PURPOSE:** To graphically depict the changes in two variables to determine if there is a relationship between them.

**METHOD:**

- Collect paired data samples for the two variables.
- Place measures for the independent variable (the hypothesized cause) on the horizontal axis, and measures for the dependent variable (the hypothesized effect) on the vertical axis.
- Plot the data on the chart
- Analyze the data to determine if there is a statistical relationship between the two variables.

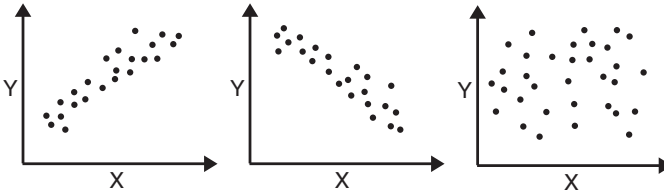

**Positive Correlation**

For an increase in "X" there is a corresponding increase in "Y"

**Negative Correlation**

For an increase in "X" there is a corresponding decrease in "Y"

**No Correlation**

For an increase in "X" there is no corresponding reaction in "Y"

**EXAMPLE:**

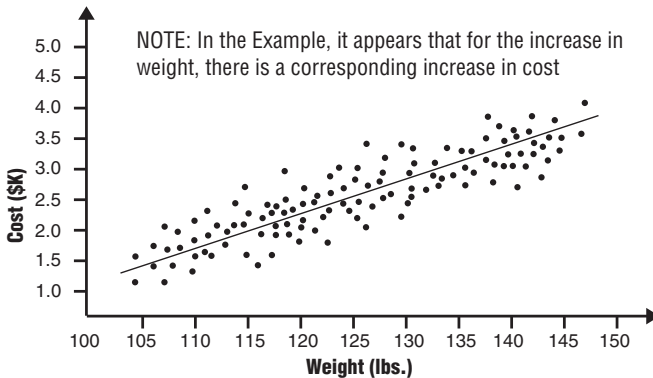

## SURVEYS

Surveys are used to collect data from a variable number of items or people for a comparative study. They are used when a new project is planned to prove the need and the demand of the customer.

Surveys can be used anywhere in the organization to find out specific information that is necessary to make improvements in a process.

### Surveys:

- Are an inexpensive way to test a system or product;
- Can be used with a large number of people or a small group;
- Can give you an overall view, determined by the questions you ask;
- Show if an organization is meeting its quality goals; and
- Help identify satisfied and dissatisfied customers or employees.

### Survey Process

1. Determine the group to be studied.
2. Determine what questions will be asked.



**BRAINSTORMING**



**SURVEY**

**Note:** Train your data collectors thoroughly. Everyone must know how to ask the questions, whom to approach, and how to approach them.

3. Compile your results in chart form using a Pareto Chart (see page 130), histogram, and other tools that will give you clarification.
4. Use the compounded data to form a base for improvement.
5. Continue to take data to monitor improvements and make sure the improvements you have made are working.

### Caution!

- Data must be collected honestly and consistently.
- An untrained collector can skew the data to reflect personal biases.
- A poor, inconsistent survey will give you invalid data.
- Make sure there is enough time allowed for the collecting process.

## AFFINITY DIAGRAM

**PURPOSE:** To help a team generate a large number of ideas or issues and organize them into categories for further analysis, evaluation, decision, or action.

**METHOD:**

- Agree on what the problem, issue, question, or desired outcome is.
- Brainstorm as many ideas about the problem, issue, question, or desired outcome as you can.
- Without discussion, sort the ideas into related groups.
- If two people can't agree on which category it best fits, consider duplicating it and including it under both.
- For each group, identify a name that summarizes the topics listed for them.

Tip: Use Post-it™ type notes to record the ideas on, which allows you to easily move the ideas from one category to another.

**EXAMPLE:**

### What are the Attributes of an Effective Leader?

<p><b>Integrity</b></p> <p>Honesty Trustworthy Does the right things Loyal Courageous Sets the example</p>	<p><b>Coaching/Mentoring</b></p> <p>Provides career counseling Supports training Provides professional growth opportunities</p>	<p><b>Motivation</b></p> <p>Inspires Focused on people Trusting Caring Sets high standards Empowers Supportive</p>
<p><b>Change Agent</b></p> <p>Drives change Innovative</p>	<p><b>Visionary</b></p> <p>Has a big picture view Clearly stated goals</p>	<p><b>Communication</b></p> <p>Good listener Effective speaker Encourages open communication</p>
<p><b>Knowledgeable</b></p> <p>Strong technical expertise</p>	<p><b>Decisive</b></p> <p>Makes decisions Involves others in decisions</p>	

**Note:** Attributes shown above are for illustration only, and not meant to portray actual answers to the question.

## PAIRWISE RANKING

**PURPOSE:** To provide a structured method for ranking small lists of items in priority order.

**METHOD:**

- Construct a pairwise matrix.
  - Each of the squares in the matrix at right represents the pairing of two items (where the numbers intersect).
  - In this example, the list includes five items; the top square (shaded) represents the pairing of item 1 with item 2.
- Rank each pair of items.
  - For each pair of items, the team should reach a consensus on which of the two items is preferred over the other.
  - As the team completes each of the comparisons, the number of the preferred item is recorded in that square, until the matrix is completely filled in.

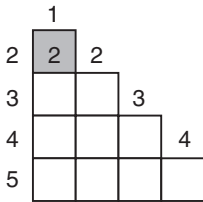
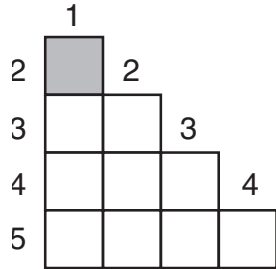

1 and 2 are compared;  
2 is preferred

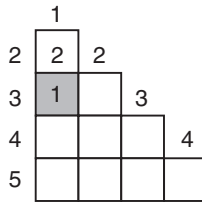

1 and 3 are compared;  
1 is preferred

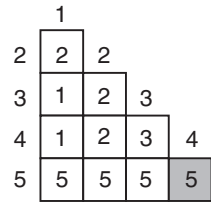

...and finally, 4 and 5 are compared; 5 is preferred

- Count the number of times each item appears in the matrix.
  - Using the filled-in matrix (on the far right above), count how many times each item is listed in the matrix, and record the totals in the ranking matrix (at right).

<b>Alternative</b>	1	2	3	4	5
<b>Count</b>	2	3	1	0	4
<b>Rank</b>					

DAU PROGRAM MANAGERS TOOL KIT

- Rank all of the items.
  - Rank the items based on how many times they appear in the matrix.
  - To break a tie between two items appearing the same number of times, look at the square in the matrix where the two were compared; the item appearing in that box receives the higher ranking.

Items 5 appear four times in the matrix, so it ranks 1st (see shaded squares in the matrix at right); Item 2 appears three times, which ranks 2nd, etc.

<b>Alternative</b>	1	2	3	4	5
<b>Count</b>	2	3	1	0	4
<b>Rank</b>	3rd	2nd	4th	5th	1st

**EXAMPLE:**

A program team was asked to recommend a site for testing a unique portion of a system. A feasibility study produced a list of six possible locations. The team then used Pairwise Ranking to determine that Nellis AFB was best suited for this particular test.

- |                  |                |
|------------------|----------------|
| 1. Fort Huachuca | 4. Nellis AFB  |
| 2. Edwards AFB   | 5. Eglin AFB   |
| 3. Kirtland AFB  | 6. Hanscom AFB |

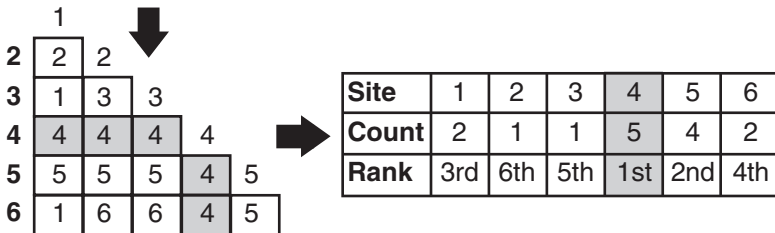

## PARETO CHART

**PURPOSE:** To help identify and prioritize issues or problems, identify root causes, or evaluate results of improvement areas. The Pareto Chart graphically displays the frequency of occurrence of data items.

**METHOD:**

- Decide on the categories of items (e.g., issues or causes) on which to focus.
- Choose the measurement units which provide the most meaningful comparison between the categories of items.
- Determine the time period to collect data.
- Collect data on the chosen categories of items.
- Create a frequency table listing all the categories, the frequency of their occurrence, and the percentage of their occurrence.
- Create a vertical bar chart with a vertical bar (column) for each of the categories you measured on the horizontal axis, starting with the category with the highest frequency of occurrence on the far left side and continuing in descending order to the right to the category with the lowest frequency of occurrence on the far right side. The height of the bar will equal the frequency (on the left vertical axis) for each of the categories.
- (Optional) Draw a line showing the cumulative percentage of the categories from left to right (0-100%). Draw a vertical axis on the right side showing the percentage scale.

**EXAMPLE:**

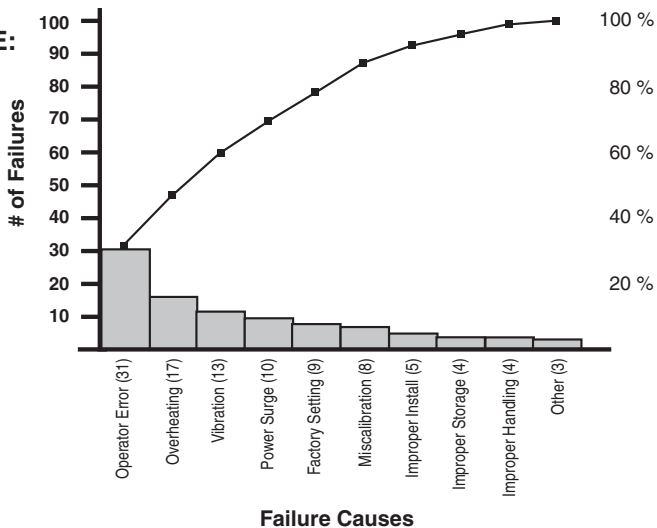

## BENCHMARKING

Benchmarking is the process of measuring products, services, and practices against the toughest competitors or those known as leaders in their field. Benchmarking can help you:

- Understand how you compare with similar organizations; and
- Identify areas for process improvement.

### HOW TO DO IT:

**Identify the process to be benchmarked.** Select a *process* (as opposed to a product) that is important to both your organization and your customers. Be sure the process in your organization is similar to *and measured in the same manner as* the one to which it's being compared.

**Study other organizations.** Develop a list of organizations with comparable products and services. Determine what specific processes the organization performs. Based on this information, rank the organizations from best to worst.

**Compare and evaluate.** Compare your *process* to the best and worst cases and list the important differences. These differences can suggest potential improvements to your process.

### BENCHMARKING EXAMPLE:

Using inputs their customers provided, the executive leaders at AF Product Division B decided that their source selection process needed improvement. As part of the initial analysis, they wanted to see how their process compared with others. They determined that the average number of days required for source selection was an important process measure.

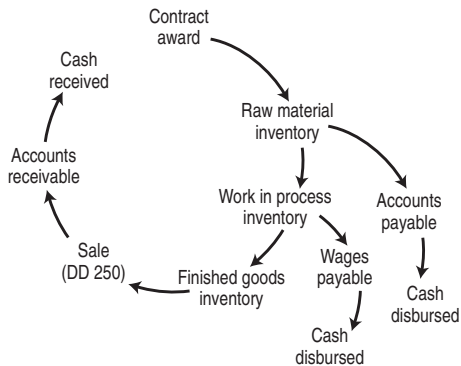

As a result of this analysis, representatives visited AF Product Division A and Navy Division B and studied their source selection procedures.

**Note:** Benchmarking is *not* replicating a process from an organization that excels (unless your goal is to be 2nd best). It *is* studying the process, clearly understanding the theory behind the process, and then restudying your own process to determine improvements.

## FLOWCHARTING





**PURPOSE:** To identify the steps or tasks in a process. The current process can then be analyzed to discover duplicate or unnecessary actions, bottlenecks, or other problem areas. Ideas for improvement can then be identified.

**METHOD:**

- Clearly define where the process begins and ends.
- List all of the steps in the process, including decision points, and inputs to and outputs from the process.
- Arrange the steps of the process in the sequence in which they currently occur. If it is a new process, begin with the sequence in which you believe they will occur.
- Draw the appropriate symbols for each of the items in the process.
- Label the items in the process with text describing that item.
- Add arrows showing the process flow.
- Review for accuracy.
  - Correct symbols
  - Correct labels
  - Correct sequence
  - Correct direction of flow

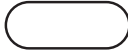
**EXAMPLE:**

**Common Flowchart Symbols**

	<b>Terminator</b> - shows the beginning and ending points of the process. Start points are usually some sort of trigger activity for the process.
	<b>Activity</b> - an action step or process (within the process).
	<b>Decision Point</b> - where a decision is required; usually with two options (e.g., yes/no).
	<b>Document</b> - a step or action that produces a document.
	<b>Connector</b> - shows a jump from one point in the process to another, or to another page. Usually labeled with letters (e.g., A<B<C< etc.).

**EXAMPLE:**

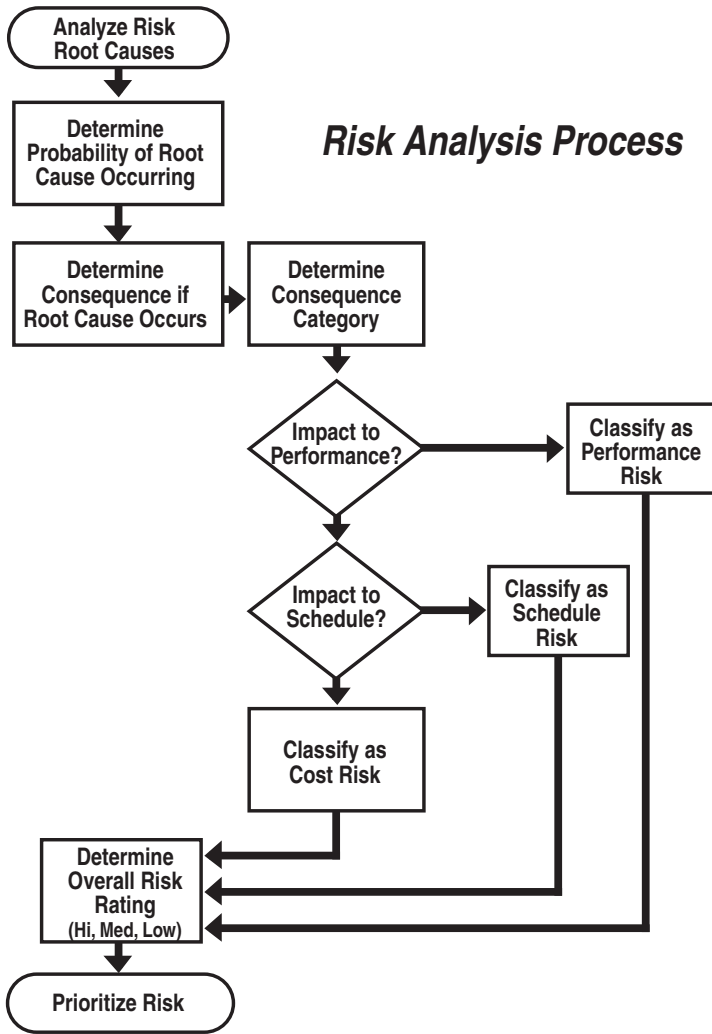

## DEPLOYMENT FLOWCHARTS

**PURPOSE:** Depicts a process and the individuals or teams responsible for the steps/actions in the process. The Deployment Flowchart can be useful to clarify individual or team roles and responsibilities, and also to detect/prevent duplication of effort.

**METHOD:**

- List the steps of the current process.
- Identify the individuals/teams involved.
- Draw the Deployment Flowchart showing the activities, decisions, inputs, outputs, documents, etc. (see example below).
- List the individuals/teams across the top of the chart, and the timeline (if applicable) down the side (see example below).
- Evaluate the current process for possible changes, and update as necessary.

**EXAMPLE:**

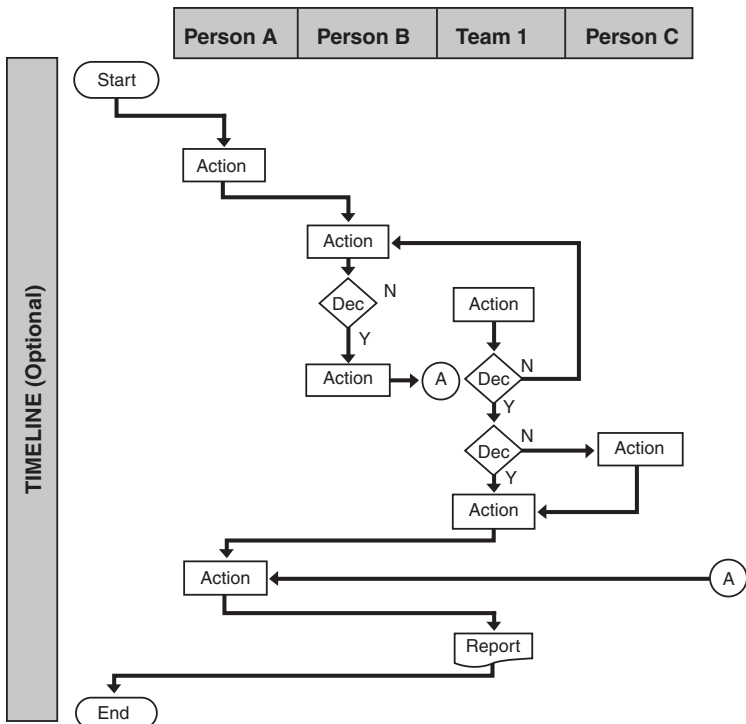

## NOMINAL GROUP TECHNIQUE (NGT)

**PURPOSE:** To rank or prioritize the importance of issues, alternatives, or processes. Helps a team reach consensus quicker by showing preliminary areas of agreement. Allows individual team members to assign a rank or priority to items without influence or pressure from others.

### METHOD:

- Brainstorm a list of the issues, alternatives, or processes that you are analyzing.
- Compile a final list of brainstorming inputs by eliminating duplicate or similar inputs, and clarifying the meanings of any inputs that are unclear.
- Each team member votes by ranking the inputs in order of importance (see first example on next page).
- The highest number is generally used to indicate the most important or highest priority item. For example, if team members are ranking 10 items, “10” would represent the most important item and “1” the least important item. Make sure you specify the values used in the ranking, i.e., which number represents the highest or most important rating, and which represents the lowest, to ensure there is no confusion.
- Team members may rank all of the items, or some pre-designated portion of the items (particularly when there is a long list), such as a third or a half.
- Add all of the rankings, and analyze the results.
- Unless the team is pressed for time, use the ranking information as a starting point for discussion instead of accepting it as a “final score.”
- An alternate method is to assign each team member a number of points (e.g., 100), which they allocate across the options (some or all). This variation is known as weighted multivoting (see second example on next page).
- When using weighted multivoting, it’s a good idea to assign a maximum number of points that can be assigned to any one item (e.g., 40 out of 100) to prevent one team member from over-representing the relative importance of an item (see Item H in the second example on the next page).



**Problems with Team Performance (Ranking for Example)**

<b>Causes (7)</b>	<b>Peter</b>	<b>Paul</b>	<b>Mary</b>	<b>Total</b>
<b>Inadequate team training</b>	6	3	5	14
<b>Unclear objectives</b>	4	7	3	14
<b>Insufficient resource</b>	3	5	2	10
<b>High team member turnover</b>	2	2	4	8
<b>Inefficient team process</b>	5	6	7	18
<b>Team member hidden agendas</b>	7	4	6	17
<b>Poor functional representaion</b>	1	1	1	3

**Weighted Multivoting Example**

<b>Issues (12)</b>	<b>John</b>	<b>Paul</b>	<b>Ringo</b>	<b>George</b>	<b>Total</b>
<b>Item A</b>	40	30	10	20	100
<b>Item B</b>		5			5
<b>Item C</b>	10	10		20	40
<b>Item D</b>	10			20	30
<b>Item E</b>		20		10	30
<b>Item F</b>	5		5		10
<b>Item G</b>	15	20	20	20	75
<b>Item H</b>			50		50
<b>Item I</b>	10	5		5	20
<b>Item J</b>		5	10		15
<b>Item K</b>	10				10
<b>Item L</b>		5	5	5	15

## CREATIVE PROBLEM SOLVING

- Diverge** ↙ 1. Identify the goal or challenge.
- Converge** ↘ 2. Gather relevant data.
- ↙ 3. Define the problem.
- ↘ 4. Generate potential solutions.
- ↙ 5. Select, and if possible, strengthen the solution.
- ↘ 6. Develop a plan to implement the chosen solution.

Each six steps above has a *Divergent* Phase (↙) followed by a *Convergent* Phase (↘). See below for a description of the steps in each phase

### **DIVERGENT PHASE**

1. Avoid judging or evaluating ideas as they are offered
2. Generate as many ideas as possible
3. Accept all the ideas generated
4. Stretch your thinking
5. Allow time for ideas to “grow”
6. Combine or connect ideas or concepts



### **CONVERGENT PHASE**

1. Use a logical, methodical approach to make choices or decisions
2. Clearly and specifically state the basis for evaluating ideas
3. Avoid a rush to closure
4. Don't ignore or avoid difficult issues
5. Look for strengths or positive aspects of ideas
6. Remain focused on the objectives



## RESPONSIBILITY ASSIGNMENT MATRIX (RAM)

**PURPOSE:** Display actions, tasks, or assignments; and what responsibilities each individual has for them.

**METHOD:**

- Brainstorm a list of actions or tasks the team must complete.
- List the team members and other stakeholders who may have responsibilities.
- Construct a matrix with the actions/tasks listed down the left side of the matrix, and the people listed across the top.
- Choose the symbols to indicate the level of responsibility represented in the matrix (e.g., primary, secondary, keep informed, etc.).
- Agree on the individual responsibilities and complete the matrix by placing the symbols for each step/task under the appropriate people.
- Generally, only one person should have primary responsibility, others with some responsibility would have secondary responsibility.

**EXAMPLE:**

**Goal:**

Establish and maintain an effective risk management program

Tasks	PM	Risk Coord	RM IPT	RMIS Mgr	Prog IPTs	Risk SMEs
Communicate Risk Mgmt Goals	⊙					
Identify Risk Coordinator	⊙					
Establish Risk Mgmt IPT (RM IPT)	⊙					
Draft Risk Mgmt Plan		⊙	I			
Approve Risk Mgmt Plan	⊙	R				
Identify Risk Events		⊙	C		I	I
Analyze Risks		⊙	C		I	I
Prioritize Risks		⊙	C		I	I
ID/Evaluate Mitigation Strategies		⊙	R		I	I
Select Risk Mitigation Strategies	⊙	R	C			
Enter Risk in Risk M13 (RM13)		○		⊙		

**Legend:**

⊙ = Primary Respond

○ = Second Respond

R = Review

C = Coord

I = Input

## KNOT CHART

**The KNOT Chart is useful for:**

- Initially sorting the wheat from the chaff.
- Organizing/coordinating the next steps of the problem-solving process.

<b>Know</b>	<b>Need to Know</b>	<b>Opinion</b>	<b>Think We Know</b>

As you work your way through the problem, everything should move into the left column—"Know."

## QUALITATIVE PROBLEM SOLVING

Deviation Statement: Describe the actual performance vs. should performance

	Is	Is Not	What is distinctive about "Is" vs. "Is Not"?	Does the distinction suggest a change?
<b>Specifying Question</b>  <b>What? (Identify)</b>  <b>Where? (Location)</b>  <b>When? (Timing)</b>  <b>Extent? (Magnitude)</b>				
<b>Possible Causes:</b>				
<b>Most Likely Cause:</b>				

1. Define deviation.
2. Describe what deviation IS and IS NOT.
3. List distinctions between what deviation IS and IS NOT.
4. Do distinctions indicate or suggest a change?
5. Determine possible causes based on distinctions and changes.

Copyright Kepner Tregoe, Inc. (1981). All rights reserved. Reprinted with permission. (Kepner-Tregoe, Inc., Research Road, P.O. Box 704, Princeton, N.J. 08542)

## GANTT CHART

A Gantt Chart is used for planning schedules and managing projects. It is a method for basic planning and work instruction.

### How to do it:

1. The Gantt Process begins by listing the activities of a project in order of execution.

<b>ACTIVITIES</b>
1. Requirements are written
2. Finances are arranged
3. Bidding takes place
4. Contractor is selected
5. Prototype is built
6. Testing begins

2. Place the number of each activity across the top of your chart. Time duration such as days, weeks, years, etc., can replace activity numbers if appropriate.
3. Draw vertical lines across the chart for each item.
4. Starting with number 1, begin comparing the activities. Can number 1 be done at the same time as number 5 or 6?
5. Draw horizontal lines to indicate which activities can be done simultaneously.

<b>ACTIVITIES</b>	<b>1</b>	<b>2</b>	<b>3</b>	<b>4</b>	<b>5</b>	<b>6</b>
1. Requirements are written						
2. Finances are arranged						
3. Bidding takes place						
4. Contractor is selected						
5. Prototype is built						
6. Testing begins						

6. You now have an overview of your project giving you a starting point and time-saving measures to help you complete the project on time.