

REPORT DOCUMENTATION PAGE			Form Approved OMB NO. 0704-0188	
<p>The public reporting burden for this collection of information is estimated to average 1 hour per response, including the time for reviewing instructions, searching existing data sources, gathering and maintaining the data needed, and completing and reviewing the collection of information. Send comments regarding this burden estimate or any other aspect of this collection of information, including suggestions for reducing this burden, to Washington Headquarters Services, Directorate for Information Operations and Reports, 1215 Jefferson Davis Highway, Suite 1204, Arlington VA, 22202-4302. Respondents should be aware that notwithstanding any other provision of law, no person shall be subject to any penalty for failing to comply with a collection of information if it does not display a currently valid OMB control number.</p> <p>PLEASE DO NOT RETURN YOUR FORM TO THE ABOVE ADDRESS.</p>				
1. REPORT DATE (DD-MM-YYYY)		2. REPORT TYPE		3. DATES COVERED (From - To)
		New Reprint		-
4. TITLE AND SUBTITLE			5a. CONTRACT NUMBER	
Jamming in mobile networks: A game-theoretic approach.			W911NF-09-1-0383	
			5b. GRANT NUMBER	
			5c. PROGRAM ELEMENT NUMBER	
			611103	
6. AUTHORS			5d. PROJECT NUMBER	
Sourabh Bhattacharya, Abhishek Gupta, Tamer Bas,ar				
			5e. TASK NUMBER	
			5f. WORK UNIT NUMBER	
7. PERFORMING ORGANIZATION NAMES AND ADDRESSES			8. PERFORMING ORGANIZATION REPORT NUMBER	
William Marsh Rice University Office of Sponsored Research 6100 Main St., MS-16 Houston, TX 77005 -1827				
9. SPONSORING/MONITORING AGENCY NAME(S) AND ADDRESS(ES)			10. SPONSOR/MONITOR'S ACRONYM(S) ARO	
U.S. Army Research Office P.O. Box 12211 Research Triangle Park, NC 27709-2211			11. SPONSOR/MONITOR'S REPORT NUMBER(S)	
			56177-CS-MUR.176	
12. DISTRIBUTION AVAILABILITY STATEMENT				
Approved for public release; distribution is unlimited.				
13. SUPPLEMENTARY NOTES				
The views, opinions and/or findings contained in this report are those of the author(s) and should not be construed as an official Department of the Army position, policy or decision, unless so designated by other documentation.				
14. ABSTRACT				
In this paper, we address the problem of jamming in a communication network within a team of mobile autonomous agents. In contradistinction with the contemporary research regarding jamming, we model the intrusion as a pursuit-evasion game between a mobile jammer and a team of agents. First, we consider a differential game-theoretic approach to compute opti-				
15. SUBJECT TERMS				
Jamming, pursuit-evasion, multi-player games, Nash Equilibrium,UAVs.				
16. SECURITY CLASSIFICATION OF:			17. LIMITATION OF ABSTRACT	15. NUMBER OF PAGES
a. REPORT	b. ABSTRACT	c. THIS PAGE	UU	19a. NAME OF RESPONSIBLE PERSON
UU	UU	UU		Richard Baraniuk
				19b. TELEPHONE NUMBER
				713-348-5132

## Report Title

Jamming in mobile networks: A game-theoretic approach.

### ABSTRACT

In this paper, we address the problem of jamming in a communication network within a team of mobile autonomous agents. In contradistinction with the contemporary research regarding jamming, we model the intrusion as a pursuit-evasion game between a mobile jammer and a team of agents. First, we consider a differential game-theoretic approach to compute optimal strategies for a team of UAVs trying to evade a jamming attack initiated by an aerial jammer in their vicinity. We formulate the problem as a zero-sum pursuit-evasion game, where the cost function is the termination time of the game. We use Isaacs' approach to obtain necessary conditions to arrive at the equations governing the saddle-point strategies of the players. We illustrate the results through simulations. Next, we analyze the problem of jamming from the perspective of maintaining connectivity in a network of mobile agents in the presence of an adversary. This is a variation of the standard connectivity maintenance problem in which the main issue is to deal with the limitations in communications and sensing model of each agent. In our work, the limitations in communication are due to the presence of a jammer in the vicinity of the mobile agents. We compute evasion strategies for the team of vehicles based on the connectivity of the resultant state-dependent graph. We present some simulations to validate the proposed control scheme. Finally, we address the problem of jamming for the scenario in which each agent computes its control strategy based on limited information available about its neighbors in the network. Under this decentralized information structure, we propose two approximation schemes for the agents and study the performance of the entire team for each scheme.

---

**REPORT DOCUMENTATION PAGE (SF298)**  
**(Continuation Sheet)**

---

Continuation for Block 13

ARO Report Number 56177.176-CS-MUR  
Jamming in mobile networks: A game-theoretic a ...

Block 13: Supplementary Note

© 2013 . Published in J. Numerical Algebra, Control and Optimization, 3(1):1-30, Vol. Ed. 0 (2013), (Ed. ). DoD Components reserve a royalty-free, nonexclusive and irrevocable right to reproduce, publish, or otherwise use the work for Federal purposes, and to authorize others to do so (DODGARS §32.36). The views, opinions and/or findings contained in this report are those of the author(s) and should not be construed as an official Department of the Army position, policy or decision, unless so designated by other documentation.

Approved for public release; distribution is unlimited.

## JAMMING IN MOBILE NETWORKS: A GAME-THEORETIC APPROACH

SOURABH BHATTACHARYA

Department of Mechanical Engineering  
Iowa State University, IA, 50011 Ames, USA

ABHISHEK GUPTA

Department of Aerospace Engineering  
University of Illinois at Urbana Champaign  
IL 61801, Urbana, USA

TAMER BAŞAR

Department of Electrical and Computer Engineering  
and Coordinated Science Lab  
University of Illinois at Urbana Champaign  
IL 61801, Urbana, USA

**ABSTRACT.** In this paper, we address the problem of jamming in a communication network within a team of mobile autonomous agents. In contradistinction with the contemporary research regarding jamming, we model the intrusion as a pursuit-evasion game between a mobile jammer and a team of agents.

First, we consider a differential game-theoretic approach to compute optimal strategies for a team of UAVs trying to evade a jamming attack initiated by an aerial jammer in their vicinity. We formulate the problem as a zero-sum pursuit-evasion game, where the cost function is the termination time of the game. We use *Isaacs'* approach to obtain necessary conditions to arrive at the equations governing the saddle-point strategies of the players. We illustrate the results through simulations. Next, we analyze the problem of jamming from the perspective of maintaining connectivity in a network of mobile agents in the presence of an adversary. This is a variation of the standard connectivity maintenance problem in which the main issue is to deal with the limitations in communications and sensing model of each agent. In our work, the limitations in communication are due to the presence of a jammer in the vicinity of the mobile agents. We compute evasion strategies for the team of vehicles based on the connectivity of the resultant *state-dependent graph*. We present some simulations to validate the proposed control scheme. Finally, we address the problem of jamming for the scenario in which each agent computes its control strategy based on limited information available about its neighbors in the network. Under this decentralized information structure, we propose two approximation schemes for the agents and study the performance of the entire team for each scheme.

---

2000 *Mathematics Subject Classification.* Primary: 49N75, 49N90.

*Key words and phrases.* Jamming, pursuit-evasion, multi-player games, Nash Equilibrium, UAVs.

This research was supported in part by the U.S. Air Force Office of Scientific Research (AFOSR) under grants FA9550-09-1-0249 and MURI FA9550-10-1-0573.

## 1. Introduction.

*An object in possession seldom retains the same charm that it had in pursuit.*

-Gaius Plinius Secundus

Situations involving pursuit and evasion frequently arise in combat scenarios. Game theory, especially differential games, is an important tool in analyzing such situations of conflict. One of the earliest works that illustrates the connection between differential games and pursuit-evasion is the seminal work of Isaacs that culminated in his book [27]. A general framework based on the concepts in classical game theory and the notion of *tenet of transition* was used to analyze pursuit-evasion problems. Classical problems like the *Lion and the Man*, *Homicidal Chauffeur* and *Maritime Dogfight* were introduced in this book. In addition to the formulation of these problems that relate to real-life scenarios, Isaacs' book also provides the necessary conditions for optimal trajectories for the players. In 1967, within two years after the publication of Rufus Isaacs' book on differential games, Leitmann developed an analysis similar to that of Isaacs in [15], by building on his own geometric approach to control theory [34]. He based his geometric viewpoints on the properties of certain surfaces which contain the optimal trajectories: the limiting surfaces in control theory and the game surfaces in differential games. An elaborate history of the various generalizations and modifications of the classical problems in pursuit-evasion and the formulation of new problems, is presented in [5] and [40]. In the past, most of the problems in pursuit-evasion games, for example [33], [35], [38] and [37] have tried to relate the performance of the players to their agility and on-board energy. In this paper, we investigate a novel pursuit-evasion game that relates the agility of the agents in a team to their capability to maintain a secure communication network in the presence of an adversary.

The problem under consideration in this paper is inspired by recent discoveries of jamming instances in biological species [63]. Jamming is a malicious attack whose objective is to disrupt the communication of the victim network intentionally, causing interference or collision at the receiver side. Jamming attack is a well-studied and an active area of research in wireless networks. [9] provides a list of references on wireless networks related to the problem considered in this paper. In contradistinction to the contemporary research on jamming which mainly deals with spectral techniques to initiate as well as mitigate jamming, our current work focuses on mobility as a means to evade the jamming attack within the communication network present among the agents in a team. The effectiveness of a jamming attack depends on the vicinity of the transmitter and receiver from the jammer. This gives rise to various scenarios involving pursuit-evasion games for a mobile jammer in the presence of a mobile transmitter and receiver. Moreover, our previous work in [13] highlights the fact that optimal motion strategies for the receiver and transmitter to evade a jamming attack are difficult to compute in real time. This work is in the same vein with an additional emphasis on efficient approximation techniques that maintain a balance between the complexity and the optimality of the resultant strategies for the agents in the following scenarios; large team size, and partial state information for each agent.

The main contributions of this paper, based on our prior work in [9, 10, 7, 25], are as follows. First, we use a differential game theoretic approach to analyze the

jamming evasion problem in mobile networks, which has never been seen in the pursuit-evasion literature, and provides a novel application domain of significant interest. Second, we extend the current work on connectivity maintenance problems in multi-agent systems to include antagonistic scenarios that might arise due to the presence of an adversary in the vicinity. Third, we address the problem of decentralized decision making in adversarial situations in context of the jamming problem, which is a topic of interest to researchers in the areas of games, control and decision-making.

nodes we used the notion of *state-dependent graphs* to model the problem. Applying tools from algebraic graph theory on the state-dependent graphs provided us with locally optimal control strategies for the agents as well as the jammer. Finally, we proposed two approximation techniques for the agents in the face of decentralized information pattern. First, we assumed that each agent has a knowledge about the value function under perfect state information, beforehand. Due to lack of information about all the agents in the team, each agent is constrained to make a local decision based on the information about his neighbors. We proposed an online algorithm under decentralized information pattern for convergence for each player. We proposed an approximation scheme for the agents based on averaging, and provided bounds on the time of termination for the proposed scheme. Next, we investigated an estimator-based control strategy for a scenario in which the agents have a process noise in addition to the decentralized information structure.

The rest of the paper is organized as follows. Section 2 presents the jamming and communication models for the nodes. Based on the aforementioned models, a multi-player pursuit-evasion game is analyzed in Section 3 between an aerial jammer and a pair of UAVs. Section 4 generalizes the jamming problem introduced in the previous section to address the scenario when there is an arbitrary number of agents/players in the network. Section 5 presents an approximation scheme for the players based on a decentralized information structure. In Section 6, we analyze a discrete-time version of the jamming problem with process noise and decentralized information structure, and propose an estimator-based strategy for the players. Finally, we conclude in Section 7 with some current challenges and future research.

**2. Jamming model.** In this section, we first introduce a communication model between two mobile nodes in the presence of a jammer. Consider a mobile node (*receiver*) receiving messages from another mobile node (*transmitter*) at some frequency. Both communicating nodes are assumed to be lying on a plane. Consider a third node that is attempting to jam the communication channel in between the transmitter and the receiver by sending a high power noise at the same frequency. This kind of jamming is referred to as the *trivial jamming*. A variety of metrics can be used to compare the effectiveness of various jamming attacks. Some of these metrics are energy efficiency, low probability of detection, and strong *denial of service* [50] [48]. In this paper, we use the ratio of the jamming-power to the signal-power (JSR) as the metric. From [53], we have the following models for the JSR ( $\xi$ ) at the receiver's antenna.

1.  $R^n$  model

$$\xi = \frac{P_{J_T} G_{J_R} G_{R_J}}{P_T G_{T_R} G_{R_T}} 10^{n \log_{10} \left( \frac{D_{T_R}}{D_{J_R}} \right)}$$

## 2. Ground Reflection Propagation

$$\xi = \frac{P_{J_T} G_{J_R} G_{R_J}}{P_T G_{T_R} G_{R_T}} \left( \frac{h_J}{h_T} \right)^2 \left( \frac{D_{T_R}}{D_{J_R}} \right)^4$$

## 3. Nicholson

$$\xi = \frac{P_{J_T} G_{J_R} G_{R_J}}{P_T G_{T_R} G_{R_T}} 10^{4 \log_{10} \left( \frac{D_{T_R}}{D_{J_R}} \right)}$$

where  $P_{J_T}$  is the power of the jammer transmitting antenna,  $P_T$  is the power of the transmitter,  $G_{T_R}$  is the antenna gain from transmitter to receiver,  $G_{R_T}$  is the antenna gain from receiver to transmitter,  $G_{J_R}$  is the antenna gain from jammer to receiver,  $G_{R_J}$  is the antenna gain from receiver to jammer,  $h_J$  is the height of the jammer antenna above the ground,  $h_T$  is the height of the transmitter antenna above the ground,  $D_{T_R}$  is the Euclidean distance between transmitter and receiver, and  $D_{J_R}$  is the Euclidean distance between jammer and receiver. All the above models are based on the propagation loss depending on the distance of the jammer and the transmitter from the receiver. In all the above models the jammer to signal ratio is dependent on the ratio  $D_{T_R}/D_{J_R}$ .

For digital signals, the jammer's goal is to raise the ratio to a level such that the *bit error rate* [54] is above a certain threshold. For analog voice communication, the goal is to reduce the articulation performance so that the signals are difficult to understand. Hence we assume that the communication channel between a receiver and a transmitter is considered to be jammed in the presence of a jammer if  $\xi \geq \xi_{tr}$  where  $\xi_{tr}$  is a threshold determined by many factors including application scenario and communication hardware. If all the parameters except the mutual distances between the jammer, transmitter and receiver are kept constant, we can conclude the following from all the above models:

*If  $D_{J_R}/D_{T_R} \leq \eta$  for some positive constant  $\eta$ , then the communication channel between a transmitter and a receiver is considered to be jammed.*

Here  $\eta$  is a function of  $\xi$ ,  $P_{J_T}$ ,  $P_T$ ,  $G_{T_R}$ ,  $G_{R_T}$ ,  $G_{J_R}$ ,  $G_{R_J}$  and  $D_{T_R}$ . Hence if the transmitter is not within a disc of radius  $D_{J_R}/\eta$  centered around the receiver, then the communication channel is considered to be jammed. We call this disc as the *perception range*. The *perception range* for any node depends on the distance between the jammer and the node. For effective communication between two nodes, each node should be able to transmit as well as receive messages from the other node. Hence two nodes can communicate if they lie in each other's *perception range*.

In the rest of the paper, we will use the above jamming and communication model.

**3. Aerial jamming in a UAV communication network.** In this section, we envision a scenario in which an aerial jammer intrudes the communication link between two UAVs. In the past few years, a lot of research has been devoted to deploy multiple UAVs in a decentralized manner to carry out tasks in military as well as civilian scenarios. In general, the mode of communication among UAVs deployed in a team mission is wireless. This renders the communication channel vulnerable to malicious attacks from aerial jammer flying in their vicinity. In the past year, there have been reports of predator drones being hacked [24, 43], resulting in intruders gaining access to classified data being transmitted from an aircraft. Motivated by such incidents, our first scenario addresses the problem of

evading a jamming attack launched by an aerial jammer flying in the vicinity of two UAVs that are trying to mutually communicate among themselves. We model the intrusion as a continuous time pursuit-evasion game between the UAVs and the aerial jammer. Such dynamic games governed by differential equations can be analyzed using tools from differential game theory [40][27]. In the past, differential game theory has been used as a framework to analyze problems in multi-player pursuit-evasion games. Solutions for particular multi-player games were presented by Pashkov and Terekhov [52], Levchenkov and Pashkov [39], Hagedorn and Breakwell [26], Breakwell and Hagedorn [17] and Sriram *et.al.*[56]. More general treatment of multiplayer differential games was presented by Starr and Ho [16], Leitmann [36], Vaisbord and Zhukovskiy [65], Zhukovskiy and Salukvadze [70] and Stipanović, Hovakimyan and Melikyan [62]. The inherent hardness in obtaining an analytical solution to Hamilton-Jacobi-Isaacs equation has led to the development of numerical techniques for the computation of the value function. Recent efforts in this direction to compute an approximation of the reachable sets have been provided by Mitchell and Tomlin [47], Stipanović, Hwang and Tomlin [61] and Stipanović, Sriram and Tomlin [60]. In contrast to the previous work in pursuit-evasion games that formulate a payoff based on a geometric quantity in the configuration space of the system, we formulate a payoff based on the capability of the players in a team to communicate among themselves in the presence of a jammer in their vicinity. In particular, we are interested in computing strategies for spatial reconfiguration of a formation of UAVs in the presence of an aerial jammer to reduce the jamming on the communication channel.

In the following subsection, we describe the kinematic model of the UAVs.

**3.1. System model.** In our analysis, each node is a UAV. We consider two UAVs (UAV<sub>1</sub> and UAV<sub>2</sub>) in the presence of a third UAV (UAV<sub>j</sub>) that is trying to jam the communication link in between them. We assume that the UAVs are having a constant altitude flight. This assumption helps to simplify our analysis to a planar case. Referring to Figure 8, the configuration of each UAV in the global coordinate frame can be expressed in terms of the variables  $(x_i^g, y_i^g, \phi_i^g)$ . The subscript  $i$  is either 1, 2 or  $j$  depending on the UAV being referred. The pair  $(x_i^g, y_i^g)$  represents the position of a reference point on UAV <sub>$i$</sub>  with respect to the origin of the global reference frame and  $\phi_i^g$  denotes the instantaneous heading of the UAV <sub>$i$</sub>  in the global reference frame. Hence the state space for UAV <sub>$i$</sub>  is  $\mathbf{X}_i \cong \mathbb{R}^2 \times \mathbb{S}^1$ . In our analysis, we assume that the UAVs are a kinematic system and hence the dynamics of the UAVs are not taken into account in the differential equation governing the evolution of the system. The kinematics of the UAVs are assumed to be the following:

$$\frac{dx_i^g}{dt} = W_i \cos \phi_i^g; \frac{dy_i^g}{dt} = W_i \sin \phi_i^g; \frac{d\phi_i^g}{dt} = \sigma_i, \quad (1)$$

where  $W_i$  and  $\sigma_i$  are the speed and angular velocity of UAV <sub>$i$</sub> , respectively. In this paper, we assume that  $\sigma_i \in [-1, +1] \quad \forall i$ . Moreover, we assume that  $W_i = 1 \quad \forall i$ .

The state space of the entire system is  $\mathbf{X}_1 \times \mathbf{X}_2 \times \mathbf{X}_j \cong \mathbb{R}^6 \times (\mathbb{S}^1)^3$ . In order to reduce the dimension of the state space we analyze the system in a coordinate frame fixed to UAV<sub>2</sub> as shown in Figure 8. In the new coordinate frame, the system can be modeled using six independent variables and the equations of motion of the UAV<sub>1</sub>

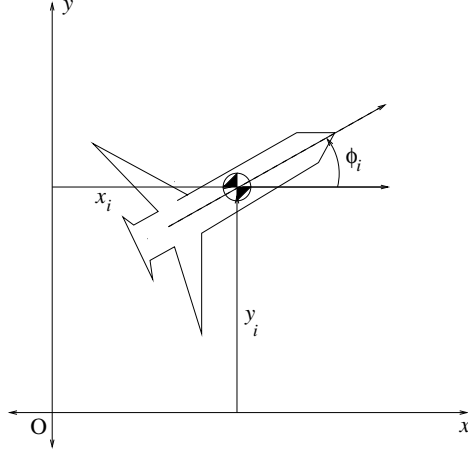

FIGURE 1. Configuration of a UAV

and  $UAV_j$  with respect to the new coordinate frame are given by the following [56]:

$$\underbrace{\begin{pmatrix} \dot{x}_1 \\ y_1 \\ \phi_1 \\ x_2 \\ y_2 \\ \phi_2 \end{pmatrix}}_x = \underbrace{\begin{pmatrix} -1 + \sigma_2 y_1 + \cos \phi_1 \\ -\sigma_2 x_1 + \sin \phi_1 \\ -\sigma_2 + \sigma_1 \\ -1 + \sigma_2 y_j + \cos \phi_j \\ -\sigma_2 x_j + \sin \phi_j \\ -\sigma_2 + \sigma_j \end{pmatrix}}_{f(x, \sigma_1, \sigma_2, \sigma_j)} \quad (2)$$

In the above expressions  $(x_j, y_j, \phi_j)$  and  $(x_1, y_1, \phi_1)$  represent the relative position and orientation of the  $UAV_j$  and  $UAV_1$  in the reference frame attached to  $UAV_2$  which are the state variables of the system. Hence the state space of the reduced system is isomorphic to  $\mathbb{R}^4 \times (S^1)^2$ .

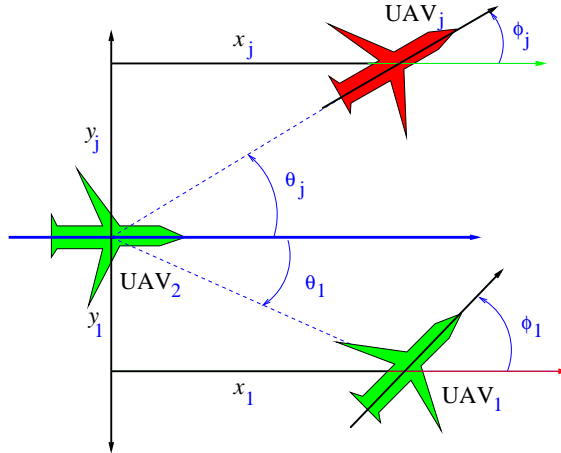

FIGURE 2. Relative configuration of UAVs

**3.2. Problem statement.** From the communication and the mobility models proposed in the previous subsections, we formulate the following problem. Consider a situation in which UAV<sub>1</sub> and UAV<sub>2</sub> are not communicating initially in the presence of a jammer (UAV<sub>j</sub>). The objective of the jammer is to maximize the time for which it can jam the communication between UAV<sub>1</sub> and UAV<sub>2</sub>. The objective of UAV<sub>1</sub> and UAV<sub>2</sub> is to minimize the time for which communication remains jammed. The game terminates at the first instant at which UAV<sub>1</sub> and UAV<sub>2</sub> are in a position to communicate. We need to compute the optimal strategies for each UAV. We assume that each UAV has a complete knowledge about the state of the system.

**3.3. Analysis.** We consider a situation in which UAV<sub>1</sub> and UAV<sub>2</sub> are not communicating initially in the presence of a jammer (UAV<sub>j</sub>). The termination condition is defined as the first instant at which UAV<sub>1</sub> and UAV<sub>2</sub> are in a position to communicate. The cost function of the game is the time of termination of the game. The objective of the jammer is to maximize the time for which it can jam the communication between UAV<sub>1</sub> and UAV<sub>2</sub>. The objective of UAV<sub>1</sub> and UAV<sub>2</sub> collectively is to minimize the time for which communication remains jammed.

In order to obtain the optimal strategies of the players we need to compute the *saddle-point strategies* since this is a zero-sum game. A set of strategies for the players are said to be in *saddle-point equilibrium* if no unilateral deviation in strategy by a player can lead to a better outcome for that player. Hence there is no motivation for the players to deviate from their equilibrium strategies. In scenarios where the players have no knowledge about each other's strategies, equilibrium strategies are important since they lead to a guaranteed minimum outcome for the players in spite of the other player's strategies.

For a point  $\mathbf{x}$  in the state space, let  $J(\mathbf{x})$  represent the outcome if the players implement their optimal strategies starting at the point  $\mathbf{x}$ . In this game, it is the time of termination of the game when the players implement their optimal strategies. It is also called the *value* of the game at  $\mathbf{x}$ . Let  $\nabla J = [J_{x_1} \ J_{y_1} \ J_{\phi_1} \ J_{x_j} \ J_{y_j} \ J_{\phi_j}]^T$  denote the gradient of the value function. The Hamiltonian of the system is given by  $H = 1 + \nabla J \cdot f(\mathbf{x}, \sigma_1^*, \sigma_j^*, \sigma_2^*, t)$ . From the equations of motion of the system, the Hamiltonian is given by the following expression:

$$H = 1 + J_{x_1}\dot{x}_1 + J_{y_1}\dot{y}_1 + J_{\phi_1}\dot{\phi}_1 + J_{x_j}\dot{x}_j + J_{y_j}\dot{y}_j + J_{\phi_j}\dot{\phi}_j$$

Since the jammer wants to maximize the time of termination and the UAV's want to minimize the time of termination, we get the following expressions for the controls from Isaacs' first condition.

$$(\sigma_1^*, \sigma_2^*, \sigma_j^*) = \arg \max_{\sigma_j} \min_{\sigma_2, \sigma_1} H$$

Since the Hamiltonian is separable in its controls, the order of taking the extrema becomes inconsequential. Hence the optimal control of the players are given as follows.

$$\sigma_2^* = -\text{sign}[J_{x_1}y_1 - J_{y_1}x_1 - J_{\phi_1} - J_{\phi_j} - J_{y_j}x_j + J_{x_j}y_j] \quad (3)$$

$$\sigma_j^* = \text{sign}(J_{\phi_j}) \quad (4)$$

$$\sigma_1^* = -\text{sign}(J_{\phi_1}) \quad (5)$$

The *retrogressive path equations* (RPE) for the system lead to the following equations.

$$\dot{J}_{x_1} = -\sigma_2^* J_{y_1}, \quad \dot{J}_{y_1} = \sigma_2^* J_{x_1} \quad (6)$$

$$\dot{J}_{x_j} = -\sigma_2^* J_{y_j}, \quad \dot{J}_{y_j} = \sigma_2^* J_{x_j} \quad (7)$$

$$\dot{J}_{\phi_1} = -J_{x_1} \sin \phi_1 + J_{y_1} \cos \phi_1 \quad (8)$$

$$\dot{J}_{\phi_j} = -J_{x_j} \sin \phi_j + J_{y_j} \cos \phi_j \quad (9)$$

$\dot{\phantom{x}}$  denotes derivative with respect to retrograde time.

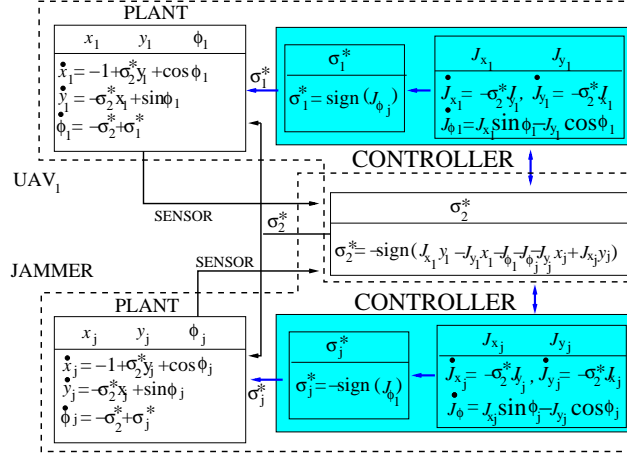

FIGURE 3. The Control Loop for the System

Figure 3 summarizes the entire control algorithm. The controller of each UAV takes as input the state variables and runs the RPE to compute the control. This control is then fed into the plant of the respective UAV. The plant updates the state variables based on the kinematic equations governing the UAV. Finally the sensors feedback the state variables into the controllers. In this case the sensors measure the position and the orientation of each UAV.

**3.4. Termination situations.** In order to compute the optimal strategies, we need to compute the boundary conditions for the dependent variables of the differential equation. In order to do so, we characterize the terminal conditions of the game in the state space and compute the value of  $\nabla J$  at the terminal conditions. This section presents the computation of the terminal value of the dependent variables of the differential equations governing the game.

From the communication model, we can conclude that UAV<sub>1</sub> can communicate with UAV<sub>2</sub> when the following condition holds:

$$\eta \min[d(\text{UAV}_J, \text{UAV}_1), d(\text{UAV}_J, \text{UAV}_2)] \geq d(\text{UAV}_1, \text{UAV}_2)$$

where  $d(\text{UAV}_i, \text{UAV}_j)$  is the Euclidean distance between UAV<sub>i</sub> and UAV<sub>j</sub>. Hence the boundary of the game set is the set of positions of the UAV's that satisfies the following condition:

$$\eta \min[d(\text{UAV}_J, \text{UAV}_1), d(\text{UAV}_J, \text{UAV}_2)] = d(\text{UAV}_1, \text{UAV}_2)$$

This leads to two termination manifolds in the state space.

1. The first terminal manifold is characterized by the positions of the UAV's such that UAV<sub>1</sub> is at the boundary of the *perception range* of UAV<sub>2</sub> and UAV<sub>2</sub> is inside the *perception range* of UAV<sub>1</sub>. In the coordinate system of UAV<sub>2</sub> the terminal manifold is represented by the hypersurface  $F_1(x_1, y_1, \phi_1, x_j, y_j, \phi_j)$  which is given by the following expression:

$$\begin{aligned} & (\sqrt{x_1^2 + y_1^2} - \eta\sqrt{x_j^2 + y_j^2} = 0) \cap \\ & ((x_1 - x_j)^2 + (y_1 - y_j)^2 - (x_j^2 + y_j^2) \leq 0) \end{aligned}$$

2. The second terminal manifold is characterized by the positions of the UAV's such that UAV<sub>2</sub> is at the boundary of the *perception range* of UAV<sub>1</sub> and UAV<sub>1</sub> is inside the *perception range* of UAV<sub>2</sub>. In the coordinate system attached to UAV<sub>2</sub> this terminal manifold is represented by the hypersurface  $F_2(x_1, y_1, \phi_1, x_j, y_j, \phi_j)$  is given by the following expression:

$$\begin{aligned} & (\sqrt{x_1^2 + y_1^2} - \eta\sqrt{x_j^2 + y_j^2} = 0) \cap \\ & ((x_1 - x_j)^2 + (y_1 - y_j)^2 - x_j^2 - y_j^2 \geq 0) \end{aligned}$$

Both the terminal surfaces are five dimensional manifolds with boundary. Hence they can be parameterized using five independent variables  $x_1, y_1, x_j, \phi_1$  and  $\phi_j$ . Since  $J \equiv 0$  on the terminal manifold,  $\nabla J$  satisfies the following equations at an interior point in the manifold:

$$\begin{aligned} J_{x_1}^0 + J_{y_j}^0 \frac{\partial y_j}{\partial x_1} &= 0, & J_{y_1}^0 + J_{y_j}^0 \frac{\partial y_j}{\partial y_1} &= 0 \\ J_{x_j}^0 + J_{y_j}^0 \frac{\partial y_j}{\partial x_j} &= 0, & J_{\phi_1}^0 &= 0, & J_{\phi_j}^0 &= 0 \end{aligned} \quad (10)$$

In addition to the above equations Isaacs' second condition leads to the following equation.

$$H(\mathbf{x}, \nabla J, f(\mathbf{x}, \sigma_1^*, \sigma_2^*, \sigma_j^*)) = 0 \quad (11)$$

The value of  $\nabla J$  at the terminal manifold can be obtained from Equations (11) and (12). Since there are two different terminal manifolds, we have to analyze both of them separately. At first, we compute the value of  $\nabla J$  on terminal manifold 1. Substituting the expression for  $F_1(x_1, y_1, \phi_1, x_j, y_j, \phi_j)$  in Equation (11) and (12), we obtain the following value of  $J_{y_j}$ .

$$J_{y_j}^0 = y_j^0 [\sqrt{(x_j^0)^2 + (y_j^0)^2} (\frac{1}{\eta} - 1) + (x_j^0 - \frac{x_1^0}{\eta^2})]^{-1} \quad (12)$$

From the values of  $\nabla J$ , the optimal control for the players and their higher derivatives at termination are given as follows:

- $\sigma_1^*$ :

$$\sigma_1^* = -\text{sign}(J_{\phi_1}^0)$$

$$J_{\phi_1}^0 = 0$$

$$j_{\phi_1}^0 = 0$$

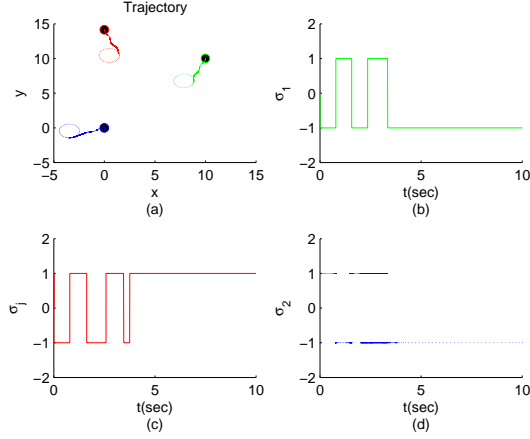

FIGURE 4. Figure shows the players leading to Termination condition 1 for Problem 1. The value  $\eta = 1$ . The player in red is the jammer. The players in green and blue are UAV<sub>1</sub> and UAV<sub>2</sub> respectively. Figure (b) shows the control of the UAV<sub>1</sub>. Figure (c) shows the control of the UAV<sub>j</sub>. Figure (c) shows the control of the UAV<sub>2</sub>.

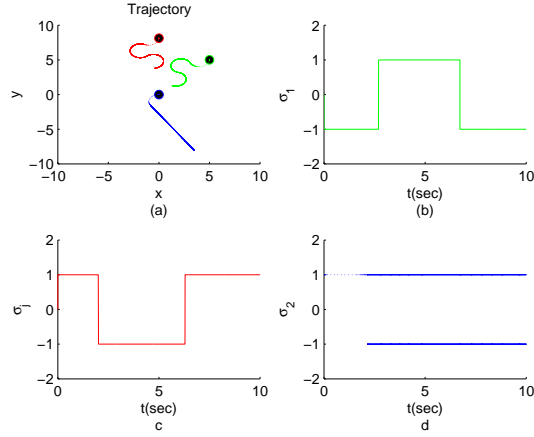

FIGURE 5. Figure shows the players leading to Termination condition 2 for Problem 1. The value  $\eta = 2$ . The player in red is the jammer. The players in green and blue are UAV<sub>1</sub> and UAV<sub>2</sub> respectively. Figure (b) shows the control of the UAV<sub>1</sub>. Figure (c) shows the control of the UAV<sub>j</sub>. Figure (c) shows the control of the UAV<sub>2</sub>.

$$\begin{aligned}
 \ddot{j}_{\phi_1}^0 &= -\frac{\sigma_1^*}{\eta^2} \sqrt{(x_1^0)^2 + (y_1^0)^2} [\sqrt{(x_j^0)^2 + (y_j^0)^2} (\frac{1}{\eta} - 1) + \\
 &\quad (x_j^0 - \frac{x_1^0}{\eta^2})^{-1} \\
 &= \sigma_1^* c_1(\mathbf{x}^0)
 \end{aligned} \tag{13}$$

- $\sigma_j^*$

$$\begin{aligned}\sigma_j^* &= \text{sign}(J_{\phi_j}^0) \\ J_{\phi_j}^0 &= 0 \\ \dot{J}_{\phi_j}^0 &= 0\end{aligned}$$

$$\begin{aligned}\ddot{J}_{\phi_j}^0 &= -\sigma_j^* \sqrt{(x_j^0)^2 + (y_j^0)^2} [\sqrt{(x_j^0)^2 + (y_j^0)^2} (\frac{1}{\eta} - 1) + \\ &\quad (x_j^0 - \frac{x_1^0}{\eta^2})^{-1}] \\ &= \sigma_j^* c_j(\mathbf{x}^0)\end{aligned}\tag{14}$$

- $\sigma_2^*$

$$\begin{aligned}\sigma_2^* &= -\text{sign}[J_{x_1}y_1 - J_{y_1}x_1 - J_{\phi_1} - J_{\phi_j} - J_{y_j}x_j + J_{x_j}y_j] \\ &\quad (J_{x_1}y_1 - J_{y_1}x_1 - J_{\phi_1} - J_{\phi_j} - J_{y_j}x_j + J_{x_j}y_j) = 0 \\ &\quad (J_{x_1}y_1 - J_{y_1}x_1 - J_{\phi_1} - J_{\phi_j} - J_{y_j}x_j + J_{x_j}y_j) = \\ &\quad (y_j^0 - \frac{y_1^0}{\eta^2}) [\sqrt{(x_j^0)^2 + (y_j^0)^2} (\frac{1}{\eta} - 1) + (x_j^0 - \frac{x_1^0}{\eta^2})^{-1}]\end{aligned}\tag{15}$$

From equation (9) we can conclude the following

- $\dot{J}_{\phi_1}^0 > 0 \Rightarrow J_{\phi_1}^0 < 0 \Rightarrow J_{\phi_1}^0 > 0 \Rightarrow \sigma_1^* < 0 \Rightarrow c_1(\mathbf{x}^0) < 0$
- $\dot{J}_{\phi_1}^0 < 0 \Rightarrow J_{\phi_1}^0 > 0 \Rightarrow J_{\phi_1}^0 < 0 \Rightarrow \sigma_1^* > 0 \Rightarrow c_1(\mathbf{x}^0) < 0$

From equation (10) we can conclude the following

- $\dot{J}_{\phi_j}^0 > 0 \Rightarrow J_{\phi_j}^0 < 0 \Rightarrow J_{\phi_j}^0 > 0 \Rightarrow \sigma_j^* > 0 \Rightarrow c_j(\mathbf{x}^0) > 0$
- $\dot{J}_{\phi_j}^0 < 0 \Rightarrow J_{\phi_j}^0 > 0 \Rightarrow J_{\phi_j}^0 < 0 \Rightarrow \sigma_j^* < 0 \Rightarrow c_j(\mathbf{x}^0) > 0$

From the expressions of  $\sigma_1^*$  and  $\sigma_j^*$ , we can conclude that  $\text{sign}(c_1(\mathbf{x}^0)) = \text{sign}(c_j(\mathbf{x}^0))$ . This implies that if at termination  $c_1(\mathbf{x}^0) < 0$  then  $\ddot{J}_{\phi_1} = 0 \Rightarrow \sigma_j^* = 0$  and if  $c_j(\mathbf{x}^0) < 0$  then  $\ddot{J}_{\phi_j} = 0 \Rightarrow \sigma_1^* = 0$ .

Repeating the same analysis at the second terminal manifold leads to the following values for the  $J_{y_j}^0$  and controls at termination.

$$\begin{aligned}J_{y_j}^0 &= (y_j^0 - y_1^0) [\frac{\sqrt{(x_1^0)^2 + (y_1^0)^2}}{\eta^2} + (\sqrt{(x_1^0)^2 + (y_1^0)^2} + \\ &\quad \sqrt{(x_j^0)^2 + (y_j^0)^2}) (\cos(\phi_1^0 - \phi_j^0) - 1) - \frac{x_1^0}{\eta^2}]^{-1}\end{aligned}$$

- $\sigma_1^*$ :

$$\begin{aligned}\sigma_1^* &= -\text{sign}(J_{\phi_1}) \\ J_{\phi_1}^0 &= 0\end{aligned}$$

$$\dot{J}_{\phi_1} = [y_j^0 \cos \phi_1 - x_j^0 \sin \phi_1] p(\mathbf{x}^0)$$

- $\sigma_j^*$ :

$$\begin{aligned}\sigma_j^* &= \text{sign}(J_{\phi_j}) \\ J_{\phi_j}^0 &= 0\end{aligned}$$

$$\dot{J}_{\phi_j} = [y_j^0 \cos \phi_1 - x_j^0 \sin \phi_1] p(\mathbf{x}^0)$$

•  $\sigma_2^*$

$$\begin{aligned} \sigma_2^* &= -\text{sign}[J_{x_1}y_1 - J_{y_1}x_1 - J_{\phi_1} - J_{\phi_j} - J_{y_j}x_j + J_{x_j}y_j] \\ & (J_{x_1}^0y_1^0 - J_{y_1}^0x_1^0 - J_{\phi_1}^0 - J_{\phi_j}^0 - J_{y_j}^0x_j^0 + J_{x_j}^0y_j^0) = 0 \\ & (J_{x_1}^0y_1^0 - J_{y_1}^0x_1^0 - J_{\phi_1}^0 - J_{\phi_j}^0 - J_{y_j}^0x_j^0 + J_{x_j}^0y_j^0) = \\ & \quad -\frac{y_1}{\eta^2}p(\mathbf{x}^0) \end{aligned}$$

$$\text{where } p(\mathbf{x}^0) = \left[ \frac{\sqrt{(x_1^0)^2 + (y_1^0)^2}}{\eta^2} + \sqrt{(x_j^0)^2 + (y_j^0)^2}(\cos(\phi_1^0 - \phi_j^0) - 1) - \frac{x_1^0}{\eta^2} \right]^{-1}$$

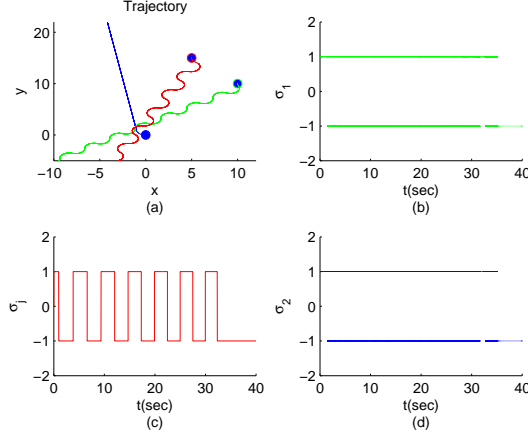

FIGURE 6. Figure shows the players leading to Termination condition 1 for Problem 2. The value  $\eta = 2$ . The player in red is the jammer. The players in green and blue are UAV<sub>1</sub> and UAV<sub>2</sub> respectively. Figure (b) shows the control of the UAV<sub>1</sub>. Figure (c) shows the control of the UAV<sub>2</sub>. Figure (d) shows the control of the jammer.

**3.5. Results.** Figures 4, 5, 6 and 7 show trajectories of the players along with their optimal controls for various terminal conditions and different values of  $\eta$ . The position of the players corresponding to the termination situation is shown by a small circle in the plots showing the trajectories of the players. Each figure shows the trajectory of the players just before termination for a small time interval. From the expression of the optimal controls in equations (4), (5) and (6), we can infer that the controls of the players are bang-bang. This is also verified from the simulation results. From the nature of the controls and kinematics of the system, we can infer that the optimal paths comprise of arcs of circles and straight line trajectories as motion primitives. Arcs of circles are generated when the UAV keeps its angular velocity saturated at one extrema for a non-zero interval of time. Straight line segments are obtained due to rapid switching between the extremal value of the controls (chattering). An instance of such a behavior is exhibited by UAV<sub>2</sub> in Figure 4.

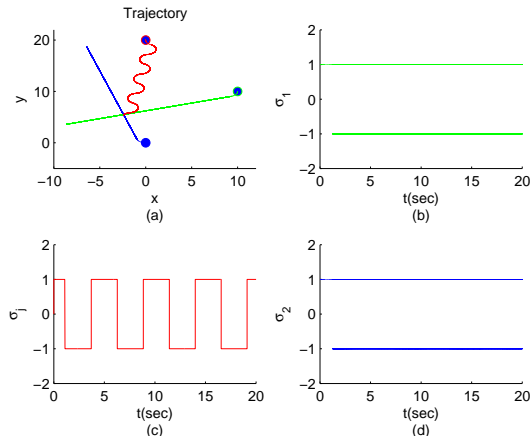

FIGURE 7. Figure shows the players leading to Termination condition 2 for Problem 2. The value  $\eta = 1$ . The player in red is the jammer. The players in green and blue are UAV<sub>1</sub> and UAV<sub>2</sub> respectively. Figure (b) shows the control of the UAV<sub>1</sub>. Figure (c) shows the control of the UAV<sub>J</sub>. Figure (d) shows the control of the UAV<sub>2</sub>.

**4. Connectivity maintenance in the presence of an adversary.** Next, we investigate the problem of jamming in a mobile network having an arbitrary number of agents, and analyze it from the perspective of maintaining connectivity in a network of mobile agents in the presence of a mobile intruder. Substantial research has been done in the recent past to address the problem of maintaining connectivity among autonomous agents. Based on tools from potential field methods and algebraic graph theory, centralized algorithms have been proposed in [68] and [66] to maintain connectivity in mobile networks. The authors use the dynamics of the Laplacian matrix in order to obtain feasible controls that maintain connectivity in addition to satisfying the differential constraints on the motion of each agent. In [58], the notion of *geometric connectivity robustness* is introduced as a measure of the local connectedness of a network. Furthermore, the authors show that under special conditions the new notion provides a sufficient condition for global connectivity of the network. In [31], the authors use the weighted graph Laplacian technique proposed in [30] to guarantee connectivity while achieving formation stabilization. In [21], a decentralized algorithm is presented for maintaining connectivity using the Laplacian of the proximity graph. In [23], the problem of maintaining connectivity is addressed for agents having second-order dynamics. The authors establish an existence theorem for connectivity maintenance and present optimal controls to maintain connectivity in a distributed fashion. In [67], [69], the authors propose a distributed feedback and *provably correct* control framework for connectivity maintenance in addition to accounting for communication delays as well as collision avoidance. In [32], verification for the correctness of the asynchronous and parallel computation proposed in [67] is provided by experimental analysis on a team of robots. Most of the prior work deals with the problem of maintaining connectivity due to the distributed architecture of sensing and communication in multi-agent

systems, which provides increased efficiency, performance, scalability and robustness. In contradistinction, this section focuses on maintaining connectivity for a network within an arbitrary number of mobile agents in the presence of a mobile jammer in the vicinity.

We assume that there are  $m$  agents in the network in the presence of a jammer. Let the dynamics associated with the  $i$ th agent be given by the following equation:

$$\dot{x}_i = f_i(x_i, u_i) \quad (16)$$

where,  $x_i \in \mathbb{R}^{n_i}$ ,  $u_i \in \mathcal{U}_i \simeq \{\phi : [0, t] \rightarrow \mathcal{A}_i \mid \phi(\cdot) \text{ is measurable}\}$ , where  $\mathcal{A}_i \subset \mathbb{R}^{p_i}$ .  $f_i : \mathbb{R}^{n_i} \times \mathcal{A}_i \rightarrow \mathbb{R}$  is uniformly continuous, bounded and Lipschitz continuous in  $x_i$  for fixed  $u_i$ . Consequently, given a fixed  $u_i(\cdot)$  and initial point, there exists a unique trajectory solving (16) [1]. Let the state of node  $i$  be denoted as  $x_i \in \mathbf{X}_i \subset \mathbb{R}^{n_i}$ .

Let  $\mathbf{X}_\bullet$  denote the state-space of the jammer. We assume that the jammer has the following dynamics associated with itself:

$$\dot{x}_\bullet = f_\bullet(x_\bullet, u_\bullet) \quad (17)$$

where  $x_\bullet \in \mathbb{R}^{n_\bullet}$ ,  $u_\bullet \in \mathcal{U}_\bullet \simeq \{\phi : [0, t] \rightarrow \mathcal{A}_\bullet \mid \phi(\cdot) \text{ is measurable}\}$ , where  $\mathcal{A}_\bullet \subset \mathbb{R}^{p_\bullet}$ .  $f_\bullet : \mathbb{R}^{n_\bullet} \times \mathcal{A}_\bullet \rightarrow \mathbb{R}$  is uniformly continuous, bounded and Lipschitz continuous in  $x_\bullet$  for fixed  $u_\bullet$ .

Let  $\mathbf{X} = \mathbf{X}_1 \times \cdots \times \mathbf{X}_m \times \mathbf{X}_\bullet \subset \bigoplus_i \mathbb{R}^{n_i} \times \mathbb{R}^{n_\bullet}$  represent the entire state of the system, where,  $\bigoplus$  represents the Cartesian product of the Euclidean spaces  $\mathbb{R}^{n_i}$ . Let  $u = [u_1^T \cdots u_m^T]^T$  be a column vector that represents the control of all the agents in the network.

We define the *workspace* [19] as the ambient space in which the agents exist. Since we are interested in vehicular networks, the ambient space of the nodes is either  $\mathbb{R}^2$  or  $\mathbb{R}^3$ . Since all the agents reside in the same ambient space, we use  $\Omega$  to denote the workspace for all agents. Let  $\bar{x}_i$  denote the coordinates of the  $i$ th agent in  $\Omega$ . We assume that  $\Omega$  is equipped with a distance metric  $\rho : \Omega \times \Omega \rightarrow \mathbb{R}$ .

As a simple example to highlight the difference between the state space and the workspace, consider the following second order agent that can only move in a straight line with  $u$  as the control input.

$$\begin{aligned} \dot{x}_1 &= x_2 \\ \dot{x}_2 &= u \end{aligned}$$

The state space for the system can be represented by the vector  $x = [x_1 \ x_2]^T$ . The state space is two dimensional but the agent can only move on a straight line and hence the workspace is  $\Omega = \mathbb{R}^1$ . For any state  $x$ ,  $\bar{x} = x_1$ . For two states  $x^*, x^{**} \in \Omega$ ,  $\rho(\bar{x}^*, \bar{x}^{**}) = |x_1^* - x_1^{**}|$ .

Based on the above definitions, the network connectivity maintenance problem is formulated as the following zero-sum differential game between the jammer and the nodes in the network.

G1: *Consider a situation in which the network is initially connected in the presence of a jammer. The instantaneous states of all the agents and the jammer are known to all the players till termination of the game. The objective of the jammer is to minimize the time in which it can disconnect the communication network by jamming the communication channel between agents. The objective of agents is to maximize the time for which communication link between them remains operable. The game terminates at the first instant at which the agents are about to lose their links. We need to compute the optimal strategies for each agent. Disconnection*

refers to a situation in which there are agents  $i$  and  $j$  such that there is no path in the communication network to transmit messages between them.

As in the previous section, we want to compute the *saddle-point strategies* of the players in the game. In [12], we have analysed the scenario of multiple jammers and multiple UAVs flying in a formation. We analyzed the problem in the framework of differential game theory, and provided analytical and approximate techniques to compute non-singular motion strategies of the UAVs. Analytical solutions to the associated Hamilton-Jacobi-Bellman-Isaacs equations becomes extremely difficult to compute as the number of players. Moreover, the non-linearity present in the dynamical equations of the players makes it difficult to obtain an analytical solution to the optimal control problem addressed by the Isaacs' conditions. Many computational techniques have been proposed to compute the optimal trajectories for such problems but they are computationally intensive even for systems evolving in low dimensions [47], [61], [60].

Due to the inherent difficulty in solving the above differential game, we propose a greedy strategy for the agents. In the following sections, we model the connectivity of the network as a graph, and formulate a cost function based on it.

**4.1. State-dependent graphs.** In this section, we model the underlying communication network within the agents as a graph. The connectivity of the network depends on the position of the agents relative to the jammer. Since the agents and the jammer are assumed to be mobile, the connectivity of the network evolves in time rendering the graph to be dynamic in nature. Moreover, topology of the graph depends on the state of the nodes and therefore, we can use the framework of state-dependent graphs introduced in [46] to map the state of the system to a graph. A state-dependent graph is a mapping,  $g_c$ , from the state space  $\mathbf{X}$ , to the set of all labeled graphs on  $m$  vertices,  $G(m)$ , i.e.,

$$g_c : \mathbf{X} \rightarrow G(m)$$

Node  $i$  in the graph represents agent  $i$ . It is assumed that the order of these graphs at all times is  $m$  since the number of agents is independent of time. Let  $E(g_c(x))$  denote the edge-set of the graph under consideration. Now we specify how the existence of a communication link dictates the existence of an edge between a pair of vertices in the state-dependent graph  $G$ . For nodes  $i$  and  $j$  with states  $x_i \in \mathbf{X}_i$  and  $x_j \in \mathbf{X}_j$  respectively, we consider the subset  $S_{ij} \subset \mathbf{X}_i \times \mathbf{X}_j$  to define the edge between  $i$  and  $j$  if the following condition is satisfied:

$$ij \in E(g_c(x)) \quad \text{if and only if} \quad (x_i, x_j) \in S_{ij} \quad (18)$$

The jamming model proposed in Section II leads to the following definition of  $S_{ij}$ . Let  $d = \rho(\bar{x}_i, \bar{x}_j)$ , where  $\bar{x}_i$  and  $\bar{x}_j$  are the coordinates of the nodes  $i$  and  $j$  in the workspace  $\Omega$  equipped with a distance metric  $\rho$ . Let  $B_r[p] = \{y \in \Omega \mid \rho(y, p) \leq r\}$ . From the above discussion we can conclude the following:

$$S_{ij} = \{(x_i, x_j) \mid \bar{x}_\bullet \notin B_{\eta d}[\bar{x}_i] \cup B_{\eta d}[\bar{x}_j]\} \quad (19)$$

The above statement along with (18) means that if the jammer lies within a distance  $\eta d$  from either of the nodes then the communication channel is assumed to be jammed. The collection of edge states is denoted as

$$\mathcal{S} = \{S_{ij}\}_{i,j \in [N], i \neq j} \quad \text{with} \quad S_{ij} \subset \mathbf{X}_i \times \mathbf{X}_j$$

From [46], the state dependent graph is defined as follows:

*Definition:* Given the set system  $\mathcal{S}$ , the map  $g_c : \mathbf{X} \rightarrow G_m$  with an image consisting of graphs of order  $m$ , having an edge between vertex  $i$  and  $j$  iff  $(x_i, x_j) \in S_{ij}$  is defined as a state-dependent graph with respect to  $\mathcal{S}$ .

Now that we have a mapping  $g_c$  from the state of the system to a graph on  $m$  vertices, we can study the properties of the graphs based on the state of the system.

**4.2. Dynamic networks.** In this section, we present control strategies for connectivity maintenance based on the algebraic properties of graphs that quantify the connectivity of the underlying communication network. In order to do so, we need to define the following mathematical objects associated with a graph  $G$  having  $m$  nodes:

1. Adjacency matrix : It is an  $m \times m$  matrix with entries given as follows:

$$a_{ij} = \begin{cases} 1 & \text{if an edge exists between } i \text{ and } j \\ 0 & \text{if no edge exists between } i \text{ and } j \end{cases}$$

2. Laplacian of a graph ( $\mathcal{L}(G)$ ) : It is an  $m \times m$  matrix with entries given as follows:

$$\begin{aligned} \text{(a) } a_{ij} &= \begin{cases} -1 & \text{if an edge exists between } i \text{ and } j \\ 0 & \text{if no edge exists between } i \text{ and } j \end{cases} \\ \text{(b) } a_{ii} &= -\sum_{k=1, k \neq i}^m a_{ik} \end{aligned}$$

In a dynamic network, since  $G$  is a function of  $\mathbf{x} \in \mathbf{X}$ , its adjacency matrix is also a function of the state  $\mathbf{x}$ . Let  $\mathbf{A}(\mathbf{x})$  denote the adjacency matrix of the graph  $G$ . The element  $a_{ij} = 1$  if an edge exists between nodes  $i$  and  $j$  or else it is zero  $\implies a_{ij} = 1$  iff  $(x_i, x_j) \in S_{ij}$ . Let  $d_i = \rho(\bar{x}_\bullet, \bar{x}_i)$ ,  $d_j = \rho(\bar{x}_\bullet, \bar{x}_j)$  and  $d_{ij} = \rho(\bar{x}_i, \bar{x}_j)$ .

Changes in  $\mathbf{A}(\mathbf{x})$  occur at discrete points in time. On the other hand, the dynamics of the nodes and the jammer are continuous in time. In order to relate the discrete nature of  $\mathbf{A}(\mathbf{x})$  to the continuous-time dynamics of the nodes we use the following continuous approximation for  $a_{ij}$ :

$$a_{ij}(\mathbf{x}) = \hat{u}(d_i - \eta d_{ij}) \cdot \hat{u}(d_j - \eta d_{ij})$$

where  $\hat{u}(\cdot)$  is a continuous approximation to the Heavyside step function given by the following logistic function:

$$\hat{u}(y) = \frac{1}{1 + e^{-ky}}$$

As  $\lim_{k \rightarrow \infty}$ , the logistic function takes the following form:

$$\hat{u}(y) = \begin{cases} 1 & y \geq 0 \\ 0 & \text{otherwise} \end{cases}$$

Hence  $k$  can be used as a parameter to vary the rate at which the exponential function decays in the neighborhood of zero. The dynamics of the  $a_{ij}(\mathbf{x})$  can be written as follows:

$$\dot{a}_{ij}(\mathbf{x}) = \nabla_{\mathbf{x}} a_{ij}(\mathbf{x}) \cdot \dot{\mathbf{x}} \quad (20)$$

where  $\nabla_{\mathbf{x}} a_{ij}(\mathbf{x})$  denotes the  $mn \times 1$  vector which is the gradient of  $a_{ij}(\mathbf{x})$  w.r.t  $\mathbf{x}$ .

The second-smallest eigenvalue of  $\mathcal{L}(G)$  is called the *Fiedler value*, denoted as  $\lambda_2(\mathcal{L}(G))$ . It is also called the algebraic connectivity of  $G$ . It has emerged as an important parameter in many systems problems defined over networks. In [22], [49], [29], it has also been shown to be a measure of the stability and robustness of the

networked dynamic system. Since this work deals with connectivity maintenance in the presence of a malicious intruder  $\lambda_2(\mathcal{L}(G))$  arises as a natural parameter of interest for both players.

For a graph  $G$  to be connected,  $\lambda_2(\mathcal{L}(G)) > 0$  [14]. Therefore, in order to maintain connectivity, the nodes in the network must move in the presence of a jammer so as to satisfy the above condition. On the other hand, the jammer must move in a way to make  $\lambda_2(\mathcal{L}(G)) = 0$ . In the remaining part of this section, we assume that the network is initially connected.

From the above discussion a control law can be designed for the nodes so as to keep  $\lambda_2(\mathcal{L}(G))$  a non-decreasing function of time  $\implies \frac{\partial(\lambda_2(\mathcal{L}(G)))}{\partial t} \geq 0$ . Since  $\frac{\partial(\lambda_2(\mathcal{L}(G)))}{\partial t}$  is also a function of the controls of the jammer it might not be possible for the nodes to satisfy the above condition at all times. Instead the following objective leads to a feasible control for the nodes at all times:

$$\text{Maximize : } \frac{\partial(\lambda_2(\mathcal{L}(G)))}{\partial t} \quad (21)$$

On the other hand, the jammer must move in a way so as to make  $\lambda_2(\mathcal{L}(G)) = 0$ . Therefore, a plausible strategy for the jammer is keep  $\lambda_2(\mathcal{L}(G))$  a decreasing function at all times. As in the previous case such an objective might not lead to a feasible control strategy at all times. Therefore, the jammer can have the following objective in order to yield a feasible control at all times:

$$\text{Minimize : } \frac{\partial\lambda_2(\mathcal{L}(G))}{\partial t} \quad \text{if } \lambda_2 \neq 0 \quad (22)$$

Since  $\mathcal{L}(G)$  is a symmetric positive semi-definite matrix, all its eigenvalues are non-negative. Therefore the jammer cannot decrease  $\lambda_2(\mathcal{L}(G))$  once it reaches 0. This leads to the additional constraint in its objective.

In order to satisfy the above objective for the players we need a relation between the control of the agents and  $\frac{\partial\lambda_2(\mathcal{L}(G))}{\partial t}$ . Since  $\lambda_2(\mathcal{L}(G))$  is a function of the relative positions of the agents in a network we can get a relation between  $\lambda_2(\mathcal{L}(G))$  and the  $u_i$ . From [28], we obtain the following expression:

$$\frac{\partial\lambda_2(\mathcal{L}(G))}{\partial \mathcal{L}} = \frac{v_2 v_2^T}{v_2^T v_2} \quad (23)$$

where  $v_2$  is the eigenvector corresponding to the  $\lambda_2(\mathcal{L}(G))$ .

Consider agent  $i$  having state  $x_i \in \mathbb{R}^{n_i}$ . Let  $x_i = [x_i^{(1)}, \dots, x_i^{(n_i)}]^T$ . Let  $f_i = [f_i^{(1)}, \dots, f_i^{(n_i)}]^T$ . We can use the chain rule to obtain the following expression:

$$\frac{\partial\lambda_2(\mathcal{L}(x))}{\partial x_i^{(k)}} = \left\langle \frac{\partial\lambda_2(\mathcal{L})}{\partial \mathcal{L}}, \frac{\partial \mathcal{L}}{\partial x_i^{(k)}} \right\rangle f_i^{(k)}(x_i^{(k)}, u_i) \quad (24)$$

where,  $\langle A, B \rangle \triangleq \text{tr}(A^T B)$ , an inner product for the space of matrices. Hence we obtain the following relation between  $\frac{\partial\lambda_2(\mathcal{L}(G))}{\partial t}$  and the control  $u_i$  of each agent:

$$\begin{aligned} \frac{\partial\lambda_2(\mathcal{L}(G))}{\partial t} &= \sum_{i=1}^m \sum_{k=1}^{n_i} \left\langle \frac{\partial\lambda_2(\mathcal{L})}{\partial \mathcal{L}}, \frac{\partial \mathcal{L}}{\partial x_i^{(k)}} \right\rangle f_i^{(k)}(x_i^{(k)}, u_i) + \\ &\quad \sum_{k=1}^{n_\bullet} \left\langle \frac{\partial\lambda_2(\mathcal{L})}{\partial \mathcal{L}}, \frac{\partial \mathcal{L}}{\partial x_\bullet^{(k)}} \right\rangle f_j^{(k)}(x_\bullet^{(k)}, u_\bullet) \end{aligned}$$

Therefore, a locally optimal control law for the agents is a solution of the following optimization problem:

1. Node  $i$ :  $u_i^* = \max_{u_i} \sum_{k=1}^{n_i} \langle \frac{\partial \lambda_2(\mathcal{L})}{\partial \mathcal{L}}, \frac{\partial \mathcal{L}}{\partial x_i^{(k)}} \rangle f_i^k(x_i^{(k)}, u_i)$
2. Jammer:  $u_\bullet^* = \min_{u_\bullet} \sum_{k=1}^{n_\bullet} \langle \frac{\partial \lambda_2(\mathcal{L})}{\partial \mathcal{L}}, \frac{\partial \mathcal{L}}{\partial x_\bullet^{(k)}} \rangle f_j^k(x_\bullet^{(k)}, u_\bullet)$

In the next section, we present some simulations based on the above control law for the agents.

**4.3. Results.** We consider a network of agents moving in a plane in the vicinity of a jammer. All the agents, including the jammer, are holonomic kinematic agents with fixed speeds. The differential equation governing the motion of agent  $i$  is as follows:

$$\begin{aligned} x_i &= u_i \cos \theta_i \\ y_i &= u_i \sin \theta_i \end{aligned}$$

The differential equation governing the motion of the jammer is as follows:

$$\begin{aligned} x_\bullet &= u_\bullet \cos \theta_\bullet \\ y_\bullet &= u_\bullet \sin \theta_\bullet \end{aligned}$$

Using the control laws from the previous section, we obtain the following controls for the agents and the jammer:

1. Node  $i$ :

$$(\cos \theta_i, \sin \theta_i) \parallel \left( \left\langle \frac{\partial \lambda_2(\mathcal{L})}{\partial \mathcal{L}}, \frac{\partial \mathcal{L}}{\partial x_i} \right\rangle, \left\langle \frac{\partial \lambda_2(\mathcal{L})}{\partial \mathcal{L}}, \frac{\partial \mathcal{L}}{\partial y_i} \right\rangle \right)$$

2. Jammer:

$$(\cos \theta_\bullet, \sin \theta_\bullet) \parallel - \left( \left\langle \frac{\partial \lambda_2(\mathcal{L})}{\partial \mathcal{L}}, \frac{\partial \mathcal{L}}{\partial x_\bullet} \right\rangle, \left\langle \frac{\partial \lambda_2(\mathcal{L})}{\partial \mathcal{L}}, \frac{\partial \mathcal{L}}{\partial y_\bullet} \right\rangle \right)$$

Figures 8 and 9 show simulations for 20 agents ( $m = 20$ ) for which the above control scheme is implemented. In Figure 8, the speed of all the agents is same as that of the jammer. In Figure 9, the speed of  $i$ th agent is  $u_\bullet + \frac{(i-1)}{m} - 0.5$ . The simulations are run till the jammer succeeds in disconnecting the network for the first time. Figures 8(a) and 9(a) show the Frobenius norm of the error in approximating the Laplacian matrix as a function of time. Figures 8(b) and 9(b) show the variation of the Fiedler value with time.

Until now, we assumed that at each instant all the agents had a complete knowledge about the entire state of the system. In order for this to be possible, each agent has to continuously communicate its state information to all the other agents. This can lead to a congestion in the communication network of the formation leading to unwanted delay in information dissemination. In the following sections, we present strategies for each agent based on limited state information about other agents in the network.

## 5. Decentralized decision making due to communication constraints.

In this section, we investigate decentralized techniques for maintaining connectivity among agents in the presence of a mobile jammer in the vicinity. In the past, derivation of distributed algorithms for the computation of non-cooperative equilibria of certain classes of games has been addressed in [4, 41]. It has been shown in these

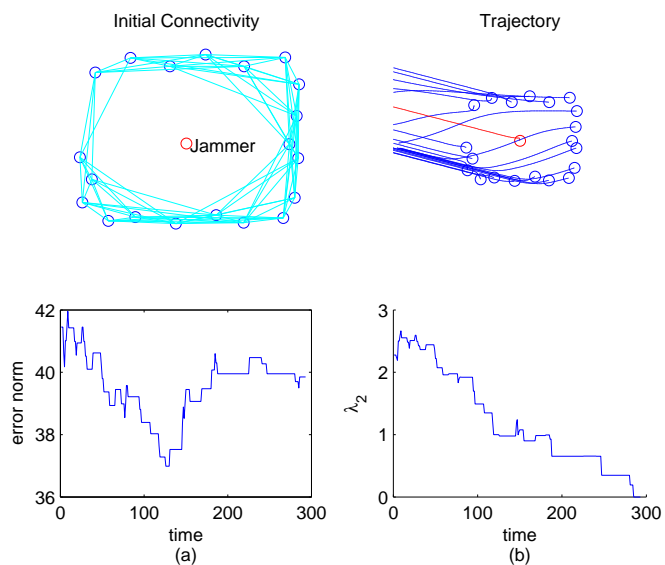

FIGURE 8.

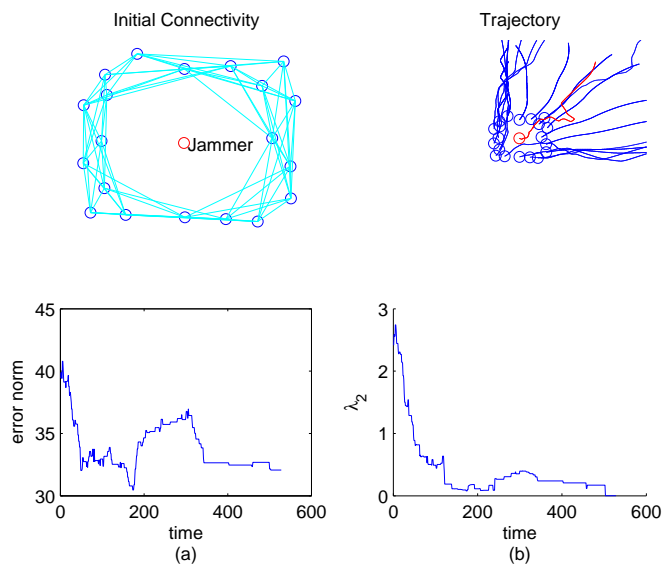

FIGURE 9.

papers that when the cost function is convex or if the system is linear with quadratic cost, then the policy iteration algorithm converges to the Nash equilibrium. In the absence of centralized information, decentralized decision making has been proven to be intractable for discrete static team decision problems [51, 64, 3]. Some approximation schemes are available for discrete team decision problems under limited information [20]. However, there has been limited work on solving differential game problems under limited information [18]. In this section, we consider a scenario in

which each agent makes a decision based on a limited information available to it regarding other agents in the network. Additionally, we assume that each agent has a knowledge about the value function of the game addressed in the previous section, under perfect state information, beforehand. Due to lack of information about all the agents in the team each agent is constrained to make a local decision. We propose a decentralized algorithm for each agent, and provide a bound on its performance compared to the optimal solution obtained under a centralized information pattern.

We investigate two different approximation schemes for the agents. In the first scheme, we assume that each agent has a knowledge about the solution of the game under the assumption that the information pattern is centralized. Based on this solution, the players devise averaging schemes in order to approximate their optimal control actions.

In the previous section, we introduced the following connectivity maintenance game:

*G1: Consider a situation in which the network is initially connected in the presence of a jammer. The instantaneous states of all the agents and the jammer are known to all the players till termination of the game. The objective of the jammer is to minimize the time in which it can disconnect the communication network by jamming the communication channel between agents. The objective of agents is to maximize the time for which communication link between them remains operable. The game terminates at the first instant at which the agents are about to lose their links. We need to compute the optimal strategies for each agent. Disconnection refers to a situation in which there are agents  $i$  and  $j$  such that there is no path in the communication network to transmit messages between them.*

In the present work, we make the following assumptions:

1. We assume that all the agents have an a priori knowledge of the value of the game  $G1$ . We refer to this as the *value map* since the techniques proposed in this work require every agent to use this information for navigation. The value at a state  $\mathbf{x} \in \mathbf{X}$  is denoted as  $J(\mathbf{x})$ . In addition, we assume the dynamics of the agents to be decoupled. Moreover, each agent computes its optimal control using the following expression:

$$\mathbf{u}_i^*(\mathbf{x}(t)) = \arg \max_{\mathbf{u}_i} (1 + J_{\mathbf{x}_i} \cdot f_i(\mathbf{x}_i, \mathbf{u}_i)) \quad (25)$$

2. We assume that agent  $i$  broadcasts  $X_i(t)$  at all times.
3. Due to the presence of a jammer in the vicinity, an agent might lack state information about the other agents as the game proceeds. Therefore, we assume that each agent has state information only regarding those agents from which it receives the broadcast signals.
4. The jammer executes its optimal control since it is assumed that the jammer has complete knowledge of  $\mathbf{X}(t)$  at all times.

From the last assumption, we can infer that an agent  $i$  has an accurate knowledge of  $X_j(t)$  iff  $i$  lies in the perception range of agent  $j$  at time  $t$ . Therefore, at time  $t$ , the state information available to each agent can be expressed as a directed graph,  $I(t) = (V, E(t))$  where,  $V = \{v_1 \cdots v_m, v_\bullet\}$  and  $E(t) = \{\overrightarrow{v_i v_j} | j \text{ is in the perception range of } i\}$ . Since the agents as well as the jammer are mobile,  $I$  is a function of  $t$  and therefore, a dynamic graph [45]. We define the neighborhood of  $i$  in  $I$  as  $N_i^j(t) = \{j | \overrightarrow{v_j v_i} \in E(t)\}$ .

All the aforementioned assumptions are motivated from our previous works in [10, 11, 9, 8] regarding jamming in formation of UAVs and multi-agent systems. In the following subsection, we propose an approximation scheme under a decentralized information pattern that uses the value map for the agents to formulate their optimal control laws in such scenarios.

**5.1. Approximation scheme.** In this section, we introduce an approximation scheme for agents to compute their controls. These control laws are based on the value of the game under full-state information structure.

If each agent had a perfect knowledge of  $\mathbf{X}(t)$  then it could compute  $\mathbf{u}_i^*(t)$  using (25). Due to the presence of a jammer, the state information available to agent  $i$  is restricted to  $N_I^i(t)$ . Based on this information, at time  $t$ , the system can lie on any point on a manifold,  $\mathcal{M}_{N_I^i}$ , given by the following expression:

$$\mathcal{M}_{N_I^i} = \{\mathbf{x} \in \mathbf{X} | X_k = X_k(t), \quad \forall k \in N_I^i(t)\}$$

For each  $\mathbf{x} \in \mathcal{M}_{N_I^i}$ , agent  $i$  can compute  $\mathbf{u}_i^*(\mathbf{x})$  using (25) and the value map. Since the agent  $i$  lacks perfect information about  $\mathbf{X}(t)$  on  $\mathcal{M}_{N_I^i}$ , it cannot compute  $\mathbf{u}_i^*(\mathbf{x}(t))$ .

Now we present a decentralized approximation scheme that uses averaging in order to compute the control law for each agent. In this strategy, agent  $i$  computes the average of the vector  $\mathbf{u}_i^*(\mathbf{x})$  over the entire manifold  $\mathcal{M}_{N_I^i}$  in order to obtain its control. The average,  $\bar{\mathbf{u}}_i$ , on  $\mathcal{M}_{N_I^i}$  is given by the following expression:

$$\bar{\mathbf{u}}_i = \frac{\int_{\mathcal{M}_{N_I^i}} \mathbf{u}_i^*(\mathbf{x}) \cdot d\mathbf{x}}{\int_{\mathcal{M}_{N_I^i}} \mathbf{1}} \quad (26)$$

We assume that  $\bar{\mathbf{u}}_i \in \mathcal{U}(t)$ . This restricts the models of the agents for which our analysis is applicable. From the definition of  $\mathcal{M}_{N_I^i}$ , we can see that it is a submanifold of  $\mathbb{R}^{nm-|N_I^i|-1}$ . Moreover, since we assume that  $\mathbf{X}(0)$  is known and the maximum control of each agent is bounded,  $\mathcal{M}_{N_I^i}$  can be estimated to be a bounded and compact submanifold. Therefore, we can perform the integration in the numerator by assuming  $\mathbf{u}_i^*(\mathbf{x})$  to be an appropriate  $n$ -form on the charts comprising the atlas chosen on  $\mathcal{M}_{N_I^i}$ . In the simplest case when  $\mathcal{M}_{N_I^i}$  is Euclidean, the  $n$ -form is given by  $d\mathbf{x} = dx^1 \cdots dx^{mn}$ . The denominator is also called the volume of the submanifold. In the simplest case when  $\mathcal{M}_{N_I^i}$  is 2-dimensional, it is the area of the submanifold embedded in the higher dimensional space. An inherent assumption made in the above definition is that  $\mathcal{M}_{N_I^i}$  is orientable. In case  $\mathcal{M}_{N_I^i}$  is not Euclidean, the integration can be performed over *singular chains* [59].

From an initial state  $\mathbf{x} \in \mathbf{X}$ , the time of termination of the game when all the agents follow the approximation scheme is denoted as  $\mathcal{T}(\mathbf{x})$ .

**Theorem 5.1.** *If following assumptions hold:*

1.  $\|J_{\mathbf{x}_i}\|_2 \leq \alpha, \quad \forall \mathbf{x}_i$
2.  $\|\mathbf{u}_i(x)\| \leq \frac{\beta}{2}, \quad \forall i$
3.  $f(\mathbf{x}_i, \mathbf{u}_i)$  is Lipschitz in  $\mathbf{u}_i$  with Lipschitz constant  $K$  for all  $\mathbf{x}_i$ .
4.  $\mathcal{M}_{N_I^i}$  is a Euclidean manifold

*Then the termination time of the game obeys the following condition:*

$$J(\mathbf{x}_0) \leq \mathcal{T}(\mathbf{x}_0) \leq \frac{J(\mathbf{x}_0)}{(1-\delta)} \quad (27)$$

where  $\delta = mK\alpha\beta$ .

*Proof.* The rate of change of the value function at time  $t$  along the trajectory traced when the players follow the approximation scheme is given by the following expression:

$$\dot{J}_{app}(t) = \sum_{i \in [1, \dots, m]} J_{\mathbf{x}_i(t)} \cdot f(\mathbf{x}_i(t), \bar{\mathbf{u}}_i) + J_{\mathbf{x}_\bullet} \cdot f(\mathbf{x}_\bullet(t), \mathbf{u}_\bullet^*) \quad (28)$$

In the above expression, the jammer uses its optimal control since it can be computed from the value map due to the assumption that the jammer has a complete state information at all times. From the definition of the value of the game and  $\mathbf{u}_i^*$ , the rate of change of  $J$  at time  $t$  is given by the following expression:

$$\dot{J}(t) = \sum_{i \in [1, \dots, m]} J_{\mathbf{x}_i(t)} \cdot f(\mathbf{x}_i(t), \bar{\mathbf{u}}_i^*) + J_{\mathbf{x}_\bullet(t)} \cdot f(\mathbf{x}_\bullet(t), \mathbf{u}_\bullet^*) \quad (29)$$

Let us define  $e = J_{app} - J$ . From (28) and (29), we conclude the following:

$$\begin{aligned} \dot{e}(t) &= \sum_{i \in [1, \dots, m]} J_{\mathbf{x}_i} \cdot [f(\mathbf{x}_i, \bar{\mathbf{u}}_i) - f(\mathbf{x}_i, \mathbf{u}_i^*)] \\ |\dot{e}| &\leq \sum_{i \in [1, \dots, m]} \|J_{\mathbf{x}_i}\|_2 \cdot \|f(\mathbf{x}_i, \bar{\mathbf{u}}_i) - f(\mathbf{x}_i, \mathbf{u}_i^*)\|_2 \\ &\leq K \sum_{i \in [1, \dots, m]} \|J_{\mathbf{x}_i}\|_2 \cdot \|\bar{\mathbf{u}}_i - \mathbf{u}_i^*\|_2 \\ &= K \sum_{i \in [1, \dots, m]} \|J_{\mathbf{x}_i}\|_2 \cdot \left\| \frac{\int_{\mathcal{M}_{N_i^i}} (\mathbf{u}_i^*(\mathbf{y}) - \mathbf{u}_i^*(\mathbf{x})) d\mathbf{y}}{\int_{\mathcal{M}_{N_i^i}} \mathbf{1}} \right\| \end{aligned}$$

Let  $V(\mathbf{x}) = \int_{\mathcal{M}_{N_i^i}} \mathbf{1}$ .

$$= K \sum_{i \in [1, \dots, m]} \frac{\|J_{\mathbf{x}_i}\|_2}{V(\mathbf{x})} \cdot \left\| \int_{\mathcal{M}_{N_i^i}} (\mathbf{u}_i^*(\mathbf{y}) - \mathbf{u}_i^*(\mathbf{x})) d\mathbf{y} \right\|$$

Therefore, using the third assumption we can obtain the following bound:

$$|\dot{e}| \leq K \sum_{i \in [1, \dots, m]} \frac{\|J_{\mathbf{x}_i}\|_2}{V(\mathbf{x})} \int_{\mathcal{M}_{N_i^i}} \|\mathbf{u}_i^*(x) - \mathbf{u}_i^*(y)\|_2 d\mathbf{y}$$

From the second assumption on bounds on the control law, we can conclude that  $\|\mathbf{u}_i^*(\mathbf{x}) - \mathbf{u}_i^*(\mathbf{y})\|_2 \leq \beta$ . Therefore, the above expression is bounded by the following:

$$|\dot{e}| \leq K\beta \sum_{i \in [1, \dots, m]} \|J_{\mathbf{x}_i}\|_2 \quad (30)$$

From the assumptions at the beginning of this section, we obtain the following bound on the error rate:

$$|\dot{e}| \leq m\alpha\beta K = \delta \quad (31)$$

The optimal control laws for the agents maximize the Hamiltonian, which is  $(1 + \dot{J})$  in this game. Therefore, the following always holds

$$\dot{J}_{app} \leq \dot{J} \implies \dot{e} \leq 0 \quad (32)$$

From the definition of  $\dot{e}$ , we obtain the following relation:

$$\dot{J}_{app}(t) \geq \dot{J}(t) - \delta$$

Integrating the above equation on both sides from  $t = 0$  to  $t = \mathcal{T}(\mathbf{x})$  we obtain the following:

$$\begin{aligned} \int_0^{\mathcal{T}} \dot{J}_{app} dt &\geq \int_0^{\mathcal{T}} \dot{J} dt - \int_0^{\mathcal{T}} \delta dt \\ J_{app}(\mathcal{T}(\mathbf{x}_0)) - \mathcal{T}(\mathbf{x}_0) &\geq J(\mathcal{T}(\mathbf{x}_0)) - J(\mathbf{x}_0) - \delta \mathcal{T}(\mathbf{x}_0) \end{aligned}$$

$J_{app}(\mathcal{T}(\mathbf{x}_0)) = 0$ , since the network is disconnected at termination.  $J(\mathcal{T}(\mathbf{x}_0)) \geq 0$ , since the termination time of the original game is greater than  $\mathcal{T}(\mathbf{x}_0)$ . Therefore, we obtain the following bound for  $\mathcal{T}(\mathbf{x}_0)$ :

$$\mathcal{T}(\mathbf{x}_0) \leq \frac{J(\mathbf{x}_0)}{(1 - \delta)} \quad (33)$$

From the above expression, we get an upperbound for  $\mathcal{T}(\mathbf{x}_0)$ . The lower bound is trivially obtained from the definition of  $\mathcal{T}(\mathbf{x}_0)$ .  $\square$

In the next section, we address a special case in which the dynamics of each agent is linear, and includes a process noise.

**6. Estimator design techniques.** In this section, we underscore the difficulty associated with the formulation of a general multi-agent networked control system with process noise which is under attack. An important issue that arises in the case of control with process noise under noisy observation is that of certainty equivalence [57, 55, 2, 3, 6]. Even though certainty equivalence is a well-known property of the optimal controller in the linear-quadratic-Gaussian (LQG) problem, it has been shown that this does not readily carry over to similarly structured differential or dynamic games [2]. Even in zero-sum games with identical (noisy) measurements for the two players, only a restricted version of certainty equivalence holds [55, 3]. No general theory exists that would be applicable to the type of problems considered in this paper. Moreover, earlier studies on decentralized control systems have shown that only under specific assumptions on the state transition function, control law and noise processes affecting the system, a closed-form solution is achievable. Since obtaining optimum the solution is a formidable task, we resort to an approximation scheme, which is based on designing estimators for the agents that can be implemented during the actual play of the game. In addition to the assumptions made in the problem considered in the previous section, we make the following assumptions in this section :

- Each agent as well as the jammer knows the initial state of all the agents and the jammer.
- We assume that each agent and the jammer has a linear control law (this is possible, if the search for optimal control law is restricted to linear control laws for all agents and the jammer while computing the value function for the game).
- We assume that a process noise is acting on each agent and the jammer during the course of the game.

Under these assumption, we obtain the dynamics of the error in the estimate of each agent at each time instant. This problem is considerably more difficult than the problems considered in the previous section, since we do not know a priori if certainty equivalence holds in this case.

**6.1. Discrete-time system.** We slightly deviate from the notations used in the previous section. Consider  $m$  agents and a jammer, each governed by the following discrete-time linear equation

$$\begin{aligned} x^i(t+1) &= A_i x^i(t) + B_i u^i(t) + w^i(t) \\ \text{for } i &= 1, 2, \dots, m, m+1, t = 0, 1, 2, \dots, N. \end{aligned} \quad (34)$$

where,  $x^i(t) \in \mathbb{R}^n$  is the state,  $u^i(t) \in \mathbb{R}^p$  is the control,  $w^i(t) \in \mathbb{R}^n$  is the zero-mean process noise with bounded support for the  $i^{\text{th}}$  agent. The systems matrices for  $i^{\text{th}}$  agent are  $A_i \in \mathbb{R}^{n \times n}$  and  $B_i \in \mathbb{R}^{n \times p}$ . Each agent is assumed to observe its state perfectly. We assume that each agent has a linear control law  $u^i(t) = K_i \mathbf{x}(t)$  where  $K_i \in \mathbb{R}^{p \times n(m+1)}$  is the gain and  $\mathbf{x}(t)$  is a column vector comprised of states of all agents stacked together, i.e.,  $\mathbf{x}(t) = [(x^1(t))^T, \dots, (x^{m+1}(t))^T]^T$ . The jammer, assumed to be the  $m+1^{\text{th}}$  agent, chooses control actions to disconnect the network graph that leads to an intermittent state information available to the agents about the states of the other agents.

Recall that  $I(t)$  is the communication graph of the agents. Let us now construct a communication matrix  $\mathcal{C}(I(t)) := [\mathcal{C}_{ij}(I(t))]$ ,  $i, j = 1, 2, \dots, (m+1)^2$  as follows

$$\begin{aligned} \mathcal{C}_{ii}(I(t)) &= \begin{cases} 0_{n \times n} & \text{if } \left( \left\lfloor \frac{i-1}{m+1} \right\rfloor + 1, \text{mod}(i, m+1) \right) \in E(t) \\ I_{n \times n} & \text{otherwise.} \end{cases} \\ \mathcal{C}_{ij}(I(t)) &= 0_{n \times n}, \end{aligned}$$

where  $I_{n \times n}$  is an identity matrix of dimension  $n \times n$  and  $0_{n \times n}$  is a zero matrix of dimension  $n \times n$ . One can notice that the entries in this matrix have a strong coupling with the spatial arrangement of the agents and their distance with the jammer.

Let  $\tilde{\mathbf{x}}_i(t) \in \mathbb{R}^{n(m+1)}$  denote the estimated state of all agents and  $\tilde{\mathbf{u}}_i(t) \in \mathbb{R}^{p(m+1)}$  denote the estimated control of all agents based on the estimate of the state  $\tilde{\mathbf{x}}_i(t)$  by agent  $i$ . It should be noted that at each point in time, agent  $i$  has information from his neighbors  $N_i^j(t)$ , and its estimate  $\tilde{\mathbf{x}}_i(t)$  contains the exact information about his neighbors and himself. Let us denote the error in the estimate  $\tilde{\mathbf{x}}_i(t)$  of each agent from the actual state  $\mathbf{x}(t)$  by  $\mathbf{e}_i(t)$ , i.e.

$$\mathbf{e}_i(t) = \mathbf{x}(t) - \tilde{\mathbf{x}}_i(t). \quad (35)$$

The error values  $\mathbf{e}_i(t)$  change during the course of the game due to the disturbances on some agents and/or non-optimal behavior of some agents, as discussed in the formulation. By stacking each  $\mathbf{e}_i(t)$ , we get  $\mathcal{E}(t) := [\mathbf{e}_1^T(t), \dots, \mathbf{e}_{m+1}^T(t)]^T \in \mathbb{R}^{n(m+1)^2 \times 1}$ . We have the following lemma about the dynamics of the error  $\mathcal{E}(t)$ . Before the lemma, we introduce some notations that are used in the proof of the lemma.

**6.1.1. Preliminary notation for Lemma 6.1.** Let  $\mathbf{1} \in \mathbb{R}^{m+1}$ ,  $\mathbf{1} := [1, 1, \dots, 1]^T$  and  $\mathbf{e} \otimes \mathbf{1} := [\mathbf{e}^T, \dots, \mathbf{e}^T]^T$  be the usual Kronecker product of matrices. Let  $\mathbf{w}(t) := [(w^1(t))^T, \dots, (w^{m+1}(t))^T]^T$ . Let us define the following matrices:

- $\mathbf{A} := \text{diag}[A_1, A_2, \dots, A_{m+1}] \in \mathbb{R}^{n(m+1) \times n(m+1)}$
- $\mathbf{B} = \text{diag}[B_1, B_2, \dots, B_{m+1}] \in \mathbb{R}^{n(m+1) \times p(m+1)}$
- $\mathbf{K} = \text{diag}[K_1, K_2, \dots, K_{m+1}] \in \mathbb{R}^{p(m+1) \times n(m+1)^2}$

Also, define  $\mathcal{A} \in \mathbb{R}^{n(m+1)^2 \times n(m+1)^2}$  such that  $\mathcal{A} = [\mathcal{A}_{ij}]$  for  $i, j \in \{1, 2, \dots, m+1\}$ , and  $\mathcal{B} \in \mathbb{R}^{n(m+1) \times n(m+1)}$  as

$$\mathcal{A}_{ii} = (\mathbf{A} + \mathcal{B}) - \begin{pmatrix} 0_{n(i-1) \times n(m+1)} \\ B_i K_i \\ 0_{n(m+1-i) \times n(m+1)} \end{pmatrix},$$

$$\mathcal{A}_{ij} = \begin{pmatrix} 0_{n(j-1) \times n(m+1)} \\ -B_j K_j \\ 0_{n(m+1-j) \times n(m+1)} \end{pmatrix}, \quad \mathcal{B} = \begin{pmatrix} B_1 K_1 \\ B_2 K_2 \\ \vdots \\ B_{m+1} K_{m+1} \end{pmatrix}.$$

**Lemma 6.1.** *The vector  $\mathcal{E}(t)$  of errors in the estimates of all agents grows as*

$$\mathcal{E}(t+1) = (\mathcal{C}(I(t+1))\mathcal{A})\mathcal{E}(t) + \mathbf{w}(t) \otimes \mathbf{1}, \quad \mathcal{E}(0) = 0. \quad (36)$$

*Proof.* Since each agent is running an estimator to construct its strategy, they are actually using a control, say  $\tilde{\mathbf{v}}(t)$ , which is different from their optimal strategy,  $u^*(t)$ , under perfect state information. The approximate control  $\tilde{\mathbf{v}}(t)$  is constructed by stacking the control policy of each agent, obtained using their approximate states from their respective estimators. The estimated control  $\tilde{\mathbf{u}}_i(t)$  is based on the state estimate  $\tilde{\mathbf{x}}_i(t)$  of the  $i^{\text{th}}$  agent.

$$\tilde{\mathbf{v}}(t) = \begin{pmatrix} K_1 \tilde{\mathbf{x}}_1(t) \\ K_2 \tilde{\mathbf{x}}_2(t) \\ \vdots \\ K_{m+1} \tilde{\mathbf{x}}_{m+1}(t) \end{pmatrix}, \quad \tilde{\mathbf{u}}_i(t) = \begin{pmatrix} K_1 \tilde{\mathbf{x}}_i(t) \\ K_2 \tilde{\mathbf{x}}_i(t) \\ \vdots \\ K_{m+1} \tilde{\mathbf{x}}_i(t) \end{pmatrix}.$$

The difference between  $\tilde{\mathbf{v}}(t)$  and  $\tilde{\mathbf{u}}_i(t)$  is

$$\begin{aligned} \tilde{\mathbf{v}}(t) - \tilde{\mathbf{u}}_i(t) &= \begin{pmatrix} K_1((\mathbf{x}(t) - \tilde{\mathbf{x}}_i(t)) - (\mathbf{x}(t) - \tilde{\mathbf{x}}_1(t))) \\ K_2((\mathbf{x}(t) - \tilde{\mathbf{x}}_i(t)) - (\mathbf{x}(t) - \tilde{\mathbf{x}}_2(t))) \\ \vdots \\ K_{m+1}((\mathbf{x}(t) - \tilde{\mathbf{x}}_i(t)) - (\mathbf{x}(t) - \tilde{\mathbf{x}}_{m+1}(t))) \end{pmatrix}, \\ &= \begin{pmatrix} K_1(\mathbf{e}_i(t) - \mathbf{e}_1(t)) \\ K_2(\mathbf{e}_i(t) - \mathbf{e}_2(t)) \\ \vdots \\ K_{m+1}(\mathbf{e}_i(t) - \mathbf{e}_{m+1}(t)) \end{pmatrix}. \end{aligned}$$

The state  $\mathbf{x}(t)$  and the estimator  $\tilde{\mathbf{x}}_i(t)$  for agent  $i$  evolve according to

$$\begin{aligned} \mathbf{x}(t+1) &= \mathbf{A}\mathbf{x}(t) + \mathbf{B}\tilde{\mathbf{v}}(t) + \mathbf{w}(t) \\ \tilde{\mathbf{x}}_i(t+1) &= \mathbf{A}\tilde{\mathbf{x}}_i(t) + \mathbf{B}\tilde{\mathbf{u}}_i(t), \quad i = 1, 2, \dots, m+1. \end{aligned}$$

Now, we study the growth of error  $\mathbf{e}_i(t)$ . The equation for error dynamics is given by

$$\begin{aligned} \mathbf{e}_i(t+1) &= \mathbf{A}\mathbf{e}_i(t) + \mathbf{B}(\tilde{\mathbf{v}}(t) - \tilde{\mathbf{u}}_i(t)) + \mathbf{w}(t), \\ &= (\mathbf{A} + \mathcal{B})\mathbf{e}_i(t) - \mathbf{B}\mathcal{K}\mathcal{E}(t) + \mathbf{w}(t). \end{aligned}$$

Let us now consider the matrix of all errors  $\mathcal{E}(t)$ . Since agent  $i$  will receive the state information from its neighbors in the connectivity graph  $I(t+1)$  at time  $t+1$ ,

some entries in its error vector  $\mathbf{e}_i(t+1)$  will be zero. The dynamics of errors can be combined into one equation of the form

$$\mathcal{E}(t+1) = (\mathcal{C}(I(t+1))\mathcal{A})\mathcal{E}(t) + \mathbf{w}(t) \otimes \mathbf{1}.$$

The initial condition for the error dynamics is  $\mathcal{E}(0) = 0$ , since the state information of all the agents and the jammer are available to each other at the beginning of the game.  $\square$

The error in the estimate of the state  $\mathbf{e}_i(t)$  depends on the error in the estimate of the other agents. Therefore, an agent cannot make any judgment about the accuracy of his own estimate  $\hat{\mathbf{x}}_i(t)$ . However, stability of error can be inferred if the gradient of value function  $J$  is available and initial state is known. If the value function is obtained numerically, then the stability of the error can be established using numerical tools.

The error dynamics given in equation (36) are driven by i.i.d. noise. Because of the presence of noise, asymptotic convergence of error to zero is not possible. In order to ensure bounded error throughout the horizon, the error dynamics must be stable. For discrete time linear systems, this is equivalent to the spectral radius  $\mathcal{A}$  being less than 1. However, the dynamics here is that of a switched system for which the stability conditions are different.

From the Lyapunov stability criterion for switched systems [42], we know that the error values remain bounded if we can find a positive definite matrix  $P$ , such that the following holds true

$$(\mathcal{C}(I(t+1))\mathcal{A})^T P + P(\mathcal{C}(I(t+1))\mathcal{A}) \prec -\alpha I_{n(m+1)^2 \times n(m+1)^2}, \quad (37)$$

for some positive  $\alpha$  at all time  $t$ . This, however, is not applicable to the problem at hand. Since many agents remain connected in the system, some of the diagonal entries in  $\mathcal{C}(I(t+1))$  remain 0, which in turn implies that  $(\mathcal{C}(I(t+1))\mathcal{A})^T P + P(\mathcal{C}(I(t+1))\mathcal{A})$  leaves some rows with zeros as all its elements. Hence, the left hand side cannot be negative definite at any time  $t$ .

We can notice that the control strategy of the agents of the game play dual role in the system. One, which is obvious, is that they are trying to optimize certain objective functional and achieve some goal (which in this case is to maintain connectivity). The other, which is hidden is that they are also acting on the error dynamics of the system. The control policy can be carefully chosen to achieve optimal trade-off between these two seemingly unrelated (maybe even conflicting) goals.

**7. Conclusion.** In this paper, we considered the problem of jamming in a communication network within a team of autonomous mobile agents. First, we considered a differential game-theoretic approach to compute optimal strategies for a team of UAVs trying to evade a jamming attack initiated by an aerial jammer in their vicinity. We formulated the problem as a zero-sum pursuit-evasion game, where the cost function is the termination time of the game. We used *Isaacs'* approach to obtain necessary conditions to arrive at the equations governing the saddle-point strategies of the players. We illustrated the results through simulations. Next, we analyzed the problem of jamming from the perspective of maintaining connectivity in a network of mobile agents in the presence of an adversary. This is a variation of the standard connectivity maintenance problem in which the main issue is to deal with the limitations in communications and sensing model of each agent. In

our work, the limitations in communication are due to the presence of a jammer in the vicinity of the mobile agents. We computed evasion strategies for the team of vehicles based on the connectivity of the resultant *state-dependent graph*. We presented some simulations to validate the proposed control scheme. Finally, we addressed the problem of jamming for the scenario in which each agent computes its control strategy based on limited information available about its neighbors in the network. Under this decentralized information structure, we proposed two approximation schemes for the agents and studied the performance of the entire team for each scheme.

Among the future works are to extend the locally optimal trajectories presented in this paper into the entire phase space so as to obtain the globally optimal trajectories. This is an extremely hard problem due to the curse of dimensionality associated with the HJI equations. Moreover, it would require the construction of various types of singular surfaces [44, 5, 40]. Other interesting directions are to incorporate communication delays within the agents, and address the problem of inter-agent collision avoidance among the autonomous agents.

#### REFERENCES

- [1] V. I. Arnold, “Geometric Method in the Theory of Ordinary Differential Equations,” Springer-Verlag, New York, 1983.
- [2] T. Başar, *Two-criteria LQG decision problems with one-step delay observation sharing pattern*, Information and Control, **38** (1978), 21–50.
- [3] T. Başar, *On the saddle-point solution of a class of stochastic differential games*, Journal of Optimization Theory and Applications, **33** (1981), 539–556.
- [4] T. Başar and S. Li, *Distributed computation of Nash equilibria in linear-quadratic stochastic differential games*, SIAM Journal on Control and Optimization, **27** (1989), 563–578.
- [5] T. Başar and G. J. Olsder, “Dynamic Noncooperative Game Theory,” 2nd Ed., SIAM Series in Classics in Applied Mathematics, Philadelphia, 1999.
- [6] Y. Bar-Shalom and E. Tse, *Dual effect, certainty equivalence, and separation in stochastic control*, IEEE Transactions on Automatic Control, **19** (1974), 494–500.
- [7] S. Bhattacharya, A. Gupta and T. Başar, *Decentralized opportunistic navigation strategies for multi-agent systems in the presence of an adversary*, in “IFAC World Congress,” Milan, Italy, August, (2011), 11809–11814.
- [8] S. Bhattacharya and T. Başar, *Differential game-theoretic approach for spatial jamming attack in a UAV communication network*, in “14th International Symposium on Dynamic Games and Applications,” Banff, CA, June, 2010.
- [9] S. Bhattacharya and T. Başar, *Game-theoretic analysis of an aerial jamming attack on a UAV communication network*, in “American Control Conference,” Baltimore, Maryland, June, (2010), 818–823.
- [10] S. Bhattacharya and T. Başar, *Graph-theoretic approach to connectivity maintenance in mobile networks in the presence of a jammer*, in “IEEE Conference on Decision and Control,” Atlanta, GA, December, (2010), 3560–3565.
- [11] S. Bhattacharya and T. Başar, *Optimal strategies to evade jamming in heterogeneous mobile networks*, in “Workshop on search and pursuit-evasion,” Anchorage, Alaska, 2010.
- [12] S. Bhattacharya and T. Başar, *Differential game-theoretic approach to a spatial jamming problem*, Annals of Dynamic Games, 2011, to appear.
- [13] S. Bhattacharya and T. Başar, *Spatial approaches to broadband jamming in heterogeneous mobile networks: A game-theoretic approach*, Autonomous Robots, **31** (2011), 367–381.
- [14] N. Biggs. “Algebraic Graph Theory,” Cambridge University Press, Cambridge, U.K., 1993.
- [15] A. Blaquière, F. Gerard and G. Leitmann. “Quantitative and Qualitative Games,” Academic Press, New York, NY, 1969.

- [16] J. V. Breakwell and P. Hagedorn, *Further properties of non-zero sum differential games*, Journal of Optimization Theory and Applications, **3** (1969), 207–219.
- [17] J. V. Breakwell and P. Hagedorn, *Point capture of two evaders in succession*, Journal of Optimization Theory and Applications, **27** (1979), 89–97.
- [18] H. Cao, E. Ertin, V. Kulathumani, M. Sridharan and A. Arora, *Differential games in large-scale sensor-actuator networks*, in “The Fifth International Conference on Information Processing in Sensor Networks (IPSN),” (2006), 77–84.
- [19] H. Choset, K. M. Lynch, S. Hutchinson, G. Kantor, W. Burgard, L. Kavraki and S. Thrun, “Principles of Robot Motion: Theory, Algorithms, and Implementations,” The MIT Press, Cambridge, MA, 2005.
- [20] R. Cogill and S. Lall, *An approximation algorithm for the discrete team decision problem*, SIAM Journal on Control and Optimization, **45** (2007), 1359–1368.
- [21] M. C. DeGennaro and A. Jadbabaie, *Decentralized control of connectivity for multiagent systems*, in “IEEE Conference on Decision and Control,” San Diego, CA, December, (2006), 3628–3633.
- [22] J. A. Fax and R. M. Murray, *Information flow and cooperative control of vehicle formations*, IEEE Transactions on Automatic Control, **9** (2004), 1465–1474.
- [23] F. Bullo, G. Notarstefano, K. Savla and A. Jadbabaie, *Maintaining limited-range connectivity among second order agents*, in “American Control Conference,” Minneapolis, June 2006, 2124–2129.
- [24] S. Gorman, Y. J. Dreazen and A. Cole, *Insurgents hack U.S. drones*, December 2009. Available from: <http://online.wsj.com/article/SB126102247889095011.html>.
- [25] A. Gupta, S. Bhattacharya and T. Başar, *Decentralized control of multi agent system with adversarial switching topology*, in “Infotech and Aerospace Conference,” St. Louis, Missouri, March, 2011.
- [26] P. Hagedorn and J. V. Breakwell, *A differential game of approach with two pursuers and one evader*, Journal of Optimization Theory and Applications, **18** (1976), 15–29.
- [27] R. Isaacs, “Differential Games,” Wiley, New York, 1965.
- [28] A. Jadbabaie, E. Stump and V. Kumar, *Connectivity management in mobile robot teams*, in “IEEE International conference on Robotics and Automation,” May 2008, 1525–1530.
- [29] A. Jadbabaie, H. Tanner and G. Pappas, *Flocking in fixed and switching networks*, IEEE Transactions on Automatic Control, **5** (2007), 863–868.
- [30] M. Ji and M. Egerstedt, *Connectedness preserving distributed coordination control among dynamic graphs*, in “American Control Conference,” Portland, OR, June, (2005), 93–98.
- [31] M. Ji and M. Egerstedt, *Distributed formation control while preserving connectedness*, in “IEEE Conference on Decision and Control,” San Diego, CA, December, (2006), 5962–5967.
- [32] V. Kumar, N. Michael, M. M. Zavlanos and G. J. Pappas, *Maintaining connectivity in mobile robot networks*, in “Eleventh International Symposium on Experimental Robotics,” Athens, Greece, July, 2008.
- [33] G. Leitmann, *An optimum pursuit problem*, Journal of the Franklin Institute, **263** (1957), 499–503.
- [34] G. Leitmann, “An Introduction to Optimal Control,” McGraw-Hill, NY, 1966.
- [35] G. Leitmann, *A differential game of pursuit and evasion*, International Journal of Non Linear Mechanics, **4** (1969), 1–6.
- [36] G. Leitmann, “Cooperative and Non-Cooperative Many Player Differential Games,” Springer Verlag, Vienna, 1974.
- [37] G. Leitmann, *Guaranteed avoidance feedback control*, IEEE Transactions on Automatic Control, **25** (1980), 850–851.
- [38] G. Leitmann and S. Gutman, *Optimal strategies in the neighborhood of a collision course*, AIAA Journal, **14** (1976), 1210–1212.
- [39] A. Y. Levchenkov and A. G. Pashkov, *Differential game of optimal approach of two inertial pursuers to a noninertial evader*, Journal of Optimization Theory and Applications, **65** (1990), 501–518.

- [40] J. Lewin, “Differential Games: Theory and Methods for Solving Game Problems with Singular Surfaces,” Springer-Verlag, London, 1994.
- [41] S. Li and T. Başar, *Distributed algorithms for the computation of noncooperative equilibria*, Automatica, **23** (1987), 523–533.
- [42] D. Liberzon, “Switching in Systems and Control,” Birkhauser, 2003.
- [43] D. McCullagh, *Predator drones hacked in Iraq operations*, December 2009, Available from: [http://news.cnet.com/8301-1009\\_3-10417247-83.html](http://news.cnet.com/8301-1009_3-10417247-83.html).
- [44] A. A. Melikyan, “Generalized Characteristics of First Order PDEs: Applications in Optimal Control and Differential Games,” Applications of Mathematics, 2000.
- [45] M. Mesbahi and M. Egerstedt, “Graph Theoretic Methods in Multiagent Networks,” Princeton University Press, New Jersey, 2010.
- [46] Mehran Mesbahi, *On state-dependent dynamic graphs and their controllability properties*, IEEE Transactions on Automatic Control, **50** (2005), 387–392.
- [47] I. M. Mitchell and C. J. Tomlin, *Overapproximating reachable sets by hamilton-jacobi projections*, Journal of Scientific Computing, **19** (2003), 323–346.
- [48] G. Noubir and G. Lin, *Low power denial of service attacks in data wireless lans and countermeasures*, in “ACM Mobihoc,” 2003.
- [49] R. Olfati-Saber and R. M. Murray, *Consensus problems in networks of agents with switching topology and time delay*, IEEE Transactions on Automatic Control, **49** (2004), 1520–1533.
- [50] P. Papadimitratos and Z. J. Haas, *Secure routing for mobile ad hoc networks*, in “SCS Communication Networks and Distributed Systems Modeling and Simulation Conference,” January, (2002), 27–31.
- [51] C. H. Papadimitriou and J. N. Tsitsiklis, *Intractable problems in control theory*, SIAM Journal on Control and Optimization, **24** (1986), 639–654.
- [52] A. G. Pashkov and S. D. Terekhov, *A differential game of approach with two pursuers and one evader*, Journal of Optimization Theory and Applications, **55** (1987), 303–311.
- [53] R. A. Poisel, “Modern Communication Jamming Principles and Techniques,” Artech, Massachusetts, 2004.
- [54] John J. Proakis and Masoud Salehi, “Digital Communications,” McGraw-Hill, 2007.
- [55] I. Rhodes and D. Luenberger, *Differential games with imperfect state information*, IEEE Transactions on Automatic Control, **14** (1969), 29–38.
- [56] Sriram Shankaran, Dušan Stipanović and Claire Tomlin, *Collision avoidance strategies for a three player game*, in “International Symposium of Dynamic Games and Applications,” Wrocław, Poland, July 2008.
- [57] J. Shinar and T. Vladimir, *What happens when certainty equivalence is not valid? Is there an optimal estimator for terminal guidance?*, Annual Reviews in Control, **27** (2003), 119–130.
- [58] D. P. Spanos and R. M. Murray, *Robust connectivity of networked vehicles*, in “IEEE Conference on Decision and Control,” Bahamas, December, (2004), 2893–2898.
- [59] M. Spivak, “Calculus on Manifolds: A modern approach to Classical Theorems of Advanced Calculus,” Perseus Books Publishing, 1965.
- [60] D. M. Stipanović, S. Shankaran and C. Tomlin, *Strategies for agents in multi-player pursuit-evasion games*, in “Eleventh International Symposium on Dynamic Games and Applications,” 2008.
- [61] D. M. Stipanović, I. Hwang and C. J. Tomlin, *Computation of an over-approximation of the backward reachable set using subsystem level set functions*, Dynamics of Continuous, Discrete and Impulsive systems, Series A: Mathematical Analysis, **11** (2004), 399–411.
- [62] D. M. Stipanović, A. A. Melikyan and N. V. Hovakimyan, *Some sufficient conditions for multi-player pursuit evasion games with continuous and discrete observations*, in “Annals of the International Society of Dynamic Games,” (2009), 133–145.
- [63] J. Tobias and N. Seddon, *Signal jamming mediates sexual conflict in a duetting bird*, Current Biology, **19** (2009), 577–582.
- [64] J. Tsitsiklis and M. Athans, *On the complexity of decentralized decision making and detection problems*, IEEE Transactions on Automatic Control, **30** (1985), 440–446.

- [65] E. M. Vaisbord and V. I. Zhukovskiy, “Introduction to Multi-player Differential Games and their Applications,” Gordon and Breach, New York, 1988.
- [66] M. M. Zavlanos and G. J. Pappas, *Controlling connectivity of dynamic networks*, in “44th IEEE Conference on Decision and Control,” Seville, Spain, December, (2005), 6388–6393.
- [67] M. M. Zavlanos and G. J. Pappas, *Distributed connectivity control of mobile networks*, in “46th IEEE Conference on Decision and Control,” New Orleans, LA, December, (2007), 3591–3596.
- [68] M. M. Zavlanos and G. J. Pappas, *Potential fields for maintaining connectivity of mobile networks*, IEEE Transactions on Robotics, **23** (2007), 812–816.
- [69] M. M. Zavlanos and G. J. Pappas, *Distributed connectivity control of mobile networks*, IEEE Transactions on Robotics, **24** (2008), 1416–1428.
- [70] V. I. Zhukovskiy and M. E. Salukvadze, “The Vector Valued Maxmin,” Academic Press, San Diego, 1994.

Received December 2011; 1<sup>st</sup> revision October 2012; 2<sup>nd</sup> revision November 2012.

*E-mail address:* [sbhattac@iastate.edu](mailto:sbhattac@iastate.edu)

*E-mail address:* [gupta54@illinois.edu](mailto:gupta54@illinois.edu)

*E-mail address:* [basar1@illinois.edu](mailto:basar1@illinois.edu)