

ESTCP Cost and Performance Report

(CU-0015)



In Situ Remediation of MTBE-Contaminated Aquifers Using Propane Biosparging

September 2003



ENVIRONMENTAL SECURITY
TECHNOLOGY CERTIFICATION PROGRAM

U.S. Department of Defense

Report Documentation Page

Form Approved
OMB No. 0704-0188

Public reporting burden for the collection of information is estimated to average 1 hour per response, including the time for reviewing instructions, searching existing data sources, gathering and maintaining the data needed, and completing and reviewing the collection of information. Send comments regarding this burden estimate or any other aspect of this collection of information, including suggestions for reducing this burden, to Washington Headquarters Services, Directorate for Information Operations and Reports, 1215 Jefferson Davis Highway, Suite 1204, Arlington VA 22202-4302. Respondents should be aware that notwithstanding any other provision of law, no person shall be subject to a penalty for failing to comply with a collection of information if it does not display a currently valid OMB control number.

1. REPORT DATE SEP 2003		2. REPORT TYPE		3. DATES COVERED 00-00-2003 to 00-00-2003	
4. TITLE AND SUBTITLE In Situ Remediation of MTBE-Contaminated Aquifers Using Propane Biosparging				5a. CONTRACT NUMBER	
				5b. GRANT NUMBER	
				5c. PROGRAM ELEMENT NUMBER	
6. AUTHOR(S)				5d. PROJECT NUMBER	
				5e. TASK NUMBER	
				5f. WORK UNIT NUMBER	
7. PERFORMING ORGANIZATION NAME(S) AND ADDRESS(ES) Environmental Security Technology Certification Program (ESTCP), 4800 Mark Center Drive, Suite 17D08, Alexandria, VA, 22350-3605				8. PERFORMING ORGANIZATION REPORT NUMBER	
9. SPONSORING/MONITORING AGENCY NAME(S) AND ADDRESS(ES)				10. SPONSOR/MONITOR'S ACRONYM(S)	
				11. SPONSOR/MONITOR'S REPORT NUMBER(S)	
12. DISTRIBUTION/AVAILABILITY STATEMENT Approved for public release; distribution unlimited					
13. SUPPLEMENTARY NOTES					
14. ABSTRACT					
15. SUBJECT TERMS					
16. SECURITY CLASSIFICATION OF:			17. LIMITATION OF ABSTRACT	18. NUMBER OF PAGES	19a. NAME OF RESPONSIBLE PERSON
a. REPORT unclassified	b. ABSTRACT unclassified	c. THIS PAGE unclassified			

COST & PERFORMANCE REPORT

ESTCP Project: CU-0015

TABLE OF CONTENTS

		Page
1.0	EXECUTIVE SUMMARY	1
1.1	BACKGROUND	1
1.2	OBJECTIVES OF THE DEMONSTRATION	1
1.3	REGULATORY DRIVERS	2
1.4	DEMONSTRATION RESULTS	2
1.5	STAKEHOLDER/END USE ISSUES	4
2.0	TECHNOLOGY DESCRIPTION	5
2.1	TECHNOLOGY DEVELOPMENT AND APPLICATION	5
2.2	PROCESS DESCRIPTION	5
2.3	ADVANTAGES AND LIMITATIONS OF THE TECHNOLOGY	12
3.0	DEMONSTRATION DESIGN	15
3.1	PERFORMANCE OBJECTIVES	15
3.2	SELECTION OF TEST SITE	15
3.3	TEST SITE HISTORY AND CHARACTERISTICS	16
3.4	PHYSICAL SET-UP AND OPERATION	19
	3.4.1 Microcosm Studies	19
	3.4.2 Site Preparation	19
	3.4.3 Test and Control Plot Description	20
	3.4.4 Installation and Operation	21
3.5	SAMPLING, MONITORING, AND ANALYTICAL PROCEDURES	23
4.0	PERFORMANCE ASSESSMENT	27
4.1	PERFORMANCE DATA AND DATA ASSESSMENT	27
4.2	CONCLUSIONS	28
5.0	COST ASSESSMENT	31
5.1	COST REPORTING	31
	5.1.1 Reported Demonstration	31
	5.1.2 Subsequent Demonstration	32
	5.1.3 Full-Scale	33
	5.1.3.1 Cost Estimate for Propane Biosparging Biobarrier	33
	5.1.3.2 Cost Estimate for Propane Biosparging (Simultaneous Treatment of the Entire Site)	36
	5.1.3.3 Cost Estimate for Pump and Treat	38
5.2	COST ANALYSIS	40
	5.2.1 Propane Biosparging	40
	5.2.2 Pump and Treat	42

TABLE OF CONTENTS (continued)

	Page
5.3	COST COMPARISON OF TECHNOLOGIES 43
5.3.1	Effect of Matrix Characteristics 43
5.3.2	Issues that Affect Cost Savings 44
6.0	IMPLEMENTATION ISSUES 45
6.1	COST OBSERVATIONS 45
6.2	PERFORMANCE OBSERVATIONS 45
6.3	SCALE-UP 46
6.4	OTHER SIGNIFICANT OBSERVATIONS 46
6.5	LESSONS LEARNED 47
7.0	REFERENCES 49
APPENDIX A	POINTS OF CONTACT A-1

LIST OF FIGURES

	Page
Figure 1.	Conceptual Model of In Situ Propane Biosparging 6
Figure 2.	Demonstration Area Layout 8
Figure 3.	Demonstration Area Layout for the Test Plot 9
Figure 4.	Demonstration Area Layout for the Control Plot 10
Figure 5.	Propane Biosparging System Piping and Instrumentation Diagram 11
Figure 6.	Port Hueneme Plume Map 17
Figure 7.	Location of Test Plot 18
Figure 8.	Well Construction Specifications 22

LIST OF TABLES

	Page
Table 1.	Summary of MTBE Concentrations ($\mu\text{g/l}$) in Control and Test Plots 3
Table 2.	Key Criteria for the Design and Operation of a Propane Biostimulation System 7
Table 3.	Analytical Methods 24
Table 4.	Actual Demonstration Costs 31
Table 5.	Costs for Demonstration-Scale Implementation 32
Table 6.	Cost Reporting for MTBE Remediation with Propane Biosparging (Biobarrier) 35
Table 7.	Cost Reporting for MTBE Remediation with Propane Biosparging (Entire Site) 37
Table 8.	Cost Reporting for MTBE Remediation with Pump and Treat 39
Table 9.	Sensitivity Analysis for MTBE Remediation with Propane Biosparging (Biobarrier or Entire Site) 42
Table 10.	Sensitivity Analysis for MTBE Remediation with Pump and Treat 43

LIST OF ABBREVIATIONS AND ACRONYMS

AS	Air Sparging
BIP	bacteria injection point
BOD	Biological Oxygen Demand
BTEX	benzene, toluene, ethylbenzene, and xylenes
CBC	Construction Battalion Center
CCL	Contaminant Candidate List
COD	Carbon Oxygen Demand
CPT	cone penetrometer
CWQCB	California Water Quality Control Board
DHS	Department of Environmental Health Services
ENV425	<i>Rhodococcus Ruber</i> Bacteria Strain
ESTCP	Environmental Security Technology Certification Program
FID	Flame Ionization Detector
GWC	gross weight control
GWT	gross weight test
HLC	Henry's Law Coefficient
ID	Inner Diameter
LEL	lower explosive limit
LNAPL	light non-aqueous phase liquid
LPGAC	liquid phase granular activated carbon
MCL	maximum contaminant level
MTBE	Methyl tert-butyl ether
NCBC	Naval Construction Battalion Center
NCF	Naval Construction Force
NETTS	National Environmental Technology Test Site
NEX	Naval Exchange
NFESC	Naval Facility Engineering Service Center
NPDES	National Pollutant Discharge Elimination System
NPV	Net Present Value
O&M	operation and maintenance
OIP	oxygen injection point

LIST OF ABBREVIATIONS AND ACRONYMS (continued)

OMB	Office of Management and Budget
ORP	oxidation-reduction potential
PF	pneumatic fracturing
PIP	propane injection point
PMO	propane monooxygenase
POB	propane oxidizing bacteria
PSIG	pounds per square inch gauge
QA/QC	Quality Assurance/Quality Control
ROI	radius of influence
SCFH	cubic feet per hour at standard conditions
SVE	soil vapor extraction
TBA	Tert-butyl Alcohol
TOC	Total Organic Carbon
UCD	University of California at Davis
UCMR	Unregulated Contaminant Monitoring Rule
U.S. EPA	U.S. Environmental Protection Agency
U.S. EPA SITE	U.S. Environmental Protection Agency Superfund Innovative Technology Evaluation
UVB	Unterduck-Verdampfer-Brunnen
VMP	vapor monitoring point
VOC	volatile organic compound

ACKNOWLEDGMENTS

We are grateful to the Environmental Security Technology Certification Program for providing funding and support for this project. The Base and NFESC personnel at Port Hueneme performed operation and maintenance activities during the demonstration, and provided assistance and support when needed during sampling events, sometimes on short notice. Their assistance is truly appreciated. They also were the primary contact with the California Water Quality Control Board, and included ENVIROGEN's demonstration activities and results in their monthly reports to the Board as required by the Monitoring and Reporting Program. These personnel include, among others, Ernie Lory, Dorothy Cannon, Kathy Greene, Thomas Strassburger, Dale Lorenzana, Gail Pringle, and Bill Major. We appreciate the collaboration and efforts of U.S. Environmental Protection Agency (U.S. EPA), including Ann Keeley and others, in carrying out their work as part of EPA's Technology Verification Program.

Technical material contained in this report has been approved for public release.

1.0 EXECUTIVE SUMMARY

1.1 BACKGROUND

Methyl *tert*-butyl ether (MTBE) has been used as a high-octane additive in mid and high-grade gasoline since 1979, and to replace lead and other gasoline additives such as benzene, toluene, ethylbenzene and xylenes (BTEX). The 1990 Clean Air Act Amendments required that in high pollution areas of the country, oxygenates be used in all grades of gasoline. MTBE was selected as the oxygenate of choice to meet the new standards. In 1992, more than 1.8 billion gallons of MTBE went into gasoline, and its use has increased each year since. In 1995, 17.62 billion pounds of MTBE was produced primarily for use in gasoline, and its production and use has continued to increase. The discharge of gasoline from leaky underground storage tanks into soils and groundwater has resulted in the contamination of these media with MTBE. Because MTBE is highly soluble in water (~43,000 mg/L), it is often found as plumes in groundwater near service stations, storage facilities, and filling terminals throughout the United States. More than 300,000 releases from leaking underground tanks have been reported to state regulatory agencies.

Historically, the most common treatment technology for groundwater contamination has been a pump and treat approach. Because of its high aqueous solubility, low Henry's Law Constant (low volatility from water), and poor adsorption to carbon, the usual *ex situ* treatment techniques designed for contaminants such as benzene and trichloroethylene have proven to be ineffective or expensive for removal of MTBE from groundwater. *In situ* approaches to groundwater remediation include air or nutrient supplementation to stimulate contaminant degradation (e.g., biosparging), addition of compounds such as zero-valent iron for chemical dechlorination, and addition of bacteria capable of contaminant destruction (bioaugmentation). For many contaminants, including most petroleum constituents (BTEX, alkanes, etc), subsurface aeration effectively promotes aerobic contaminant destruction by stimulating the natural microflora in the region to degrade the polluting compounds. However, the recalcitrance of MTBE relative to other gasoline components generally makes it resistant to *in situ* biostimulation approaches such as air sparging (AS) and/or nutrient-amendment. Thus, unlike many groundwater contaminants, a novel approach is often required for *in situ* remediation of MTBE in contaminated groundwater.

There are several potential advantages to using a biostimulation approach for degrading MTBE *in situ*. Biostimulation uncouples biodegradation of the contaminant from growth of the organisms. That is, the microbes can be supplied sufficient co-substrate (e.g., propane) to support growth, so they do not have to rely on the utilization of low levels of contaminants to maintain their survival. Also, the technology can be applied in a number of configurations depending on site characteristics and treatment needs. Furthermore, propane is widely available, transportable even to remote sites, already present at many gasoline stations, and relatively inexpensive. Thus, propane biosparging has the potential to be an attractive remediation option at a wide variety of MTBE-contaminated sites.

1.2 OBJECTIVES OF THE DEMONSTRATION

The objective of this Environmental Security Technology Certification Program (ESTCP)-funded project was to demonstrate application of propane biosparging (biostimulation) for *in situ* remediation of MTBE-contaminated aquifers. The primary objectives of this ESTCP-funded project

were (1) to demonstrate the safe application of propane biosparging (i.e., biostimulation) for in situ remediation of MTBE; and (2) evaluate the ability of propane biosparging to reduce MTBE concentrations in contaminated aquifers to below California Department of Health Services regulatory limit of 5 µg/L. To meet this, several secondary goals were identified and include: (1) performing microcosm testing to evaluate the ability of indigenous propane oxidizing bacteria and/or other microorganisms to degrade MTBE; (2) selecting and characterizing a field demonstration site; (3) using field characterization and microcosm study data to design, construct and operate a field demonstration system; (4) evaluating performance of the treatment system during a 10-month treatment period; and (5) evaluating the cost of applying the technology at full scale. The project compared MTBE biodegradation in a test plot that was amended with propane oxidizing bacteria and treated with oxygen and propane to a control plot that received only oxygen. The technology also was evaluated under the U.S. EPA Superfund Innovative Technology Evaluation (SITE) Program as part of the U.S. EPA's MTBE Treatment Technology Verification Program. The demonstration was conducted from May of 2001 to March of 2002.

1.3 REGULATORY DRIVERS

There is currently no federal drinking water standard for MTBE. However, the oxygenate has been added to both the Unregulated Contaminant Monitoring Rule (UCMR) and the Contaminant Candidate List (CCL) by the U.S. EPA based on provisions of the Safe Drinking Water Act. In December 1997, EPA issued a drinking water advisory that states concentrations of MTBE in the range of 20 to 40 µg/L of water or below will probably not cause unpleasant taste and odor for most people and stated that there is little likelihood that MTBE concentrations between 20 and 40 µg/L in drinking water would cause negative health effects (U.S. EPA, 2002).

The California Department of Environmental Health Services (DHS) has recently established a primary Maximum Contaminant Level (MCL) for MTBE of 13 µg/L to protect public health and a secondary MCL of 5 µg/L to prevent taste and odor problems in groundwater (California Department of Environmental Health Services, 2002). Several other states including Pennsylvania, New Jersey, and New York have followed California in reducing their groundwater standards for MTBE. The treatment objective in this demonstration was to reduce MTBE concentrations to below California's secondary MCL of 5 µg/L. This is the standard to which the demonstration data are compared.

Tert-butyl alcohol (TBA) is a fuel oxygenate, a common co-contaminant in MTBE-contaminated groundwater, and a product of MTBE degradation. Although TBA is a known toxin and a possible carcinogen, it is not currently an EPA priority groundwater pollutant. The recent introduction of drinking water standards for TBA in a number of states suggests that future regulation of TBA is likely (Bradley, et. al, 2002). The California DHS has established an Action Level for TBA in drinking water of 12 µg/L. TBA concentrations reached in this demonstration are compared to California's Action Level of 12 µg/L.

1.4 DEMONSTRATION RESULTS

A summary of the demonstration results is presented in Table 1 of this report. As expected, based on microcosm studies and previous demonstrations at the site, MTBE concentrations decreased in both the test and control plots during the demonstration. However, MTBE concentrations were reduced to less than 5 µg/L in only 3 of the 30 monitoring wells in the test plot and in none of the

wells in the control plot. Therefore, the primary treatment objective of reaching 5 µg/L MTBE in all test plot monitoring wells was not met.

Table 1. Summary of MTBE Concentrations (µg/l) in Control and Test Plots.

Test Plot	5/20/01 – 5/22/01		3/11/02 – 3/12/02		Percent Removal 5/01 through 3/02
	Average	Std. Dev.	Average	Std. Dev.	
Test Row 1 Shallow (Gross Weight Test [GWT] 2S-4S)	473	290	105	57	77.9
Test Row 2 Shallow (GWT 5S-7S)	513	376	64	48	87.5
Test Row 3 Shallow (GWT 8S-10S)	230	89	86	71	62.5
Test Row 4 Shallow (GWT 11S-13S)	180	89	40	33	77.6
Test Row 5 Shallow (GWT 14S-15S)	110	100	15	18	86.3
Test Row 1 Deep (GWT 2D-4D)	1,800	436	168	236	90.6
Test Row 2 Deep (GWT 5D-7D)	2,067	723	148	108	92.8
Test Row 3 Deep (GWT 8D-10D)	2,400	917	95	34	96.0
Test Row 4 Deep (GWT 11D-13D)	1,360	1,080	187	81	86.3
Test Row 5 Deep (GWT 14D-15D)	2,550	1,202	82	83	96.8
Control Row 1 Shallow (Gross Weight Control [GWC] 2S-4S)	1,187	1,150	256	303	86.4
Control Row 2 Shallow (GWC 5S-7S)	766	839	22	15	97.1
Control Row 3 Shallow (GWC 8S-10S)	610	285	27	36	95.6
Control Row 1 Deep (GWC 2D-4D)	4,667	814	502	617	89.2
Control Row 2 Deep (GWC 5D-7D)	4,633	777	558	732	87.9
Control Row 3 Deep (GWC 8D-10D)	5,333	1,380	527	670	90.1

Results of this study demonstrated that most of the active MTBE degradation that occurred in both plots appeared to occur near the oxygen injection points. This limit of degradation activity was likely caused by consumption of the oxygen added to the plots by both geochemical oxygen sinks and biological activity. Oxygen levels in the deep wells of the Test Plot typically were lower than those in the deep wells of the Control Plot, and in both plots dissolved oxygen concentrations were reduced to <5 µg/L in most of the down gradient wells. Because of the process monitoring and

technology validation procedures of both ENVIROGEN and the U.S. EPA, researchers elected not to increase gas flows into the site during this demonstration. To reach even lower MTBE levels, however, either additional rows of oxygen and propane injection points (PIPs) may be needed, or oxygen loading rates may need to be increased.

1.5 STAKEHOLDER/END USE ISSUES

In addition to the quality of groundwater entering the system and downgradient discharge requirements, some site characteristics and support requirements may be important when considering the propane biosparging technology. Because the system can be either transportable or permanently installed, the support requirements for these systems are likely to vary.

A primary site requirement is the availability of electricity. For the unit used during the demonstration, a 3-phase, 206V power was utilized. The system controls operated using conditioned power reduced to 24V AC power to the individual timers and solenoid valves, but other power sources can be used as needed by changing system components to meet the available power. Other utilities required include a small amount of water for cleaning equipment. A fence and/or shed may be employed to secure the system components, and signage should be utilized to warn of the potential explosion hazard. No smoking should be permitted anywhere on site. If the portable unit is used, the site must be accessible for an 8-foot by 10-foot trailer. The area containing the trailer should be paved or covered with compact soil or gravel to prevent the trailer from sinking into soft ground.

Propane biosparging technology uses commercially available, off-the-shelf components to establish bioreactive treatment zones. Equipment used in the performance and monitoring of the demonstration is available through standard suppliers. The equipment includes compressed gas cylinders to provide the source of propane, sometimes oxygen, and simple timer-actuated solenoid valves to control flow. Thus, system performance is dictated by the delivery of the gases into solution, and routine monitoring of flow and pressure measurements at the injection points, monitoring of oxygen and propane use, and changing spent gas cylinders is required. If oxygen is supplied with a blower or compressor, routine checks of the airflow rates and blower or compressor operation, and routine blower or compressor maintenance, is required.

2.0 TECHNOLOGY DESCRIPTION

2.1 TECHNOLOGY DEVELOPMENT AND APPLICATION

This technology has been developed by ENVIROGEN as the need for alternative treatment approaches for MTBE-contaminated groundwater has become apparent. ENVIROGEN has worked since the early 1990s to understand and isolate microorganisms capable of degrading of MTBE and TBA.

The propane biosparging technology that was applied in this demonstration is an extension of conventional biosparging techniques (Leeson et al, 1999). The approach involves the addition of oxygen (for aerobic respiration) and propane (as a cosubstrate) to simulate the production of the enzyme propane monooxygenase (PMO) by propane oxidizing bacteria (POB), which catalyzes the destruction of MTBE. The addition of the substrates to the contaminated aquifer creates an aerobic treatment zone that promotes the growth and activity of the POB. MTBE, the target contaminant, and its primary breakdown product, TBA, can be completely converted to carbon dioxide and water through this process. The remediation approach is illustrated conceptually in Figure 1. In some cases, POB may be added to the aquifer to ensure that sufficient MTBE-degrading microorganisms are present in the aquifer. Existing AS systems can be readily modified to inject propane and air or pure oxygen into the subsurface to stimulate MTBE degradation. This technology has been installed and demonstrated at small service stations, and has operated and been monitored without interfering with service station operations.

The propane biosparging technology can be deployed in a variety of configurations, as described in Section 2.2, to provide source area treatment or downgradient plume containment, depending on site characteristics and remediation needs, including:

1. A re-engineered or modified multi-point AS system that delivers propane and air or oxygen throughout a contaminated site (suitable for use with existing systems or specially designed systems)
2. A series of oxygen/propane delivery points arranged to form a permeable treatment wall to prevent off site migration of MTBE
3. A permeable treatment trench fitted with oxygen and propane injection systems
4. An in situ recirculating treatment cell that relies on pumping and reinjection to capture and treat a migrating contaminant plume (e.g., see Edwards AFB study; McCarty et al., 1998)

2.2 PROCESS DESCRIPTION

As noted above, propane biosparging can be applied to existing AS sites with minimal modification of existing systems. AS units can be modified to allow separate oxygen and propane addition, and timers and solenoid valves to regulate pulsed injection. Lower explosive limit (LEL) meters with automatic propane shut-off are required to ensure that buildup of explosive propane vapors does not occur. At sites where no treatment system exists, propane and AS points would have to be installed with the necessary control equipment. ENVIROGEN has a trailer mounted system that includes the injection delivery system, system manifold, and system monitoring equipment (the trailer system was in use at another site at the time of this demonstration). If nutrient or bacterial injection is required

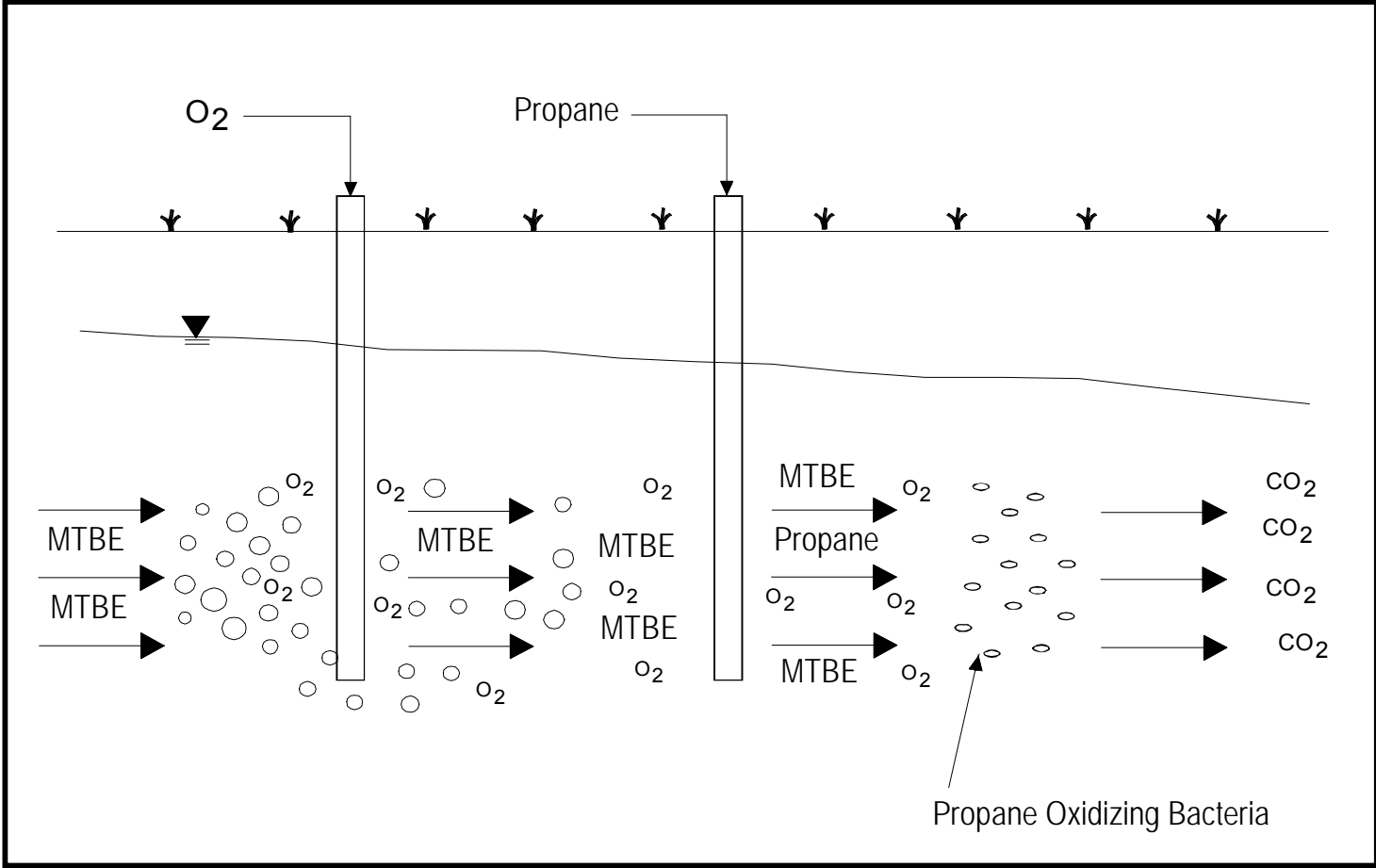

FIGURE 1
Conceptual Model of In Situ
Propane Biosparging

prior to or during system operation, air or propane injection wells can be temporarily used for this purpose. Monitoring wells (existing or newly installed) would be used to evaluate performance.

Oxygen and propane can be added to the contaminated aquifer through a variety of techniques including: (1) a conventional AS or biosparging with added propane; (2) pure oxygen and propane biosparging (the technique selected for the demonstration); (3) in-well diffusion of oxygen and propane using gas-permeable membranes or tubing; (4) in-well sparging or mixing system such as the UVB™ and NoVOCs™ systems; and (5) in situ recirculating treatment cells.

Pure oxygen and propane sparging methods operate in a biosparging or biostimulation mode. Oxygen and propane flow rates are designed to provide adequate substrate to create an aerobic treatment zone and stimulate enzyme production, while minimizing stripping of VOCs and offgassing of propane and oxygen. Much lower injection flow rates are required compared to conventional biosparging, as higher levels of dissolved oxygen can be achieved using pure oxygen as compared to air. As a result, the pure gas methods extend the application of the technology to lower permeability sites and sites with higher contaminant levels. Gases can be injected into conventional sparging wells, using permeable membranes or tubing, or using inwell sparging or mixing techniques. Because substrate mixing occurs within the saturated aquifer, soil vapor extraction (SVE) operation is typically not required.

Commercially available blowers and compressors can be used to deliver the air for oxygen supply in modified sparging systems. Pure oxygen can be supplied using pressurized gas cylinders for small sites when oxygen requirements are limited. Liquid oxygen storage tanks and on-site oxygen generation systems can be used for large site remediation. Propane is supplied using compressed gas cylinders or liquid propane tanks, depending on the system requirements.

Table 2 lists the key criteria for the design and operation of propane biosparging technology. Figures 2, 3, and 4 illustrate the demonstration area layout, including injection points and monitoring points, with detailed illustrations of the Test and Control Plots. The piping and instrumentation diagram for the system is presented in Figure 5. No specialized training costs are associated with the operation, maintenance, and monitoring of this type of system. Operation and maintenance (O&M) of the system is relatively simple, and the level of O&M required is similar to that of a typical AS system.

Table 2. Key Criteria for the Design and Operation of a Propane Biostimulation System.

Site Characteristics	Contaminant Characteristics	Operation Criteria
<ul style="list-style-type: none"> • Soil heterogeneity and presence of low permeability soils. • Hydraulic conductivity. • Groundwater gradient and flow direction. • Depth to water table and water table fluctuations. • Potential receptors (i.e., buildings, surface water, etc.). • Presence of nonaqueous phase liquids. • Geochemistry of groundwater (i.e., pH, dissolved metals, nutrients, etc.) • Existence of propane oxidizing bacteria. 	<ul style="list-style-type: none"> • Concentration of MTBE, TBA and other petroleum hydrocarbons. 	<ul style="list-style-type: none"> • Oxygen and propane distribution. • Gas injection pressures. • Dissolved oxygen and propane measurements. • Vadose zone VOC and propane concentrations. • Containment of sparged air.

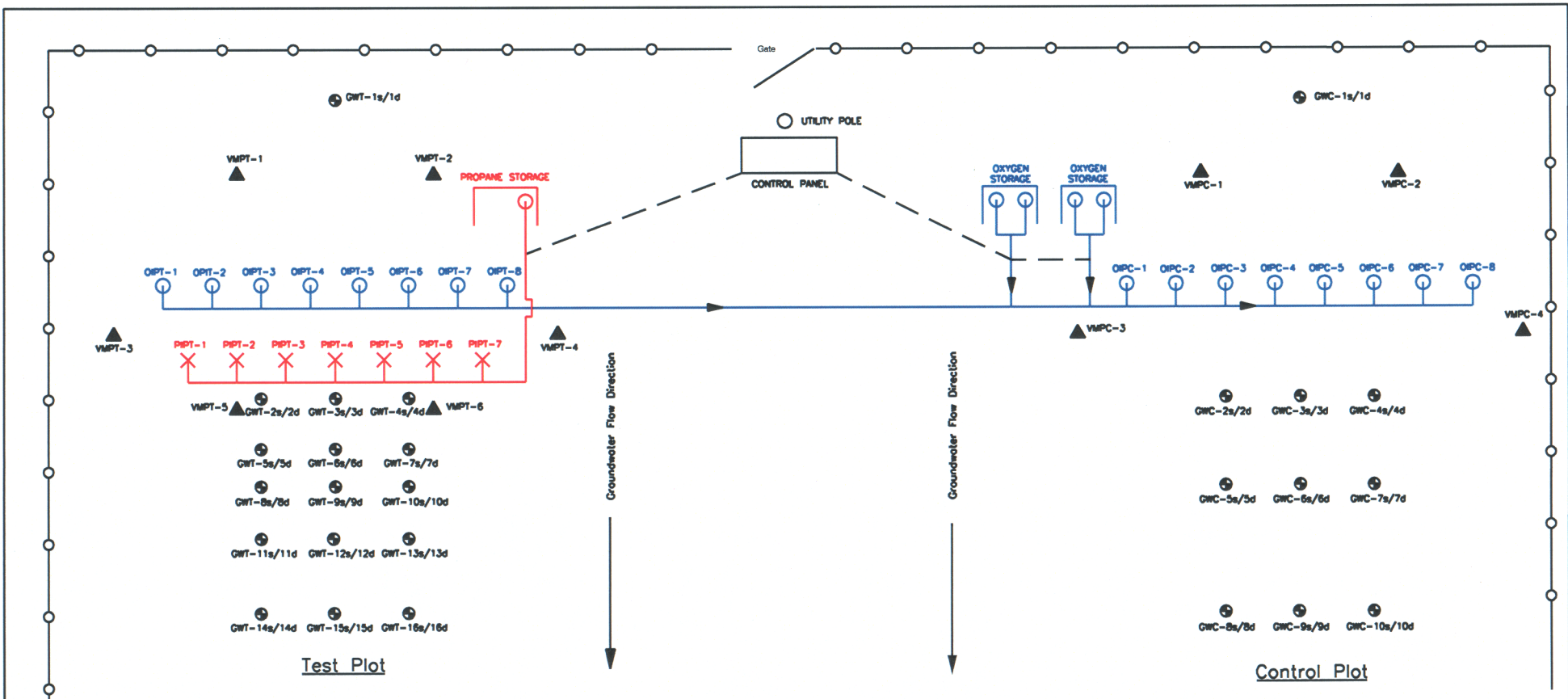

LEGEND

- ⊕ Groundwater Monitoring Well / Probe (GWT-1)
- Oxygen Injection Point (OIPT-1)
- × Propane Injection Point (PIPT-1)
- ▲ Vapor Monitoring Probe (VMPT-1)
- Oxygen Distribution System
- Propane Distribution System
- - 24 V Power For Solenoid Controls

NOTE: EPA monitoring network not shown. See Figures 6 and 7 for details.

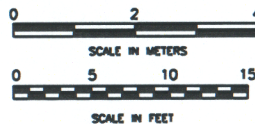

DRAWN BY SC,JS CHECKED BY JQ SCALE: 1" = 2 m DATE 08/30/00 APP'D BY ENGR'G APP'D BY PROJ. MGR. APP'D BY	<p>ENVIROGEN PRINCETON RESEARCH CENTER 4100 QUAMERSBRIDGE RD. LAWRENCEVILLE, N.J. 08648</p>	<p>ENVIROGEN PROJECT NO. 92132</p>
FIGURE 2 Demonstration Area Layout		Port Hueneme SIZE B DRAWING NO. demonstration area.dwg REV. A

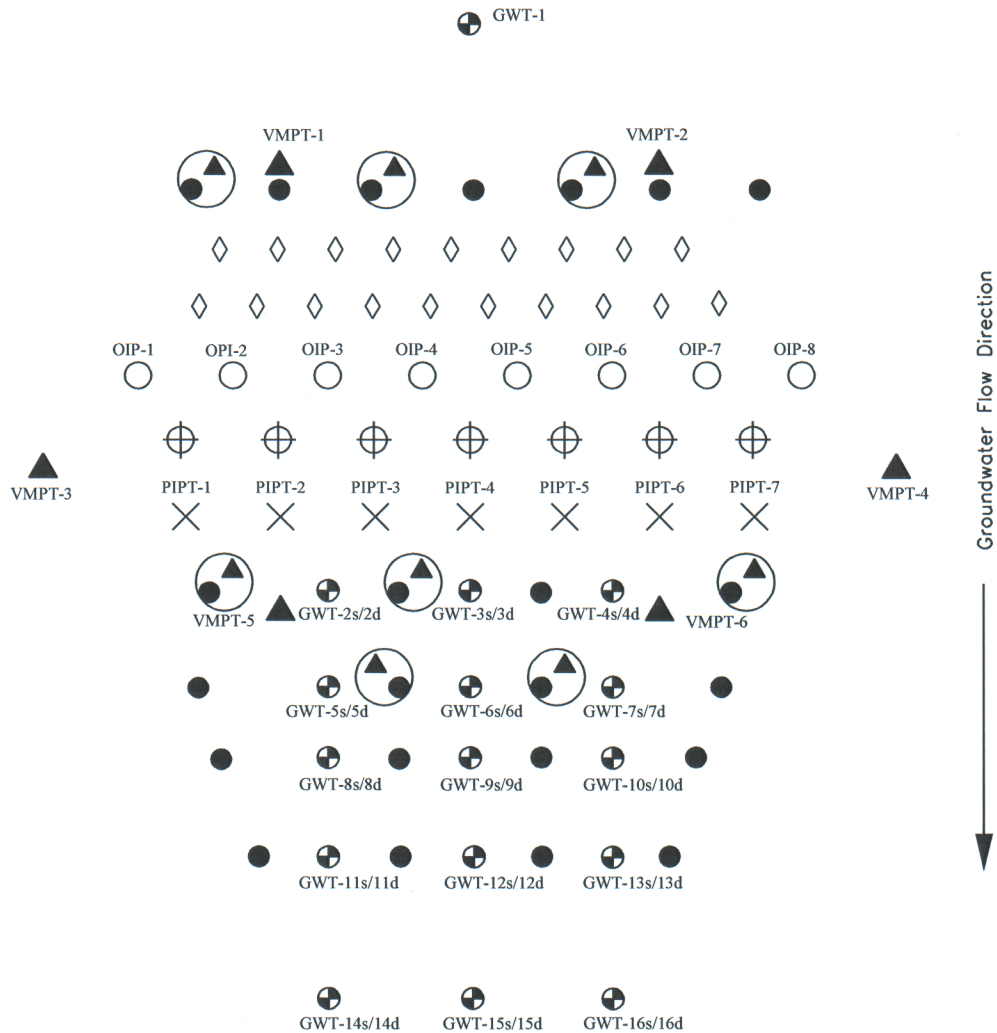

LEGEND

- ⊕ Dual-Level Groundwater Monitoring Well / Probe (GWT-1)
- Oxygen Injection Point (OIP-1)
- × Propane Injection Point (PIPT-1)
- ▲ Vapor Monitoring Probe (VMPT-1)
- ⊕ Bacteria Injection Point

EPA NETWORK

- Vapor Monitoring Probe
- 3 Level Groundwater Monitoring Point
- 3 Level Monitoring Point
- Tracer Injection Point

Note:
 Oxygen Injection Points are 1m on center.
 Propane Injection Points are 1m on center.
 Vapor Monitoring Probes are 4m on center.
 Groundwater Monitoring Wells are 1.75m on center.

Test Plot

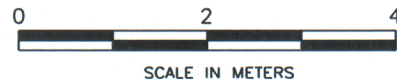

DRAWN BY	JS
CHK'D BY	JQ
SCALE:	1" = 2m
DATE	06/30/00
APP'D BY	
ENGR'G.	
PROJ. MGR.	
APP'D BY	



FIGURE 3
Demonstration Area Layout
for the Test Plot



ENVIROGEN PROJECT NO.
 92132

Port Hueneme

SIZE	DRAWING NO.	REV.
A	Figure 3.dwg	A

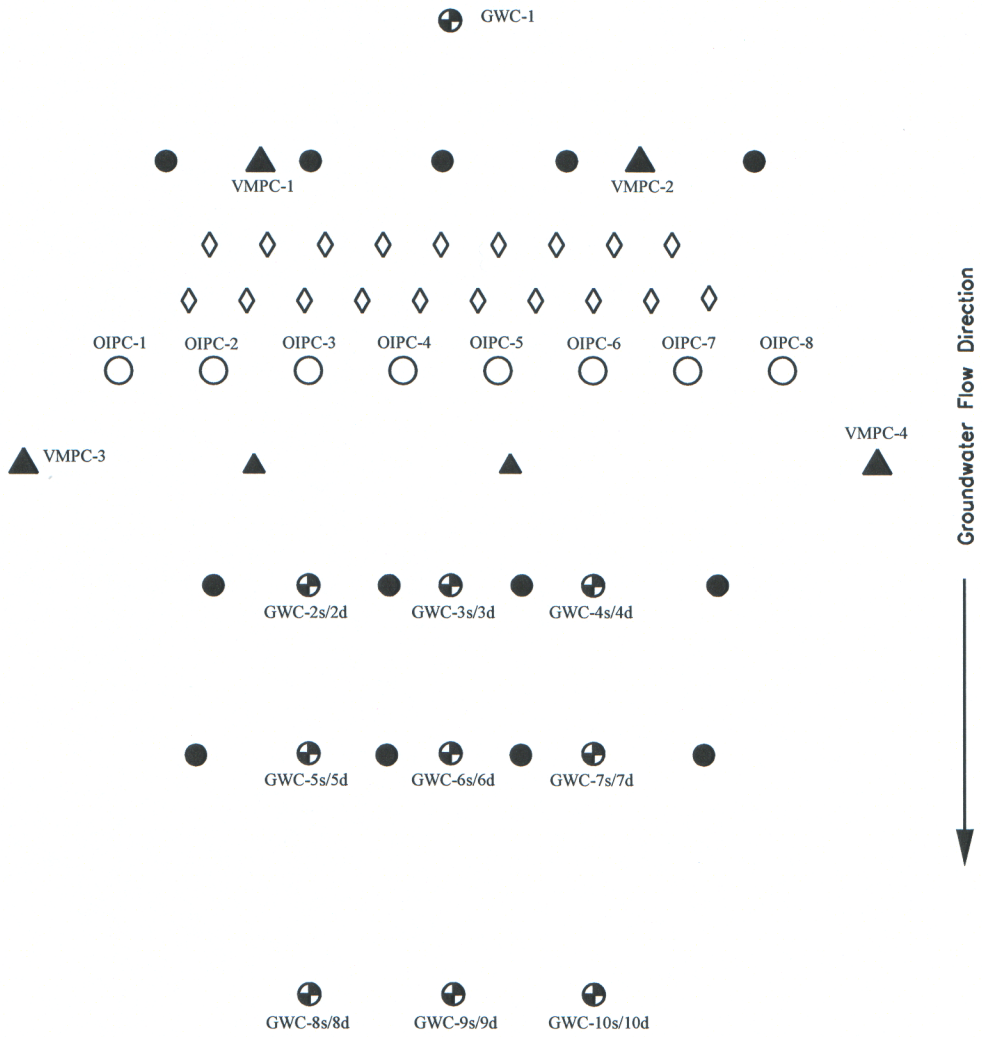

Control Plot

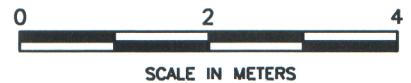

LEGEND

- ⊕ Dual-Level Groundwater Monitoring Well / Probe (GWC-1)
- Oxygen Injection Point (OIPC-1)
- × Propane Injection Point (PIPC-1)
- ▲ Vapor Monitoring Probe (VMPC-1)



EPA NETWORK

- 3 Level Groundwater Monitoring Point
 - ▲ Vapor Monitoring Probe
 - ◇ Tracer Injection Point
- Note:
 Oxygen Injection Points are 1m on center.
 Vapor Monitoring Probes are 4m on center.
 Groundwater Monitoring Wells are 1.75m on center.

DRAWN BY JS CHK'D BY JQ SCALE: 1" = 2m DATE 06/30/00 APP'D BY ENGR'G. APP'D BY PROJ. MGR. APP'D BY	 ENVIROGEN PRINCETON RESEARCH CENTER 4100 QUAKERBRIDGE RD. LAWRENCEVILLE, N.J. 08648	 ENVIROGEN PROJECT NO. 92132 Port Hueneme
FIGURE 4 Demonstration Area Layout for the Control Plot		SIZE A DRAWING NO. control plot.dwg REV. A

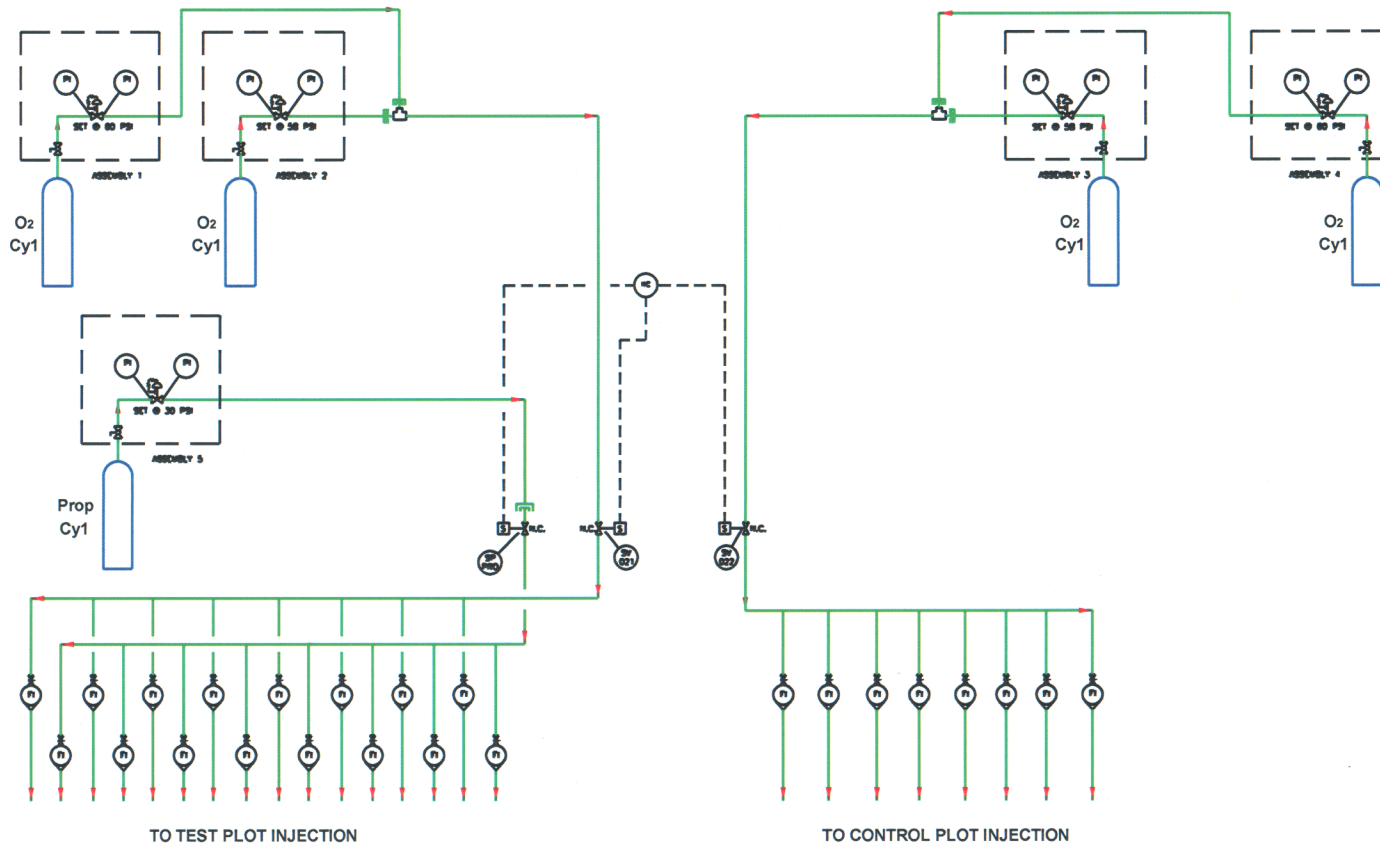

TO TEST PLOT INJECTION

TO CONTROL PLOT INJECTION

DRAWN BY LJJS
 CHK'D BY JQ
 SCALE: Not to Scale
 DATE 06/30/00
 APP'D BY
 ENGR'G
 APP'D BY
 PROJ. MGR.
 APP'D BY



FIGURE 5
 Propane Biosparging
 System Piping and
 Instrumentation Diagram



ENVIROGEN PROJECT NO.
 92132

Port Hueneme

SIZE	DRAWING NO.	REV.
B	pro_blastim.dwg	A

Routine system maintenance would typically involve weekly site visits, and would include maintenance to prevent silting and clogging of wells, ordering of propane tanks (and oxygen tanks if pure oxygen sparging is employed), maintenance of operating equipment, including compressors, solenoid valves, filters, etc. Sampling and monitoring activities may exceed a standard monitoring program, and personnel may have to be trained in low-flow groundwater sampling methods.

The use of propane requires consideration of safety issues surrounding the use of a potentially explosive gas. Typically, these concerns can be addressed by strict adherence to national and local safety codes. In most cases the risk involved should not be significantly greater than the risk of applying other technologies such as air stripping (sparging) of explosive gasoline mixtures. National electrical and safety codes should be followed, and the local fire department may be asked to review site and demonstration plans. Furthermore, pure oxygen injection and soil gas monitoring can be used to minimize the accumulation and fugitive emissions of propane. System-specific health and safety requirements include an understanding of system operation and the importance of vapor monitoring results as they apply to fugitive VOC and propane emissions.

2.3 ADVANTAGES AND LIMITATIONS OF THE TECHNOLOGY

Propane biosparging has several advantages over existing MTBE remediation technologies. The primary advantage is that the technology may be applied in situ to completely remediate MTBE and TBA without generation of waste products. Because propane biosparging technology is an extension of conventional AS and biosparging techniques, the existing knowledge base regarding their design and implementation allows simplified application of the technology. Moreover, addition of propane injection to existing or new systems can be accomplished with minimal added equipment and costs. Because the technology is complimentary to AS, biosparging treatment zones can be developed in conjunction with source treatment measures to address BTEX and other fuel hydrocarbons. If inhibition arises due to the presence of these compounds, the propane biosparging treatment zone can be established downgradient during source treatment and applied sequentially after BTEX compound concentrations are reduced.

Existing techniques, such as groundwater pump and treat or conventional AS combined with SVE, require ex situ treatment of generated groundwater and soil gas streams. MTBE's relatively high aqueous solubility in groundwater and low octanol-water partitioning coefficient allows groundwater pumping methods to be efficiently applied for source recovery and hydraulic control of dissolved-phase plumes. However, MTBE's relatively low Henry's law coefficient (HLC) limits the efficiency of water-to-air mass transfer processes such as air stripping, resulting in two- to five-times the air flow typically required to strip BTEX compounds (U.S. EPA, 1998). In addition, MTBE's low affinity for granular activated carbon adsorption (three to eight times less than benzene at similar concentrations) requires significantly more carbon for primary-treatment or secondary-polishing, resulting in comparably higher equipment and operating expenses for groundwater treatment (MTBE Research Partnership, 1998). MTBE's relatively high vapor pressure (approximately three times higher than benzene) and low adsorption affinity are favorable characteristics for source treatment via soil vapor extraction in the vadose zone. However, its high solubility and low HLC reduce its removal efficiency in the capillary fringe and in the saturated zone compared to the BTEX compounds, due to water-to-air mass transfer limitations associated with partitioning to the aqueous phase.

In situ biostimulation for co-metabolic degradation of groundwater contaminants has been applied in several well-publicized field demonstrations. Most notable are the use of biostimulation to degrade chlorinated solvents, including methane biostimulation at the Savannah River National Laboratory site (Hazen et al., 1994; Lombard, et al., 1994), methane (Semprini and McCarty, 1991, 1992; Semprini, et l., 1994), phenol (Hopkins et al., 1993; Hopkins and McCarty, 1995), toluene biostimulation at Moffett field (Hopkins and McCarty, 1995), toluene biostimulation at Edwards AFB (McCarty et al., 1998), and propane biostimulation at McClellan AFB (Tovanabootr et al., 2000). This technology can be used as both a source area treatment and as a biobarrier. Each of these demonstrations was successful, but some technological challenges were encountered during each project.

Although propane biosparging was used to treat a shallow aquifer during this demonstration, the presence of a deep water table could add to the cost and operating challenges of the technology. Also, as discussed earlier, the system would be less effective in aquifers with low hydraulic conductivities. The type of aquifers for which propane biosparging is most effective include those composed of sand to cobbles and with hydraulic conductivities greater than 10^{-4} cm/sec. The irregular distribution of oxygen and propane caused by heterogeneities could result in zones where little or no treatment can occur. Biochemical factors that must be present include microbes capable of degrading propane, MTBE, and TBA, the availability of nutrients, and a neutral pH.

One technological challenge observed for in situ biostimulation is biofouling of the aquifer formation. This is of greatest concern in fine-grained aquifer materials. Fouling is less of a concern, however, in formations with coarser aquifer soils. Because the Port Hueneme aquifer is primarily sand, it was expected that biofouling would be less of a concern than could be expected in other formations. Nonetheless, propane and oxygen were added through separate sparge points, and were added in pulses in an attempt to promote biomass production distant from the injection points.

Another technological challenge observed in prior field demonstrations was maintaining sufficient nutrient concentrations to support biomass growth as well as contaminant and substrate metabolism (Brockman et al., 1995, Tovanabootr et al., 2000). Therefore, in situ biostimulation requires monitoring of groundwater nutrient levels, and measurement of oxygen and substrate utilization rates as indicators of in situ biological activity. In some cases, injection of additional gaseous or liquid nutrients may be required.

ENVIROGEN's research suggests that MTBE oxidation in POB is facilitated by the propane monoxygenase (PMO) system. Because the PMO is required for both propane and MTBE oxidation, propane will likely be a competitive inhibitor of MTBE degradation. Consequently, the regulation of in situ propane concentrations is essential to efficiently degrade MTBE. To manage this limitation, propane concentrations must be monitored carefully and controlled until propane utilization rates exceed propane addition rates. For this project, propane was added to the aquifer in pulses, and propane was monitored to insure that dissolved propane concentrations remained low (i.e., preferably below detection). The extent of indigenous POB distribution in MTBE-contaminated aquifers may be another limitation, and some experiments with aquifer materials have failed to stimulate the growth and/or activity of MTBE degrading bacteria. Consequently, laboratory testing was performed to evaluate the feasibility of stimulating POB in situ and the need for adding exogenous seed cultures.

Like any other in situ remedial technology, propane biosparging can be affected by hydrogeological and hydrochemical conditions in the aquifer. For example, geological heterogeneity can affect the distribution of added propane, oxygen, or microorganisms. (Tovanabootr et al., 2000) Researchers observed little VOC degradation in areas of the McClellan AFB aquifer that did not receive adequate amounts of propane and oxygen due to in situ heterogeneity. Heterogeneity and hydrogeological conditions also can affect the distribution of seed cultures added to support degradation.

An additional concern is that explosive mixtures of propane and oxygen could collect in the subsurface, or be diverted away from the treatment zone by impermeable layers in the aquifer. Risks can be reduced by careful evaluation of the site hydrogeology, performing on-site pilot sparging tests, monitoring soil gasses, and, if needed, by applying SVE to minimize accumulation of gases. Likewise, extremes in geochemical conditions like pH levels <6 or >8 can reduce the activity of POB. Again, the suitability of the technology under existing site geochemical conditions, and methods for improving site conditions, can be evaluated by laboratory testing.

3.0 DEMONSTRATION DESIGN

3.1 PERFORMANCE OBJECTIVES

It is expected that the maximum contaminant levels (MCLs) for MTBE and TBA, at least in some states, will ultimately be set at or near 5 µg/L. Thus, for this demonstration, the goal of the treatment process was to reduce MTBE and TBA concentrations down gradient of the test plot to <5 µg/L, as stated in the Technology Demonstration Plan for this Site, *In-Situ Remediation of MTBE Contaminated Aquifers Using Propane Biostimulation*, October 17, 2000. The efficiency of the treatment process in reducing contaminant concentrations, and the incremental success of the process in the event that downgradient concentrations were not reduced to <5 µg/L, were to be determined by comparing treatment levels in the test plot with treatment levels achieved in the control plot. The U.S. EPA currently recommends 20 to 40 µg/L as the Health Advisory level for drinking water (U.S. EPA, 1998). The California Department of Environmental Health Services (DHS) has recently established a primary MCL for MTBE of 13 µg/L to protect public health and a secondary MCL of 5 µg/L to prevent taste and odor problems in groundwater (California DHS, 2002).

MTBE concentrations decreased in both the test and control plots during the demonstration. However, MTBE concentrations were reduced to less than 5 µg/L in only 3 of the 30 monitoring wells in the test plot and in none of the wells in the control plot. MTBE concentrations were reduced to less than 13 µg/L (the CA primary MCL) in 3 wells in each of the plots. MTBE concentrations were reduced to less than 40 µg/L (near the EPA-recommended Health Advisory level) in 8 of the wells in the test plot and in 7 of the wells in the control plot. Active MTBE degradation in the control plot prevented a thorough evaluation of the effectiveness of the MTBE degrading propanotrophs stimulated in this aquifer. At the end of the study, however, we were able to isolate several MTBE-degrading propanotrophs from the test plot, but none from the control plot. This suggests that propanotrophs did play a role in MTBE degradation in the test plot. Interestingly, the isolated propanotrophs did not have the same colony morphology as ENV425, suggesting that native propanotrophs increased in abundance and/or dominance in the aquifer during the course of the demonstration. Some of data collected near the end of the demonstration suggested that MTBE degradation activity in the control plot was declining. A longer demonstration may have allowed a better assessment of the stability and activity of the indigenous MTBE degrading population relative to the stimulated propanotrophs.

3.2 SELECTION OF TEST SITE

The following are the primary criteria that were used to select the demonstration location.

- Investigation data describing subsurface soils, historical groundwater table elevations, and contaminant distribution (some pre-demonstration subsurface characterization is assumed)
- A relatively permeable ($\geq 10^{-4}$ cm/sec) and homogeneous vadose zone and saturated zone
- A well characterized and simple groundwater flow regime
- Groundwater concentrations of MTBE in the 1,000 to 10,000 µg/L range
- Groundwater total BTEX concentrations of less than 100 µg/L
- No light non-aqueous phase liquid (LNAPL)
- Neutral pH

Additional secondary considerations for selecting the test area included:

- the availability and types of previously installed test wells;
- proximity to and types of previously installed test equipment (i.e., vacuum pumps, compressors, vapor treatment systems, etc.);
- the status of any previously required air permits;
- open area with sufficient clearing around the test plots; and
- potential for interference with or from normal day-to-day site activities.

The selected test site had an existing infrastructure and met many of the primary and secondary criteria. The site has been used for numerous demonstrations and was well-characterized.

3.3 TEST SITE HISTORY AND CHARACTERISTICS

The National Environmental Technology Test Site (NETTS) at the Naval Construction Battalion Center (NCBC), Port Hueneme, California, was chosen to host the propane biosparging technology demonstration. The NCBC is an active U.S. Navy site that enables the readiness of the Naval Construction Force (NCF) and other expeditionary units through the management and delivery of supplies, equipment, and specialized engineering and logistic support. The Port Hueneme NETTS facility is located approximately 70 miles northwest of Los Angeles. The Naval Exchange (NEX) service station is the source of the petroleum plume that occurs on the Port Hueneme NCBC facility. According to NEX inventory records, approximately 4,000 gallons of leaded and 6,800 gallons of unleaded premium gasoline were released from the distribution lines between September 1984 and March 1985. The resulting groundwater plume consists of approximately 9 acres of BTEX, extending 1,200 feet from the NEX service station, and approximately 36 additional acres of MTBE contamination, extending approximately 4,500 feet from the NEX service station. A map of the contaminant plume is presented in Figure 6.

Based on the primary and secondary criteria in Section 3.2, the plume area situated approximately 2,400 feet southwest of the NEX station was chosen for the demonstration. The location of ENVIROGEN's demonstration plot is shown in Figures 6 and 7. It is located adjacent to the existing University of California at Davis (U.C. Davis) and Equilon, Inc. demonstration plots. The ENVIROGEN plot was approximately 90 feet by 60 feet and included a test plot and a control plot. The geology and contaminant concentrations in this area are well characterized, as several soil borings, cone penetrometer test soundings and monitoring wells have been performed and sampled. Prior site characterizations include installation of four monitoring wells (CBC-43, CBC-44, CBC-45 and CBC-46) and nine cone penetrometer (CPT) soundings. Groundwater contamination consists primarily of MTBE and low levels of BTEX. In addition, groundwater flow direction and velocity have been monitored at the U.C. Davis and Equilon plots and at surrounding monitoring wells in conjunction with ongoing bioaugmentation studies. Moreover, performing the propane biosparging demonstration in close proximity to other biotechnology demonstrations allows direct comparison of degradation rates between the three demonstrations under similar hydrogeological conditions and contaminant concentrations.

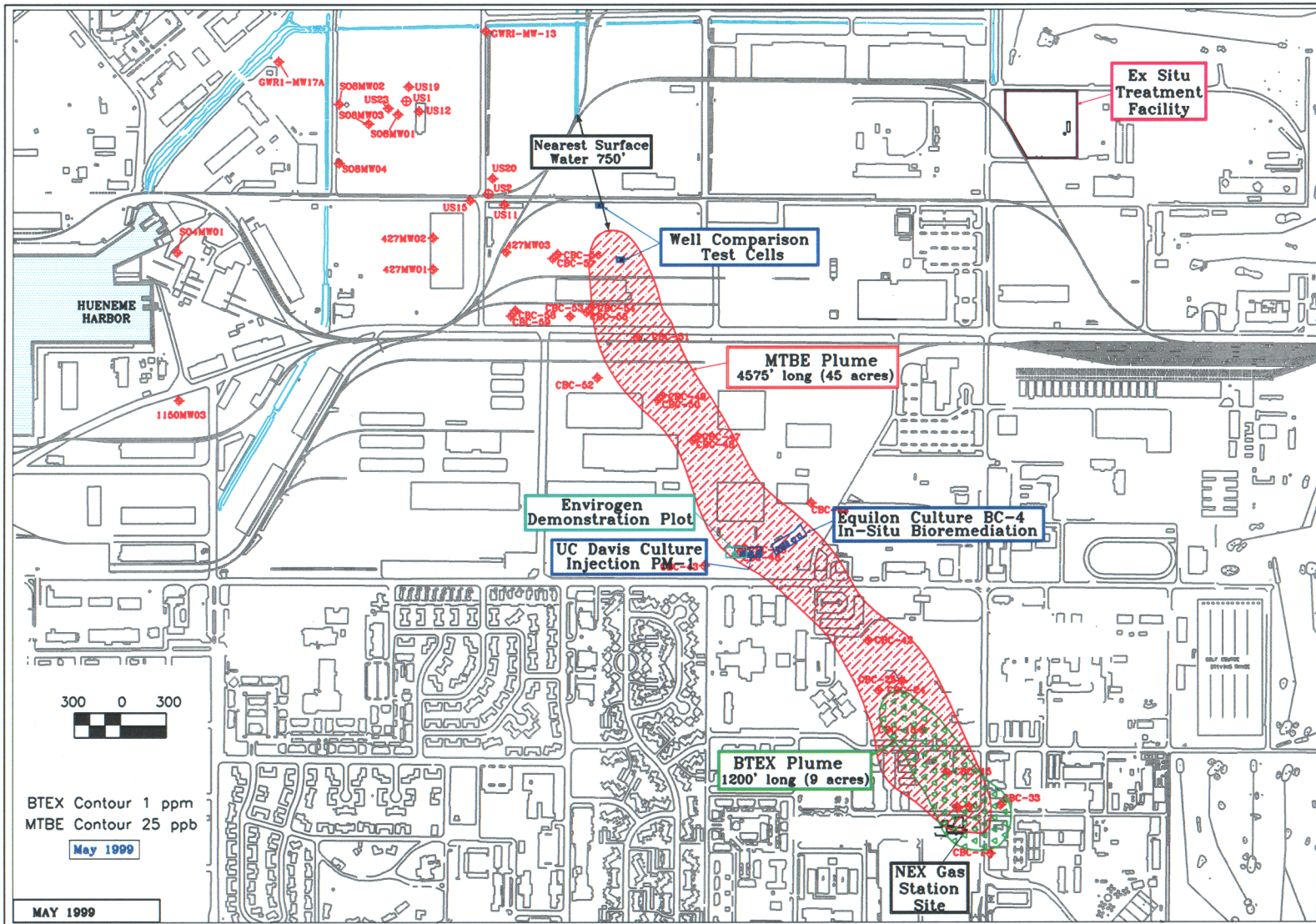

Princeton Research Center, 4100 Quakerbridge Road
Lawrenceville, New Jersey 08648



ESTCP - PROPANE BIOSTIMULATION WORKPLAN
PORT HUENEME, CALIFORNIA

FIGURE 6

Port Hueneme Plume Map

SCALE	AS SHOWN	SHEET SIZE	REVISION
DESIGNED BY/DATE		A	
DRAWN BY/DATE	JAS/06-30-00	FILE #	base map
CHECKED BY/DATE		FIGURE #	6
		SHEET	OF

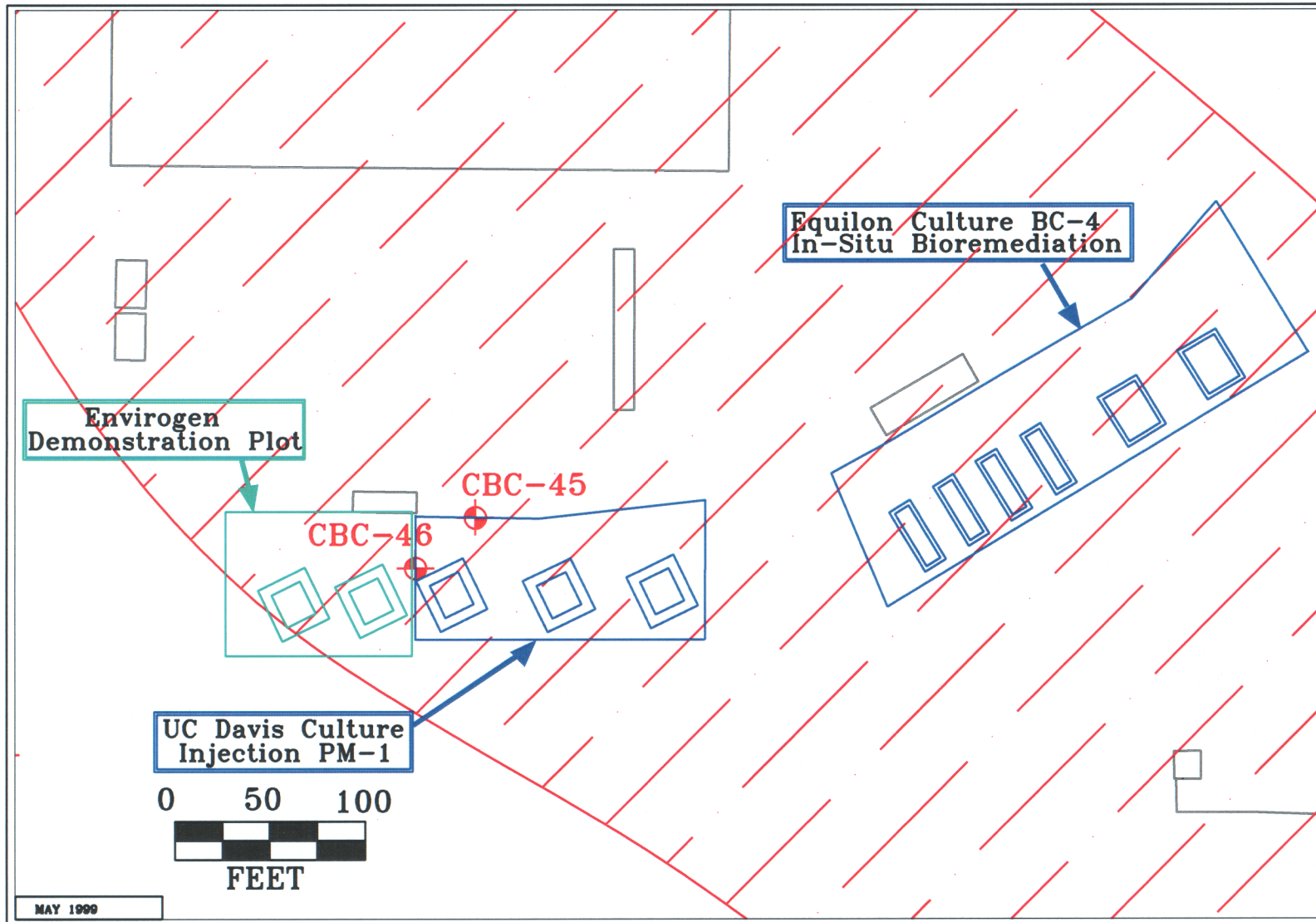

Princeton Research Center, 4100 Quakerbridge Road
Lawrenceville, New Jersey 08648



ESTCP - PROPANE BIOSTIMULATION WORKPLAN
PORT HUENEME, CALIFORNIA

FIGURE 7

Location of Test Plot

SCALE AS SHOWN	SHEET SIZE A	REVISION
DESIGNED BY/DATE	FILE # bose mop_closeup	
DRAWN BY/DATE JAS/06-30-00	FIGURE # 7	
CHECKED BY/DATE	SHEET 7	OF 7

The geology at the site consists of unconsolidated sediments composed of sands, silts, clays and minor amounts of gravel and fill material. A shallow, semi-perched, unconfined aquifer is the uppermost water-bearing unit. The shallow aquifer is comprised of three depositional units: an upper silty-sand, an underlying fine- to coarse- grained sand, and a basal clay layer. Based on CPT soundings, the upper silty-sand unit ranges between 8 to 10 feet thick and the underlying sand is approximately 12 to 15 feet thick. The water table is generally encountered at depths between 6 to 8 feet bgs, with seasonal fluctuations ranging between 1 and 2 feet, yielding a saturated aquifer thickness of 16 to 18 feet near the test area.

Groundwater contamination is limited to the semi-perched aquifer across the CBC facility. Monitoring wells CBC-45 and CBC-46 (see Figure 7) represent the groundwater quality conditions within the dissolved MTBE plume near the demonstration site. Historical groundwater sampling from these wells between September 1998 and September 1999 indicated MTBE concentrations ranging between 6,300 to 3,500 $\mu\text{g/l}$ at CBC-45 and 4,000 to 1,100 $\mu\text{g/l}$ at CBC-46. Apart from a TBA detection of 470 $\mu\text{g/l}$ at CBC-45 in June 1999, none of the other samples exhibited TBA or BTEX compound concentrations above their respective practical quantitation limits.

3.4 PHYSICAL SET-UP AND OPERATION

3.4.1 Microcosm Studies

Results of the microcosm studies conducted prior to the field demonstration suggested that the greatest likelihood of success would be achieved by performing the demonstration in the U.C. Davis area, which was the site ultimately chosen. The results also indicated that MTBE would likely be degraded by indigenous organisms at the site, which was consistent with the results of previous research (Salanitro et al. 2000). Like the Salanitro study, this microcosm study suggested that MTBE degradation by indigenous microbes would require a significant lag period. In the case of the unseeded microcosms used in this study, the lag period was at least 30 days, but Salanitro and colleagues reported a lag period of more than 200 days under field conditions. Conversely, if the microcosms were seeded with 10^8 CFU/ml of ENV425, there was essentially no lag period. Furthermore, the added microbes could degrade repeated additions of MTBE, and TBA accumulation was transient and minimal, provided MTBE loading rates were not excessive. Thus, the microcosm data indicated that propane oxidizing bacteria could be successfully employed to degrade MTBE in the Port Hueneme aquifer. They also suggested that degradation would be sufficiently faster in treatment plots seeded with ENV425 and fed propane than in plots fed only oxygen to measure the effect of the treatment relative to background levels of degradation by indigenous microbes.

3.4.2 Site Preparation

Because the demonstration location had been well characterized during prior site investigations (See Section 3.3) and the ongoing demonstration activities of other groups, a limited scope of testing was required prior to design and installation of the demonstration test and control plots. Site characterization confirmation sampling and analysis was completed in June 2000. Microcosm studies were conducted between June and December 2000. Monitoring wells, oxygen injection points (OIPs), PIPs, and bacterial injection points (BIPs), and vapor monitoring points (VMPs) were installed in September and October of 2000. Well and injection point development and pressure

testing were performed in October of 2000. Sparging manifolds were assembled and shipped to the site in January 2001. Sparge testing was conducted in May 2001. Tracer studies were conducted by the U.S. EPA from January to March 2001. The system control panel was fabricated and shipped to the demonstration site in April 2001. The individual control panel components were pre-assembled in a modular fashion for ease of shipping and field-assembly. The control panel system was assembled on-site by NETTS and ENVIROGEN personnel in April 2001. Final system connections and installation were made in April 2001. The first round of baseline sampling was conducted from January 9 to January 11, 2001, based on an expected March demonstration start up. However, permitting issues delayed start-up until May 2001. Because of the schedule delay, an additional round of baseline sampling was required. The second round of baseline sampling was conducted from April 30 to May 2, 2001, and the third round of sampling was conducted from May 21 to 23, 2001. A seed culture was added to the test plot subsurface through the BIPs on May 25, 2001. The first demonstration sampling event took place during the week of June 12, 2001.

3.4.3 Test and Control Plot Description

The demonstration system consisted of a network of oxygen and PIPs, pressurized oxygen and propane gas delivery and control systems, and groundwater and soil-gas monitoring networks constructed by ENVIROGEN. Figure 2 illustrates the layout of the demonstration system. In addition to the ENVIROGEN system, the U.S. EPA installed additional tracer injection wells, groundwater monitoring points and soil-gas monitoring points to facilitate performance monitoring. ENVIROGEN and NETTS personnel provided oversight during drilling, electrical and plumbing activities.

The test plot included a network of oxygen, propane, tracer, and bacteria injection wells, and groundwater and vapor monitoring networks, as shown in Figure 3. Eight OIPs, seven PIPs and seven BIPs were installed along a line oriented perpendicular to groundwater flow. The test plot groundwater performance monitoring network consisted of fifteen dual-level, nested wells. This network included one background well placed along the centerline of the plot upgradient of the OIPs. The remaining performance monitoring wells were placed in four rows of three nested wells each and one final row of two nested wells. Each set of nested wells included a “shallow” well and a “deep” well. ENVIROGEN’s soil-gas monitoring network consisted of six VMPs distributed around the OIPs and PIPs. In addition to ENVIROGEN’s monitoring network, the U.S. EPA installed 23 multilevel groundwater monitoring points, 8 soil-gas monitoring points, and 19 tracer injection points to allow collection of performance monitoring data.

The control plot was similar in configuration to the test plot, except that no PIPs or BIPs and few monitoring points were installed. The control plot configuration is illustrated in Figure 4. Eight OIPs were installed along a line oriented perpendicular to groundwater flow. The groundwater monitoring network consisted of 10 dual-level, nested wells. One well nest was placed upgradient of the OIPs. Three rows of performance monitoring wells were placed downgradient of the OIPs. The soil-gas monitoring network consisted of four VMPs placed around the OIPs. As in the test plot, the U.S. EPA installed thirteen multilevel groundwater monitoring points and two additional soil-gas monitoring points in the control plot.

3.4.4 Installation and Operation

OIPs, BIPs and PIPs were installed using Geoprobe™ methods to minimize soil cuttings and waste disposal. The OIPs, BIPs and PIPs were installed through the push rods using an expendable tip to anchor the assembly in the formation at the design depth. Oxygen and PIPs were constructed using 1-inch inner diameter (ID), Schedule 40 PVC casings from 2-feet above the ground surface to approximately 10-feet below the water table. The well screens were constructed using 1-foot length Schumaprobe™ screens composed of sintered polyethylene. BIPs were constructed of 2-inch ID, Schedule 40 PVC casings from 2-feet above the ground surface to the water table. BIP well screens were constructed using 2-inch, 0.010-foot slots screens of 10-foot length. The construction specifications for OIPs, BIPs, PIPs, monitoring wells and VMPs are presented in Figure 8.

Groundwater and soil-gas monitoring points were installed using the same techniques as described above. Shallow wells were designed to intersect the water table, with the top of the 5-foot screens placed approximately at the water table; deep wells were installed with 5-foot screens placed between 5 and 10 feet below the approximate water table elevation. Monitoring well screens were 0.5-inch ID, 0.010-foot slot, Schedule 40 PVC. Well casings were constructed of 0.5-inch ID Schedule 40 PVC from the top-of-screen to 2-feet above the ground surface. Because the injection and groundwater monitoring points were installed via direct push methods, no filter pack or annular seal was required. Soil-gas (vapor) monitoring points were constructed of 0.5-inch ID Schedule 40 PVC casings and 0.010-foot slot screens of 2.5-foot length. The screened section of the VMPs was placed approximately 2-feet below the ground surface and surrounded by a washed gravel filter pack and sealed above using bentonite chips to grade.

The system consisted of pressurized oxygen and propane tanks, individual oxygen and propane control manifold assemblies, and a control panel equipped with timers to allow pulsed operation of the injection systems. Figure 5 illustrates the piping and instrumentation diagram for the biosparging system. Separate oxygen distribution systems were set up for the test and control plots. Each plot utilized two oxygen cylinders (approximately 310 cubic feet of gas per cylinder) piped in series with appropriate pressure regulators to allow oxygen delivery at 40 to 60 pounds per square inch gage (PSIG). The test plot propane distribution system consisted of one 35-pound propane cylinder with appropriate pressure regulator to allow propane delivery at 20 to 30 PSIG. Oxygen and propane flow to their respective manifolds was controlled using timer actuated solenoid valves. Flow and operating pressure at each injection point well-head were controlled using individual needle valves. Each well head was equipped with a dedicated flow meter and pressure valve port to allow flow balancing and system performance monitoring. The primary distribution lines from the oxygen and propane tanks, manifold assemblies, and individual well-head distribution laterals were constructed of materials appropriate for oxygen and propane duty, respectively. The oxygen tanks for the control and test plots were housed in one cage located near the plots. The propane tank was housed in a separate cage near the test plot, separated from the oxygen tanks by approximately 25 feet.

The control panel was mounted on a portable, unistrut assembly placed near the plots and was properly anchored, grounded and protected from the elements. The demonstration system utilized 110V power supplied by NETTS. The propane solenoid valve was intrinsically safe, normally closed. The electric run from the timer switch to the propane solenoid valve was intrinsically safe, Class I, Division I.

**TYPICAL
OXYGEN / PROPANE
INJECTION POINT**

**TYPICAL
BACTERIA
INJECTION POINT**

**TYPICAL
GROUNDWATER
MONITORING POINT**

**TYPICAL
VAPOR
MONITORING POINT**

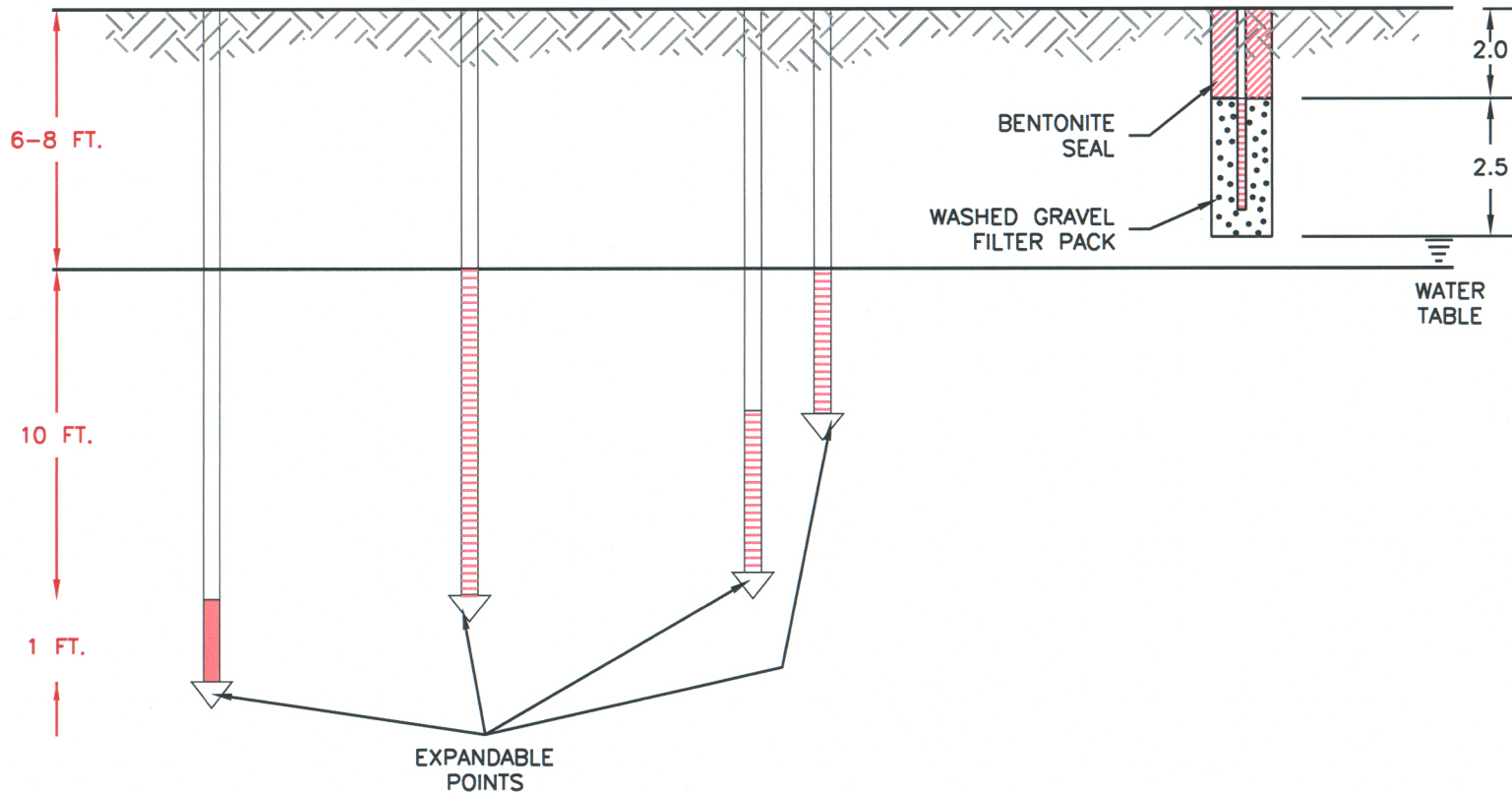

RISER: 1-INCH ID SCH.40 PVC
~ 16-18 FOOT LENGTH

2-INCH ID SCH.40 PVC
~ 6-8 FOOT LENGTH

1-INCH ID SCH.40 PVC
~ 6-13 FOOT LENGTH

0.5-INCH PVC RISER
W/ 10 SLOTS PER FOOT

SCREEN: 1-FOOT SCHUMA PROBE™
SINTERED POLYETHYLENE

2-INCH ID SCH.40 PVC
0.010 SLOT SCREEN
10 FOOT LENGTH

1-INCH ID SCH.40 PVC
0.010 SLOT SCREEN
5 FOOT LENGTH

0.5-INCH SCH.40 PVC
0.010 SLOT SCREEN
2.5 FOOT LENGTH



Princeton Research Center, 4100 Quakerbridge Road
Lawrenceville, New Jersey 08648



ESTCP - PROPANE BIOSTIMULATION WORKPLAN
PORT HUENEME, CALIFORNIA

FIGURE 8

Well Construction Specifications

SCALE NOT TO SCALE	SHEET SIZE A	REVISION
DESIGNED BY/DATE JQ/05-19-00	FILE # mtbe_demo	
DRAWN BY/DATE LJ, JS/06-30-00	FIGURE # 8	
CHECKED BY/DATE	SHEET	OF

The oxygen system operated for four, 6-minute cycles per day, yielding approximately 5 pounds of oxygen per day in the test and control plots. The propane system operated for four, 10-minute cycles per day and yielded approximately 0.5 pounds of propane per day at the test plot. After several months of operation and a review of the geochemical data, the propane flow was decreased from 1 cubic feet per hour at standard conditions (SCFH) to between 0.3 and 0.4 SCFH, corresponding to the addition of approximately 0.17 to 0.2 pounds of propane per day to the test plot.

3.5 SAMPLING, MONITORING, AND ANALYTICAL PROCEDURES

Sampling and monitoring procedures and analytical methods are described in the Sampling Plan, Section 7 of the Technology Demonstration Plan for this site, *In-Situ Remediation of MTBE Contaminated Aquifers Using Propane Biostimulation*, October 17, 2000.

Groundwater samples were collected in accordance with U.S. EPA Region I's "Low Stress (low flow) Purging and Sampling Procedure for the Collection of Groundwater Samples from Monitoring Wells." Samples were obtained using a peristaltic pump and dedicated polyethylene tubing for each point and a flow-through cell to allow field geochemical measurements [pH, oxygen reduction potential (ORP), temperature, specific conductivity, and dissolved oxygen]. Wells were purged for approximately 5-10 minutes so that three sets of geochemical data could be collected prior to sample collection. Well purging prior to sampling was limited so that no more than approximately 2.5 liters/ well/event were collected in order to minimize impacts on natural gradient flow patterns. All field meters were calibrated once at the beginning of the day and were checked periodically throughout the day to determine if re-calibration was required. All non-dedicated and non-disposable materials and equipment were properly decontaminated between wells. Groundwater elevation measurements were collected using an electronic water level indicator prior to collecting groundwater samples.

The groundwater sampling schedule outlined in Section 7 of the Technology Demonstration Plan was developed based on anticipated performance characteristics derived through preliminary modeling efforts. A tracer study was performed during the early phase of operation to quantify groundwater flow velocity and solute transport parameters to aid in system performance refinement. These data indicated that the velocity of groundwater flow was lower than predicted. The sampling schedule was modified based on the results of the tracer study, and based on additional sampling requirements of the California Regional Water Quality Control Board Monitoring and Reporting Program.

After system start-up (i.e., oxygen, propane and bacterial injections) groundwater samples were collected from both plots on a bi-weekly basis during the first two months and monthly thereafter for a period of eight months. Including the three "baseline" monitoring events, an additional twelve sampling events were conducted from June 12, 2001 through March 11, 2002, for a total of 15 sampling events. ENVIROGEN's sampling points (monitoring wells) are shown in Figures 3 and 4. During each groundwater sampling event, all monitoring wells (shallow and deep in both plots) were sampled for MTBE and TBA. Selected wells at both depths, representing the centerline of each plot (GWC-1 and -6 and GWT-1, -3, -9, and -15), were also sampled for ammonia nitrogen, total phosphate, total organic carbon, chemical oxygen demand, carbonaceous biological oxygen demand, alkalinity, anions, microbial populations, and dissolved carbon dioxide and propane. Additional analysis required by the California Water Quality Control Board but not included in the Technology Demonstration Plan included cations (barium, calcium, magnesium, manganese,

potassium, and sodium), total suspended solids and total dissolved solids. All appropriate QA/QC samples were collected and analyzed as per the Technology Demonstration Plan. The analytical methods used are listed in Table 3 of this report.

Table 3. Analytical Methods.

Sample Matrix	Analysis	Method	Container Type	Container Size	Preservative	Holding Time
Groundwater	VOCs	8260B	glass	40 ml (3)	HCl, cool (4°C)	7 days
	TBA	8015B (P/T)	glass	40 ml (2)	HCl, cool (4°C)	14 days
	Total Heterotrophs	SM 9215C	plastic	50 ml	None	24 hours
	Substrate Specific Heterotrophs	SM 9215C (modified)	plastic	50 ml	None	24 hours
	Carbon dioxide	SM 4500CO ₂	glass	40 ml (2)	None	14 days
	Propane	8015B	glass	40 ml (2)	None	14 days
	Anions (see below)	300	plastic	250 ml	cool (4°C)	48 hours
	Cations (see below)	(see EPA method below)	plastic	250 ml	cool (4°C)	6 months
	Phosphate (Total)	365.2	glass	250 ml	cool (4°C)	14 days
	Alkalinity	310.1	glass	120 ml	None	14 days
	Ammonia Nitrogen	350.2	glass	250 ml	H ₂ SO ₄	28 days
	TOC	415.1	glass	40 ml (2)	H ₂ SO ₄	28 days
	COD	410.4	glass	120 ml	H ₂ SO ₄	28 days
cBOD ₅	405.1	plastic	500 ml	None	48 hours	
Soil	VOCs	8260B	glass	4 ounce	MeOH, cool (4°C)	7 days
	TBA	8015 (P/T)	glass	4 ounce	None	14 days
	TOC	415.1	glass	120 ml	None	28 days
	Grain size	ASTM D421, D422	glass	1 L	None	N/A
Soil Vapor/Ambient Air Quality	VOCs	8260B	Tedlar bag	2-liter	None	7 days
	Propane	8015B	Tedlar bag	2-liter	None	7 days

NOTES:

Anions - Bromide, Chloride, Nitrite, Phosphate, and Sulfate

VOC - Volatile Organic Compounds

TBA - Tertiary Butyl Alcohol

Cations and (Method Number) - Ba (208.1), Ca (215.1), Mg (242.1), Mn (243.1), K (258.1), Na (273.1)

TOC - Total Organic Carbon

COD - Carbon Oxygen Demand

cBOD₅ - Carbonaceous Biological Oxygen Demand

DO - Dissolved Oxygen

T - Temperature

CO₂ - Carbon Dioxide

SC-Specific Conductivity

O₂-Oxygen

N/A-Not Applicable

As outlined in the Technology Demonstration Plan, field measurements of soil-gas were performed using a Gas Tech Flame Ionization Detector (FID) at each of the test and control plot vapor monitoring points (VMPs) to determine the total petroleum hydrocarbon concentrations. Soil-gas samples were collected in 2-liter Tedlar™ bags using a hand-held vacuum pump. The soil-gas measurements were compared to the LEL for propane, MTBE, and BTEX compounds. Based on field sampling and laboratory analysis, LELs were not exceeded at any time during pre-demonstration and demonstration activities. Concentrations of VOCs and propane in the breathing zone were monitored during each sampling event using the FID meter in the same manner as described for soil-gas monitoring. Four breathing zone samples were collected during each monitoring event: a sample collected upwind of the demonstration plot, a downwind sample and two side-wind samples. No readings above background were obtained from the FID for any of the breathing zone samples during predemonstration and demonstration activities. These monitoring data indicate that no fugitive emissions of VOCs or propane were present in the breathing zone.

This page left blank intentionally.

4.0 PERFORMANCE ASSESSMENT

4.1 PERFORMANCE DATA AND DATA ASSESSMENT

MTBE, TBA, and bacterial population data are discussed below. A summary of MTBE concentrations in the test and control plots (organized by rows of wells in Figures 2, 3, and 4) is presented in Table 1. Measured MTBE and TBA concentrations from all sampling events are presented in Tables 3 and 4, respectively, of the Final Report for this demonstration submitted January 3, 2003 (*In-Situ Remediation of MTBE Contaminated Aquifers Using Propane Biostimulation*). MTBE concentrations are also presented in Figures 9 and 10 of that report, and bacterial population data are presented in Figures 11 and 12 of that report. Additional data, including field parameters, groundwater elevations, ammonia nitrogen, total phosphate, TOC, COD, BOD, alkalinity, anions, cations, and dissolved carbon dioxide and propane, are presented in the Final Report for this project, *In-Situ Remediation of MTBE Contaminated Aquifers Using Propane Biostimulation*, January 3, 2002. A more detailed data analysis is included in that report as well.

NOTE: Test row 5 has only two wells. All other “Average” concentrations are the average of three wells.

MTBE concentrations decreased in the test plot shallow wells from 62 to 88% over the course of the demonstration. Decreases in the deep wells were slightly greater, ranging from 86 to 96%. In the control plot, similar reductions in MTBE concentrations were observed, from 86 to 97% in the shallow wells and from 88 to 90% in the deep wells. These data indicate that biodegradation occurred in the control plot as well as in the test plot. Data from both shallow and deep wells show a decreasing trend in MTBE concentrations over the duration of the demonstration. These results indicate that indigenous bacteria at this site are capable of aerobically degrading MTBE.

Active MTBE degradation in the Control Plot prevented a thorough evaluation of the effectiveness of the MTBE degrading propanotrophs stimulated in this study. At the end of the field demonstration, however, we were able to isolate several MTBE-degrading propanotrophs from the test plot, but none from the control plot. This suggests that propanotrophs did play a role in MTBE degradation in the Test Plot. Interestingly, the isolated propanotrophs did not have the same colony morphology as ENV425, suggesting that native propanotrophs increased in abundance and/or dominance in the aquifer during the course of the demonstration.

The average calculated half-life for MTBE in the test plot was approximately four times larger than that in the control plot. However, reductions in MTBE concentrations in the test plot were more consistent than those in the control plot. The regression parameter, R², for the test plot ranged between 0.54 and 0.87. For the control plot, R² ranged between 0.09 and 0.96. Comparison of the MTBE degradation rates between the plots in this demonstration may be misleading and they should not be considered definitive. MTBE concentrations entering the plots decreased during the treatment period, but they were always greater in the control plot. As with any degradative system that appears to follow first order kinetics, higher degradation rates are expected at higher contaminant concentrations. Thus, higher degradation rates would be expected in the control plot. Similarly, the calculations used to estimate in situ degradation rates in this studies are dependent on groundwater flow velocity. Results of groundwater elevation measurements during the study, and tracer test results, clearly demonstrate significant flow variation both spatially and with time. In

fact, groundwater elevation measurements suggested that flow in the test plot may have reversed at times during the treatment period, demonstrating that the calculated rates can not be exact. Furthermore, it is unlikely that the addition of propane significantly slowed degradation of MTBE in the test plot, or that propane degraders degraded MTBE more slowly than the native MTBE degraders. During this demonstration, efforts were made to ensure that propane concentrations remained at or near the limit of their detection to minimize competitive inhibition, and laboratory studies with pure cultures suggest that propanotrophs degrade MTBE (Steffan et al., 1997) at rates comparable to those achieved with organisms that grow on MTBE as a carbon source (Hanson et al., 1999; Hatzinger et al., 2001).

The concentrations of TBA in test plot wells, both shallow and deep, were generally below 25 µg/L. During the May 2001 sampling event (immediately before bioaugmentation), TBA was detected at low levels in only 5 of the 30 monitoring wells in the test plot. By the end of the demonstration in March 2002, TBA was detected at low concentrations in 19 of the 30 monitoring wells in this plot. This occurrence of TBA was likely the result of MTBE degradation in the plots which was expected based upon the laboratory microcosm studies, and our previous analysis of the MTBE degradation pathway of ENV425 (Steffan et al., 1997). Our microcosm studies, however, revealed that TBA is degraded in the site aquifer material provided MTBE loading is not too great. Thus, it is likely that much of the TBA generated during MTBE degradation at the site also was biodegraded in situ, and that biodegradation could reduce TBA to below analytical detection limits. In some cases, however, TBA levels in the test plot exceeded the California regulatory limit of 12 µg/L. Thus, in an actual remedial application, system operation should be better optimized to ensure complete TBA removal before migration of the groundwater off site. This might be accomplished by placing the system a sufficient distance from the site boundary to allow further degradation or dilution of the TBA before off-site migration, or by adding an additional row of down gradient treatment wells to allow further TBA degradation.

4.2 CONCLUSIONS

MTBE concentrations decreased in both the test and control plots during the demonstration. However, MTBE concentrations were reduced to less than 5 µg/L in only 3 of the 30 monitoring wells in the test plot and in none of the wells in the control plot. Active MTBE degradation in the control plot prevented a thorough evaluation of the effectiveness of the MTBE degrading propanotrophs stimulated in this aquifer. However, we were able to isolate several MTBE degrading propanotrophs from the test plot, but none from the control plot. This suggests that propanotrophs did play a role in MTBE degradation in the test plot. The morphology of the isolated propanotroph colonies suggest that native propanotrophs increased in abundance and/or dominance in the aquifer during the course of the demonstration. Some of the data collected near the end of the demonstration suggested that MTBE degradation activity in the control plot was declining. A longer demonstration may have allowed a better assessment of the stability and activity of the indigenous MTBE degrading population relative to the stimulated propanotrophs.

Addition of oxygen to the control plot resulted in more rapid MTBE degradation than was anticipated based on microcosm studies performed by others and ENVIROGEN, and based on prior demonstrations at the site. This high level of activity in the control plot frustrated analysis of the effect of propane biosparging on MTBE degradation at the site. Likewise, changes in the groundwater flow also made analysis of the degradation rate data difficult. For example, because in situ degradation rate calculations are determined based on groundwater flow rates, and because

the hydraulic gradient was flat and the flow was low at the site, even small variations in flow could significantly affect degradation rate calculations. Groundwater elevation data (see Final Report for data) suggested that groundwater reversed flow direction periodically during the study, especially in the test plot. Similarly, calculations of first order MTBE degradation rates are affected by influent MTBE concentrations with higher rates expected with higher MTBE concentrations. Because influent MTBE concentrations were greater in the control plot than the test plot, calculated MTBE degradation rates were higher in the control plot. Thus, caution is needed when comparing the MTBE degradation rates between the two plots.

Application of propane biosparging technology resulted in no measurable fugitive emissions of propane, and in situ biodegradation maintained propane levels near or below its detection limit in groundwater. Propane costs for the 10-month demonstration were only about \$50/month, indicating that application of this technology costs little more than a traditional AS system. Because of low propane emissions, the technology should not require secondary containment systems (e.g., soil vapor extraction) in most cases. Thus, it may be cost effective to incorporate propane biosparging equipment into MTBE remediation designs, even at sites where MTBE biodegradation by indigenous organisms is suspected. If indigenous bacteria prove to be inefficient or ineffective at remediating the site, propane can be injected to enhance activity at minimal additional cost.

Results of this study also demonstrated that most of the active MTBE degradation that occurred in both plots occurred near the oxygen injection points. This limit of degradation activity was probably caused by consumption of the oxygen added to the plot. Oxygen was likely consumed by both geochemical oxygen sinks and biological activity. Because of the process monitoring and technology validation procedures of both ENVIROGEN and the U.S. EPA, researchers elected not to increase gas flows into the site during this demonstration. To reach even lower MTBE levels, however, either additional rows of oxygen injection points may be needed, or oxygen loading rates may need to be increased.

No significant deviations from the Technology Demonstration Plan, *In-Situ Remediation of MTBE Contaminated Aquifers Using Propane Biostimulation*, October 17, 2000, occurred during this demonstration. As stated previously, additional sampling was conducted as required by the California Water Quality Control Board. Adjustments to propane flow rates were made several months after the start of the study, but were maintained within the ranges stated in the Demonstration Plan.

No specialized training costs are associated with the operation, maintenance, and monitoring of this type of system. As expected, operation and maintenance of the system was relatively simple, and the level of O&M required is similar to that of a typical AS system. Routine system maintenance was performed by Navy personnel and typically involved regular site visits and ordering of propane and oxygen tanks. Other O&M activities would include maintenance of operating equipment, including compressors, solenoid valves, filters, etc. Sampling and monitoring activities exceeded a standard monitoring program, and personnel would have to be trained in low-flow groundwater sampling methods.

This page left blank intentionally.

5.0 COST ASSESSMENT

5.1 COST REPORTING

5.1.1 Reported Demonstration

The actual demonstration costs are presented in Table 4 in the format recommended in the guidance document for this report (ESTCP, 2000). The actual demonstration costs were estimated based on a review of the billing records from the time of work plan preparation through the completion of the project. Costs for report revisions not yet completed were estimated. The demonstration costs were estimated at approximately \$333,000. These high costs are in part due to the fact that this was a first-time demonstration of the technology for many of the personnel involved, the distance between the managing office (NJ) and the site (CA), and the time taken to prepare the work plan and deal with regulatory considerations. The delay in permitting of the project and the additional sampling required under the permit also added unexpected cost.

Table 4. Actual Demonstration Costs.

Capital Costs		
1	Mobilization/Demobilization	\$ 12,820
2	Planning/Preparation (Labor)	\$ 34,994
3	Equipment Cost	\$ 21,597
4	Start-up and Testing	\$ 15,898
5	Engineering	\$ 16,440
6	Management Support	\$ 5,404
7	Travel	\$ 15,157
	Sub-Total (\$)	\$122,311
Operation and Maintenance Costs		
1	Labor	\$ 12,054
2	Materials and Consumables (including propane)	\$ 9,736
3	Utilities	\$ 649
4	Equipment Rental (GW collection and monitoring)	\$ 18,620
5	Performance Testing/Analysis*	\$ 86,988
6	Shipping of GW Samples	\$ 9,924
7	Report Writing	\$ 18,785
8	Out-of-house Analytical	\$ 14,873
9	CA State Tax on Purchases	\$ 2,047
10	Management Support	\$ 10,972
	Sub-Total (\$)	\$184,647
Other Technology-Specific Costs		
1	Treatability Studies	\$ 26,329
	Sub-Total (\$)	\$ 26,329
	Total Costs (\$)	\$333,288

*This cost includes sampling and analysis, data analysis, and data management.

5.1.2 Subsequent Demonstration

Table 5 presents the estimated costs for a real-world implementation of the technology at the scale of the demonstration, as required by the guidance document for this report. These costs were estimated at approximately \$145,600, which is approximately 44 percent of the cost of the reported demonstration. These costs were estimated by breaking out costs that were incurred in this demonstration solely because the effort was a demonstration of the innovative technology. These costs would not be expected to be incurred for a subsequent implementation. Several of the cost items were reduced to approximately 50 to 80 percent of the demonstration costs to reflect improved efficiency expected to be realized in a subsequent implementation of the technology. Performance testing and analysis costs would be significantly reduced in a subsequent demonstration because the non-routine analysis and excessive sampling and analysis costs incurred during the original demonstration may not be required (i.e., 15 thorough sampling events with an extensive parameter list were conducted in this demonstration). Reporting costs may also be significantly reduced in a subsequent implementation.

Table 5. Costs for Demonstration-Scale Implementation.

Capital Costs		
1	Mobilization/Demobilization	\$10,256
2	Planning/Preparation (Labor)	\$17,497
3	Equipment Cost	\$19,438
4	Start-up and Testing	\$11,129
5	Engineering	\$ 9,864
6	Management Support	\$ 3,243
7	Travel	\$ 5,002
	Sub-Total (\$)	\$76,428
Operation and Maintenance Costs		
1	Labor	\$ 9,643
2	Materials and Consumables (including propane)	\$ 7,789
3	Utilities	\$ 649
4	Equipment Rental (GW collection and monitoring)	\$ 4,965
5	Performance Testing/Analysis*	\$23,197
6	Shipping of GW Samples	\$ 496
7	Report Writing	\$ 3,757
8	Out-of-house Analytical	\$ 3,966
9	Management Support	\$ 5,486
	Sub-Total (\$)	\$59,948
Other Technology-Specific Costs		
1	Treatability Studies	\$ 9,215
	Sub-Total (\$)	\$ 9,215
	Total Costs (\$)	\$145,591

*This cost includes sampling and analysis, data analysis, and data management.

5.1.3 Full-Scale

The following presents a cost comparison between full-scale propane biosparging biobarrier, full-scale application of biosparging to treat the entire site simultaneously, and pump and treat for the remediation of contaminated groundwater at a typical gas station. The cost comparison was performed in accordance with the guidance document for this report (ESTCP, 2000). In general, liability costs are expected to be lower for propane biosparging technology than for alternate technologies. This is because alternate technologies, such as air stripping and carbon adsorption, simply transfer contaminant from the aqueous phase to the solid phase. The solid phase must then be treated and/or disposed of, raising waste handling and liability costs. Successful propane biosparging, on the other hand, results in complete destruction of the MTBE and TBA molecules, reducing or eliminating associated waste handling and liability costs.

The treatment efficiency of a propane biosparging system is expected to be greater than the efficiency of alternate technologies. This increased efficiency could result in significant cost savings in the long term. Historically, the most common treatment technology for groundwater contamination has been a pump and treat approach. Because of the high aqueous solubility of MTBE, its low Henry's Law Constant (low volatility from water) and poor adsorption to carbon, the usual ex situ treatment techniques designed for contaminants such as benzene and trichloroethylene have proven ineffective for removal of MTBE from groundwater. Despite poor removal, air stripping is often considered to be the most effective and economical method for remediating MTBE-contaminated groundwater (Keller et al., 1998). The use of air stripping and carbon adsorption is even less useful in regions of the country where TBA levels in groundwater are regulated, because TBA strips more poorly than MTBE, and it has a lower affinity for activated carbon.

The following sections present a cost comparison between propane biosparging biobarrier, biosparging of the entire site, and pump and treat for the remediation of contaminated groundwater at a typical gas station. The following assumptions are made for the gas station remediation.

- The service station area is 100 ft. x 60 ft. with the remediation area measuring 60 ft. x 60 ft.
- The subsurface soil is a medium sand with a porosity of 0.3 and the depth to groundwater is 10 ft. below grade (bg).
- The vertical extent of the groundwater contamination is 10 ft. below the groundwater. Thus, the volume of groundwater to be treated is 81,000 gal. The volume of saturated soil that is contaminated is 1330 yd³.
- The BTEX/MTBE concentration in the groundwater in the source area is 60 ppm with the primary contaminant being MTBE.

5.1.3.1 Cost Estimate for Propane Biosparging Biobarrier

The following assumptions are made for the installation and O&M of the biosparging system.

- Three AS/PIPs installed to 10 ft. below groundwater
- Four monitoring wells installed to 10 ft. below groundwater
- Four vapor monitoring points installed to 1 ft. above groundwater
- Estimated 70 ft. of piping to injection points installed below grade

- Biosparging system trailer with AS blower, propane tank, piping, instrumentation and control panel

The tasks for implementing the design, installation, and O&M of the system are as follows.

- *Design* — Design of system, preparation of application for Discharge to Groundwater Permit, one meeting.
- *Procurement and mobilization* — Procurement of equipment and materials, preparation for mobilization, and mobilization.
- *Installation* — Installation of AS points, monitoring wells, trenching, pipe installation, backfilling, surface restoration, connection to system, electrical connection, disposal of soils from trench.
- *Baseline monitoring* — Baseline monitoring of VOCs, geochemical, and biological parameters in monitoring wells. Injection of MTBE degrading bacteria and/or buffer solution, if needed.
- *Start-up* — Start-up of system, three days of start-up surveillance and monitoring to maximize performance of the system, and letter report.
- *Monitoring* — Quarterly monitoring of VOCs, geochemical, and biological parameters in monitoring wells. Injection of MTBE degrading bacteria and/or buffer solution if needed. Weekly visits for system inspection and balancing. Quarterly report.
- *Demobilization* — Disconnect and dismantle system, remove system from site.
- *Final Report* — Final letter report prepared and submitted to client.

A summary of the costs for the propane biosparging system is presented in Table 6 with a breakdown of capital, operation and maintenance, and other technology specific costs. The total cost is based on the time needed to remediate the groundwater to a typical cleanup objective (70 ppb) and estimated from degradation rates from other sites. The time to remediate the groundwater to the cleanup objective is estimated to be two years. Based on a two year remediation, the total life-cycle cost for the project is estimated to be \$171,600 +/- 20%. The life-cycle cost is reported as the net present value (NPV) using a 4% discount factor as recommended by the Office of Management and Budget (OMB). At a volume of contaminated groundwater of 81,000 gallons and volume of contaminated saturated soil of 1330 cy³, the unit cost to remediate these media are \$2.12/gal and \$129/cy³, respectively.

The following assumptions were made for the cost estimate.

- The AS system will operate four times a day at 0.5 hour each time for a total operating time of two hours/day.
- The site is near ENVIROGEN's office and per diems are not needed.
- If a bacterial injection is needed, the additional cost is \$1,000 per event.
- The biosparging system will be leased to the project.

Table 6. Cost Reporting for MTBE Remediation with Propane Biosparging (Biobarrier).

1. Capital Costs	Cost (\$)
Mobilization/Demobilization	\$ 6,100.00
Planning/Preparation	\$12,000.00
Site Work	\$ 6,300.00
Equipment Enclosure	\$ --
Process Equipment	\$ --
Baseline Monitoring	\$ 2,600.00
Start-up and Testing	\$ 3,200.00
Installation	\$37,300.00
Engineering	\$14,500.00
Management Support	\$15,400.00
Sub-Total (\$)	\$97,400.00

Variable Costs	Per Year	PV at 4%
2. Operation and Maintenance		
Labor	\$24,540.00	\$46,135.20
Materials and Consumables	\$ 110.00	\$ 206.80
Utilities and Fuel	\$ 1,720.00	\$ 3,233.60
Equipment Cost	\$ 3,000.00	\$ 5,640.00
Performance Testing		
Other Direct Costs	\$ 5,270.00	\$ 9,907.60
		\$65,123.20

Variable Costs	Per Year	PV at 4%
3. Other Technology-Specific Costs		
Long-Term Monitoring	\$2,960.00	\$ 5,564.80
Regulatory/Institutional Oversight	\$1,600.00	\$ 3,008.00
Compliance Testing		
Soil Collection and Control	\$ 550.00	\$ 550.00 (CAPITAL COST)
Disposal of Residues		
		\$ 9,122.80

TOTAL TECHNOLOGY COST	\$171,646.00
ROUND	\$171,600.00
QUANTITY GROUNDWATER TREATED (GAL)	\$ 81,000.00
UNIT COST (PER GAL)	\$ 2.12
QUANTITY SOIL TREATED (CY)	\$ 1,330.00
UNIT COST (PER CY)	\$ 129.06

NOTE:

Total price for site remediation is based on two years of operation.

Present value based on 4% discount recommended by OMB.

5.1.3.2 Cost Estimate for Propane Biosparging (Simultaneous Treatment of the Entire Site)

The following assumptions are made for the installation and O&M of the biostimulation system to treat the entire site.

- Six AS/PIPs installed to 10 ft. below groundwater
- Monitoring wells installed to 10 ft. below groundwater
- Vapor monitoring points installed to 1 ft. above groundwater
- Estimated 200 ft. of piping to injection points installed below grade
- Biostimulation system trailer with AS blower, propane tank, piping, instrumentation and control panel

The tasks for implementing the design, installation, and O&M of the system are as follows.

- *Design* — Design of system, preparation of application for Discharge to Groundwater Permit, one meeting.
- *Procurement and mobilization* — Procurement of equipment and materials, preparation for mobilization, and mobilization.
- *Installation* — Installation of AS points, monitoring wells, trenching, pipe installation, backfilling, surface restoration, connection to system, electrical connection, disposal of soils from trench.
- *Baseline monitoring* — Baseline monitoring of VOCs, geochemical, and biological parameters in monitoring wells. Injection of MTBE degrading bacteria and/or buffer solution, if needed.
- *Start-up* — Start-up of system, three days of start-up surveillance and monitoring to maximize performance of the system, and letter report.
- *Monitoring* — Quarterly monitoring of VOCs, geochemical, and biological parameters in monitoring wells. Injection of MTBE degrading bacteria and/or buffer solution if needed. Weekly visits for system inspection and balancing. Quarterly report.
- *Demobilization* — Disconnect and dismantle system, remove system from site.
- *Final Report* — Final letter report prepared and submitted to client.

A summary of the costs for the propane biostimulation system is presented in Table 7 with a breakdown of capital, operation and maintenance, and other technology specific costs. The total cost is based on the time needed to remediate the groundwater to a typical cleanup objective (70 ppb) and estimated from degradation rates from other sites. The time to remediate the groundwater to the cleanup objective is estimated to be two years. Based on a two year remediation, the total life-cycle cost for the project is estimated to be \$174,200 +/- 20%. The life-cycle cost is reported as the net present value (NPV) using a 4% discount factor as recommended by the OMB. At a volume of contaminated groundwater of 81,000 gallons and volume of contaminated saturated soil of 1330 cy³, the unit cost to remediate these media are \$2.15/gal and \$131/cy³, respectively.

The following assumptions were made for the cost estimate.

- The AS system will operate four times a day at 0.5 hour each time for a total operating time of two hours/day.
- The site is near ENVIROGEN's office and per diems are not needed.

Table 7. Cost Reporting for MTBE Remediation with Propane Biosparging (Entire Site).

1. Capital Costs	Cost (\$)
Mobilization/Demobilization	\$ 6,100.00
Planning/Preparation	\$ 12,000.00
Site Work	\$ 6,300.00
Equipment Enclosure	\$ --
Process Equipment	\$ --
Baseline Monitoring	\$ 2,600.00
Start-up and Testing	\$ 3,200.00
Installation	\$ 39,900.00
Engineering	\$ 14,500.00
Management Support	\$ 15,400.00
Sub-Total (\$)	\$100,000.00

Variable Costs	Per Year	PV at 4%
2. Operation and Maintenance		
Labor	\$24,540.00	\$46,135.20
Materials and Consumables	\$ 110.00	\$ 206.80
Utilities and Fuel	\$ 1,720.00	\$ 3,233.60
Equipment Cost	\$ 3,000.00	\$ 5,640.00
Performance Testing		
Other Direct Costs	\$ 5,270.00	\$ 9,907.60
		\$65,123.20

Variable Costs	Per Year	PV at 4%
3. Other Technology-Specific Costs		
Long-Term Monitoring	\$2,960.00	\$ 5,564.80
Regulatory/Institutional Oversight	\$1,600.00	\$ 3,008.00
Compliance Testing		
Soil Collection and Control	\$ 550.00	\$ 550.00 (CAPITAL COST)
Disposal of Residues		
		\$ 9,122.80

TOTAL TECHNOLOGY COST	\$171,246.00
ROUND	\$171,200.00
QUANTITY GROUNDWATER TREATED (GAL)	\$ 81,000.00
UNIT COST (PER GAL)	\$ 2.15
QUANTITY SOIL TREATED (CY)	\$ 1,330.00
UNIT COST (PER CY)	\$ 131.01

NOTE:

Total price for site remediation is based on two years of operation.
Present value based on 4% discount recommended by OMB.

- If a bacterial injection is needed, the additional cost is \$1,000 per event.
- The biostimulation system will be leased to the project.

5.1.3.3 Cost Estimate for Pump and Treat

The following assumptions are made for the installation and O&M of the pump and treat system.

- Two groundwater extraction wells installed to 10 ft. below groundwater with submersible pumps and controls.
- Monitoring wells installed to 10 ft. below groundwater.
- Estimated 150 ft. of piping to groundwater extraction wells installed below grade with conduit and wire to each pump from control panel at system enclosure.
- Groundwater treatment system in enclosure with two 1000 lb. liquid phase granular activated carbon (LPGAC) adsorbers in series with connecting piping, valves, meter, and discharge to sewer or surface water, AS blower, propane tank, piping, instrumentation and control panel.

The tasks for implementing the design, installation, and O&M of the system are as follows.

- *Design* — Design of system, preparation of application for Discharge to Groundwater Permit or Sewer Use Permit, one meeting.
- *Procurement and mobilization* — Procurement of equipment and materials, preparation for mobilization, and mobilization.
- *Installation* — Installation of groundwater extraction wells, monitoring wells, trenching, pipe installation, backfilling, surface restoration, connection to system, electrical connection, disposal of soils from trench.
- *Baseline monitoring* — Baseline monitoring of VOCs.
- *Start-up* — Start-up of system, three days of start-up surveillance and monitoring to maximize performance of the system, and letter report.
- *Monitoring* — Quarterly monitoring of VOCs. Weekly visits for system inspection and balancing.
- *Demobilization* — Disconnect and dismantle system, remove system from site.
- *Final Report* — Final letter report prepared and submitted to client.

A summary of the costs for the pump and treat system is presented in Table 8 with a breakdown for labor, pass through, equipment and sub contractors, and materials. The total cost is based on the time needed to remediate the groundwater to a typical cleanup objective (70 ppb) and estimated to be 10 years (based on experience from other sites, the use of pump and treat systems typically requires 10 to 30 years to attain cleanup objectives). Based on a ten year remediation, the total life-cycle cost for the project is estimated to be \$433,100 +/- 20%. The life-cycle cost is reported as the NPV using a 4% discount factor as recommended by OMB. At a volume of contaminated groundwater of 81,000 gallons and volume of contaminated saturated soil of 1330 yd³, the unit cost to remediate these media are \$5.35/gal and \$326/ yd³, respectively.

Table 8. Cost Reporting for MTBE Remediation with Pump and Treat.

1. Capital Costs	Cost (\$)
Mobilization/Demobilization	\$ 6,100.00
Planning/Preparation	\$ 12,000.00
Site Work	\$ 3,400.00
Equipment Enclosure	\$ --
Process Equipment	\$ --
Baseline Monitoring	\$ 2,400.00
Start-up and Testing	\$ 3,200.00
Installation	\$ 45,700.00
Engineering	\$ 14,500.00
Management Support	\$ 15,400.00
Sub-Total (\$)	\$102,700.00

Variable Costs	Per Year	PV at 4%
2. Operation and Maintenance		
Labor	\$24,540.00	\$199,019.40
Materials and Consumables	NA	
Utilities and Fuel	\$ 3,880.00	\$ 31,466.80
Equipment Cost	NA	
Performance Testing	NA	
Other Direct Costs	\$ 2,270.00	\$ 18,409.70
		\$248,895.90

Variable Costs	Per Year	PV at 4%
3. Other Technology-Specific Costs		
Long-Term Monitoring	\$2,960.00	\$24,005.60
Regulatory/Institutional Oversight	\$6,400.00	\$51,904.00
Compliance Testing	NA	
Soil Collection and Control	\$ 550.00	\$ 550.00 (CAPITAL COST)
Disposal of Residues	\$5,000.00	\$ 5,000.00 (CAPITAL COST)
		\$81,459.60

TOTAL TECHNOLOGY COST	\$433,055.50
ROUND	\$433,100.00
QUANTITY GROUNDWATER TREATED (GAL)	\$ 81,000.00
UNIT COST (PER GAL)	\$ 5.35
QUANTITY SOIL TREATED (CY)	\$ 1,330.00
UNIT COST (PER CY)	\$ 325.64

NOTE:

Total price for site remediation is based on 10 years of operation.

Present value based on 4% discount factor recommended by OMB.

The following assumptions were made for the cost estimate.

- The pump and treat system will operate continuously for 24 hours/day.
- The site is near ENVIROGEN's office and per diems are not needed.

5.2 COST ANALYSIS

The sensitivity of the cost to site-specific factors can be used to give guidance on factors that cause the costs to differ from each of the scenarios presented. The following factors have been selected for the sensitivity analyses.

- Impacted depth
- MTBE concentration
- Presence of co-contaminants
- Need for vapor recovery
- Radius of influence
- Groundwater velocity

The effect of these factors on the costs for each of the scenarios is discussed in the following sections.

5.2.1 Propane Biosparging

Our cost estimates suggest that the cost of applying propane biosparging to treat the entire site is only approximately \$4,000 more than applying the technology in a biobarrier design. The primary additional cost is for the installation of three additional sparging wells and approximately 125 feet of piping. Because of the similarity in the costs, and the fact that installation costs can vary by +/- 10% depending on location and site specific factors, the sensitivity analyses for the two technologies were combined. The greater cost (treating the entire site) was used for the analysis.

Impacted Depth – The depth of the contamination affects the depth of the AS/PIPs, VMPs, and monitoring wells, e.g., the deeper the contamination, the deeper the AS/PIPs, VMPs, and monitoring wells will have to be. This affects well and point installation time, and cost for well and point materials. The overall change in cost to the total budget is proportional to the change in the installation of the AS/PIPs, VMPs, and monitoring wells. Assuming a change in installation cost of 20% due to impacted depth, the incremental change to the total budget is +/- 1%.

MTBE Concentration – The MTBE concentration affects the duration of the remediation, e.g., the greater the MTBE concentration, the longer the remediation. The duration affects the time needed for operating and maintaining the system. For cost estimating purposes, a one year period is assumed for the change in duration to meet the cleanup objective. The effect on the budget is calculated using the annual O&M cost of \$33,000. Using the change in O&M cost of \$33,000, the change to the total budget is +/- 19%.

Co-Contaminants – The presence of co-contaminants affects the duration of the remediation, e.g., the greater the mass of co-contaminants, the longer the remediation. This assumes that the MTBE degrading bacteria are also degrading the co-contaminants and/or other bacteria are degrading the contaminants. More time is needed for the bacteria to degrade a greater mass of contamination. The

duration affects the time needed for operating and maintaining the system. For cost estimating purposes, a one year period is assumed for the change in duration to meet the cleanup objective. The effect on the budget is calculated using the annual O&M cost of \$33,000. Using the change in O&M cost of \$33,000, the change to the total budget is +/- 19%.

Vapor Recovery – Vapor recovery is typically used in cases where fugitive emissions could potentially present a risk to human health or the environment. Since the biosparging system uses AS with propane injection, there is a potential for fugitive emissions. However, monitoring soil gas and ambient air with a flame ionization detector at other sites showed that the vapor concentrations rarely exceeded the action levels, and when actions levels were exceeded, the monitor interfaced with the control panel to shut off the system. The use of vapor monitoring that is capable of a system shutdown eliminates the need and cost for a vapor recovery and treatment system. It is therefore assumed that vapor recovery is not needed and there is no change to the total budget from vapor recovery.

Radius of Influence – The radius of influence (ROI) of the wells affects the number of wells needed to remediate a given area. If the ROI is small, more wells are needed. Conversely, if the ROI is large, fewer wells are needed. The wells that are most affected by the ROI for the biosparging are the AS/PIPs. This affects installation time, and the cost for materials. The overall change in cost to the total budget is proportional to the change in the installation of the AS/PIPs. Assuming a change in installation cost of 20%, the incremental change to the total budget is +/- 2%.

Groundwater Velocity – The groundwater velocity through the source area affects the rate of transport of the contaminants through the affected area. Greater groundwater velocities would transport the contaminants through the affected area faster compared to slower velocities. At high groundwater velocities, the area would meet the cleanup objectives sooner from transport of the contaminants alone. At higher groundwater velocities, the remediation cost would decrease since the duration of the remediation would be shorter. Thus, at higher groundwater velocities, less time is needed to attain the cleanup objectives. These savings would be slightly off set by the increase in sparging and propane injection needed to maintain the necessary oxygen and propane concentration needed by the bacteria. The duration affects the time needed for operating and maintaining the system. For cost estimating purposes, a one year period is assumed for the change in duration to meet the cleanup objective. The effect on the budget is calculated using the annual O&M cost of \$33,000. Using the change in O&M cost of \$33,000, the change to the total budget is +/- 19%.

The effect of a change to each factor, and the overall effect on the total cost of the remediation, is presented in Table 9.

Table 9. Sensitivity Analysis for MTBE Remediation with Propane Biosparging (Biobarrier or Entire Site).

Scenario	Description	Total Technology Cost	Original Technology Cost	Difference (+/-)	% Increase (+/-)
1	Increase in Installation Cost by 10%	\$178,200	\$174,200	\$ 4,000	2.3
2	Increase in Installation Cost by 20%	\$185,000	\$174,200	\$10,800	6.2
3	Increase in Annual O&M Cost by 10%	\$181,800	\$174,200	\$ 7,600	4.4

5.2.2 Pump and Treat

Impacted Depth – The depth of the contamination affects the depth of the groundwater extraction wells and monitoring wells, e.g., the deeper the contamination, the deeper the groundwater extraction wells and monitoring wells will have to be. This affects well installation time, and cost for well materials. The overall change in cost to the total budget is proportional to the change in the installation of the wells. Assuming a change in installation cost of 20% due to impacted depth, the incremental change to the total budget is +/- 0.1%.

MTBE Concentration – The MTBE concentration affects the duration of the remediation, e.g., the greater the MTBE concentration, the longer the remediation. The duration affects the time needed for operating and maintaining the system. For cost estimating purposes, a one year period is assumed for the change in duration to meet the cleanup objective. The effect on the budget is calculated using the annual O&M cost of \$36,000. Using the change in O&M cost of \$33,000, the change to the total budget is +/- 6.9%.

Co-Contaminants – The presence of co-contaminants affects the duration of the remediation, e.g., the greater the mass of co-contaminants, the longer the remediation. This assumes that the MTBE degrading bacteria are also degrading the co-contaminants and/or other bacteria are degrading the contaminants. More time is needed for the bacteria to degrade a greater mass of contamination. The duration affects the time needed for operating and maintaining the system. For cost estimating purposes, a one year period is assumed for the change in duration to meet the cleanup objective. The effect on the budget is calculated using the annual O&M cost of \$36,000. Using the change in O&M cost of \$33,000, the change to the total budget is +/- 6.9%.

Vapor Recovery – Vapor recovery is typically used in cases where fugitive emissions could potentially present a risk to human health or the environment. Since the pump and treat system does not use air injection, there is very little, if any, potential for fugitive emissions. It is therefore assumed that vapor recovery is not needed and there is no change to the total budget from vapor recovery.

Radius of Influence – The radius of influence (ROI) of the wells affects the number of wells needed to remediate a given area. If the ROI is small, more wells are needed. Conversely, if the ROI is large, fewer wells are needed. The wells that are most affected by the ROI for pump and treat are the groundwater extraction wells. This affects installation time and the cost for materials. The overall change in cost to the total budget is proportional to the change in the installation of the wells. Assuming a change in installation cost of 20%, the incremental change to the budget is +/- 0.4%.

Groundwater Velocity – The groundwater velocity through the source area affects the rate of transport of the contaminants through the affected area. Greater groundwater velocities would transport the contaminants through the affected area faster compared to slower velocities. At high groundwater velocities, the area would meet the cleanup objectives sooner from transport of the contaminants alone. At higher groundwater velocities, the remediation cost would decrease since the duration of the remediation would be shorter. However, when pump and treat is used, groundwater velocity is not a factor since the groundwater is extracted from the area of concern. Thus, there is no significant effect on the remediation cost from groundwater velocity when pump and treat is used.

The effect of a change to each factor, and the overall effect on the total cost of the remediation, is presented in Table 10.

Table 10. Sensitivity Analysis for MTBE Remediation with Pump and Treat.

Scenario	Description	Total Technology Cost	Original Technology Cost	Difference (+/-)	% Increase (+/-)
1	Increase in Installation Cost by 10%	\$437,600	\$433,100	\$ 4,500	1.0
2	Increase in Installation Cost by 20%	\$442,200	\$433,100	\$ 9,100	2.1
3	Increase in Annual O&M Cost by 10%	\$453,000	\$433,100	\$19,900	4.6

5.3 COST COMPARISON OF TECHNOLOGIES

A comparison of the costs for propane biosparging vs. pump and treat show that propane biosparging is significantly more cost effective. This is primarily due to the time needed for operation of the system to attain the cleanup objective and the effect (increased number of monitoring events) on the cost of quarterly monitoring.

5.3.1 Effect of Matrix Characteristics

The following matrix characteristics could affect propane biosparging.

- Low pH (<5) of the saturated zone could adversely affect the growth of the propanotrophs. If the pH is <5, an alkaline solution will be needed to raise the pH to a more ideal range of 6 to 9.
- Low permeability of the saturated soils that would adversely affect the migration of the oxygen and propane throughout the contaminated area. Oxygen and propane are needed by the propanotrophs for the oxidation of MTBE.

The following matrix characteristics could affect pump and treat.

- Low permeability of the saturated soils that would adversely affect the extraction of groundwater for treatment.
- The presence of layers of soil with varying permeability that would cause greater groundwater extraction rates from areas of higher permeability. Thus, there may be soils where very little water is extracted for treatment, i.e., still contain contaminants of concern.

5.3.2 Issues that Affect Cost Savings

Geotechnical Evaluation of the Site – It is anticipated that a geotechnical evaluation of the site for both technologies would not be needed since these investigations are typically for the design of foundations for structures. Since neither of the technologies require permanent structures, geotechnical evaluations would not be required.

Requirements for Site Preparation, Utilities, Roads and Shelter – It is anticipated that very little, if any, site preparation will be required since the technologies require mobile or small temporary shelters for treatment system equipment.

Replacement Parts – The cost of replacement parts for the biosparging system is anticipated to be minimal. The items that could require replacement are the air compressor and motor. However, considering the estimated duration of the remediation (two years), the probability that the compressor and/or motor would fail is low. For the pump and treat system, the submersible pumps might need to be replaced every two to three years because of silting or motor burn out. However, the cost for submersible pumps is minimal at \$500 per pump.

Fire Protection – Since neither of these options requires permanent structures, fire protection would not be needed with the exception of hand held extinguishers maintained on site. Safety considerations regarding propane injection were discussed earlier.

Residual Waste Treatment/Disposal – There will be no residual wastes generated from the operation of the biosparging system. The installation of the system will generate waste concrete and/or macadam from the cutting and excavation of the surface for the piping trenches. There will also be some excess soil for disposal from the piping trenches. Residual wastes generated from the operation of the pump and treat system will be activated carbon from treatment of the extracted groundwater. The installation of the pump and treat system will also generate waste concrete and/or macadam from the cutting and excavation of the surface for the piping trenches. There will also be some excess soil for disposal from the piping trenches. Since the pump and treat system requires the disposal of activated carbon, the operation of the pump and treat system is less cost effective than the biosparging with regard to residual waste.

Permits – The biosparging system could require a permit from the regulatory agency. The permit could include required ambient air monitoring, soil gas monitoring, monitoring frequency, operating conditions, and reporting. The pump and treat system will most likely require a National Pollutant Discharge Elimination System (NPDES) permit for the discharge of the treated water to a surface water body. The permit will include required operating conditions, monitoring, and reporting. Both systems typically require building permits that focus on excavation, electrical installation, and plumbing. Since the preparation of a NPDES permit requires about 80 hours by an environmental engineer, the permitting for the pump and treat system is more costly than the biosparging system.

Reduction of Worker Exposure to Hazardous Materials – The installation of either of the systems will require trenching for piping, thus, there could be some exposure to VOCs depending upon the concentration of the VOCs in the soil trench. Since both systems will require trenching, there is potential to VOC exposure during the installation of both systems, thus, neither system has a cost advantage over the other with respect to the level of personnel protection that will be needed.

6.0 IMPLEMENTATION ISSUES

6.1 COST OBSERVATIONS

Much of the cost of this demonstration was related to work plan preparation, design and preparation for system installation, management support, and performance testing and analysis. Areas for reducing costs in future applications include reduced sampling events and reducing the analysis required at each sampling event. For example, full geochemical analysis may not be required at every sampling event. Rather, most sampling events would include limited analysis, including MTBE, TBA, and collection of field parameters. Overall costs, including planning, design, management and management support, among others, would be expected to be reduced as a result of experience gained from this demonstration.

The cost of applying propane biosparging was significantly less than pump and treat remediation. The estimated carbon usage for the pump and treat system were based on carbon vendor claims. In our experience with MTBE remediation these estimates may grossly underestimate actual carbon usage.

Our cost analyses demonstrated that the cost of applying propane biosparging to treat the entire hypothetical site is only approximately \$4000 more than applying the technology in a biobarrier design. The primary additional cost is for the installation of three additional sparging wells and approximately 125 feet of piping. An advantage of the “entire site” approach is that one can potentially remediate the site more quickly than if a biobarrier is applied. Remediation by the biobarrier requires that the groundwater flows through the barrier and the site is flushed by the moving water. Actual treatment times, therefore, are controlled significantly by groundwater flow rates. At some sites, actual remediation times with the biobarrier may be much longer than estimated in this analysis. Thus overall treatment costs could be greater because of the extended monitoring and O&M costs.

6.2 PERFORMANCE OBSERVATIONS

For this demonstration, the goal of the treatment process was to reduce MTBE and TBA concentrations down gradient of the test plot to <5 µg/L, which is the level at which MCLs are expected to be set in some states. The U.S. EPA currently recommends 20 to 40 µg/L as the Health Advisory level for drinking water (U.S. EPA, 1998). The California Department of Environmental Health Services (DHS) has recently established a primary maximum contaminant level (MCL) for MTBE of 13 µg/L to protect public health and a secondary MCL of 5 µg/L to prevent taste and odor problems in groundwater (California Department of Environmental Health Services, 2002).

MTBE concentrations decreased in both the test and control plots during the demonstration. However, MTBE concentrations were reduced to less than 5 µg/L in only 3 of the 30 monitoring wells in the test plot and in none of the wells in the control plot. MTBE concentrations were reduced to less than 13 µg/L (the CA primary MCL) in three wells in each of the plots. MTBE concentrations were reduced to less than 40 µg/L (the high end of the EPA-recommended Health Advisory level) in eight of the wells in the test plot and in seven of the wells in the control plot.

6.3 SCALE-UP

The cost for scale-up would be affected by the following.

- *Aerial extent of the contamination* — The greater the aerial extent of contamination, the greater the number of injection and monitoring points, e.g., increased drilling and material cost.
- *Vertical extent of the contamination* — The greater the vertical extent of contamination, deeper injection and monitoring points will be needed, e.g., increased drilling and material cost.
- *Initial concentration of contaminants of concern* — The greater the initial concentration of the contaminants of concern, the longer the duration of the remediation, e.g., higher O&M costs.
- *Subsurface soil type* — The type of soil affects the costs for injection and monitoring point installation, e.g., lower costs for sands, silts, and clays since hollow stem auger or geoprobe can be used. Higher costs for bedrock since mud rotary or air rotary drilling must be used.
- *Variations in subsurface soil* — If there are layers of soil with varied permeabilities, dual-level or tri-level injection and monitoring may be needed. This increases drilling and material costs.
- *Selection of equipment* — If an air sparge blower is selected over oxygen cylinders as the method to supply oxygen, there will be increased costs for equipment, O&M, and utilities.
- *Surface conditions and type of pavement* — The type of surface to be cut, excavated, disposed, and restored for underground piping affects the installation cost, e.g., the thicker the surface, the greater the cutting, excavation, disposal, and restoration cost.
- *Location of underground utilities* — The location of the underground utilities affects installation costs if utilities interfere with the installation of the system, or utilities need relocation.
- *Location of above-ground structures* — the location of the above-ground structures affects installation costs if structures interfere with the installation of the system (affect the movement and operation of excavation equipment and/or drill rigs. Additionally, the location of above ground structure could necessitate rerouting field piping around the structures, thus, lengthening the trenching and piping.

Since the equipment and materials needed for the biosparging system are commercially available, scale-up constraints are not anticipated.

6.4 OTHER SIGNIFICANT OBSERVATIONS

As discussed in Section 5, a major factor which can affect implementation of the technology is the low pH (<5) in the groundwater that would adversely affect the growth of the propanotrophs. A solution to this potential factor is the injection of an alkaline solution to raise the pH to a more ideal range of 6 to 9.

A second factor which can affect the implementation of the technology could be low permeability of the saturated soils that would adversely affect the migration of the oxygen and propane throughout the contaminated area. Oxygen and propane are needed by the propanotrophs for the oxidation of MTBE. A solution to this potential problem is decreasing the permeability by pneumatic or hydraulic fracturing. Pneumatic fracturing (PF) uses the injection of pressurized air

(up to 175 psi) in to the formation that causes the formation of fractures or the widening of fractures in the formation. Typically, the contaminants of concern are in the fractures, thus, widening existing fractures will increase the flow of groundwater with oxygen and propane through the fractures to increase the biodegradation of the contaminants. Hydraulic fracturing is similar to PF with the exception that water is used and at pressures as high as 2000 psi.

Technical questions related to the use of biosparging for the degradation of MTBE should be directed to Rob Steffan, Ph.D., of ENVIROGEN (see Section 8).

6.5 LESSONS LEARNED

1. **Propane biosparging can be applied safely and inexpensively.** This project demonstrated that propane biosparging can be safely and economically applied at the field scale to promote in situ degradation of MTBE. Application of the technology resulted in no measurable fugitive emissions of propane, and in situ biodegradation maintained propane levels near or below its detection limit in groundwater. Because of low propane emissions, the technology should not require secondary containment systems (e.g., soil vapor extraction) in most cases. Thus, it may be cost effective to incorporate propane biosparging equipment into MTBE remediation designs, even at sites where MTBE biodegradation by indigenous organisms is suspected. If indigenous bacteria prove to be inefficient or ineffective at remediating the site, propane can be injected to enhance activity at minimal additional cost.
2. **System designs must ensure delivery of sufficient oxygen.** This study demonstrated that most of the active MTBE degradation that occurred in both plots occurred near the oxygen injection points. This limit of degradation activity was probably caused by consumption of the oxygen added to the plot. Oxygen was likely consumed by both geochemical oxygen sinks and biological activity. Because of the process monitoring and technology validation procedures of both ENVIROGEN and the U.S. EPA, we elected not to increase gas flows into the site during this demonstration. To reach even lower MTBE levels, however, either additional rows of oxygen injection points should be used, or oxygen loading rates should be increased. Thus, for full-scale application, the treatment zone may need to be expanded if the MTBE concentrations are high, if other oxygen demanding compounds are present, and/or if groundwater flow is such that sufficient oxygen can not be added by a single row of injection points. Alternatively, other systems designs (e.g., trenches, recirculating wells, etc.) may be more appropriate for some sites.
3. **Indigenous microbes in some aquifers can efficiently degrade MTBE if supplied the appropriate nutrient or oxygen.** An important lesson from this work is that MTBE degradation potential can exist even in aquifers with large and expanding MTBE plumes. In some cases, simply adding oxygen can enhance MTBE degradation in these aquifers. Thus, relatively short duration biosparging tests may be recommended for sites where natural degradation of MTBE is expected. Alternately, treatment systems can be designed for flexibility. If they are designed so that propane can be added after installation, they can be operated initially without propane, and propane can be added only if MTBE degradation is not observed in its absence.

4. **Propane biosparging can support the growth and activity of indigenous or added propane oxidizing bacteria.** Injection of propane supported the growth and apparent MTBE degrading ability of propane oxidizing bacteria. The demonstration was initiated by adding 17 L of the propane oxidizing bacterium *Rhodococcus ruber* ENV425, and little propane was measured down gradient of the bacterial injection points. Thus, it is likely the added organisms degraded the propane or, at least contributed to its degradation. Very little propane degradation was observed in microcosms that were not seeded with ENV425. Furthermore, at the end of the study, propane degraders could not be isolated from the Control plot, but they were readily isolated from the Test plot. Many of the isolated propanotrophs appeared to be different from ENV425 in colony morphology and color. Thus, it is likely that indigenous propane/MTBE degrading microbes grew in the aquifer during the course of the demonstration.

7.0 REFERENCES

1. Brockman, F. J., W. Payne, D. J. Workman, A. Soong, S. Manley and T. C. Hazen. 1995. Effect of gaseous nitrogen and phosphorus injection on in situ bioremediation of a trichloroethylenecontaminated site. *J Haz. Mats.* 41:287-298.
2. California Department of Health Services. 2002. Drinking Water Monitoring for MTBE. <http://www.dhs.ca.gov/ps/ddwem/chemicals/MTBE/mtbeindex.htm>. October 2, 2002.
3. Environmental Security Technology Certification Program (ESTCP). 2000. Cost and Performance Report, Guidance for Cleanup, Site Characterization and UXO Projects. June 2000.
4. ENVIROGEN. Technology Demonstration Plan. In-Situ Remediation of MTBE Contaminated Aquifers Using Propane Biostimulation. October 17, 2000.
5. ENVIROGEN. Technology Demonstration Draft Final Report. In-Situ Remediation of MTBE Contaminated Aquifers Using Propane Biostimulation. September 13, 2002.
6. Hazen, T.C. et al. 1994. Summary of in situ bioremediation demonstration (methane biostimulation) via horizontal wells at the Savannah River Site Integrated Demonstration Project. In: *In Situ Remediation: Scientific Basis for Current and Future Technologies*. Battelle Press, Richland. WA. pp. 137-150.
7. Hopkins, G. D., L. Semprini, and P. L. McCarty. 1993. Microcosm and in situ field studies of enhanced biotransformation of trichloroethylene by phenol-utilizing microorganisms. *Appl. Environ. Microbiol.* 59:2277-2285.
8. Hopkins, Gary D. and Perry L. McCarty. 1995. Field evaluation of in situ aerobic cometabolism of trichloroethylene and three dichloroethylene isomers using phenol and toluene as the primary substrates. *Environ. Sci. Technol.* 29:1628-1637.
9. Keller, A. A., et al., 1998. Cost and performance evaluation of treatment technologies for MTBE-contaminated water. <http://tsrtp.ucdavis.edu/mtberpt/homepage.html>.
10. Leeson, A., P.C. Johnson, R.L. Johnson, R.E. Hinchee, and D.B. McWhorter. 1999. Air Sparging Paradigm Draft. Batelle, Columbus, Ohio.
11. Lombard, K. H., J. W. Borthen and T.C. Hazen. 1994. The design and management of system components for in situ bioremediation of chlorinated hydrocarbons at the Savannah River Site. In: "Air Sparging for Site Remediation". Eds. Hinchee, et al., Lewis Publishers, Boca Raton. pp. 81-96.
12. McCarty, Perry L., Mark N. Goltz, Garry D. Hopkins, Mark E. Dolan, Jason P. Allan, Brett T. Kawakami, and T. J. Carrothers. 1998. Full-scale evaluation of in situ cometabolic degradation of trichloroethylene in groundwater through toluene injection. *Environ. Sci. Technol.* 32:88-100.

13. MTBE Research Partnership. 1998. Treatment Technologies for Removal of Methyl Tertiary Butyl Ether (MTBE) from Drinking Water. December 1998.
14. Semprini, L., G.D. Hopkins, and P.L. McCarty. 1994. A field and modeling comparison of in situ transformation of trichloroethylene by methane utilizers and phenol utilizers in: "Bioremediation of Chlorinated and Polycyclic Aromatic Hydrocarbon Compounds". Eds. Hinchee, et al., Lewis Publishers, Boca Raton. pp. 248-254.
15. Semprini, Lewis and Perry L. McCarty. 1992. Comparison between model simulations and field results for in-situ bioremediation of chlorinated aliphatics: Part 2. Cometabolic transformations. *Ground Water* 30:37-44.
16. Semprini, Lewis and Perry L. McCarty. 1991. Comparison between model simulations and field results for in-situ bioremediation of chlorinated aliphatics: Part 1. Biostimulation of methanotrophic bacteria. *Ground Water* 29:365-374.
17. Steffan, R. J., K. McClay, S. Vainberg, C. W. Condee, and D. Zhang. 1997. Biodegradation of the gasoline oxygenates methyl tert-butyl ether, ethyl tert-butyl ether, and tert-amyl ether by propane-oxidizing bacteria. *Appl. Environ. Microbiol.* 63:4216-4222.
18. Tovanabootr, Adisorn, Mark E. Dolan, Lewis Semprini, Victor S. Magar, Andrea Leeson, and Alison Lightner. 2000. Cometabolic air sparging field demonstration with propane to remediate a chloroethene and chloroethane co-contaminated aquifer, p. 67-74. In G. B. Wickramanayake and A. R. Gavaskar (eds.). *Physical and Thermal Technologies: Remediation of Chlorinated and Recalcitrant Compounds*. Battelle Press. Columbus, OH.
19. United States Environmental Protection Agency. 1998. MTBE Fact Sheet #2 – Remediation of MTBE Contaminated Soil and Groundwater. EPA 510-F-97-015. Office of Solid Waste and Emergency Response, Washington, DC.

APPENDIX A

POINTS OF CONTACT

Point of Contact (Name)	Organization (Name & Address)	Phone/Fax/E-mail	Role in Project
Dr. Robert Steffan	ENVIROGEN 4100 Quakerbridge Road Lawrenceville, NJ 08648	(609) 936-9300 (609) 936-9221 Steffan@envirogen.com	Principal Investigator
Dr. Yassar Farhan	ENVIROGEN 4100 Quakerbridge Road Lawrenceville, NJ 08648	(609) 936-9300 (609) 936-9221 Farhan@envirogen.com	Project Manager
Dr. Todd Webster	ENVIROGEN 5111 LaJolla Blvd, #3 San Diego, CA 92109	(858) 483-8684 (858) 483-8684 tswebs@cox.net	Project Manager
Martha D. Atkins	ENVIROGEN 4100 Quakerbridge Road Lawrenceville, NJ 08648	(609) 936-9300 (609) 936-9221 Arkins@envirogen.com	Assistant Project Manager
Gail Pringle/ Dorothy Cannon/ Kathy Greene	NFESC Code 411 1100 23rd Avenue Port Hueneme, CA 93043-4370	(805) 982-1614/5284 (805) 982-4304 Cannondl@nfesc.navy.mil Greeneka@nfesc.navy.mil	NFESC Project Manager
	U.S. EPA - ORD Subsurface Protection & Remediation Division 919 Kerr Research Drive Ada, OK 78820		



ESTCP Program Office

**901 North Stuart Street
Suite 303
Arlington, Virginia 22203**

**(703) 696-2117 (Phone)
(703) 696-2114 (Fax)**

**e-mail: estcp@estcp.org
www.estcp.org**