

ESTCP Cost and Performance Report

(ER-201168)



Demonstration of Regenerable, Large-Scale Ion Exchange System Using WBA Resin in Rialto, CA (Drinking Water Treatment - Pilot Scale)

August 2008



ENVIRONMENTAL SECURITY
TECHNOLOGY CERTIFICATION PROGRAM

U.S. Department of Defense

Report Documentation Page

Form Approved
OMB No. 0704-0188

Public reporting burden for the collection of information is estimated to average 1 hour per response, including the time for reviewing instructions, searching existing data sources, gathering and maintaining the data needed, and completing and reviewing the collection of information. Send comments regarding this burden estimate or any other aspect of this collection of information, including suggestions for reducing this burden, to Washington Headquarters Services, Directorate for Information Operations and Reports, 1215 Jefferson Davis Highway, Suite 1204, Arlington VA 22202-4302. Respondents should be aware that notwithstanding any other provision of law, no person shall be subject to a penalty for failing to comply with a collection of information if it does not display a currently valid OMB control number.

1. REPORT DATE AUG 2008		2. REPORT TYPE		3. DATES COVERED 00-00-2008 to 00-00-2008	
4. TITLE AND SUBTITLE Demonstration of Regenerable, Large-Scale Ion Exchange System Using WBA Resin in Rialto, CA (Drinking Water Treatment - Pilot Scale)				5a. CONTRACT NUMBER	
				5b. GRANT NUMBER	
				5c. PROGRAM ELEMENT NUMBER	
6. AUTHOR(S)				5d. PROJECT NUMBER	
				5e. TASK NUMBER	
				5f. WORK UNIT NUMBER	
7. PERFORMING ORGANIZATION NAME(S) AND ADDRESS(ES) Environmental Security Technology Certification Program (ESTCP), 4800 Mark Center Drive, Suite 17D08, Alexandria, VA, 22350-3605				8. PERFORMING ORGANIZATION REPORT NUMBER	
9. SPONSORING/MONITORING AGENCY NAME(S) AND ADDRESS(ES)				10. SPONSOR/MONITOR'S ACRONYM(S)	
				11. SPONSOR/MONITOR'S REPORT NUMBER(S)	
12. DISTRIBUTION/AVAILABILITY STATEMENT Approved for public release; distribution unlimited					
13. SUPPLEMENTARY NOTES					
14. ABSTRACT					
15. SUBJECT TERMS					
16. SECURITY CLASSIFICATION OF:			17. LIMITATION OF ABSTRACT	18. NUMBER OF PAGES	19a. NAME OF RESPONSIBLE PERSON
a. REPORT unclassified	b. ABSTRACT unclassified	c. THIS PAGE unclassified			

COST & PERFORMANCE REPORT

Project: ER-0312

TABLE OF CONTENTS

	Page
1.0 EXECUTIVE SUMMARY	1
1.1 BACKGROUND—DEMONSTRATION AT REDSTONE ARSENAL	1
1.2 OBJECTIVES OF DEMONSTRATION	1
1.3 REGULATORY DRIVERS	1
1.4 SUMMARY OF DEMONSTRATION RESULTS	2
1.5 STAKEHOLDER/END-USER ISSUES	2
2.0 TECHNOLOGY DESCRIPTION	5
2.1 TECHNOLOGY DEVELOPMENT AND APPLICATION	5
2.2 PROCESS DESCRIPTION	5
2.3 PREVIOUS TESTING OF THE TECHNOLOGY	6
2.4 ADVANTAGES AND LIMITATIONS OF THE TECHNOLOGY	6
3.0 DEMONSTRATION DESIGN	9
3.1 PERFORMANCE OBJECTIVES	9
3.2 SELECTING TEST SITES	10
3.3 TEST SITE/FACILITY HISTORY/CHARACTERISTICS	10
3.4 PHYSICAL SETUP AND OPERATION	10
3.5 SAMPLING/MONITORING PROCEDURES	12
3.6 ANALYTICAL PROCEDURES	14
4.0 PERFORMANCE ASSESSMENT	17
4.1 PERFORMANCE DATA	17
4.1.1 Perchlorate	17
4.1.2 Langelier Saturation Index	18
4.1.3 Nitrosamines	18
4.1.4 Scavenger Treatment of Spent Regenerant	19
4.2 PERFORMANCE CRITERIA	19
4.3 DATA ASSESSMENT	21
4.4 TECHNOLOGY COMPARISON	22
5.0 COST ASSESSMENT	25
5.1 COST REPORTING	25
5.1.1 Capital Cost	25
5.1.1.1 Process Configuration	25
5.1.1.2 Design and Operating Basis	27
5.1.1.3 Major Equipment	28
5.1.2 Operating and Maintenance Cost	29
5.1.2.1 O&M Cost Components	29

TABLE OF CONTENTS (continued)

	Page
5.1.2.2 O&M Cost Basis	30
5.1.3 Economy of Scale	31
5.2 COST ANALYSIS.....	32
5.2.1 Major Cost Drivers	32
5.2.1.1 Groundwater Alkalinity	32
5.2.1.2 Perchlorate Concentration.....	32
5.2.1.3 Treated Water Alkalinity	32
5.2.1.4 Resin Regeneration Cost.....	33
5.2.1.5 WBA Resin Cost.....	33
5.3 COST COMPARISON	33
6.0 IMPLEMENTATION ISSUES	35
6.1 COST OBSERVATIONS.....	35
6.2 PERFORMANCE OBSERVATIONS.....	35
6.3 SCALE-UP	35
6.4 OTHER SIGNIFICANT OBSERVATIONS.....	36
6.5 LESSONS LEARNED.....	36
6.5.1 Process Operations.....	36
6.5.2 Regulatory Lessons.....	37
6.6 END-USER ISSUES	37
6.7 APPROACH TO REGULATORY COMPLIANCE AND ACCEPTANCE.....	38
7.0 REFERENCES	39
APPENDIX A POINTS OF CONTACT.....	A-1

LIST OF FIGURES

	Page
Figure 1. WBA Resin Chemistry	5
Figure 2. Demonstration Process.....	6
Figure 3. Sampling Locations	12
Figure 4. Process Configuration for Capital and O&M Cost Analyses	25
Figure 5. Regeneration Operations.....	26
Figure 6. Protonation Operations	27

LIST OF TABLES

	Page
Table 1.	Performance Objectives 9
Table 2.	Duration of Each Test Period..... 11
Table 3.	Sampling Summary for ESTCP Pilot Demonstration..... 13
Table 4.	Sampling Summary for Regeneration and Residual Treatments..... 14
Table 5.	Analytical Procedures Used During Demonstration..... 15
Table 6.	Perchlorate Data Summary Analyzed by ARA and Certified Laboratories 17
Table 7.	General Physical Data and LSI Value 18
Table 8.	Nitrosamine Data Summary..... 18
Table 9.	Anions in Spent Regenerant and the Scavenged Regenerant 19
Table 10.	Expected Performance and Performance Confirmation Methods 20
Table 11.	Demonstration Assessment..... 21
Table 12.	Performance Comparison WBA and SBA Systems 22
Table 13.	Summary of Design and Operating Bases 28
Table 14.	Type and Quantity of WBA Equipment and 2007 Budgetary Cost Estimates 28
Table 15.	O&M Cost Basis 30
Table 16.	Cost Summary..... 31
Table 17.	Capital and Operating Costs for a 4,000 gpm Treatment System..... 32
Table 18.	Present Worth Cost Comparison for Perchlorate Removal by Various Ion Exchange Technologies 34

ACRONYMS AND ABBREVIATIONS

A&E	architecture and engineering
AF	acre foot
ARA	Applied Research Associates, Inc.
BPOU	Baldwin Park Operable Unit
BV	bed volumes
BV/hr	bed volumes per hour
CaCO ₃	calcium carbonate
ClO ₄ ⁻	perchlorate
CDPH	California Department of Public Health Services
CSTR	continuously stirred tank reactor
DoD	Department of Defense
DWEL	drinking water equivalent level
DWSP	Drinking Water Supply Permit
EPA	Environmental Protection Agency
ESTCP	Environmental Security Technology Certification Program
gpm	gallons per minute
gw	groundwater
HASP	Health and Safety Plan
HCl	hydrochloric acid
HDPE	high density polyethylene
H ₂ SO ₄	sulfuric acid
IC	ion chromatography
IC/MS	ion chromatography/mass spectrometry
IC-MS/MS	ion chromatography-tandem mass spectrometry
ISEP	ion separation
L	liters
LC-MS/MS	liquid chromatography-quadruple spectrometry
LSI	langelier saturation index
MCL	maximum contaminant level
NaOH	sodium hydroxide
NASA	National Aeronautics and Space Administration
NDBA	N-nitrosodi-n-butylamine
NDEA	N-nitrosodiethylamine
NDMA	N-nitrosodimethylamine
NDPA	N-nitrosodi-n-propylamine

ACRONYMS AND ABBREVIATIONS (continued)

NDPhA	N-nitrosodiphenylamine
NELAP	National Environmental Laboratory Accreditation Program
NMEA	N-nitrosomethylethylamine
NMOR	N-nitrosomorpholine
NPIP	N-nitrosopiperidine
NPYR	N-nitrosopyrrolidine
NSF	National Sanitation Foundation
O&M	operations and maintenance
OSHA	Occupational Safety and Health Administration
ppb	parts per billion
ppm	parts per million
ppt	parts per trillion
psig	pounds per square inch, gauge
QA	quality assurance
QA/QC	quality assurance/quality control
QAPP	Quality Assurance Project Plan
RfD	reference dose
RL	reporting limit
SBA	strong base anion
TDS	total dissolved solids
TS/TDS	total solids/total dissolved solids
VOC	Volatile Organic Carbon
WBA	Weak Base Anion

ACKNOWLEDGEMENTS

The success of this demonstration was due in part to the coordination and assistance of several individuals from many organizations. Special appreciation is extended to Dr. Andrea Leeson, Ms. Kelly DeFillipo, Ms. Eve Carey, Ms. Deanne Rider, and Mr. Phillip Exum of the Program Office of the Environmental Security Technology Certification Program (ESTCP) for their guidance and support; Mr. Bryan Harre of the Naval Facilities Engineering Service Center (NAVFAC ESC) for acting as the contracting officer representative; Ms. Heather Collins and Mr. Sean McCarthy of the California Department of Public Health Services (CDPH), Drinking Water Field Operations Branch, for assistance with developing a comprehensive sampling and analysis plan; Mr. Frank LoGuidice of San Gabriel Valley Water Company and Mr. Chris Diggs of Fontana Water Company for hosting and coordinating site access at well site F17; Mr. Mick Miner and Mr. Mario Velarde of Fontana Water Company for assistance in site preparation, coordination of peripheral equipment operation, providing historical analytical data, and demobilization; and Ms. Fiela Gutierrez for on-site support with sampling and system operation.

Technical material contained in this report has been approved for public release.

This page left blank intentionally.

1.0 EXECUTIVE SUMMARY

1.1 BACKGROUND—DEMONSTRATION AT REDSTONE ARSENAL

In 2005, the Environmental Security Technology Certification Program (ESTCP) funded Applied Research Associates, Inc (ARA) to demonstrate a regenerable, ion exchange technology, codeveloped with The Purolite Company, using weak base anion (WBA) resin (D-4170) in a groundwater remediation application. The demonstration was conducted at Redstone Arsenal, located near Huntsville, Alabama. Well RS498, a 6-inch extraction well, was selected as the groundwater source for the demonstration. Anion concentrations of the well were as follows: 1,500 to 2,200 parts per billion (ppb) perchlorate (ClO_4^-); 4 parts per million (ppm) nitrate; 3 ppm sulfate; 4 ppm chloride; and 190 ppm bicarbonate. Trichloroethene was also present in the groundwater at 3,100 ppb. During the 15-week demonstration, the process successfully removed perchlorate to below the method detection limit (4 ppb) using Environmental Protection Agency (EPA) Method 314.0. Regeneration was effectively and efficiently accomplished resulting in less than 0.05% spent regenerant volume, based on the water treated. The spent regenerant solution consisted of a relatively safe caustic solution that could be treated for perchlorate by scavenging, using a strong base anion (SBA) resin or by biodegrading after pH adjustment.

1.2 OBJECTIVES OF DEMONSTRATION

Based on the successful demonstration at Redstone Arsenal (groundwater remediation-pilot scale), ESTCP funded a follow-on demonstration of the WBA ion exchange technology for a drinking water application. The demonstration had the following objectives: 1) demonstrate complete perchlorate removal, 2) demonstrate efficient and complete WBA resin regeneration, 3) demonstrate a “zero-discharge” perchlorate scavenger process, and 4) produce treated water that meets all drinking water quality guidelines. The drinking water treatment-pilot scale demonstration was conducted at Plant F17 in Fontana, California. Well F17-C water contained 8 ppb perchlorate; 11 ppm chloride; 31 ppm nitrate; 14 ppm sulfate; and 150 ppm bicarbonate.

The ion exchange pilot treatment system used during the demonstration at Redstone Arsenal was modified for use in this drinking water demonstration. The entire system was housed in an 8-ft by 20-ft enclosed trailer that provided breakered power, climate control, and protection from the elements while in the field. Ion exchange columns were prepared at the ARA Panama City Research Facility using Purolite D-4170 resin from the same batch of resin used in the demonstration at Redstone Arsenal.

1.3 REGULATORY DRIVERS

The Department of Defense (DoD) has used ClO_4^- as an oxidizer in ordnance items and rocket motors for over half a century. This very water soluble and environmentally persistent compound now contaminates drinking water for tens of millions of people in the United States. In 2002, the EPA released a provisional perchlorate oral reference dose (RfD), which translated into a drinking water equivalent level (DWEL) of 1 ppb. This DWEL was increased to 24.5 ppb following the release of a report by the National Academy of Sciences in 2005.

As a result of EPA establishing a RfD for perchlorate having a DWEL of 24.5 ppb, the DoD issued a policy letter in January 2006 that establishes 24 ppb as the “level of concern for managing perchlorate.” The letter further states that, “Once established, DoD will comply with applicable state or federal promulgated standards whichever is more stringent.” In California, the proposed maximum contaminant level (MCL) for perchlorate is 6 ppb. The cost for DoD to achieve compliance with this drinking water limit could be billions of dollars.

1.4 SUMMARY OF DEMONSTRATION RESULTS

Six test periods were conducted during this demonstration. The minimum treatment rate was 24 bed volumes per hour (BV/hr) or 3 gallons per minute (gpm)/ft³ (a surface loading rate of 9.7 gpm/ft²). Four test periods were breakthrough tests (1, 2, 5, and 6). During regeneration of the spent column, the lag column remained on line and treated water in a single column. The remaining two test periods (3 and 4) were short-cycle tests. In short-cycle tests, columns were regenerated after approximately one week on line and before breakthrough. These short-cycle tests were conducted to maximize the number of regenerations per column and minimize the duration of the demonstration. The short-cycle tests were also used to evaluate perchlorate removal efficiency at a higher specific flow rate of 4 gpm/ft³ (a surface loading rate of 12.9 gpm/ft²). Regeneration of spent resin and treatment of the spent regenerating solution using the zero-discharge scavenger process were conducted on site.

The treatment capacity determined from this demonstration was 9,700 bed volumes (BV). The treated water was below the method report limit for perchlorate (<0.10 ppb) using ion chromatography-tandem mass spectrometry (IC-MS/MS). Nitrosamines were analyzed using EPA Method 521. N-nitrosodimethylamine (NDMA) was 2.6 parts per trillion (ppt) with a detection limit of 2 ppt. All other nitrosamines analyzed (including N-nitrosodiethylamine [NDEA], N-nitrosodi-n-butylamine [NDBA], N-nitrosodi-n-propylamine [NDPA], N-nitrosomethylethylamine [NMEA], N-nitrosomorpholine [NMOR], N-nitrosopiperidine [NPIP], and N-nitrosopyrrolidine [NPYR]) were below the detection limit. A “dial-in” capability for controlling residual alkalinity of the treated water in the post-treatment process was demonstrated by varying the pH and using a combination of air/membrane stripping and calcite contacting. Treated water had a Langelier Saturation Index (LSI) near zero, which indicated that it had neither corrosive nor scaling tendencies. Five resin regenerations were accomplished using three BVs of regenerant solution, or approximately 0.03% of the treated water. The spent regenerating solution was successfully treated using the zero-discharge scavenger resin approach to remove perchlorate to below method reporting limits (RL).

1.5 STAKEHOLDER/END-USER ISSUES

End users for this technology include DoD facilities, formerly-used defense sites, and municipal drinking water supplies that have been contaminated with perchlorate. In addition to drinking water applications, the technology can be used by the DoD for pump-and-treat perchlorate remediation and to facilitate remediation of co-contaminants (such as volatile organic compounds [VOC]) by enabling the removal of perchlorate before discharge or re-injection. The technology can also be applied to the treatment of wastewater generated by munitions manufacturing or demilitarization operations.

Implementation of this technology is straightforward. Commercial, large-scale, ion exchange equipment for WBA resin technology exists. Pretreatment and post treatment are pH-controlled unit operations that are straightforward to design and engineer. Stripping tower design and engineering for CO₂ stripping is straightforward. Treatment of residuals by a scavenger ion exchange process is a proven technology. All processes operate at ambient temperature and low pressure (<30 pounds per square inch, gauge [psig]) and, therefore, present no unique engineering challenges or hazards.

The regenerable nature of this ion exchange technology is by definition more complex than single-use resin technology, will require use of regeneration chemicals on site, and will require an operator. Therefore, the issues of primary concern for user acceptance are 1) the perception of operational complexity, 2) the need for acid and caustic on site, and 3) the need for a part-time operator. However, treatment systems can be designed to operate with little operator oversight. For instance, regeneration cycles can be automatically initiated and executed. End-user concerns may be further offset by applications where water is highly contaminated, where regenerable ion exchange technologies are already in use, or where co-contaminants, such as nitrate, arsenic, or chromium, create the need for a regenerable ion exchange process.

The WBA resin technology overcomes issues typically associated with regenerable ion exchange processes by greatly reducing the volume of spent regenerating solution produced, which permits use of the zero-discharge perchlorate scavenging process and results in lower operating and maintenance (O&M) costs. Use of the WBA resin ion exchange process for treating perchlorate has proven efficient and economical, resulting in a 75% savings over current regenerable resin technology such as the ion separation (ISEP) process and up to a 50% savings over single-use resin processes. Treatment cost using the WBA resin process is less than \$100/AF. Groundwater alkalinity, sulfate and nitrate concentration, and the required treated water alkalinity will affect performance and cost, as is the case for any ion exchange process. However, the cost advantage of the WBA regenerable process over non-regenerable, single-use processes becomes much more pronounced as the concentration of perchlorate contamination increases.

This page left blank intentionally.

2.0 TECHNOLOGY DESCRIPTION

2.1 TECHNOLOGY DEVELOPMENT AND APPLICATION

Ion exchange technology using weak base anion (WBA) exchange resin was developed under ESTCP Project ER-0312 and successfully demonstrated in a groundwater application at Redstone Arsenal, Alabama. Following this demonstration, the project was modified to also demonstrate the WBA ion exchange process for removing perchlorate in a drinking water application. Ion exchange using perchlorate-selective WBA resin is effective for treating perchlorate contamination in surface, ground, or drinking water application. The primary advantages of ion exchange using WBA resin are the ease and simplicity of regeneration, the small volume of spent regenerating solution produced, the resulting lower operations and maintenance (O&M) cost of regeneration, and the lower cost and ease of disposal of the spent regenerating solution.

This ion exchange process developed takes advantage of the pH-dependent nature of WBA resins. At low pH, functional groups on these resins have a positive charge (i.e. $R-NH_3^+$), allowing for anion exchange. However, at high pH, the resin functional groups lose a proton and are uncharged (i.e. $R-NH_2$), allowing for regeneration (see Figure 1).

WBA resin in free-base form ($R-NH_2$) is ionized ($R-NH_3^+$) by protonating with acid (H^+):



Protonated resin removes anions (A^-) from aqueous streams:



Spent resin ($R-NH_3-A$) is regenerated by neutralizing with caustic (NaOH), which liberates anions and returns resin to the free-base form:



Figure 1. WBA Resin Chemistry.

2.2 PROCESS DESCRIPTION

The WBA ion exchange process was designed to use standard equipment for ion exchange vessels, pH control and carbon dioxide stripping, and data acquisition. The process was also designed for minimal pumping operations and for using level sensors, flow meters, and programmable logic control for operation. The installation and operation requirements depend on specific site characteristics. In most cases, the system would need to be installed inside a building to provide security and protection from the elements.

The ion exchange process using WBA resins consists of three unit operations: pre-treatment, ion exchange, and post treatment (Figure 2). The general function for these unit operations are to

reduce the pH of the groundwater (near pH 4), remove perchlorate using WBA resin, and restore pH and alkalinity of the groundwater to acceptable levels, respectively. These operations are described in detail in Section 2 of the Final Report dated March, 2008.

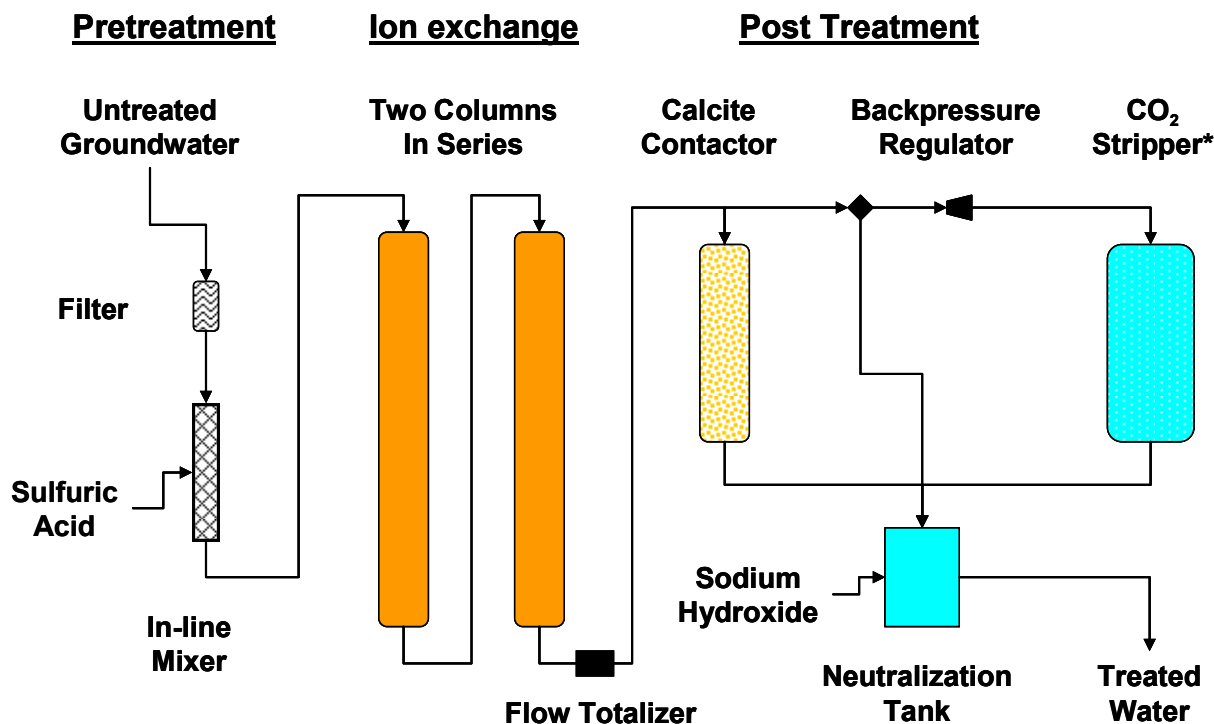

*CO₂ removal was demonstrated using either an air stripper or Liqui-Cel membranes.

Figure 2. Demonstration Process.

Regeneration is accomplished by increasing the pH of the spent resin to neutralize the functional groups. Once regeneration is complete, the resin is prepared for service by reducing the pH and protonating the functional groups. SBA resin Purolite A530E was used to scavenge perchlorate from the residual spent regenerant solution generated from regeneration. Detailed descriptions for regeneration, protonation, and treatment of spent regenerating solution are described in Section 2.1 of the Final Report.

2.3 PREVIOUS TESTING OF THE TECHNOLOGY

Remediation of groundwater containing perchlorate using the weak base anion technology was successfully demonstrated at Redstone Arsenal under ESTCP Project ER-0312. Detailed results of this demonstration are provided in the submitted Final Report (Groundwater Remediation – Pilot-Scale) and Cost and Performance Report (Groundwater Remediation – Pilot-Scale).

2.4 ADVANTAGES AND LIMITATIONS OF THE TECHNOLOGY

Three technologies are currently used commercially for remediating perchlorate-contaminated groundwater: 1) biodegradation, 2) ion exchange using regenerable resins, and 3) ion exchange

using non-regenerable or disposable resins. The WBA resin technology takes advantage of the performance, favorable public perception, and regulatory acceptance of ion exchange while minimizing the liabilities of current ion exchange systems. These liabilities include 1) high cost of perchlorate-selective resins currently in use, 2) large volume of residuals generated by regenerable systems, 3) difficulty and high cost of treating residuals, and 4) resin replacement and incineration costs for non-regenerable systems.

Weak base, perchlorate-selective resins do not have the treatment capacity of strong base, perchlorate-selective, single-use resins. Even so, overall cost savings may be substantial since the WBA resins can be economically regenerated. Pretreatment and post treatment steps required for the WBA resin process do add process complexity compared to single-use ion exchange systems. However, the complexity is not greater than other commercial, regenerable ion exchange technologies. Pre-treatment and post-treatment unit operations are very straightforward pH control processes.

Water quality parameters including alkalinity, hardness, perchlorate concentration, sulfate concentration, and treated water alkalinity affect cost and performance. The amount of acid required to achieve operating pH is directly proportional to feed water alkalinity and, therefore, pre-treatment cost. perchlorate concentration dictates the resin treatment capacity and regeneration frequency, which affects regeneration cost. In addition, perchlorate concentration and regeneration frequency impact the amount of spent regenerating solution and treatment cost. Hardness and desired alkalinity of treated water affect the caustic requirement for neutralization, which affects neutralization cost. Competing ions such as nitrate will also impact treatment performance by driving a need for more frequent regenerations. Competing ions is a limitation of all ion exchange technologies.

Sulfate concentration can also affect pre-treatment cost. The most economical pre-treatment approach is to use sulfuric acid (H_2SO_4). However, the use of H_2SO_4 will increase the residual sulfate concentration. If feed alkalinity and sulfate concentrations are high, residual sulfate concentration could exceed the National Secondary Water Treatment guideline of 250 ppm (the Secondary Water Treatment guideline for sulfate in California is 500 ppm). In cases where the concentration of sulfate would exceed secondary treatment guidelines, it may be necessary to replace some or all of the H_2SO_4 with the more expensive hydrochloric acid (HCl).

This page left blank intentionally.

3.0 DEMONSTRATION DESIGN

3.1 PERFORMANCE OBJECTIVES

The primary means of assessing performance of WBA ion exchange, regeneration, and residual treatment during this drinking water demonstration was to collect and analyze samples of treated water for perchlorate. Analytical results were used to determine the treatment capacity of the WBA resin at the conditions tested. Operational data collected were used to validate operating cost of this technology. Table 1 lists the performance objectives for this demonstration and whether they were met. Each performance objective listed is described in Section 3.1 of the Final Report (Drinking Water Treatment – Pilot-Scale).

Table 1. Performance Objectives.

Type of Performance Objective	Primary Performance Criteria	Expected Performance (Metric)	Actual Performance Objective Met?
Ion Exchange			
Qualitative	System operability	No process interruptions	Yes
Qualitative	System reliability	Reliably treats perchlorate, controls pH and alkalinity	Yes
Qualitative	System scalability	Ability to predict performance for larger scale systems	Yes
Quantitative	Meet perchlorate regulatory standards for drinking water	Treated water \leq MCL (6 ppb)	Yes
Quantitative	Demonstrate WBA resin capacity for drinking water application	$> 12,000$ bed volumes (BV)	No
Quantitative	Demonstrate post-treatment dial-in capability using stripping and neutralization	$1.0 > \text{LSI} > -1.0$ (i.e., noncorrosive and nonscaling)	Yes
Quantitative	Resin regeneration	No perchlorate bleed in subsequent test period \leq MCL (6 ppb)	Yes
Quantitative	Process waste	< 0.05 vol% residual	Yes
Quantitative	Low O&M treatment cost	$< \$100/\text{acre foot (AF)}$	Yes
Quantitative	Treatment of spent regenerating streams—scavenging of perchlorate	\leq maximum contaminant level (MCL)	Yes
Quantitative	Resin capacity following regenerations	Deviation of calculated perchlorate capacity does not exceed 10%	Unable to determine
Quantitative	Treatment flow rate	Operate at flow rate $\geq 3 \text{ gpm}/\text{ft}^3$	Yes

3.2 SELECTING TEST SITES

The main criteria for site selection included the following: 1) drinking water utility with 10-30 ppb perchlorate contamination in California, 2) site interest in hosting the demonstration and working with the California Department of Public Health Services (CDPH) to modify their existing permit to include this technology, and 3) existing wells and infrastructure providing access to the contaminated waters. Based on these criteria, the San Gabriel Valley Water District, Valley County Water District, East Valley Water District, the City of Colton, and the City of Rialto were considered. Representatives from each of these organizations were contacted to research available wells and infrastructure, water properties, and interest in hosting the demonstration. Representatives from Colton and Rialto indicated that they would be unable to support this demonstration due to other activities and ongoing demonstrations. Representatives from San Gabriel Valley Water District provided information for two potential sites, one in San Bernardino County and the other in Los Angeles County. Based upon their recommendation, well site F17, operated and managed by the Fontana Water Company and located in San Bernardino County, was selected for the demonstration.

3.3 TEST SITE/FACILITY HISTORY/CHARACTERISTICS

The Fontana Water Company is a retail investor-owned utility company that provides water to approximately 160,000 residents, mainly in the City of Fontana. The company also serves portions of the cities of Rancho Cucamonga and Rialto. Initially, wells F17B and F17C were to be used for this demonstration. However, well F17B was shut down and rescreened due to high nitrate concentrations. For this reason, only water from well F17C was used throughout the demonstration. Well F17C was drilled in 1994 and has a production rate of 3,000 gpm. Currently, water from this well is treated by an ion exchange process that uses non-regenerable, SBA resin.

3.4 PHYSICAL SETUP AND OPERATION

The ion exchange pilot treatment system used during the demonstration at Redstone Arsenal (ER-0312) was modified for use in this drinking water demonstration. Modifications included fabrication and installation of 1) column feed and effluent manifolds for flow flexibility, 2) a regeneration and protonation system for on-site regeneration, 3) a scavenger resin system to treat spent regenerating solution onsite, 4) a manifold and flow control system for the post-treatment process, 5) a CO₂ stripping column, and 6) a calcite contacting column. The entire system was housed in an 8-ft by 20-ft enclosed trailer that provided breakered power, climate control, and protection from the elements while in the field. Utility hookups, including power and communication, were coordinated with Fontana staff prior to field mobilization. The pilot system was transported to Fontana, California and set up at the site selected. Setup was accomplished in two days.

The Purolite Company provided ARA with 1.0 cu ft of commercial D-4170 resin from a single batch. ARA used only a fraction of this resin (4 liters [L]) for this demonstration. The resin used for this demonstration and the demonstration at Redstone Arsenal came from the same batch of Purolite D-4170 resin.

Ion exchange columns were prepared at the Panama City Research Facility prior to installation in the field. The standard resin-loading protocol used for this demonstration included the following steps: 1) load an accurately measured amount (2 L per column) of virgin WBA resin (Purolite D-4170) in the free-base form using neutral pH, distilled water slurry; 2) rinse the resin with neutral pH water; 3) protonate the resin using H₂SO₄; 4) regenerate the resin using sodium hydroxide (NaOH); and 5) re-protonate the resin using H₂SO₄. Before startup, the resin in each column was classified on site by circulating one gallon of distilled water with the pH adjusted to 4.0. The pilot system was manned full-time during the setup and start-up period (2 weeks). Two local technicians were trained during this period and were responsible for maintaining system operation, recording operational data, and collecting and shipping samples three times per week. The local technicians also responded to unforeseen operational or data acquisition anomalies with guidance from ARA. ARA personnel conducted on-site visits every 3 to 4 weeks to perform resin regeneration and scavenger treatment tests on the spent regenerant.

Disinfection of the pilot system was conducted prior to initiating the demonstration by flowing potable water at a pH of 12.5 or higher through all interconnecting piping. This solution was circulated through the piping for 4 hours. Following circulation, the high pH solution remained in the system for 12 hours. Under these conditions, bacterial cell walls lyse, effectively disinfecting the system. Prior to start-up, the high pH solution was rinsed from the piping using potable water at the operational pH of 4.0. Before operation, resin was always classified by up-flow fluidization as part of the protonation rinse process. Since the resin was regenerated every 3 to 4 weeks, intermediate backwashing was neither necessary nor desirable.

The demonstration trailer was shipped from Panama City, Florida on May 12, 2006, and delivered to Fontana, California on May 16, 2006. After 2 days of set-up and column preparation, the system was initiated for groundwater treatment on May 18, 2006. From this date, the demonstration system was operated for approximately 15 weeks until September 1, 2006.

Table 2. Duration of Each Test Period.

ID	TaskName	Duration	Start	Finish	May		June				July				August				September				October				November					
					16	23	30	7	14	21	28	4	11	18	25	2	9	16	23	30	6	13	20	27	3	10	17	24	1	8	15	22
1	Demonstration Schedule	109 days	Tue 5/16/06	Fri 9/1/06																												
2	Site Arrival	0 days	Tue 5/16/06	Tue 5/16/06																												
3	Mobilization	3 days	Tue 5/16/06	Thu 5/18/06																												
4	Initiate GW Treatment	0 days	Thu 5/18/06	Thu 5/18/06																												
5	Test Period 1	27 days	Thu 5/18/06	Tue 6/13/06																												
6	Test Period 2	30 days	Tue 6/13/06	Wed 7/12/06																												
7	Test Period 3	8 days	Wed 7/12/06	Wed 7/19/06																												
8	Test Period 4	7 days	Thu 7/20/06	Wed 7/26/06																												
9	Test Period 5	20 days	Thu 7/27/06	Tue 8/15/06																												
10	Test Period 6	18 days	Tue 8/15/06	Fri 9/1/06																												
11	Demonstration Complete	0 days	Fri 9/1/06	Fri 9/1/06																												

Note: GW = groundwater

3.5 SAMPLING/MONITORING PROCEDURES

As part of the demonstration plan for this effort, a Quality Assurance Project Plan (QAPP) was developed and utilized to ensure that samples were collected and analyzed properly. This plan was developed based on guidance provided by CDPH representatives and ARA’s experience in operating ex situ groundwater treatment systems. The plan is included as Appendix B in the Final Report (Drinking Water Treatment – Pilot-Scale).

Site visits were conducted at least 3 days per week to inspect the system, record data, sample, and prepare dilute acid and/or caustic solutions for the pre- and post-treatment units. Inspection and sampling typically required an hour per site visit. There were five sample locations identified for the field demonstration system. These sampling points consisted of ball-valves that were plumbed in appropriate locations for representative sampling. Each valve was clearly labeled to eliminate confusion or mislabeling of sample bottles. These locations are identified in Figure 3.

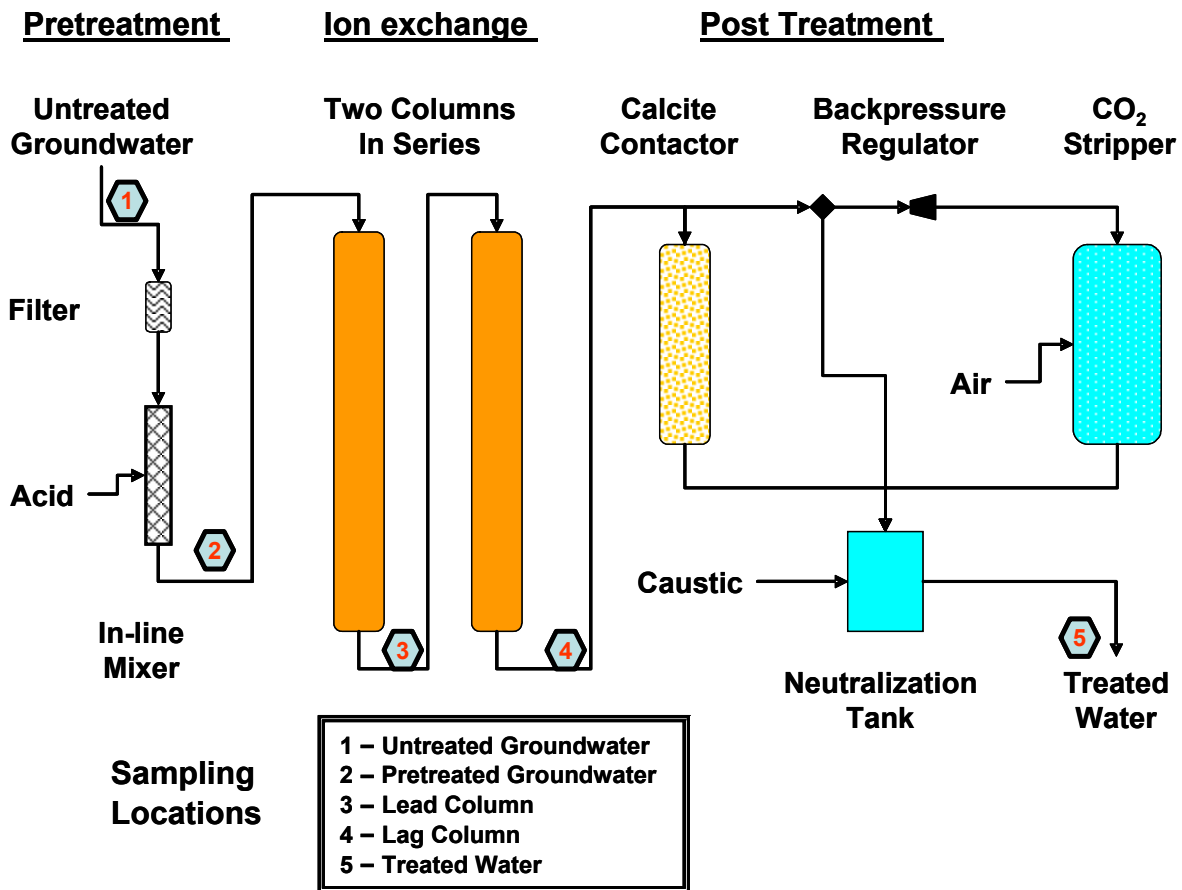

Figure 3. Sampling Locations.

Samples of the untreated water, pretreated water, lead and lag column effluents, and post-treated water were analyzed for perchlorate, other inorganic anions, and basic water quality parameters by ARA’s in-house laboratory and National Environmental Laboratory Accreditation Program

(NELAP) certified laboratories. The sampling frequencies for each parameter are listed in Table 3.

Table 3. Sampling Summary for ESTCP Pilot Demonstration.

Parameter	Sample Location	Sample Frequency	Method	#Samples Collected
Certified Laboratory				
Perchlorate	2 and 5	24 hr after start-up and final	EPA 314.0 or by IC-MS/MS*** or LC-MS/MS****	17
Anions (chloride, nitrate, and sulfate)	2 and 5	24 hr after start-up and final	EPA 300.1	17
General physical and mineral*	2 and 5	24 hr after start-up and final and at any post-treatment condition change	Various (see Table 3-5)	17
Nitrosamines**	1	At start-up	EPA 521 and/or 8270	1
Nitrosamines**	3 and 4	At start-up (<5 bed volumes [BVs]), at one week, and after regeneration	EPA 521 and/or 8270	17
Heterotrophic plate count	3 and 4	24 hr after start-up and final	9215	16
Total coliform	3 and 4	24 hr after start-up and final	9221	16
ARA				
Perchlorate	1, 2, 3, 4, 5	Start-up - 2, 20, and 100 BV; normal operation - 3X per week	EPA 314.0	305
Anions (chloride, nitrate, and sulfate)	1, 2, 3, 4, 5	Start-up - 2, 20, and 100 BV; normal operation - weekly	EPA 300.1	305

*General physical and mineral parameters include alkalinity, hardness, color, turbidity, conductance, pH, solids (total solids/total dissolved solids [TS/TDS]), and metals (Ca, Cu, Fe, Mg, Mn, K, Na, and Zn). Specific methods are listed in Table 5.

** N-nitrosodimethylamine (NDMA), N-nitrosodiethylamine (NDEA), N-nitrosodi-n-propylamine (NDPA), N-nitrosodi-n-butylamine (NDBA), N-nitrosomethylethylamine (NMEA), N-nitrosopiperidine (NPIP), N-nitrosopyrrolidine (NPYR), N-nitrosodiphenylamine (NDPhA), and N-nitrosomorpholine (NMOR)

*** IC-MS/MS = ion chromatography-tandem mass spectrometry

**** LC-MS/MS = liquid chromatography-quadruple spectrometry

Operational data including pH, flow, and pressure were collected and stored by a data acquisition system. These data along with acid and caustic tank levels were recorded in a log notebook by a technician on each sampling day. The technician would also call ARA personnel and provide the data while on site. This data was recorded in spreadsheets and reviewed to ensure that the system was operating as expected.

During regeneration tests, anion analyses (perchlorate, sulfate, nitrate, and chloride) were conducted on composite spent caustic regenerating solutions using EPA Methods 314.0 and 300.1. The anion results were used to determine regeneration effectiveness and anion composition of the regeneration solution before perchlorate destruction tests were initiated.

Spent regenerant solutions were treated using a by a “zero-discharge” approach by passing spent regenerant over a scavenger, SBA resin. During these zero-discharge tests, sampling was conducted on each BV passed through the scavenger resin. A sampling summary for regeneration and residual treatment tests is provided in Table 4.

Table 4. Sampling Summary for Regeneration and Residual Treatments.

Process	Parameter	Sample Frequency	Method	#Samples Collected
Regeneration	Perchlorate	Initial and final composite	EPA 314.0	5
	Anions	Initial and final composite	EPA 300.1	5
	pH	On-line	SM 4500	Continuous
Residual treatment	Perchlorate	Each BV and final composite	EPA 314.0	21
	Anions	Final composite	EPA 300.1	21
	pH	Final composite	SM 4500	8

3.6 ANALYTICAL PROCEDURES

Analyses were conducted by ARA’s laboratory in Panama City and by certified laboratories. A listing of analytical methods utilized by these laboratories is provided in Table 5, with detailed descriptions of the analytical methods used during this demonstration included with the QAPP, attached as Appendix B of the Final Report (Drinking Water Treatment – Pilot-Scale). The address of each laboratory is listed below:

In-House Analyses

Applied Research Associates, Inc.
 430 West 5th Street, Suite 700
 Panama City, Florida 32401
 Phone: 850-914-3188

External Analyses

Associated Laboratories
 806 North Batavia
 Orange, California 92868
 Phone: 714-771-6900
 NELAP #: 04232CA

Babcock Laboratory
 6100 Quail Valley Court
 Riverside, California 92507
 Phone: 951-653-3351
 NELAP #: 02101CA
 ELAP #: 1156

Table 5. Analytical Procedures Used During Demonstration.

Parameter	Matrix	Method	Volume	Container and Preservation	Hold Time
Perchlorate*	Aqueous	EPA 314.0	100 ml	HDPE***, Cool 4°C	28 days
Anions	Aqueous	EPA 300.1	100 ml	HDPE, Cool 4°C	28 days
Turbidity	Aqueous	SM 2130B	100 ml	HDPE, Cool 4°C	48 hr
Color	Aqueous	SM 2120B	50 ml	HDPE, Cool 4°C	48 hr
Hardness	Aqueous	SM 2340	100 ml	HDPE, Cool 4°C, ph<2, HNO ₃	6 mo
Alkalinity	Aqueous	SM 2320B	100 ml	HDPE, Cool 4°C	14 days
Conductance	Aqueous	SM 2520	100 ml	HDPE, Cool 4°C	28 days
pH	Aqueous	SM 4500	5 ml	N/A	Immediate
Solids (TS/TDS)	Aqueous	SM 2540	100 ml	HDPE, Cool 4°C	7 days
Metals (Ca, Cu, Fe, Mg, Mn, K, Na, Zn)	Aqueous	SM 3125	200 ml	HDPE, ph<2, HNO ₃	6 mo
Nitrosamines **	Aqueous	EPA 521	1000 ml	glass, Cool 4°C, 80-100 mg Na ₂ S ₂ O ₃	14 days
Heterotrophic plate count	Aqueous	SM 9215	100 ml	Presterilized container, Cool 4°C	16 hr
Total coliform	Aqueous	SM 9221	100 ml	Presterilized test tubes, Cool 4°C	16 hr

Notes: * Critical compound for performance validation is perchlorate. ** Nitrosamines include NDMA, NDEA, NDPA, NDBA, NMEA, NPIP, NPYR, NDPhA, NMOR. *** HDPE = high density polyethylene.



ARA Demonstration Trailer Beside Enclosure for Well F-17C in Fontana, California.



ARA Demonstration Trailer Containing Ion Exchange Equipment at Well-Site F-17 in Fontana, California.

4.0 PERFORMANCE ASSESSMENT

4.1 PERFORMANCE DATA

Data collected to evaluate the performance of this technology include anion concentrations, primarily for perchlorate; general mineral and physical data used for determining the scaling potential of treated water (LSI); and nitrosamine concentrations. These data are summarized in sections below. Operational data including pH and pressure were also recorded along with acid and caustic consumption of the pre-treatment and post treatment unit operations. Operational data as well as detailed results are provided in Appendix C of the Final Report (Drinking Water Treatment – Pilot-Scale).

4.1.1 Perchlorate

Samples were analyzed for perchlorate by ion chromatography (IC) using EPA Method 314.0 in ARA’s in-house laboratory and by a certified laboratory (Associated Laboratories). The detection limits for ARA and Associated Laboratories were 2.5 and 4.0 ppb, respectively. Another certified laboratory, Babcock Laboratories, was used to analyze perchlorate at lower detection limits using ion chromatography/mass spectrometry (IC/MS)/MS. The RL varied due to matrix effects but was never greater than 1 ppb. A summary of perchlorate data at key sampling times is provided in Table 6. Data collected throughout the demonstration by ARA and certified laboratories for perchlorate and other anions including nitrate, sulfate, and chloride are provided in Appendix C of the Final Report (Drinking Water Treatment – Pilot-Scale). These data demonstrate that the WBA ion exchange process met or exceeded key primary goals, including removing perchlorate to below the maximum contaminant limit (6 ppb), continued effective perchlorate removal after multiple regenerations, and no observed perchlorate leakage during or after resin regeneration. During the demonstration, the average perchlorate concentration in the influent was 8 ppb. No spiking was conducted to increase the concentration of perchlorate.

Table 6. Perchlorate Data Summary Analyzed by ARA and Certified Laboratories.

Test Period	Column ID (Lead/Lag)	Date	Water Treated at Sampling (BV)	Perchlorate (ppb) Lead Column			Perchlorate (ppb) Lag Column			Comment
				ARA	Assoc. Labs	Babcock Labs	ARA	Assoc. Labs	Babcock Labs	
1	C3/C4	5/19/06	700	<2.5	--	--	<2.5	<4	--	28 hr after start-up
		6/7/06	11,700	5.1	--	4.1	<2.5	--	<0.10	Lead breakthrough
		6/12/06	14,800	9.4	--	6.5	<2.5	--	0.19	Lead breakthrough
2	C4/C3	6/15/06	1,200	<2.5	--	<1.0	<2.5	--	<1.0	50 hr after start-up
		6/26/06	7,800	4.5	--	4.5	<2.5	--	<1.0	Lead breakthrough
3	C4	7/13/06	300	<2.5	--	0.46	<i>Lag (C3) column off-line</i>			3 gpm/ft ³ - 16 hr
		7/14/06	1,100	<2.5	--	0.33				4 gpm/ft ³ - 40 hr
		7/17/06	3,700	<2.5	<4	0.26				4 gpm/ft ³ - 5 day
		7/19/06	4,900	<2.5	--	0.11				3 gpm/ft ³ - post regen
4	C4/C3	7/26/06	4,100	<2.5	--	--	<2.5	--	--	3 gpm/ft ³ - 5 day
5	C3/C4	8/14/06	11,200	6.4	5.9	--	<2.5	--	--	Lead breakthrough
6	C/4C3	8/16/06	24	<2.5	--	0.49	<2.5	--	0.29	1 hr after start-up
		9/1/06	9,200	4	5.5	--	<2.5	--	0.53	Lead breakthrough

4.1.2 Langelier Saturation Index

The LSI was used as the indicator of water quality. This index predicts the calcium carbonate (CaCO₃) stability of water, that is, whether a water will precipitate, dissolve, or be in equilibrium with CaCO₃ (the LSI should be as close to zero as possible). The index determines the pH at which water is saturated in CaCO₃. The LSI is expressed as the difference between the actual system pH and the saturation pH.

Key general physical characteristics and the LSI of the untreated groundwater and treated water are provided in Table 7. By controlling the pH, the amount of dissolved carbon dioxide stripped from the treated water and the volume of water passed over a calcite contactor column, it was demonstrated that treated water quality could be controlled to achieve a neutral LSI (a value between -1 and 1) with alkalinity reduced to as low as 27 ppm as CaCO₃.

Table 7. General Physical Data and LSI Value.

Test Period	Date	Untreated Groundwater at 77°F					Treated Water at 77°F				
		Hardness	Alkalinity	pH	TDS	LSI	Hardness	Alkalinity	pH	TDS	LSI
1	5/19/06	--	--	--	--	--	160	9	7.02	320	-1.76
	6/12/06	146	153	7.89	240	0.31	--	--	--	--	--
2	6/15/06	--	--	--	--	--	193	54	7.92	380	-0.01
	7/10/06	166	146	7.69	270	0.13	183	33.2	7.91	370	-0.25
3	7/17/06	--	--	--	--	--	210	39	7.62	380	-0.41
4	7/24/06	--	--	--	--	--	215	27	8.16	440	-0.03
5	7/27/06	--	--	--	--	--	171	15	7.45	420	-1.09
	8/15/06	166	153	7.72	290	0.19	172	12	7.82	376	-0.81
6	9/1/06	160	151	7.71	250	0.17	179	12	7.67	285	-0.93

Notes: Values for hardness and alkalinity are reported as CaCO₃. TSD = total dissolved solids

4.1.3 Nitrosamines

In ion exchange treatment processes, nitrosamine compounds have become an issue of concern to California regulators. For this demonstration, CDPH representatives recommended analyzing for nitrosamines including NDEA, NDMA, NDBA, NDPA, NMEA, NMOR, NPIP, and NPYR. The primary sampling times recommended were immediately after initiating the demonstration with virgin resin (within treating five BV), at the conclusion of a test period, and after a regenerated column was placed on-line. NDMA and NMOR were the only nitrosamines detected above the RLs. A summary of nitrosamine results and the condition at sampling are provided in Table 8.

Table 8. Nitrosamine Data Summary.

Condition	NDMA (ppt)		NMOR (ppt)	
	Lead	Lag	Lead	Lag
Reporting Limit (RL)	2	2	4	4
Virgin resin, start-up @ 5BV	7	6.2	9	13.4
Test 1; 11,100 BV	< RL	< RL	< RL	< RL
Test 1; 15,000 BV	2.1	2.2	< RL	< RL
Test 2; after regen; 5BV	2.6	--	< RL	--
Test 5; 11,000 BV	< RL	< RL	< RL	< RL
Test 6; after regen; 24 BV	--	< RL	--	< RL

4.1.4 Scavenger Treatment of Spent Regenerant

Spent regenerant generated from regeneration of the ion exchange columns was treated using a zero-discharge, scavenge process. The process consisted of two columns packed with 40 cu cm of SBA resin (Purolite A530E) and arranged in series. Spent regenerant was passed over the columns at a flowrate of 15 BV/hr. After treatment, the lead column was removed and replaced with the lag column for the next regeneration. A fresh column was installed to replace the promoted lag column. perchlorate in the treated spent regenerant was removed to concentrations below the detection limit (<2.5 µg/L) after passing through the lead column. A summary of anion concentrations in the spent regenerant and treated spent regenerant is provided in Table 9.

Table 9. Anions in Spent Regenerant and the Scavenged Regenerant.

Test	Spent Regenerant				Scavenged Regenerant			
	ClO ₄ ⁻ (ppm)	NO ₃ ⁻ (ppm)	Cl ⁻ (ppm)	SO ₄ ²⁻ (ppm)	ClO ₄ ⁻ (ppb)	NO ₃ ⁻ (ppm)	Cl ⁻ (ppm)	SO ₄ ²⁻ (ppm)
1	14	2973	156	9286	< 2.5	2743	338	9219
2	16	3081	165	9839	< 2.5	3163	163	9985
3	11	3029	157	9882	< 2.5	2876	216	9693
4	17	3455	177	10543	< 2.5	3309	228	10337
5	39	3218	161	9333	< 2.5	3173	208	9390

4.2 PERFORMANCE CRITERIA

The effectiveness and success of this demonstration were measured against the primary and secondary performance objectives. Table 10 summarizes the expected performance, performance confirmation methods, and the actual confirmation methods for all primary and secondary objectives. Detailed descriptions can be found in section 3.1 of the Final Report (Drinking Water Treatment – Pilot-Scale). Assessment of criteria was based on comparing sampling results and operating data. Many of the primary performance criteria were based on comparing perchlorate concentrations of groundwater or pretreated groundwater to column effluents using EPA Method 314.0. For this reason, care was taken to ensure that sampling and analysis of these samples were compliant with the QAPP used during the demonstration, attached as Appendix B in the Final Report. Quality control results for perchlorate analyses are summarized in Appendix C of the Final Report. Every effort was made to comply with the criteria listed. If the criteria were not met, samples were re-analyzed on the next analysis day. It was especially challenging to meet the percent recovery goal for matrix spikes due to the very low perchlorate concentration in the groundwater, which was typically ≤ 8 ppb (matrix spike added was 10 ppb). For this reason, an alternate quality control plan was implemented using goals described by Standard Methods for the Examination of Water and Wastewater, 20th Edition, Section 1020 B – Quality Control. This reference recommends the use of accuracy (mean) control charts. These charts are constructed from the average and standard deviation of data gathered of the analyte of interest. The charts include lower and upper warning levels, which are set at ±2 and ±3 standard deviations, respectively. The quality control data for perchlorate analysis, including the accuracy, are provided in Appendix B of the Final Report (Drinking Water Treatment – Pilot-Scale).

Table 10. Expected Performance and Performance Confirmation Methods.

Performance Criteria	Expected Performance Metric (pre demo)	Performance Confirmation Methods	Actual (post demo)
PRIMARY CRITERIA (Performance Objectives)			
System operability	System operates as designed and configured without process interruptions due to process failures.	Record any process interruptions and determine cause	No process interruptions or upsets occurred due to process design or system failure.
System reliability	Very little perchlorate leakage	EPA method 314.0	The system reliably removed perchlorate with no leakage observed, even during regenerations.
Contaminant reduction	Remove perchlorate to \leq 6 ppb	EPA method 314.0	Perchlorate concentration in the treated water was below the criteria (6 ppb) in the lead columns until breakthrough. In the lag columns, perchlorate concentration was always below 0.5 ppb.
WBA resin capacity	Drinking water treatment capacity >12,000 BV	Treatment capacity/ breakthrough analysis	The average treatment capacity was approximately 9,700 BV.
Resin regeneration	Effective and efficient regeneration and rinse of WBA resin enabling reuse without substantial perchlorate bleed	EPA method 314.0	Perchlorate concentrations in treated water immediately after resin regeneration never exceeded 0.5 ppb.
Process waste	Volume of spent regeneration solution is < 0.05% of the water treated	Measure spent regenerant volume and volume of treated water using calibrated flow meters	The percentage of spent regenerant as a function of the estimated treatment capacity (19,400 L or 9,700 BV) was determined for test periods 1 through 5. All were below the expected metric of 0.05%.
Scavenging	Remove ClO_4^- from regenerant solution to less than MCL	EPA method 314.0	Perchlorate concentration in all treated spent regenerant samples was always below the detection limit (2.5 ppb).
Cost	Low O&M treatment cost	Determine O&M cost from performance data	O&M cost calculated to be less than \$100/AF
Perchlorate capacity following regeneration	Deviation of calculated perchlorate capacity does not exceed 10%	Calculate perchlorate sorbed to resin during treatment and recovered during regeneration for all test periods and compare.	Unable to evaluate this criterion due to very low and fluctuating perchlorate concentration in the groundwater

Table 10. Expected Performance and Performance Confirmation Methods (continued).

Performance Criteria	Expected Performance Metric (pre demo)	Performance Confirmation Methods	Actual (post demo)
SECONDARY CRITERIA (Performance Objectives)			
System reliability	pH Control	On-line pH monitor recorded with data acquisition system (DAS)	The DAS recorded a 9-hr period without pre-treatment pH control on July 31, 2006. The pH of the lag column effluent never exceeded 4.6 and perchlorate was not detected in samples collected from columns following loss of pH control.
	CO ₂ management	Influent/effluent alkalinity measurements	Alkalinity was managed by stripping dissolved CO ₂ and restoring alkalinity using a calcite contactor. An air stripping unit stripped CO ₂ during the first three test periods. A membrane stripping unit stripped CO ₂ for the remaining test periods.
Post-treatment capability	Able to “dial in” post-treatment stripping and neutralizing controls based on treated water requirements	pH and alkalinity of post-treated water compared to requirements; LSI analyses	Attained LSI near zero with alkalinity reduced to < 30 ppm as CaCO ₃ .
Scale-up constraints	Representative bed depths, flow rates, pre/post-treatment scale	System meets primary performance criteria	Resin bed depth for the pilot demonstration was equivalent to the resin bed depth in full-scale ion exchange vessels. Therefore, the ion exchange performance demonstrated was representative of full-scale system performance with no scale-up constraints.

4.3 DATA ASSESSMENT

An assessment of key items specific to this demonstration is summarized in Table 11. An assessment of performance data for ion exchange, regeneration, and perchlorate destruction in spent regenerant streams is provided in Section 4.1 of this report.

Table 11. Demonstration Assessment.

Item/Issue	Assessment
Performance	Data analyzed for meeting performance objectives met analytical criteria identified in the demonstration plan (i.e. quantity, precision and accuracy). Deviations from the QAPP for determining quality control of perchlorate concentration are summarized in Section 4.2. All sampling personnel were trained to properly collect and store samples according to Appendix B (QAPP) in the Final Report (Drinking Water Treatment – Pilot-Scale).
Regulatory	Perchlorate concentration in treated water was reduced to well below California’s maximum contaminant limit (6 ppb).
Training requirements	Two technicians (a primary and a backup) were trained over an 8-hr period to safely and properly inspect, sample, and monitor the system at least 3 days per week.
Health and safety requirements	Health and safety considerations are summarized in Appendix E (Health and Safety Plan [HASp]) of the Final Report (Drinking Water Treatment – Pilot-Scale). Specific requirements for this demonstration included proper training and equipment for handling acids and bases.

Table 11. Demonstration Assessment (continued).

Item/Issue	Assessment
Ease of operation	Ion exchange operation was a continuous flow process that required inspecting, monitoring, and replenishing of acid and base solutions used in pre-and post-treatment operations. More effort was required during regeneration including carefully following a regeneration protocol and checklist, adjusting valves appropriately, and collecting samples. Much of this would be automated for a large-scale treatment system.

4.4 TECHNOLOGY COMPARISON

This technology was compared to existing ion exchange technologies being used primarily to treat drinking water. These technologies include regenerable ion exchange processes that use salt as the regenerating agent such as the Calgon ISEP process and conventional lead-lag processes. The key performance benefits of the WBA process are associated with the volume, properties, and treatment options of spent effluent generated during regeneration. A general performance comparison of the WBA process and strong base anion (SBA) exchange processes is provided in Table 12.

Table 12. Performance Comparison WBA and SBA Systems.

Performance Characteristic	WBA System	Regenerable SBA System	Single-Use SBA System	WBA Benefit
Regeneration chemicals (TDS)	Acid and base (<3%)	Sodium chloride brine (~7-8%)	N/A	National Sanitation Foundation (NSF) certified chemicals; lower TDS is easier to treat and dispose
Regeneration frequency	14-21 days	18-24 hr	N/A	Contributes to lower volume compared to SBA regenerable process. Eliminates plugging, channeling, and potential biological contamination compared to single-use SBA process.
Waste volume	<0.05% of treated water	1% of treated water	N/A	At least 20X more efficient than SBA regenerable process
Waste	Perchlorate-free solution	Perchlorate in salt brine	Perchlorate contaminated spent resin	Perchlorate is easily removed from WBA waste by scavenging or biodegradation prior to discharge
Resin life (assuming 200 ppb perchlorate)	~7 yr	~5-7 yr	4-6 mo	Greater resin life than regenerable SBA process. Significant cost savings in resin purchase compared to single-use SBA process.
Treatment rate	3-4 gpm/ft ³	4 gpm/ft ³	4 gpm/ft ³	Equivalent treatment rate

Issues associated with the WBA process include: 1) added complexity required for pre-treatment and post-treatment operations; 2) additional labor required for operation and maintenance; 3) potential safety issues associated with handling and adding acid and base to product water; and 4) higher capital investment associated with additional unit operations and footprint. These issues are comparable to the ISEP regenerable system. When compared to a conventional,

single-use SBA treatment system, the primary benefit of the WBA process is cost savings when perchlorate concentration in the contaminated water is expected to be high (≥ 50 -100 ppb). A cost comparison is provided in Section 5.3 of this report.

This page left blank intentionally.

5.0 COST ASSESSMENT

5.1 COST REPORTING

Based on demonstration results, capital and O&M cost data were developed for a full-scale (1,000 gpm) groundwater treatment system using the WBA process. The cost data are representative for treating groundwater containing low concentrations of perchlorate typical for most drinking water applications. The following sections identify and describe assumptions and design bases used for cost development.

5.1.1 Capital Cost

5.1.1.1 Process Configuration

The process configuration in Figure 4 is the basis for capital and operating cost analysis. In this configuration, H_2SO_4 is added to the feed water under pressure to lower pH to approximately 4.3. After ion exchange in a two-stage, lead-lag vessel configuration, post-treatment is accomplished by a combination of membrane degassing, calcite treating, and pH adjustment. LiquiCel membranes will be used to degas approximately 90 to 95% of the treated water and the remaining 5 to 10% will be passed through a calcite contactor. Caustic will be added if necessary for final pH adjustment. For large applications (>1,000 to 3,000 gpm), degassing may be more economically accomplished using an air stripper. Pre-treatment and post-treatment processes will vary dependent on water composition, presence of co-contaminants, flow rate, and local requirements. Cost data developed for treating spent regenerant in this scenario are based on using the zero discharge scavenger method.

Resin regeneration will be accomplished in situ. While the lead vessel is off-line for regeneration, the lag vessel will remain in service. Figure 5 shows the four regeneration steps.

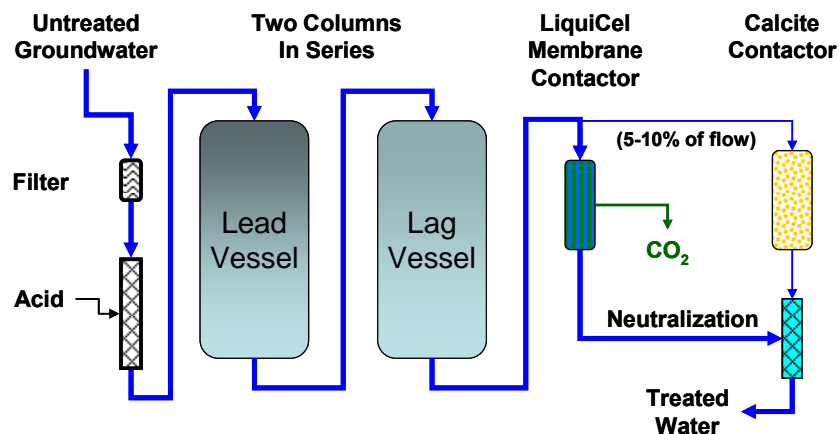

Figure 4. Process Configuration for Capital and O&M Cost Analyses.

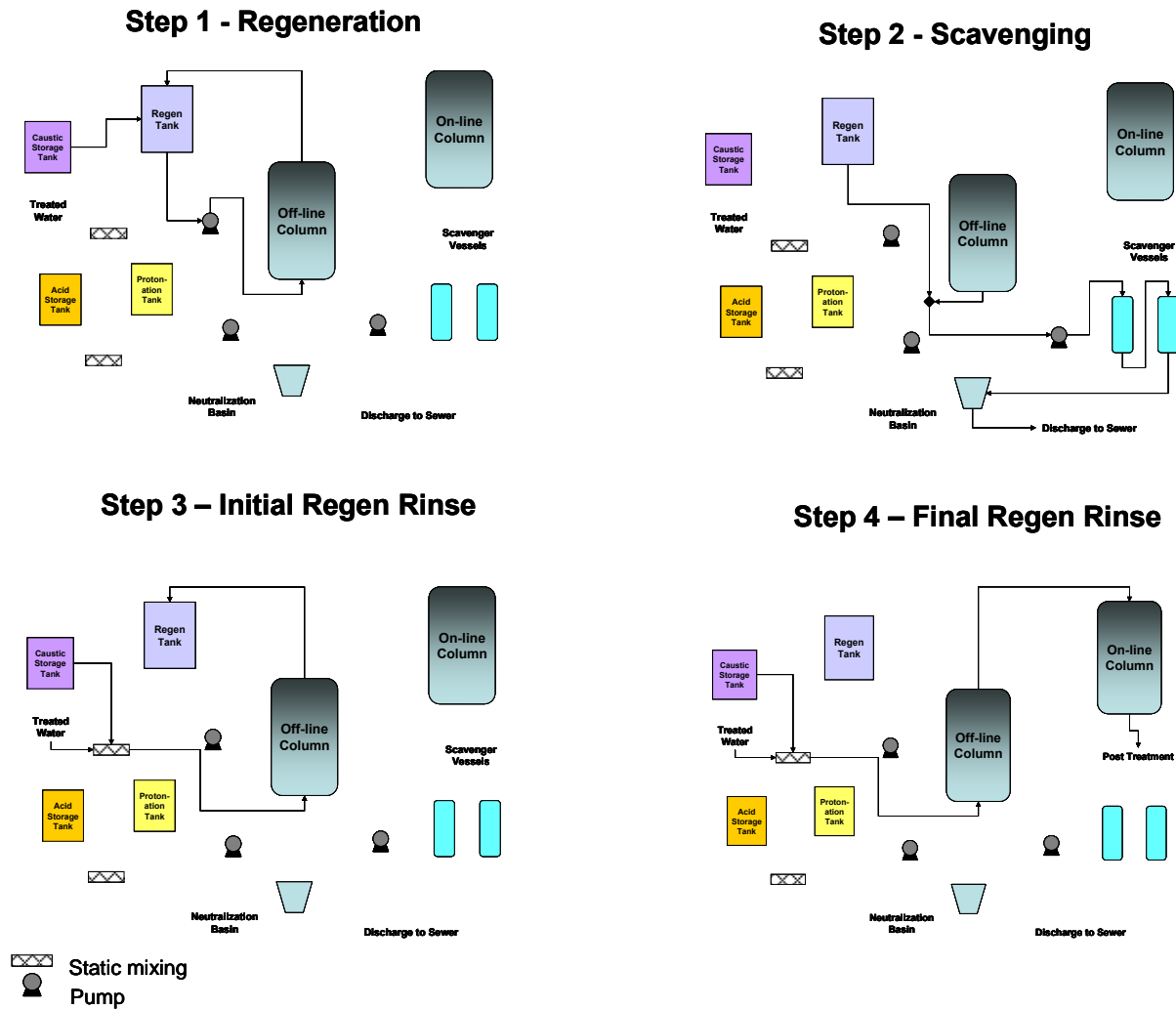

Figure 5. Regeneration Operations.

Regeneration (Step 1) is accomplished in a batch operation where the regeneration water volume is limited to approximately two BV. Regeneration is initiated countercurrent (up flow) immediately after the lead vessel is removed from service and without draining groundwater. Sufficient caustic (NaOH) is metered into the regeneration tank to neutralize all resin exchange sites and achieve a pH greater than 12.0 in the ion exchange vessel effluent.

Spent regenerating solution is drained from the ion exchange vessel and pumped from the regeneration tank into the scavenger ion exchange system (Step 2). The scavenger ion exchange system must be large enough to minimize the frequency of resin replacement and minimize the time to treat each batch of spent regenerating solution. Two 30 ft³ transportable ion exchange vessels operated in series (lead-lag) are sufficient for this task. SBA resin, Purolite A-530E, is used to scavenge perchlorate from the concentrated spent regenerating solution. The treated regenerating solution is neutralized and discharged to sewer.

A pH 9 rinse is necessary to remove residual perchlorate from the resin before protonation. The rinse water is prepared by on-line injection and mixing of caustic into a slipstream of treated

water. The total rinse of 24-36 BV is sufficient to control perchlorate bleed to less than 1 ppb. The first 2 BV of this rinse are pumped into the empty regeneration tank and retained for use in the subsequent regeneration (Step 3). The remainder of the rinse is pumped to the pre-treatment system for subsequent perchlorate treatment by the on-line column (Step 4). This approach eliminates discharge of rinse water.

The regeneration process is completed by ionizing or protonating the resin according to the two operational steps shown in Figure 6. After the pH 9 regeneration rinse is completed, protonation is accomplished by adding a metered amount of H₂SO₄ to a protonation tank and circulating the solution through the resin bed (Step 1). The pH of the solution returning from the resin should remain below ~4.3. A brief (6-8 BV) rinse at pH 4 is necessary to prevent a high sulfate excursion (>500 mg/L MCL) in the treated water (Step 2). The protonation rinse may be discharged after neutralization. After the rinse is complete, the vessel is returned to service in the lag position.

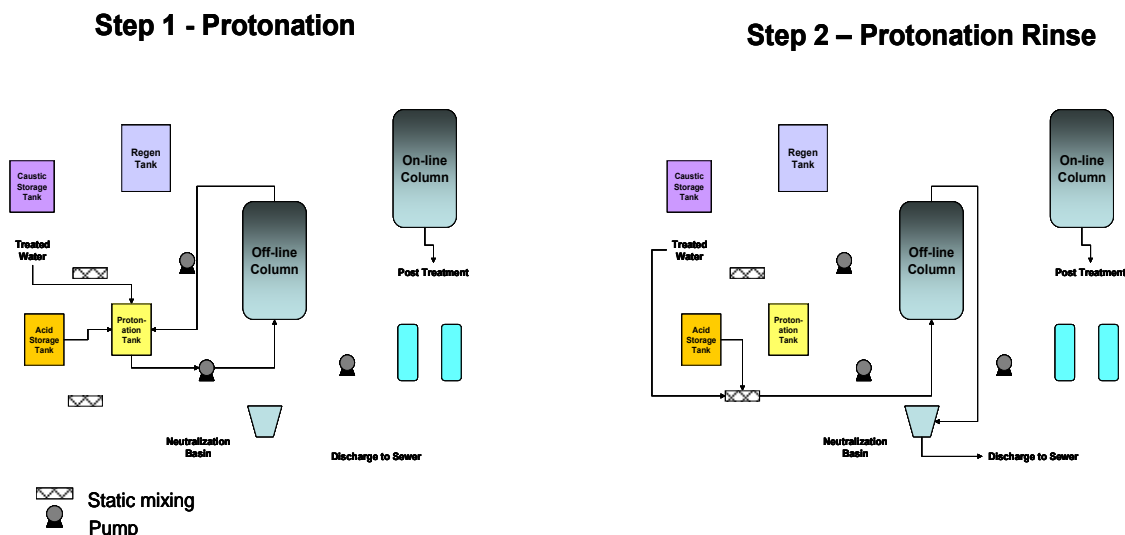

Figure 6. Protonation Operations.

5.1.1.2 Design and Operating Basis

The design and operating basis for developing cost data is summarized in Table 13. A treatment rate of 1,000 gpm was selected to permit direct comparison to ion exchange systems that typically treat 1,000 to 2,000 gpm per treatment train. A conservative treatment capacity of 9,700 BV was established based on pilot demonstration performance using Purolite D-4170 resin. Treatment capacities up to 50% higher can be obtained for water with lower nitrate concentrations based on the isotherm testing and data generated during the demonstration at Redstone Arsenal. The scavenger resin capacity is based on tests conducted that simulated 15 to 20 ppb perchlorate in the groundwater. Purolite A-530E resin was selected as the most economical scavenger resin from four candidates tested, including PWA2, A600 and A-520E. A summary of this cost analysis is provided in Appendix D of the Final Report (Drinking Water Treatment – Pilot-Scale). Higher perchlorate concentrations in the groundwater will result in higher loading capacities for the scavenger resins.

Table 13. Summary of Design and Operating Bases.

Parameter	Concentration
Treatment rate, gpm	1,000
BV/hr	24
Gpm/ft ³ of WBA resin	3
Groundwater composition	
Perchlorate, ppm	0.02
Nitrate, ppm	30
Sulfate, ppm	30
Alkalinity as calcium carbonate, ppm	150
Treated water composition	
Perchlorate, ppm	<0.001
Alkalinity as calcium carbonate, ppm	30
WBA resin treatment capacity, BV	9,700
Scavenger resin capacity, meq/L	250

5.1.1.3 Major Equipment

Table 14 provides a summary of major equipment requirements and cost. Capital costs were derived from budgetary cost estimates provided by architecture and engineering (A&E) firms and equipment vendors.

Table 14. Type and Quantity of WBA Equipment and 2007 Budgetary Cost Estimates.

Vessels	Quantity	Gallons	Total Cost
Acid storage tank w/containment	1	6,000	\$ 10,000
Caustic storage tank w/containment	1	3,000	\$ 7,000
Regeneration tank w/containment	1	6,000	\$ 10,000
Protonation tank w/containment	1	1,500	\$ 5,000
Dilute acid feed tank	1	300	\$ 1,500
Neutralization tank/basin	1	500-1,000	\$ 3,000
Pumps	Quantity	Head (ft)	Total Cost
Acid and caustic meter/transfer pumps	8	100	\$ 16,000
Regeneration pump	1	100	\$ 12,000
Protonation pump	1	100	\$ 12,000
Scavenger transfer/drain	1	60	\$ 10,000
Equipment	Quantity	Unit	Total Cost
Ion exchange vessels	2	10 ft dia.	\$ 200,000
Calcite contactor	1	100 gpm	\$ 30,000
LiquiCel Membranes	6	3 trains	\$ 60,000
Vacuum pump for membranes	1	30 SCFM	\$ 10,000
Bag filter (10 microns)	1	1,000 gpm	\$ 10,000
Static mixing elements – 1,000 gpm	2	pre & post	\$ 20,000
Static mixing elements – 100 gpm	2	regen	\$ 10,000
Transportable scavenger vessels	3	30 ft ³	\$ 10,500
PLC and I/O interface panels	1		\$ 60,000
Motor control panels	1		\$ 60,000
pH controllers	10		\$ 50,000
Control valves	2		\$ 80,000

Table 14. Type and Quantity of WBA Equipment and 2007 Budgetary Cost Estimate (continued).

Subtotal			\$	687,000
Equipment contingency (10%)			\$	68,700
Estimated Freight & Tax (15%)			\$	103,050
Equipment Capital Cost Estimate:			\$	858,750

5.1.2 Operating and Maintenance Cost

5.1.2.1 O&M Cost Components

The primary O&M cost components are acid and caustic consumed in pre-treatment, post-treatment, and regeneration operations. H₂SO₄ is the least expensive and safest strong acid to use for pre-treatment and for resin protonation after caustic regeneration. However, HCl may be used without major cost impact for treating low-alkalinity (<50 ppm) groundwater, or for scenarios that result in infrequent regeneration (>5,000 BV treatment capacity). NaOH is the least expensive and most efficient caustic to use for resin regeneration. In addition, high concentrations of sodium salts that result from the regeneration process will not cause precipitation or scaling problems, which could be the case if other caustic compounds were used for regeneration (i.e., potassium hydroxide).

Calcite and NaOH were used in the cost evaluation for post-treatment neutralization, which is required to restore pH and residual alkalinity for drinking water applications. Other caustic compounds, such as soda ash (Na₂CO₃) may be used for post treatment. Carbon dioxide stripping was accomplished using LiquiCel membranes. Electricity consumption and membrane replacement were considered in the cost analysis.

The WBA resin ion exchange treatment process is designed to eliminate the need for additional pumping operations. The cost for pumping water to the system is common to any pump-and-treat system and, therefore, was not included in this cost analysis. The power requirement for controls and for the small acid and caustic pumps used in this process will also be minimal. The power required for regeneration pumps will be significant; however, these pumps will operate intermittently with an anticipated duty cycle of less than 10-15%.

The cost of treating spent regenerating solution is included in the cost evaluation. For drinking water applications, this cost includes the cost for scavenger resin replacement and incineration. Scavenger resin vessels are small (30 ft³), transportable vessels that will be purchased as part of the system equipment but will be serviced by a third party. Spent regenerating solution from remediation of groundwater with high concentrations of perchlorate (>500 ppb), may be more economically treated using a continuously stirred tank reactor (CSTR) anoxic biodegradation process.

The full-scale ion exchange process will be fully automated—being controlled by a PLC—and require little labor. However, some labor will be required for maintenance; collecting samples; monitoring the receipt of acid, caustic, and scavenger resin; monitoring and evaluating system

performance; and monitoring resin regeneration (~once every 2 weeks). Average labor requirement is estimated to be 5 hours per week.

Macroporus styrene divinylbenzene WBA resin can maintain performance for over 5 years in industrial applications that require daily regenerations. Regeneration frequency for drinking water and remediation applications are predicted to be no more than 30 times per year based on pilot performance. Therefore, WBA resin life for groundwater treatment applications is predicted to be 7 years.

5.1.2.2 O&M Cost Basis

Table 15 provides a summary of the cost bases used for the major O&M costs. Chemical costs are based on quotes for bulk tank truck delivery to a southern California site (based on quotes from chemical companies, including Basic Chemical Solutions and Brenntag Pacific in 2007). Scavenger resin cost includes disposal and servicing costs for Purolite A-530E. WBA resin cost is the market price for commercially available Purolite D4170 resin as of early 2007.

Table 15. O&M Cost Basis.

Description	Cost
Sulfuric acid, 96-98%	\$0.05/lb
Sodium hydroxide, 50%	\$0.15/lb
Calcite	\$50/ton
Scavenger resin	\$180/ft ³
Weak base anion resin	\$500/ft ³
Resin handling and disposal	\$45/ft ³
Membrane replacement (every 3 years)	\$3,000 ea.
Electricity	\$0.10/Kw-hr
Operator labor	\$75/hr

Table 16 provides a summary of Capital and O&M cost for a 1,000 gpm drinking water treatment system. The normalized cost basis is dollars per AF of water treated. This is the most appropriate basis for comparing high flow rate remediation and drinking water treatment systems. One AF is equal to 325,851 gallons of water.

Purchased equipment cost in Table 16 was derived from the equipment unit and package costs and the quantities provided in Table 14. Capital costs were derived from budgetary cost estimates provided by A&E firms and equipment vendors in early 2007. A&E firms requested to provide cost estimates included Carollo Engineers, Case Engineering, Don Howard Engineering, and Anderson Water Systems. The other components of capital cost—site work and concrete, equipment installation and piping, electrical and instrumentation and controls installation, service facilities, engineering, construction expenses, and other indirect costs—are budgetary estimates provided by Carollo Engineers. These estimates are based on actual and factored estimates to complete actual construction of a similarly sized system to remove nitrate. These estimates took into account the unique complexities of unit operations required for the WBA system (i.e., pH monitoring and control systems).

Table 16. Cost Summary.

Cost Category	Cost Sub Category	Cost	
Capital Costs	Purchased equipment cost*	\$ 858,750	
	Site and concrete work	\$ 103,050	
	Equipment installation and piping	\$ 171,750	
	Electrical installation	\$ 128,813	
	Service facilities	\$ 85,875	
	Engineering	\$ 429,375	
	Construction expenses	\$ 171,750	
	Other indirect	\$ 85,875	
	SUBTOTAL:		\$ 2,035,238
	Start-up and testing expenses	\$ 75,000	
	Start-up resin and chemicals	\$ 370,000	
TOTAL CAPITAL COSTS:		\$ 2,480,238	
Annual Operating Costs	Labor	\$ 19,500	
	Consumables**		
	Sulfuric acid	\$ 30,500	
	Sodium hydroxide	\$ 14,700	
	Calcite	\$ 2,600	
	WBA resin replacement and disposal	\$ 51,900	
	Scavenger resin replacement and disposal	\$ 12,500	
	Membrane replacement	\$ 6,000	
	Electricity	\$ 9,700	
	TOTAL OPERATING COSTS:		\$ 147,400
	Quantity treated, AF	1,590	
Calculated unit O&M cost, \$/AF	\$ 92.69		

*Based on Table 14

** Based on Table 15

Start-up and testing costs are estimates that depend on specific site requirements and performance demonstrated for other similar applications. Start-up resin and chemical costs include the cost for the initial loading of weak base and scavenger resin, acid, caustic, and calcite. The estimated costs provided in Table 16 for start-up chemicals, annual consumables, and operation are based on the design and operating summary provided in Table 13 and the cost bases provided in Table 15. Labor costs were based on 5 hr/wk for drinking water applications.

5.1.3 Economy of Scale

There is significant economy of scale for multiple-train systems larger than 1,000 gpm. Regeneration and protonation tanks and pumps are underutilized in single-train, 1,000-gpm ion exchange treatment processes. Since regeneration and protonation can be accomplished in less than 2 days, the duty cycle for this equipment is less than 15%. Therefore, the regeneration equipment for a 1,000-gpm system could easily support the regeneration requirement for a five-train, 5,000-gpm treatment facility with little additional cost. A similar under-utilization situation exists with the scavenger-resin treatment equipment. The equipment used for the 1,000-gpm scenario would be adequate for a 5,000-gpm treatment system.

The pre-treatment and post-treatment operations would be performed in a common pre-treatment and post-treatment system regardless of the scale of the treatment operation. Pre- and post-treatment equipment costs would be scaled proportional to the treatment requirement, and the scaling exponent would be 0.5 or less. For large-scale applications (greater than 1,000 to 2,000 gpm), stripping towers will cost less to purchase and operate than membrane degassing equipment. The projected cost for a 4,000-gpm treatment system was developed and is provided in Table 17. Labor and electricity will be less per unit of water treated, which reduces the O&M cost for the 4,000 gpm treatment system by nearly 10%.

Table 17. Capital and Operating Costs for a 4,000 gpm Treatment System.

Category	Cost
Capital cost	\$6.1 M
Operating cost/AF	\$85

5.2 COST ANALYSIS

5.2.1 Major Cost Drivers

5.2.1.1 Groundwater Alkalinity

The amount of acid required for groundwater pre-treatment to attain the pH necessary for good performance is directly proportional to groundwater alkalinity. Acid cost is \$1.03/AF for every 10 ppm of bicarbonate alkalinity in the groundwater, based on H₂SO₄ at \$0.05/pound, delivered. In high pH water (>8), carbonate and hydroxide also contribute to the acid requirement. For the Fontana demonstration, the acid pre-treatment cost was \$18.50/AF of water treated.

5.2.1.2 Perchlorate Concentration

Higher perchlorate concentration in groundwater directly affects the amount of scavenger resin required for drinking water applications, which increases cost. Since perchlorate is very concentrated in spent regenerating solution, much more perchlorate can be exchanged onto a strong-base scavenger resin than is removed by the primary ion exchange resin (weak base or strong base, single-use resin) used to directly treat the groundwater. In scavenger tests conducted to simulate treating 20 ppb water, Purolite A-530E resin was the most economical resin based on treatment capacity (~240 to 250 meq/L), replacement cost (\$180/ft³), and disposal cost (\$45/ft³). Based on a loading of 250 ppm of perchlorate anion, the scavenger resin cost equates to about \$8/AF for a WBA process that removes 20 ppb of perchlorate from the groundwater.

5.2.1.3 Treated Water Alkalinity

Post-treatment cost is directly proportional to the alkalinity required in the treated water. This demonstration showed that treated water with an alkalinity as low as 30 ppm (as CaCO₃) possessed acceptable properties, i.e., would not contribute to either scaling or corrosion in water distributions systems. However, scaling indices, such as the LSI are a function of pH, temperature, calcium hardness, TDS, and alkalinity. Therefore, the post-treatment approach is

highly dependent on the water quality at each specific site. The approach taken for this cost analysis is to remove excess dissolved CO₂ by LiquiCel membranes and use calcite and caustic soda to achieve desirable treated water properties. Post-treatment cost (caustic, calcite, electricity, membrane replacement) for this scenario equates to \$17/AF based on 30 ppm of residual alkalinity (as CaCO₃). Alternative treatment approaches must be considered on a case-by-case basis and have the potential to reduce treatment cost.

5.2.1.4 Resin Regeneration Cost

Regeneration cost is dependent on resin treatment capacity, which is affected by other anions present in a specific groundwater. For a given water composition, treatment capacity is relatively independent of perchlorate concentration below 100 ppb because the perchlorate isotherms are linear between 1 and 100 ppb. In other words, the quantity of perchlorate anion exchanged is directly proportional to the concentration of perchlorate anion in untreated water. The regeneration costs for the Fontana demonstration was less than \$5/AF of groundwater treated based on a treatment capacity of 9,700 BV. Isotherm tests have shown that regeneration costs could be up to 50% less for low-TDS groundwater with lower levels of nitrate, sulfate, and chloride.

5.2.1.5 WBA Resin Cost

Resin replacement cost is a major component of operating cost for several reasons. The best performing commercial resin produced by Purolite costs \$500/cu ft. While this resin is commercially produced, production rates are relatively low at this time. Higher production rates may lead to reduced cost. perchlorate treatment systems for drinking water require a “multi-barrier” or two-stage, lead-lag treatment configuration. This configuration, in effect, doubles the amount of resin necessary for a treatment process. The annualized cost of resin replacement is about \$33/AF based on a 7-year service life. Resin replacement cost equates to about one-third of the total O&M treatment cost.

5.3 COST COMPARISON

Treatment costs in dollars per acre-foot (\$/AF) were evaluated for five different scenarios: 1) a WBA resin process for a 1,000-gpm drinking water application that uses a scavenger resin to treat spent regenerating solution; 2) a WBA resin process for a 4,000-gpm drinking water treatment system; 3) the SBA regenerable resin process (ISEP) using CalRes 2000 that is in operation at La Puente, California; 4) the single-use, SBA resin process using PWA2 resin that is in operation at the Lincoln Avenue Water Company site in Altadena, California; and 5) a proposed single-use, SBA resin process using CalRes 2100 or USF 9710 planned for Castaic Lake Water Agency, California. The cost analysis is summarized in Table 18.

Table 18. Present Worth Cost Comparison for Perchlorate Removal by Various Ion Exchange Technologies.

System:	WBA Regenerable	WBA Regenerable	SBA-ISEP Regenerable La Puente	SBA Single-Use Lincoln Ave.	SBA Single-Use Castaic Lake
Capacity, gpm	1,000	4,000	2,500	2,000	2,400
Treatment vol, AF/yr	1,591	6,364	3,978	3,182	3,818
Annual O&M Cost	\$ 147,400	\$ 532,000	\$ 1,950,000	\$ 1,084,124	\$ 940,000
Capital Cost	\$ 2,491,000	\$ 6,115,000	\$ 4,800,000	\$ 2,480,000	\$ 3,700,000
Interest Rate	6%	6%	6%	6%	6%
Plant Life	20	20	20	20	20
O&M Present Worth	\$ 1,690,666	\$ 6,101,998	\$ 22,366,346	\$ 12,434,817	\$ 10,781,726
Total Present Worth	\$ 4,181,666	\$ 12,216,998	\$ 27,166,346	\$ 14,914,817	\$ 14,481,726
Treatment Cost, \$/AF	\$ 131	\$ 96	\$ 341	\$ 234	\$ 190

Costs for the WBA scenarios are based on the data provided in Tables 16 and 17. Costs for the other scenarios were provided in a table published by CDPH dated October 14, 2004, and based on National Aeronautics and Space Administration (NASA) Action Memorandums dated August 24, 2004, and April 19, 2006. The actual costs provided for the ISEP process were \$2.8M for capital and \$1.6M for O&M. However, these costs did not include treatment or disposal of the perchlorate-contaminated, spent brine solution. ARA recently did an analysis under contract to the Baldwin Park Operable Unit (BPOU) – (controlling authority for La Puente) for brine treatment. The least expensive approach, biodegradation, would add \$2M in capital cost and \$350K in O&M cost. These costs were added to the values provided by CDPH and the sum used in Table 18. The Lincoln Avenue system is leased. An approximate estimate of capital cost was derived by multiplying the lease cost (\$9,500/mo) by the term (20 years) and adding known site improvement costs (\$200K). This lease cost was determined from published data and is the actual cost paid to the equipment vendor. The Castaic Lake system is proposed.

A 20-year plant life and 6% interest rate were used to determine the net present value of the operating costs. The results of this analysis clearly show that water treatment cost for the WBA technology are less than 25% of current regenerable resin systems (ISEP), and approximately 50% of the least expensive single-use resin systems. It is important to note that the treatment cost for the WBA technology is only slightly dependent on capital cost. This is due to the large difference in operating cost of the WBA technology compared to current technologies.

6.0 IMPLEMENTATION ISSUES

6.1 COST OBSERVATIONS

Key factors affecting cost were acid and caustic consumed in pre-treatment, post treatment, and regeneration operations. For pre-treatment, alkalinity of the contaminated water directly impacts the volume of acid required. H_2SO_4 is the least expensive strong acid to use for pre-treatment and for resin protonation after caustic regeneration. However, HCl may be used without major cost impact for treating low-alkalinity (<50 ppm as $CaCO_3$) groundwater, or for scenarios that result in infrequent regeneration (>5,000 BV treatment capacity).

The amount of alkalinity required in the post-treated water (water for discharge) directly impacts the cost of post-treatment. Calcite and NaOH were used in the cost evaluation for post treatment neutralization, which is required to restore pH and residual alkalinity for drinking water applications. Other caustic compounds, such as soda ash (Na_2CO_3) may be used for post-treatment. Use of soda ash and calcite for post treatment depends on treated water hardness and alkalinity requirements. Carbon dioxide stripping may not be required for low-alkalinity groundwater, or non-drinking water applications.

The concentration of perchlorate in the contaminated water will also impact the cost of this process. Higher concentrations will require more frequent regenerations. NaOH is the least expensive and most efficient caustic to use for resin regeneration. In addition, high concentrations of sodium salts that result from the regeneration process will not cause precipitation or scaling problems, which could be the case if other caustic compounds were used for regeneration.

6.2 PERFORMANCE OBSERVATIONS

Demonstration performance with respect to acceptance criteria for the performance objectives and the secondary performance criteria identified in the demonstration plan are discussed in Sections 3.1, 4.1, and 4.2 of this report. The performance criteria identified for the ion exchange process objectives were met. However, to mitigate failure or contaminant breakthrough using this technology, two redundancy measures were identified: 1) redundancy of pH monitoring and control for the pre-treatment operation will prevent neutralization and loss of capacity of the WBA resin if pH control was lost, and 2) configuring columns as lead and lag acts as a safety measure to prevent perchlorate leakage or breakthrough.

6.3 SCALE-UP

Ion exchange equipment availability can limit the treatment rate to 1,000 to 2,000 gpm; however, these systems can consist of multiple trains to overcome this limitation. There is significant economy of scale for multiple-train systems larger than 2,000 gpm. Regeneration equipment for a 2,000-gpm system could support the regeneration requirement for a 10,000-gpm treatment facility with little additional cost (see Section 5.1.3). A similar underutilization situation exists with the scavenger-resin treatment equipment. The equipment used for the 2,000 gpm scenario would be adequate for a 10,000-gpm treatment system.

The pre-treatment and post-treatment operations would be performed in single pre-treatment and post-treatment systems regardless of the scale of the treatment operation. Pre- and post-treatment equipment costs would be scaled proportional to the treatment requirement and the scaling exponent would be 0.5 or less. For large-scale applications (greater than 1,000 to 2,000 gpm), stripping towers will cost less to purchase and operate than membrane degassing equipment. The projected cost for a 4,000-gpm treatment system was developed and provided in section 5.1.3. Labor and electricity will be less per unit of water treated, which reduces the O&M cost for the 4,000 gpm treatment system by nearly 10%.

6.4 OTHER SIGNIFICANT OBSERVATIONS

Water quality parameters including alkalinity, hardness, perchlorate concentration, sulfate concentration, and treated water alkalinity affect cost and performance. The amount of acid required to achieve operating pH is directly proportional to feed water alkalinity and, therefore, pre-treatment cost. perchlorate concentration dictates the resin treatment capacity and regeneration frequency which affects regeneration cost. In addition, perchlorate concentration and regeneration frequency impact the amount of spent regenerating solution and treatment cost. Hardness and desired alkalinity of treated water affect the caustic requirement for neutralization, which affects neutralization cost.

The most economical pre-treatment approach is to use H₂SO₄. However, the use of H₂SO₄ will increase the residual sulfate concentration. If feed alkalinity and sulfate concentrations are high, residual sulfate concentration could exceed the National Secondary Water Treatment guideline of 250 ppm (the Secondary Water Treatment guideline for sulfate in California is 500 ppm). In cases where the concentration of sulfate would exceed secondary treatment guidelines, it may be necessary to replace some or all of the H₂SO₄ with the more expensive HCl.

6.5 LESSONS LEARNED

During this drinking water treatment demonstration, there were several lessons learned regarding process operations as well as analyses needed to provide data for regulatory acceptance. The following list summarizes these lessons.

6.5.1 Process Operations

- **Recycling of the regeneration rinse:** It was demonstrated that rinse water generated during the regeneration process could be recycled to the front of the system for treatment. Recycling and treatment of the rinse water was done successfully and without negative impact to the on-line treatment process (i.e., no perchlorate leakage). The benefits of rinse water recycling were: 1) the ability to conduct a thorough rinse, which eliminated perchlorate bleed after regeneration, and 2) no generation of perchlorate contaminated rinse water.
- **Effectiveness of membrane degassing, air stripping, and calcite treating for post-treatment:** It was demonstrated that a combination of air stripping, calcite treatment, and neutralization, or membrane degassing, calcite treatment, and neutralization are very effective post-treatment operations that reduce treatment

costs while restoring pH and alkalinity of treated water to acceptable levels. Treated water quality could be controlled to achieve a neutral LSI with alkalinity reduced to as low as 30 ppm as CaCO₃.

6.5.2 Regulatory Lessons

- **Low-level perchlorate analyses:** For regulatory acceptance by CDPH, in addition to EPA Method 314.0, it was recommended to analyze for perchlorate using “low-level” detection methods such as IC-MS/MS or LC-MS/MS. These methods can detect perchlorate to ppt levels in drinking water. Low-level detection methods were conducted by a certified laboratory during each test period to verify perchlorate removal and to demonstrate that perchlorate was not leaking during treatment of recycled rinse water. It is important to budget accordingly to include these analyses, because they can be up to 3.5 times more expensive than the typical IC method using EPA 314.0.
- **Nitrosamine analyses:** In ion exchange treatment processes, nitrosamine compounds have become an issue of concern to California regulators. For this demonstration, CDPH representatives recommended analyzing for nitrosamines including NDEA, NDMA, NDBA, NDPA, NMEA, NMOR, NPIP, and NPYR. The primary sampling times recommended were immediately after initiating the demonstration with virgin resin (within treating 5 BV), at the conclusion of a test period, and after a regenerated column was placed on-line. It is important to budget for these analyses and to verify that the certified laboratory selected has the capability to meet the detection limits desired by CDPH (down to 2 ppt for some analytes).
- **Drinking Water Supply Permit (DWSP) approval process:** To obtain permit approval for a new technology for drinking water requires completion of system design, engineering, and construction; preparation of engineering packages that include pilot test data; and testing and reporting of the full-scale system performance. This requires very close coordination with CDPH and local drinking water purveyors. Air and water discharge permits may also be necessary to obtain the DWSP. Water cannot be produced for consumption until after the DWSP is issued.

6.6 END-USER ISSUES

End-users for this technology include DoD facilities, formerly used defense sites, and municipal drinking water systems that have been contaminated with per perchloratechlorate by past DoD operations. In addition to drinking water applications, the technology can be used by the DoD for pump-and-treat perchlorate remediation and to facilitate remediation of co-contaminants, such as VOC by enabling the removal of perchlorate before discharge or re-injection. The technology can also be applied to the treatment of wastewater generated by munitions manufacturing or demilitarization operations.

Implementation of this technology is straightforward. Commercial, large-scale, ion exchange equipment for WBA resin technology exists. Pretreatment and post-treatment are simply pH control unit operations that are straightforward to design and engineer. Stripping tower design and engineering for CO₂ stripping are straightforward. Treatment of residuals by a scavenger ion exchange process is a proven technology. All processes operate at ambient temperature and low pressure (<~30 psig) and, therefore, present no unique engineering challenges or hazards.

The issues of primary concern for user acceptance are 1) the perception of operational complexity, 2) the need for acid and caustic on site, and 3) the need for a part-time operator. The regenerable nature of this ion exchange technology is by definition more complex than single-use resin technology, will require use of regeneration chemicals on site, and will require an operator. However, treatment systems can be designed to operate with little operator oversight. For instance, regeneration cycles can be initiated and executed automatically. End-user concerns may be offset for applications where water is highly contaminated; where regenerable ion exchange technologies are already in use; or where co-contaminants, such as nitrate, arsenic, or chromium, create the need for a regenerable ion exchange process.

6.7 APPROACH TO REGULATORY COMPLIANCE AND ACCEPTANCE

On January 26, 2006, the EPA adopted a RfD for perchlorate of 0.0007 mg/kg-day. This RfD equates to a DWEL of 24.5 micrograms per liter (or 24.5 ppb). As a result of EPA establishing an RfD for perchlorate, the DoD issued a policy letter that established 24 ppb as the “level of concern for managing perchlorate.” The letter further states that, “Once established, DoD will comply with applicable state or federal promulgated standards whichever is more stringent.” The letter also provides guidance for perchlorate with respect to sampling and analysis, record keeping, environmental restoration, operational ranges, drinking water systems, and wastewater discharges.

One of the objectives of this demonstration was to coordinate with CDPH to acquire a letter of conditional acceptance and acquire CDPH approval for this WBA resin ion exchange treatment process in drinking water applications. To accomplish this, we worked with CDPH to develop the sampling protocol in the QAPP used for this demonstration. A letter of conditional acceptance is contingent on the submission of the approved final report and any other supporting data requested by CDPH. Actual “approval” of the technology can only be obtained based on the design, engineering, and construction; preparation of engineering packages that include pilot test data; and testing and reporting of the full-scale system performance. This was beyond the scope of this effort.

A patent application was filed to protect this technology, which is jointly owned by ARA and Purolite. ARA and Purolite will market this technology to a wide range of clients. ARA has many contacts with DoD agencies addressing perchlorate concerns and DoD contractors. Purolite markets their products worldwide. Purolite provides over 50% of the resin currently being used to remove perchlorate from drinking water at approximately 20 different sites in the United States. It is in the best interest of Purolite and ARA to commercialize and transfer this technology to the DoD and the private sector.

7.0 REFERENCES

- Boodoo, Francis. The Purolite Company. (610) 668-9090. fboodoo@puroliteusa.com.
- Clesceri, Lenore, S., Andrew D. Eaton, and Arnold E. Greenberg. 1997. Standard Methods for the Examination of Water and Waste Water, 20th Edition.
- Collins, Heather. California CDPH Region V Regional Manager. (909) 383-4328. HCollin2@dhs.ca.gov.
- Davis, Andrea M. and Edward N. Coppola. 2006. Perchlorate Removal, Destruction, and Field Monitoring Demonstration Final Report (Groundwater Remediation – Pilot-Scale). ESTCP Project No. ER-0312.
- Davis, Andrea M. and Edward N. Coppola. 2006. Perchlorate Removal, Destruction, and Field Monitoring Demonstration Cost and Performance Report (Groundwater Remediation– Pilot-Scale). ESTCP Project No. ER-0312.
- Davis, Andrea M. and Edward N. Coppola. 2008. Perchlorate Removal, Destruction, and Field Monitoring Demonstration Final Report (Drinking Water Treatment – Pilot-Scale). ESTCP Project No. ER-0312.
- McCarthy, Sean. California CDPH San Bernardino District Engineer. (909) 383-4328. smccarth@dhs.ca.gov.
- Keith, Lawrence H. 1992. EPA's Sampling and Analysis Methods.
- Peters, Max S., Klaus D. Timmerhaus, and Ronald E. West. 2003. Plant Design and Economics for Chemical Engineers, Fifth Edition.
- Schweitzer, Philip A. 1979. Handbook of Separation Techniques for Chemical Engineers.

APPENDIX A

POINTS OF CONTACT

Point of Contact	Organization	Phone/Fax/E-mail	Role
Mr. Edward Coppola	ARA 430 W. 5th Street Suite 700 Panama City, FL 32401	850-914-3188 (phone) 850-914-3189 (fax) ecoppola@ara.com	Technical Manager
Ms. Andrea Davis	ARA 430 W. 5th Street Suite 700 Panama City, FL 32401	850-914-3188 (phone) 850-914-3189 (fax) adavis@ara.com	Project Manager
Mr. Steve Baxley	ARA 430 W. 5th Street Suite 700 Panama City, FL 32401	850-914-3188 (phone) 850-914-3189 (fax) sbaxley@ara.com	Quality Assurance (QA) Manager
Mr. Robert Girvin	ARA 430 W. 5th Street Suite 700 Panama City, FL 32401	850-914-3188 (phone) 850-914-3189 (fax) rgirvin@ara.com	Quality Assurance/Quality Control (QA/QC) Coordinator
Mr. Chris Diggs	Fontana Water Company 16803 Spring Street Fontana, CA 92335	909-822-2201 (phone) cdiggs@fontanawater.com	Fontana Water Site- Coordinator
Ms. Heather Collins	CDPH Drinking Water Field Operations Branch 464 W. 4 th Street Suite 437 San Bernardino, CA 92401	909-383-4328 (phone) 909-383-4745 (fax) hcollin2@dhs.ca.gov	CDPH Representative
Mr. Sean McCarthy	CDPH Drinking Water Field Engineer 464 W. 4 th Street Suite 437 San Bernardino, CA 92401	(909) 388-2602 (phone) 909-383-4745 (fax) smccarth@dhs.ca.gov	CDPH Representative
Mr. Bryan Harre	NAVFAC ESC 1100 23rd Avenue Port Hueneme, CA 93043	805-982-1795 (phone) 805-982-4304 (fax) bryan.harre@navy.mil	DoD Representative
Dr. Andrea Leeson	ESTCP 901 N. Stuart Street Suite 303 Arlington, VA 22203	703-696-2118 (phone) 703-696-2114 (fax) andrea.leeson@osd.mil	Technical Project Manager



ESTCP Program Office

901 North Stuart Street
Suite 303
Arlington, Virginia 22203
(703) 696-2117 (Phone)
(703) 696-2114 (Fax)
e-mail: estcp@estcp.org
www.estcp.org



ESTCP Program Office

901 North Stuart Street
Suite 303
Arlington, Virginia 22203
(703) 696-2117 (Phone)
(703) 696-2114 (Fax)
e-mail: estcp@estcp.org
www.estcp.org