



**NAVAL
POSTGRADUATE
SCHOOL**

MONTEREY, CALIFORNIA

THESIS

**CYBER SECURITY VULNERABILITIES DURING LONG
TERM EVOLUTION POWER-SAVING DISCONTINUOUS
RECEPTION PROTOCOL**

by

Navin Jaffer

June 2014

Thesis Co-Advisors:

John C. McEachen
David A. Garren

Approved for public release; distribution is unlimited

THIS PAGE INTENTIONALLY LEFT BLANK

REPORT DOCUMENTATION PAGE			<i>Form Approved OMB No. 0704-0188</i>
Public reporting burden for this collection of information is estimated to average 1 hour per response, including the time for reviewing instruction, searching existing data sources, gathering and maintaining the data needed, and completing and reviewing the collection of information. Send comments regarding this burden estimate or any other aspect of this collection of information, including suggestions for reducing this burden, to Washington headquarters Services, Directorate for Information Operations and Reports, 1215 Jefferson Davis Highway, Suite 1204, Arlington, VA 22202-4302, and to the Office of Management and Budget, Paperwork Reduction Project (0704-0188) Washington DC 20503.			
1. AGENCY USE ONLY (Leave blank)	2. REPORT DATE June 2014	3. REPORT TYPE AND DATES COVERED Master's Thesis	
4. TITLE AND SUBTITLE CYBER SECURITY VULNERABILITIES DURING LONG TERM EVOLUTION POWER-SAVING DISCONTINUOUS RECEPTION PROTOCOL		5. FUNDING NUMBERS	
6. AUTHOR(S) Navin Jaffer		8. PERFORMING ORGANIZATION REPORT NUMBER	
7. PERFORMING ORGANIZATION NAME(S) AND ADDRESS(ES) Naval Postgraduate School Monterey, CA 93943-5000		10. SPONSORING/MONITORING AGENCY REPORT NUMBER	
9. SPONSORING /MONITORING AGENCY NAME(S) AND ADDRESS(ES) N/A		11. SUPPLEMENTARY NOTES The views expressed in this thesis are those of the author and do not reflect the official policy or position of the Department of Defense or the U.S. Government. IRB protocol number ___N/A___.	
12a. DISTRIBUTION / AVAILABILITY STATEMENT Approved for public release; distribution is unlimited		12b. DISTRIBUTION CODE A	
13. ABSTRACT (maximum 200 words) Long Term Evolution (LTE) is a wireless access communications network that consists of base stations called eNodeBs (eNBs), which allow connectivity between the mobile device or user equipment (UE) and the core network. To save battery power, the UE can turn off its radio transceiver circuitry, based on various parameters exchanged during the attach procedure with its serving eNB, using a protocol called discontinuous reception (DRX). During the DRX period, the UE is still connected to the network and its receiver is turned on periodically to determine if the eNB has sent any packets to it. This thesis develops the concepts of using simulation to demonstrate if a denial of service attack during the long DRX period, as hypothesized by some researchers, can be realized. Requirements for experimentation were identified and current simulation tools were evaluated as potential candidates. The tools applied were the LTE standards, the open source ns-3 network simulator and analysis of actual LTE packet traces. Follow-on studies will be required in order to address issues due to the incompleteness of the ns-3 LTE model and the incompatibility of the file format for LTE traces with that required by the Wireshark network protocol analyzer. Essentially, neither tool contains the DRX algorithm.			
14. SUBJECT TERMS long term evolution, wireless access communications network, discontinuous reception, network simulation, LTE, DRX		15. NUMBER OF PAGES 91	
		16. PRICE CODE	
17. SECURITY CLASSIFICATION OF REPORT Unclassified	18. SECURITY CLASSIFICATION OF THIS PAGE Unclassified	19. SECURITY CLASSIFICATION OF ABSTRACT Unclassified	20. LIMITATION OF ABSTRACT UU

THIS PAGE INTENTIONALLY LEFT BLANK

Approved for public release; distribution is unlimited

**CYBER SECURITY VULNERABILITIES DURING LONG TERM EVOLUTION
POWER-SAVING DISCONTINUOUS RECEPTION PROTOCOL**

Navin Jaffer
Civilian, Department of Homeland Security
B.S., Massachusetts Institute of Technology, 1979

Submitted in partial fulfillment of the
requirements for the degree of

MASTER OF SCIENCE IN CYBER SYSTEMS AND OPERATIONS

from the

**NAVAL POSTGRADUATE SCHOOL
June 2014**

Author: Navin Jaffer

Approved by: John C. McEachen
Thesis Co-Advisor

David A. Garren
Thesis Co-Advisor

Cynthia Irvine
Chair, Department of Cyber Academic Group

THIS PAGE INTENTIONALLY LEFT BLANK

ABSTRACT

Long Term Evolution (LTE) is a wireless access communications network that consists of base stations called eNodeBs (eNBs), which allow connectivity between the mobile device or user equipment (UE) and the core network. To save battery power, the UE can turn off its radio transceiver circuitry, based on various parameters exchanged during the attach procedure with its serving eNB, using a protocol called discontinuous reception (DRX). During the DRX period, the UE is still connected to the network and its receiver is turned on periodically to determine if the eNB has sent any packets to it.

This thesis develops the concepts of using simulation to demonstrate if a denial of service attack during the long DRX period, as hypothesized by some researchers, can be realized. Requirements for experimentation were identified and current simulation tools were evaluated as potential candidates. The tools applied were the LTE standards, the open source ns-3 network simulator and analysis of actual LTE packet traces. Follow-on studies will be required in order to address issues due to the incompleteness of the ns-3 LTE model and the incompatibility of the file format for LTE traces with that required by the Wireshark network protocol analyzer. Essentially, neither tool contains the DRX algorithm.

THIS PAGE INTENTIONALLY LEFT BLANK

TABLE OF CONTENTS

I.	INTRODUCTION.....	1
A.	IMPORTANCE OF LONG TERM EVOLUTION SECURITY VULNERABILITY INVESTIGATIONS.....	1
B.	SCOPE OF THESIS	1
C.	THESIS METHODOLOGY	2
D.	THESIS ORGANIZATION.....	3
II.	LITERATURE REVIEW	5
A.	SUMMARY DESCRIPTION OF LONG TERM EVOLUTION NETWORK ARCHITECTURE.....	5
1.	Radio Protocol Architecture	8
2.	Physical, Logical and Transport Channels.....	11
3.	Physical Downlink Control Channel.....	16
B.	LONG TERM EVOLUTION RADIO NETWORK TEMPORARY IDENTIFIERS.....	17
1.	Cell Radio Network Temporary Identifier.....	20
C.	CONNECTING TO A LONG TERM EVOLUTION NETWORK.....	22
1.	System Information Acquisition.....	22
2.	Bearers	24
3.	Radio Resource Control Protocol.....	25
4.	Random Access Channel Procedure	27
5.	Evolved Packet System Connection Management.....	29
D.	LONG TERM EVOLUTION SECURITY.....	31
1.	Security Architecture.....	31
2.	Access Stratum Security.....	33
E.	LONG TERM EVOLUTION DISCONTINUOUS RECEPTION PROTOCOL.....	35
1.	Short and Long Discontinuous Reception Cycles	36
2.	Connected State.....	37
3.	Idle State	37
4.	User equipment Feature Group Indicators	38
5.	Medium Access Control Protocol Layer.....	39
F.	RELATED WORK IN LONG TERM EVOLUTION SECURITY VULNERABILITIES DURING DISCONTINUOUS RECEPTION PERIOD	42
III.	METHODOLOGY	45
A.	DESCRIPTION OF NS-3 OPEN SOURCE NETWORK SIMULATOR.....	45
B.	DESCRIPTION OF THE LENA MODULE IN NS-3.....	45
C.	USER EQUIPMENT DISCONTINUOUS RECEPTION PERIOD ALGORITHM.....	54
IV.	RESULTS	55

A.	NS-3 LENA MODEL SIMULATOR LIMITATIONS.....	55
B.	LIMITATIONS OF LONG TERM EVOLUTION TRACES.....	56
V.	CONCLUSIONS AND FUTURE WORK.....	59
A.	CONCLUSIONS.....	59
B.	FUTURE WORK.....	60
	LIST OF REFERENCES.....	63
	INITIAL DISTRIBUTION LIST.....	67

LIST OF FIGURES

Figure 1.	Network solutions from GSM to LTE (from [8]).....	5
Figure 2.	Circuit and packet domains (from [9]).....	6
Figure 3.	Basic EPS architecture (from [9]).....	7
Figure 4.	3GPP and non-3GPP access networks (from [9]).....	7
Figure 5.	General protocol model for E-UTRAN interfaces (from [11]).....	8
Figure 6.	E-UTRAN Protocol Stack (from [12])	9
Figure 7.	LTE control plane protocol stacks (from [10]).....	10
Figure 8.	LTE user plane protocol stacks (from [10]).....	10
Figure 9.	Time domain view of the LTE downlink data flow (from [4]).....	11
Figure 10.	Downlink channel mapping (from [16]).....	16
Figure 11.	Uplink channel mapping (from [16]).....	16
Figure 12.	Uses of LTE Identifiers (from [18]).....	18
Figure 13.	EPS Bearer Service Architecture (from [19]).....	25
Figure 14.	PDN connection and EPS bearer (from [24])	25
Figure 15.	Contention-based RACH Procedure (from [25]).....	28
Figure 16.	EMM and ECM state transitions (from [26])	31
Figure 17.	Overview of the security architecture (from [7]).....	32
Figure 18.	Establishment of NAS and AS security contexts during initial attach (from [27]).....	34
Figure 19.	EPS DRX connection modes and states (from [29])	35
Figure 20.	DRX Cycles and Timing (from [22]).....	36
Figure 21.	Bits 4 and 5 of UE Feature Group Indicators (from [31])	38
Figure 22.	MAC protocol data unit (from [16])	39
Figure 23.	MAC Random access response (from [16]).....	39
Figure 24.	Example of MAC PDU (from [16]).....	41
Figure 25.	Values of LCID for DL-SCH (from [16]).....	41
Figure 26.	Values of LCID for UL-SCH (from [16]).....	41
Figure 27.	Denial of service attack using C-RNTI (from [5]).....	43
Figure 28.	Successful Packet Injection Attack (from [5]).....	44
Figure 29.	Overview of the LTE-EPC simulation model (from [34]).....	46
Figure 30.	LTE radio protocol stack model for UE on the data plane (from [34])	47
Figure 31.	LTE radio protocol stack model for UE on the control plane (from [34])	48
Figure 32.	LTE PHY and channel model architecture for UE (from [34])	48
Figure 33.	LTE radio protocol stack architecture for eNB on the data plane (from [34]).....	49
Figure 34.	LTE radio protocol stack architecture for eNB on the control plane (from [34]).....	50
Figure 35.	LTE PHY and channel model architecture for eNB (from [34])	50
Figure 36.	LTE-EPC data plane protocol stack in LENA model (from [34]).....	51
Figure 37.	EPC control plane model (from [34])	52
Figure 38.	LTE sub-frame in LENA (from [34])	53

THIS PAGE INTENTIONALLY LEFT BLANK

LIST OF TABLES

Table 1.	Logical control and traffic channels provided by the MAC (after [16]).....	12
Table 2.	Physical transport channels used by the MAC (after [16]).....	13
Table 3.	Physical control and data channels (after [16]).....	14
Table 4.	Transport processor physical channel control information and channels (after [16]).....	15
Table 5.	Supported PDCCH formats (from [14])	17
Table 6.	Description of LTE identifiers (from [18]).....	20
Table 7.	RNTI values (from [16]).....	21
Table 8.	RNTI usage (from [16])	21
Table 9.	Some of the contents of SIB1 (after [23]).....	23
Table 10.	Some of the contents of SIB2 (after [23]).....	24
Table 11.	Characteristics of RRC protocol states (after [19]).....	27
Table 12.	Security Termination Points (from [19])	32
Table 13.	DRX parameters (after [16]).....	40
Table 14.	User equipment DRX pseudo-code (from [35])	54

THIS PAGE INTENTIONALLY LEFT BLANK

LIST OF ACRONYMS AND ABBREVIATIONS

2G	second generation
3G	third generation
3GPP	Third Generation Partnership Project
4G	fourth generation
AAA	authentication, authorization and accounting
AKA	authentication and key agreement
APN	access point name
AS	access stratum or access layer
BCH	broadcast channel
BCCH	broadcast control channel
BS	base station
CCCH	common control channel
CCE	control channel elements
CDMA	code division multiple access
CDMA2000	family of 3G mobile technology standards that use CDMA
C-PDU	control protocol data unit
CFI	control format indicator
CP	cyclic prefix
C-RNTI	cell radio network temporary identifier
CS	circuit switching
DCCH	dedicated control channel
DCI	downlink control information
DL	downlink or transmission path from eNB to the UE
DL-SCH	downlink shared channel
DoS	denial of service
D-PDU	data protocol data unit
DRB	data radio bearer
DRX	discontinuous reception
DTCH	dedicated traffic channel
DTX	discontinuous transmission

DSCP	DiffServ code point
ECM	EPS connection management
EDGE	enhanced data rates for global evolution
EMM	EPS mobility management
eNB	base station called evolved NodeB or eNodeB in LTE
EPC	evolved packet core
ePDG	evolved packet data gateway
EPS	evolved packet system
E-RAB	E-UTRAN radio access bearer
E-UTRA	evolved UMTS terrestrial radio access
E-UTRAN	evolved UMTS terrestrial radio access network
FAPI	femto application platform interface
FDD	frequency division duplexing
FFT	fast Fourier transform
FGI	feature group indicators
GBR	guaranteed bit rate
GERAN	GSM EDGE radio access network
GPRS	general packet radio service
GPS	global positioning system
GSM	Global System of Mobile Communications
GTP	GPRS tunneling protocol
HARQ	hybrid automatic repeat-request
HI	hybrid ARQ indicator
HSPA	high speed packet access
HSS	home subscriber server
Hz	Hertz, a unit of frequency defined as one cycle per second
IMS	IP multimedia subsystem
IMT-Advanced	International Mobile Telecommunications Advanced
IP	Internet Protocol
IPsec	Internet Protocol security
ISI	inter symbol interference
ITU	International Telecommunications Union

LCID	logical channel ID
LTE	Long Term Evolution
LTE-A	LTE advanced
MAC	medium access control protocol
MCH	multicast channel
MCCH	multicast control channel
MIB	master information block
MBMS	multimedia broadcast/multicast service
MME	mobility management entity
MPLS	multiprotocol label switching
MS	mobile station
MTCH	multicast traffic channel
Node B	equivalent to the BTS (base transceiver station) in UMTS
NAS	non-access stratum or layer
NPS	Naval Postgraduate School
OFDM	orthogonal frequency-division multiplexing
OFDMA	orthogonal frequency division multiple access
PAPR	peak-to-average power ratio
PBCH	physical broadcast channel
PCH	paging channel
PCCH	paging control channel
PCFICH	physical control format indicator channel
PCI	physical cell identification
PDCCH	physical downlink control channel
PDSCH	physical downlink shared channel
P-GW	packet data network gateway or PDN-GW or PGW
PHICH	physical HARQ indicator channel
PDCP	packet data convergence protocol
PDN	packet data network
PDU	protocol data unit
PHY	physical layer
PLMN	public land mobile network

PMCH	physical multicast channel
PRACH	physical random access channel
PS	packet switching
PSS	primary synchronization signal
PUCCH	physical uplink control channel
PUSCH	physical uplink shared channel
QAM	quadrature amplitude modulation
QoS	quality of service
QCI	QoS class identifier
QPSK	quadrature phase shift keying
RAB	radio access bearer
RACH	random access channel
RAN	radio access network
RA-RNTI	radio network temporary identity
RAT	radio access technology
RB	resource block composed of several resource elements
RE	resource element of 15 kHz subcarrier by one symbol in LTE
REG	resource element group composed of four physical RE
RF	radio frequency
RLC	radio link control protocol
RNTI	radio network temporary identifier
RRC	radio resource control protocol
RSSI	received signal strength indication
SAE	system architecture evolution
SC-FDMA	single carrier frequency division multiple access
SDU	service data unit
SFN	system frame number
S-GW	serving gateway or SGW
SI	system information
SIB	system information block
SIB#	system information block type #
SRB	signaling radio bearer

SI-RNTI	system information RNTI
SS	subscriber station
SSS	secondary synchronization signal
TCP	transmission control protocol
TDD	time division duplexing
TDMA	time division multiple access
TFT	traffic flow templates
TMSI	temporary mobile subscriber identity
UCI	uplink control information
UDP	user datagram protocol
UE	user equipment, sometimes called mobile equipment
UL	uplink transmission path from the UE to the eNB
UL-SCH	uplink shared channel
UMTS	Universal Telecommunications System
UTRA	Universal Terrestrial Radio Access
UTRAN	universal terrestrial radio access network
VoIP	voice over Internet Protocol
WCDMA	wideband code division multiple access
WiMAX	worldwide interoperability for microwave access
WLAN	wireless local area network

THIS PAGE INTENTIONALLY LEFT BLANK

EXECUTIVE SUMMARY

The United States government's goal of delivering information and services to the American people, as well as ensuring their defense and safety, depends heavily on mobile technology. The government is planning on using the high bandwidth and efficiency of the wireless communications technology called Long Term Evolution (LTE) to achieve that goal.

Most researchers have focused on improving LTE's performance and efficiency for the past ten years and have only recently started investigating the security vulnerabilities of LTE. The development of the LTE standards have taken into account the security deficiencies of prior generations of wireless communications technologies, but some researchers have theorized cyber attacks could still occur in LTE during times when those security protocols are inactive or weak. The specific vulnerabilities in LTE often mentioned include illegal use of user and mobile equipment, location tracking, denial of service attacks, and data integrity attacks. However, none of the researchers has provided any experimental data to support the claims of such vulnerabilities.

It is hypothesized that if one obtains the user identity information sent in the clear during network attach, it could then be used to conduct a denial of service or data integrity attack during the long-term power saving mode. Analysis of LTE standards has revealed that the user's equipment can be vulnerable to a cyber attack during the network attach mode, or during the long term power saving mode, because security protocols are either inactive or weak.

The open source ns-3 network simulator was investigated as a tool, but it was found that the LTE model was incomplete and did not include the complete medium access control protocol header or the data unit and the power saving algorithm. Next, analysis of captured LTE packet traces available at the Naval Postgraduate School (NPS) was considered. The Wireshark network protocol analyzer tool indicates a capability to decode the LTE medium access control, radio link control and packet data convergence protocol headers, if LTE packet traces are captured using the dissectors for those headers.

However, the NPS LTE packet traces available were not in the libpcap file format required by Wireshark and the power saving algorithm was not in effect when the traces were recorded by a different commercial software package. As a result, it was not possible to analyze if the security protocols were weak during the attach procedure or during the power saving mode.

The LTE standards have parameters defined for a power saving algorithm but do not specify how to implement the algorithm. In fact, very few device vendors have implemented a power saving algorithm, though many currently have plans to do so in the future. Appropriate laboratory testing equipment and software for analyzing LTE signals are required to demonstrate a cyber attack in LTE, both of which were not available at the time of this thesis.

ACKNOWLEDGMENTS

I would like to thank my advisors, Dr. McEachen and Dr. Garren, for their guidance throughout the thesis process.

THIS PAGE INTENTIONALLY LEFT BLANK

I. INTRODUCTION

A. IMPORTANCE OF LONG TERM EVOLUTION SECURITY VULNERABILITY INVESTIGATIONS

The *Digital Government Strategy* was released on May 23, 2012 [1] with the goal of delivering “digital government information and services anywhere, anytime, on any device.” Mobile technology is a big part of that strategy. The “Department of Defense Mobile Device Strategy,” released in June 2012, focuses on wireless infrastructure, mobile devices and mobile applications to advance operational effectiveness [2]. The 700 megahertz (MHz) public safety band comprises 24 MHz of spectrum designated for public safety use. In its *Third Report and Order*, the Federal Communications Commission “codified the requirement that 700 MHz public safety broadband network operators adopt the” Third Generation Partnership Project (3GPP) Release 8 Long Term Evolution (LTE) “or higher as a common technology platform” [3]. Most cellular service providers have plans to migrate their current cellular technology to LTE. However, little research has been done to date into the security vulnerabilities of LTE because most researchers have been focused on improving its performance and efficiency.

B. SCOPE OF THESIS

LTE is an access communications network of base stations called eNodeBs (eNBs) that allow connectivity between the mobile devices or user equipment (UE) and the core network. To save battery power, the UE can turn off its radio transceiver circuitry, based on various parameters exchanged during the attach procedure with its serving eNB, using a protocol called Discontinuous Reception (DRX). The radio is optimized for performance on the downlink from the network to the UE because the transmitter at the base station is assumed to have plenty of power [4]. Although processing power has increased, mobile device battery power has stayed essentially constant, resulting in the optimization of the UE radio for power consumption instead of efficiency on the uplink to the eNB. During the DRX period, the UE is still connected to the network and its receiver is turned on periodically to determine if the eNB has sent any packets to it using paging and if it should become active.

The development of the 3GPP LTE standards has taken into account the security deficiencies of prior generations of wireless communications technologies. It has been suggested in some LTE security research papers that the long DRX period is one of several potential security vulnerabilities in LTE [5], [6]. It is hypothesized that if one obtains the user identity information sent in the clear during network attach, it could then be used to conduct a denial of service or data integrity attack during the long DRX period. However, no research has been conducted to confirm such an exploit and to determine network properties that make the DRX protocol vulnerable to cyber attacks given LTE's enhanced security protocols.

This thesis investigates if it is possible to demonstrate a denial of service (DoS) attack during the LTE power-saving long DRX period using analysis and simulation. Specifically, it will investigate if an attacker could obtain the Cell Radio Network Temporary Identifier (C-RNTI) of a UE and use it during the long DRX period to prevent the UE from communicating with the network. The C-RNTI is a unique and temporary UE identifier given by the serving eNB to identify one specific radio channel from another radio channel and one user from another user within the cell. A primary benefit of the study would be to identify the conditions under which such an attack is possible and to determine potential mitigation solutions.

C. THESIS METHODOLOGY

In order to determine the specific properties of the long DRX period that makes LTE vulnerable, it is necessary to examine the radio resource control (RRC) protocols and algorithms used during establishment and periodic maintenance of the connection between the UE and the network. It is also important to examine the state of the mutual authentication between the UE and eNB during the long DRX period.

This study will identify the requirements for investigating DRX vulnerabilities in LTE and evaluate the use of the open source ns-3 network simulator. The study will not investigate how to circumvent the five security levels in LTE developed by 3GPP [7].

D. THESIS ORGANIZATION

Investigation of the 3GPP LTE standards relevant for attaching to a network, security establishment and maintenance of the connection are in Section II. Detailed information on the RRC and DRX protocols is analyzed. The state of the connection and what triggers the DRX period are examined. The types of LTE radio network temporary identifiers used during a connection are explored. In addition, prior work in LTE security vulnerabilities during the DRX period is summarized.

Section III describes the thesis methodology, including the open source ns-3 network simulator and the LTE module within it. Section IV discusses the results of the thesis. Finally, conclusions and recommendations for further research are discussed in Section V.

THIS PAGE INTENTIONALLY LEFT BLANK

II. LITERATURE REVIEW

A. SUMMARY DESCRIPTION OF LONG TERM EVOLUTION NETWORK ARCHITECTURE

LTE is a fourth generation (4G) wireless communications network whose standards were first developed by the 3GPP in 2004. LTE is designed to improve upon the reliability, bandwidth limitations and security vulnerabilities of older cellular technologies such as Global System for Mobile Communications (GSM), general packet radio service (GPRS), Universal Mobile Telecommunications System (UMTS), code division multiple access (CDMA) and high speed packet access (HSPA) [8]. Most cellular wireless systems consist of a radio access network (RAN) and a core network as shown in Figure 1. The LTE core network is called the evolved packet core (EPC). The LTE access stratum (AS) network consists of coordinating base stations, known as eNBs, which allow connectivity between the mobile devices or UE and the EPC. The access network of eNBs is also known as the evolved UMTS terrestrial radio access (E-UTRA) or evolved UMTS terrestrial radio access network (E-UTRAN). The evolved packet system (EPS) is composed of the E-UTRAN and the EPC.

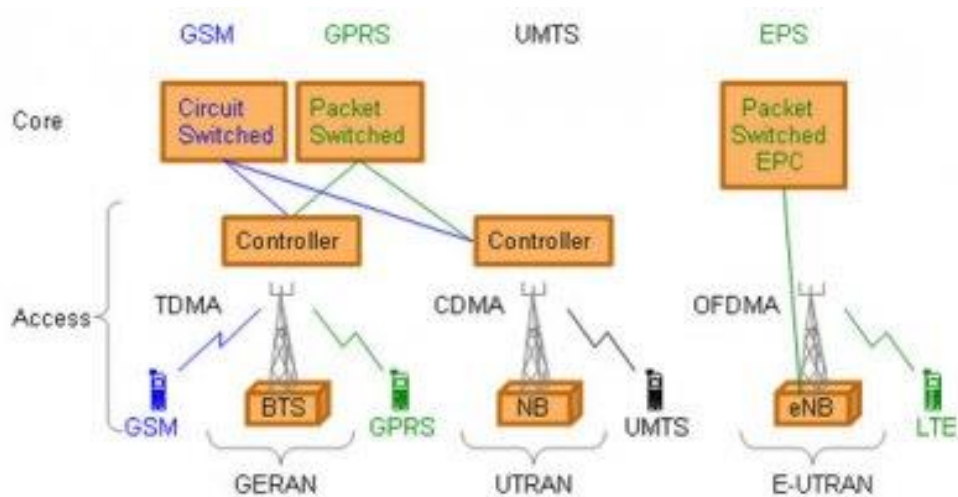

Figure 1. Network solutions from GSM to LTE (from [8])

The 3GPP community made many decisions that have affected the architecture of the LTE network [9]. Internet Protocol (IP) is used to transport all services in LTE for routing efficiency, which means each network functional element or network node requires an IP address. The use of a “flat architecture” means that few network nodes are involved in the handling of the traffic and protocol conversion is avoided. The user data (user plane) is separated from the signaling (control plane) to make the scaling of one independent from the other. The EPC is an evolution of the packet-switched architecture used in third generation (3G) cellular technologies instead of the circuit-switched architecture used in second generation (2G) cellular technologies, as shown in Figure 2. In circuit-switching (CS), dedicated circuits are established between the calling and called parties from source to destination in the telecommunication network. With packet-switching (PS), data is transported in packets without the establishment of dedicated circuits and bandwidth is shared.

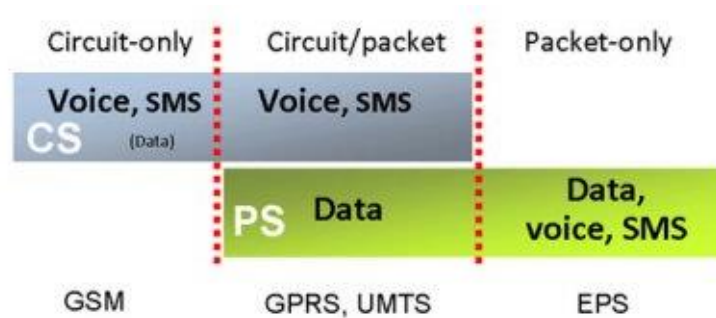

Figure 2. Circuit and packet domains (from [9])

The EPC is made up of subcomponents such as the mobility management entity (MME) for the control plane, the serving gateway (S-GW) and packet data network gateway (P-GW) for the user plane, and the home subscriber server (HSS) as shown in Figure 3. The EPC is linked to the external internet, private corporate or the IP multimedia subsystem (IMS) networks. The MME handles the control plane signaling related to UE mobility, security for E-UTRAN access, and the tracking and paging of the UE in idle mode. The MME also maintains context information for UEs in various states [10]. The HSS is a database that contains user-related and subscriber-related information. It also provides support functions in mobility management, call and session setup, as well

as user authentication, authorization and accounting (AAA) functions. The S-GW and P-GW transport the user plane IP data traffic between the UE and the external networks. The S-GW serves the UE by routing the incoming and outgoing IP packets. The P-GW is selected from access point name (APN) parameters provided by the UE or service operator. The P-GW routes packets from the EPC to the external IP and IMS networks using the IP address allocated to the UE during the attach procedure. Transport is through IP and multiprotocol label switching (MPLS) backbone networks.

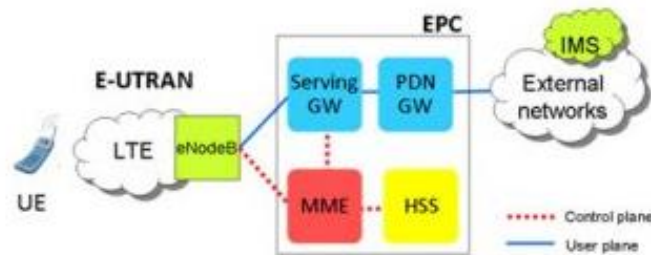

Figure 3. Basic EPS architecture (from [9])

3GPP specifications define how 3GPP and non-3GPP radio access networks can connect with each other as shown in Figure 4 [9]. The network service operator can split non-3GPP accesses into two categories. Trusted non-3GPP accesses can interact directly with the EPC. Untrusted non-3GPP accesses use an evolved packet data gateway (ePDG) to interact with the EPC.

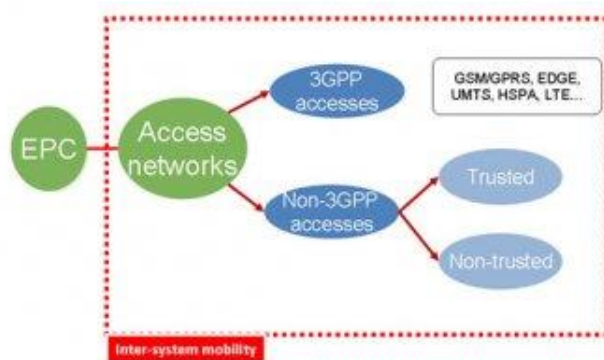

Figure 4. 3GPP and non-3GPP access networks (from [9])

1. Radio Protocol Architecture

The LTE radio protocol architecture consists of the logically independent control and user planes, both of which are separated into a logically independent radio network layer and a transport network layer [11] as shown in Figure 5. The user plane contains application data packets processed by protocols such as transmission control protocol (TCP), user datagram protocol (UDP) and IP [12]. The control plane sends signaling messages to control network access connections between the UE and the core network, or the UE and the access network, and user resources. The control plane establishes the user plane with the desired quality of service (QoS).

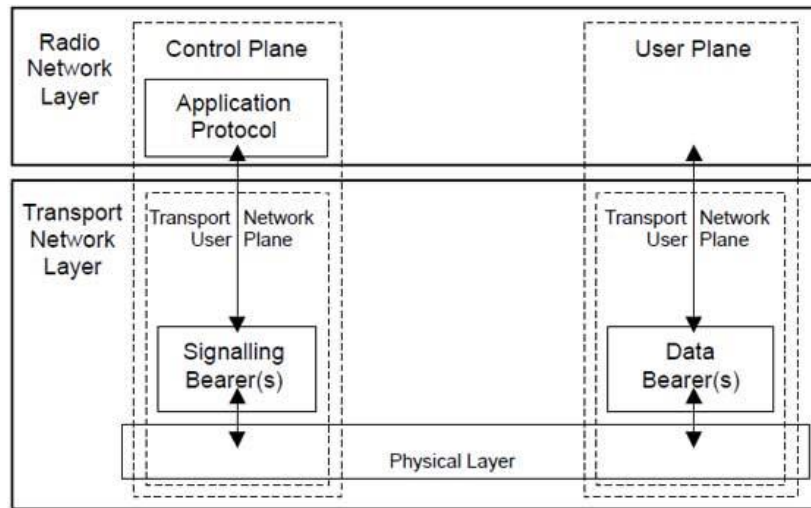

Figure 5. General protocol model for E-UTRAN interfaces (from [11])

The layers of the E-UTRAN protocol stack can be seen in Figure 6. A packet received by a layer is called a service data unit (SDU) and a packet output from a layer is called a protocol data unit (PDU). In both the user and control planes, the information is processed by the packet data convergence protocol (PDCP), the radio link control (RLC) protocol, the medium access control (MAC) protocol and the physical layer (PHY). The LTE PHY is usually full duplex. The MAC layer determines how to use the transport channels, how to pack the information in it, and what modulation and coding to configure the PHY layer with for the correct transmit data rate [4]. When a UE is powered on, it initiates an attach procedure to register with an eNB in the access network using the RRC

protocols, and to register with the MME in the core network using the non-access stratum (NAS) protocols. The downlink flow progresses upward and uplink flow progresses downward through the layers shown in Figure 6.

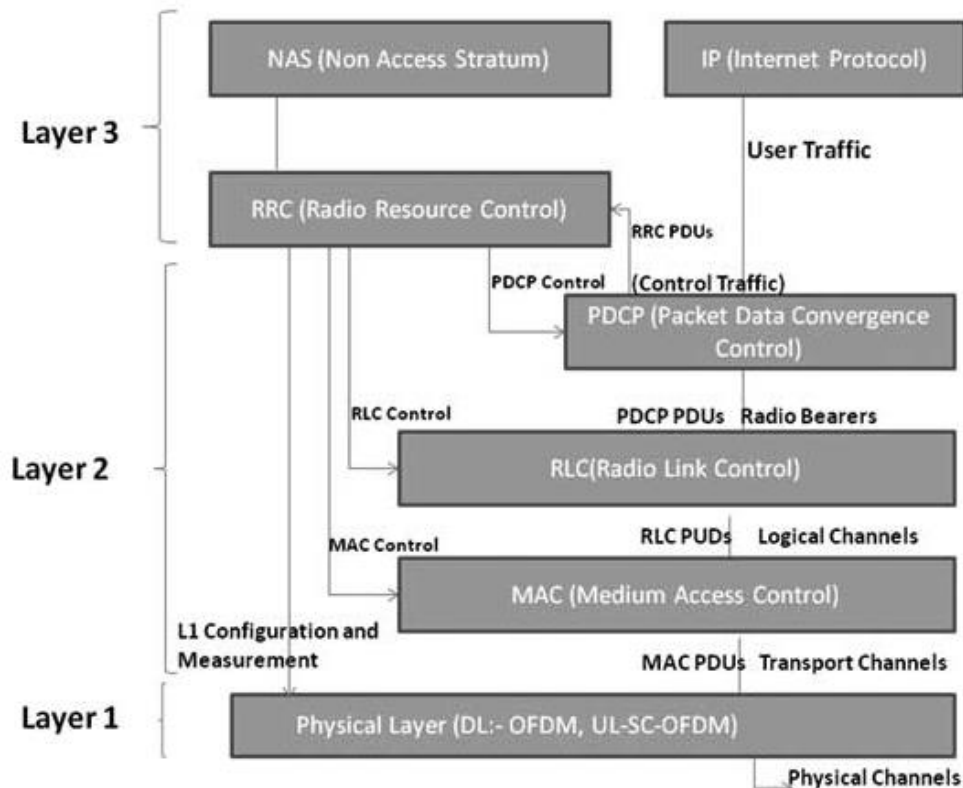

Figure 6. E-UTRAN protocol stack (from [12])

The control plane protocol stack functions are shown in Figure 7. The NAS protocol is used for non-radio communication between the UE and the core network MME after attachment. The NAS protocol performs authentication, registration, bearer context activation and deactivation, as well as location registration management [13]. The RRC protocol is used to exchange the control plane signaling messages in the AS between the eNB and the UE [12]. In the uplink, the UE MAC coordinates measurements from the PHY to the RRC about UE status and local conditions, and the RRC communicates with the eNB using control messages. In the downlink from the eNB to the UE, the RRC controls the PHY modulation and configuration settings. The MME can communicate with the eNB through the S1-AP signaling interface protocol.

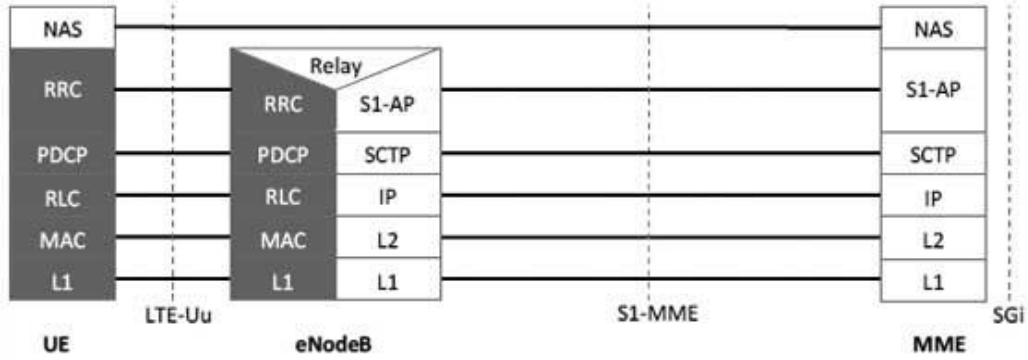

Figure 7. LTE control plane protocol stacks (from [10])

The user plane protocol stack functions between the eNB and UE are shown in Figure 8. In the user plane, packets are encapsulated and tunneled between the P-GW and the eNB using different tunneling protocols depending on the logical interface [12]. The GPRS tunneling protocol (GTP) is used for the S1 interface between the eNB and S-GW, and the S5/S8 interface between the S-GW and P-GW. S5 is used if the two devices are in the same network, and S8 is used if they are in different networks. GTP is used to encapsulate user data transported through the core network and also carries UE specific signaling traffic between various core networks.

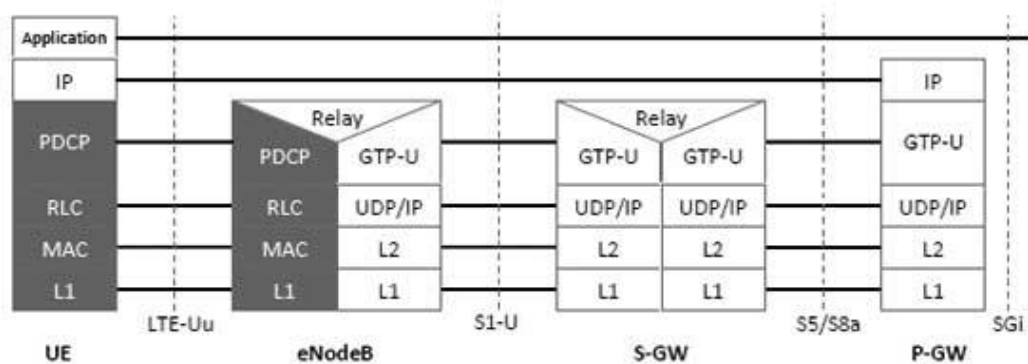

Figure 8. LTE user plane protocol stacks (from [10])

A logical diagram of E-UTRAN protocol layers with data flow in the downlink from network to UE is shown in Figure 9. The duration of each time slot is 0.5 milliseconds (ms), each sub-frame is two slots, and each radio frame contains 10 sub-

frames. Each sub-frame is also known as the transmission time interval. An uplink or downlink physical channel corresponds to a set of resource elements (RE) carrying information originating from the higher layers [14]. Each RE is uniquely defined by an index pair in a time slot of a sub-frame.

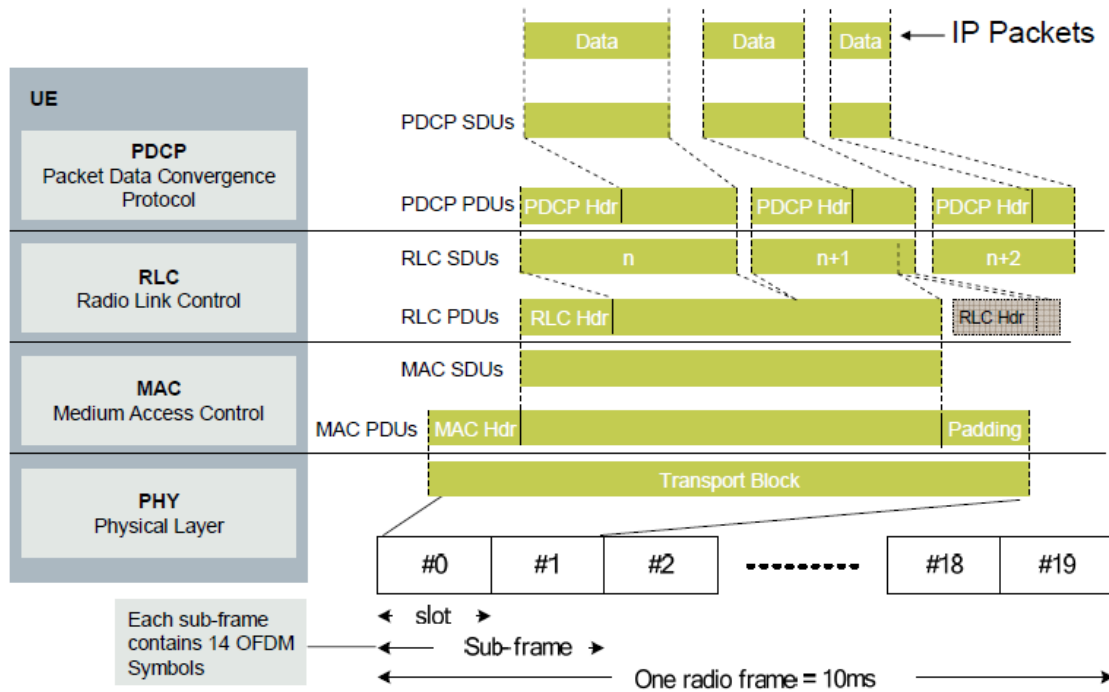

Figure 9. Time domain view of the LTE downlink data flow (from [4])

2. Physical, Logical and Transport Channels

UE and functional entities must be explicitly allocated uplink and downlink non-overlapping resources to send and receive LTE duplex traffic. Data and signaling messages are carried on different types of logical or transport or physical channels depending on the kind of information they carry between the layers and by the way in which the information is processed. A common shared channel is used for all users in a cell (point to multipoint), whereas dedicated channels are used to communicate with only one user (point to point). The RLC layer passes data to the MAC layer as logical channels defined in Table 1 [15]. The MAC layer formats and sends the logical channel data to the physical layer as transport channels defined in Table 2. The physical layer encodes the

transport channel data to the physical channels defined in Table 3. Table 4 shows the control information created by the transport channel processor to support the low-level operation of the PHY and the physical control channels used to send this information.

Channel Name	Acronym	Control channel	Traffic channel	Downlink	Uplink	Usage
broadcast control channel	BCCH	X		X		For broadcasting system control information
paging control channel	PCCH	X		X		For paging when the network does not know the location cell of the UE or to provide system information change notifications
common control channel	CCCH	X		X	X	For transmitting control information between a network and UEs having no RRC connection
dedicated control channel	DCCH	X		X	X	For transmitting dedicated control information bi-directionally between a network and a UE having an RRC connection
dedicated traffic channel	DTCH		X	X	X	For the transfer of user information, dedicated to one UE
multicast control channel	MCCH	X		X		For transmitting point-to-multipoint control information from the network to the UEs that receive multimedia broadcast multicast service (MBMS)
multicast traffic channel	MTCH		X	X		For transmitting point-to-multipoint traffic data from the network to the UEs that receive MBMS

Table 1. Logical control and traffic channels provided by the MAC (after [16])

Channel Name	Acronym	Downlink	Uplink	Usage
broadcast channel	BCH	X		Broadcasts in the entire coverage area of the cell. Uses fixed, pre-defined format.
downlink shared channel	DL-SCH	X		Supports DRX to enable UE power saving. Supports hybrid automatic repeat-request (HARQ). Supports dynamic link adaptation by varying the modulation, coding and transmit power. Supports MBMS transmission. Optionally supports broadcast in the entire cell. Optionally supports beam forming. Supports both dynamic and semi-static resource allocation.
paging channel	PCH	X		Supports DRX to enable UE power saving. Broadcasts in the entire coverage area of the cell. Mapped to physical resources which can be used dynamically also for traffic/other control channels.
multicast channel	MCH	X		Broadcasts in the entire coverage area of the cell. Supports multicast-broadcast single-frequency network (MBSFN) combining of MBMS transmission on multiple cells, semi-static resource allocation.
uplink shared channel	UL-SCH		X	Supports dynamic link adaptation by varying the transmit power and potentially modulation and coding. Supports HARQ. Supports dynamic and semi-static resource allocation. Optional support for beam forming.
random access channel	RACH		X	Carries minimal information from UE and transmissions may be lost due to collisions

Table 2. Physical transport channels used by the MAC (after [16])

Channel Name	Acronym	Downlink	Uplink	Usage
physical broadcast channel	PBCH	X		Within a 40 ms interval, broadcasts a limited number of parameters essential for initial access of the cell (downlink system bandwidth, the physical HARQ indicator channel structure, and the most significant eight-bits of the system frame number) in a master information block (MIB) which is 14 bits long.
physical downlink shared channel	PDSCH	X		Carries the DL-SCH and PCH. Quadrature phase shift keying (QPSK), 16-QAM (quadrature amplitude modulation), and 64-QAM modulation
physical downlink control channel	PDCCH	X		Informs the UE about the resource allocation of PCH and DL-SCH, and HARQ information related to DL-SCH. Carries the uplink scheduling grant. QPSK modulation.
physical multicast channel	PMCH	X		Carries the MCH QPSK, 16-QAM, and 64-QAM modulation
physical uplink shared channel	PUSCH		X	Carries the UL-SCH QPSK, 16-QAM, and 64-QAM modulation
physical uplink control channel	PUCCH		X	Carries HARQ, positive acknowledgments (ACKs) or negative acknowledgments (NACKs) in response to downlink transmission, scheduling request (SR), channel quality indicators (CQI) reports. Binary phase shift keying (BPSK) and QPSK modulation.
physical random access channel	PRACH		X	Carries the random access preamble a UE uses to access the network in non-synchronized mode and allow the UE to synchronize timing with the eNB

Table 3. Physical control and data channels (after [16])

Field Name	Acronym	Downlink	Uplink	Usage
downlink control information	DCI	X		Contains transmission resource assignments and other control information (i.e., power, HARQ) for a UE or group of UEs
control format indicator	CFI	X		32-bit long CFI is mapped to 16 RE in the first orthogonal frequency-division multiplexing (OFDM) symbol of each downlink frame
hybrid ARQ indicator	HI	X		The eNB sends to the UE an ACK (111) or NACK (000) for data sent using the UL-SCH.
uplink control information	UCI		X	Contains SR, HARQ ACK/NACK, CQI
physical control format indicator channel	PCFICH	X		Carries the CFI used to dynamically indicate the number of symbols to be used for PDCCH
physical HARQ indicator channel	PHICH	X		Carries HARQ ACK/NAKs in response to uplink transmissions which indicates to the UE whether the eNB correctly received uplink user data carried on the PUSCH. QPSK modulation.

Table 4. Transport processor physical channel control information and channels (after [16])

The mapping between the logical, physical and transport channels for the downlink can be seen in Figure 10. In the uplink, the common control channel (CCCH), dedicated control channel (DCCH) and dedicated traffic channel (DTCH) are all mapped to the uplink shared channel (UL-SCH) as shown in Figure 11 [4].

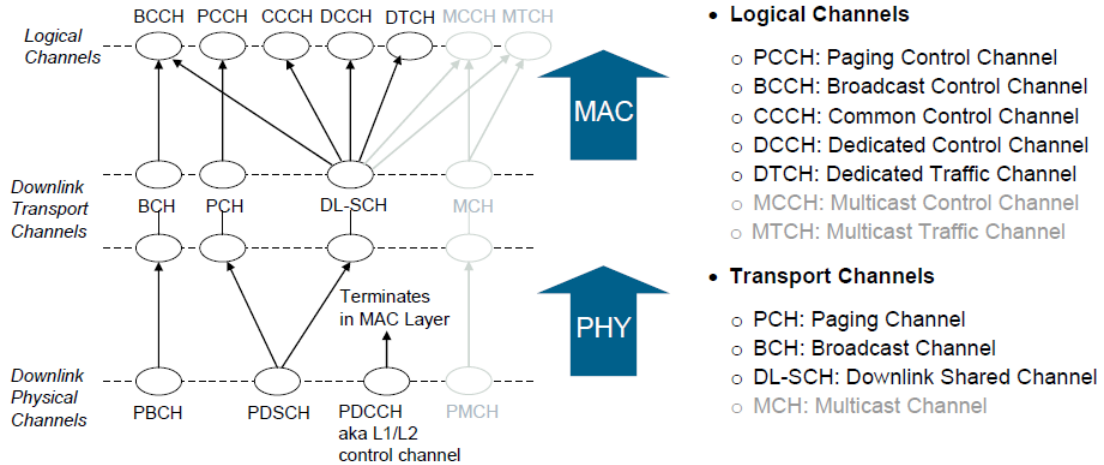

Figure 10. Downlink channel mapping (from [16])

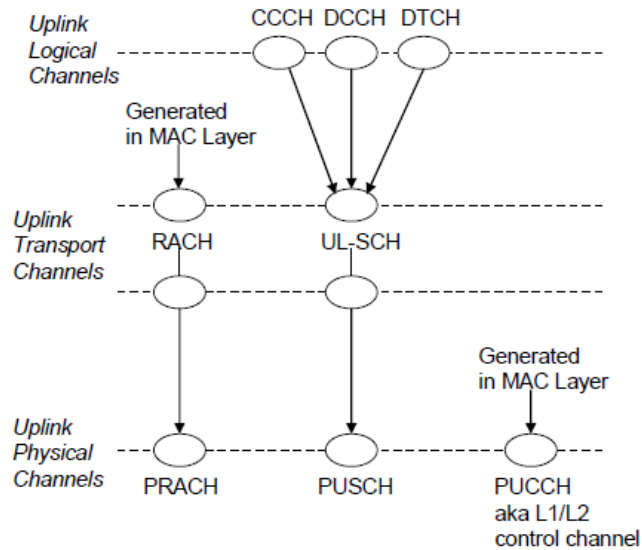

Figure 11. Uplink channel mapping (from [16])

3. Physical Downlink Control Channel

All MAC transmissions on the UL-SCH must be scheduled by the random access channel (RACH) procedure. The physical downlink shared channel (PDSCH) carries all user data and all multi-cast signaling messages. The physical downlink control channel (PDCCH) carries the layer one downlink control information (DCI) message that indicates who the data is for, as well as the type and format of data transmitted [17].

There can be four PDCCH formats each of which has a set number of control channel elements (CCE) as shown in Table 5 [14]. Each CCE is composed of nine resource element groups (REG), and each REG is composed of four physical resource elements (RE). Multiple PDCCHs can be transmitted in a sub-frame by the eNB. The physical control format indicator channel (PCFICH) carries information about the number of orthogonal frequency-division multiplexing (OFDM) symbols used for transmission of PDCCHs in a sub-frame.

PDCCH format	Number of CCE	Number of REG	Number of PDCCH bits
0	1	9	72
1	2	18	144
2	4	36	288
3	8	72	576

Table 5. Supported PDCCH formats (from [14])

The eNB can use one of many defined DCI formats based on the transmission mode and the type of radio network temporary identifiers (RNTI) for the associated PDCCH. Since the location of a specific PDCCH and type of DCI can vary based on whether it is for a specific UE or a shared broadcast, the UE needs to search all the possible locations in the frame for it and conduct a blind decoding of the PDCCH.

B. LONG TERM EVOLUTION RADIO NETWORK TEMPORARY IDENTIFIERS

There are many types of radio network temporary identifiers (RNTI) used in the LTE network as shown in Figure 12 and details of each one are given in Table 6.

IMSI	International Mobile Subscriber Identity	<ul style="list-style-type: none"> Unique identification of mobile (LTE) subscriber Network (MME) gets the PLMN of the subscriber 	IMSI (not more than 15 digits) = PLMN ID + MSIN = MCC + MNC + MSIN	P
PLMN ID	Public Land Mobile Network Identifier	<ul style="list-style-type: none"> Unique identification of PLMN 	PLMN ID (not more than 6 digits) = MCC + MNC	P
MCC	Mobile Country Code	<ul style="list-style-type: none"> assigned by ITU 	3 digits	P
MNC	Mobile Network Code	<ul style="list-style-type: none"> assigned by National Authority 	2~3 digits	P
MSIN	Mobile Subscriber Identification Number	<ul style="list-style-type: none"> assigned by operator 	9~10 digits	P
GUTI	Globally Unique Temporary UE Identity	<ul style="list-style-type: none"> To identify a UE between the UE and the MME on behalf of IMSI for security reason 	GUTI (not more than 80 bits) = GUMMEI + M-TMSI	T
TIN	Temporary Identity used in Next Update	<ul style="list-style-type: none"> GUTI is stored in TIN parameter of UE's MM context. TIN indicates which temporary ID will be used in the next update 	TIN = GUTI	T
S-TMSI	SAE Temporary Mobile Subscriber Identity	<ul style="list-style-type: none"> To locally identify a UE in short within a MME group (Unique within a MME Pool) 	S-TMSI (40 bits) = MMEC + M-TMSI	T
M-TMSI	MME Mobile Subscriber Identity	<ul style="list-style-type: none"> Unique within a MME 	32 bits	T
GUMMEI	Globally Unique MME Identity	<ul style="list-style-type: none"> To identify a MME uniquely in global GUTI contains GUMMEI 	GUMMEI (not more than 48 bits) = PLMN ID + MMEI	P
MMEI	MME Identifier	<ul style="list-style-type: none"> To identify a MME uniquely within a PLMN Operator commissions at eNB 	MMEI (24 bits) = MMEGI + MMEC	P
MMEGI	MME Group Identifier	<ul style="list-style-type: none"> Unique within a PLMN 	16 bits	P
MMEC	MME Code	<ul style="list-style-type: none"> To identify a MME uniquely within a MME Group. S-TMSI contains MMEC 	8 bits	P
C-RNTI	Cell- Radio Network Temporary Identifier	<ul style="list-style-type: none"> To identify an UE uniquely in a cell 	0x0001 ~ 0xFFFF3 (16 bits)	T
eNB S1AP UE ID	eNB S1 Application Protocol UE ID	<ul style="list-style-type: none"> To uniquely identify UE on S1- MME Interface in eNB 	32-bit Integer (0 .. 2 ³² - 1)	T
MME S1AP UE ID	MME S1 Application Protocol UE ID	<ul style="list-style-type: none"> To uniquely identify UE on S1- MME Interface in MME 	32-bit Integer (0 .. 2 ³² - 1)	T
IMEI	International Mobile Equipment Identity	<ul style="list-style-type: none"> To identify a ME (Mobile Equipment) uniquely 	IMEI (15 digits) = TAC + SNR + CD	P
IMEI/SV	IMEI/Software Version	<ul style="list-style-type: none"> To identify a ME (Mobile Equipment) uniquely 	IMEI/SV (16 digits) = TAC + SNR + SVN	P
ECGI	E-UTRAN Cell Global Identifier	<ul style="list-style-type: none"> To identify a Cell in global (Globally Unique) EPC can know UE location based of ECGI 	ECGI (not more than 52 bits) = PLMN ID + ECI	P
ECI	E-UTRAN Cell Identifier	<ul style="list-style-type: none"> To identify a Cell within a PLMN 	ECI (28 Bits) = eNB ID + Cell ID	P
Global eNB ID	Global eNodeB Identifier	<ul style="list-style-type: none"> To identify an eNB in global (Globally Unique) 	Global eNB ID (not more than 44 bits) = PLMN ID + eNB ID	P
eNB ID	eNodeB Identifier	<ul style="list-style-type: none"> To identify an eNB within a PLMN 	20 bits	P
P-GW ID	PDN GW Identity	<ul style="list-style-type: none"> To identify a specific PDN GW (P-GW) HSS assigns P-GW for PDN (IP network) connection of each UE 	IP address (4 bytes) or FQDN (variable length)	P
TAI	Tracking Area Identity	<ul style="list-style-type: none"> To identify Tracking Area Globally unique 	TAI (not more than 32 bits) = PLMN ID + TAC	P
TAC	Tracking Area Code	<ul style="list-style-type: none"> To indicate eNB to which Tracking Area the eNB belongs (per Cell) Unique within a PLMN 	16 bits	P
TAI List	Tracking Area Identity List	<ul style="list-style-type: none"> UE can move into the cells included in TAL list without location update (TA update) Globally unique 	{TAI} (variable length)	P

PDN ID	Packet Data Network Identity	<ul style="list-style-type: none"> To identify an PDN (IP network), that mobile data user wants to communicate with PDN Identity (APN) is used to determine the P-GW and point of interconnection with a PDN With APN as query parameter to the DNS procedures, the MME will receive a list of candidate P-GWs, and then a P-GW is selected by MME with policy 	PDN Identify = APN = APN.NI + APN.OI (variable length)	P
EPS Bearer ID	Evolved Packet System Bearer Identifier	<ul style="list-style-type: none"> To identify an EPS bearer (Default or Dedicated) per an UE 	4 bits	T
E-RAB ID	E-UTRAN Radio Access Bearer Identifier	<ul style="list-style-type: none"> To identify an E-RAB per an UE 	4 bits	T
DRB ID	Data Radio Bearer Identifier	<ul style="list-style-type: none"> To identify a DRB per an UE 	4 bits	T
LBI	Linked EPS Bearer ID	<ul style="list-style-type: none"> To identify the default bearer associated with a dedicated EPS bearer 	4 bits	T
TEID	Tunnel End Point identifier	<ul style="list-style-type: none"> To identify the end point of a GTP tunnel when the tunnel is established 	32 bits	T

P: Permanent T: Temporary

Table 6. Description of LTE identifiers (from [18])

1. Cell Radio Network Temporary Identifier

The cell radio network temporary identifier (C-RNTI) is assigned by the serving eNB to a UE during the RRC attach procedure. The C-RNTI is an E-UTRAN specific identifier and the EPC network has no context information about it. The C-RNTI is transmitted in clear text [6] since there are no security protocols during the initial attach procedure.

There are various versions of the C-RNTI [19] used by the E-UTRAN in a cell:

- C-RNTI: unique identification used for identifying RRC Connection and scheduling
- Semi-persistent scheduling C-RNTI: unique identification used for semi-persistent scheduling;
- Temporary C-RNTI: identification used for the random access procedure
- TPC-PUSCH-RNTI: identification used for the power control of PUSCH
- TPC-PUCCH-RNTI: identification used for the power control of PUCCH

The UE may be configured by RRC with a DRX functionality that controls the UE's PDCCH monitoring activity for the UE's C-RNTI or TPC-PUCCH-RNTI or TPC-PUSCH-RNTI or semi-persistent scheduling C-RNTI [16].

A UE uses the same C-RNTI on all serving cells [16] in the E-UTRAN. RNTI values used in the MAC layer are shown in Table 7.

Value (hexa-decimal)	RNTI
0000	N/A
0001-003C	RA-RNTI, C-RNTI, Semi-Persistent Scheduling C-RNTI, Temporary C-RNTI, TPC-PUCCH-RNTI and TPC-PUSCH-RNTI (see note)
003D-FFF3	C-RNTI, Semi-Persistent Scheduling C-RNTI, Temporary C-RNTI, TPC-PUCCH-RNTI and TPC-PUSCH-RNTI
FFF4-FFFC	Reserved for future use
FFFD	M-RNTI
FFFE	P-RNTI
FFFF	SI-RNTI

Table 7. RNTI values (from [16])

The usage of the RNTI values by the MAC layer in the associated transport and logical channels are shown in Table 8.

RNTI	Usage	Transport Channel	Logical Channel
P-RNTI	Paging and System Information change notification	PCH	PCCH
SI-RNTI	Broadcast of System Information	DL-SCH	BCCH
M-RNTI	MCCH Information change notification	N/A	N/A
RA-RNTI	Random Access Response	DL-SCH	N/A
Temporary C-RNTI	Contention Resolution (when no valid C-RNTI is available)	DL-SCH	CCCH
Temporary C-RNTI	Msg3 transmission	UL-SCH	CCCH, DCCH, DTCH
C-RNTI	Dynamically scheduled unicast transmission	UL-SCH	DCCH, DTCH
C-RNTI	Dynamically scheduled unicast transmission	DL-SCH	CCCH, DCCH, DTCH
C-RNTI	Triggering of PDCCH ordered random access	N/A	N/A
Semi-Persistent Scheduling C-RNTI	Semi-Persistently scheduled unicast transmission (activation, reactivation and retransmission)	DL-SCH, UL-SCH	DCCH, DTCH
Semi-Persistent Scheduling C-RNTI	Semi-Persistently scheduled unicast transmission (deactivation)	N/A	N/A
TPC-PUCCH-RNTI	Physical layer Uplink power control	N/A	N/A
TPC-PUSCH-RNTI	Physical layer Uplink power control	N/A	N/A

Table 8. RNTI usage (from [16])

C. CONNECTING TO A LONG TERM EVOLUTION NETWORK

When a UE initially powers on, it uses an initial synchronization process to search for the correct frequency from the many different ones available on the air. Timing is critical because a UE can be moving from the base station, and LTE requires microsecond level precision. The speed-of-light propagation delay can cause a collision or a timing problem [4]. Once synchronized to the correct frequency, the UE reads the system information to find the allowable public land mobile network (PLMN) to connect to [20]. If the PLMN value is correct, it reads more system information on network resources. When a subscribed user is in her operator's PLMN, it is called a home-PLMN. Roaming allows users to move outside their home network and use the resources from another operator's network, called a visited-PLMN.

In order to gain access to the network's resources or channels, the UE initiates a random access procedure over a shared channel with the eNB using the RRC protocol. If there are many UEs in the cell, a contention based random access procedure is used to prevent collisions between the many requests. Alternatively, a contention free or non-contention based random access procedure can be used whereby an eNB assigns a 6 bit preamble code to the UE to prevent its request from colliding with other UE requests.

1. System Information Acquisition

When a UE first powers on, it attempts to acquire physical cell identification (PCI), time slot and frame synchronization so it can read system information (SI) from a particular network using a system information acquisition procedure. The UE detects the PCI from the primary synchronization signal (PSS) and secondary synchronization signal (SSS) regularly broadcast by the eNB. System information is divided into a master information block (MIB) and a number of system information blocks (SIBs). The contents of the MIB and SIBs are specified in [21].

The MIB defines the most essential physical layer information of the cell required to receive further system information [19]. SystemInformationBlockType1 (SIB1) contains information relevant when evaluating if a UE is allowed to access a cell and

defines the scheduling of other system information blocks. SystemInformationBlockType2 (SIB2) contains radio resource configuration, common and shared channel information which is common for all UEs. A 28-bit E-UTRAN cell identifier which identifies a radio cell within a PLMN is broadcast with SIB1 [22]. The MIB is mapped on the logical BCCH and carried on transport and physical BCH while all other SI messages are mapped on the BCCH and dynamically carried on DL-SCH where they can be identified through the System Information RNTI (SI-RNTI). Both the MIB and SIB1 use a fixed schedule with a periodicity of 40 and 80 milliseconds, respectively, while the scheduling of other SI messages is flexible and indicated by SIB1. The content of the MIB includes the downlink channel bandwidth in terms of resource blocks (RB), the PHICH configuration (duration and resource) and the system frame number (SFN) [19]. Some of the cell access parameters contained in SIB1 and SIB2 are shown in Table 9 and Table 10.

PLMN identity: Up to 6 PLMN identities can be specified
Tracking area code: Range from 0 to 65546
Cell Id: 28 bits eNB identity
Cell barred: whether cell is barred or not
Intra Frequency cell reselection info: To select other cells when the target cell is barred
CSG indication: To indicate whether this cell is a Closed Subscriber Group (CSG) cell or not. If it is CSG cell, then CSG identity stored in the UE should match with CSG id of the cell
q-RxLevMin: Minimum required level in the cell
Band indicator: Cell frequency band indicator
Scheduling information of other SIBs

Table 9. Some of the contents of SIB1 (after [23])

Access Class Barring Parameters
Random access channel (RACH) related parameters
Idle mode paging configurations which includes the defaultPagingCycle parameter for the default DRX cycle in idle mode in terms of radio frames
Uplink physical control channel (PUCCH) and shared channel (PUSCH) configurations
Uplink power control and sounding reference signal configurations
Uplink carrier frequency / bandwidth
Cell barring information

Table 10. Some of the contents of SIB2 (after [23])

If the network changes the system information, it first notifies the UEs about the change using a modification period, after which it transmits the updated system information. A paging message, with the systemInfoModification parameter, informs the UE that the system information will change at the next modification period boundary [21].

2. Bearers

The initial attach procedure is used to authenticate and authorize the UE to send and receive data, as well as obtain an IP address. A data path from the UE through the eNB to the MME, S-GW and P-GW is established at the end of the attach procedure. There are several kinds of data paths or bearers as shown in Figure 13. A packet data network (PDN) connection is composed of at least one default bearer, created during the attach procedure, and possibly additional dedicated bearers as shown in Figure 14. A default bearer is always a non-guaranteed bit rate type offering best effort service, such as bursty internet traffic. Services requiring specific QoS performance (i.e., voice, video streaming) use guaranteed bit rate bearers (GBRs) with resources permanently allocated by admission control or dedicated bearers with traffic flow templates (TFT). Each default bearer is linked to the other bearers because they share the same UE IP address and APN

identifier. A data radio bearer (DRB) transports the packets between a UE and an eNB. An E-UTRAN radio access bearer (E-RAB) transports the packets between the UE and the EPC. A data radio bearer (DRB) transports the packets between a UE and an eNB. An E-UTRAN radio access bearer (E-RAB) transports the packets between the UE and the EPC.

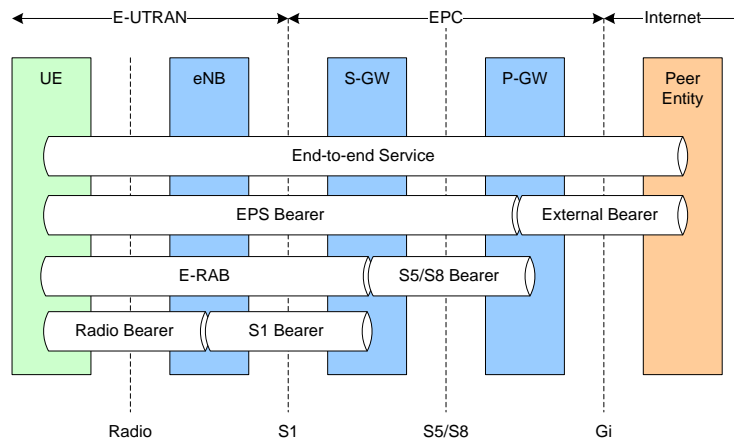

Figure 13. EPS bearer service architecture (from [19])

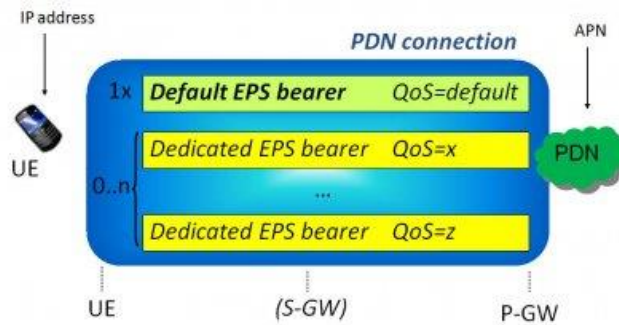

Figure 14. PDN connection and EPS bearer (from [24])

3. Radio Resource Control Protocol

The radio resource control (RRC) protocol, which exists in the UE and the eNB, is used to perform connection control and management, including establishment of the radio bearer. RRC provides broadcast of common control information from the upper layers and transfer of dedicated control information for a specific UE. The main services and functions of the RRC layer [19] include:

- Broadcast of system information related to the non-access stratum (NAS)
- Broadcast of system information related to the access stratum (AS)
- Paging
- Establishment, maintenance and release of an RRC connection between the UE and E-UTRAN including:
 - Allocation of temporary identifiers between UE and E-UTRAN
 - Configuration of low priority signaling radio bearers (SRB) and high priority SRB
- Configuration of the security parameters and security functions including key management
- Establishment, configuration, maintenance and release of point to point radio bearers
- Mobility functions including:
 - UE measurement reporting and control of the reporting for inter-cell and inter-RAT (radio access technologies) mobility
 - Handover
 - UE cell selection and reselection and control of cell selection and reselection
 - Context transfer at handover
- Notification and counting for MBMS services
- Establishment, configuration, maintenance and release of radio bearers for MBMS services
- QoS management functions
- UE measurement reporting and control of the reporting
- NAS direct message transfer to/from NAS from/to UE

The RRC functions depend upon whether the UE is in the idle or connected mode. A UE is in the RRC_CONNECTED state when an RRC connection has been established; otherwise it is in the RRC_IDLE state [21]. In RRC_IDLE, the UE camps on a cell after a cell selection or reselection process monitoring information on radio link quality and cell status [12]. In RRC_CONNECTED, the UE monitors control channels associated with the shared data channel. The characteristics of RRC states are shown in Table 11.

Mode	States And Transitions
RRC_IDLE	<ul style="list-style-type: none"> • Operator's PLMN selection • A UE specific DRX may be configured by NAS upper layer • UE monitors a paging channel to detect incoming calls, system information • Cell selection or re-selection mobility • The UE shall have been allocated an ID which uniquely identifies the UE in a tracking area • No RRC context stored in the eNB
RRC_CONNECTED	<ul style="list-style-type: none"> • UE has an E-UTRAN-RRC connection and context in E-UTRAN • E-UTRAN knows the cell which the UE belongs to • Network controlled mobility (handover and inter-RAT cell change) • UE performs neighbor cell measurements and reports it • At PDCP/RLC/MAC level: <ul style="list-style-type: none"> ○ UE can transmit and/or receive data to/from network ○ UE monitors control signaling channel for shared data channel to determine if data is for it ○ UE reports channel quality information and feedback information ○ DRX period can be configured by the eNB according to UE activity level for UE power saving and efficient resource utilization

Table 11. Characteristics of RRC protocol states (after [19])

4. Random Access Channel Procedure

When the UE wants to initially attach to a LTE network, it must request a RRC connection from the eNB using a random access channel (RACH) procedure in order to obtain dedicated resources for a radio bearer. All MAC transmissions on the uplink shared channel (UL-SCH) must be scheduled RACH procedures. The RACH is triggered by five events [19]:

1. Initial access from disconnected state (RRC_IDLE)
2. RRC connection re-establishment or radio failure
3. Handover requiring random access procedure
4. Downlink or uplink data arrival during RRC_CONNECTED after uplink PHY has lost synchronization (possibly due to power save operation) or for UE positioning
5. Uplink data arrival when no dedicated scheduling request (PUCCH) channels available

Contention-based RACH, when multiple UEs attempt simultaneous access, can be used in all five events. Non-contention-based RACH applies to handover and downlink data arrival only. Figure 15 shows the steps in a contention-based RACH procedure.

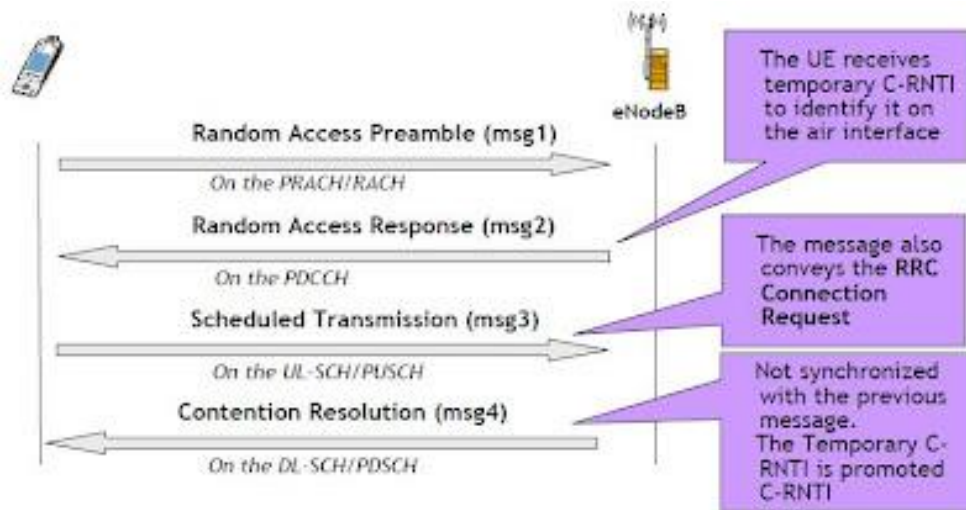

Figure 15. Contention-based RACH procedure (from [25])

In Figure 15 the UE sends msg1, which contains one randomly selected specific pattern or signature called a RACH preamble and a 6-bit random access radio network temporary identity (RA-RNTI), on the RACH in the uplink. The RA-RNTI is determined from the time slot number in which the preamble is sent [20] and the preamble is one out of a special set of 64 physical layer subcarriers using a Zadoff-Chu sequence. If another UE uses the same preamble at the same time, there will be contention for resources. If no response is received from the eNB, the UE will increase its power and send the RACH preamble again.

The eNB's random access response in msg2 is addressed to the RA-RNTI and sent by the MAC layer on the physical downlink control channel (PDCCH) using the downlink shared channel (DL-SCH). It indicates that resources have been reserved for the UE. For initial access, the response includes a RA-preamble identifier, timing alignment information, initial uplink grant, and assignment of a 16-bit temporary cell radio network temporary identifier (C-RNTI) to the UE.

The UE sends a scheduled transmission response in msg3 with the temporary C-RNTI requesting RRC connection, using hybrid automatic repeat-request (HARQ) and radio link control (RLC) transparent mode on the UL-SCH. In case the assigned temporary C-RNTI is in use by another UE, the message also contains either the temporary mobile subscriber identity (TMSI), if the UE has previously connected to the same network, or a random value, if the UE is connecting for the very first time. The TMSI is randomly assigned by the network to every registered UE.

The eNB sends msg4 with a new C-RNTI which will be used for further communication so that only the UE with it continues with the transmission while others back-off and try again after expiration of RACH specific timers. The C-RNTI is used in calculating the cyclic redundancy check (CRC) of PDCCH transmissions in the DL-SCH and for scrambling in the UL-SCH [14]. If no CRC error is detected, the PDCCH is for the UE. At the end of a successful RACH procedure, the UE is in RRC_CONNECTED state enabling it to exchange data with the eNB using dedicated signaling radio bearer 1 (SRB1). The UE can now read the PDCCH and PDSCH. During each DL-SCH, the UE checks the CRC with its C-RNTI. If the CRC is decoded successfully with its C-RNTI, the message is for the UE and it can find the DCI format from the payload size in that PDCCH.

5. Evolved Packet System Connection Management

There are two sets of states defined for the UE based on the information held by the MME as described in [10] and summarized here. The EPS mobility management (EMM) states of EMM-DEREGISTERED and EMM-REGISTERED are used to keep track of the current location of a UE. The EPS connection management (ECM) states of

ECM-IDLE and ECM-CONNECTED describe the signaling connectivity between the UE and the EPC. In general, the ECM and EMM states are independent of each other.

The UE enters the ECM-IDLE state when its signaling connection to the MME has been released or broken. In the ECM-IDLE state, there is no NAS signaling connection between the UE and the MME, and there is no context for the UE held in the eNB. As a result, the UE and the network can become unsynchronized with different EPS bearers. The ECM-CONNECTED state occurs when a UE is in RRC_CONNECTED state with the eNB, has a S1 connection with the MME and the EPS bearers are synchronized. In the ECM-CONNECTED state, the UE location is known to the MME with an accuracy of a serving eNB identity.

The UE and MME enter the EMM-REGISTERED state by a successful registration using the attach procedure with the eNB. After performing the detach procedure, the state is changed to EMM-DEREGISTERED in the UE and in the MME. In the EMM DEREGISTERED state, the EMM context in MME holds no valid location or routing information for the UE. The UE is not reachable by a MME, as the UE location is not known. In the EMM-DEREGISTERED state, some UE context can still be stored in the UE and MME to avoid running an authentication and key agreement (AKA) procedure during every attach procedure between the UE and MME.

The ECM and EMM states and transitions can be seen in Figure 16. In the EMM-REGISTERED and ECM-IDLE state, the UE performs a periodic tracking area updating procedure to maintain registration and enable the MME to page the UE, such as during the discontinuous reception (DRX) period.

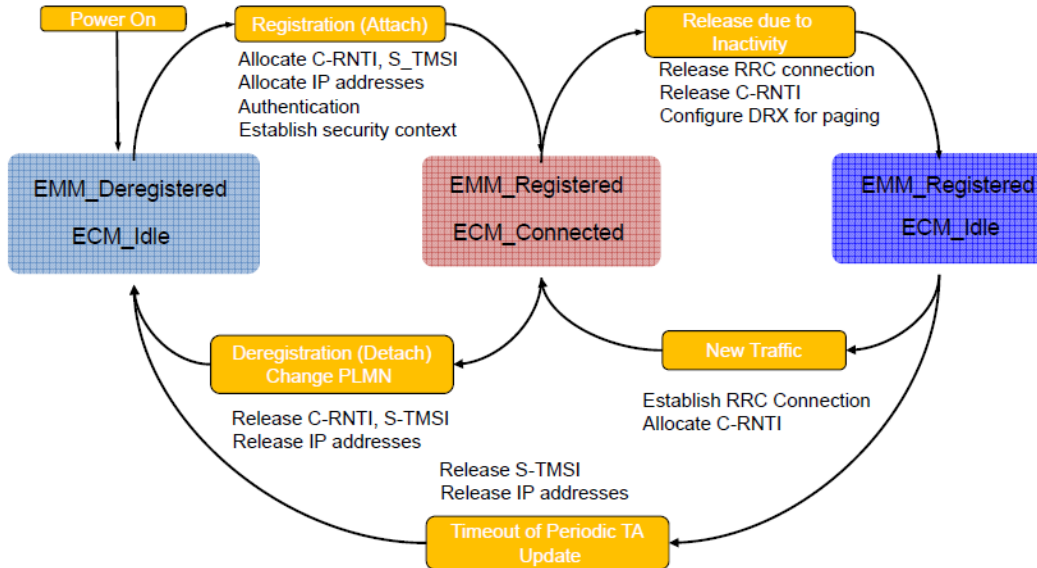

Figure 16. EMM and ECM state transitions (from [26])

D. LONG TERM EVOLUTION SECURITY

1. Security Architecture

A diagram of the 3GPP security architecture for LTE is shown in Figure 17. Both [6] and [27] present a comprehensive survey of security architecture, vulnerabilities and solutions in LTE and LTE-A networks. The network access security features (I) provide users with secure access to services, and protect against attacks on the radio access link [7]. The network domain security features (II), such as Internet Protocol security (IPsec), enable nodes to securely exchange signaling data, user data (between AN and SN, and within AN), and protect against attacks on the wireline network. The user domain security features (III) secure access to mobile stations. The application domain security features (IV) enable applications in the user and in the provider domain to securely exchange messages. The visibility and configurability of security features (V) enables the user to inform him whether a security feature is in operation or not and whether the use and provision of services should depend on the security feature. The defined security termination points in an EPS network are shown in Table 12. RRC integrity and confidentiality protection are provided by the PDCP layer between UE and eNB after the attach procedure and no layers below PDCP are protected [27]. Due to higher error rates

and longer round trip times in wireless networks, robust header compression (ROHC) is used to reduce the amount of header information that would travel over the air. As a result, security occurs below the ROHC since ROHC can only operate on unencrypted packets [4]. Ciphering is used for both AS and NAS signaling messages, as well as for AS user plane data.

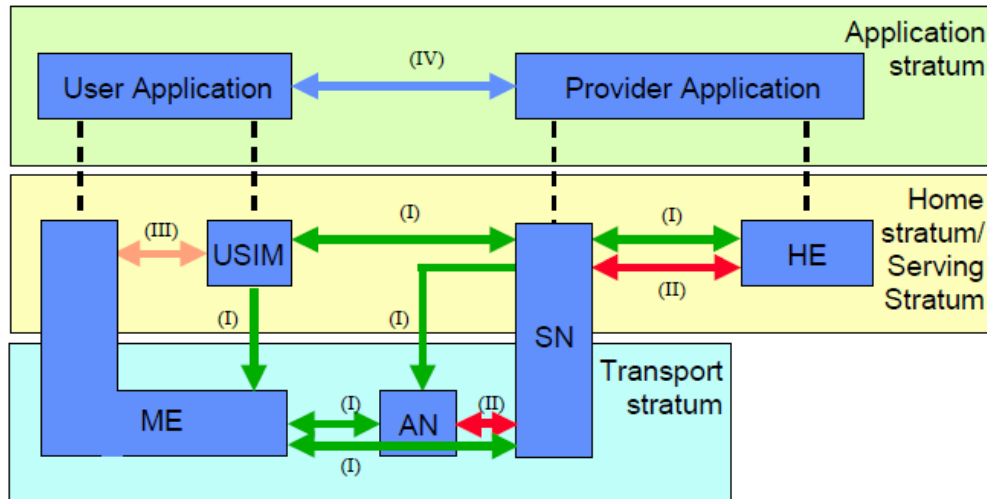

Figure 17. Overview of the security architecture (from [7])

	Ciphering	Integrity Protection
NAS Signalling	Required and terminated in MME	Required and terminated in MME
U-Plane Data	Required and terminated in eNB	Not Required (NOTE 1)
RRC Signalling (AS)	Required and terminated in eNB	Required and terminated in eNB
MAC Signalling (AS)	Not required	Not required
NOTE 1: Integrity protection for U-Plane is not required and thus it is not supported between UE and Serving Gateway or for the transport of user plane data between eNB and Serving Gateway on S1 interface.		

Table 12. Security termination points (from [19])

The LTE system utilizes an authentication and key agreement (AKA) procedure to achieve mutual authentication between the UE and the MME, as well as generate the ciphering key and integrity key used to derive different session keys for the encryption and the integrity protection [28]. Different AKA procedures are used when the UE accesses the EPC through distinct non-3GPP access networks.

2. Access Stratum Security

The lifetime of an access stratum (AS) security context is tied to the RRC connection because eNB keys are generated when the UE moves to connected mode and deleted when the UE goes to idle mode [19], [27]. Temporary identities are used to avoid the compromise of permanent identities between entities and reduce the time period during which an attacker could use them. AS security involves integrity protection and ciphering of RRC signaling carried by SRBs, and ciphering of user data carried by DRBs [21]. The RACH procedure results in a RRC_CONNECTED state and establishment of the dedicated SRB1. SRB1 is then used to transfer the initial NAS message from the UE to the MME, which results in the eNB receiving the UE context information from the EPC and establishing the S1 connection.

Upon receiving the UE context from the EPC, the eNB activates security using the AS security mode command procedure. The RRC command and successful response messages to activate security are integrity protected, while ciphering starts only after completion of the security mode command procedure. The use of cryptographic protection on S1-MME and X2-C is an operator's decision [7]. Once security is activated, all RRC messages receive integrity protection and ciphering by the PDCP layer. The eNB does not establish SRB2 and user DRBs prior to activating security and the UE only accepts a handover message when security has been activated. The integrity protection algorithm is common for SRB1 and SRB2. The ciphering algorithm is common for all radio bearers (i.e., SRB1, SRB2 and DRBs). SRB0 is not integrity protected or ciphered [7]. S1 interface signaling protection is optional [27]. The three defined SRBs (SRB0, SRB1 and SRB2) are used only for the transmission of RRC and NAS messages.

AS level security mode command procedure configures AS security (RRC and user plane) and NAS level security mode command procedure configures NAS security. The eNB keys are cryptographically separated from the EPC keys used for NAS protection to make it impossible to use the eNB key to figure out an EPC key [19]. Once NAS integrity has been activated, NAS messages without integrity protection are not accepted by the UE or MME [7]. The NAS service request is always integrity protected and the NAS attach request message is integrity protected if the EPS security context is not deleted while the UE is in EMM-DEREGISTERED state. The NAS security context has a longer lifetime than the AS security context and can also stay alive when the UE goes to idle until the EPS security context is deleted in either the UE or MME [27].

The AS and NAS security contexts are established during initial attach as shown in Figure 18.

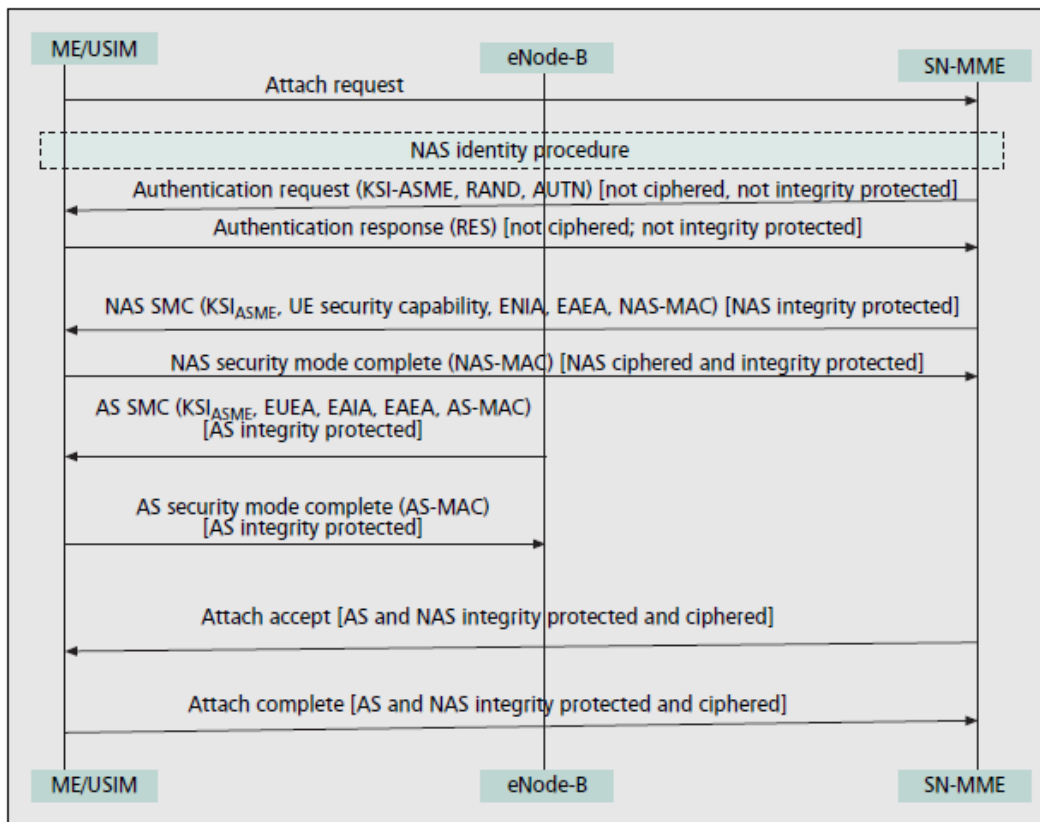

Figure 18. Establishment of NAS and AS security contexts during initial attach (from [27])

E. LONG TERM EVOLUTION DISCONTINUOUS RECEPTION PROTOCOL

The LTE power saving protocols, discontinuous reception (DRX) and discontinuous transmission (DTX), are both configured by the radio resource control (RRC) protocol. DRX mode can be enabled in either the RRC_IDLE or the RRC_CONNECTED states in 4G LTE as shown in Figure 19. 2G and 3G networks use DRX in idle mode only. In Figure 19, LTE-U_u is the new DRX air link interface between the eNB and the UE; S1_c is the DRX control plane reference point between the MME and the eNB; and S1_u is the DRX user plane reference point between the eNB and SGW.

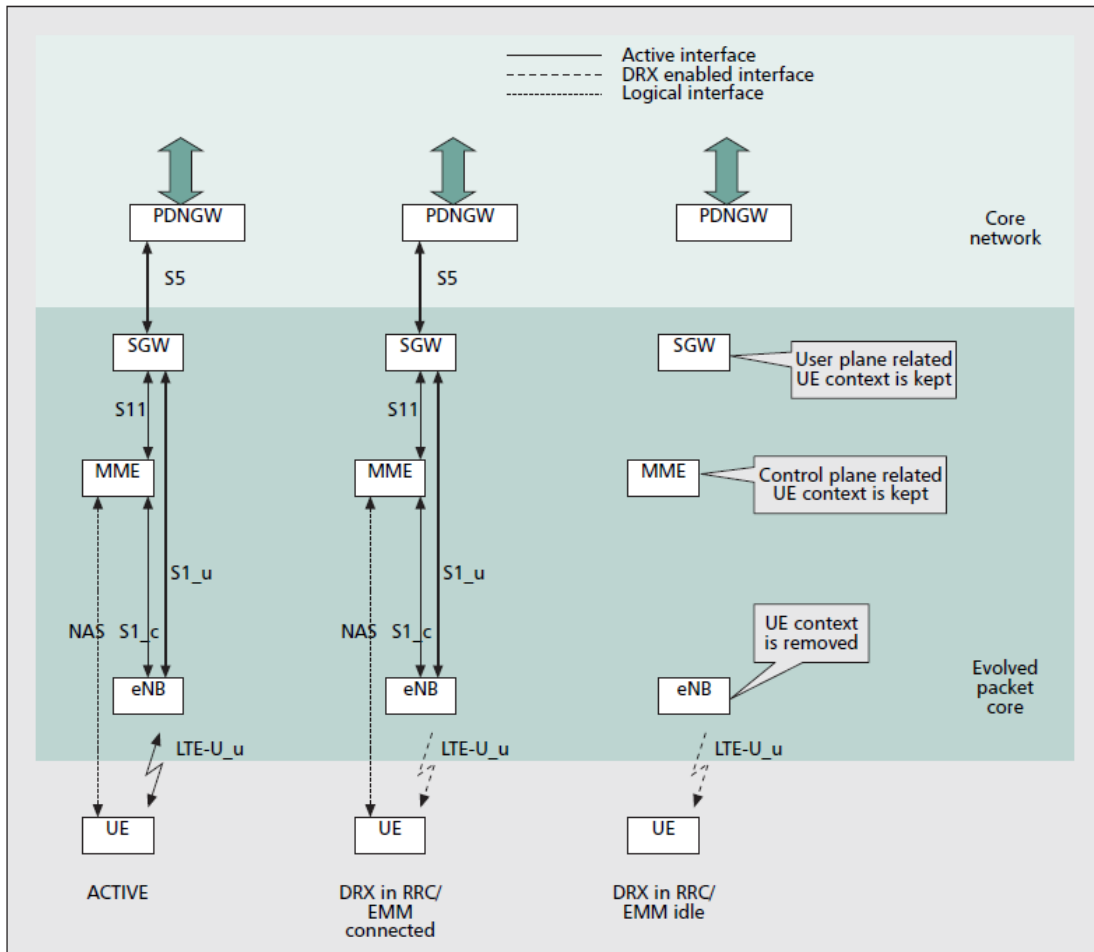

Figure 19. EPS DRX connection modes and states (from [29])

The eNB advertises the default DRX paging cycle in SystemInformationBlockType2 (SIB2) during the network attach procedure. The UE can use the DRX page cycle broadcast in SIB2 or propose a DRX cycle length using the InDeviceCoexIndication message [21]. In DRX mode, the UE powers down most of its circuitry when there are no packets to be transmitted or received [29]. The UE's transceiver is turned on periodically to transmit or receive packets. During DRX, the UE can still make periodic neighboring cell signal quality measurements and tracking area updates that it sends in periodic uplink packets to the eNB. Whether the UE keeps in sync with uplink transmission or not depends on whether the UE is registered with an eNB (RRC_CONNECTED state) or not (RRC_IDLE state). The transition between the short DRX cycle, the long DRX cycle and continuous reception is controlled either by a timer or by explicit commands from the eNB [30].

1. Short and Long Discontinuous Reception Cycles

The DRX cycle generally consists of a periodic repetition of an active time or “on duration” when the UE monitors the PDCCH, and an inactive time or “sleep mode” when it does not monitor downlink channels, as shown in Figure 20.

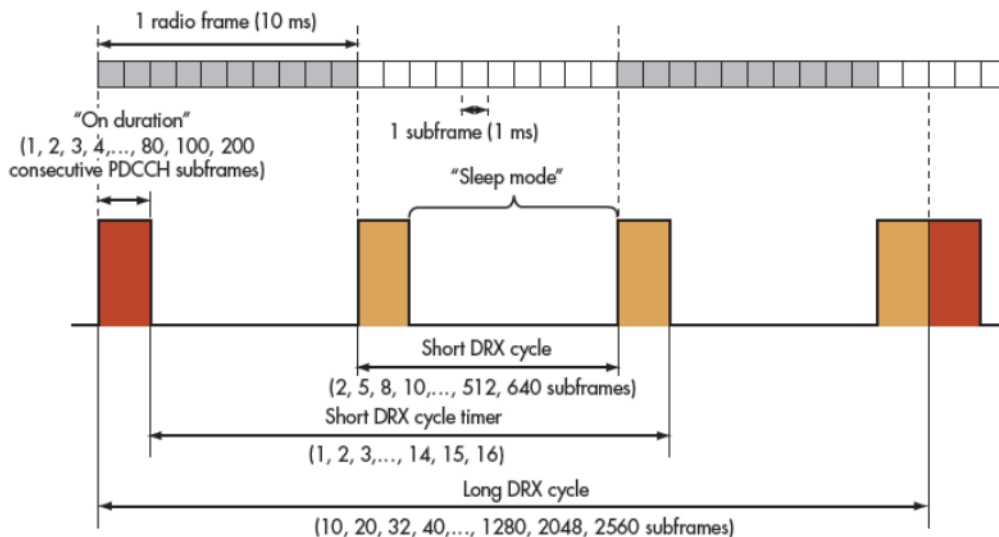

Figure 20. DRX cycles and timing (from [22])

A short DRX cycle has a shorter inactive time and is generally used for bursts of traffic where packets arrive more often with inactivity in between, such as in web browsing. The UE monitors the physical downlink control channel (PDCCH) more frequently during the short DRX cycle. The long DRX cycle has a longer inactive time and is most often used when packets arrive at a lower rate or during periods of low activity, such as during the RRC_IDLE state. The UE is usually configured to use a short DRX cycle for a predefined time before enabling a constant long DRX cycle to reduce the UE wake up time in case unexpected data arrives immediately after the DRX cycle is enabled [29]. Durations for long and short DRX are configured by the RRC and the transition is determined by eNB MAC control commands or by the UE based on an activity timer [4].

2. Connected State

The DRX mode can be enabled in RRC_CONNECTED state by either the eNB or UE when there are no outstanding or new packets to be transmitted or received [29]. In this state, the S1, NAS, and RRC connections are active and the rest of the network is unaware of the DRX data exchange on the air interface.

When the UE periodically wakes up, it checks to determine if pages have been transmitted by the eNB on the PDCCH with a radio network temporary identifier (C-RNTI or TPC-PUCCH-RNTI or TPC-PUSCH-RNTI or semi-persistent scheduling C-RNTI) assigned by the network during the attach procedure. The UE will return to active mode whenever a packet arrives from the eNB for it or whenever the UE needs to transmit packets to the eNB.

3. Idle State

When the UE does not have packets to be received and/or transmitted for an extended period of time, the UE will transition from the short to the long DRX period. The eNB will initiate the release of UE's RRC connection and request the MME to release the UE's S1 connection [29]. Subsequently, the eNB will remove the UE's context from the database, but the MME and SGW will only remove the eNB specific

part of the UE context. In this RRC_IDLE state, the UE is registered with EPS mobility management (EMM) but does not have an active session, meaning the S1, NAS, and RRC connections are non-existent [29]. The UE controls mobility by using signal quality measurements and tracking area updates of neighboring cells.

During this long DRX period, the UE wakes up periodically to listen to downlink transmissions and can initiate uplink traffic by requesting a RRC connection with the serving eNB. If the S-GW detects data addressed to the UE, the MME will ask all eNBs in the tracking area where the UE was last seen to transmit a page to the UE. If a UE finds its temporary mobile subscriber identity (STMSI) in the page message, it will initiate the random access procedure by sending the random access channel (RACH) preamble to the eNB. In RRC_CONNECTED state, the UE will send a transparent payload containing the NAS service request to the eNB, which will be forwarded to the MME, and the UE will return to EMM_ACTIVE mode. The eNB will then enable over-the-air encryption by sending the security mode command to the MME and establish the default data bearer.

4. User Equipment Feature Group Indicators

During the attach procedure, the UE signals its support for DRX which is forwarded to the MME [10]. Each bit of the feature group indicators (FGI) indicates the UE's support of a specific feature and is submitted to the network during the initial registration and attach procedure as part of the UE capability transfer [22]. Bits 4 and 5 define the support of the DRX cycle as shown in Figure 21.

4	Support of - Short DRX cycle	- can only be set to 1 if the UE has set bit number 5 to 1.	36.331, Annex B.1	Rel-8	pc_FeatGrp_4	Corresponding to the Index of Indicator, the leftmost binary bit 4 Set to true if supporting all functionalities in the feature group
5	Support of - Long DRX cycle - DRX command MAC control element		36.331, Annex B.1	Rel-8	pc_FeatGrp_5	Corresponding to the Index of Indicator, the leftmost binary bit 5 Set to true if supporting all functionalities in the feature group

Figure 21. Bits 4 and 5 of UE feature group indicators (from [31])

5. Medium Access Control Protocol Layer

The transition between the long and short DRX cycles is determined by the medium access control (MAC) layer control commands in the eNB or by the UE based on information exchanged during the attach procedure. The MAC handles the broadcast channel (BCH), downlink shared channel (DL-SCH), paging channel (PCH), uplink shared channel (UL-SCH) and the random access channel (RACH) [16].

A MAC protocol data unit (PDU) consists of a variable size MAC header, zero or more MAC random access responses (RAR) or payloads and optional padding as shown in Figure 22.

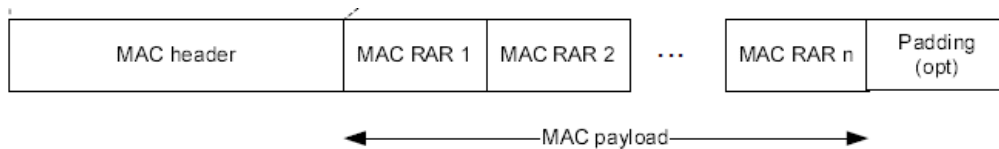

Figure 22. MAC protocol data unit (from [16])

The MAC RAR contains the 16-bit temporary C-RNTI used by the UE during RACH procedure as shown in Figure 23.

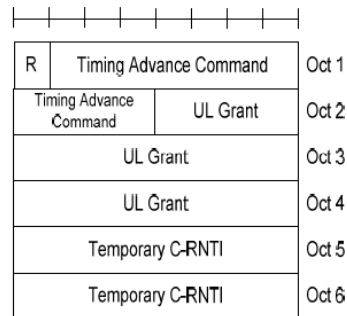

Figure 23. MAC Random access response (from [16])

The RRC MAC-MainConfig message, which is used to specify the MAC main configuration for signaling and data radio bearers, contains a DRX-Config section [27]. Table 13 describes some of the parameters and timers specified in DRX-Config.

DRX PARAMETER	DESCRIPTION
Active time	Time during which the UE is awake and monitors the PDCCH in PDCCH sub-frames
drx-InactivityTimer	The number of consecutive PDCCH sub-frame(s) to wait before enabling DRX after the sub-frame in which a PDCCH indicates an initial uplink or downlink user data transmission for this UE. Keeps UE awake for a certain period during data transfer even if the on-duration is expired
drx-RetransmissionTimer	The maximum number of consecutive PDCCH sub-frame(s) until a downlink retransmission is received
drxShortCycleTimer	The number of consecutive sub-frame(s) the UE shall follow the short DRX cycle
drxStartOffset	The sub-frame where the DRX cycle starts
onDurationTimer	The number of consecutive PDCCH sub-frame(s) the UE reads at the beginning of a DRX cycle. Defines the minimum average awake time of a UE.
longDRX-CycleStartOffset	If the short DRX cycle is configured, the value of the long DRX cycle is a multiple of the short DRX cycle in number of sub-frames.

Table 13. DRX parameters (after [16])

The MAC layer multiplexes data units from logical channels to transport channels. Logical channels are differentiated by a five bit logical channel identity (LCID) included in the MAC PDU header. The MAC PDU header consists of one or more MAC PDU sub-headers, and each sub-header corresponds to either a MAC SDU or a MAC control element or padding. A MAC PDU sub-header consists of the six header fields R/R/E/LCID/F/L, except for the last sub-header, which consists solely of the four header fields R/R/E/LCID as shown in Figure 24. A maximum of one MAC PDU can be transmitted per transport block per UE. Therefore, the UE has one MAC PDU in the uplink and the eNB will have multiple parallel MAC PDUs in the downlink direction since it handles multiple UEs.

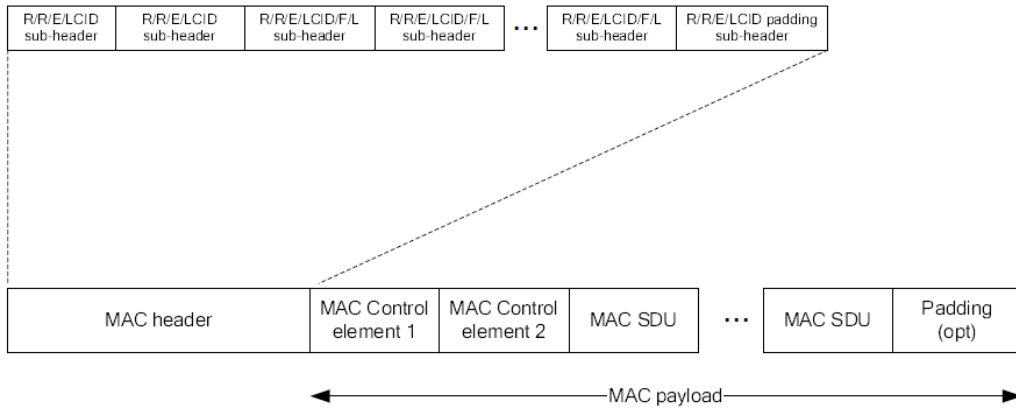

Figure 24. Example of MAC PDU (from [16])

There is one LCID field for each MAC SDU, MAC control element or padding included in the MAC PDU. The defined LCIDs are shown in Figure 25 and Figure 26.

Index	LCID values
00000	CCCH
00001-01010	Identity of the logical channel
01011-11010	Reserved
11011	Activation/Deactivation
11100	UE Contention Resolution Identity
11101	Timing Advance Command
11110	DRX Command
11111	Padding

Figure 25. Values of LCID for DL-SCH (from [16])

Index	LCID values
00000	CCCH
00001-01010	Identity of the logical channel
01011-11000	Reserved
11001	Extended Power Headroom Report
11010	Power Headroom Report
11011	C-RNTI
11100	Truncated BSR
11101	Short BSR
11110	Long BSR
11111	Padding

Figure 26. Values of LCID for UL-SCH (from [16])

F. RELATED WORK IN LONG TERM EVOLUTION SECURITY VULNERABILITIES DURING DISCONTINUOUS RECEPTION PERIOD

It has been suggested in a few LTE security research papers that the long discontinuous reception (DRX) period is one of several potential security vulnerabilities in LTE [5], [6]. However, no research has been conducted to show how such an exploit could actually be conducted during the long DRX period, nor why the LTE DRX protocol is vulnerable to cyber attacks given its robust security architecture. Part of the reason may be that the impact of these security vulnerabilities is dependent on the vendor implementation of DRX algorithms. Currently, most of the Qualcomm based LTE handsets do not fully implement the connected mode DRX feature [20].

In [5], Fosberg et al. state that the PHY data frame (transport block) is not encrypted in both the downlink and uplink directions, making it possible for any attacker with a receiver to detect and read the control (C-PDU) and data (D-PDU) protocol data units of the RLC/MAC/PDCP sub-layers inside them. They assume that a passive attacker can understand the PDUs and associate them with the C-RNTIs. Their assumption that there is no confidentiality or integrity protection at MAC layer but there is integrity protection on the RRC layer is correct given the information in Table 12. The C-RNTI and related resource allocation and other PHY control information is transmitted in the downlink without security during the RACH procedure as explained in Section II.D.2. Since the same C-RNTI is used by the UE within a tracking area, it would provide UE presence information for an attacker and a possible way to correlate the C-RNTI with the user's service level identity. Fosberg et al. claim that a potential security hole exists during the DRX period in active mode when the UE keeps its context (e.g., C-RNTI) in the eNB and is still allowed to transmit packets [5]. They conclude that "an adversary can inject a C-PDU to the system by using the C-RNTI of a UE in long DRX period," but not a D-PDU which is protected by upper layer security mechanisms, "and the cost to launch this attack is lower than radio jamming attack." The possible denial of service (DoS) attack described is shown in Figure 27.

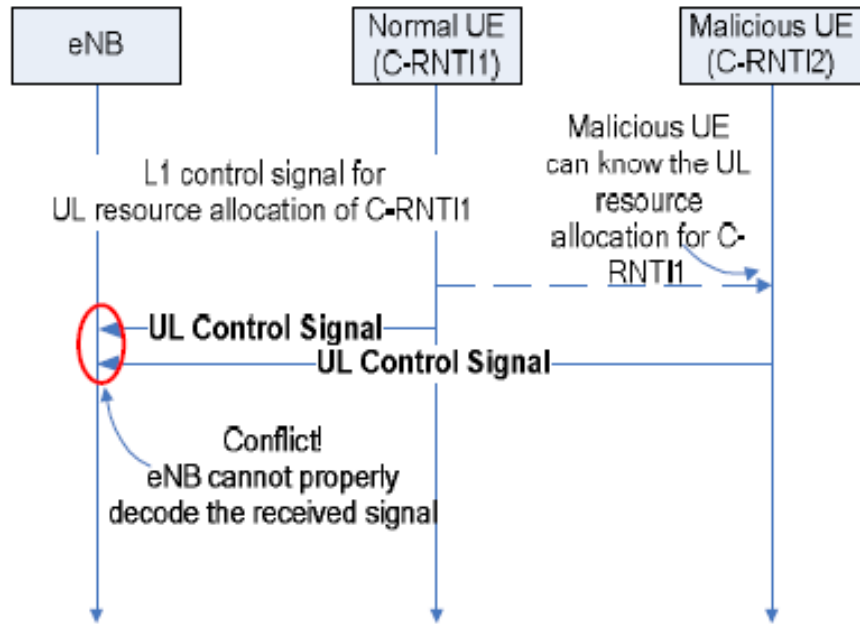

Figure 27. Denial of service attack using C-RNTI (from [5])

An attacker can also passively track a UE based on the packet sequence numbers. As Forsberg et al. state [5],

If the user plane (RLC, PDCP) or control plane (RRC, NAS) packet sequence numbers are continuous before and after a handover, a passive attacker can guess the mapping between the old and new C-RNTIs with a high probability based on the continuity of the packet sequence numbers.

An eNB uses buffer status reports sent by a UE in a C-PDU for packet scheduling, load balancing, and admission control. Foster et al. claim that during the long DRX period, an attacker could actively impersonate the UE by sending fake buffer status reports that report more data to send than are actually buffered. Since the UE does not send these reports during the long DRX period, the fake buffer status report will not conflict with real reports from an active UE as shown in Figure 28. As a result, if the eNB thinks there is congestion in the cell, it may not accept newly arriving UEs. Their proposed solution to these attacks is a periodic re-allocation of the C-RNTI to make it more difficult for an attacker to detect if new UEs are arriving or if existing ones are getting refreshed C-RNTIs. Another proposed solution is ciphering of RRC messages.

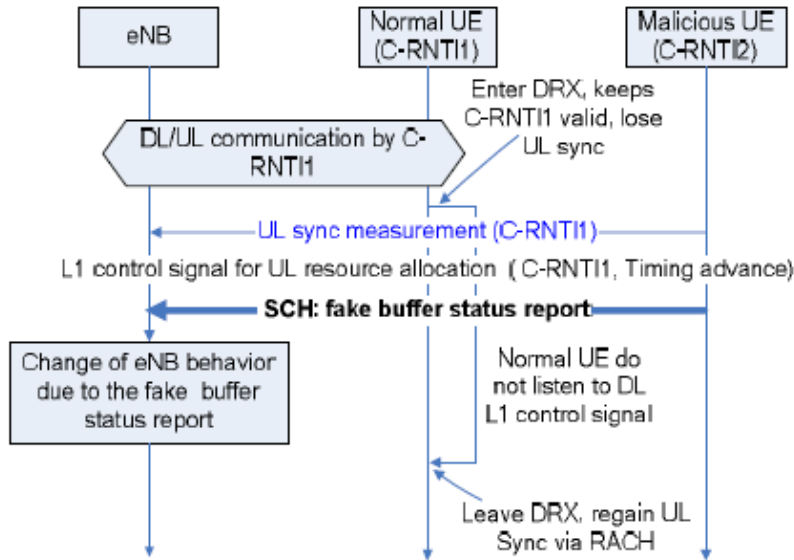

Figure 28. Successful packet injection attack (from [5])

Seddigh et al. [6] provide a good description of security in LTE and WiMax. Expanding upon the information in [5], Seddigh et al. suggest two other ways a DoS attack could be launched using the C-RNTI. The first way against a particular UE could be accomplished by an attacker intercepting the resource scheduling information and the C-RNTI to send an uplink control signal at the scheduled time creating a conflict at the eNB and service problems for the real UE. The second way is by injecting C-PDU packets during the DRX period to cause DoS attacks against newly arriving users.

III. METHODOLOGY

A review of the current Long Term Evolution (LTE) standards at the 3GPP website and current work in security vulnerabilities was conducted and is summarized in Section II. Detailed information on the radio resource control (RRC) and discontinuous reception (DRX) protocols was gathered and analyzed. In this section, a review of the open source ns-3 network LTE simulator is conducted to ascertain if it can be used to demonstrate security vulnerabilities in LTE. To verify the results of the simulator, it is also necessary to analyze captured LTE packet traces and use them as input to the simulator.

A. DESCRIPTION OF NS-3 OPEN SOURCE NETWORK SIMULATOR

ns-3 is a free discrete-event network simulator, licensed under the GNU GPLv2 license¹ and is publicly available for research, development, and educational use [32]. It is built as a system of open source software libraries primarily developed on GNU/Linux platforms that work together. ns-3 is distributed as source code, so the target system needs to have a software development environment to build the libraries first before building the user programs.

B. DESCRIPTION OF THE LENA MODULE IN NS-3

LENA is a free open source product-oriented LTE/EPC network simulator based on the ns-3 network simulator.² The most recent stable version of the LENA code (version 8) gets periodically merged with the most recent official stable version of ns-3 (ns-3.19) and is available from the ns-3 website. It is actively being used for research [33].

The following information was found in the manual for LENA [34]. The manual includes examples of writing simulation programs using ns-3, including configuration of various LTE and EPC model parameters. LENA supports the femto application platform

¹ More information can be found at <http://www.gnu.org/copyleft/gpl.html>

² More information can be found at <http://networks.ctc.es/mobile-networks/software-tools/lena/>

interface (FAPI) published by the FemtoForum³ for LTE femtocells. FAPI is a logical specification only, and its implementation is left to the vendors. The LENA simulator is designed to be independent from vendor-specific implementations of FAPI.

The LTE-EPC simulation model is shown in Figure 29. The LTE model includes the radio protocol stack (RRC, PDCP, RLC, MAC, PHY) within the UE and the eNB nodes. The EPC model includes the core network interfaces, protocols and entities within the SGW, PGW and MME nodes, and partially within the eNB nodes.

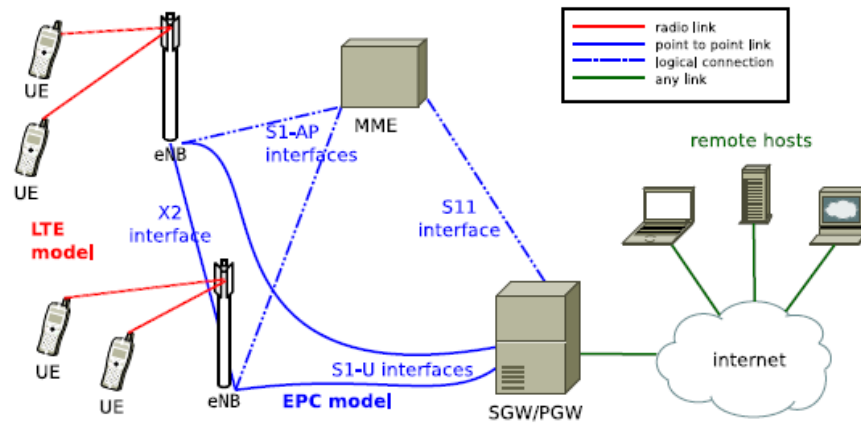

Figure 29. Overview of the LTE-EPC simulation model (from [34])

The LTE model supports evaluation of radio resource management, QoS-aware packet scheduling, inter-cell interference coordination and dynamic spectrum access. The architecture of the LTE radio protocol stack model of the UE in the data plane is shown in Figure 30 and for the control plane in Figure 31. The architecture of the PHY and channel model of the UE is shown in Figure 32.

The channel model uses the SpectrumChannel interface in the ns-3 spectrum module. The ns-3 Buildings module is used as a propagation model by indicating the position of the node (i.e., whether it is indoor or outdoor, and what is its z-axis with respect to the rooftop level). LENA considers frequency division duplexing (FDD) only

³More information can be found at <http://www.smallcellforum.org/resources-technical-papers>

and implements downlink and uplink propagation separately. A trace-based fading model is available, but it needs a lot of memory for storing the traces. The LTE PHY model supports antenna modeling using the ns-3 AntennaModel class with the IsotropicAntennaModel as the default.

The LTE model includes a random access procedure, as well as the PHY, MAC, RLC and PDCP protocol layers. It currently supports the output to file of PHY, MAC, RLC and PDCP level key performance indicators (KPIs).

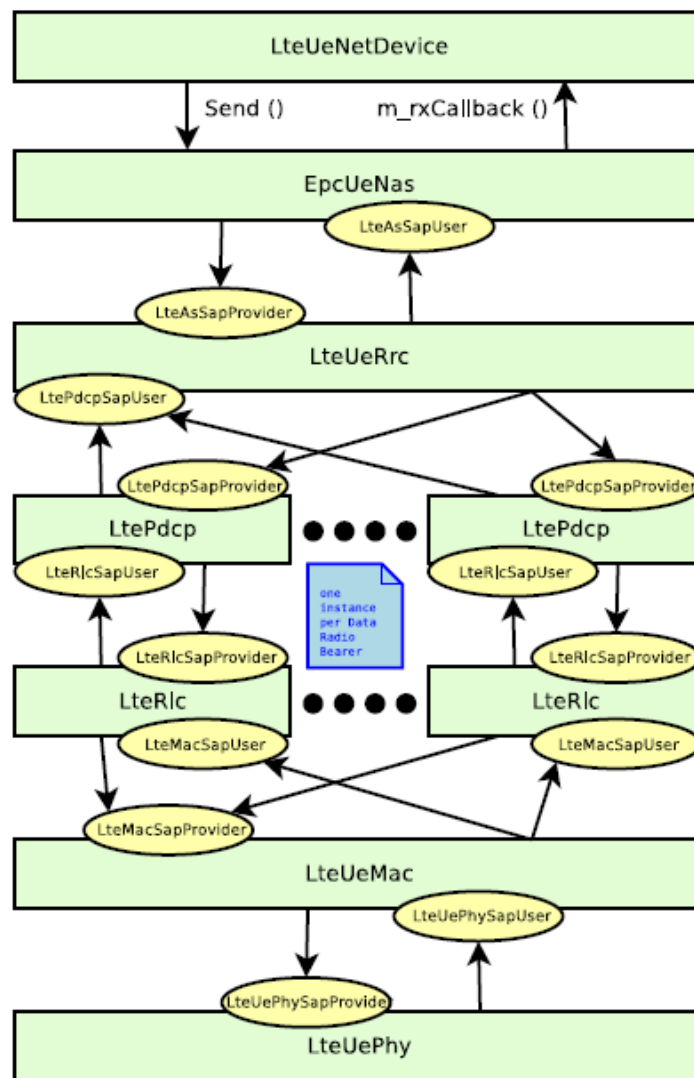

Figure 30. LTE radio protocol stack model for UE on the data plane (from [34])

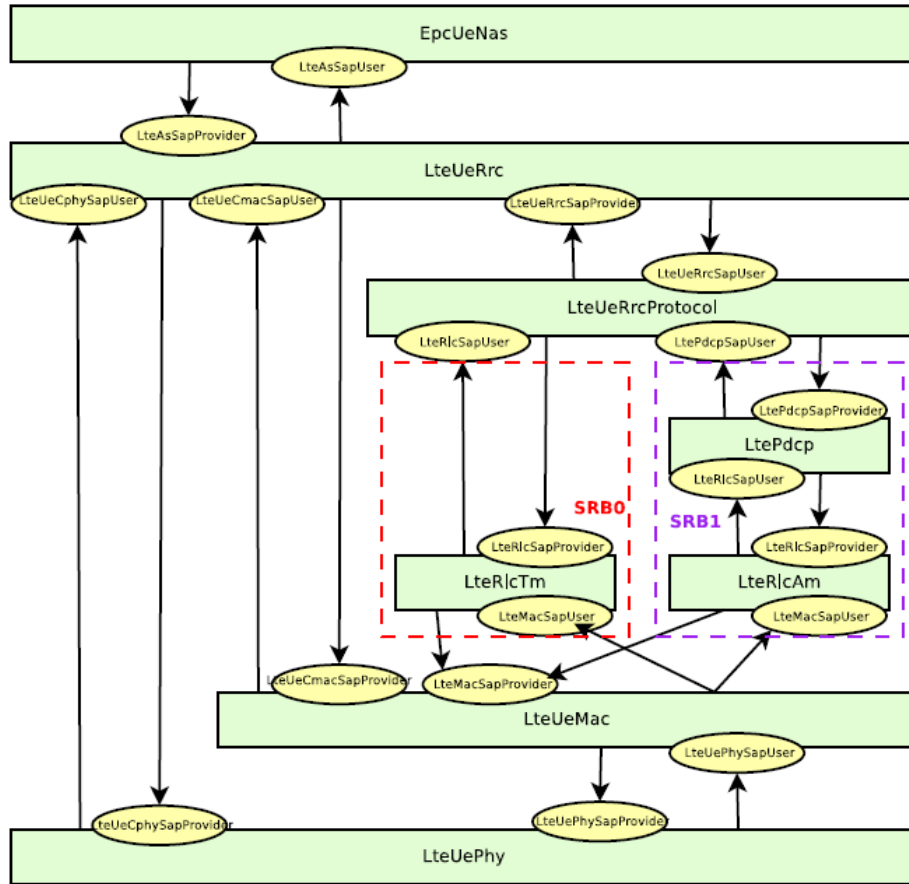

Figure 31. LTE radio protocol stack model for UE on the control plane (from [34])

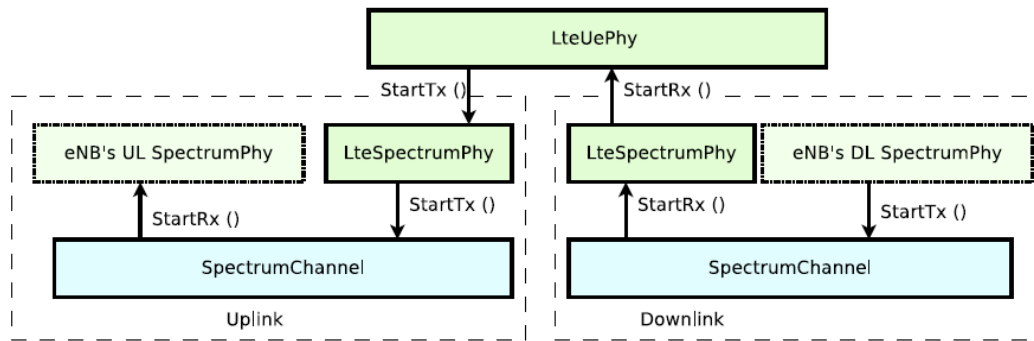

Figure 32. LTE PHY and channel model architecture for UE (from [34])

The architecture of the LTE radio protocol stack model of the eNB is shown in Figure 33 and for the control plane in Figure 34. The architecture of the PHY and channel model of the eNB is shown in Figure 35. The physical layer model includes the inter cell interference calculation and the simulation of uplink traffic, including both packet transmission and CQI generation.

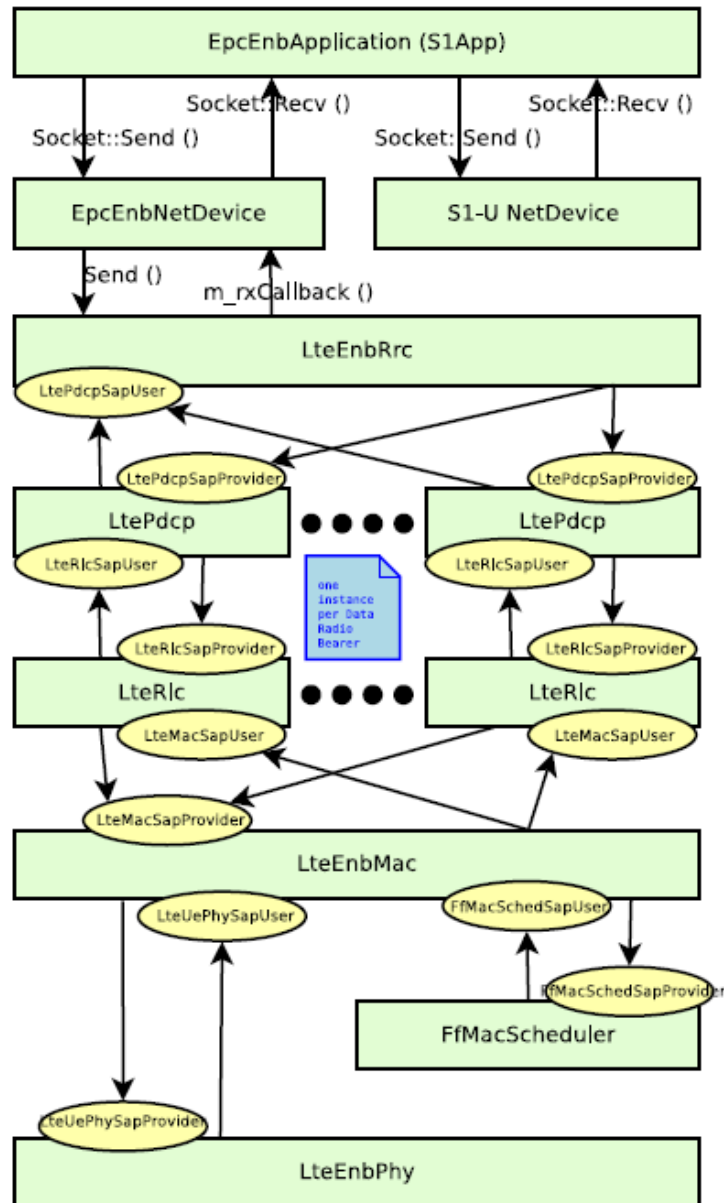

Figure 33. LTE radio protocol stack architecture for eNB on the data plane (from [34])

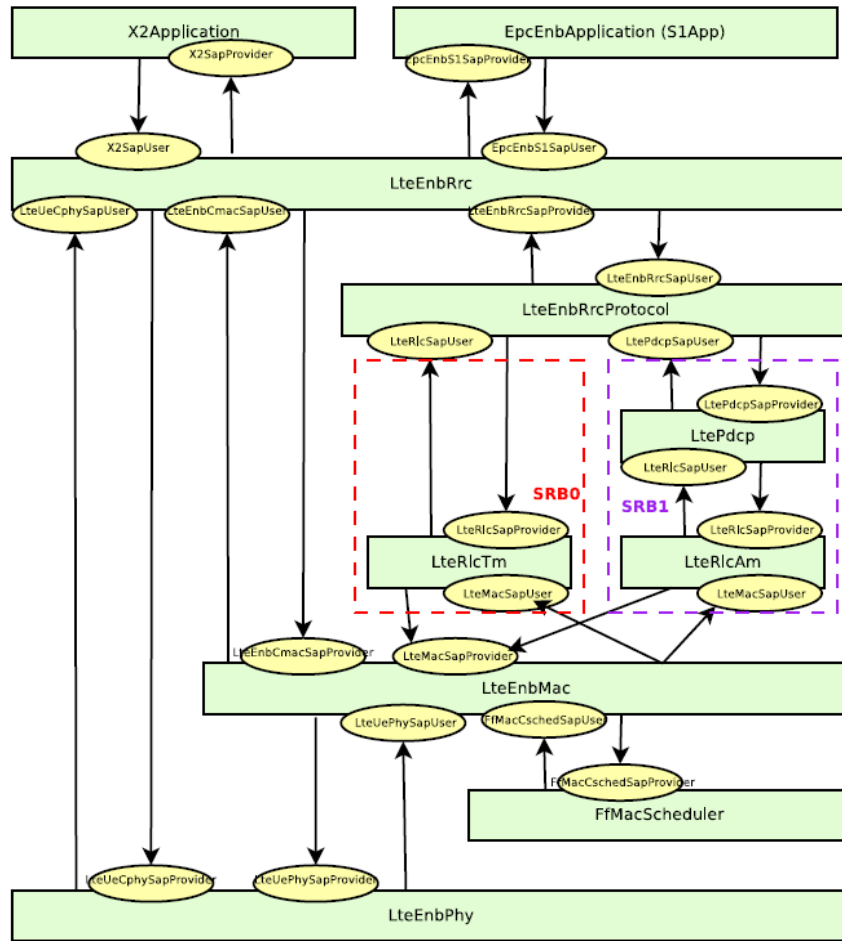

Figure 34. LTE radio protocol stack architecture for eNB on the control plane (from [34])

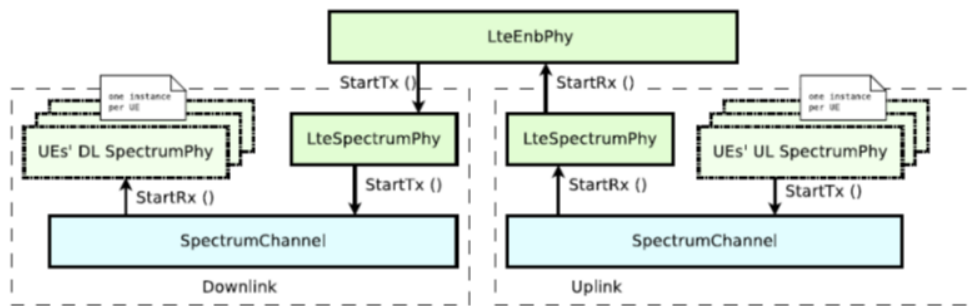

Figure 35. LTE PHY and channel model architecture for eNB (from [34])

In the EPC model, the SGW and PGW functional entities are implemented within a single node referred to as the SGW/PGW node. Simulation of end-to-end IP connectivity over the LTE model supporting interconnection of multiple UEs to the Internet, via a radio access network of multiple eNBs connected to the SGW/PGW node, is supported. Only IPv4 is supported. X2-based handover between two eNBs and multiple EPS bearers for each UE can be simulated. The end-to-end LTE-EPC data plane protocol stack, including the 3GPP S1-U protocol and the LTE radio protocol stack layers, in the simulator can be seen in Figure 36. The S5 or S8 interfaces are not modeled at all since a combined SGW and PGW node is used.

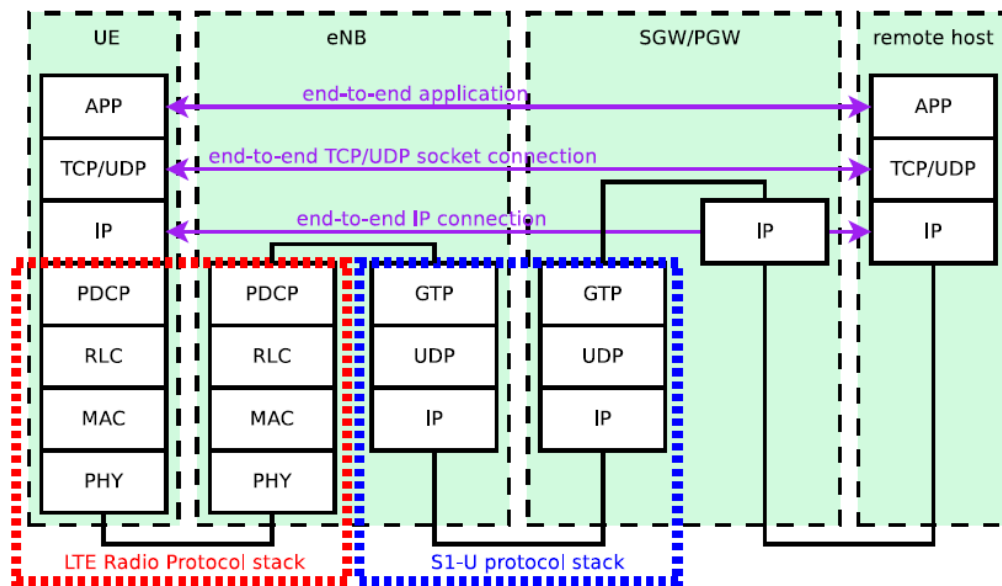

Figure 36. LTE-EPC data plane protocol stack in LENA model (from [34])

The architecture of the EPC control plane model is shown in Figure 37. The S1-AP and the S11 control interfaces are modeled simply as a direct function call between the two objects. The X2-AP control interface is modeled more accurately using protocol data units sent over an X2 link.

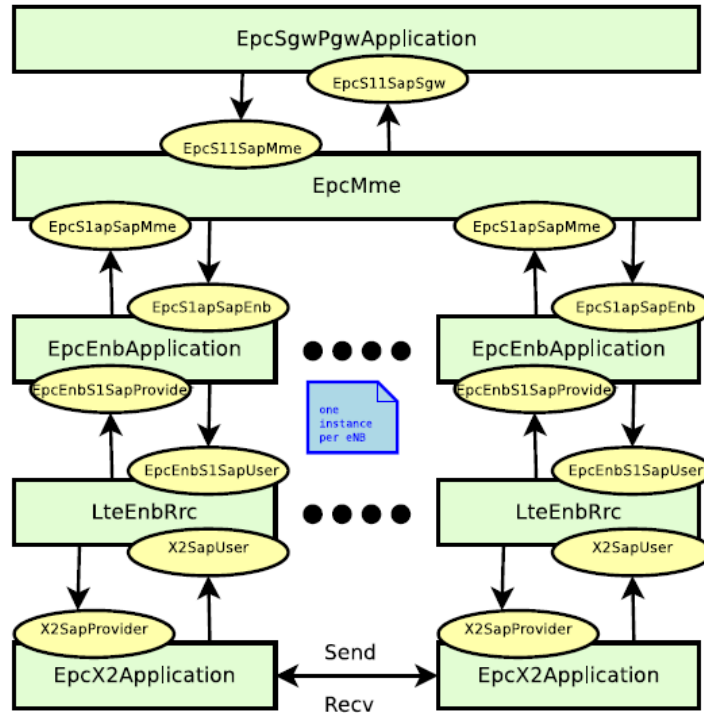

Figure 37. EPC control plane model (from [34])

The sub-frame structure in LENA is divided into a control and a data part as shown in Figure 38. The model assumes that the downlink control frame starts at the beginning of each sub-frame and lasts up to three symbols across the whole system bandwidth, where the actual duration is provided by the PCFICH. A PDCCH transports a single message DCI coming from the MAC layer, where the scheduler indicates the resource allocation for a specific user. The sounding reference signal (SRS) is periodically placed in the last symbol of the sub-frame in the whole system bandwidth. The RRC module includes an algorithm for dynamically assigning the SRS periodicity as function of the actual number of UEs attached to an eNB according to the UE-specific procedure specified in [17].

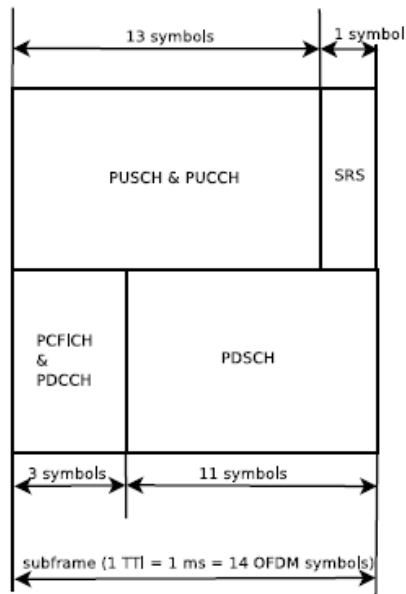

Figure 38. LTE sub-frame in LENA (from [34])

The RRC model implemented in the simulator provides the following functionality:

- generation at the eNB and interpretation at the UE of the MIB, SIB1 and SIB2
- initial cell selection
- RRC connection establishment procedure
- RRC reconfiguration procedure
- RRC connection re-establishment, supporting handover

C. USER EQUIPMENT DISCONTINUOUS RECEPTION PERIOD ALGORITHM

There is no standardized DRX algorithm. Table 14 shows a pseudo-code algorithm that was found for the UE [35].

```

if (drx-Config == setup) {
  if ((Short DRX Cycle is configured/activated) &&
      (([SFN * 10] + subframe number) mod (shortDRX_Cycle) ==
       (drxStartOffset) mod (shortDRX_Cycle)) ) {
    start onDurationTimer;
  }
  if ((Long DRX Cycle is configured/activated)
      && ( [(SFN * 10) + subframe number] mod (longDRX_Cycle) == (drxStartOffset) ) ) {
    start onDurationTimer;
  }
  if ( ( a HARQ RTT Timer expires in this subframe) &&
      (data in the soft buffer of the corresponding HARQ process was not successfully decoded) )
  {
    start the drx-RetransmissionTimer for the corresponding HARQ process;
  }
  if ( DRX Command MAC control element is received ) {
    stop onDurationTimer;
    stop drx-InactivityTimer;
  }
  if ( (drx-InactivityTimer expires) ||
      (DRX Command MAC control element is received in this subframe) ) {
    if (the Short DRX cycle is configured) {
      start or restart drxShortCycleTimer;
      use the Short DRX Cycle;
    }
    else {
      use the Long DRX cycle;
    }
  }
  if ( drxShortCycleTimer expires in this subframe ) {
    use the Long DRX cycle;
  }
  if ( during the Active Time, for a PDCCH-subframe,
      if the subframe is not required for uplink transmission for halfduplex FDD UE operation and
      if the subframe is not part of a configured measurement gap ) {
    monitor the PDCCH;
    if (PDCCH indicates a DL transmission ||
        DL assignment has been configured for this subframe ) {
      start the HARQ RTT Timer for the corresponding HARQ process;
      stop the drx-RetransmissionTimer for the corresponding HARQ process;
    }
    if (the PDCCH indicates a new transmission (DL or UL) ) {
      start or restart drx-InactivityTimer;
    }
  }
  if ( not in the Active Time ) {
    CQI/PMI/RI on PUCCH and SRS shall not be reported;
  }
}

```

Table 14. User equipment DRX pseudo-code (from [35])

IV. RESULTS

Using an Ubuntu 12.0 Linux desktop virtual machine (VM) within Oracle's VM VirtualBox, the tools and current official stable release of the ns-3 network simulator was downloaded and built successfully using the instructions on the website.⁴ The tools are slightly different for download and build of an official release from those to get and build development copies of ns-3. User programs are written in either the C++ or Python programming languages and link with ns-3 libraries. The minimal software requirements to run basic simulations are a gcc/g++ installation of 3.4 or gcc-4.2 or greater, and Python 2.4 or greater. There are functions to visualize the simulations, as well as provide libpcap traces.

A suite of test programs can be run using a Python script after installation to ensure it was built correctly. The ns-3 documentation contains a basic tutorial to learn how to start using it and information on using the LTE module. Example programs can be used as a starting point for creating one's own program in a scratch directory or a series of related programs in a module. There is a very comprehensive tracing mechanism for debugging and producing output of various parameters from the simulations. In VirtualBox, a shared folder between the host computer and the ns-3 VM was created to view and graph simulation output data on the host computer.

A. NS-3 LENA MODEL SIMULATOR LIMITATIONS

The open source ns-3 network simulator was investigated as a tool but it was found that the LTE model was incomplete and did not include a complete medium access control protocol or the DRX power saving algorithm in it.

A simplified random access procedure is used in the model, meaning the control messages do not consume any actual radio resources. A protocol interference model is used so that whenever two or more identical preambles are transmitted in the same cell by multiple UEs during the same transmission time interval, neither of these identical

⁴ Installation instructions and releases of ns-3 can be found at <http://www.nsnam.org/>

preambles will be received by the eNB. This means that the contention resolution part of the random access procedure is not modeled and the UE assumes random access was successful once the UE's MAC receives the random access response from the eNB and sends the message `NotifyRandomAccessSuccessful` to the UE's RRC. Automatic initial cell selection is only available for EPC-enabled simulations, so LTE-only simulations must use the manual attachment method with the assumption that the information contained in the master information block is already known.

The MAC control elements, both header and PDU, are not accurately modeled in the simulator, only RLC and PDCP PDUs are. As a result, it is not possible to get the temporary C-RNTI from the MAC PDU. The example simulation program did print out the C-RNTI in their log file, but it was not obtained from the MAC layer PDU.

The focus of the EPC model is mainly on the data plane and on simulations of active users in ECM connected mode. Therefore, the EPC control plane is not accurately modeled as specified by 3GPP. Both radio link failure and the transition to RRC idle mode from the connected mode are missing in the simulator. Additionally, the RRC connection release in the simulator is currently never triggered by the EPC or by the NAS. This is unfortunate since RRC connection release is required by the DRX protocol in the `RRC_IDLE` State. The long DRX procedure also gets triggered when the UE switches from RRC connected to RRC idle modes, which is not implemented.

Security related aspects are not modeled, therefore SRB1 is always used and SRB2 is never activated since SRB2 is always configured by the E-UTRAN after security activation. The NAS model does not support any location update/paging procedure in idle mode, something also needed for the DRX mode.

B. LIMITATIONS OF LONG TERM EVOLUTION TRACES

The NPS Electrical Engineering department has packet traces from LTE captured using the commercially available Sanjole Wavejudge software. The free Wireshark network protocol analyzer tool indicates a capability to decode the LTE medium access control, radio link control and packet data convergence protocol headers if LTE packet

traces are captured using the dissectors for those headers. However, very little evidence was available of anyone having used it successfully.

The NPS traces were not in the libpcap file format required by Wireshark and neither was the power saving algorithm used when the traces were recorded. As a result, it was not possible to decode the traces and demonstrate that the security protocols were weak during the attach procedure or during the power saving mode.

THIS PAGE INTENTIONALLY LEFT BLANK

V. CONCLUSIONS AND FUTURE WORK

A. CONCLUSIONS

Most researchers have focused on improving LTE's performance and efficiency for the past ten years and have only recently started investigating the security vulnerabilities of LTE [5], [6], [27], [28], [36], [37]. The development of the LTE standards have taken into account the security deficiencies of prior generations of wireless communications technologies, but some researchers have theorized cyber attacks could still occur in LTE during times when those security protocols are either inactive or weak. Both [27] and [6] present a comprehensive survey of security architecture, vulnerabilities and solutions in LTE and LTE-A networks. The specific vulnerabilities in LTE often mentioned include illegal use of user and mobile equipment, location tracking, denial of service attacks and data integrity attacks. However, none of the researchers have provided any experimental data to support the claims of such vulnerabilities.

It has been suggested in some LTE security research papers that the long DRX period is one of several potential security vulnerabilities in LTE [5], [6]. Analysis of LTE standards in Section II revealed that the user's equipment can be vulnerable to a cyber attack during the network attach mode, or during the long-term power saving mode, because security protocols are either inactive or weak. It is hypothesized that if one obtains the user identity information sent in the clear during network attach, it could then be used to conduct a denial of service or data integrity attack during the long-term power saving mode.

As discussed in Section IV, the open source ns-3 network simulator was investigated as a tool to demonstrate the exploit, but it was found that the LTE model was incomplete and did not include the complete MAC protocol or the DRX power saving algorithm. Next, analysis of captured LTE packet traces available at NPS was considered. The Wireshark network protocol analyzer tool indicates a capability to decode the LTE medium access control, radio link control and packet data convergence protocol headers if LTE packet traces are captured using the dissectors for those headers. However, the

NPS LTE packet traces available were not in the libpcap file format required by Wireshark and neither was the power saving algorithm in effect when the traces were recorded by the commercially available Sanjole Wavejudge software. As a result, it was not possible to analyze if the security protocols were weak during the attach procedure or during the power saving mode.

Several limitations of the currently available tools have made it difficult to test the hypothesis at this time. Empirical data from actual measurements of LTE network traffic with the DRX algorithm is needed to analyze and design an efficient mechanism for using a UE's C-RNTI during the long DRX period in a cyber attack. The LTE standards have parameters defined for DRX but do not specify how to implement the algorithm. In fact, very few device vendors have implemented DRX, though many currently have plans to do so in the future. Appropriate laboratory testing equipment and software for analyzing LTE signals are required to demonstrate a cyber attack in LTE, both of which were not available at the time of this thesis.

B. FUTURE WORK

In order to successfully demonstrate the vulnerability of LTE to cyber attacks during the long DRX period in the future, several issues need to be resolved.

First of all, algorithms for DRX at the UE, eNB and MME need to be developed and standardized. Currently, most of the Qualcomm based LTE handsets do not fully implement the connected mode DRX feature [20], but it is not known if they implement the idle mode DRX feature. The LTE standards have provided for the DRX parameters to be exchanged between the UE, eNB and MME, but have left it up to the device vendors to implement the algorithm themselves. No open source implementations of DRX algorithms were found, indicating that they will be proprietary algorithms developed by the vendors. Without standardization of the algorithms, one would have to take into account which vendor's equipment is being used, complicating the simulations. There are currently a lot of researchers investigating efficient DRX algorithms [38].

Second, in order to use the open source ns-3 network simulator, programs for the transition from RRC connected to idle modes, the DRX algorithms and the AS security

mode command procedure would all need to be added. From discussions with the maintainers of ns-3, the conclusion was that it would take someone working full-time a couple of years to add all that code to the ns-3 simulator.

Finally, it would be worthwhile to investigate capturing actual traces of LTE packets for analysis using Wireshark's dissectors for LTE medium access control, radio link control and packet data convergence protocol headers. Without those dissectors, trying to decode the packets is extremely difficult, if not impossible. The captured LTE traces are also needed to ensure validity of the LTE module in the ns-3 network simulator.

THIS PAGE INTENTIONALLY LEFT BLANK

LIST OF REFERENCES

- [1] “Digital government: Building a 21st century platform to better serve the American people.” (2012). Federal Chief Information Officers Council, Washington, DC. [Online]. Available: <http://www.whitehouse.gov/sites/default/files/omb/egov/digital-government/digital-government-strategy.pdf>
- [2] “Department of Defense mobile device strategy.” (2012). Department of Defense, Washington, DC. [Online]. Available: <http://www.defense.gov/news/dodmobilitystrategy.pdf>
- [3] “Implementing a Nationwide, Broadband, Interoperable Public Safety Network in the 700 MHz Band.” (2011). Federal Communications Commission, Washington, DC. [Online]. Available: <http://www.gpo.gov/fdsys/pkg/FR-2011-08-18/html/2011-20831.htm>
- [4] “Long term evolution protocol overview.” (2008). Freescale, Austin, TX, Whitepaper. [Online]. Available: http://www.freescale.com/files/wireless_comm/doc/white_paper/LTEPTCLOVWP.pdf
- [5] D. Forsberg *et al.*, “Enhancing security and privacy in 3GPP E-UTRAN radio interface,” in *18th International Symposium on Personal, Indoor and Mobile Radio Communications*, Athens, Greece, 2007.
- [6] N. Seddigh *et al.*, “Security advances and challenges in 4G wireless networks,” in *Eighth Annual International Conference on Privacy Security and Trust (PST)*, Ottawa, Ontario, 2010.
- [7] *3GPP System Architecture Evolution (SAE); Security architecture*, 3GPP Technical Specification 33.401, version 11.7.0, 2013.
- [8] M. Nohrborg. (2013, September). “LTE overview.” [Online]. Available: <http://www.3gpp.org/technologies/keywords-acronyms/98-lte>
- [9] F. Firmin. (2013, November). “The evolved packet core.” [Online]. Available: <http://www.3gpp.org/technologies/keywords-acronyms/100-the-evolved-packet-core>
- [10] *General Packet Radio Service (GPRS) enhancements for Evolved Universal Terrestrial Radio Access Network (E-UTRAN) access*, 3GPP Technical Specification 23.401, version 10.10.0, 2013.

- [11] *Evolved Universal Terrestrial Radio Access Network (E-UTRAN); Architecture description*, 3GPP Technical Specification 36.401, version 11.2.0, 2013.
- [12] “LTE Tutorial.” (2013). [Online]. Available: <http://www.tutorialspoint.com/lte/index.htm>
- [13] M. Lindström, “LTE-Advanced radio layer 2 and RRC aspects,” in *3GPP LTE-Advanced Evaluation Workshop*, Beijing, China, 2009.
- [14] *Evolved Universal Terrestrial Radio Access (E-UTRA); Physical channels and modulation*, 3GPP Technical Specification 36.211 version 11.4.0, 2013.
- [15] “3GPP LTE channels and MAC layer.” (2009). [Online]. Available: www.eventhelix.com/lte/presentations/3gpp-lte-mac.pdf
- [16] *Evolved Universal Terrestrial Radio Access (E-UTRA); Medium Access Control (MAC) protocol specification*, 3GPP Technical Specification 36.321 version 11.3.0, 2013.
- [17] *Evolved Universal Terrestrial Radio Access (E-UTRA); Physical layer procedures*, 3GPP Technical Specification 36.213, version 11.4.0, 2013.
- [18] “LTE identifiers.” (2011). NMC Consulting Group, Seoul, Korea. [Online]. Available: <http://www.nmcgroups.com/files/download/NMC.LTE%20Identifiers.v1.0.pdf>
- [19] *Evolved Universal Terrestrial Radio Access (E-UTRA) and Evolved Universal Terrestrial Radio Access Network (E-UTRAN); Overall description; Stage 2*, 3GPP Technical Specification 36.300, version 11.7.0, Sept. 2013.
- [20] A. Basir. (2013). “3GPP Long Term Evolution (LTE).” [Online]. Available: <http://4g-lte-world.blogspot.com/>
- [21] *Evolved Universal Terrestrial Radio Access (E-UTRA); Radio Resource Control (RRC); Protocol specification*, 3GPP Technical Specification 36.331, version 11.5.0, Sept. 2013.
- [22] A. Roessler. (2013, September). “Test ANR functionality on your LTE devices.” [Online]. Available: <http://electronicdesign.com/test-amp-measurement/test-anr-functionality-your-lte-devices>
- [23] *Evolved Universal Terrestrial Radio Access (E-UTRA); Radio Resource Control (RRC); Protocol specification*, 3GPP Technical Specification 36.331, version 11.5.0, 2013.
- [24] F. Firmin. (2013, November). “Non-access stratum (NAS).” [Online]. Available: <http://www.3gpp.org/technologies/keywords-acronyms/96-nas>

- [25] Shisenchi. (2012, February). "Random access procedure in LTE." [Online]. Available: <http://www.teletopix.org/4g-lte/random-access-procedure-in-lte/>
- [26] M. Lazhar Belhouchet and M. Hakim Ebdelli, "Session 6: LTE/SAE mobility and session management," in *ITU/BDT Arab Regional Workshop on 4G Wireless Systems*, Tunisia, 2010.
- [27] C. B. Sankaran, "Network access security in next-generation 3GPP systems: A Tutorial," *IEEE Communications Magazine*, vol. 47, no. 2, Feb. 2009.
- [28] J. Cao *et al.*, "A survey on security aspects for LTE and LTE-A networks," *IEEE Communications Surveys and Tutorials*, vol. PP, no. 99, April 2013.
- [29] C. Bontu and E. Illidge, "DRX mechanism for power saving in LTE," *IEEE Communications Magazine*, June 2009.
- [30] P. Jodukallu. (2013, December). "Basic LTE." [Online]. Available: <http://lteshare.blogspot.com/2013/12/DRx.html>
- [31] *Evolved Universal Terrestrial Radio Access (E-UTRA) and Evolved Packet Core (EPC); User Equipment (UE) conformance specification; Part 2: Implementation Conformance Statement (ICS) proforma specification*, 3GPP Technical Specification 36.523-2, version 8.5.0, 2010.
- [32] "ns-3 web page." (2014). [Online]. Available: <http://www.nsnam.org/>
- [33] N. Baldo *et al.*, "A new model for the simulation of the LTE-EPC data plane," in *International Conference on Simulation Tools and Techniques (SIMUTools)*, Desenzano, Italy, 2012.
- [34] "The LENA ns-3 LTE module documentation release v8." (2014, Jan.). Centre Tecnològic de Telecomunicacions de Catalunya. [Online]. Available: <http://networks.cttc.es/mobile-networks/software-tools/lena/>
- [35] "MAC." (2014, May). [Online]. Available: http://www.sharetechnote.com/html/MAC_LTE.html#DRX
- [36] M. Aiash *et al.*, "Providing security in 4G systems: Unveiling the challenges," in *Sixth Advanced International Conference on Telecommunications (AICT)*, Barcelona, May 2010.
- [37] Y. Park and T. Park, "A survey of security threats on 4G Networks," in *Globecom Workshops*, Washington, DC, Nov. 2007.
- [38] Y. Mihov *et al.*, "Analysis and performance evaluation of the DRX mechanism for power saving in LTE," in *26th Convention of Electrical and Electronics Engineers in Israel (IEEEI)*, Eliat, Israel, Nov. 2010.

THIS PAGE INTENTIONALLY LEFT BLANK

INITIAL DISTRIBUTION LIST

1. Defense Technical Information Center
Ft. Belvoir, Virginia
2. Dudley Knox Library
Naval Postgraduate School
Monterey, California