

# END-TO-END MODELING WITH THE HEIMDALL CODE TO SCOPE HIGH-POWER MICROWAVE SYSTEMS\*

John A. Swegle<sup>‡</sup>

Savannah River National Laboratory, 743A  
Aiken, SC 29803  
and

James N. Benford

Microwave Sciences, Inc., 1041 Los Arabis Ln.  
Lafayette, CA 94549

## Abstract

In this paper, we describe the expert-system code HEIMDALL, which is used to model full high-power microwave systems using over 60 systems-engineering models, developed in the course of over a decade, that describe the prime and pulsed power, microwave sources, antennas, platforms, and propagation. We show an example of our calculations of the mass of a Supersystem producing 500-MW, 15-ns output pulses in the X band for bursts of 1 s, interspersed with 10-s interburst periods.

## I. Introduction to the HEIMDALL code

HEIMDALL is a code that uses expert knowledge of component technologies and the best connection of those components to estimate the performance and engineering parameters of full high-power microwave (HPM) systems, from the prime power subsystem to propagation of the output. In this regard, *performance* includes the output power, the pulse length, the repetition rate, and the intensity at a given range under different propagation conditions. The *engineering parameters* include the mass and volume of individual components and subsystems, as well as the longest linear dimension of the elements, and the total mass of the system. Although the system has a very rudimentary capability to pack subsystems together, the information provided at least greatly simplifies the task for the user of estimating the overall volume of such a system by hand. In our use of HEIMDALL, we find it has a number of useful applications, allowing us to

- Scope out systems, determining performance and estimating mass, volume, and linear dimensions;
- Examine the impact of different technology choices, using alternative technologies for the prime and pulsed power, or the HPM source, for example;
- Survey the effect of variations in key operational parameters, taking advantage of this specially-developed feature of the code to explore the tradeoffs in changing the output power or repetition rate or pulse

length, perhaps while maintaining a constant average output power.

HEIMDALL is structured hierarchically to conduct an end-to-end analysis of an HPM system problem, as indicated in Fig. 1. At the highest level, we have the *Mission*, which includes the *HPM System*, as well as the

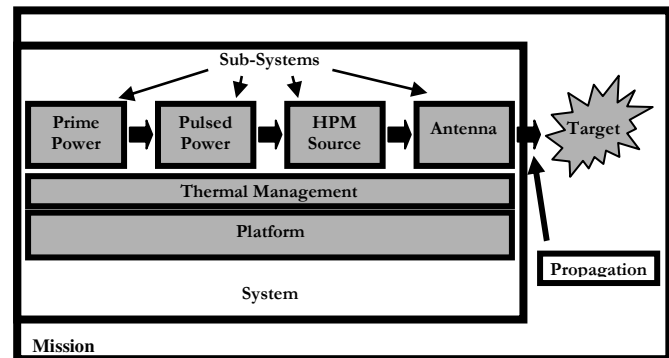

Figure 1. Conceptual structure of the HEIMDALL system model.

Propagation models to determine how much power reaches a Target. The system itself is composed of *Subsystem* models for the Prime Power, Pulsed Power, HPM Source, and the Antenna. The System also includes models for Platforms, which contain allowances for mass, volume, and dimensions when a mobile or transportable platform is involved. Less developed, but required in a full System model, would be models for a Thermal Management subsystem to handle power dissipation in repetitively-operated systems of substantial average power. HEIMDALL's graphical user interface (GUI), shown in Fig. 2, embodies this modeling approach and allows a user to build up a System to function within certain Mission requirements.

In HEIMDALL, the modeling of the System is presided over by a rules-based expert system that performs two primary tasks. First, it uses a set of rules defined using

\* Work supported by the Air Force Research Laboratory, Rome, NY, USA.

<sup>‡</sup> email: john.swegle@srl.doe.gov

## Report Documentation Page

*Form Approved*  
*OMB No. 0704-0188*

Public reporting burden for the collection of information is estimated to average 1 hour per response, including the time for reviewing instructions, searching existing data sources, gathering and maintaining the data needed, and completing and reviewing the collection of information. Send comments regarding this burden estimate or any other aspect of this collection of information, including suggestions for reducing this burden, to Washington Headquarters Services, Directorate for Information Operations and Reports, 1215 Jefferson Davis Highway, Suite 1204, Arlington VA 22202-4302. Respondents should be aware that notwithstanding any other provision of law, no person shall be subject to a penalty for failing to comply with a collection of information if it does not display a currently valid OMB control number.

|  |                                    |  |                            |                     |                                 |
|--|------------------------------------|--|----------------------------|---------------------|---------------------------------|
| 1. REPORT DATE<br><b>JUN 2007</b>  | 2. REPORT TYPE<br><b>N/A</b>       | 3. DATES COVERED<br><b>-</b>             |                            |                     |                                 |
| 4. TITLE AND SUBTITLE<br><b>End-To-End Modeling With The Heimdall Code To Scope High-Power Microwave Systems</b>   |                                    | 5a. CONTRACT NUMBER                      |                            |                     |                                 |
|  |                                    | 5b. GRANT NUMBER                         |                            |                     |                                 |
|  |                                    | 5c. PROGRAM ELEMENT NUMBER               |                            |                     |                                 |
| 6. AUTHOR(S)   |                                    | 5d. PROJECT NUMBER                       |                            |                     |                                 |
|  |                                    | 5e. TASK NUMBER                          |                            |                     |                                 |
|  |                                    | 5f. WORK UNIT NUMBER                     |                            |                     |                                 |
| 7. PERFORMING ORGANIZATION NAME(S) AND ADDRESS(ES)<br><b>Savannah River National Laboratory, 743A Aiken, SC 29803</b>  |                                    | 8. PERFORMING ORGANIZATION REPORT NUMBER |                            |                     |                                 |
| 9. SPONSORING/MONITORING AGENCY NAME(S) AND ADDRESS(ES)  |                                    | 10. SPONSOR/MONITOR'S ACRONYM(S)         |                            |                     |                                 |
|  |                                    | 11. SPONSOR/MONITOR'S REPORT NUMBER(S)   |                            |                     |                                 |
| 12. DISTRIBUTION/AVAILABILITY STATEMENT<br><b>Approved for public release, distribution unlimited</b>  |                                    |  |                            |                     |                                 |
| 13. SUPPLEMENTARY NOTES<br><b>See also ADM002371. 2013 IEEE Pulsed Power Conference, Digest of Technical Papers 1976-2013, and Abstracts of the 2013 IEEE International Conference on Plasma Science. IEEE International Pulsed Power Conference (19th). Held in San Francisco, CA on 16-21 June 2013., The original document contains color images.</b>   |                                    |  |                            |                     |                                 |
| 14. ABSTRACT<br><b>In this paper, we describe the expert-system code HEIMDALL, which is used to model full high-power microwave systems using over 60 systems-engineering models, developed in the course of over a decade, that describe the prime and pulsed power, microwave sources, antennas, platforms, and propagation. We show an example of our calculations of the mass of a Supersystem producing 500-MW, 15-ns output pulses in the X band for bursts of 1 s, interspersed with 10-s interburst periods.</b> |                                    |  |                            |                     |                                 |
| 15. SUBJECT TERMS  |                                    |  |                            |                     |                                 |
| 16. SECURITY CLASSIFICATION OF:  |                                    |  | 17. LIMITATION OF ABSTRACT | 18. NUMBER OF PAGES | 19a. NAME OF RESPONSIBLE PERSON |
| a. REPORT<br><b>unclassified</b>   | b. ABSTRACT<br><b>unclassified</b> | c. THIS PAGE<br><b>unclassified</b>      | <b>SAR</b>                 | <b>5</b>            |                                 |

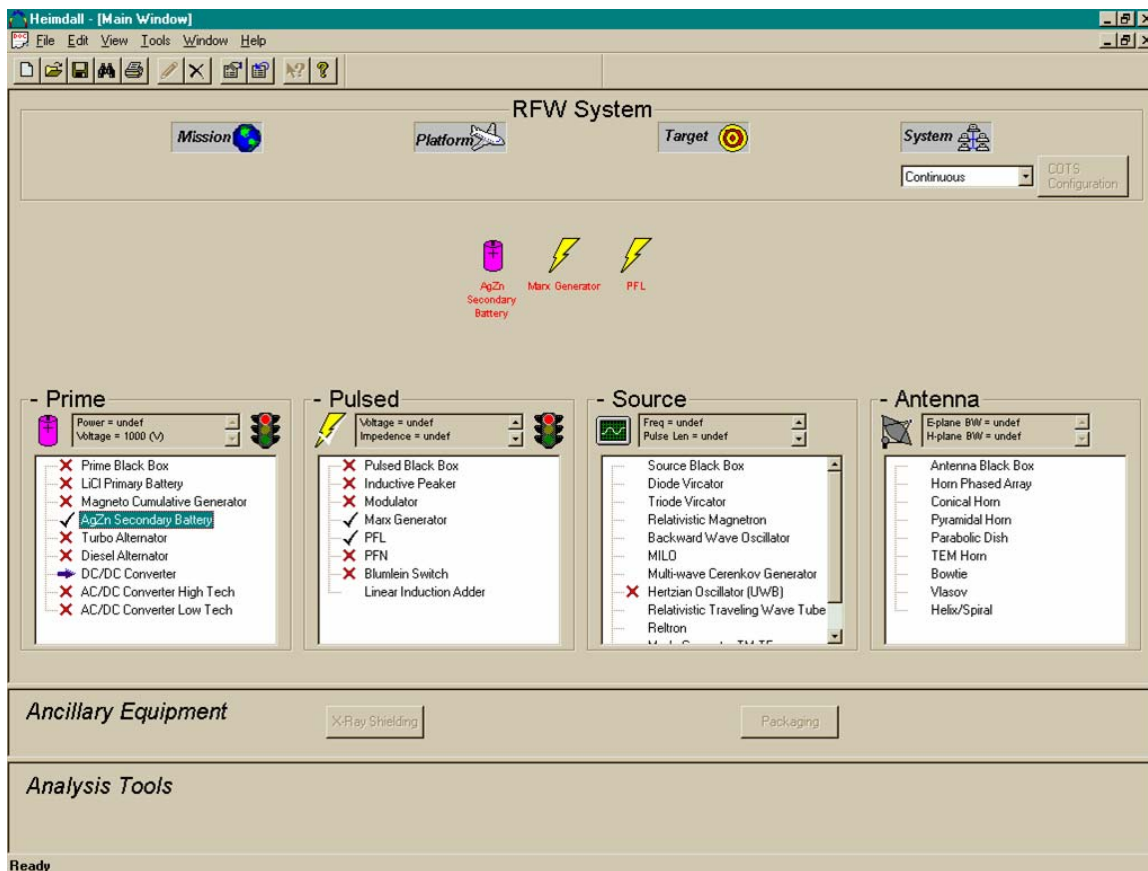

**Figure 2.** The HEIMDALL graphical user interface.

expert knowledge of the design and operation of typical systems to characterize the subsystems from a limited set of *user input* choices, relating input and output variables and generating values for mass, volume, and the longest linear dimension. Second, the expert system assists with, and enforces, the connectivity between subsystems. It suggests technology choices for the different subsystems, using models based on specific technologies, in order to properly construct the whole system. HEIMDALL also restricts the technology choices to those that will properly work together. Thus, if the user chooses a Pulse-Forming Network (PFN) as an element of the Pulsed Power subsystem, HEIMDALL might suggest that the subsystem also employ, for example, a Pulse Transformer to raise the output voltage of the PFN to the value required by the HPM Source subsystem.

HEIMDALL can model several different types of Systems. These include Single-Shot systems, as one might have in a laboratory, or a Continuous system, in which individual shots are repeated at a certain Pulse Repetition Rate (PRR). HEIMDALL also models Burst-Mode systems, in which a system fires a burst of high-power shots at a rather high PRR, drawing upon an energy storage system over the duration of the burst, such as a flywheel in the Prime Power subsystem, after which it turns off for a period to recharge, spinning up the flywheel for the next burst (in the event that a flywheel is

used). Thirdly, HEIMDALL contains models for Commercial Off-the-Shelf (COTS) systems, which includes models for whole systems as well as the capability to build a system from COTS components.

## II. HEIMDALL MODELING

Each HEIMDALL Subsystem model consists of a number of *Components*, each of which may contain a number of significant *Parts*. Thus, we note the hierarchy of System, Subsystem, Component, and Part. An example of the structure for a Subsystem model is that shown in Fig. 3 for an HPM Source. The HPM Source subsystem model lies within the gray-filled box. The user may supply *User Inputs*, shown toward the upper left of the Subsystem box. At the lower left, and at the lower right, we have two sets of *Interface Parameters*, at the input and output end of the Subsystem, respectively. Connecting to the Pulsed Power on the left (note that power flow is from left to right, as shown in Fig. 1), the interface parameters are the Voltage and Current, the Pulse Length of the pulsed-power input, and the Repetition Rate of the electrical input to the Microwave Source. Connecting to the Antenna on the right, the interface parameters are the Peak Power and Frequency of

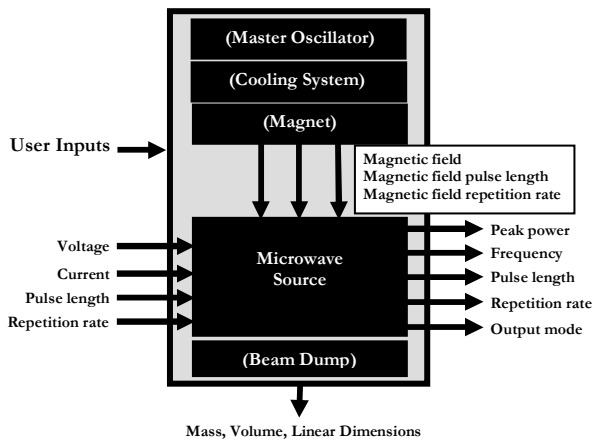

**Figure 3.** Structure of the Subsystem model for an HPM Source.

the microwave output from the Microwave Source, the pulse length of the microwave output (which will be shorter than the pulse length of the electrical input on the left) and Repetition Rate, and the Output Mode of the radiation created in the source and propagated through a waveguide to the Antenna. At the bottom, we have the *Engineering Parameters* generated by HEIMDALL, estimates of the mass, volume, and linear dimensions of the HPM Source subsystem. The actual Microwave Source is thus a component of the RF Source subsystem. Other components shown in the figure may be optional: some microwave sources require an axial magnetic field, others do not; a high-average-power RF Source may need a beam dump and cooling components, while a single-shot RF Source may not. And if the Microwave Source is

an amplifier such as a relativistic klystron or a traveling-wave tube, it may need a master oscillator. Models have been developed for these components as well, when needed. Note that in addition to the external Interface Parameters between Subsystems, there are interface parameters between components internal to a given Subsystem.

A listing of the HEIMDALL models that have been developed since 1995 by a number of contributors is shown in Table 1. An example of how the Subsystem models are interfaced is shown in Fig. 4, which shows the connection of the simple electrical models for the Pulsed Power, which is modeled as a Thevenin-equivalent voltage source, with open-circuit voltage  $V_{pp}$  and output impedance  $Z_{pp}$ . We model the RF Source electrically by the impedance  $Z_{RF}$ . The determination of  $Z_{RF}$  varies for the different models. The present models for the backward-wave oscillator (BWO) and relativistic magnetron use fixed impedances of 100 and 55  $\Omega$ , respectively. The impedance of the multiwave Cerenkov generator (MWCG), on the other hand, is based on the assumption that the device operates at a fixed, optimal cathode current density, so that the MWCG impedance depends on a user-chosen device radius and  $V_{pp}$  and  $Z_{pp}$ . As a final example, our treatment of the tunable relativistic magnetron uses a piecewise-linear model for impedance that depends on  $V_{RF}$  at voltages below 500 kV, necessitating the use of an iterative solution for  $V_{RF}$ .

HEIMDALL modeling of systems is guided by a set of *preference diagrams* that suggest the proper connection of the subsystems. An example of a Prime Power preference diagram for Burst Mode operation is shown in Fig. 5. We see that this Subsystem actually has four component parts:

| Prime Power  | Pulsed Power           | RF Source                          | Antenna              |
|--|------------------------|------------------------------------|----------------------|
| LiCl Battery   | Inductive Peaker       | Vircator                           | Conical Horn         |
| Secondary Battery  | Blumlein               | Reflex Triode                      | Pyramidal Horn       |
| Turbo-Alternator   | Modulator              | Relativistic Magnetron             | Parabolic Dish       |
| DC/DC Converter  | Marx Generator         | Tunable Relativistic Magnetron     | TEM Horn             |
| MCG  | Pulse-Forming Line     | Magnetron                          | Bowtie               |
| Turbine Transmission   | Pulse-Forming Network  | Magnetron                          | Phased Array (Horns) |
| Electric Motor/Controller  | Linear Induction Adder | MILO                               | Vlasov               |
| Hydro-Pump/Motor   | SINUS Generator        | BWO                                | Helix and Spiral     |
| Controller   | Spiral-Wound PFL       | TWT                                | COTS Antennas        |
| Flywheel Alternator  | Spiral-Wound Blumlein  | MWCG                               | TM-TE Mode Converter |
| Pulsed Alternator  |                        | Relativistic Klystron              |                      |
| Rocket MHD Generator   |                        | Reltron                            |                      |
| COTS Prime Power   |                        | Hertzian Oscillator (UWB)          |                      |
| Transformer/Rectifier  |                        | COTS Transmitters                  |                      |
|  |                        | Coherent Multi-Source Transmitters |                      |
| Also: X-Ray Shielding, Propagation Models (Free-Space, Ground-Bounce, Through Obstructions), COTS Turnkey Systems, RANETS-E, Super-RANETS, Compact Systems, NPS System |                        |                                    |                      |

**Table 1.** HEIMDALL models developed since 1995.

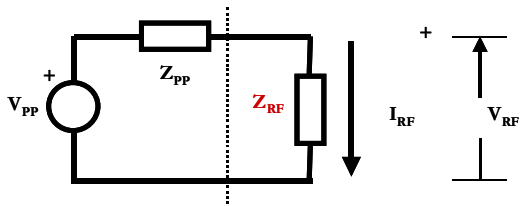

**Figure 4.** Electrical model of the Pulsed Power and RF Source connection. The dashed line shows the division between the Pulsed Power to the left and the RF Source to the right, with  $V_{PP}$  and  $Z_{PP}$  the open-circuit voltage and output impedance of the Pulsed Power and  $V_{RF}$  and  $I_{RF}$  the voltage across, current through, the RF Source impedance  $Z_{RF}$ .

a Prime Mover, an Interface between the Prime Mover and the Energy Store and Electrical Source – where energy is stored to power the system during a burst – and a Converter either to convert alternating current (AC) to direct current (DC) to charge the Pulsed Power to fire a pulse or to convert the output DC voltage from the Prime Power to the proper charging voltage for the Pulsed Power. Note that the choice of certain components rules out certain other components.

### III. THE SUPERSYSTEM: AN EXAMPLE OF HEIMDALL MODELING

In our recently published text, *High Power Microwaves, Second Edition* [1], we construct an example system that we call the Supersystem. This system has the operating parameters shown in Table 2. As indicated in the table, the system operates in the Burst Mode: the Prime Power provides power to charge the Pulsed Power over a burst of 1 s, after which the Prime Power recharges itself for 10 s. The Pulsed Power provides pulses of electricity sufficient to generate 500 MW of X-band microwave power from the Antenna in 15-ns pulses at a rate of 500 pulses per second. Thus, each burst delivers 500 pulses, with each pulse containing 7.5 J of microwave output, so that the Prime Power must deliver sufficient electrical energy to the Pulsed Power to radiate 37.5 kJ of microwave energy from the Antenna.

The Supersystem consists of the following: a Prime Power subsystem with a Turbo-Alternator, Electric Motor/Controller, Flywheel Alternator, and AC-DC Converter; a SINUS Pulsed-Power subsystem with a low-voltage capacitor bank, an integrated Tesla-transformer/pulse-forming line with a gas output switch, and a tapered transmission line to match the relatively low

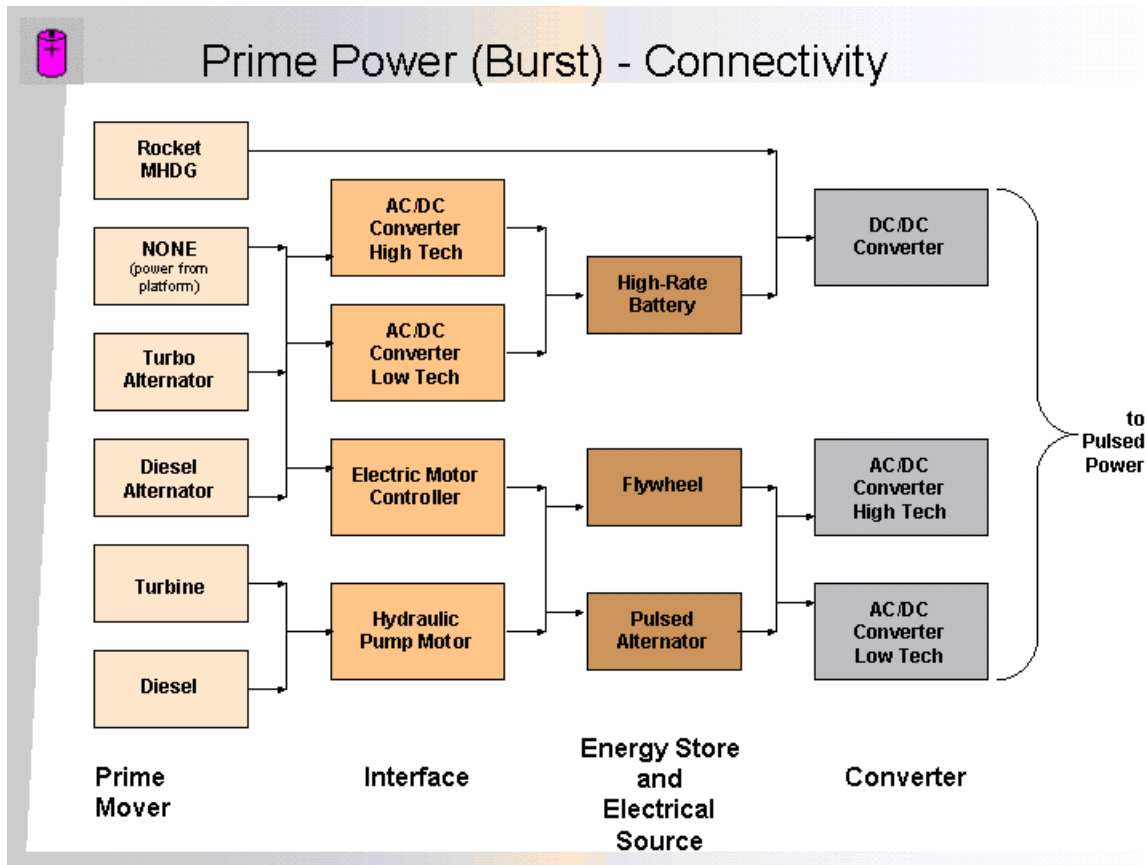

**Figure 5.** HEIMDALL preference diagram for the connection of the Prime Power subsystem when operating in the Burst Mode.

| Parameter             | Value  | Comments   |
|-----------------------|--------|--|
| Radiated Power        | 500 MW | ORION system level                                 |
| Pulse Length          | 15 ns  | Means smaller pulsed energy store                  |
| Pulse Repetition Rate | 500 Hz | Has been done for BWOs and relativistic magnetrons |
| Frequency             | 10 GHz | Much BWO experience                                |
| Antenna Gain          | 40 dB  | Sufficient for long range                          |
| Burst Duration        | 1 s    | Consistent for defense missions                    |
| Interburst Period     | 10 s   |  |

reduced length and better coupling to the load without the use of a tapered transmission line.

## V. REFERENCES

[1] J. Benford, J. A. Swegle, and E. Schamiloglu, High-Power Microwaves, 2<sup>nd</sup> Edition, Boca Raton, FL: Taylor & Francis, 2006.

**Table 2.** Operating parameters for our Supersystem.

impedance of the PFL to the higher impedance of the RF Source, which is a BWO with a superconducting magnet, followed by a TM-to-TE Mode Converter; and a Parabolic Dish Antenna. We summarize our estimate of system and subsystem masses in Table 3. Overall, system

| Subsystem    | Components  | Mass (kg) |
|--------------|---|-----------|
| Prime Power  | Turbo-Alternator<br>Electric Motor/Controller<br>Flywheel Alternator<br>AC-DC Converter | 1155      |
| Pulsed Power | Capacitor Bank<br>Tesla transformer/PFL<br>Gas Switch<br>Tapered Transmission Line      | 589       |
| RF Source    | BWO<br>Superconducting Magnet<br>TM-TE Mode Converter                                   | 17        |
| Antenna      | Parabolic Dish  | --        |

**Table 3.** Mass estimates for the Supersystem subsystems.

mass is dominated by the Prime Power, which comprises about two-thirds of the overall mass. Within the Prime Power, the Turbo-Alternator dominates in mass. The Pulsed Power is also quite heavy, dominated there by the oil-filled PFL. The Antenna is relatively light, although we did not estimate its mass for this exercise.

## IV. CONCLUSION

HEIMDALL is a mature code for systems analysis based on contributions from a number of individuals over a decade, resulting in 47 subsystem models, 5 full-system models, models for multiple platforms, and propagation models for a number of cases including free-space, ground bounce, and propagation through obstructions. By varying technology choices and operating parameters, a user can compare different system realizations. We have found in our use that these comparisons highlight technology shortcomings and point to new developments such as the spiral-wound SINUS generator, which offers