



**US Army Corps
of Engineers®**
Engineer Research and
Development Center



Engineering for Polar Operations, Logistics, and Research (EPOLAR)

Antarctic Camps Snow Drift Management Handbook

Robert Haehnel and John Weatherly

September 2014



Western Antarctic Ice Shelf Divide camp (upper left and bottom, courtesy of Dean Einerson, Antarctic Support Contractor, Centennial, CO) and Pine Island Glacier camp (upper right, courtesy of Douglas Lewis, Raytheon Polar Services Company, Centennial, CO).

Report Documentation Page

Form Approved
OMB No. 0704-0188

Public reporting burden for the collection of information is estimated to average 1 hour per response, including the time for reviewing instructions, searching existing data sources, gathering and maintaining the data needed, and completing and reviewing the collection of information. Send comments regarding this burden estimate or any other aspect of this collection of information, including suggestions for reducing this burden, to Washington Headquarters Services, Directorate for Information Operations and Reports, 1215 Jefferson Davis Highway, Suite 1204, Arlington VA 22202-4302. Respondents should be aware that notwithstanding any other provision of law, no person shall be subject to a penalty for failing to comply with a collection of information if it does not display a currently valid OMB control number.

1. REPORT DATE SEP 2014		2. REPORT TYPE		3. DATES COVERED 00-00-2014 to 00-00-2014	
4. TITLE AND SUBTITLE Antarctic Camps Snow Drift Management Handbook				5a. CONTRACT NUMBER	
				5b. GRANT NUMBER	
				5c. PROGRAM ELEMENT NUMBER	
6. AUTHOR(S)				5d. PROJECT NUMBER	
				5e. TASK NUMBER	
				5f. WORK UNIT NUMBER	
7. PERFORMING ORGANIZATION NAME(S) AND ADDRESS(ES) Cold Regions Research and Engineering Laboratory (CRREL),,U.S. Army Engineer Research and Development Center (ERDC),,72 Lyme Road,,Hanover,NH,03755				8. PERFORMING ORGANIZATION REPORT NUMBER	
9. SPONSORING/MONITORING AGENCY NAME(S) AND ADDRESS(ES)				10. SPONSOR/MONITOR'S ACRONYM(S)	
				11. SPONSOR/MONITOR'S REPORT NUMBER(S)	
12. DISTRIBUTION/AVAILABILITY STATEMENT Approved for public release; distribution unlimited					
13. SUPPLEMENTARY NOTES					
14. ABSTRACT					
15. SUBJECT TERMS					
16. SECURITY CLASSIFICATION OF:			17. LIMITATION OF ABSTRACT Same as Report (SAR)	18. NUMBER OF PAGES 108	19a. NAME OF RESPONSIBLE PERSON
a. REPORT unclassified	b. ABSTRACT unclassified	c. THIS PAGE unclassified			

The U.S. Army Engineer Research and Development Center (ERDC) solves the nation's toughest engineering and environmental challenges. ERDC develops innovative solutions in civil and military engineering, geospatial sciences, water resources, and environmental sciences for the Army, the Department of Defense, civilian agencies, and our nation's public good. Find out more at www.erdcenter.usace.army.mil.

To search for other technical reports published by ERDC, visit the ERDC online library at <http://acwc.sdp.sirsi.net/client/default>.

Antarctic Camps Snow Drift Management Handbook

Robert Haehnel and John Weatherly

Cold Regions Research and Engineering Laboratory (CRREL)
U.S. Army Engineer Research and Development Center
72 Lyme Road
Hanover, NH 03755-1290

Final Report

Approved for public release; distribution is unlimited.

Prepared for National Science Foundation
4201 Wilson Boulevard
Arlington, VA 22230

Under Engineering for Polar Operations, Logistics, and Research (EPOLAR)
EP-ANT-12-11, "Antarctic Camps Drift Management"

Abstract

Drifting snow on buildings, equipment, and tents at research camps throughout the Antarctic continent is a persistent problem. In this handbook, we provide methods to estimate the severity of the drifting problem at a proposed or an existing camp location and methods to ameliorate the drifting problems.

The guidelines provided apply to camps where the wind is predominately from one direction, typical of a large percentage of the Antarctic continent where katabatic or down slope winds are dominant. The snowdrift protection methods outlined in this handbook do not suit regions where the storm winds can come from several dominant directions.

Also included is a case study to demonstrate application of the methods outlined for estimating the severity of the drifting problem and for properly sizing the snowdrift protection system. Additionally, it provides methods to estimate the volume of snow that can be deposited during a camp season and gives examples of how to estimate the level of effort required to install the protection systems and to manage the snow throughout the camp season.

DISCLAIMER: The contents of this report are not to be used for advertising, publication, or promotional purposes. Citation of trade names does not constitute an official endorsement or approval of the use of such commercial products. All product names and trademarks cited are the property of their respective owners. The findings of this report are not to be construed as an official Department of the Army position unless so designated by other authorized documents.

DESTROY THIS REPORT WHEN NO LONGER NEEDED. DO NOT RETURN IT TO THE ORIGINATOR.

Contents

Abstract	iv
Illustrations	vii
Preface	x
Acronyms and Abbreviations	xi
Unit Conversion Factors	xiii
1 Introduction	1
2 Assessment of the Drifting Problem	4
2.1 Wind direction and magnitude.....	4
2.1.1 Sources of wind data	4
2.1.2 Analysis of wind data to determine prevailing direction	7
2.1.3 Alternate means to determine transport wind direction.....	8
2.2 Snow transport	9
2.2.1 Use of wind data to determine snow transport	9
2.2.2 Alternate methods for estimating snow transport	11
2.3 Design values of snow transport	16
2.4 Severity classification	17
3 Snow Drift Protection Systems	19
3.1 Methods to control drifting snow	19
3.1.1 Berms.....	19
3.1.2 Snow fences	21
3.1.3 Windbreaks.....	23
3.2 Sizing snow protection systems	25
3.2.1 Berms and snow fences	25
3.2.2 Windbreaks.....	27
3.3 Operational considerations	27
4 Case Study: Pine Island Glacier Camp.....	30
4.1 Determining wind direction and snow transport.....	30
4.1.1 Using AWS data	30
4.1.2 Alternate method to determine wind direction and severity class.....	33
4.1.3 Storm-scale snow transport.....	35
4.2 Determining the camp footprint (Step 6).....	38
4.3 Designing drift protection measures (Step 7)	39
4.3.1 Berm	39
4.3.2 Snow fence.....	42
4.3.3 Windbreak.....	44

4.4	Comparing protection methods and addressing considerations for application (Step 8)	45
5	Snow-fence Design for Antarctic Application	53
5.1	General fence design considerations	53
5.1.1	<i>Fence orientation</i>	53
5.1.2	<i>Fence porosity</i>	53
5.1.3	<i>Bottom gap</i>	54
5.2	Fence designs	55
5.2.1	<i>Post design</i>	56
5.2.2	<i>Truss fences</i>	59
5.2.3	<i>Anchoring</i>	61
5.3	Fence design procedure	69
5.3.1	<i>Design wind</i>	70
5.3.2	<i>Wind load</i>	71
5.3.3	<i>Resistive loads and moments</i>	73
5.3.4	<i>Anchor loads</i>	74
6	Summary and Recommendations	76
	References	79
	Appendix A: Annual Precipitation Minus Evaporation Accumulation on the Antarctic Continent	81
	Appendix B: Summary of Wind Data at the Pine Island Glacier Camp	83
	Appendix C: Summary of Estimated Transport Data at the Pine Island Glacier Camp	86
	Appendix D: Satellite Image of the Region Surrounding the Pine Island Glacier Camp	89
	Appendix E: Pressure Force Tables	90
	Appendix F: Standard Wyoming Truss Fence Design	92
	Report Documentation Page (SF 298)	94

Illustrations

Figures

1	The steps for designing snowdrift management structures for Antarctic camps*	3
2	Locations of automatic weather stations maintained on the Antarctic continent by many agencies and countries (Lazzara et al. 2013)	6
3	Example wind roses obtained for the Pegasus airfield at McMurdo Antarctica: the (a) frequency of wind direction and (b) direction and magnitude. These are for the month of October only (images and data provided by the Space and Naval Warfare Systems Command).....	8
4	Annual trends in P–E water equivalent accumulation of snow for various regions on the Antarctic continent (Cullather et al. 1998)	13
5	Trends in annual P–E accumulation by elevation for regions of the Antarctic continent (from Table 1)	14
6	Partitioning of the Antarctica continent by sector (Cullather et al. 1998)	15
7	Geometry of a snow berm and the drift that is deposited on the berm. The area protected by the berm is the triangular “protected area” behind the berm and the drift	20
8	Geometry of a snow fence and the drift that is deposited on the fence. The area protected by the fence is the triangular “protected area” behind the fence and the drift	22
9	Windbreak shelter used to protect livestock from blowing snow and wind. The windbreak can be either V shaped (shown) or semicircular but must be solid (no porosity) to work effectively to divert blowing snow. The red region indicates the approximate size of the sheltered area (after Jairell and Schmidt [1999])	24
10	Wind and transport roses for October 2008. North in these plots is true north. The wind rose indicates the percent time the wind is blowing in that direction. The transport rose indicates the percentage of total transport carried in that wind direction for that month	31
11	Trend in drift transport at the Pine Island Glacier camp through the summer months based on data taken from 2008–2011. Bar height is average if applicable, and error bars indicate range in data.....	32
12	Antarctic continent showing the location (yellow push pins) of the Pine Island Glacier met stations for 2008–2011	35
13	Time series of snowdrift transport during December 2008 based on wind data measured at the PIG AWS	36
14	Cumulative probability distribution plot of the deposited transport associated with the storms tabulated in Table 11 (n=15).....	38
15	Sketch of a berm configuration to protect the Pine Island Glacier camp from drifting snow.....	40
16	Layout of 3 m tall windbreaks to protect the camp structures	45
17	Approximate geometry of drifts formed on the storm-scale design by the end of the season. The red profile in the elevation view indicates the approximate	

geometry of the snow mound after it has been graded and feathered into the surrounding terrain. Drifts and graded snow mound are drawn to scale.....50

18 Example of standard fencing material.....54

19 Detail of snow-fence design illustrating the bottom gap and slat spacing. The bottom gap is 10%–12% of the overall height of the fence, H 55

20 A modified auger bit used for cutting in ice (Haehnel 1998). The auger shown has a 30 cm (12 in.) diameter58

21 Wyoming snow fence (a) section and (b) installed on the Ross Ice Shelf, McMurdo, Antarctica60

22 Details of the snow fence shown in Figure 21, including the anchoring system. All dimensions are in inches or degrees.....61

23 Minimum strain rate of polycrystalline ice in uniaxial creep. The variation in ice response as a function of ice temperature is illustrated by the family of curves (Budd and Jacka 1989).....62

24 Dead man anchor used for snow fences shown in Figure 21.....64

25 Configuration for anchoring in snow68

26 Probability plot of wind speed for three operational seasons at Pine Island Glacier camp (2008, 2009, and 2011). The maximum wind speed recorded over these seasons was 30.7 m/s.....70

27 Summary of recorded temperature data at the Pine Island Glacier camp72

28 Geometry and force balance of wind loads acting on a truss fence74

Tables

1 The percent of the total P–E accumulation occurring during each month, segregated by elevation.....14

2 Percent of total P–E accumulation occurring during each month, segregated by sector as depicted in Figure 515

3 Probabilities of larger values for annual snow transport expressed as design modulus K . Values in the body of the table are PE. The distribution is based on a mean of unity and $s^2 = 0.088$ (Tabler 1994)17

4 Severity classification for annual snow transport (Tabler 1994).....18

5 The size and number of berms required to handle various classes of snow transport severity. The values in the table are computed using equation (8) and $\rho_s = 350 \text{ kg/m}^3$. Berm cross-sectional area was estimated based on sides sloping at 45° and a 1 m wide top21

6 The size fence required to handle various classes of snow transport severity (Tabler 1994). All values in this table are for a snow fence that is 50% porous ($P = 0.5$).....22

7 Length of berms and snow fences required to provide a specified sheltered area (computed from equations [13], [14], and [16])26

8 Sheltered area and geometry for V-shaped and semicircular windbreaks (after Jairell and Schmidt 1999).....27

9 Location and period of operation of weather stations near the Pine Island Glacier site30

10 Transport by month near Pine Island Glacier site32

11	Summary of storm data from December 2008 and January 2009 and 2011	37
12	Summary of design information for snow drift protection using berms or a snow fence. The protected length and area for all of these designs is 150 m and 9750 m ² , respectively.....	41
13	Number of windbreaks needed to protect 9750 m ²	44
14	Estimated snow volumes that need to be moved and the level of effort to handle snow associated with drift control measures for an “optimized” camp layout. Times are based on 9-hour work days with a single operator and piece of equipment, and the Tucker can move on average 20 m ³ of snow per hour while the Caterpillar bulldozers (D6, D7, or D8) can move on average about 70 m ³ per hour	48
15	A correlation of snow hardness to snow strength provided by the International Snow Hardness Scale (Colbeck et al. 1990)	56
16	Approximate post diameters required to support 50% porous snow fences in 45 m/s (100 mph) winds. Values are for Douglas fir posts at 3.7 m on center in soil with average bearing strength of 120 kPa (Tabler 1991a)	58
17	Estimated movement of an anchor of the configuration shown in Figure 24 buried in ice to a depth of 45 cm (18 in.). Strain rate was determined from Figure 23 and deflection was determined from equation (18). This assumes the load is held nearly constant on the anchor during the load time period. Conditions shaded red represent unacceptably high anchor movement greater than 0.4cm.....	65

Preface

This study was conducted for the National Science Foundation (NSF), Division of Polar Programs (PLR), under Engineering for Polar Operations, Logistics, and Research (EPOLAR) EP-ANT-12-11, “Antarctic Camps Drift Management.” The technical monitor was George Blaisdell, Chief Program Manager, NSF-PLR, U.S. Antarctic Program (USAP).

The work was performed by Dr. Robert Haehnel and Dr. John Weatherly (Terrestrial and Cryospheric Sciences Branch, Dr. John Weatherly, Acting Chief), U.S. Army Engineer Research and Development Center, Cold Regions Research and Engineering Laboratory (ERDC-CRREL). At the time of publication, Dr. Justin Berman was Chief of the Research and Engineering Division. The Deputy Director of ERDC-CRREL was Dr. Lance Hansen, and the Director was Dr. Robert Davis.

The authors thank Doug Lewis, Pine Island Glacier Camp Manager at Raytheon Polar Services Company, Centennial, CO, for his insight on camp operations and for providing the meteorological data at that site. Also, Dr. Arnold Song, CRREL, for generating the wind and transportation roses from the meteorological data obtained at the Pine Island Glacier site. We also thank Dean Einerson, Antarctic Camps Manager, Antarctic Support Contractor, Centennial, CO, for his insight on current snowdrift problems and management strategies at USAP Antarctic camps.

COL Jeffrey R. Eckstein was Commander of ERDC, and Dr. Jeffery P. Holland was the Director.

Acronyms and Abbreviations

AFCCC	Air Force Combat Climatology Center
AMPS	Antarctic Mesoscale Prediction System
AMRC	Antarctic Meteorological Research Center
AWS	Automatic Weather Station
CRREL	Cold Regions Research and Engineering Laboratory
EOS	End of the Season
EPMD	Ethylene propylene diene monomer. A material commonly used for roofing membrane.
EPOLAR	Engineering for Polar Operations, Logistics, and Research
ERDC	Engineer Research and Development Center
GCOS	Global Climate Observing System
GSN	GCOS Surface Network
N/A	Not Available
n/a	Not Enough Information
na	Not Applicable
NR	Not Required
NOAA	National Oceanic and Atmospheric Administration
NCDC	National Climatic Data Center
NSF	National Science Foundation
PC	Percent Chance of Occurrence
PE	Probability of Exceedance
P-E	Precipitation Minus Evaporation
PIG	Pine Island Glacier

PLR	Division of Polar Programs
STP	Standard Temperature and Pressure
USAP	U.S. Antarctic Program
WAIS	West Antarctic ice Shelf
WMO	World Meteorological Organization

Unit Conversion Factors

Multiply	By	To Obtain
degrees (angle)	0.01745329	radians
degrees Fahrenheit	$(F-32)/1.8$	degrees Celsius
feet	0.3048	meters
inches	0.0254	meters
knots	0.5144444	meters per second
miles (U.S. statute)	1,609.347	meters
miles per hour	0.44704	meters per second
pounds (force) per square foot	47.88026	pascals
pounds (mass)	0.45359237	kilograms
square feet	0.09290304	square meters
tons (2,000 pounds, mass)	907.1847	kilograms

1 Introduction

On the Antarctic continent, winds frequently blow and redeposit snow. The presence of structures on the surface of the glacier promotes preferential drift deposition on or near these obstructions. This poses a problem for research field camps as the buildings, tents, and vehicles located on the surface become a snow trap, causing drifts to form within the camp. At the very least, this is a nuisance when drifts block walkways. More commonly, the drifts can block avenues of egress (e.g., doors) or bury equipment, cargo, buildings, and tents, creating a safety hazard or increasing the effort required to accomplish the research objectives.

In this handbook we provide methods on how to estimate the potential severity of the drifting problem at an Antarctic research camp and provide guidance on how to design snowdrift protection structures to minimize drift problems within the camp. The guidance provided in this document is principally to aid in laying out a field camp that has winds from a single direction (e.g., katabatic winds typical on the Antarctic continent). Designing a camp layout to protect against significant drifting that comes from two or more directions is much more complicated and is beyond the scope of this effort. Because a large portion of the Antarctic continent is influenced by katabatic winds, assuming winds coming from mainly one direction should not unduly limit the applicability of the methods outlined here.

To design a camp to minimize the impact of drifting snow, one must first identify the scope of the problem and then determine an appropriate mitigation approach based on available resources. Figure 1 illustrates the individual steps.

The remainder of this handbook describes these steps in detail. The first step, “determine the annual period of camp occupancy,” is determined by the mission of the camp and the accessibility to the site due to weather constraints (i.e., when aircraft can safely travel to the site to deliver personnel and supplies). This is fairly straightforward and is not discussed further here. In Section 2, we provide details on how to determine the prevailing direction from which the snow will be transported (Step 2) and how to assess the amount of drifting snow to expect at the proposed re-

search site (Steps 3–5). Step 6, “determine camp footprint,” relies on the site layout and what equipment, buildings, workspace, and living quarters (e.g., tents) are required to support the mission of the camp. This step is beyond the scope of this handbook but again is fairly straightforward to estimate. However, Section 2 does discuss considerations of how to lay out the camp footprint to minimize both the effects of drifting and the size of the drift control structures. In Section 3, we review snowdrift mitigation methods and provide information about the resources needed to employ these methods; one needs this information to complete Step 7. Section 4 provides a case study to demonstrate how the guidance in Sections 2 and 3 can apply to a research camp. As part of this section, we demonstrate some ways to evaluate the level of effort required to establish and to maintain the snow control method selected (Step 8). Section 5 provides additional information on snow-fence designs applicable for deployment in Antarctic camps. Section 6 gives recommendations for future work that this effort was unable to address.

Figure 1. The steps for designing snowdrift management structures for Antarctic camps*.

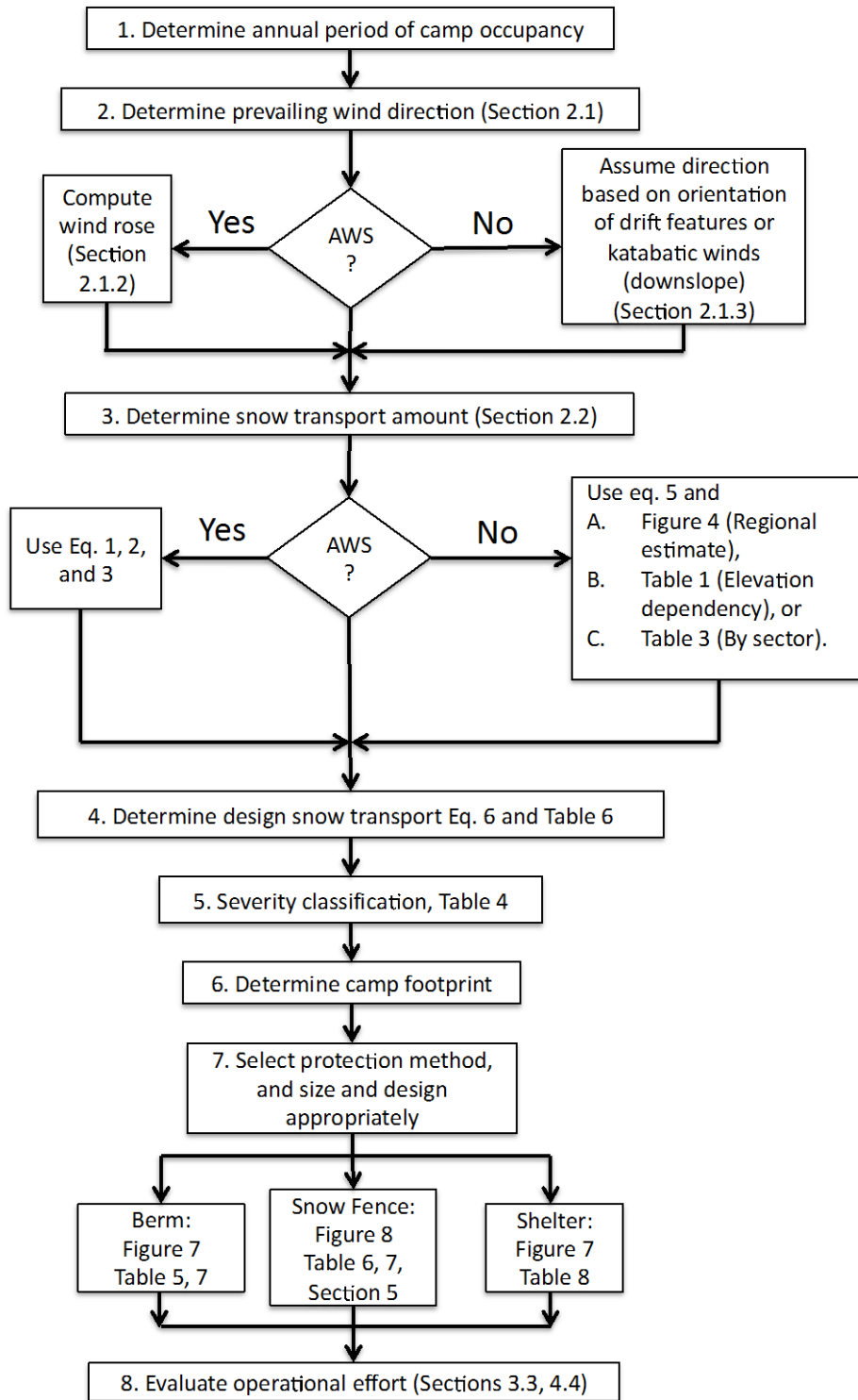

* AWS = Automatic weather station

2 Assessment of the Drifting Problem

While a camp is in operation, the predominant wind direction and the amount of snow transported by the wind are the principle factors that impact the severity of the drifting problem. The camp mission and limitations of the environment determine the duration of camp operations (Step 1, Figure 1) and are outside the scope of this handbook. This section discusses methods to determine the wind direction (Step 2, Figure 1) and snow transport amount (Steps 3–4, Figure 1) and a severity classification (Step 5, Figure 1) used to simplify drift control design.

2.1 Wind direction and magnitude

The prevailing surface winds over the Antarctic continent are gravity-driven downslope (or katabatic) winds from the high-elevation plateau towards the coasts. However, the strength and direction of the katabatic winds are also influenced by local topography (e.g., the slope of the landscape and obstructing peaks and valleys), creating local differences in the prevailing winds. Over the ice sheet, these winds create frequent blowing snow conditions and low visibility near the surface even when little net precipitation is occurring.

For potential field sites on the Antarctic continent, surface observations from existing stations in the nearby region will be the most representative for estimating the surface winds (and likely blowing snow impacts). Most important are the wind direction and magnitude for the period the camp will be maintained at the site (e.g., December through January). Hourly data, where available, are best.

2.1.1 Sources of wind data

The observational wind data are available in three forms (listed in order of preferred data):

1. Station climatologies (from longer-term sites)
2. Short-term automatic weather station data
3. Forecast model output

Below, we discuss each of these sources in turn.

2.1.1.1 *Climatological data*

The surface wind climatologies, containing tabulated statistical mean wind speeds, mean direction, and peak gusts, exist for stations that began observations as early as the 1958 International Geophysical Year. If a field site is in reasonable proximity to these stations, these data have the longest period of record for estimating the expected monthly mean winds. The data are available from two sources:

- The National Oceanic and Atmospheric Administration (NOAA) National Climatic Data Center (NCDC), Asheville, NC, (<http://www.ncdc.noaa.gov/oa/ncdc.html>) has climatological data in the GCOS (Global Climate Observing System) Surface Network (GSN), which has monthly climatology for many of the long-term Antarctic stations.
- The U.S. Air Force 14th Weather Squadron (formerly the Air Force Combat Climatology Center [AFCCC], <https://notus2.afccc.af.mil/SCISPublic/>), has much of the same data as NCDC above available in the Operational Climatic Data Summary with monthly mean winds, peak winds, and direction for the long-term established World Meteorological Organization (WMO) stations from all countries, not just the U.S.

However, these established stations are mostly around the Antarctic coasts, with exceptions such as South Pole stations (Amundsen-Scott Base and Nico) and at Dome C.

2.1.1.2 *Antarctic AWS stations.*

The University of Wisconsin's Antarctic Meteorology Research Center (AMRC, see <http://amrc.ssec.wisc.edu/data/>) have deployed and maintained a large number of AWSs. Figure 2 shows the locations of the AWS sites that are either maintained or archived by AMRC. They record temperatures, wind speeds, and direction in intervals of seconds to minutes. The advantage of the AWSs is that they have been deployed at many sites across the interior. The disadvantage is that some locations have periods of records of only one or two field seasons and do not necessarily operate every month.

Figure 2. Locations of automatic weather stations maintained on the Antarctic continent by many agencies and countries (Lazzara et al. 2013).

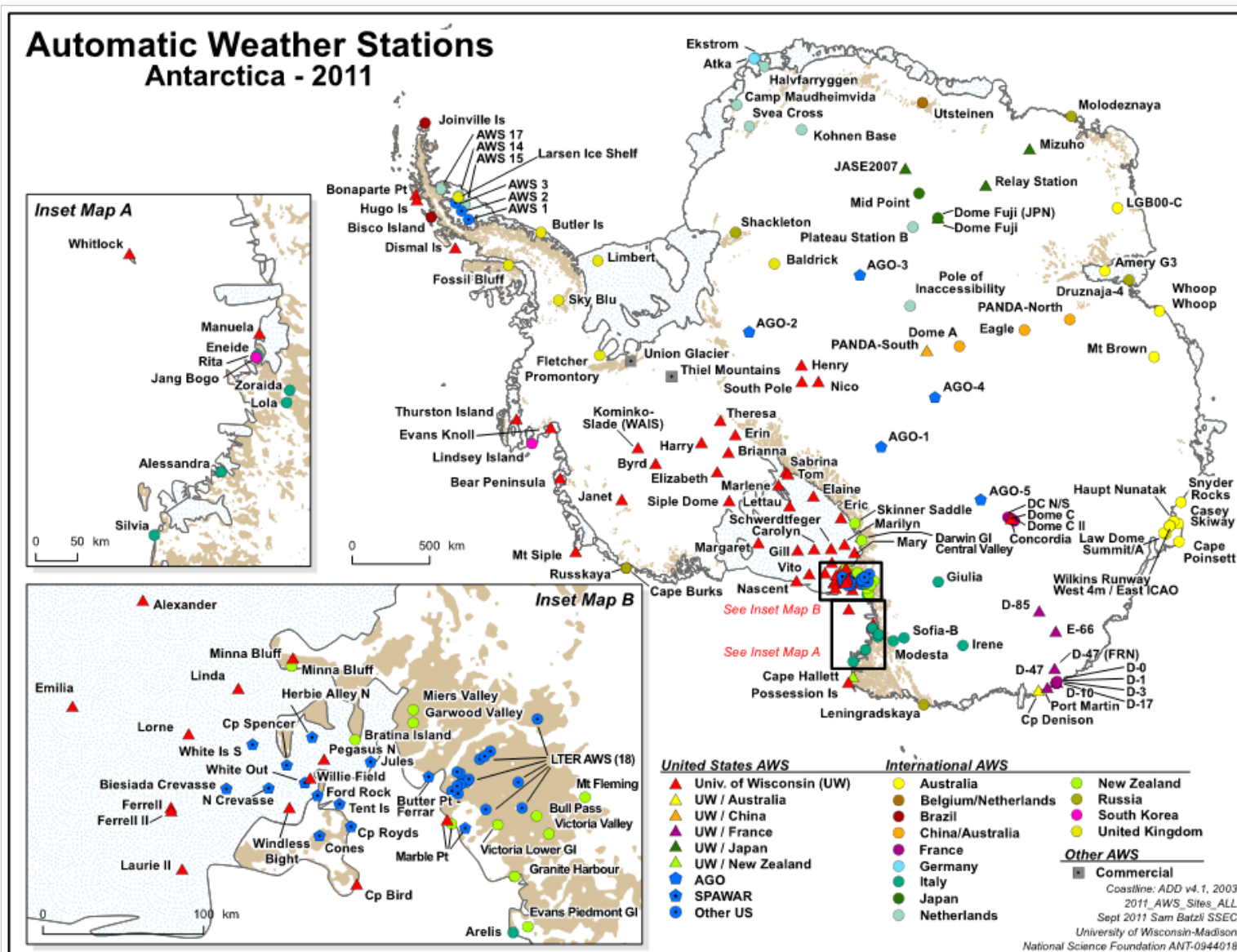

2.1.1.3 *Model-derived winds*

For estimating surface winds in a location where no station observation or AWS data have been recorded, the surface winds can be pulled from the mesoscale model forecasts of the Antarctic Mesoscale Prediction System (AMPS, see <http://www.mmm.ucar.edu/rt/amps/>) (Bromwich et al. 2003). The model grid at the 15 km resolution covers the entire continent, with a 1.7 km grid for Ross Island and the surrounding region. While the AMPS forecasts do not create a full climatology, the model output over a season could be reanalyzed to provide a non-validated estimate of mean surface winds in a region where no recent observations have been made.

If there is sufficient lead time (one full season) prior to planning operations, the model forecasts for one or more potential sites can be extracted from the AMPS for an estimate of surface winds from ongoing forecasts.

2.1.2 **Analysis of wind data to determine prevailing direction**

Once the wind data are obtained, a wind rose over the period that the camp will be operational can be determined, either directly from climate records or constructed from the available data. This will provide an initial sense of the variability and magnitude of the winds in the region and the potential suitability of snow management methods for the site. If the wind rose reveals the wind direction is from a single dominant direction, it should be relatively easy to implement a strategy for controlling snow drifting; and any snow control structure can be placed upwind of the site as dictated by the wind record.

However, it is not uncommon in some locations to have a bi-modal wind distribution with a prevailing, weaker wind coming from one direction while a stronger storm wind comes from another direction. In this case, it may be that the storm wind carries most of the drifted snow, and only one direction need be considered.

To illustrate, Figure 3 shows example wind roses created for the Pegasus airfield. Figure 3a plots the directional frequency. This shows prevailing wind to be from about 60° to 70°. Unfortunately, relying on frequency data alone gives an incomplete picture of the conditions, and Figure 3b gives a more useful representation of the wind data. Here, the frequency of direction coupled with wind speed is used to create the wind rose. This shows that there are two important wind directions to consider. The first is the

prevailing wind (60° – 70° , also identified in Figure 3a). However, Figure 3b shows that the winds associated with the prevailing wind are typically “Light” and less than 10 knots. The second mode is from 160° to 180° and has winds of 15–20 knots. The snow transport rate is a strong function of wind speed; so though the frequency of these winds is substantially lower than the prevailing winds, the magnitude is higher and, therefore, is responsible for most of the snow transported at this site.

Figure 3. Example wind roses obtained for the Pegasus airfield at McMurdo Antarctica: the (a) frequency of wind direction and (b) direction and magnitude. These are for the month of October only (images and data provided by the Space and Naval Warfare Systems Command).

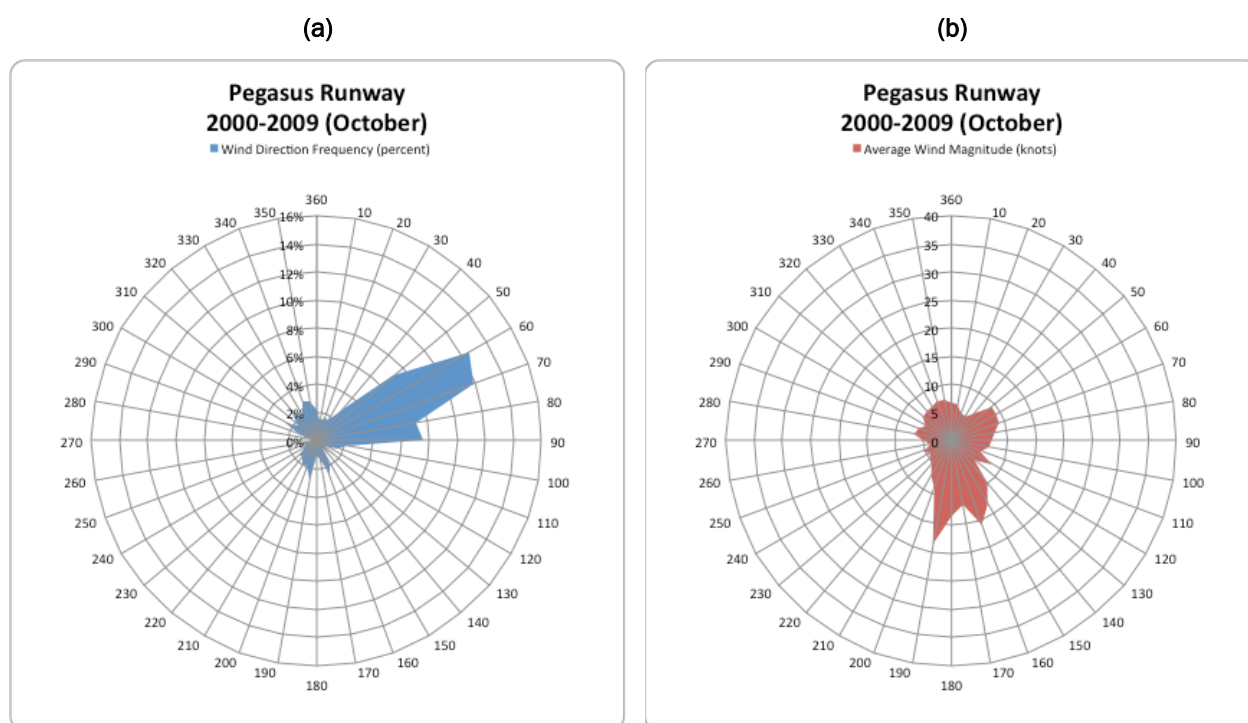

2.1.3 Alternate means to determine transport wind direction

In the absence of good quality meteorological data, one can use other means to estimate the transport direction and quantity. The dominant transport wind direction can be determined from the orientation of snow-drift features via ground or aerial surveys. Longitudinal drift forms, such as sastrugi ridges, will be aligned parallel to the dominant wind direction while barchan, or crescent-shaped, drift formations will be perpendicular to the wind. If there are structures in the field (e.g., buildings, cargo boxes, posts) the leeward drifts will be aligned with the wind. Use of the orientation of local drift features when present will provide a more reliable indica-

tion of wind direction than assuming the katabatic wind direction, especially if local effects turn the wind to some degree from the predominate downslope direction.

2.2 Snow transport

To properly design a snow management strategy, one needs to determine the quantity of snow transported by the wind. While it is preferable to use direct measurements, such as snow traps, to determine these quantities, such measurements are labor intensive and seldom made. Therefore, the following sections discuss some alternative methods for obtaining snow transport calculations.

2.2.1 Use of wind data to determine snow transport

When available, wind data can be used to estimate the amount of snow transported at the site. Tabler (1991b) provides a correlation between wind speed and the snow transport rate for the first 5 m above the ground, q (kg/m-s):

$$q = \frac{U_{10}^{3.8}}{233846} \quad (1)$$

where U_{10} (m/s) is the observed wind speed at 10 m above the ground, which is typically the reported “surface” wind in meteorological records and computer models. Using equation (1) with the wind records allows us to compute a transport amount for each recorded time, q_i . To get the total transport, Q (kg/m), over a period of time, we need to sum up individual snow transport rates over the period of interest:

$$Q = \Delta t \sum_{i=1}^n q_i \quad (2)$$

where Δt is the reporting interval (e.g., hourly, 3-hour, daily) of the met data and n is the number of wind observations in the period of interest. Note that the shorter the observation time interval (e.g., hourly), typically the more accurate the application of equations (1) and (2) will be for estimating the snow transport.

We note that frequently the average and maximum (or gust) wind speed is logged for the reporting interval (e.g., hourly or daily). Using the maximum reported wind speed in equation (1) will vastly over estimate the transport, especially if Δt is large, as the maximum values are typically sus-

tained for only a small portion of the reported interval (e.g., a few seconds). Applying the average wind speed will provide a more reasonable estimate of the transport, though if the average is over a long time period (> 3 hours), it may underestimate the transport. Because the transport is dependent on nearly the fourth power of wind speed (equation 1), small increases in the wind speed over the mean value can produce large increases in the transport (e.g., doubling the wind speed increases the transport by a factor of 14). To minimize inaccuracies in estimating snow transport, preferably the reporting interval is 1 hour or less as this better captures the variations in the wind speed over the blowing snow event, thereby reducing error in the estimated transport.

Application of equations (1) and (2) gives an estimate of the total amount of snow picked up by the wind, provided that there is an unlimited snow supply (i.e., there is always loose snow that is available to be blown). This points out the disadvantage of using equation (1) alone as there may be times when a substantial wind is blowing but there is no loose snow available. Therefore, application of equations (1) and (2) gives a conservative upper limit for the amount of snow picked up by the wind.

A proportion of the snow transported by the wind is lost to sublimation while it is airborne. So, the wind does not deposit into drifts all of the snow it picks up; about 30% of the snow is lost to sublimation, and the deposited amount, Q_{dep} is approximately (Tabler 1994)

$$Q_{dep}=0.7 Q. \quad (3)$$

We assume that equation (3) will be sufficient for most applications in Antarctica where the unobstructed field (or fetch) upwind of the camp is essentially infinite (>6000 m) because with any fetch longer than 6000 km, the snow will evaporate before it reaches the site (Tabler 1994). However, there may be some cases where the upwind fetch is less than 6000 m. When this is the case, equilibrium transport is not achieved before reaching the site, and the following correction is needed (Tabler 1994):

$$Q_{dep}=0.7 Q(1-0.14^{F/3000m}) \quad (4)$$

where F is the upwind distance from the camp to the nearest land feature that forms an obstruction to drifting snow (e.g., the edge of the ice shelf,

open water, deep gullies, or a mountain range). In the case of an infinite fetch ($F \geq 6000$ m); equation (4) reduces to equation (3).

Using the wind data and equations (1) to (4) as appropriate, a transport rose (analogous to a wind rose) can be produced. This is similar to the wind rose shown in Figure 3a; however, wind magnitude is replaced by the computed transport magnitude. The result provides an estimate of seasonal transport and the prevailing transport direction. We show the results of such an analysis in Section 4 (Figure 10)

2.2.2 Alternate methods for estimating snow transport

Accurately estimating the snow transport in the absence of wind data is more problematic. However, determining the upwind fetch length and the accumulated snow, S_{we} , in water equivalent depth at a location where there is some information about how much snow accumulates during the operational season can help to obtain a rough order-of-magnitude estimate.

Then the estimated transport is determined from

$$Q = \rho F S_{we} \quad (5)$$

where $\rho = 1000$ kg/m³ is the density of water. The deposited transport can then be computed by applying equation (3) or (4) as appropriate.

The fetch length is relatively simple to determine. It is the upwind distance from the site to the nearest obstruction to drifting snow. This can be determined from aerial photographs or field surveys. As discussed above, snow that is picked up by the wind more than 6 km from the camp evaporates before reaching the camp. Therefore the maximum fetch length used for calculating snow transport is 6 km.

Once the fetch is determined, an estimate for the accumulated snow depth over the time of interest needs to be obtained. Getting a reliable estimate of S_{we} for the Antarctic continent is problematic, however. Because most of the snow is redistributed by winds, precipitation records, if available at all, are subject to considerable error. What is commonly reported is net accumulation over a period of time, specifically the total change in water equivalent snow depth on the ground at a location due to snow accumulation by precipitation and subsequent drifting and evaporation. This is referred to as the P–E (precipitation minus evaporation) accumulation. For a remote site that lacks such observations, it may be difficult to determine

this depth. However, there is some climate data available that provides insight into how the P–E accumulation varies across the continent (e.g., Giovinetto and Bentley [1985], Cullather et al. [1998], Vaughan et al. [1999]). Appendix A includes contour plots of P–E data. Typically, P–E accumulation tends to be highest near the coasts (S_{we} as high as 500–600 mm/year) and declines moving toward the interior, with the central portions having accumulations of $S_{we} \leq 50$ mm/year. However, what is more germane to this application is the P–E accumulation just during the period of operation of the camp.

Figure 4 shows the variation in the annual trend in P–E accumulation for selected regions on the Antarctic continent. This shows that the annual trends can vary widely across the continent; therefore, use of continent-wide average trends can introduce considerable error. To address the regional variation, Cullather et al. (1998) subdivided the continent by elevation (Table 1) and sectors (Figure 6 and Table 2) in an attempt to provide characteristic trends descriptive of portions of the continent. To visualize the trends presented in Table 1, Figure 5 presents a plot of these trends. This shows that, in general, the bulk of the accumulation occurs during the winter months with relatively little accumulation during the summer (November–February).

Using the data of Cullather et al. (1998), we propose the following method for estimating the P–E accumulation during an operational season:

1. Using the data presented in Appendix A, estimate the annual accumulated S_{we} based on the P–E accumulation for the location of interest.
2. Determine the percent of the annual total that corresponds to the operational season by summing up the percentages from Tables 1 or 2 for regions of interest over the months of interest and multiplying this summation by the annual total. For example, if the annual total for a locale, as determined from the figures in Appendix A, is 150 mm/year (0.15 m/year); the operational season spans November through January; and the region is in Sector A, then the operational season has a S_{we} accumulation that is November + December + January = 5.58 + 4.40 + 2.54 = 12.5% of the total annual accumulation or $S_{we} = 12.5\% \times 0.15 \text{ m} = 0.019\text{m}$. Input this value of S_{we} into equation (5) to determine an estimate of the snow transport, Q , over the operational season.

Figure 4. Annual trends in P-E water equivalent accumulation of snow for various regions on the Antarctic continent (Cullather et al. 1998).

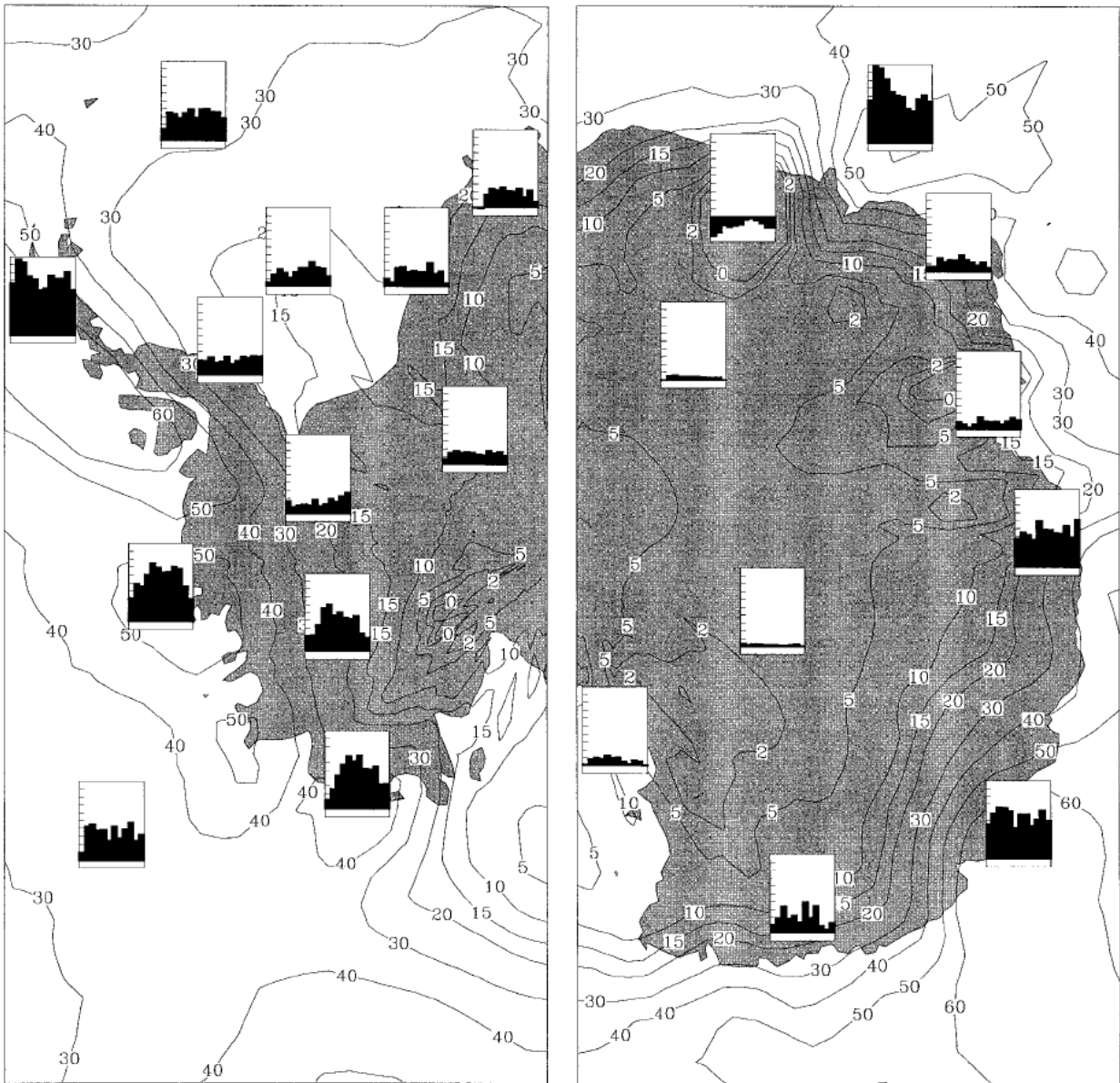

Table 1. The percent of the total P-E accumulation occurring during each month, segregated by elevation.

Month	Percent of the Annual Total		
	Entire Continent	>1500 m	>2500 m
Jan.	5.02	3.67	1.76
Feb.	7.12	6.97	7.21
Mar.	8.71	9.28	10.82
Apr.	9.98	11.01	11.74
May	10.01	10.59	10.99
Jun.	9.78	10.74	11.58
Jul.	10.61	12.05	12.16
Aug.	9.50	10.43	10.65
Sep.	9.53	9.70	9.73
Oct.	8.31	7.76	8.56
Nov.	6.21	4.61	4.19
Dec.	5.22	3.20	0.59

Figure 5. Trends in annual P-E accumulation by elevation for regions of the Antarctic continent (from Table 1).

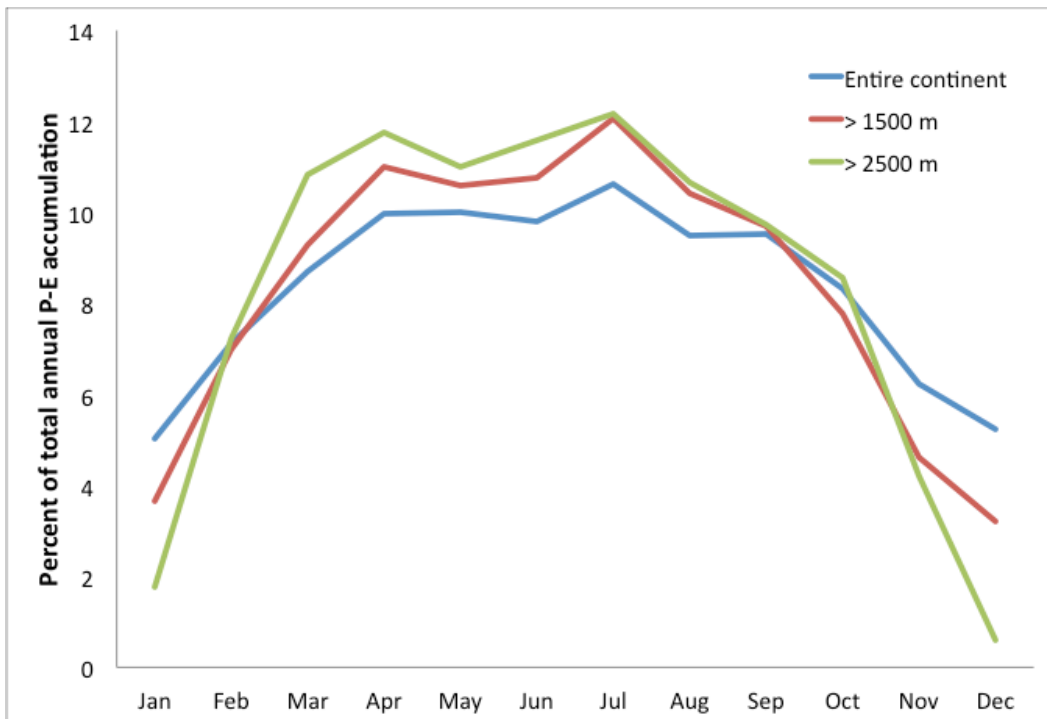

Figure 6. Partitioning of the Antarctica continent by sector
(Cullather et al. 1998).

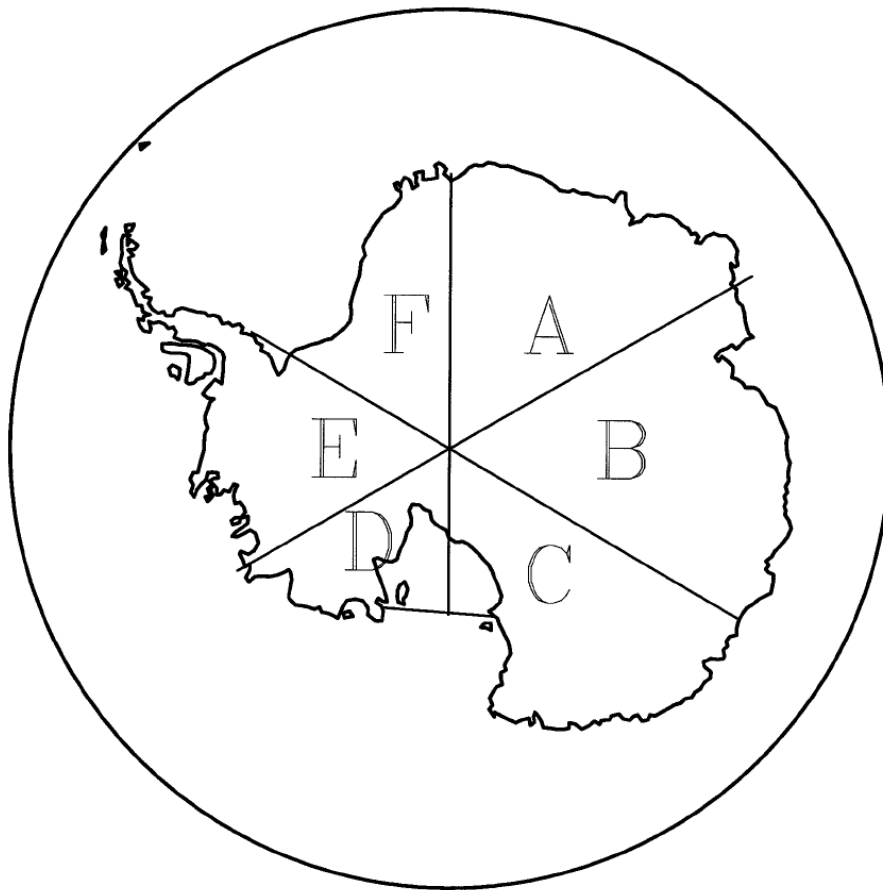

Table 2. Percent of total P-E accumulation occurring during each month, segregated by sector as depicted in Figure 5.

Month	Percent of Annual Total					
	A	B	C	D	E	F
Jan.	2.54	6.92	4.88	3.48	6.10	3.60
Feb.	9.14	8.12	8.72	5.16	6.10	4.33
Mar.	11.68	7.64	8.83	8.05	7.94	10.03
Apr.	11.84	8.35	10.18	10.53	9.89	10.28
May	10.83	8.47	8.41	14.06	10.47	9.55
Jun.	8.80	10.14	9.14	11.82	9.15	10.52
Jul.	11.84	10.85	13.29	11.33	8.31	7.97
Aug.	8.97	9.78	11.01	8.13	9.26	9.06
Sep.	6.77	8.71	11.11	7.65	10.52	11.73
Oct.	7.61	7.88	6.54	8.61	10.15	8.33
Nov.	5.58	6.33	4.15	5.96	6.94	8.82
Dec.	4.40	6.81	3.74	5.24	5.16	5.78

2.3 Design values of snow transport

After determining the estimated average amount of snow that can deposit at the site (Q_{dep}), one must establish a design value, Q_{des} , that provides a factor of safety, or design modulus, K , associated with extreme events where

$$Q_{des} = KQ_{dep}. \quad (6)$$

The value of K is determined based on the acceptable risk associated with the design. Risk is quite often framed in terms of the probability of exceeding (PE) the design value, with lower values of PE being associated with larger values of K . To determine K we follow the guidance provided by Tabler (1994), suggesting that the probability distribution of snow transport is consistent with hydrological variables and that the modular coefficients of the transport distribution are the mean of 1.0 and variance, $s^2 = 0.088$. Values of K can be determined based on acceptable PE for the design and by using Table 3 (Tabler 1994).

To find an appropriate value of K , one must first establish an acceptable PE. This is based on the acceptable risk associated with the snowdrift protection system being overwhelmed. While the details of such a risk analysis are beyond the scope of this work, a typical value is $PE = 0.05$, which is interpreted as a 5% probability of the snow transport exceeding the design value. Because $PE = 0.05$ suggests that the design value would be exceeded on average once every 20 years, this may be an adequate starting value for many camp designs. However, when determining the PE value for a particular camp, one must seriously consider the risks associated with the design condition being exceeded. The higher the risks (or costs) associated with exceeding design conditions, the lower the PE values should be when developing the design.

The value of $PE = 0.05$ is found in the body of Table 3, and a corresponding value of K is extracted. In this case, the nearest value in the table to $PE = 0.05$ is $PE = 0.0493$. Using this value we find $K \approx 1.49$. We would use this in equation (6) to determine the design snow transport for this example.

Table 3. Probabilities of larger values for annual snow transport expressed as design modulus K . Values in the body of the table are PE. The distribution is based on a mean of unity and $s^2 = 0.088$ (Tabler 1994).

K	0.00	0.01	0.02	0.03	0.04	0.05	0.06	0.07	0.08	0.09
0.0	0.9996	0.9996	0.9995	0.9995	0.9994	0.9993	0.9992	0.9991	0.9990	0.9989
0.1	0.9988	0.9987	0.9985	0.9983	0.9981	0.9979	0.9977	0.9974	0.9971	0.9968
0.2	0.9965	0.9961	0.9957	0.9953	0.9948	0.9943	0.9937	0.9931	0.9924	0.9917
0.3	0.9909	0.9900	0.9891	0.9880	0.9870	0.9858	0.9845	0.9832	0.9817	0.9801
0.4	0.9784	0.9766	0.9747	0.9727	0.9705	0.9681	0.9656	0.9630	0.9602	0.9572
0.5	0.9541	0.9507	0.9472	0.9434	0.9395	0.9354	0.9310	0.9264	0.9216	0.9165
0.6	0.9112	0.9057	0.8999	0.8939	0.8875	0.8810	0.8741	0.8670	0.8596	0.8520
0.7	0.8441	0.8359	0.8274	0.8186	0.8096	0.8003	0.7908	0.7809	0.7708	0.7605
0.8	0.7499	0.7391	0.7280	0.7167	0.7052	0.6934	0.6815	0.6694	0.6571	0.6446
0.9	0.6320	0.6192	0.6063	0.5933	0.5801	0.5669	0.5536	0.5403	0.5269	0.5134
1.0	0.5000	0.4866	0.4731	0.4597	0.4464	0.4331	0.4199	0.4067	0.3937	0.3808
1.1	0.3680	0.3554	0.3429	0.3306	0.3185	0.3066	0.2948	0.2833	0.2720	0.2609
1.2	0.2501	0.2395	0.2292	0.2191	0.2092	0.1997	0.1904	0.1814	0.1726	0.1641
1.3	0.1559	0.1480	0.1404	0.1330	0.1259	0.1190	0.1125	0.1061	0.1001	0.0943
1.4	0.0888	0.0835	0.0784	0.0736	0.0690	0.0646	0.0605	0.0566	0.0528	0.0493
1.5	0.0459	0.0428	0.0398	0.0370	0.0344	0.0319	0.0295	0.0273	0.0253	0.0234
1.6	0.0216	0.0199	0.0183	0.0168	0.0155	0.0142	0.0130	0.0120	0.0109	0.0100
1.7	0.0091	0.0083	0.0076	0.0069	0.0063	0.0057	0.0052	0.0047	0.0043	0.0039
1.8	0.0035	0.0032	0.0029	0.0026	0.0023	0.0021	0.0019	0.0017	0.0015	0.0013
1.9	0.0012	0.0011	0.0010	0.0009	0.0008	0.0007	0.0006	0.0005	0.0005	0.0004
2.0	0.0004	0.0003	0.0003	0.0003	0.0002	0.0002	0.0002	0.0002	0.0001	0.0001

2.4 Severity classification

To provide context for the design value, Tabler (1994) provides a severity classification for the amount of snow transport, ranging from “Very light” to “Extreme.” Table 4 summarizes this classification. Once Q_{des} is determined, the classification provides a gauge as to the relative severity of the drifting problem; and the next section uses this for sizing snow control solutions.

Table 4. Severity classification for annual snow transport (Tabler 1994).

Class	Snow Transport (t/m)	Description
1	<10	Very light
2	10–20	Light
3	20–40	Light to moderate
4	40–80	Moderate
5	80–160	Moderately severe
6	160–320	Severe
7	>320	Extreme

1 t = 1000 kg

3 Snow Drift Protection Systems

3.1 Methods to control drifting snow

There are several methods suitable for controlling snow drifting in remote locations with little to no topographic relief and with limited resources (personnel and equipment) and materials. These are berms, snow fences, and snow shelters or windbreaks. We will discuss each of these in turn.

3.1.1 Berms

A berm can be constructed using snow and a piece of equipment capable of mass snow transport available at the site (e.g., Dozer, Tucker, or other bladed equipment). Figure 7 shows the geometry of a snow berm, which is constructed perpendicular to the transport wind direction. The amount of transported snow that the berm captures is approximately

$$Q_{\text{captured}} = \eta Q_{\text{des}} = \frac{1}{2} \rho_s 6H^2 \quad (7)$$

where $\rho_s = 350\text{--}400 \text{ kg/m}^3$ is the density of the windblown snow compacted into the drift, H is the height of the berm (Figure 7), and η is the capture efficiency of the berm, which varies with the height of the berm: $\eta = 0.85$ for $H \leq 1 \text{ m}$ and $\eta = 0.90$ for $H \geq 2 \text{ m}$ (Tabler 1994). What this means is that 10%–15% of the design snow transport gets by the berm and will need to be managed within the camp. Furthermore, to prevent equipment, tents, etc., from being buried by the drift that forms behind the berm, these need to be located a distance at least $6H$ downwind of the berm in the triangular region indicated in Figure 7 as “protected area.”

From a design point of view, it is valuable to know the height of the berm required to handle the design transport. For this, equation (7) becomes

$$H = \sqrt{\frac{Q_{\text{des}} \eta}{3\rho_s}} \quad (8)$$

Using equation (8) we can estimate the height of berm needed to capture the design snow transport.

Figure 7. Geometry of a snow berm and the drift that is deposited on the berm. The area protected by the berm is the triangular “protected area” behind the berm and the drift.

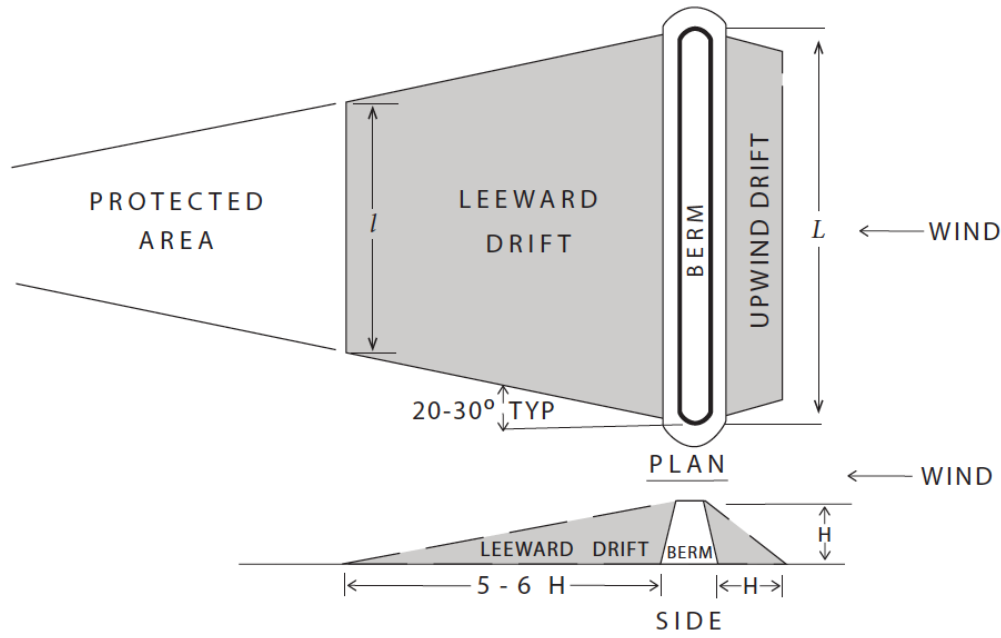

In Table 5, we provide a summary of the size and number of berms required for protection based on the severity class identified in Table 4. For this we consider it unreasonable to build a berm higher than 4 m and, due to the effort required to build the individual berms, limit the number of berms constructed to 8 or less. Table 5 shows that for all but the lowest amount of snow transport (Class 1 and 2), a site needs more than one snow berm to protect it. When more than one berm is needed, the berms need to be placed far enough apart to prevent the drift from the upwind berm overlapping the downwind berm. The right most column in Table 5 provides the minimum spacing required between parallel berms if using more than one row of berms. In the case of multiple berms, they are constructed parallel to each other, extending in the upwind direction from the camp. Section 4.3.1 further illustrates this configuration.

Snow berms have the advantage of using in situ resources to control snow drifting. However, the amount of snow deposited around a berm (i.e., its trapping capacity) is relatively small in comparison to a properly designed snow fence.

Table 5. The size and number of berms required to handle various classes of snow transport severity. The values in the table are computed using equation (8) and $\rho_s = 350 \text{ kg/m}^3$. Berm cross-sectional area was estimated based on sides sloping at 45° and a 1 m wide top.

Classification	Snow Transport (t/m)	Height (m)	Number Required	Spacing or Setback (m)	Estimated Berm X-sectional Area (m ²)
1: Very light	<10	2	2	14	6
		3	1	21	12
2: Light	10–20	3	2	21	12
		4	1	28	20
3: Light to moderate	20–40	3	4	21	12
		4	2	28	20
4: Moderate	40–80	4	4	28	20
5: Moderately severe	80–160	4	8	28	20

3.1.2 Snow fences

Figure 8 shows the geometry of a snow-fence system. As indicated in the figure, these are also placed perpendicular to the snow transport direction. The amount of snow trapped by a snow fence is

$$Q_{des} = (3 + 4P + 44P^2 - 60P^3)H^{2.2} \quad (9)$$

where P is the porosity of the fence, Q_{des} has units of t/m, and H is in meters (Tabler 1994). The trapping efficiency of a snow fence is very nearly unity until it reaches saturation. Maximum capture capacity is achieved for $P = 0.5$; we use this value for fence porosity used in the remainder of this handbook. Therefore, with $P = 0.5$, equation (9) becomes

$$Q_{des} = Q_{captured} = 8.5H^{2.2} \quad (10)$$

and

$$H = (Q_{des}/8.5)^{0.455}. \quad (11)$$

Similar to the berm, the protected area is the triangle on the left side of Figure 8. For $P = 0.5$, equipment, housing, etc., needs to be located $35H$ downwind of the fence to stay out of the regions where the snow will be deposited.

Table 6 shows the size of snow fence required for each snow transport class. In most cases, a single fence can be used, though the height of the fence increases with each size class. Increasing the height of the fence of

course increases the anchoring requirements; so it may be desirable to place multiple rows of fences, one upwind of the other in the same fashion as suggested for the snow berms, to provide the required protection. If this is the case, the spacing of the fences needs to be $40H$ apart to allow for the drifts that form between the fences.

Figure 8. Geometry of a snow fence and the drift that is deposited on the fence. The area protected by the fence is the triangular “protected area” behind the fence and the drift.

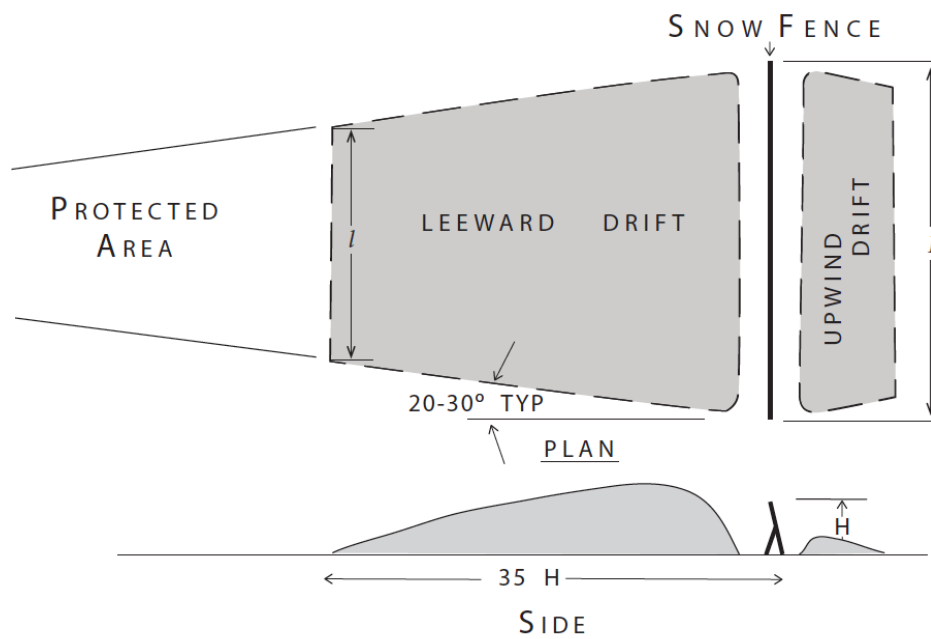

Table 6. The size fence required to handle various classes of snow transport severity (Tabler 1994). All values in this table are for a snow fence that is 50% porous ($P=0.5$).

Classification	Snow Transport (t/m)	Fence Height, H (m)	Fence Setback (m)
1: Very light	<10	1.1	39
2: Light	10–20	1.5	53
3: Light to moderate	20–40	2.0	70
4: Moderate	40–80	2.8	98
5: Moderately severe	80–160	3.8	130
6: Severe	160–320	5.2	180
7: Extreme	>320	>5.2	$35H$

For comparison, we can evaluate the volume of drift stored on a snow fence and berm of equal height by evaluating equations (8) and (11). For example, if the fence and berm were both 2 m tall, the fence would store 39 t/m while the berm can only store 4.2 t/m, approximately 1/9 as much.

The biggest disadvantage to snow-fence use for this application is the additional material that needs to be brought in to erect a fence. Either the fence can be constructed on-site or prefabricated and brought to the site. In this later case, the volume of a prefabricated fence is substantial; and transportation of the fence sections to the site may be a costly effort in its own right.

Another consideration in using snow fences is anchoring during use and storage between seasons. The anchors need to prevent the fences from overturning in the winds delivering the snow, yet the anchors need to be constructed so the fence can be released each season for storage. Preferably, the anchors could be reused every season, though this may be difficult depending on the type of anchor. Section 5 will discuss such fence design considerations.

3.1.3 Windbreaks

Snow protection shelters or windbreaks are used routinely to protect livestock in the winter (Jairell and Schmidt 1999). Rather than capture the snow upwind of the region to be protected, these V-shaped or semi-circular solid faced barriers deflect the wind and drifting snow and form a small protected region behind them as shown in Figure 9. For optimum performance, the width of the shelter, D , needs to be no greater than $15H$, where H is the shelter height. Properly sized, the shelter deflects the oncoming blown snow laterally and creates a protected region or sheltered area, shown in Figure 9, immediately downwind of the structure. In this sheltered region, the wind speed is reduced by 60%–80% and is relatively free of deposited drifting snow. When $D > 15H$, the shelter starts to behave more like a solid fence or berm, not all of the blowing snow is deflected laterally, and drifted snow starts to deposit inside the sheltered area.

Provided $D \leq 15 H$ snow does not deposit in the sheltered area, yet large wing drifts form on either side of the structure (Figure 9). As these build, one must access the sheltered area through the opening between the wing drifts behind the sheltered area. Consequently, equipment, buildings, tents, or another windbreak must not block the shelter access between these wing drifts.

The sketch of the drift in Figure 9 is for early stages of drift formation. As the season progresses, the upwind drift will grow taller and will start to encroach on the front of the structure and eventually will lay against the

structure. Eventually, the upwind drift will reach to the top of the shelter; and blowing snow will no longer be deflected but will blow over the top and deposit in the sheltered area. Unfortunately, the time and amount of snow transport that it takes to overwhelm the shelter has not been documented in the literature. Consequently, we anticipate that the drifts may need to be removed one or more times during a camp season to restore the effectiveness of the shelter. We suggest that if the upwind drift reaches half the height of the structure, it should be removed to reduce the possibility of overwhelming the structure during the next storm event.

Figure 9. Windbreak shelter used to protect livestock from blowing snow and wind. The windbreak can be either V shaped (shown) or semicircular but must be solid (no porosity) to work effectively to divert blowing snow. The red region indicates the approximate size of the sheltered area (after Jairell and Schmidt [1999]).

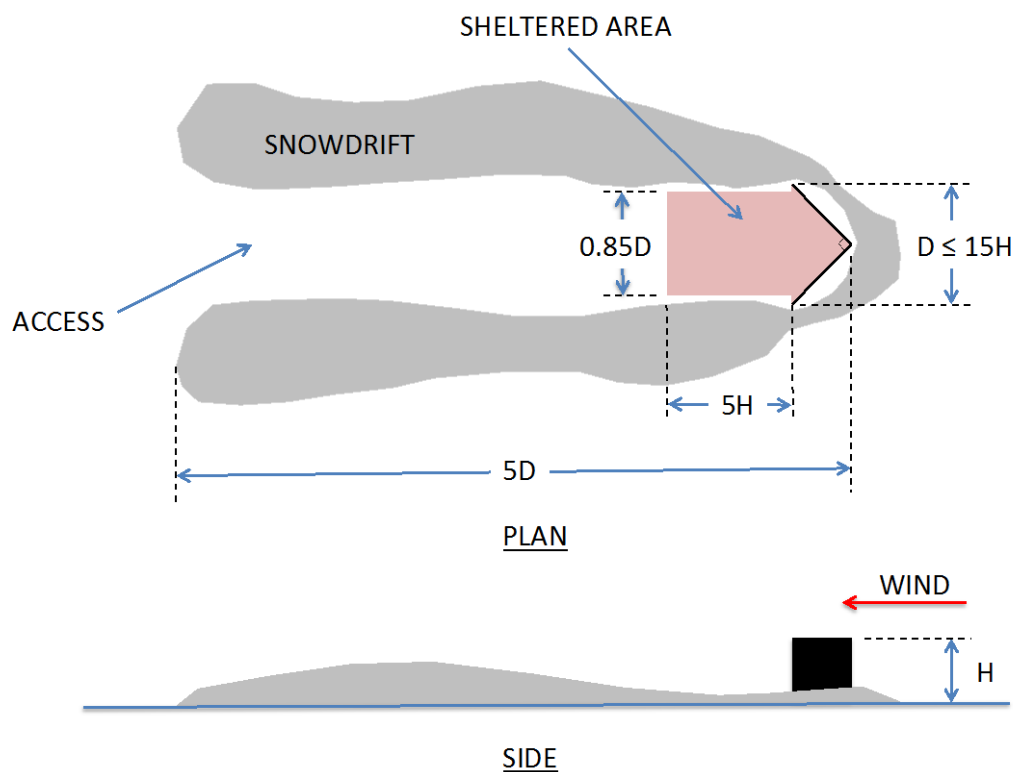

These windbreaks are commonly constructed by driving posts into the ground and securing either planks or wooden sheets (e.g., 4 × 8 ft plywood sheets, .75 in. thick [1.2 m × 2.4 m × 2 cm]) to the face. When using planking, one must take care to cover the windward face with plastic sheeting or tarpaulin to prevent wind and snow from going through the gaps between the planks.

Windbreaks could also be constructed out of snow, creating either V-shaped or semicircular berms. The advantage to this is that no materials need to be brought in, there are no concerns about anchoring the structures against the wind, and the berms are non-porous.

3.2 Sizing snow protection systems

3.2.1 Berms and snow fences

The length, L , of the berm or fence (Figures 7 and 8) is dependent on the desired protected area. The protected area is the triangular region downwind of the drift called out in Figures 7 and 8. These figures also show the base, l , of the triangular area: the protected length. We assume the protected length is a known quantity, determined by the requirements of the camp. By recognizing that the drift slants on the sides by as much as 30° as indicated in the Figures 7 and 8 and knowing the length of the drift that forms downwind of the berm or fence, we can calculate the minimum length L required to protect the length l .

As indicated in Figures 7 and 8, the downwind drift length for a berm and fence are $B = 6H$ and $35H$, respectively. Then

$$L = l + 2B \tan 30^\circ \quad (12)$$

or

$$L_{berm} = l + 6.9H \quad (13)$$

and

$$L_{fence} = l + 40.4H. \quad (14)$$

This shows that to protect the same area, a snow fence needs to be much longer than a berm.

The minimum protected triangular area is approximately an isosceles triangle (a triangle with each leg of equal length, l) with area, A , computed by

$$A = \frac{1}{4} l^2 \tan 60^\circ = 0.433 l^2. \quad (15)$$

If the area to be protected is known (i.e., determined by the requirements of the camp), the protected length can be determined from

$$l = \sqrt{2.31A}. \quad (16)$$

In Table 7, we provide calculated values of protected length and berm or snow-fence length for several representative protected area sizes and structure heights.

Table 7. Length of berms and snow fences required to provide a specified sheltered area (computed from equations [13], [14], and [16]).

Protected Area (m ²)	Protected Length (m) $\sqrt{2.31A}$	Structure Height (m)	Berm Length (m) $H+6.9H$	Snow Fence Length (m) $H+40.4H$
100	15	1.1	--	59
		1.5	--	76
		2	29	96
		3	36	136
		4	43	177
400	30	5.2	--	225
		1.1	--	64
		1.5	--	91
		2	44	111
		3	51	151
1000	48	4	58	192
		5.2	--	240
		1.1	--	82
		1.5	--	109
		2	62	129
5000	107	3	69	169
		4	76	210
		5.2	--	258
		1.1	--	141
		1.5	--	168
10,000	152	2	121	188
		3	128	228
		4	135	269
		5.2	--	317
		1.1	--	186
		1.5	--	213
		2	166	233
		3	173	273
		4	180	314
		5.2	--	362

3.2.2 Windbreaks

In Table 8, we show the protected area as a function of windbreak shelter height. To provide ample spacing between the downwind opening of the wind drifts and any other obstruction, we suggest the spacing between structures be no less than $7H$ as computed in Table 8.

Table 8. Sheltered area and geometry for V-shaped and semicircular windbreaks (after Jairell and Schmidt 1999).

Height, H (m)	Width, D (m)	Length of Wings*, L (m)	Sheltered Area† (m ²)	Downwind Spacing between Shelters and Obstructions, $7H$ (m)
2	28	20	434	14
3	42	30	976	21
4	57	40	1781	28

* Applicable for V-shaped shelters only

† Sheltered area = $\frac{1}{4}D^2 + 4.25DH$

Presently, there is no guidance provided as to the length of time or amount of snow transport until the shelter is overwhelmed. Therefore, we recommend that, if used, the shelters be monitored regularly. Once the upwind drift is at or above $\frac{1}{2}H$, we recommend clearing the upwind drift to restore the upwind topography to the original grade or to the grade of the surrounding terrain. Regular clearing of the wing drifts may be necessary, also.

3.3 Operational considerations

Though properly designed snowdrift protection systems can be very effective, they are not without maintenance. When such protection systems are applied in non-glaciated regions, the snow completely melts during the summer season, allowing the system to start anew every season. In Antarctica, this is not the case. Whatever drifts form by the end of the camp season will remain the following year if not addressed before breaking camp. If multiple berms are used for protection and left as is over the winter, it is likely that drifting will fill in between the berms, forming a massive drift up to the height of the berms the following summer. Similarly, with snow fences or windbreak structures, if they are left in place, they will become buried up to the top of the structure and will be irretrievable the following spring. If the fence is removed and the drift left, the drift will be largely intact the following spring.

Therefore, using drift protection in polar regions requires different management strategies than for applications in temperate zones. For a one-time camp, the drift can be left at the end of the season as it will not adversely affect camps in subsequent years. For camps that are re-established at the same location year after year, the snow protection structures (e.g., fences or windbreaks) will need to be removed to prevent them from being buried during the winter season. Depending on the camp, it may not be necessary to locate it at the exact same spot from year to year. If this is the case, the camp could migrate upwind annually so that it is upwind of the drifts formed by the prior year's protection system, leaving the drift to weather naturally into the surrounding terrain.

If it is necessary to site all or part of the camp in the exact same location in following years, one must consider the massive mounds of snow formed from drifting behind the berms, fences, or windbreaks and how they will affect future operations at the site. Some options are provided below.

To minimize impact on the camp for the following season, it is preferable that these mounds of snow be graded flat so that the terrain is flat for re-establishing the camp the following season. This may take considerable effort as the accumulated drift can be tall (4–5 m) and as the volume of snow can be substantial.

An alternate approach is to feather the snow mound into the surrounding terrain rather than remove it entirely. For example, it is not unreasonable to assume that the resulting snow mound on a berm has a roughly triangular cross-section 100 m wide \times 4 m tall with a base that is about 28 m. If this were graded flat, the amount of snow to move is approximately 5600 m³. As an alternative, this could be shaped into a tabletop with the edges of the snow mound tapered to merge it into the surrounding terrain. An acceptable slope from a drifting point of view is 1:7 or 14% grade as this would be aerodynamically smooth enough to prevent drifting to form on the tapered portions. From an operational point of view, a 6% or shallower grade may be more desirable as this would blend the mound into the surrounding terrain better.

To make this berm a level geometry feathered with the surrounding terrain, this would be a cut and fill operation with half of the snow volume cut off the top and used to fill valleys in the remaining mound or to feather the edges into the surrounding topography. The height where the area of the

cut volume is approximately equal to the remaining volume is 0.29 of the berm height (e.g., $0.29H = 1.2$ m for a 4m berm); using this approach, the amount of material that would need to be moved is roughly cut in half. The final dimensions of this flattened berm is about 100 m wide \times 1.2 m tall with the top of the trapezoid 30 m long and the base about 70 m long.

This rule of thumb applies to the drift geometry behind a snow fence as well, which is also roughly triangular. The volume that would need to be moved is about half the total snow volume, and the height of the resulting table top is about 0.29 the height of the drift behind the fence. So for a fence the height of the tabletop, $0.29 \times 1.2H = 0.35H$ with the understanding that

$$H = \text{fence height}$$
$$1.2H = \text{terminal drift height.}$$

If the mound is left in place and feathered into the surrounding terrain, one must consider where to establish the camp and snow protection system in following seasons. The following section (Section 4) will discuss this further.

4 Case Study: Pine Island Glacier Camp

To illustrate how to apply to an actual camp the steps outlined in the previous sections, we use the Pine Island Glacier (PIG) camp as a case study for developing a candidate snowdrift management design and to explore alternatives. The first step is to determine the period of operation. Based on the history of the camp, we learn that The PIG camp opens around 1 December and closes about 1 February. The next section addresses Steps 2–5.

4.1 Determining wind direction and snow transport

4.1.1 Using AWS data

The wind direction and amount of snow transported during the camp operational period can be estimated from the wind data measured at AWSs near the PIG site.

4.1.1.1 Step 2

AWSs were set up at three sites during 2008, 2009, and 2011. Table 9 shows the location and time that these stations were operational during the summer season (October–March). Figure 10a shows a typical monthly wind rose calculated from this data. Appendix B includes the entire set of wind roses.

Table 9. Location and period of operation of weather stations near the Pine Island Glacier site.

Year	Location	Period of operation
2008–2009	75° 11' S 101° 44' W	October 2008–March 2009
2009	75° 11' S 101° 43' W	October 2009
2011	75° 48' S 100° 16' W	January–February 2011

4.1.1.2 Step 3

If we assume that the fetch length is longer than 6 km (i.e., the fetch can be treated as infinite), then the transport can be computed using equations (1)–(3). Thus, the assumption is that there is always snow available to transport every time the wind blows. This gives a conservative upper limit to the possible transport in the absence of additional observations. An ex-

ample transport rose is shown in Figure 10b. Appendix C includes the entire set of transport roses.

Figure 10. Wind and transport roses for October 2008. North in these plots is true north. The wind rose indicates the percent time the wind is blowing in that direction. The transport rose indicates the percentage of total transport carried in that wind direction for that month.

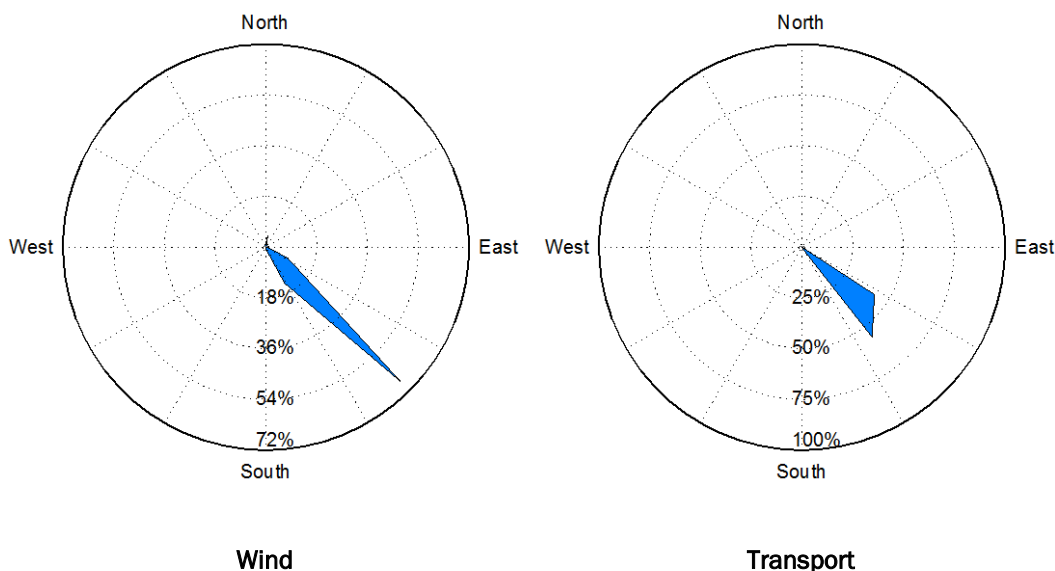

We note that each of these AWSs were not located at the same spot. The 2009 site was about 4 km east of the 2008–2009 station while the 2011 site was about 78 km south-southeast of the prior sites. Despite the wide separation between the earlier sites and the 2011 site, we used the data from that later site because it was in the general region and the prevailing katabatic winds come off the same land mass to the south of PIG; therefore, we assume that the computed transport is typical of the region. In Table 10 we provide a summary of the computed transport by month. The wind and transport data show that during the summer months, virtually all of the snow is transported from the SE direction (referenced from true North). Table 10 shows the mean transport based on the limited available data. This shows that most of the transport occurs early and late in the summer with much less drifting snow in November through January.

As stated previously, the PIG camp opens around 1 December and closes about 1 February. Based on the limited amount of data available (Table 10), during this period the estimated transport is on average 100 t/m and as much as 111 t/m (determined by summing the maximum values for December and January across the 3 years of data, Figure 11). This amount of snow transport is classified as “Moderately severe” (see Table 4).

Table 10. Transport by month near Pine Island Glacier site.

Month	2008	2009	2011	Average (kg/m)	Standard Deviation (%)
October	449,996	200,904	N/A	325,450	38
November	149,862	N/A	N/A	149,862	na
December	54,482	N/A	N/A	54,482	na
January	N/A	56,057	34,988	45,522	23
February	N/A	94,458	282,060	188,259	50
March	N/A	236,235	N/A	236,235	na

N/A = Data not available

na = Not applicable

Figure 11. Trend in drift transport at the Pine Island Glacier camp through the summer months based on data taken from 2008–2011. Bar height is average if applicable, and error bars indicate range in data.

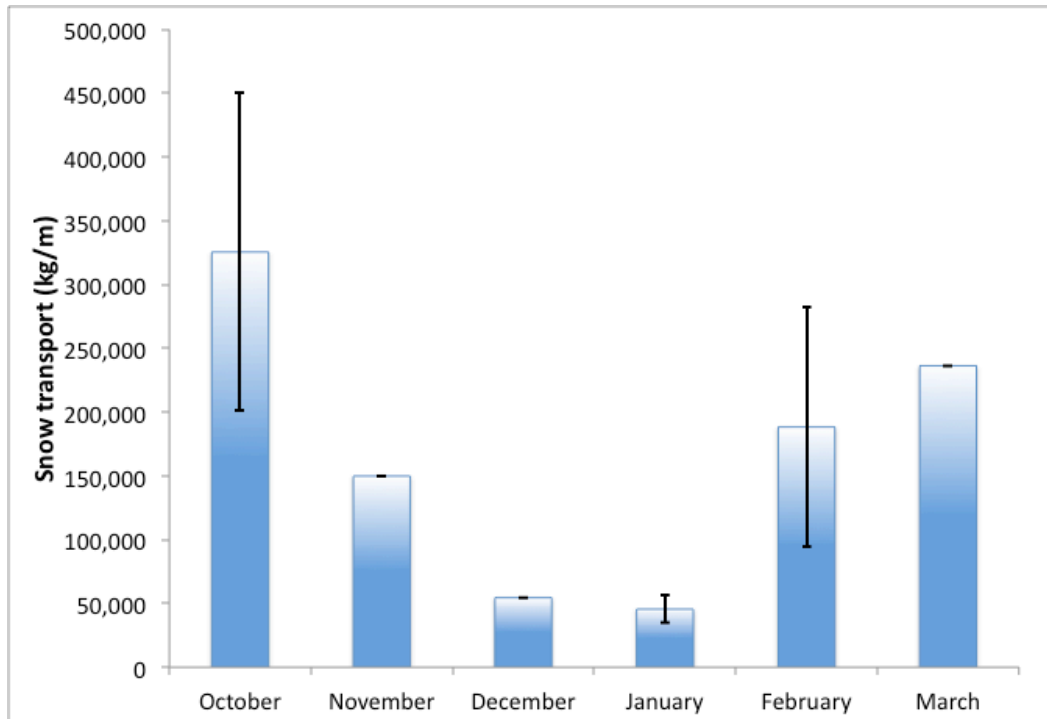

We note that with only one year of data for December and two years of data for January, it is difficult to do any statistical analysis to determine the probability of transport of this magnitude occurring during the operational season. If many seasons of data were available, it would be desirable to conduct a probability analysis and to determine a design transport associated with it and an acceptable risk level. We cannot do that with this data, and we make our best estimate of transport using the average transport from this limited data.

Though this is the estimated total amount of snow picked up by the wind, some is lost due to sublimation during transport. By applying equation (3) to the above estimate of snow transport, the deposited transport over the camp season is $\bar{Q}_{dep} = 70 \pm 7.7$ t/m; this will be used to determine the design value for the seasonal transport at the PIG camp.

4.1.1.3 Step 4

To determine a design value, a design modulus, K , needs to be applied. The value chosen is dependent on the level of acceptable risk of overwhelming the drift protection system employed, which needs to be determined at the design stage for a particular camp, and on the possible impact to personnel if the system is overwhelmed. Such a risk-based analysis of the camp is not addressed in this handbook but should be considered for the actual camp design. For the purposes of demonstration in this case study, we use a PE of 5%, which gives $K \approx 1.49$ (Table 5). Based on this, a design operational season transport would be $Q_{des, season} = 70 \times 1.49 = 104$ t/m.

4.1.1.4 Step 5

Referring to Table 4, we see that a design transport of 104 t/m, even though this is a relatively small amount of transport for this location, is considered “Moderately severe” (class 5) by most standards.

4.1.2 Alternate method to determine wind direction and severity class

For comparison, below we estimated the wind direction and transport if we lacked the wind data presented above.

4.1.2.1 Step 2 Alternate

As discussed above, in the absence of meteorological records, the wind direction can be determined from assumptions about katabatic (downslope) winds and orientation of snowdrift features on the landscape.

Estimating the wind direction based on the slope orientation can be tricky in this region. If we assume the dominate downslope is from the center of the continent, then the wind direction would be approximately a bearing of 180° based on the location of the PIG camp with respect to the central portion of the continent. However, the Ellsworth Mountains to the SE of PIG may also have an influence on the wind direction. Katabatic winds

driven by that feature would have a bearing closer to 135° . Based on this quick assessment, we would have to conclude that the winds could be from 135° – 180° .

Satellite imagery of the camp, as provided in Appendix D, helps to improve this estimate considerably. Visible in the image are snowdrifts behind man made features and elsewhere in the region. The drifts fan somewhat, indicating the variability in the winds. Yet, the general orientation is from the upper right to lower middle of the graphic. This image also shows the bearing of true north (lower left). Based on the orientation of the drifts with respect to true north, it appears that the drift orientation, and therefore wind direction, has a bearing of approximately 135° , consistent with the wind rose in Figure 10.

4.1.2.2 Step 3–5 Alternate

Having obtained an estimate of wind direction, we now follow the method associated with equation (5) to estimate the snow transport at this location. We assume an infinite fetch ($F \geq 6000$ m) and use the figures provided in Appendix A to get an estimate of S_{we} . In Figure 12, we have plotted the location of the three AWSs on the Antarctic continent to help orient the approximate location of the PIG camp to the accumulation data presented in Appendix A. Comparing this to Figures A1–A3, we find that the annual P–E accumulation for this general region is 400–500 mm/year. This total needs to be adjusted for the period of operation of the camp (December–January).

From Figure 5, we find that the PIG camp is in sector E. We also note that it is a low elevation location near the coast, so “Entire continent” in Table 1 may be another way to classify this site. For comparison, we will compute the transport for both of these classifying regions. The percent of the total transport associated with December and January for sector E is 5.16 (December) + 6.10 (January) = 11.26% . Similarly, we find the average for the entire continent is 10.24% . Thus, for each “region,” the approximate S_{we} during the time of camp operation is $S_{we} = (0.4\text{--}0.5 \text{ m/year})0.1126 = 0.045\text{--}0.056$ m (Sector E) and $0.041\text{--}0.051$ m (entire continent). We use the range in results provided in the calculation of S_{we} in equation (5) to get a range of $Q = 123\text{--}168$ t/m (Table 4). By applying the foregoing outlined procedures, we arrive at a design value of $Q_{des, season} = 128\text{--}175$ t/m; this indicates the drifting problem is “Moderately severe” to “Severe.” This result is the same order of magnitude as what we found from the wind rec-

ord (application of equations [1] and [3]), though 20%–70% higher, and demonstrates that both methods agree favorably. We cannot say that one method will be consistently higher than the other though we expect that, for temporally long climatic records of wind and P–E accumulation, we should see a convergence in the estimated transport for the two methods.

Figure 12. Antarctic continent showing the location (yellow push pins) of the Pine Island Glacier met stations for 2008–2011.



4.1.3 Storm-scale snow transport

For comparison, in addition to an estimate of the transport for the operational season, it may also be desirable to estimate the “storm” transport, or the snow transported in one storm. There are two reasons for this:

1. This is likely the amount of transported snow that will need to be managed after every storm in the camp if no snow control measures are employed, so this provides a baseline case
2. The transport over the operational season may exceed what can be readily mitigated with available resources. However, available resources may be sufficient to handle the snow deposited in increments associated with each storm even though the resources may need to be employed on a nearly continuous basis to keep up.

Estimating the storm-scale transport is done in similar fashion to what was outlined in Section 4.1.1 with the period for summing up the transport being the length of an individual storm, rather than a month. This is done as follows. First, because of the dominant wind direction during the summer months, we need not consider the effect of wind direction on the transport calculations and need only to consider the wind speed and to apply equations (1)–(3). Figure 13 shows the storm transport for a typical month at PIG. In this figure, one can see several transport events. Equation (2) can be used to compute the total transport for each event and equation (3) estimates the deposited snow (still assuming infinite fetch length).

Figure 13. Time series of snowdrift transport during December 2008 based on wind data measured at the PIG AWS.

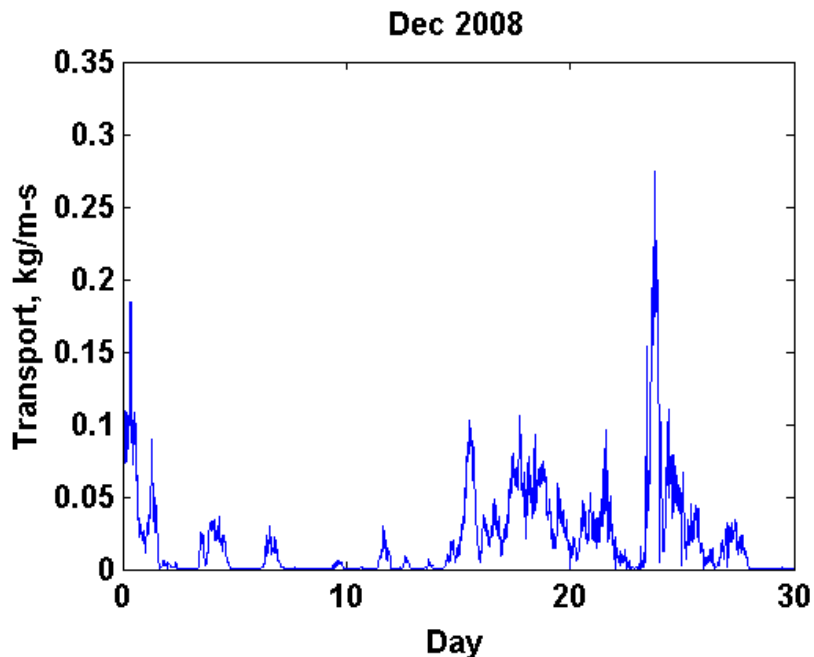

This analysis was performed for all of the events for which there was recorded wind data in December and January and is summarized in Table 11.

From the limited storm data summarized in Table 11 (15 events), a probability plot can be created as shown in Figure 14 to determine the transport magnitude from a storm associated with an acceptable risk level. From Figure 14, the percent chance of occurrence (PC) of a storm is determined for each storm event. Using this, a design storm transport can be determined based on a PE of 5% ($PC = 100 - PE$); and the design storm transport determined from Figure 15 would be about 25 t/m (25,000 kg/m). This is a severity classification of “Light to moderate.” Here we have used $PE = 5\%$ to be consistent with what was used in Section 4.1.1 to determine the design annual transport.

Table 11. Summary of storm data from December 2008 and January 2009 and 2011.

Event	Start	End	Duration (days)	$Q(\text{kg/m})$	$Q_{dep}(\text{kg/m})$
December 2008					
1	4 Dec.	5 Dec.	1.32	2183	1528
2	7 Dec.	8 Dec.	0.73	780	546
3	12 Dec.	13 Dec.	0.52	550	385
4	16 Dec.	23 Dec.	7.68	24440	17108
5	24 Dec.	28 Dec.	4.78	16610	11627
January 2009					
1	2 Jan.	7 Jan.	5.40	29344	20541
2	9 Jan.	11 Jan.	1.63	5300	3710
3	14 Jan.	17 Jan.	3.37	9150	6405
4	19 Jan.	21 Jan.	2.26	3300	3210
5	22 Jan.	23 Jan.	0.64	720	504
6	23 Jan.	25 Jan.	1.75	1510	1057
7	26 Jan.	30 Jan.	3.05	4990	3493
January 2011					
1	1 Jan.	14 Jan.	13.2	19546	13682
2	15 Jan.	21 Jan.	6.07	2770	1939
3	22 Jan.	25 Jan.	2.66	11180	7826

Figure 14. Cumulative probability distribution plot of the deposited transport associated with the storms tabulated in Table 11 (n=15).

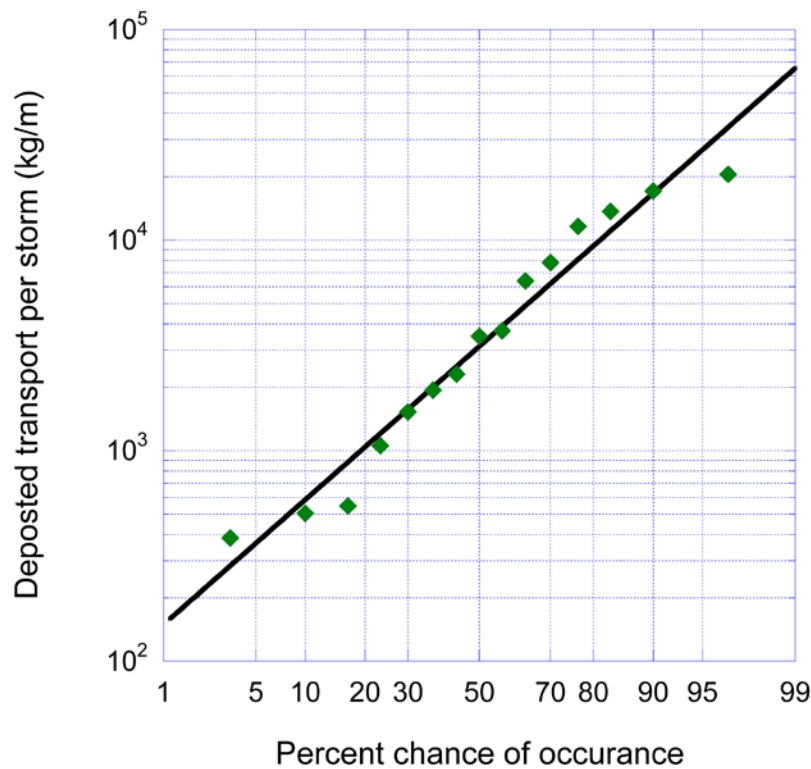

4.2 Determining the camp footprint (Step 6)

Based on site data contained in “Pine Island Glacier Field Facility: Winter Cargo 2012” Chart (Appendix D), the approximate protected length for the cluster of camp buildings in the lower right—allowing also some protection for the tent city that provides berthing but that is not visible in the image—is $l = 150$ m. From equation (15) we determine the protected area is

$$A = 0.433l^2 = 0.433(150 \text{ m})^2 = 9750 \text{ m}^2.$$

This is an equal sided triangular area. We note the layout of the buildings is linear in Appendix D. Clustering some of the buildings or the tent city in a triangular region bounding the protected area may more efficiently use the protected area. This would reduce the protected length and thereby reduce the length needed for the protection structures. We will further consider this option as we discuss and refine the design below.

4.3 Designing drift protection measures (Step 7)

From the foregoing, we found an operational season design snow transport of 104 t/m (“Moderately severe”) and a design storm transport of 25 t/m (“Light to moderate”). These values will be used as the basis for sizing the snow protection system. For this design, we assume another design requirement is that the camp will need to be re-established in the same location every year, requiring “cleanup” of the drifts and berms at the end of the season as discussed in Section 3.3.

The procedure to do this is as follows:

1. Determine the size and number of snow protection structures needed based on the severity class determined. For the berms, this can be found in Table 5. For snow fences, use Table 6. These tables also provide the set-back from the camp and the spacing between protective structures.
2. Based on the width of the protected region (Steps 6) we can determine the length of the protective structure from equations (13) (berm) or (14) (snow fence).

We will first consider the design of a berm system and then a snow fence. We also present a possible design for using windbreaks as snow shelters though we cannot say how much of the season they would function, what level of maintenance would be required (i.e., snow removal), or if the windbreaks would be overwhelmed in a single storm event.

4.3.1 Berm

4.3.1.1 Season-long protection

Using Table 5, we find that a “Moderately severe” classification requires 8 berms that are 4 m tall to protect the site. This would handle all of the snow transported during the operational season at the PIG camp. The spacing between berms would need to be 28 m apart.

The protected area is a triangle as depicted in Figure 15. Applying equation (13) for a 4 m tall berm, the length of the berm should be

$$L_{berm} = (150 + 6.9 \times 4)m \approx 180m$$

and be set back from the camp by 28 m.

Figure 15. Sketch of a berm configuration to protect the Pine Island Glacier camp from drifting snow.

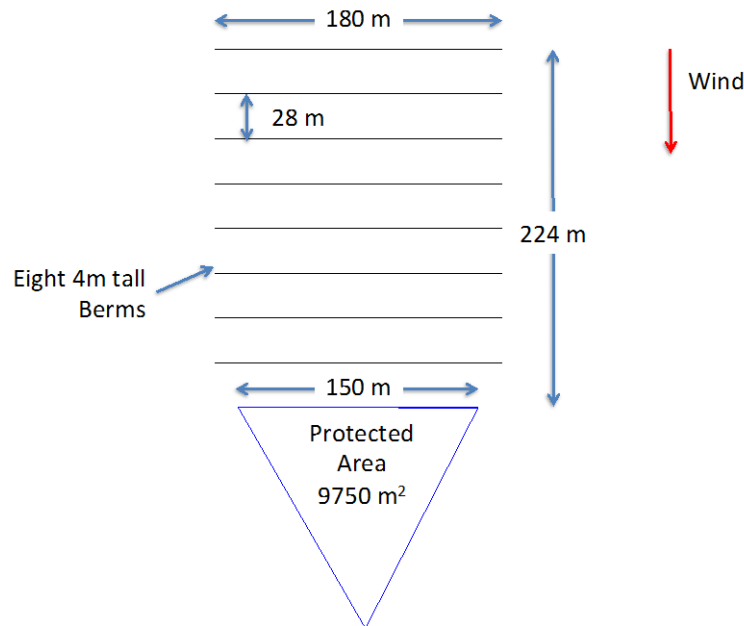

The volume of snow that would be needed to create these 8 berms is determined using Table 5 as follows. The cross-sectional area of the 4 m tall berm is 20 m² (Table 5). So the volume of each berm is approximately

$$20 \text{ m}^2 \times 180 \text{ m} = 3600 \text{ m}^3.$$

Then, the total volume of snow needed to create all of the berms is

$$V_{berms} = 3600 \text{ m}^3 \times 8 = 28,800 \text{ m}^3.$$

The amount of snow that would need to be removed by the end of the season (EOS) is estimated to be the volume of the berms plus the volume of the deposited snow or

$$V_{EOS} = QL/\rho_s + V_{berms} = 104 \text{ t/m}(180 \text{ m})1000 \text{ kg/t} \div 350 \text{ kg/m}^3 + 28,800 \text{ m}^3,$$

$$V_{EOS} = 82,300 \text{ m}^3.$$

Table 12 summarizes the information for this design for comparison with other options considered here.

Table 12. Summary of design information for snow drift protection using berms or a snow fence. The protected length and area for all of these designs is 150 m and 9750 m², respectively.

	Full-Season Protection (Berm)	Storm-Scale Protection (Berm)	Full-Season Protection (Snow Fence)	Storm-Scale Protection (Snow Fence)
Design snow transport (t/m)	104	25	104	25
Severity class	Moderately severe	Light to moderate	Moderately severe	Light to moderate
Number of structures in system	8 berms	4 berms	1 fence	1 fence
Structure height (m)	4	3	3.8	2
Structure length (m)	180	170	300	230
Structure spacing or set back (m)	28	21	130	70
Volume of snow needed to create structure (m ³)	28,800	8160	0	0
Max volume of snow to be removed after every storm (m ³)	0	12,100	0	16,400
Volume of snow to be removed at end of season (m ³)	82,300	20,300	89,100	0
Total snow volume moved all season (m ³)	111,100	58,700	89,100	68,300

4.3.1.2 Storm-duration protection

Using the same approach, we determine the design for a system for handling drifting snow on the time scale of storm frequency. With such a design, the snow drifts that form after every storm would need to be removed to provide a place to trap snow during the next storm. From Table 5, we find that two possible berm heights are acceptable for “Light to moderate” classification; we compute design information for both and find that 3% less snow needs to be handled (between creating the berm and managing the trappings) for the case of four 3 m tall berms. Table 12 summarizes this scenario.

The difference between this approach and the prior design (season-long protection) is that the berms will need to be cleared of snow after every storm event. The total season-long effort for snow removal depends on the number of storms and the magnitude of them. However, since the season-long design transport is the same for all of these cases (104 t/m), the total amount of drifted snow that needs to be managed will be the same for a season-long vs. storm-scale design. The advantage of the storm-scale design is that there is a savings in effort by constructing fewer berms at the beginning of the season (2 or 4 vs. 8). This is reflected in the last row of Table 12 where the amount of snow moved (in the form of building or tearing down berms or clearing drifts) is cut in half by employing a storm-scale solution rather than a design that traps a full season of drifting snow.

4.3.2 Snow fence

4.3.2.1 Season-long protection

The protected length and area does not change for a snow fence in comparison to a berm, so we can use the values determined in Section 4.2 for the snow fence design, $l = 150$ m. Designing for season-long protection and referring to Table 6, we find that for a “Moderately severe” classification, the recommended fence height is 3.8 m; the setback from the protected area is 130 m, and only a single fence is needed.

Applying equation (14), we find the length of fence needed is

$$L_{fence} = 150 \text{ m} + 40.4 (3.8 \text{ m}) = 300 \text{ m}.$$

The volume of snow captured behind the fence at the end of the season is approximately

$$V_{drift} = 104 \text{ t/m} (300 \text{ m}) 1000 \text{ kg/t} \div 350 \text{ kg/m}^3 = 89,100 \text{ m}^3.$$

Table 12 provides the design information for a snow fence of this size.

For comparison, we consider the possibility of providing this same protection with smaller fences (e.g., using standard 4 ft [1.2 m] wide snow fence material). In this example, we will use $H = 1.5$ m (this height allows for a 10%–12% bottom gap as recommended in standard snow fence installations; see Section 5). The setback and spacing between fences for this size fence is 53 m. For season-long protection, five such fences in series need to

be used (104 t/m ÷ 20 t/m capacity per fence). The length of each fence section is

$$L_{fence} = 150 \text{ m} + 40.4(1.5 \text{ m}) = 210 \text{ m}.$$

The snowdrift volume captured per fence is approximately

$$V_{drift} = 20 \text{ t/m} (210 \text{ m}) 1000 \text{ kg/t} \div 350 \text{ kg/m}^3 = 12,000 \text{ m}^3.$$

The total drift volume by the end of the season is about five times this or 60,000 m³, about 30% less than for a single fence owing to the shorter individual fence length. Of course, the total deployed length of fence in this case would be 1050 m or about three times as much as for a single 3.8 m tall fence.

For camps, such a design may be preferred over a single 3.8 m tall fence since the taller fence requires a more robust anchoring system and more effort for installation and removal at the beginning and end of the operational season. Therefore the shorter fence may be easier to implement with available personnel and resources.

4.3.2.2 Storm-duration protection

As with the case for the berm design, we can consider sizing a fence system that protects against a storm-scale event, understanding that after every storm it would be necessary to remove the snow drifts that had formed to allow capacity to trap snow during the next storm. Table 6 and equation (14) can help to quickly determine the design of such a system. The height of a fence for a “Light to moderate” severity is 2 m; the set back is 70 m. The fence length determined from equation (14) is 230 m. The approximate drift volume that will need to be managed and removed during the season is

$$V_{drift} = 104 \text{ t/m} (230 \text{ m}) 1000 \text{ kg/t} \div 350 \text{ kg/m}^3 = 68,300 \text{ m}^3$$

or 23% less snow drift volume than for the season-long protection design summarized in Table 12.

4.3.3 Windbreak

The foregoing outlines methods that protect the entire camp with a single structure. The protected area of a windbreak is considerably smaller than straight berms or a snow fence can provide. A windbreak can protect smaller “communities” of buildings or tents, but several windbreaks will be needed to meet the needs of the entire camp. Also, while we previously used the current configuration of the camp that is laid out roughly in a straight line that is about 150 m, the windbreak is more suited to protecting an area rather than a linear feature. So, one would need to determine the area that needs to be protected; and protection of this entire area would need to be handled by setting up several small communities, each protected by a shelter. Let us assume that when grouped into these smaller communities, the total area to protect is equal to the protected area used for the berms and fence designs discussed above: 9750 m² (Section 4.2). Layout of the windbreak communities should allow adequate access space between buildings, tents, and equipment.

Based on an area of 9750 m² and the data in Table 8, we find that for a 3 m and 4 m tall windbreak, 10 and 6 separate windbreaks are required, respectively. Using snow berms formed into a V or semicircle to create the windbreaks, we could estimate the volume of snow needed to construct the windbreaks. Table 13 summarizes this information.

Table 13. Number of windbreaks needed to protect 9750 m².

Windbreak Height (m)	Number Needed	Snow Volume (m ³)	
		V shaped	Semicircular
3	10	7200	7900
4	6	9600	10,700

Clearly, using the 3 m tall V-shaped windbreak minimizes the total volume of snow that needs handling even though more windbreaks are necessary. Furthermore, the volume of snow needed is 12% less than what is needed to construct the berms for storm-scale protection Table 12. Figure 16 demonstrates such an arrangement. It is interesting to note that the length of the camp gets stretched out to a much larger area with this design. This is almost five times longer than the protected length for the berm and fence designs.

Figure 16. Layout of 3 m tall windbreaks to protect the camp structures.

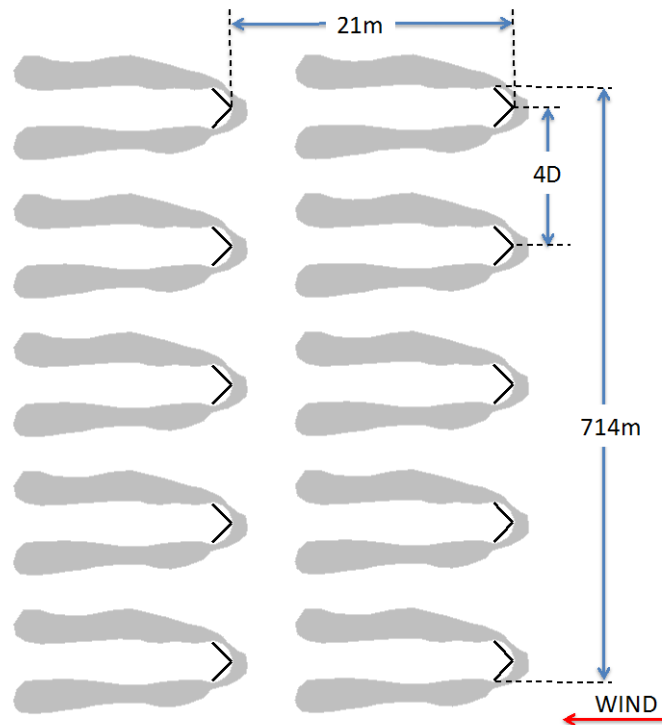

What is not clear at this point is the total volume of snow that needs to be managed with windbreaks (berm construction plus drift management) or how often the snow management will need to take place (after every storm, several times per season, or only at camp close). Having no documented information on drift volume as a function of snow transport limits our ability to fully assess the level of effort needed to maintain these structures over the full operational season. At this point, we do not recommend an entire camp be designed around this concept initially, rather an experimental community could be set up to evaluate windbreak effectiveness at a particular camp; and if it shows promise, the concept could be applied more widely. During such an evaluation, we recommend tracking the amount of snow transported and that accumulates around the structures over time and the frequency that the drifts (upwind and wing) need to be cleared to preserve functionality and safety.

4.4 Comparing protection methods and addressing considerations for application (Step 8)

The amount of snow that needs to be moved either at camp setup or at the end of the season to implement any of these protective measures is similar

in magnitude. Table 12 shows that the storm-scale designs of the berm or snow fence require moving the least amount of snow (approximately 60,000 m³). The amount that needs to be moved for the berm full-season-protection design is about twice that of the storm-scale design while the snow-fence full-season-protection design requires 20%–30% more snow moved than for the storm-scale design. For windbreaks, we do not know enough about their performance to say how much snow will need to be managed over an entire season or how frequently these maintenance operations will need to occur.

For comparison, we estimate the amount of snow that may need to be managed in the baseline case or what is currently done at PIG to try to mitigate the snow drifting. Presently, a snow berm is constructed just upwind of the main building compound. The approximate length of this berm is about 100 m; it is 3–4 m tall. From Table 5, we see that a 4 m tall berm has a cross section of 20 m²; therefore, construction of the berm requires about 2000 m³ of snow.

This single berm would not be able to capture all of the snow transported in a season or even in a storm. Its capacity (Table 5) is about half that of the transport associated with a design storm: 25 m/t. Therefore, the berm will become completely saturated on a regular basis, and any remaining snow will deposit on and around the buildings that the berm was placed to protect. Deposition of snow on and around buildings can block vents and entrances, creating safety issues.

The amount of snow deposited on the berm and in and around the buildings will need to be removed after every storm. It is not clear how much snow volume this will total up to as the amount of snow captured on the buildings after the berm is saturated depends on building geometry, making it hard to determine. However, it is unlikely that the buildings will capture all of the snow that gets by the berm.

For this baseline case, the minimum amount of snow to manage would be the seasonal deposition of snow on the berm (assuming the berm is cleared of drifts after every storm). This is approximately 18,000 m³ (4300 m³ is the maximum volume of snow captured by the berm, and there is on average 104 t/m of snow deposited annually, or about 4.2 design storms annually: $4.2 \times 4300 \text{ m}^3 = 18,000 \text{ m}^3$). The actual volume that will need to annually be moved off the berm and from around the build-

ings will be larger than 18,000 m³, but we presume less than the amount of snow moved in the storm scale design presented in Table 12. So our best estimate for season-long management of snow for the baseline case is somewhere between 22,000 m³ (berm construction, snow removal after every storm, and berm demolition at the end of the season) and 58,000 m³ (storm-scale berm design, Table 12).

This fails to consider the additional work associated with hand shoveling the buildings out after every storm as equipment can only clear so much of the snow. Furthermore, entrances and vents will likely be blocked during portions of the storm, potentially posing a safety hazard, if personnel do not clear these regularly during the storm. Therefore, current practice has the potential to reduce to some degree the amount of snow that needs to be managed; however, more snow will likely need to be moved by hand and possibly during a storm to prevent unsafe living and working conditions. Obviously, a balance needs to be struck between minimizing the amount of snow that needs to be managed in camp and maintaining safe operations.

Because the amount of snow to manage translates to additional manpower and equipment time, any reduction in snow volume reduces the cost of the snow protection method. With this in mind, we explore ways to further reduce the volume of snow to manage.

The forgoing used the existing camp layout, and from that we determined the protected length, including the fixed buildings (galley, generator, gantry, etc.) and tent city. The current layout spreads these along a straight line approximately 150 m long. With this protected length, the protected area is 9750 m² (Section 4.2), most of which is unused due to the lineal layout of the camp.

For illustrative purposes, let us assume that the footprint of the camp (allowing for egress around buildings and tents, could fit in half the protected area given above (i.e., 4875 m²). Applying equation (16), the protected length is now about 100 m, which means the camp fits into a triangle that is 100 m on a side.

If we apply this to the fence design that provides storm-scale protection, as described in Section 4.3.2.2, the new fence length would be reduced from

230 m to 180 m; and the captured volume over the course of the season would be reduced from 68,300 m³ to 53,500 m³, a 20% reduction.

We can apply this approach to all of the designs summarized in Table 12 to provide an “optimized camp configuration” for the snowdrift protection design. Table 14 summarizes these volumes. Of course, this is not a truly optimized configuration as the assumption that the camp can fit in a triangular area that is 4875 m² needs to be verified. We make this assumption merely to demonstrate the value of designing based on protected area vs. protected length.

Table 14. Estimated snow volumes that need to be moved and the level of effort to handle snow associated with drift control measures for an “optimized” camp layout. Times are based on 9-hour work days with a single operator and piece of equipment, and the Tucker can move on average 20 m³ of snow per hour while the Caterpillar bulldozers (D6, D7, or D8) can move on average about 70 m³ per hour.

	Berm: Full Season	Berm: Storm Scale	Fence: Full Season	Fence: Storm Scale	3 m Windbreak
Optimized camp snow volumes (m ³)	78,600	47,500	75,300	53,500	n/a
A. Time to construct berms					
Tucker	110 days	32 days	0	0	40 days
Caterpillar	32 days	9 days	0	0	11 days
B. Time to handle all snow (construction and removal)					
Tucker	1.2 years	0.7 years	1.1 years	0.8 year	n/a
Caterpillar	125 days	75 days	120 days	85 days	n/a
C. Time to handle all snow if the mound is feathered into the surrounding terrain (construction and removal)					
Tucker	0.6 years	0.6 years	0.6 years	0.7 year	n/a
Caterpillar	63 days	63 days	60 days	75 days	n/a

Red = Longer than the operational season of the camp (90days).

Yellow = Operational length of camp ≥ Time to move snow ≥ 50% operational length of camp

Green = Less than 50% of the operational length of the camp.

n/a = Not enough information to determine this quantity.

To provide an idea of the level of effort required to implement any of these approaches, we consider the amount of snow that can be moved by typical equipment. For example, the estimated capacity of the Tucker available at PIG camp is 20 m³/hr*. This is a rough estimate assuming the Tucker would move the snow only the distance necessary to flatten the drift and to feather it out into the surrounding terrain. If the snow needed to be moved

* Estimate of Tucker performance provided via email from Dean Einerson, Camp-Manger at Pine Island Glacier, Antarctic Support Contractor, 4 October 2012.

further distances, this production rate would drop significantly. For comparison, we obtained information on snow removal performance for large bulldozers (e.g., Caterpillar D6, D7, and D8) at South Pole Station*. The average snow handling capability for equipment this size is about 70 m³/hr, about 3.5 times greater than the Tucker.

Table 14 attempts to put the snow handling capability in context with the estimated quantity of snow that needs to be moved, with entries coded red indicating the time to handle the snow is longer than the time the camp is operated in a single season.

When presented this way, it is clear that for all of these snow control methods, if the camp needs to be re-established at the same location every year necessitating removal of all or part of the drift and berms (efforts associated with B or C in Table 14), the amount of snow that needs to be handled is far greater than a small piece of equipment (e.g., Tucker) can handle on its own and that larger equipment and multiple operators or pieces of equipment are needed to handle these large volumes. Even with a single bulldozer working one shift, it would spend almost all season moving snow (60–90 days) assuming the operational duration of the camp is about 90 days (including camp setup and strike).

We note that Table 14 focuses on the amount of equipment time associated with moving or managing snow. It does not include the effort required to transport snow fences or fence construction materials to the camp nor time to erect or to remove a snow fence. These considerations would need to be addressed separately as they depend on fence design and camp location. For example, at some camps, the materials can be brought in by traverse, while for other camps, the only practical method of transportation is by aircraft. Though time associated with this is not zero, it typically is on the order of a few days to a couple of weeks. Section 5 covers issues regarding the level of effort required for snow-fence installation and removal.

The most promising of these methods (coded yellow in Table 14) appears to be storm-scale designs, provided a large piece of equipment like a D6 Caterpillar bulldozer is made available to manage the volume of snow at

* Estimate of Caterpillar bulldozer performance from records of snow removal operations at South Pole Station, 2009–2012, provided via email from Martin Lewis, South Pole Operations Manager, Antarctic Support Contractor, 5 October 2012.

the camp. The methods coded red we assume would not be viable options as the level of effort is larger than available resources can meet.

We note that we cannot at this time do a similar type of analysis for the windbreak design as we have no information on drift volumes. However, looking at the spatial extent covered by a camp layout employing this design (e.g., Figure 16), we assume that the level of drift management will be similar in magnitude to the storm-scale solutions presented in Table 14 if not larger. Further research is required to say more about this snow protection method.

As discussed in Section 3, we can further reduce the snow handling requirements if we consider flattening and tapering the mounds of snow at the end of the season rather than pushing the snow out to return the topography to essentially the level grade prior to season start. We now look at the ramifications of such an approach. As an example, we consider the effects of this strategy on the berm storm-scale design presented in Table 12. Figure 17 is a sketch of the geometry at the end of the season.

Figure 17. Approximate geometry of drifts formed on the storm-scale design by the end of the season. The red profile in the elevation view indicates the approximate geometry of the snow mound after it has been graded and feathered into the surrounding terrain. Drifts and graded snow mound are drawn to scale.

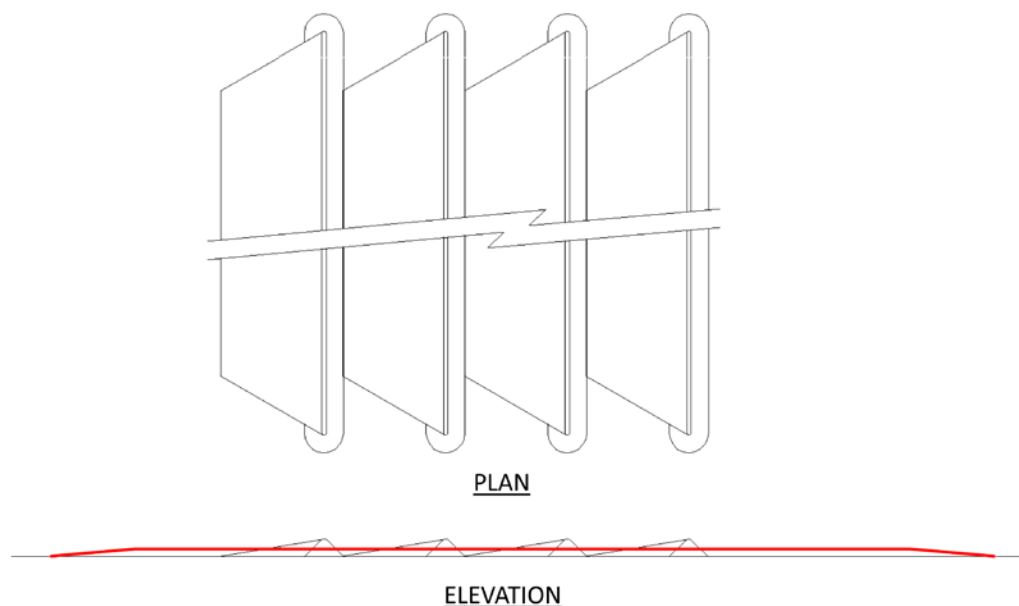

By applying this method, it approximately cuts the volume of snow that needs to be moved at the end of the season in half. For storm-scale de-

signs, this does not have as large of an effect as for full season designs as a large fraction of the transported snow has already been moved by the close of the season to keep the structures clean for the following storm. We see from Table 14, option C, that applying this approach cuts the snow management time for all of the approaches to the point where they are feasible (yellow) within the operational season even though the equipment would need to be operated almost continuously between storms for the entire season.

The effect of partial snow-mound removal (feathering the mound into the surrounding terrain) on camp operations during subsequent seasons may be as follows. The feathered mound (red line shown in Figure 17) raises the elevation of the snow a modest amount above the surrounding terrain; in the case of a 4 m tall berm, the elevation of the flattened mound is about 1.2 m. It is possible that berm or snow-fence structures could be re-established in approximately the same location the following season; and with feathering of the mound into the surrounding terrain, there would be minor impact on the camp for the following season. However, after successive seasons, the end-of-season mound would get taller and taller. Therefore, it may be advisable to move the entire camp either laterally or upwind so that the camp is on top of the mound and the snow protection system is moved to a region that is at a lower initial elevation than the camp. Placing the camp on this higher elevation may allow it to be located at the same place for two or more seasons before the end-of-season mound is higher than the camp grade elevation.

As a final consideration, if the camp did not need to be established at the same location every year (i.e., the camp could migrate upwind or laterally to avoid the drift deposition from prior years), the effort associated with “cleanup” would be eliminated. Only the time to construct and to maintain the protection system would need to be considered (i.e., A in Table 14). For full-season designs, the construction time—and removal time for snow fences—would be about the only effort required, making these options much more feasible in the context of available resources to implement the designs. Storm-scale designs and snow shelters would still require maintenance after every storm.

Section 4 illustrates the following:

1. Adequate snowdrift protection can be provided with either a berm or a snow-fence design. However, the level of effort to provide this protection is substantial and, depending on camp siting from year-to-year, may be beyond the resources currently assigned to the Pine Island Glacier camp.
2. With a reconfiguration of the camp to optimize its layout (i.e., minimizing the protected area) and with the efficient use of equipment to minimize snow removal and relocation, snow drift protection systems could be effective provided greater snow moving capability is made available at the camp.
3. The use of windbreaks may provide an alternate means of snowdrift protection. However, information on the performance of these systems is insufficient to design a full-season or storm-scale solution. Consequently, we recommend using this method on an experimental basis wherein the snow accumulation is closely monitored to avoid overwhelming the structure during a single storm.
4. If the camp is limited to the currently available snow moving resources, a smaller scale snow protection system can be designed to address drift problems on critical camp resources. For less critical functions or functions that historically are not greatly impacted by snow drifting, current snow-drift management methods may be satisfactory.

Final decision of whether to provide protection using any of these methods may depend on other factors, such as the feasibility of properly anchoring a tall snow fence or the availability of snow-moving equipment and operators during camp opening, closing, etc. Weighing such considerations is beyond the scope of this handbook, as input from camp personnel is needed to properly put all of the options in proper context. However, the methodology outlined in Section 3 and demonstrated in this section shows how to create a drift management design and how to explore strategies for camp layouts.

In the next section, we provide more detail regarding snow-fence design applied to Antarctic applications.

5 Snow-fence Design for Antarctic Application

As discussed in Section 3.3, most applications of snow fences are for regions where the snow melts away seasonally. In glaciated regions, this does not happen and requires altering standard snow-fence design and implementation. Furthermore, the fences will most likely not be anchored in soil but rather in compacted snow or ice; therefore, we also discuss considerations for installing fences on a snow or ice foundation.

5.1 General fence design considerations

According to Tabler (1991a), there are three basic fence design features that hold true irrespective of where the fence is installed:

1. Fence orientation
2. Fence porosity
3. Bottom gap

Following, we consider each of these in turn.

5.1.1 Fence orientation

Where possible the fence should be oriented so that the fence line is perpendicular to the prevailing wind. In many Antarctic applications, topography does not interfere with installing the fence in this preferred orientation.

5.1.2 Fence porosity

Tabler (1994) shows that the maximum capture efficiency of a snow fence is achieved with a 50% porous fence. The standard rolls of plastic fencing manufactured for snow-fence applications are 50% porous (Figure 18).

Figure 18. Example of standard fencing material.



They can be installed using posts driven into the snow or attached to a truss framework (see Figure 14 in Tabler 1991a.). Truss-type fences are also constructed with horizontal slats spaced to provide 50% porosity, such as Wyoming and Swedish snow fences.

5.1.3 Bottom gap

This feature of a snow fence is often the most overlooked but is vitally important to proper fence performance. This is the spacing between the ground and the beginning of the fencing material as illustrated in Figure 19 and needs to be 10%–12% of the overall height of the fence ($0.10H$ – $0.12H$). This bottom gap causes the wind hitting the fence to speed up near the ground and to scour the snow clear of the area immediately under and around the fence, thereby preventing the bottom of the fence from becoming buried during the season. By preventing the burial of the fence, the capture efficiency of the fence remains at nearly 100% until it reaches saturation (the point at which it no longer captures drifting snow).

Figure 19. Detail of snow-fence design illustrating the bottom gap and slat spacing. The bottom gap is 10%–12% of the overall height of the fence, H .

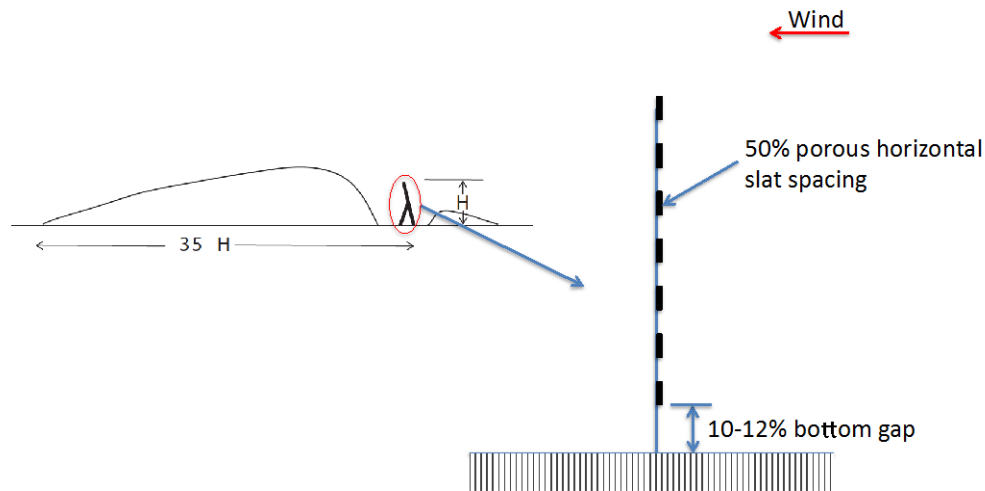

As illustrated in Figure 19, for horizontal slats attached to a truss structure, the slats cannot extend all the way to the ground. When hanging fencing (e.g., the material shown in Figure 18) on posts, the fencing must not extend all the way to the ground or snow surface. For example, for 1.2 m (4 ft) wide fence material, the bottom gap should be 12–15 cm; and the overall fence height will be about 1.4 m tall to allow for the bottom gap.

5.2 Fence designs

There are a huge variety of fence designs documented in the literature. Here we consider designs that are applicable for use in Antarctica and, in particular, can be installed annually on a snow or ice foundation and be completely removed and stored during winter months. The main consideration for any of these designs is providing proper anchoring in the snow or ice to prevent the fences from being destroyed or blown away by the wind. Ideally, the anchoring system is also completely recoverable so that nothing is left behind above or below the surface when the fences are removed. Typically, the fence structures have been designed to withstand 160 km/hr (100 mph) winds; and we designed the following recommended anchoring systems presented here to withstand these winds. It is important to review local conditions to determine if the winds are higher than this and if the fence system design needs revising.

5.2.1 Post design

The most ubiquitous snow-fence design is fencing material attached to steel posts driven into the ground. In this case, the posts can be driven into a snow surface; however, this is not so practical on ice foundations (e.g., the Ross Ice Shelf). For installation in ice, holes need to be drilled into the ice, posts dropped into the hole, and then water and snow packed into the hole to allow the post to freeze in place. Removal is also problematic for such an ice installation. In snow, the post can usually be easily extracted. In ice, they need to be chipped or cut out. Consequently, we do not usually recommend using a post design on an ice surface.

The principal concern with any fence system is proper anchoring in consideration of the winds the fence will be subjected to. For a 1.5 m fence, 2.1 m (7 ft) metal posts are adequate. The posts need to be driven 0.6 m (2 ft) into a well-compacted snow with a snow strength greater than about 120 kPa (Tabler 1991a); loose snow will not provide the overturning resistance to properly anchor the fence. To determine the approximate strength of the snow, Colbeck et al. (1990) provides an approximate correlation between qualitative snow hardness scale and measured compressive snow strength. Table 15 summarizes this. Based on Table 15, adequate snow strength is associated with snow that is “pencil” to “knife” hardness. Such snow fences are routinely used at Antarctica camps such as West Antarctic Ice Shelf (WAIS) Divide and PIG. Typically, staff removes the fencing and metal posts annually and stores them at the camp over the winter.

Table 15. A correlation of snow hardness to snow strength provided by the International Snow Hardness Scale (Colbeck et al. 1990).

Snow Hardness Scale*	Compressive Snow Strength (kPa)
1. Fist	0–1
2. 4 Fingers	1–10
3. 1 Finger	10–100
4. Pencil	100–1000
5. Knife	>1000

* Similar in concept to the Mohs' scale for hardness of geologic materials. The strength is determined by gently pushing each item in the snow. The hardness is the first that penetrates the snow.

For a 1.5 m fence, the post spacing should be 1.4 m to prevent the posts from bending in the wind (Tabler 1991a). The fencing material can then be attached to the posts, allowing for a 15 cm gap between the bottom of the fencing and the ground. This practice has been successful in Antarctic camps and at McMurdo Station, demonstrating that the post anchor works over the summer season for these relatively short fences.

Post fences larger than 1.5 m need additional consideration. First, owing to the effort associated with installing tall vertical posts, we recommend oversizing the height of the posts to account for annual snow or ice accumulation, such that posts can be used for several seasons before resetting. For example, if the annual accumulation is 9 cm and a design life is 15 years, the posts should initially be installed with at least an extra 1.35 m height above grade. Then, annually the fencing material is attached, allowing for the appropriate 10%–12% bottom gap for the overall fence height. Using this strategy, the posts can be left in place over the winter; and only the fencing needs to be removed annually though the drifts formed by the fences will still need to be managed appropriately (i.e., removal or feathering into surrounding terrain, etc.).

To install the posts, a posthole digger mounted on a 3-point hitch on a tractor and powered by a power take-off can be used. For snow, an off-the-shelf auger can be used with the standard pilot bit installed on the boring end. The auger can be used for installation in ice, also, though we recommend modifying the pilot bit on the auger to cut in ice. Figure 20 shows the pilot bit replaced with a triangular spade bit that is much more effective at cutting in ice than the standard tapered spiral bit. The triangular bit is not an off-the-shelf tip; it is fabricated from a 0.64cm (0.25 in.) steel plate and is welded to a post that inserts into the auger head. The beveled edges of the triangular tip create a knife edge on each side of the bit.

Figure 20. A modified auger bit used for cutting in ice (Haehnel 1998). The auger shown has a 30 cm (12 in.) diameter.

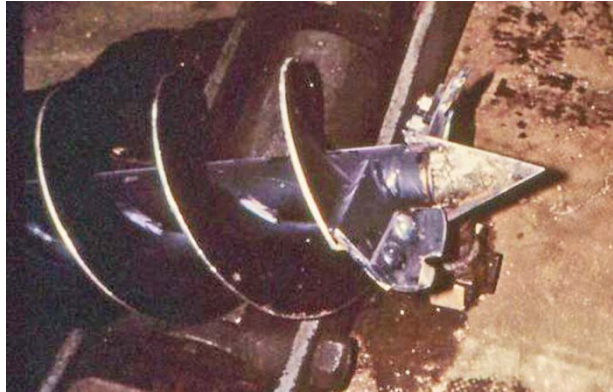

Table 16 provides the required post diameter as a function of fence height to provide adequate strength to withstand a design wind of 45 m/s (100 mph). A 30 cm posthole digger will provide a hole large enough to accommodate the full range given in Table 16.

Table 16. Approximate post diameters required to support 50% porous snow fences in 45 m/s (100 mph) winds. Values are for Douglas fir posts at 3.7 m on center in soil with average bearing strength of 120 kPa. (Tabler 1991a).

Fence Height (m)	Diameter at Butt (cm)
1.8	16
2.4	19
3.0	22
3.7	26
4.3	29

If synthetic fencing is used, it needs to be tensioned according to manufacture specifications before attaching to the vertical intermediate posts. To facilitate this, the end posts need to be braced to allow for the tension forces. This can be done with cross bracing between the top of the end post and the ground of the next post. Tensioning can be accomplished with hand winches or come-a-longs attached to one end of the synthetic fencing with the other end securely fastened to the opposing end post.

Also, if synthetic fencing is used, it needs to be ultraviolet resistant and be prevented from rubbing on the vertical support posts, which can cause damage. Tabler (1991a) recommends fastening elastomeric roofing membrane (EPMD) to the vertical posts between the post and fencing and be-

tween the fencing and batten. The batten should be rigid and can be secured tightly to the vertical posts with steel banding.

As mentioned previously, the fencing will need to be taken down and reinstalled annually to prevent the fencing from becoming buried during the winter.

Though post-construction fences larger than 1.5 m are effective in soils, there is no documented evidence of their long-term performance in ice and snow. Furthermore, experience for soils does not directly translate to installation in ice and snow. Because of the creep behavior of ice and snow, over time the posts may slowly overturn in the snow if the fence is exposed to constant winds. As this is an important topic, we discuss in more detail in Section 5.2.3, issues related to anchoring.

5.2.2 Truss fences

There are several truss snow-fence designs employed in the field, including Swedish, Wyoming, buck and pole, and Tensar wood-frame support fences. As Tabler (1991a, 1994) has documented these well, we will not provide an exhaustive review here. Overall, these are 50% porous designs and provide comparable performance to each other. Selecting one design over another comes down to design requirements and, in some measure, preference. All of these are typically deployed on frozen soil, and most of them are permanent structures (i.e., they are installed once and are not removed and reinstalled annually). As Antarctic camps require annual installation and removal to prevent burial of the fences in snowdrifts, fence designs must allow for annual removal and winter storage.

A design that was successful on the Ross Ice Shelf near McMurdo, Antarctica, was a 1.8 m Wyoming-style fence. This was modified so that it was collapsible for shipping and storage, and the anchoring system was designed to work in ice. Section 5.2.3 discusses this design further and Figure 21 shows a section of this fence in the fabrication shop and the deployed fence in the field. To collapse the fence shown in Figure 21, a bolt securing the rear truss leg to the bottom skid is removed. The truss leg then folds flat against the front of the fence, and the skid rotates up against the front of the fence. The entire assembly then lays flat for storage or transportation.

Figure 21. Wyoming snow fence (a) section and (b) installed on the Ross Ice Shelf, McMurdo, Antarctica.



The detachable skid shown in Figure 22 is included because during warm periods, the ice surface can melt, and the bottom of the fence may sit in melt pools. Later in the season these melt pools may refreeze, locking the skid into the ice. The skid is secured to the fence sill (bottom member of the truss) by two 0.5 in. diameter lag screws extending through the sill into the skid. Removing the lag screws allows separation of the fence from the skid leaving only the skid behind.

Figure 22. Details of the snow fence shown in Figure 21, including the anchoring system. All dimensions are in inches or degrees.

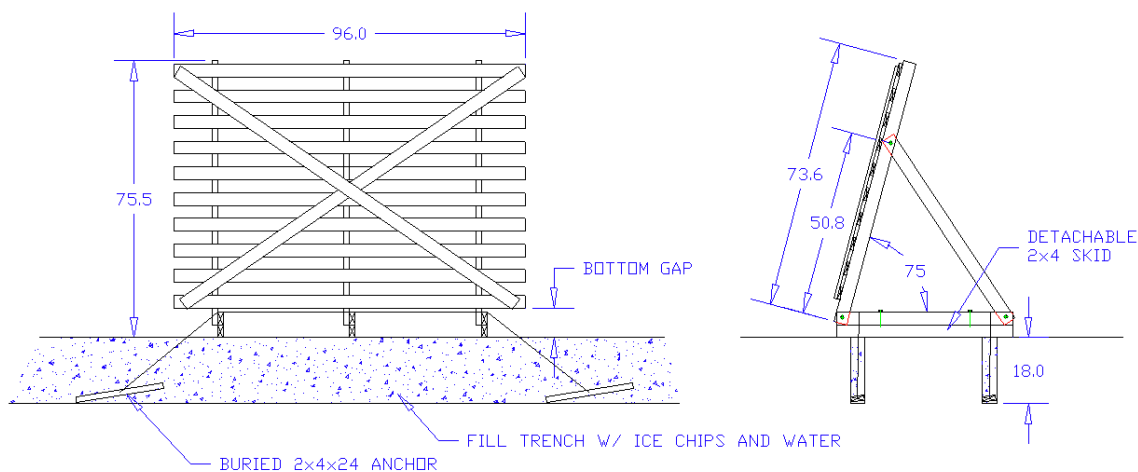

5.2.3 Anchoring

Anchoring in ice and snow requires special considerations. Both are visco-elastic materials; as a result, they behave quite different for quick (short-term) loads than they do to long-term loads. For a short-term load (minutes to hours), these materials behave like a brittle material; and when the failure load is exceeded, they fail catastrophically. As the anchor is pulled out of the ice or snow, large chunks of ice or snow sometimes “explode” out with the anchor (Bogie and Fortini 2010). However, these materials also exhibit creep behavior under long-term loading that lasts days to months (or longer), wherein the anchor is very slowly pulled through the ice or snow. The higher the load on the anchor, the faster the anchor is displaced. For anchors that will be placed for several months or longer, the key is to keep the load on the anchor low enough that the movement is small enough to be considered acceptable (i.e., no more than a few mm). Otherwise, the tension in the anchoring system needs monitoring and retightening on a regular basis.

For snow fences, we are more concerned with the long-term response of the anchor, and therefore we will not consider short-term anchor strengths, such as data associated with recreational climbing and rescue operations (or mountaineering) in regions where snow or ice are the only materials to anchor in (e.g., Bogie 2005; Bogie and Fortini 2010; Candela and Latosuo 2012). We will consider separately anchors for snow and ice.

5.2.3.1 Anchors in ice

In the present work, we will assume the loading applied by the anchors to the ice is uniform compression. This is a conservative approximation as the stress will not actually be uniform throughout the ice as the load bearing ice will be a cone extending from the buried anchor to the surface. Yet, this approximation is sufficiently accurate for engineering purposes. To determine the performance of the anchor system in ice, we need to consider the material properties of ice.

Figure 23 provides a summary of the creep response of polycrystalline ice. This figure documents the deformation (strain rate) as a function of applied stress and temperature. The results presented here characterize the stress and strain in terms of the octahedral values, invariants of the principal stress and strain components.

Figure 23. Minimum strain rate of polycrystalline ice in uniaxial creep. The variation in ice response as a function of ice temperature is illustrated by the family of curves (Budd and Jacka 1989).

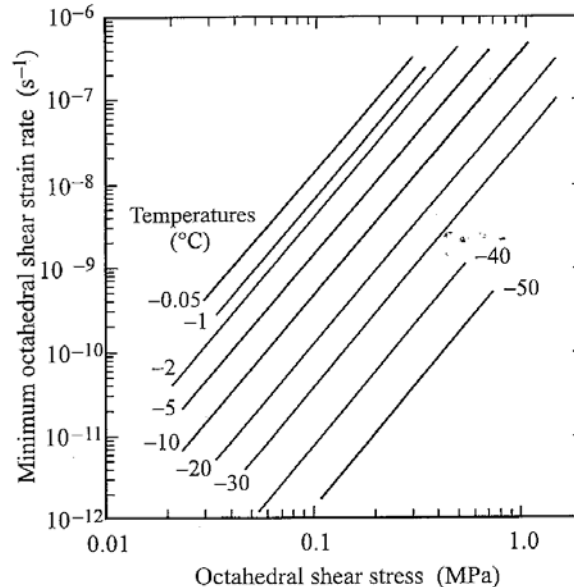

Such analysis allows generalization of the response of the engineering material to complicated load states. For uniaxial stress (i.e., uniform compression),

$$\tau_{oct} = \sqrt{2}/3 \sigma_1 = 0.47 \sigma, \quad \epsilon_{oct} = \epsilon_1/\sqrt{2} = 0.707 \epsilon \quad (17)$$

where

- ε_{oct} = octahedral strain,
- ε = compressive strain acting in the same direction as the compressive stress and the direction of load application,
- σ = compressive stress.

Because the ice creeps, we also need to know during the time, t , the load is applied, the expected anchor movement, Δy , that will result with the planned anchor burial depth, L . This is determined from

$$\Delta y = \dot{\varepsilon}Lt; \dot{\varepsilon} = \varepsilon/t \quad (18)$$

Below, we illustrate how this is applied for anchor design to the truss fence introduced in Section 5.2.2 (Figures 21 and 22). Figure 22 shows the details of the anchoring system.

We will assume the design of the deadman anchor is a wood anchor $4 \times 7.5 \times 60$ cm long ($2 \times 4 \times 24$ in. long) as depicted in Figure 24. The approximate effective area of this anchor is 0.054 m^2 . For the present, we assume a design load on the anchor of 10 kN and an ice temperature of -10°C or colder. As indicated in Figure 22, the planned burial depth is 45 cm (18 in.). We recommend a burial depth of at least 30–45 cm as increased depth increases the amount of load bearing material that the anchor acts against, thereby increasing strength. Furthermore, the deeper the anchor is buried, the less influence short-term changes in the surface air temperature or incoming solar radiation have on the strength of the ice surrounding the anchor.

Figure 24. Dead man anchor used for snow fences shown in Figure 21.

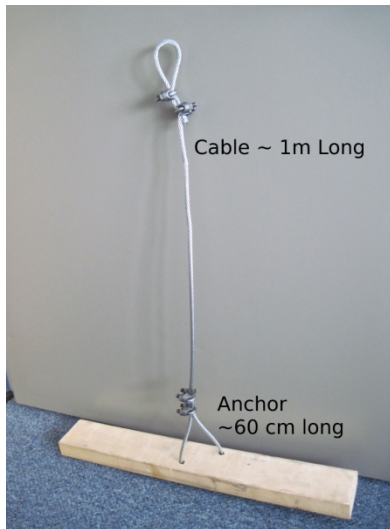

The approximate uniaxial shear stress is then

$$\sigma_1 \approx 10 \text{ kN}/0.054 \text{ m}^2 = 0.18 \text{ MPa.}$$

The octahedral shear stress is computed from equation (17):

$$\tau_{oct} = 0.47 (0.18 \text{ MPa}) = 0.08 \text{ MPa.}$$

From Figure 23, we find the octahedral strain rate is $2 \times 10^{-10} \text{ s}^{-1}$. By applying equation (17), the uniaxial strain rate is

$$\dot{\epsilon}_1 = 2 \times 10^{-10} / 0.707 = 3 \times 10^{-10} \text{ s}^{-1}.$$

The planned anchor burial depth is 45 cm (18 in.) as indicated in Figure 22. With an operational season of 90 days, the anchor movement is expected to be

$$\Delta y = 45 \text{ cm}(3 \times 10^{-10} \text{ s}^{-1})(90 \text{ days} \times 24 \text{ hr/day} \times 3600 \text{ s/hr}) = 0.1 \text{ cm.}$$

This anchor movement is considered acceptably small, and the anchor design is adequate.

Table 17 provides a summary of deflection for varying anchor load, ice temperatures, and loading times for the anchor depicted in Figure 24. This table provides a conservative upper limit of the deflection for this anchor

as it does not account for the distribution of the load through the ice from the anchor to the surface (distributed through a cone of ice not a rectangular prism above the anchor).

Table 17. Estimated movement of an anchor of the configuration shown in Figure 24 buried in ice to a depth of 45 cm (18 in.). Strain rate was determined from Figure 23 and deflection was determined from equation (18). This assumes the load is held nearly constant on the anchor during the load time period. Conditions shaded red represent unacceptably high anchor movement greater than 0.4cm.

Ice Temperature (°C)	Anchor Movement (cm)		
	30-Day Loading	90-Day Loading	180-Day Loading
Anchor Load = 5 kN			
-1	0.03	0.1	0.4
-5	0.01	0.04	0.1
-10	0.003	0.01	0.03
-20	0.001	0.004	0.01
Anchor Load = 10 kN			
-1	0.3	1	3
-5	0.1	0.4	1
-10	0.03	0.1	0.3
-20	0.02	0.06	0.2
-30	0.003	0.01	0.03

Note that from Table 17, we see that to keep the anchor deflection to 0.1 cm or less for an anchor that has to serve for 180 days in ice that is approximately -10°C , the load on the anchor will need to be cut in half to 5 kN, requiring twice as many anchors to be installed.

Detailed information about this anchor design is as follows. We cut two parallel trenches 45 cm (18 in.) deep in the ice the entire length of the fence line; in this case, we used a Vermeer trencher. Then with 1 m long attached cables (Figure 24), we dropped the anchors into the trench with the cable loop extend above grade approximately 40 cm; and we backfilled the trench by using the tailings (ice chips) from the trenching process. Lacking water, one must compact these tailings to accelerate sintering of the ice particles. We spaced the anchors so that they fell on each side of the fence base as shown in Figure 22. If there is sustained sub-freezing weather, water can be added to the tailings to accelerate the freeze-back of the trench. Compacting the tailings and freezing the water in layers (or lifts) will provide more uniform compaction and anchor strength and quicker freezing over the full depth. Depending on the temperature, it may take 24

hours or longer for the water to fully freeze or for the compacted snow and ice to regain strength.

Once we set the anchors, we could install the fences between the anchors and secure them by running connecting ratchet tie-downs between the exposed anchor loops. For securing the 1.8 m tall fence shown in Figure 22, we used 3 m (10 ft) long tie-downs rated for 15 kN (3335 lb). The anchor cable was 0.64 cm (0.25 in.) in diameter and rated for a 31 kN (7000 lb) test strength. We designed this anchoring system for a 110 km/hr (70 mph) design wind speed. For a taller fence or higher design winds, a more robust anchoring system needs to be designed (i.e., doubling the number of anchors used).

One concern with this anchoring system is that sunlight along with warm air temperatures can weaken the ice and allow melt pools to form around the anchors, compromising the anchor strength. The critical air temperature when this starts to be a problem is above -5°C (Weatherly and Helble 2010). Reducing the sunlight absorbed by the ice surface can reduce melting of the ice. During warm periods when the air temperature is above -5°C , covering with fresh snow the areas where the anchor cables enter the ice will help increase the surface albedo and will reduce solar heating and melting. If there is ample drifting snow that accumulates around the base of the fence, this may not pose an issue.

To ensure the fences stay secure, the tensioning on the tie-downs should be checked often, especially during warm weather, as loss of tension may indicate initiation of failure of one or more anchors or of excessive creep in the ice.

We successfully removed these anchors by cutting parallel trenches on either side of the anchor line and used a backhoe, excavator, or blade to break the vertical ice wall into small enough pieces to remove the anchors. The ice encasing the removed anchor could be further broken up or melted to recover the anchor for subsequent use.

For repeated installation of the fences in the same location, the anchors can be left in place though adequate cable length will need to be provided to allow for annual ice and snow accumulation. Equally important is providing a means to locate the anchor cables after the winter.

5.2.3.2 Anchors in snow

Very limited information is available on long-term anchoring in snow. The most comprehensive study was conducted by Kovacs (1967). In this study, 15–36 cm diameter steel plates were buried in snow at depths ranging from 0.6 to 3 m (typical density of the undisturbed snow was 0.4–0.5 g/cm³). They were installed by drilling a 1.2 m diameter hole into the snow to the desired depth, dropping the plate into the hole—with a threaded rod attached to transfer the anchor load to the surface—and backfilling the hole with compacted snow. The snow was compacted in 30 cm lifts; the compacted snow density ranged from 0.48 to 0.55 g/cm³. After burial, the snow was allowed to sinter for 8–17 days at –20°C to –25°C before a load was applied. Loads ranging from 45 to 220 kN were applied to the anchors, and the rate of anchor pull out was monitored for each applied load.

These tests showed that with burial depths as shallow as 60 cm, a 30 cm diameter plate (effective surface area* of 0.07 m²) can hold a load of over 50 kN with minimal movement over short time scales (i.e., 5–10 minutes). This is consistent with results for snow anchors used for mountaineering where snow stakes driven in to the snow (effective surface area of 0.04 m²) with burial depths of only 30 cm can support loads of 5 kN or more (Bogie 2005) depending on the snow conditions.

However, the results that are most germane to snow-fence anchoring are for loads applied over an extended period, in some cases longer than a year. Kovacs (1967) conducted long-term tests wherein 30 cm diameter plates were buried 2.4 m, and a static load of 22 and 50 kN was applied. For the 22 kN load, the anchor moved 1 cm in over 320 days. Increasing the load to 50 kN, the same anchor movement was achieved in about 40 days. These tests results demonstrate the profound effect that lowering the load on the anchor reduces anchor movement; in this case, approximately doubling the load on the anchor increased the rate of movement of the anchor by a factor of eight.

Also, many tests involving short-term loading (Kovacs 1967, Bogie 2005, Bogie and Fortini 2010, Candela and Latosus 2012) confirm that increasing both anchor area and depth increases the strength of the anchor. Furthermore, hard (e.g., pencil to knife hard), undisturbed snow provides

* Surface area in contact with the snow in the direction of loading.

much more resistance to deformation and a stronger anchor than snow that has been excavated out and repacked over the anchor. Finally, often it is not the snow but the anchor itself that fails, either by bending and being pulled out of the snow or failure of the attachment point of the cable to the anchor. Therefore, the anchor device also has to be designed to withstand the intended load.

Applying these lessons, we make the following recommendation for a conservative anchor design in snow. Rather than pulling the anchor vertically through 2.4 m of snow as was done by Kovacs (1967), we recommend pulling it through the same distance of snow but at an angle as shown in Figure 25. A 30 cm diameter \times 1.2 m long posthole auger (as shown in Figure 20) can be used to cut holes in the hard snow to set the anchor. Use an anchor 28 cm in diameter constructed from a 2.5 cm thick steel plate. Attach to the plate a cable or chain tether with at least 30 kN test strength (e.g., 0.64 cm [0.25 in.] diameter stainless steel cable). We suggest that the length of the tether is at least 3 m. Once the anchor is dropped into the bottom of the hole, either pull the tether through the snow (if the snow is soft enough) or cut a slot in the snow so that the tether lays about 30° from horizontal in the snow (2 m from the hole centerline). Once a load is placed on the anchor, the plate will pull up against the wall of the hole. Though not necessary, the hole can be back filled with compacted snow. Based on the data provided in Kovacs (1967), an anchor so constructed should provide at least 10 kN of resistance in pencil to knife hard snow with minimal (≤ 1 cm) deflection over a 90-day period (i.e., a 3-month summer camp season). Enough anchors of this design will secure the structure against lateral forces and overturning moments acting on the fence with an appropriate design modulus applied.

Figure 25. Configuration for anchoring in snow.

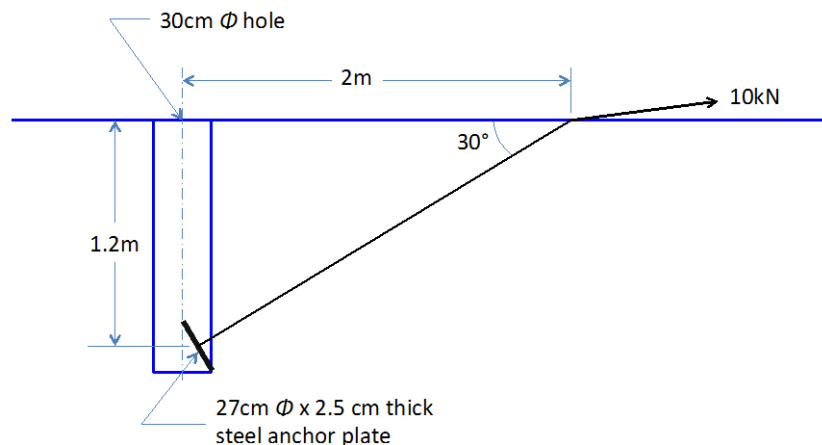

We caution that we provide the above anchor design based on the limited data available. The user may consider alternate designs, and further work is required to improve understanding of the performance of anchors set in snow over a long-term (i.e., 90 days or more).

5.3 Fence design procedure

Here we provide example calculations for a fence that would satisfy the fence design in Section 4. We will continue to use the PIG camp as a case study to demonstrate how to determine the design wind and wind loads. In particular, we select the full-season design shown in Table 12: a 3.8 m tall, 50% porous fence.

In this exercise, the length of the fence is immaterial; the main design consideration is making the anchor strong enough to withstand the design wind. The steps to complete this are as follows:

1. Determine the design wind for the location.
2. Determine the wind loads on the proposed structure.
3. Determine the resistance loads and moments to prevent overturning of the proposed structure. These are needed to determine the anchor design.

A final step would be to size structural elements and anchors to withstand the forces determined in above Steps 2 and 3 with an appropriate factor of safety. Tabler (1991a, 1994) has refined the structural design for post and truss type fences to withstand a 45 m/s (100 mph) design wind, and Table 16 provides structural design (post diameter) for the post fence. Appendix E gives the structural design for a truss fence.

Because steps one and two are independent of structure (post or truss design), we will compute those values once for both designs. Then we will provide separate calculations for Step 3 for each design.

As discussed, there is very limited information on the performance of anchors in snow subjected to long-term loading (e.g., loads that last weeks to months), and at present there is no information on required post embedding depth in snow. Therefore, we use the limited data we have to propose an anchor design for a truss fence. Further work is required to determine needed embedded depth for post structures. In the absence of this guidance, we recommended guy anchors be used if post structures are implemented.

5.3.1 Design wind

Since we have already demonstrated in Figure 10 that at PIG camp the wind comes from a single direction, determining the design wind is simplified. Therefore, using just the wind data from PIG with no correction for vector (direction), Figure 26 presents a probability plot of the wind speed for this site. This is the best data that we have for that site during the period the camp operates. This data spans three seasons (2008, 2009, and 2011). The maximum wind speed recorded during this time was a little over 30 m/s.

Figure 26. Probability plot of wind speed for three operational seasons at Pine Island Glacier camp (2008, 2009, and 2011). The maximum wind speed recorded over these seasons was 30.7 m/s.

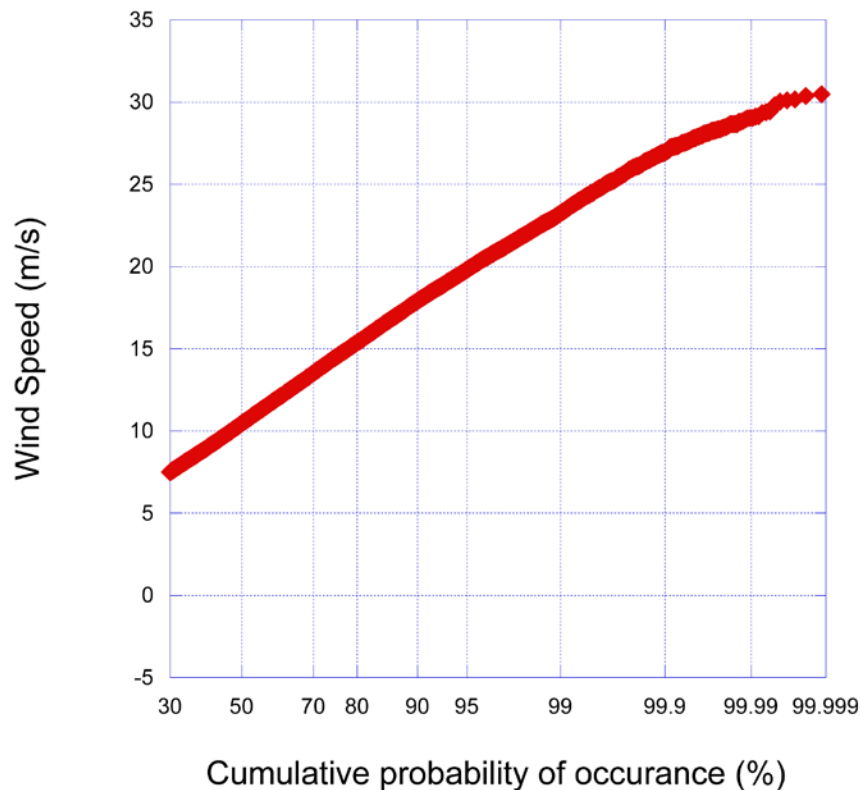

To be consistent with Section 4, we use a PE of 5%, which gives a design modulus of $K \approx 1.49$ (Table 3). Ordinarily one would use the 5% exceedance level wind speed (95% cumulative probability in Figure 26), which is 20 m/s. However, Figure 26 is a compilation of only three years of data. For such a short data set, we will compute the design wind speed based off the more conservative value of the maximum wind speed: 30.7 m/s. From this, the design wind speed is then $U_{des} = 1.49 \times 30.7$ m/s

= 45.7 m/s (102 mph). For locations where a longer period of record is available (e.g., 8–10 years or more), use of cumulative probability wind speed consistent with the design PE would be more appropriate.

5.3.2 Wind load

The force of the wind on the structure is

$$F_w = HWP \quad (19)$$

where

- F_w = wind force (N),
- H = structure height (m),
- W = structure width (m),
- P = wind pressure on the structure (Pa).

The wind pressure is a function of the air density and the wind speed with air density a function of elevation above sea level and the air temperature. Tabler (1994) tabulated the functional dependence of wind pressure on the incident wind speed (reported at the standard 10 m height), elevation, and air temperature. Appendix E reproduces these tables for use in calculating the wind pressure. Table E1 provides the wind pressure at sea level and 20°C (standard temperature and pressure conditions or STP). Also, included in this table is the height at which the force acts (Z_f = moment arm), needed for fence anchor design (next section). Table D2 provides a correction factor to the wind pressure for temperatures and elevations that differ from STP conditions provided in Table D1. Therefore, the correct wind pressure for use in equation (19) is determined as follows:

$$P = C_{E,T}P_{STP} \quad (20)$$

where

- $C_{E,T}$ = correction factor to wind pressure for elevation and temperature,
- P_{STP} = wind pressure at STP (Pa).

Applying this to the example at hand, we use the design wind in Table E1 of 45.7 m/s or 165 km/hr. For a 3.8 m tall snow fence, $P_{STP} = 901$ Pa; the moment arm (Z_f in Table E1 of appendix E) for the force is 2.09 m. The PIG site is essentially at sea level; from the temperature records we find

the minimum and maximum values are -46°C and 5°C , respectively. Figure 27 shows the probability of these temperatures over the recorded periods. For this analysis, we will use a lower temperature of -40°C , which gives an elevation and temperature correction factor $C_{E,T} = 1.26$. For a complete design, a detailed review of a design temperature should be conducted to determine the probability of temperatures below -40°C when the fence has been erected. For now, we assume temperatures lower than -40°C are experienced during the very start of the season before substantial camp construction has been completed.

Figure 27. Summary of recorded temperature data at the Pine Island Glacier camp.

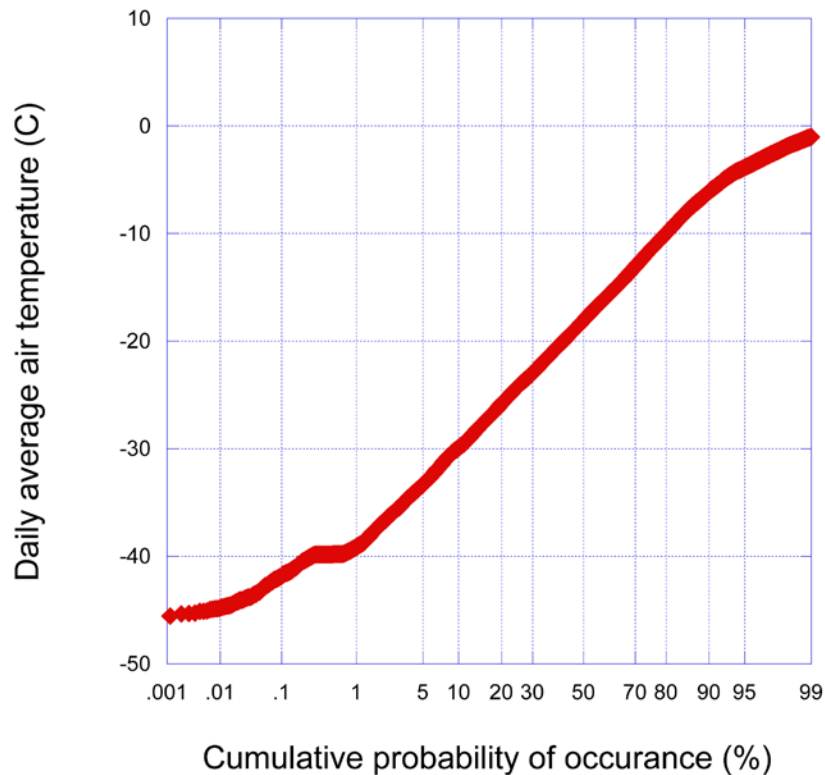

Based on the forgoing, the wind pressure is

$$P = 1.26 \times 901 \text{ Pa} = 1140 \text{ Pa}.$$

To apply equation (19) to determine the force, we need to determine the effective width of the structure. For a post design, this will be the distance between posts. For a truss design, it is the width of each fence section. These details will be determined in the following sections. For now, we will simply compute the force per unit fence width

$$F_w/W = 2.8 \text{ m} \times 1140 \text{ Pa} = 3190 \text{ N/m.}$$

5.3.3 Resistive loads and moments

To determine the anchor loads, we need to know the overturning moment, M , which is determined from

$$M = Z_f F_w \quad (21)$$

Where Z_f is the moment arm.

5.3.3.1 Post design

For this, we will consider the section width as the distance between two poles. From Tabler (1991a) and Table 16, we see that the post spacing should be 3.7 m. Therefore, the force per section is

$$F_w = 3190 \text{ N/m} \times 3.7 \text{ m} = 11.8 \text{ kN per post.}$$

The moment arm for a 3.8 m fence is provided in Table D1 and was determined in Section 5.3.2: $Z_f = 2.09\text{m}$. So for this case

$$M = 2.09 \text{ m} \times 11.8 \text{ kN} = 25 \text{ kN-m.}$$

This is the resistive moment that the base of the post buried in the snow and ice needs to provide to prevent overturning of the fence.

5.3.3.2 Truss design

Appendix F provides standard plans for a truss design fence of various heights. The section width of these fences is 4.87 m; therefore, the wind force is

$$F_w = 3190 \text{ N/m} \times 4.87 \text{ m} = 15.5 \text{ kN,}$$

and the overturning moment is

$$M = 2.09 \text{ m} \times 15.5 \text{ kN} = 32.5 \text{ kN-m.}$$

5.3.4 Anchor loads

Here we compute the number of anchors required for a truss fence to resist the loads presented in Section 5.3.3. Similar methods can be used to determine the anchor design for a guyed post fence; we do not provide example calculations for that case.

Figure 28 shows the force balance on the fence, including the anchor forces. The anchors need to provide both a lateral force (Anchor_x) and a vertical force (Anchor_y). Applying a standard statics analysis, the sum of the forces in the x (horizontal) direction need to equal zero and the moments about the back corner of the fence sill (point O in Figure 28) need to sum to zero. For this analysis, we will assume the design modulus, $K = 1.49$, consistent with Section 4, and compute the minimum number of anchors, N , required per fence.

Figure 28. Geometry and force balance of wind loads acting on a truss fence.

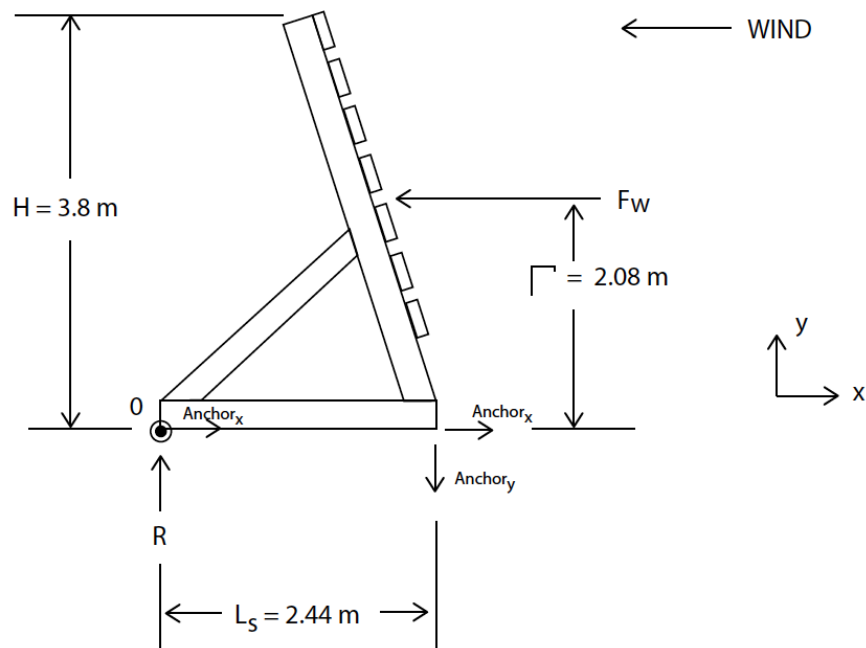

$$\Sigma F_x = 0$$

$$F_w = N \text{Anchor}_x \quad (22)$$

Initially, we assume that we will require two anchors on each of the fence truss frames, one on the upwind side and one on the lee side; therefore, $N = 6$ for the entire fence section. Applying equation (22), we determine the load on each anchor:

$$\text{Anchor}_x = 15.5 \text{ kN}/6 = 2.6 \text{ kN per anchor.}$$

Now evaluating the moments,

$$\Sigma M_0 = 0$$

$$M = N/2 \text{ Anchor}_y L_s \quad (23)$$

where the sill length, $L_s = 2.44 \text{ m}$, is specified in Figure 28 as obtained from Appendix E. Using equation (23), we determine the vertical load for each anchor is

$$\text{Anchor}_y = 32.5 \text{ kN-m}/(6/2 \times 2.44 \text{ m}) = 4.4 \text{ kN per anchor.}$$

The total load on the upwind anchors is the vector sum of these two anchor loads: 5.1 kN. The leeward anchors need to resist a horizontal load of 2.6 kN.

If we use the anchor design suggested in Section 5.2.3, *Anchors in snow*, the maximum design load the anchor can resist is $10 \text{ kN}/K$. With the factor of safety $K=1.49$, the maximum load each anchor is designed to resist is $10 \text{ kN}/1.49 = 6.7 \text{ kN}$. This indicates that the load on all of the anchors is below the maximum design load; and this design is acceptable, though the number of anchors required per fence section is considerable.

6 Summary and Recommendations

In this handbook, we provide information and methods to aid in the design and application of measures for managing snowdrift accumulations at Antarctic research camps. Because the local wind direction varies little for a vast majority of the continent, our main focus is on management strategies for wind that is mainly from one direction. The strategies suggested here might not be applicable to locations where the wind direction varies widely. Though this handbook is specifically developed to address drifting problems in Antarctica, many of the principles outline herein should be applicable to Arctic camps (e.g. Greenland).

This handbook focuses on measures for preventing snow from accumulating on structures, buildings, equipment, cargo, etc., by using drift protection measures (berms or fences) that trap the snow upwind of the camp or snow shelters that deflect the blowing snow around these resources. We do not discuss minimizing the effects of drifts accumulated on these resources using other methods, such as building orientation, camp layout, etc. Further work could be done to expand this document to include building orientation and camp layout.

We review methods for determining the prevailing wind direction and the severity of the snow-drifting problem for the planned camp. This information is used to size protection methods based on the planned footprint of the camp. Figure 1 outlines the step-by-step procedure to design a snow drift protection method.

To illustrate this procedure, we followed these methods for a case study of the PIG field camp. Using available meteorological data, we determined that the snow drifting severity at the PIG camp is “Moderately severe.” Using this information, we developed and reviewed several snow management strategies. As part of the review, we considered how to manage the snow at the site; and we found that the level of effort to manage many of these proposed protective measures for a camp of this size that experiences “Moderately severe” snow drifting can easily exceed the snow moving resources (i.e., a Tucker and hand shovels) presently available at the camp. PIG may need additional resources, such as larger equipment (e.g., a D6

Caterpillar Dozer), depending on the protection method selected for use at the site.

Future work should address equipment and cargo storage, tent and building siting, and overall camp layout to minimize the impact of frequent drifting events on the efficient operation of the research camp. We anticipate that this future research would explore the use of snow protection methods and snow shelters to protect more critical resources and would provide guidance on camp layout to reduce drift effects on less critical resources. Such guidance can help develop a drift management plan for camps with limited equipment and personnel resources.

Though windbreaks or snow shelters discussed here show promise as a means to protect buildings and equipment from snowdrifts, unanswered questions remain concerning the performance of snow shelters. In particular, we do not know the rate of drift formation as a function of snow transport nor the total amount of transport that leads to the windbreak being overwhelmed. We recommend follow-up work to assess the performance of windbreaks. This would require documenting the snow transport as snowdrifts accumulate on the structure and noting the point at which the structure is overwhelmed (drifting snow is deposited behind the structure) and the amount of transported snow that creates that condition. We anticipate this could be a combined wind tunnel and field study, the latter of which could be carried out either in the northern U.S. or at a site in Antarctica. With this information, windbreak sizing can be readily determined based on the drift severity classification determined for a campsite (similar in fashion to how berms and snow fences can be sized for a specific application).

Snow-fence design has largely evolved for application in temperate regions where the accumulated snowdrifts melt away during the summer season and the fences are founded on soil. Therefore, we focus specifically on the use of snow-fence technology in glaciated or Polar Regions where the fence is founded on ice or snow and the accumulated snow does not melt away at the end of the operational season; and we review how these effects alter fence design and application. As part of this, we discuss the state-of-the-art in anchors for long-term loading in ice and snow and how this may be applied to anchoring snow fences in Antarctica. Relatively little work has been done on long-term anchoring systems in these mediums. Based on the limited available research, we provide some recommendations for an-

choring in ice and snow; but it is clear that limited understanding of the creep behavior of snow loaded by anchors and posts hampers the ability to properly design anchoring systems for post and truss snow fences founded on a snow surface.

We recommend follow-up work to better understand the anchor performance in snow subjected to long-term loads (loads lasting weeks to months). This research could use finite element modeling of anchors and posts placed in the snow, using a creep constitutive law for snow, and subjecting the structures to loads typical of snow-fence applications. The performance for varying snow density and temperature would need to be explored to provide sufficient range in the solution space to be applicable to the broad range of conditions typical of field applications. This will allow determining an estimate of anchor performance and acceptable embedment depth for posts. To validate these model results, we recommend conducting a limited field evaluation to confirm the model estimates of anchor performance for both posts and buried anchors. The proposed field evaluation would be limited in scope to a single post and single buried anchor configuration and to monitoring the deflection of the post and anchor over at least a 3-month period. The recommended density and hardness of the snow is at least 350 kg/m³ and pencil hardness.

As each of the above issues is addressed, we can add additional sections to this document and update the case study to include additional options for drift management.

References

- Bogie, D. 2005. *Snow Anchors*. White Paper. New Zealand: NZMSC Snow and Avalanche Committee.
- Bogie, D., and A. Fortini. 2010. Snow Anchors for belaying and rescue. In *Proceedings of the 2010 International Snow Science Workshop*, 310–317.
- Bromwich, D. H., A. J. Monaghan, J. G. Powers, J. J. Cassano, H. Wei, Y. Kuo, A. Pellegrini. 2003. Antarctic Mesoscale Prediction System (AMPS): A Case Study from the 2000–01 Field Season. *Monthly Weather Review* 131:412–434.
- Bromwich, D. H., Z. Guo, L. Bai, Q. Chen. 2004. Modeled Antarctic Precipitation. Part I: Spatial and Temporal Variability. *Journal of Climate* 17:427–447.
- Budd, W. F., and T. H. Jacka. 1989. A review of ice rheology for ice sheet modeling. *Cold Regions Science and Technology* 16:107–44.
- Candela, S. G., and E. Latosuo. 2012. Multiple linear regression modeling and the correlation between surface area, snow density and burial depth of improvised snow protection. In *Proceedings of the 2012 International Snow Science Workshop*. Anchorage, AK.
- Colbeck, S., E. Akitaya, R. Armstrong, H. Gubler, J. Lafeuille, K. Lied, D. McClung, and E. Morris. 1990. The International Classification for Seasonal Snow on the Ground International Association of Scientific Hydrology, International Commission on Snow and Ice. Boulder, CO: University of Colorado, World Data Center A for Glaciology.
- Cullather, R. I., D. H. Bromwich, and M. L. Van Woert. 1998. Spatial and temporal variability of Antarctic precipitation from atmospheric methods. *Journal of Climate* 11:334–367.
- Giovinetto, M. B., and C. R. Bentley. 1985. Surface balance in ice drainage systems of Antarctica. *Antarctic Journal of the U.S.* 20:6–13.
- Haehnel, R. B. 1998. *Nonstructural ice control*. CRREL Special Report 98-14. Hanover, NH: U.S. Army Cold Regions Research and Engineering Laboratory.
- Jairell, R. L., and R. A. Schmidt. 1999. Snow management and windbreaks. In *Proceedings of the Range Beef Cow Symposium XVI, 14–16 December, Greeley, CO*.
- Kovacs, A. 1967. *Feasibility study of buried anchors in polar snow*. Special Report 107. Hanover, NH: U.S. Army Cold Regions Research and Engineering Laboratory.
- Lazzara, M. A., L. J., Welhouse, J. E. Thom, J. J. Cassano, A. K. DeVivier, G. A. Weidner, L. M. Keller, and L. Kalnajs. 2013. Automatic Weather Station (AWS) Program operated by the University of Wisconsin-Madison during the 2011–2012 field season. *Antarctic Record* 57 (1): 125–135. Reprint #7005.

- Tabler, R. A. 1986. *Wind Loads and fence design*. Technical Report. Glenview, IL: Signode Corporation.
- Tabler, R. D. 1991a. *Snow fence guide*. SHRP-W/FR-91-106. Washington, DC: Strategic Highway Research Program, National Research Council.
- Tabler, R. D. 1991b. Snow transport as a function of wind speed and height. In *Cold Regions Engineering Proceedings Cold Regions 6th International Specialty Conference TCCP/ASCE 26–28 February, West Lebanon, NH*, 729–738.
- Tabler, R. D. 1994. *Design guidelines for the control of blowing and drifting snow*. SHRP-H-318. Washington, DC: Strategic Highway Research Program, National Research Council.
- Vaughan, D. G., J. L. Bamber, M. Giovinetto, J. Russell, A. P. R. Cooper. 1999. Reassessment of Net Surface Mass Balance in Antarctica. *Journal of Climate* 12:933–946.
- Weatherly, J. W., and J. Helble. 2012. *Projections for future air temperatures and melt season duration for McMurdo Station and Pegasus Runway*. ERDC/CRREL LR-12-8. Hanover, NH: U.S. Army Engineer Research and Development Center.

Figure A2. Annual P-E accumulation of S_{we} for the Antarctic continent (Cullather et al. 1998).

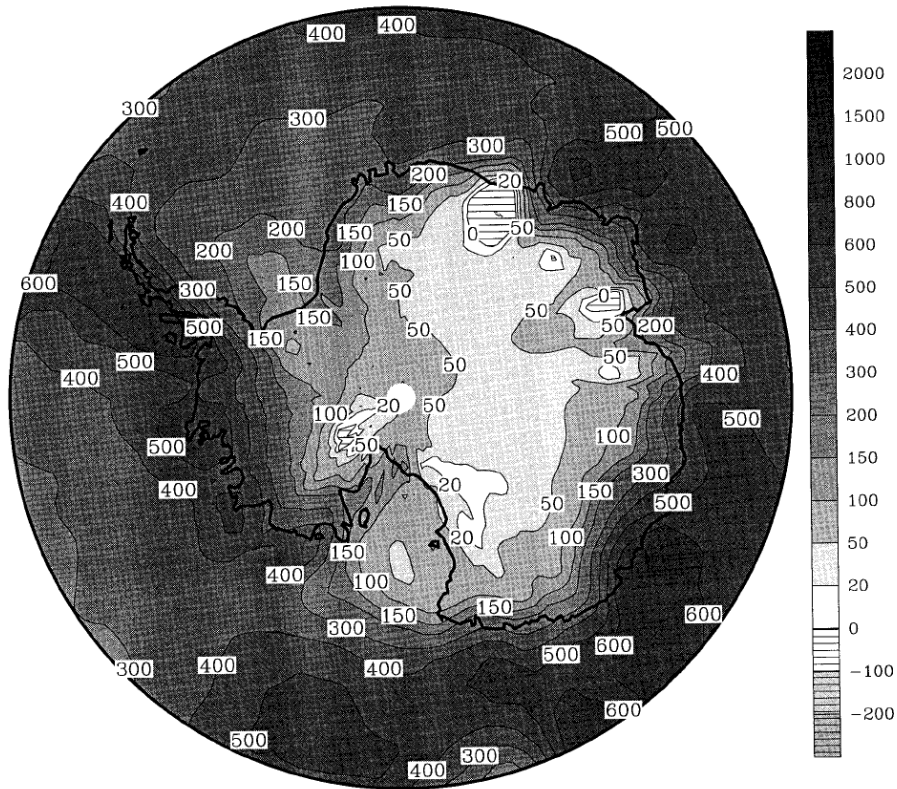
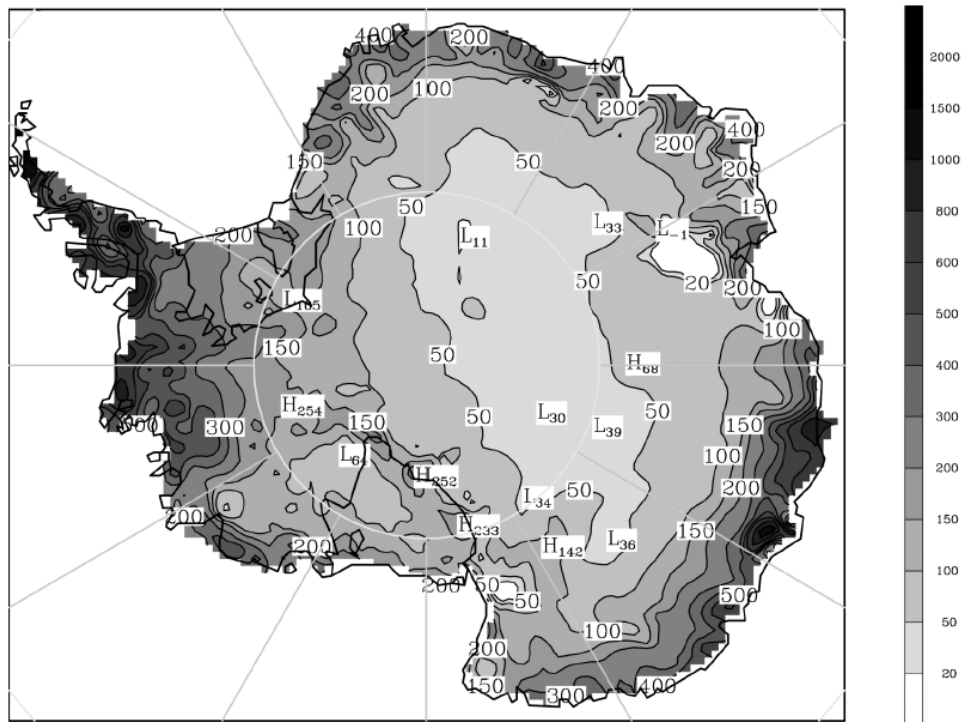
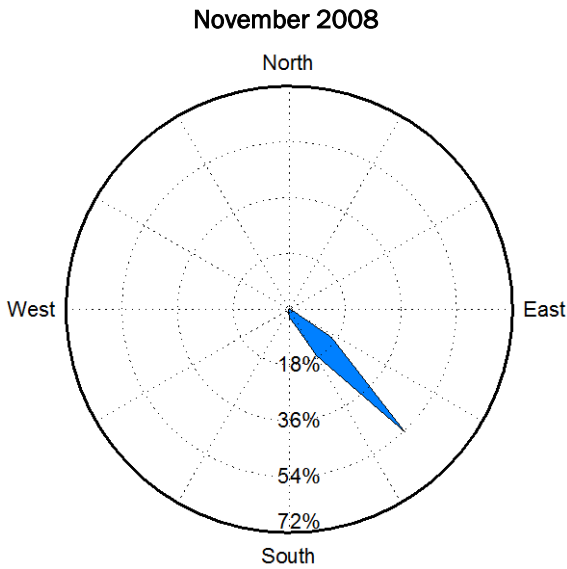
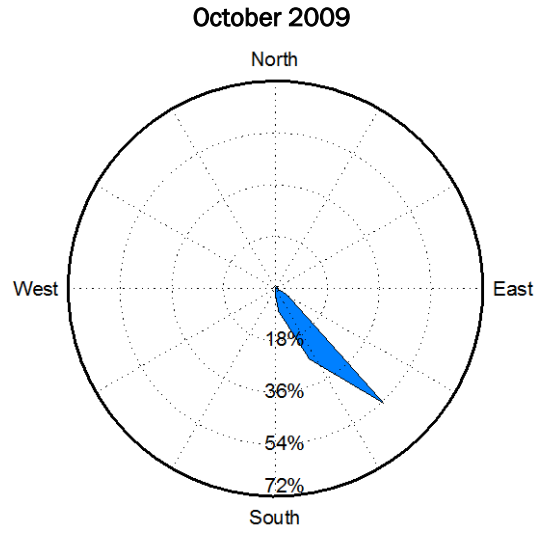
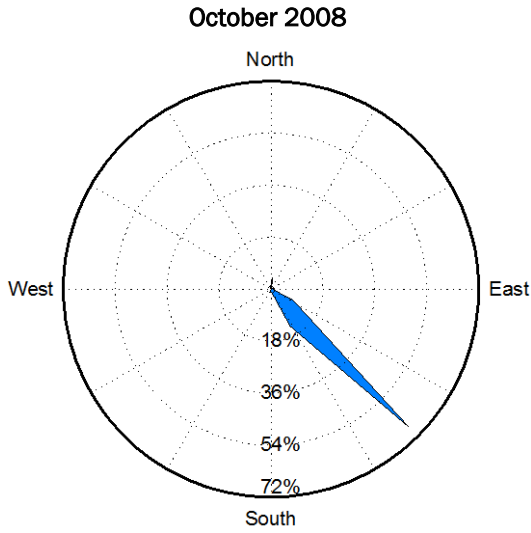

Figure A3. Annual P-E accumulation of S_{we} for the Antarctic continent (chart from Bromwich et al. 2004 based on data presented by Vaughan et al. 1999).



Appendix B: Summary of Wind Data at the Pine Island Glacier Camp



December 2008

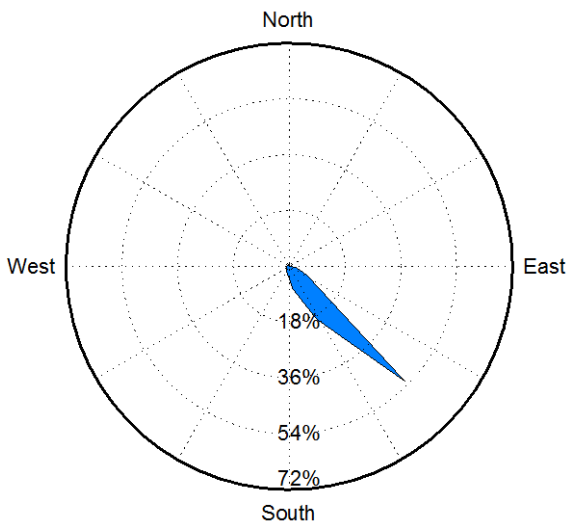

January 2009

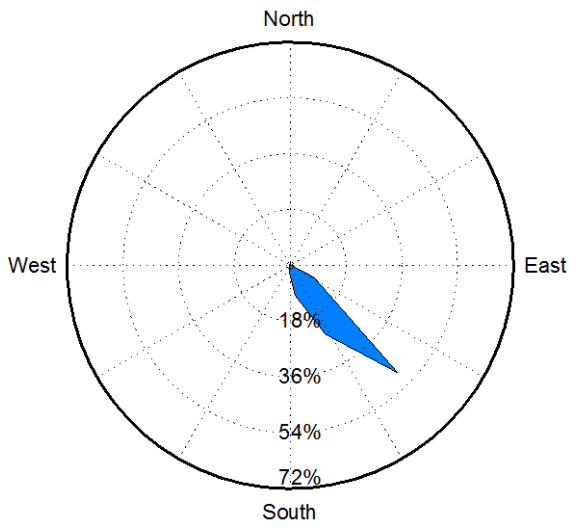

January 2011

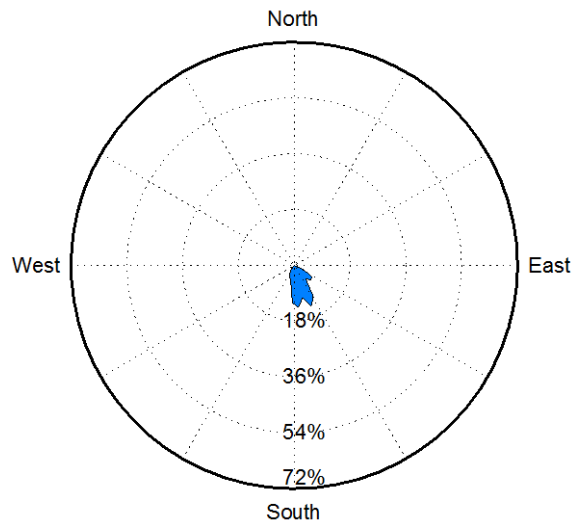

February 2009

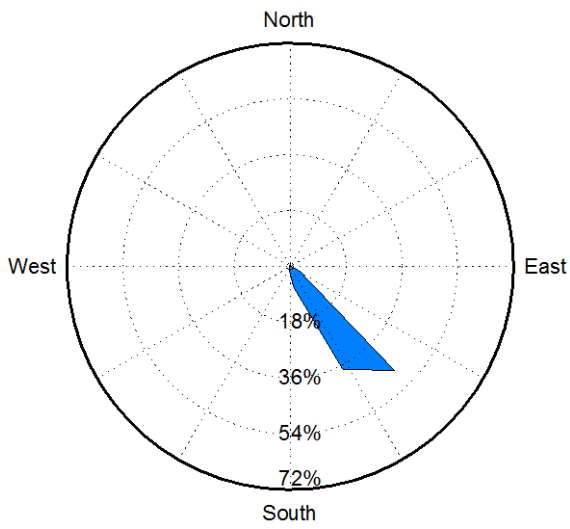

February 2011

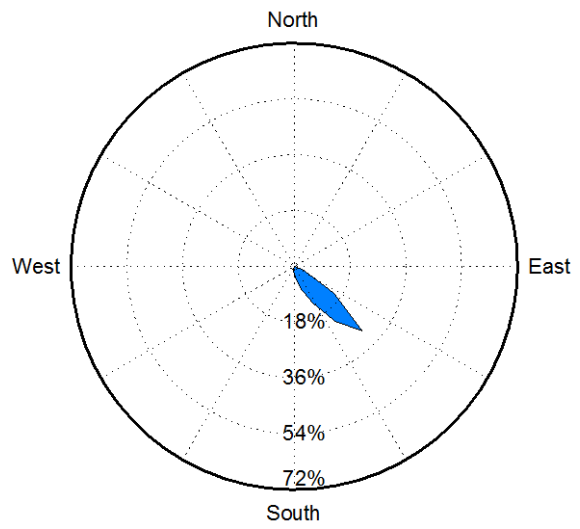

March 2009

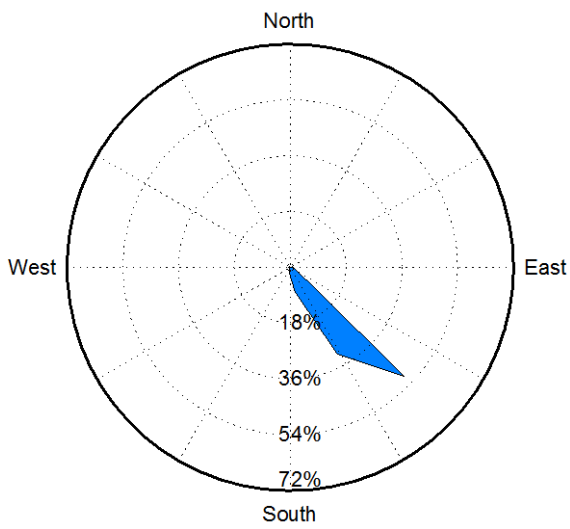

Appendix C: Summary of Estimated Transport Data at the Pine Island Glacier Camp

We obtained this estimate by using the wind data (summarized in Appendix B) to compute the snow transport using equation (1).

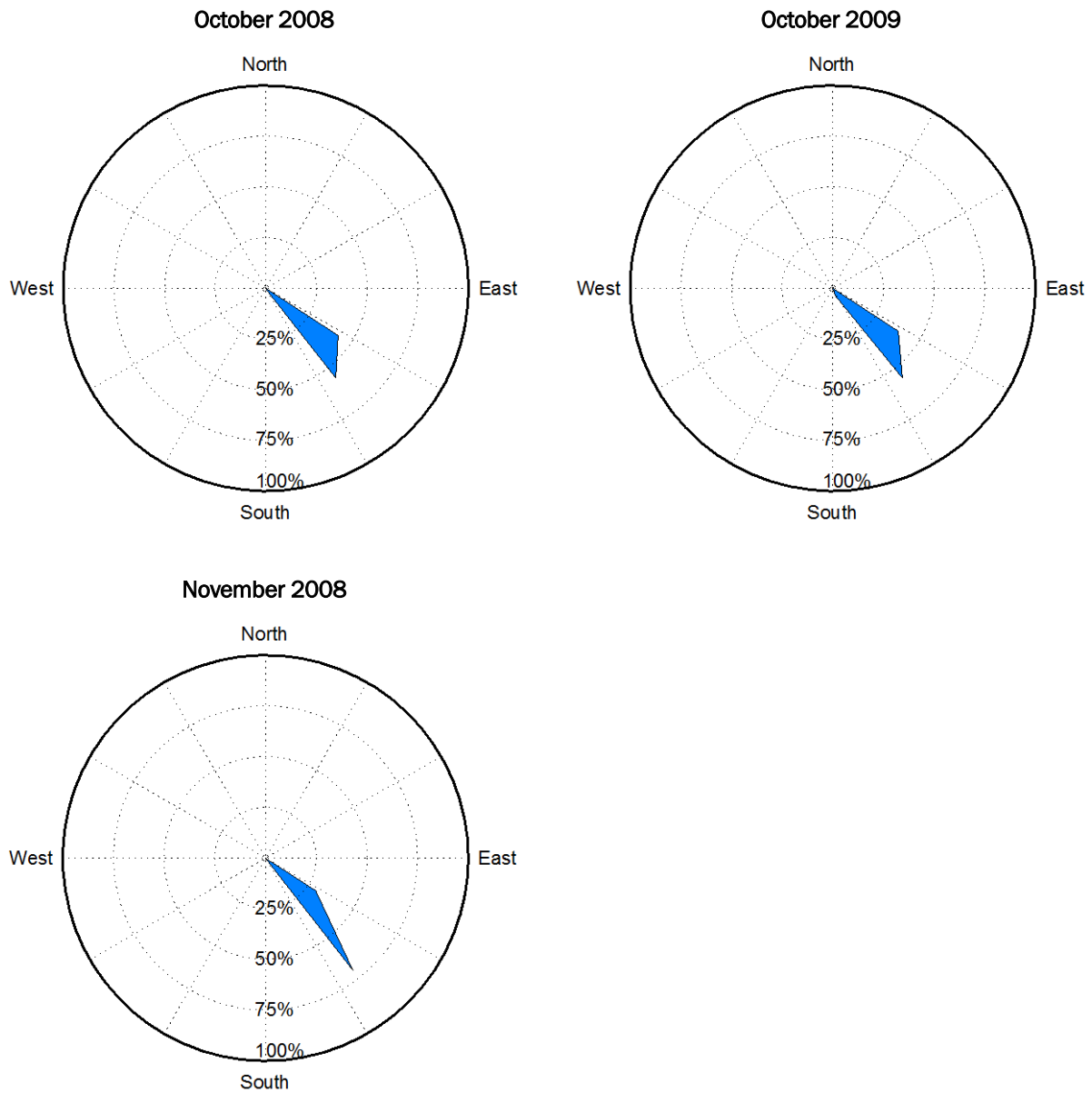

December 2008

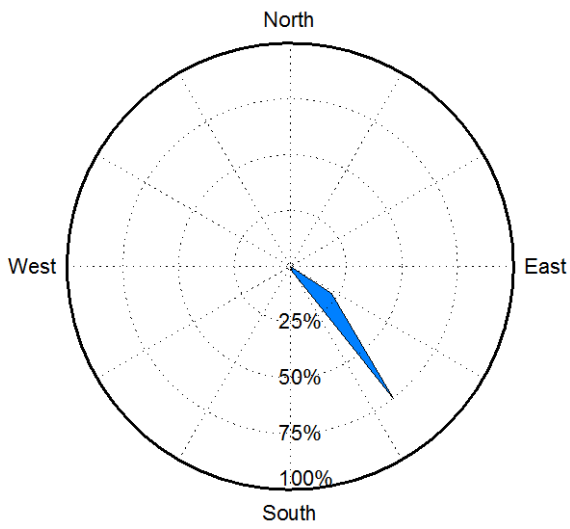

January 2009

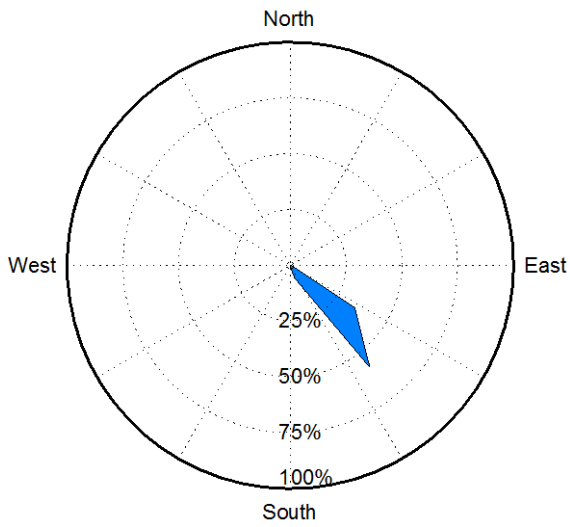

January 2011

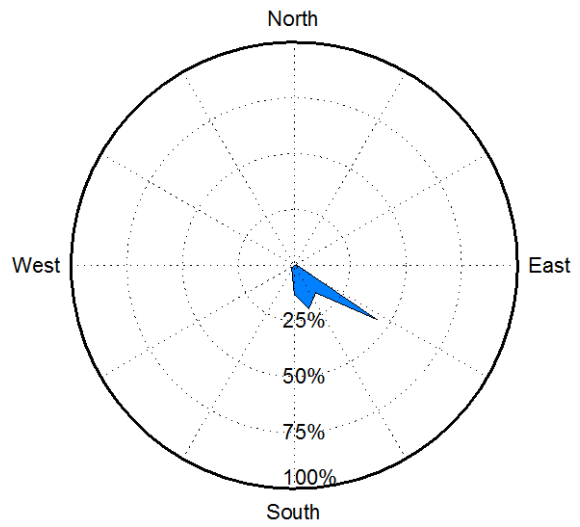

February 2009

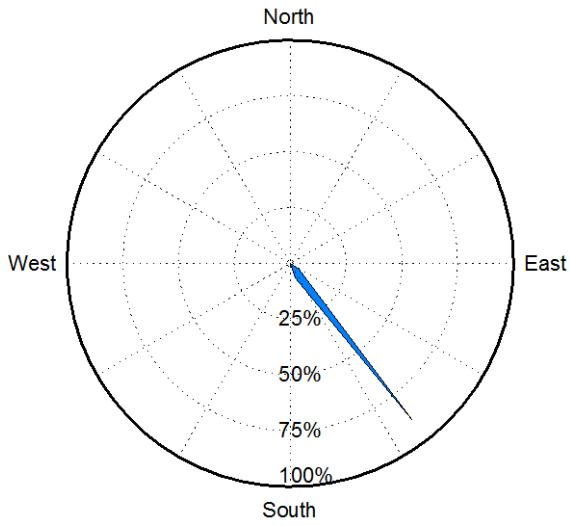

February 2011

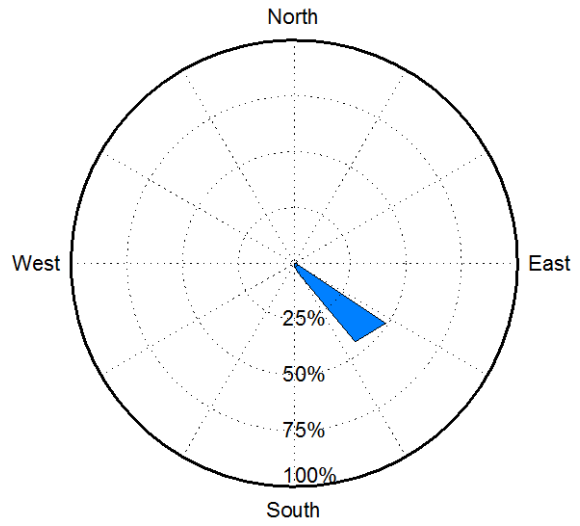

March 2009

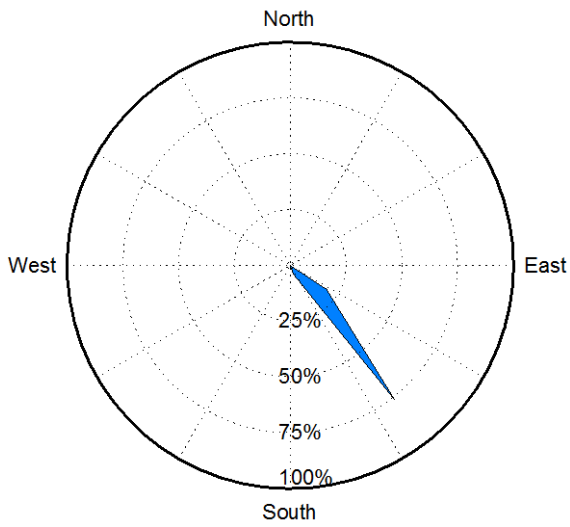

Appendix D: Satellite Image of the Region Surrounding the Pine Island Glacier Camp

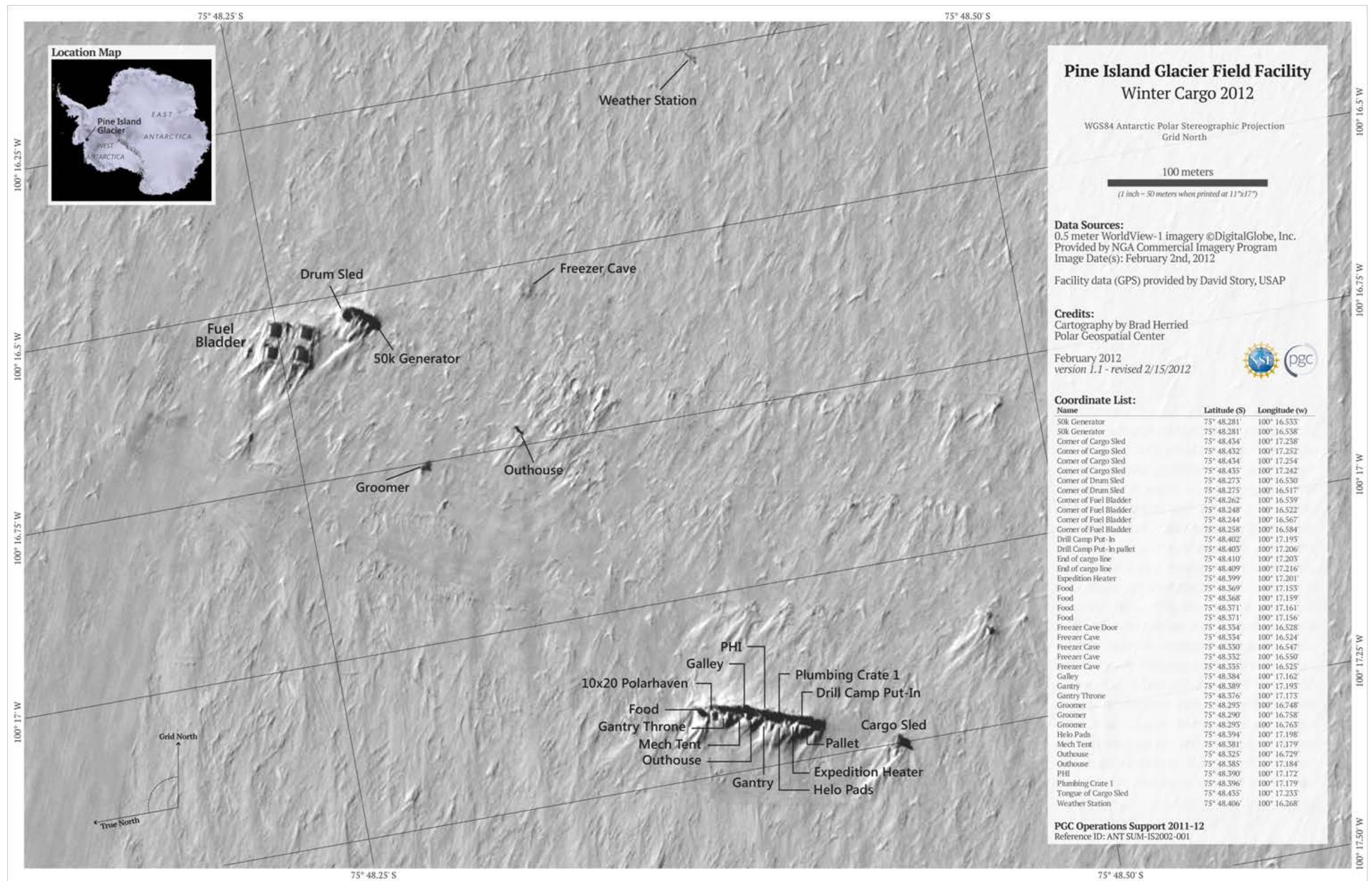

Appendix E: Pressure Force Tables

Table E1. Wind pressures, $P_{w,o}$, on snow fences that have porosity ratios of 0.5 ($C_d = 1.05$) at sea level and 20°C (68°F) as computed by numerical integration to determine the mean squared wind speed over fence height, H , taking $Z_o = 0.02$ cm. Z_f is height of resultant force, or moment arm (Tabler 1986).

H (m)	Z_f (m)	Wind Speed at 10 m (km/h)										
		100	110	120	130	140	150	160	170	180	190	200
		Wind Pressure, $P_{w,o}$ (Pa)										
1.0	0.56	240	290	345	405	470	539	614	693	776	865	959
1.2	0.67	251	304	362	425	492	565	643	726	814	907	1005
1.4	0.79	261	316	376	441	512	588	669	755	846	943	1045
1.6	0.90	270	327	389	456	529	607	691	780	875	975	1080
1.8	1.01	278	336	400	470	545	625	711	803	900	1003	1111
2.0	1.12	285	345	410	482	559	641	730	824	923	1029	1140
2.2	1.23	292	353	420	493	571	656	746	843	945	1053	1166
2.4	1.34	298	360	429	503	583	670	762	860	964	1074	1190
2.6	1.45	303	367	437	512	594	682	776	876	982	1095	1213
2.8	1.56	308	373	444	521	605	694	790	891	999	1114	1234
3.0	1.67	313	379	451	530	614	705	802	906	1015	1131	1254
3.2	1.76	318	385	458	537	623	716	814	919	1030	1148	1272
3.4	1.87	322	390	464	545	632	725	825	932	1045	1164	1290
3.6	1.98	327	395	470	552	640	735	836	944	1058	1179	1306
3.8	2.09	331	400	476	559	648	744	846	955	1071	1193	1322
4.0	2.20	334	405	481	565	655	752	856	966	1083	1207	1337
4.2	2.31	338	409	487	571	662	760	865	977	1095	1220	1352
4.4	2.41	341	413	492	577	669	768	874	987	1106	1233	1366
4.6	2.52	345	417	496	583	676	776	883	996	1117	1245	1379
4.8	2.63	348	421	501	588	682	783	891	1006	1127	1256	1392
5.0	2.74	351	425	506	593	688	790	899	1015	1138	1267	1404

Table E2. Correction factors C_{ET} for adjusting wind pressures in Table E1 for different elevations and temperatures, using equation (20). Example: To determine the wind load at 2200 m and -10°C , multiply value in Table E1 by 0.85 (Tabler 1986).

Elevation (m)	Air Temperature ($^{\circ}\text{C}$)						
	-40	-30	-20	-10	0	+10	+20
0	1.26	1.21	1.16	1.11	1.07	1.04	1.00
200	1.23	1.18	1.13	1.09	1.05	1.01	0.98
400	1.20	1.15	1.10	1.06	1.02	0.99	0.95
600	1.17	1.12	1.08	1.04	1.00	0.96	0.93
800	1.14	1.10	1.05	1.01	0.98	0.94	0.91
1000	1.12	1.07	1.03	0.99	0.95	0.92	0.89
1200	1.09	1.04	1.00	0.96	0.93	0.90	0.87
1400	1.06	1.02	0.98	0.94	0.91	0.87	0.84
1600	1.04	0.99	0.95	0.92	0.88	0.85	0.82
1800	1.01	0.97	0.93	0.90	0.86	0.83	0.80
2000	0.99	0.95	0.91	0.87	0.84	0.81	0.78
2200	0.96	0.92	0.89	0.85	0.82	0.79	0.77
2400	0.94	0.90	0.86	0.83	0.80	0.77	0.75
2600	0.92	0.88	0.84	0.81	0.78	0.75	0.73
2800	0.89	0.86	0.82	0.79	0.76	0.73	0.71
3000	0.87	0.83	0.80	0.77	0.74	0.72	0.69

Appendix F: Standard Wyoming Truss Fence Design

Figure F1. Generic plan for the Wyoming truss style snow fence (Tabler 1994). The dimensions are given in Table F1. Note that in detail A, rebar will not provide an adequate anchor in snow; and alternate anchoring methods must be employed (e.g., Section 5.2.3 of the main report).

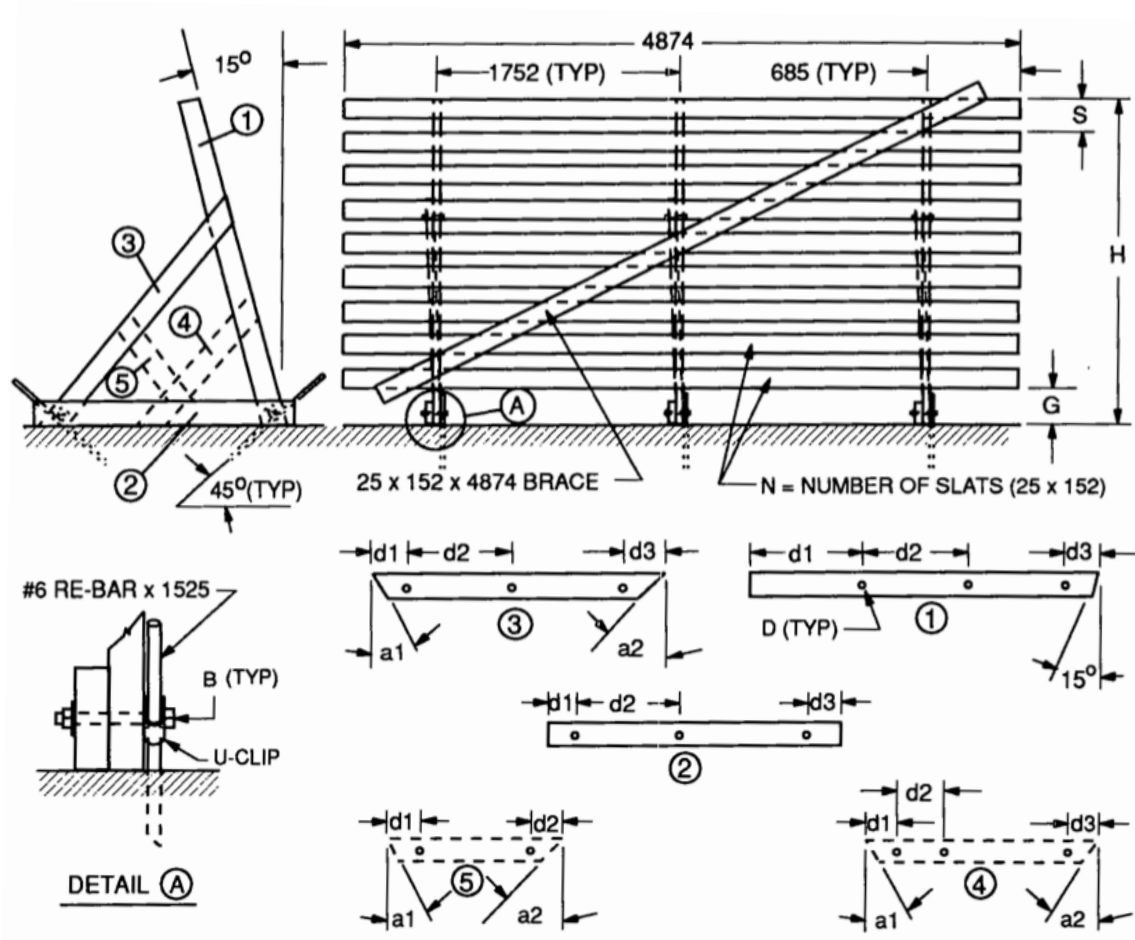

Table F1. Dimensions (mm) of structural members of the Wyoming snow fence shown in Figure 23. *S* and *G* dimensions are parallel to front vertical truss member. Lumber size for all truss members is 50 × 150 mm, except 50 × 200 mm is used for the long brace (Member Number 3) for the 4.3 m height.

Member I.D.	Description	Dimension I.D.	Dimension for Nominal Fence Height (m):				
			1.8	2.4	3.0	3.7	4.3
General	Vertical height	H	1766	2355	2944	3533	4122
	Slat spacing	S	279	279	279	279	279
	Number of slats	N	6	8	10	12	14
	Bottom gap	G	279	330	381	432	483
	Hole diameter	D	14	14	14	17	17
	Bolt diameter	B	13	13	13	16	16
1	Front vertical	Length	1829	2438	3048	3658	4267
		d1	610	819	819	792	1089
		d2	na	na	na	1518	1832
		d3	76	95	95	95	95
2	Sill	Length	1372	1524	2134	2438	2438
		d1	152	152	152	152	152
		d2	na	na	na	883	933
		d3	102	127	127	127	101
3	Long brace	Length	1676	2007	2743	3353	3658
		d1	152	140	140	137	133
		d2	na	na	na	1340	1162
		d3	152	165	171	186	241
		a1	32°	32°	32°	29°	25°
		a2	43°	43°	43°	47°	50°
4	Short brace	Length	NR	NR	NR	1829	1829
		d1	na	na	na	152	152
		d2	na	na	na	152	203
		d3	na	na	na	248	152
		a1	na	na	na	38°	38°
		a2	na	na	na	38°	38°
5	Knee brace	Length	NR	NR	NR	1372	1372
		d1	na	na	NR	152	152
		d2	na	na	NR	159	152
		a1	na	na	NR	39°	32°
		a2	na	na	NR	23°	32°

Bolt length at anchor attachments = 150 mm; all others = 125 mm.

NR = not required

na = not applicable

REPORT DOCUMENTATION PAGE

Form Approved
OMB No. 0704-0188

Public reporting burden for this collection of information is estimated to average 1 hour per response, including the time for reviewing instructions, searching existing data sources, gathering and maintaining the data needed, and completing and reviewing this collection of information. Send comments regarding this burden estimate or any other aspect of this collection of information, including suggestions for reducing this burden to Department of Defense, Washington Headquarters Services, Directorate for Information Operations and Reports (0704-0188), 1215 Jefferson Davis Highway, Suite 1204, Arlington, VA 22202-4302. Respondents should be aware that notwithstanding any other provision of law, no person shall be subject to any penalty for failing to comply with a collection of information if it does not display a currently valid OMB control number. PLEASE DO NOT RETURN YOUR FORM TO THE ABOVE ADDRESS.

1. REPORT DATE (DD-MM-YYYY) 29-09-2014			2. REPORT TYPE Final		3. DATES COVERED (From - To)	
4. TITLE AND SUBTITLE Antarctic Camps Snow Drift Management Handbook					5a. CONTRACT NUMBER	
					5b. GRANT NUMBER	
					5c. PROGRAM ELEMENT	
6. AUTHOR(S) Robert Haehnel and John Weatherly					5d. PROJECT NUMBER	
					5e. TASK NUMBER EP-ANT-12-11	
					5f. WORK UNIT NUMBER	
7. PERFORMING ORGANIZATION NAME(S) AND ADDRESS(ES) Cold Regions Research and Engineering Laboratory (CRREL) U.S. Army Engineer Research and Development Center (ERDC) 72 Lyme Road, Hanover, NH 03755-1290					8. PERFORMING ORGANIZATION REPORT NUMBER ERDC/CRREL TR-14-21	
9. SPONSORING / MONITORING AGENCY NAME(S) AND ADDRESS(ES) National Science Foundation 4201 Wilson Boulevard Arlington, VA 22230					10. SPONSOR/MONITOR'S ACRONYM(S) NSF	
					11. SPONSOR/MONITOR'S REPORT NUMBER(S)	
12. DISTRIBUTION / AVAILABILITY STATEMENT Approved for public release; distribution is unlimited.						
13. SUPPLEMENTARY NOTES Engineering for Polar Operations, Logistics, and Research (EPOLAR)						
14. ABSTRACT <p>Drifting snow on buildings, equipment, and tents at research camps throughout the Antarctic continent is a persistent problem. In this handbook, we provide methods to estimate the severity of the drifting problem at a proposed or an existing camp location and methods to ameliorate the drifting problems.</p> <p>The guidelines provided apply to camps where the wind is predominately from one direction, typical of a large percentage of the Antarctic continent where katabatic or down slope winds are dominant. The snowdrift protection methods outlined in this handbook do not suit regions where the storm winds can come from several dominant directions.</p> <p>Also included is a case study to demonstrate application of the methods outlined for estimating the severity of the drifting problem and for properly sizing the snowdrift protection system. Additionally, it provides methods to estimate the volume of snow that can be deposited during a camp season and gives examples of how to estimate the level of effort required to install the protection systems and to manage the snow throughout the camp season.</p>						
15. SUBJECT TERMS Berms, camps, EPOLAR, management, polar, shelters, snowdrift, snow fences						
16. SECURITY CLASSIFICATION OF:			17. LIMITATION OF ABSTRACT SAR	18. NUMBER OF PAGES 108	19a. NAME OF RESPONSIBLE PERSON	
a. REPORT Unclassified	b. ABSTRACT Unclassified	c. THIS PAGE Unclassified			19b. TELEPHONE NUMBER (include area code)	