

UNCLASSIFIED

NAVAL AIR WARFARE CENTER AIRCRAFT DIVISION
PATUXENT RIVER, MARYLAND



TECHNICAL INFORMATION MEMORANDUM

REPORT NO: NAWCADPAX/TIM-2014/43

A METHOD TO ESTIMATE FABRIC PARTICLE PENETRATION PERFORMANCE

by

Mr. Terence A. Ghee
Dr. Suresh Dhaniyala

8 September 2014

Approved for public release; distribution is unlimited.

UNCLASSIFIED

DEPARTMENT OF THE NAVY
NAVAL AIR WARFARE CENTER AIRCRAFT DIVISION
PATUXENT RIVER, MARYLAND

NAWCADPAX/TIM-2014/43
8 September 2014

A METHOD TO ESTIMATE FABRIC PARTICLE PENETRATION PERFORMANCE

by

Mr. Terence A. Ghee
Dr. Suresh Dhaniyala

RELEASED BY:

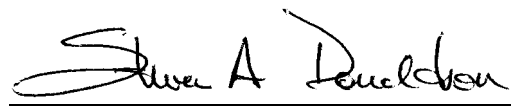
 8 Sep 2014

STEVE DONALDSON / AIR-4.3.2 / DATE
Head, Aeromechanics Division
Naval Air Warfare Center Aircraft Division

REPORT DOCUMENTATION PAGE			Form Approved OMB No. 0704-0188		
Public reporting burden for this collection of information is estimated to average 1 hour per response, including the time for reviewing instructions, searching existing data sources, gathering and maintaining the data needed, and completing and reviewing this collection of information. Send comments regarding this burden estimate or any other aspect of this collection of information, including suggestions for reducing this burden, to Department of Defense, Washington Headquarters Services, Directorate for Information Operations and Reports (0704-0188), 1215 Jefferson Davis Highway, Suite 1204, Arlington, VA 22202-4302. Respondents should be aware that notwithstanding any other provision of law, no person shall be subject to any penalty for failing to comply with a collection of information if it does not display a currently valid OMB control number. PLEASE DO NOT RETURN YOUR FORM TO THE ABOVE ADDRESS.					
1. REPORT DATE 8 September 2014	2. REPORT TYPE Technical Information Memorandum		3. DATES COVERED March 2004 – March 2014		
4. TITLE AND SUBTITLE A Method to Estimate Fabric Particle Penetration Performance			5a. CONTRACT NUMBER		
			5b. GRANT NUMBER		
			5c. PROGRAM ELEMENT NUMBER		
6. AUTHOR(S) Mr. Terence A. Ghee Dr. Suresh Dhaniyala			5d. PROJECT NUMBER		
			5e. TASK NUMBER		
			5f. WORK UNIT NUMBER		
7. PERFORMING ORGANIZATION NAME(S) AND ADDRESS(ES) Naval Air Warfare Center Aircraft Division 22347 Cedar Point Road, Patuxent River, Maryland 20670-1161			8. PERFORMING ORGANIZATION REPORT NUMBER NAWCADPAX/TIM-2014/43		
9. SPONSORING/MONITORING AGENCY NAME(S) AND ADDRESS(ES) Naval Air Systems Command Patuxent River, Maryland 20670-1547			10. SPONSOR/MONITOR'S ACRONYM(S)		
			11. SPONSOR/MONITOR'S REPORT NUMBER(S)		
12. DISTRIBUTION/AVAILABILITY STATEMENT Approved for public release; distribution is unlimited.					
13. SUPPLEMENTARY NOTES					
14. ABSTRACT A methodology was developed to predict fabric particle penetration performance for various wind speeds. Pressure drop across a fabric sleeve in a wind tunnel was measured along with the relationship of fabric pressure drop and fabric face velocity for a bench top swatch testing apparatus. The relationship between fabric face velocity and ambient wind speed was then inferred. Fabric penetration tests were conducted on four different configurations/materials using a wind tunnel component sleeve, a wind tunnel swatch (one material only), and a bench top swatch apparatus. Two challenges were utilized: DiOctyl Sebacate and Aerosol 380. The results were found to be consistent and repeatable. The methodology was successfully demonstrated using a wind tunnel swatch testing apparatus and comparison to bench top swatch results. Using this technique, tests are possible to compare, in an equivalent manner, material, fasteners, closures, and seam particle penetration performance subjected to an equivalent wind speed. Component sleeve particle penetration performance was compared to bench top swatch results and generally found to be within 0.2 (20%) for the DiOctyl Sebacate challenge. Aerosil challenge was found to generally differ by less than 0.1 (10%) between component sleeve wind tunnel tests and bench top swatch tests. While the methodology shows promise, further research of the particle dynamics in the vicinity of the sleeve and within the fabric/component gap may be needed to improve the correlation between wind tunnel component sleeve tests and bench top swatch test. The ability to predict multi-layered fabric performance from the constituent material performance was demonstrated and this technique may be useful in the design of tailored IPE systems.					
15. SUBJECT TERMS Estimate; Fabric; Particle; Penetration					
16. SECURITY CLASSIFICATION OF:			17. LIMITATION OF ABSTRACT	18. NUMBER OF PAGES	19a. NAME OF RESPONSIBLE PERSON
a. REPORT	b. ABSTRACT	c. THIS PAGE			Terence Ghee
Unclassified	Unclassified	Unclassified	SAR	70	19b. TELEPHONE NUMBER (include area code) (301) 342-8536

SUMMARY

A methodology was developed to predict fabric particle penetration performance for various wind speeds. Pressure drop across a fabric sleeve in a wind tunnel was measured along with the relationship of fabric pressure drop and fabric face velocity for a bench top swatch testing apparatus. The relationship between fabric face velocity and ambient wind speed was then inferred.

Fabric penetration tests were conducted on four different configurations/materials using a wind tunnel component sleeve, a wind tunnel swatch (one material only), and a bench top swatch apparatus. Two challenges were utilized: DiOctyl Sebacate and Aerosol 380. The results were found to be consistent and repeatable.

The methodology was successfully demonstrated using a wind tunnel swatch testing apparatus and comparison to bench top swatch results. Using this technique, tests are possible to compare, in an equivalent manner, material, fasteners, closures, and seam particle penetration performance subjected to an equivalent wind speed.

Component sleeve particle penetration performance was compared to bench top swatch results and generally found to be within 0.2 (20%) for the DiOctyl Sebacate challenge. Aerosil challenge was found to generally differ by less than 0.1 (10%) between component sleeve wind tunnel tests and bench top swatch tests. While the methodology shows promise, further research of the particle dynamics in the vicinity of the sleeve and within the fabric/component gap may be needed to improve the correlation between wind tunnel component sleeve tests and bench top swatch test.

The ability to predict multi-layered fabric performance from the constituent material performance was demonstrated and this technique may be useful in the design of tailored IPE systems.

Contents

	<u>Page No.</u>
Introduction.....	1
Experimental Apparatus.....	1
Wind Tunnel	1
Aerosil Challenge.....	2
Dissemination System.....	2
Component (Sleeve) Model	3
Swatch Holder Model	4
Bench Top Swatch Testing	4
Instrumentation	4
Material	5
Clarkson Bench Top Tests	6
Procedure and Data Reduction.....	6
Error Analysis	7
Data Repeatability.....	7
Results.....	8
Relationship between Fabric Face Velocity and Fabric Pressure Drop.....	8
Pressure Variation for the Component (Sleeve) Model.....	8
Particle Penetration	9
Control Checks.....	9
Repeatability of Results	9
Tie-In to Clarkson Bench Top Tests	10
Tie-In to Clarkson Component (Sleeve) Tests.....	10
Effect of Increasing Wind Velocity on Penetration.....	10
Comparison of Wind Tunnel and Bench Top Swatch Results	11
Fabric Penetration Comparison between Wind Tunnel Components.....	11
and Bench Top Swatch – DOS Challenge	
Fabrication Penetration Comparison between Wind Tunnel Component and.....	12
Bench Top Swatch – Aerosil Challenge	
Layering Effect on Fabric Penetration – Wind Tunnel Testing, DOS Challenge	12
Layering Effect on Fabric Penetration – Wind Tunnel Testing, Aerosil Challenge.....	12
Layering Effect on Fabric Penetration – Bench Top Testing, DOS Challenge	12
Layering Effect on Fabric Penetration – Bench Top Testing, Aerosil Challenge	13
Discussion.....	14

	<u>Page No.</u>
Conclusions.....	15
Recommendations.....	16
References.....	17
Appendices	
A. Figures.....	19
B. Tables.....	57
Distribution.....	61

ACKNOWLEDGEMENTS

The authors wish to thank the Office of Naval Research for providing funding for this work through the Naval Innovative Science and Engineering program (Section 219). In addition, we acknowledge the invaluable support of Mr. Kenneth Murphy, Mr. Rod Pursell, Ms. Wendy Todd, Mr. Jackson Shannon, and Mr. Christian Egbert.

NOMENCLATURE

A	Effective swatch area, 9.6 cm ²
b	Span length, 0.6096 m
D _p	Particle diameter, nm
N	Number concentration
P	Pressure, millibars
P _∞	Tunnel static pressure, millibars
ΔP	Static pressure difference, millibars
P	Fabric penetration, %
q _∞	Tunnel dynamic pressure, millibars
Q	Volumetric flow rate, Standard Liter Per Minute
R	Cylinder radius, 0.1143 m
ΔR	Fabric gap, 0.0159 m
U _o	Fabric face velocity, cm/s
V _∞	Tunnel freestream velocity, m/s
w	Permeability, cm/s
y	Spanwise location, m
α	Fabric permeability, m/s
ρ	Density, g/ml
μ	Gas constant, 1.7894 X 10 ⁻⁵ kg/(m)(s)
Θ	Azimuth Angle, degree
Ψ	Yaw Angle, degree

INTRODUCTION

Complete isolation from a chemically or biologically contaminated environment provides the best protection against percutaneous effects. This has been the goal of many individual protective equipment (IPE) designs; current ensembles intended to protect users against exposure to high chemical-biological (CB) agent concentrations (e.g., U.S. Marine Corps Chemical Biological Incident Response Force (CBIRF) Level A chemical protective overgarment (CPOG)) achieve this isolation by sealing users in a chemically impermeable garment. Heat stress becomes a major problem with this approach however, as normal physiological heat loss mechanisms (especially sweat evaporation) are blocked. Air-permeable materials with treated activated carbon were introduced to mitigate the heat stress problem without compromising CB protection.

The flowrate through air-permeable materials results from pressure differentials between the inside and outside of the garment. These pressure differentials are induced by body motions, e.g., the well-known “bellows effect”, as well as by wind. The wind can be the actual outdoor wind, an artificial wind created by helicopter downwash, or a relative wind created by riding on a moving vehicle.

Previous evidence, reference 1, suggested that maintaining IPE protection levels becomes a problem with elevated wind speeds (e.g., some swatch tests show up to 300X increases in IPE penetration with a 3X increase in wind speed). Generally, swatch, component, and system test results along with modeling trend in the same direction (elevated wind speed increases penetration) but did not uniformly indicate the problem is of the same order of magnitude.

Moreover, these results were controversial because much of the data is derived from test methodology that is largely unvalidated for assessing the effects of elevated wind speeds. For example, data obtained from the Aerosol/Vapor/Liquid Assessment Group (AVLAG) swatch test exceed the design parameters of the test cell (i.e., design nominal equivalent wind speed of 3.6 m/sec).

There is a limited understanding of system-level (full garment) high wind issues based on a lack of high wind speed penetration and deposition studies. In addition, the test technology is unvalidated. The present project was designed to investigate swatch and component tests in the presence of high winds (up to 36.6 m/s (120 ft/sec or 81.8 mph)). This paper describes the development of test methodology and results for component (sleeve) testing of fabric material in the wind tunnel at various component yaw angles.

EXPERIMENTAL APPARATUS

WIND TUNNEL

The tests were conducted in the Naval Aerodynamic Test Facility (NATF) wind tunnel located at Patuxent River, MD, reference 2 describes the NATF. The NATF is a 1.22 m by 1.22 m by 2.44 m long (4 ft by 4 ft by 8 ft long) closed test section, open-return wind tunnel, see Figures A-1 and A-2. The facility incorporates a 200 horsepower motor that drives a variable pitch, variable

RPM fan and delivers a maximum velocity of 60.96 m/s (205 ft/sec or 140 mph). In addition, the facility has honeycomb and three sets of flow conditioning screens that minimize free stream turbulence intensity to approximately 0.5% and free stream velocity differences to 1%.

AEROSIL CHALLENGE

In this study, two aerosol challenges were used: Aerosil 380 manufactured by Degussa (Frankfurt am Main, Germany) and DiOctyl Sebacate (DOS) manufactured by Sigma-Aldrich (St. Louis, MO). Aerosil 380 is a hydrophilic fumed silicate with a specific surface area of 380 m²/g. The average primary particle size is 7 nm, though the agglomerated size is much greater. Originally, the material was tagged with fluorescein in order to be used for deposition studies. Results showed little difference in penetration between tagged and untagged Aerosil: this report utilizes untagged Aerosil in the results.

DOS is a plasticizer that is liquid at room temperature and has a density of 0.914 g/mL.

Aerosil 380 challenge bulk density was measured using the ASTM D1895B method and included two controls: Arizona road dust and glass spheres see Table B-1.

DISSEMINATION SYSTEM

A dissemination system designed by Clarkson University personnel was modified and incorporated for the NATF. The system utilized an atomizing nozzle (Spray Systems, Co., Wheaton, IL, 1/4JAUMCO-316SS2050) that was installed in a 2.5-gal pressure tank (W.R. Brown Co., North Chicago, IL, Model Speedy). An earth-grounded, 5-gal pressure tank held a mixture of 200-proof ethanol and the aerosol challenge. The atomized spray was sent through a dryer/conditioner to a dissemination array placed in the wind tunnel test section (Figures A-3 and A-4). The dryer/conditioner consists of a capped, clear, 10.2 cm (4 in.) OD PVC pipe, within which a porous metal tube (Mott Corp., Farmington, CT, 1.9 cm (3/4 in. ID) was immersed in a bed of silica beads. The dryer/conditioner eliminated water vapor and most of the ethanol evidenced by a pre-drying peak centered at 50 nm. Post-dryer/conditioner, only the peak centered at 100 nm and associated with the aerosol challenge remained. As will be shown in subsequent sections, this arrangement was found to give temporally and spatially repeatable dissemination.

The Aerosil was successfully disseminated using a concentration of 0.1% by mass and suspended in 200-proof Ethanol. The dilution vents, shown in Figure A-3, were not needed for Aerosil dissemination. The final particle concentration was determined after trial and error. The initial concentration tried was 1% by weight. At such a high concentration the spray head was found to clog and temporal repeatability suffered. Early experimentation had reduced the concentration to 0.1% until clogging issues were minimized while still allowing an adequate particle count. Nevertheless, a regime of spray head cleaning had to be implemented to minimize test disruption. Frequent agitation using the fluid pressure tank agitator shown in Figure A-3 helped to insure consistency of the dissemination.

The DOS challenge was disseminated using the same system but with some slight modifications: a series of vents were placed between the dryer stage and the dissemination head to reduce the particle concentration to acceptable levels. Originally, the vents were filtered using Pall Corporation Model 12144 filters but as these became clogged over the course of testing without a ready replacement supply on hand, the filters were removed for the wind tunnel swatch testing. In addition, the dissemination tank pressure was reduced to 6 psi to reduce the amount of particle generation. Tank agitation was found to be unnecessary. The DOS concentration was 10% by volume suspended in 200-proof Ethanol.

The challenge was ejected in the wind tunnel via a series of ¼ in. tubing arranged in a square pattern and oriented facing forward to assist in mixing, see Figure A-5.

For bench top swatch testing, 0.1% Aerosil was mixed with distilled water. The water was removed from the particles using the desiccant dryer. DOS challenge was 10% by volume suspended in 200-proof Ethanol. A BGI, Inc. (Waltham, MA) 6-jet Collison Nebulizer was used to create the atomized particles, see Figure A-6.

COMPONENT (SLEEVE) MODEL

A component sleeve fixture was manufactured by Advanced Technologies, Inc. (ATI, Newport News, VA) to hold a simulated sleeve in the wind tunnel. The mounting hardware was built by the machine shop at Clarkson University. The 0.6096 m (2 ft) long component sleeve fixture consists of a 0.1143 m (4.5 in.) diameter cylindrical sleeve (with support screen) surrounding a solid inner cylinder (0.0826 m diameter, 3.25 in.), roughly the diameter of a human arm, with a 0.0159 m (0.625 in.) gap between sleeve and inner cylinder (the gap is 0.01429 m (0.5625 in. without support screen). A dummy upper mounting adaptor was installed to minimize flow angularity effects. As seen in Figure A-7a, a support screen was installed to prevent fabric flapping and deformation. A chordwise ring of 22 pressure taps were located 15.88 mm (5/8 in.) above the mid-point of the inner core of the model. Six pressure taps, spanning 0.3048 m (1 ft), were located at zero degrees to the wind to monitor two-dimensional flow. To measure the pressure drop across the fabric of the constrained sleeve (Figure A-7b), two pressure tubes were mounted normal to the fabric and were located just inside and outside of the sleeve. The pressure drop across the fabric was used to correlate local face velocities for varying ambient wind conditions on the fabric cylinder. Testing on an unconstrained sleeve, Figure A-7c, required gluing the 15.88 mm (0.625 in.) pressure tubes to the fabric (Note: particle penetration measurements were not acquired for the unconstrained sleeve). The pressure probes were located approximately 15.88 mm (0.625 in.) above the chordwise pressure ring. In order to acquire particle penetration data, a 3.175 mm (1/8 in.) diameter sampling probe was affixed to the inner core of the cylinder, see Figure A-8. This probe stood proud from the surface by approximately 6.35 mm (1/4 in.). An upstream sampling probe was located approximately 76 mm (3 in.) upstream and slightly below the downstream sampling probe.

SWATCH HOLDER MODEL

In order to mimic a swatch testing system used at RTI (RTI, International, Research Triangle Park, NC) that utilized a pressure drop across the swatch but no wind effect, see reference 3, a special fixture needed to be developed for wind tunnel use. The RTI apparatus was based on an ASTM Standard (F1215-89) for determining the filtering efficiency of flat-sheet filter media and subjects the swatch to a constant face velocity via a pressure drop across the material. The NAVAIR apparatus was designed to provide equivalent face velocities of the RTI tests of reference 3 while subjecting the swatch material to an external wind velocity. A tube with a sealed end allowed for a vacuum to be accurately and repeatedly applied to the swatch and create a repeatable face velocity regardless of freestream wind velocity, see Figure A-9. The length of the tube was designed to mitigate the effect of the bluff body shedding on the rear of the holder on the fabric penetration. A schematic of the swatch holder is shown in Figure A-10. The face velocity, U_o , is defined as:

$$U_o = \frac{Q}{A} \text{ (cm/s)} \quad (1)$$

Where Q is the volumetric flow rate through the swatch and A is the cross-sectional area of the swatch exposed to the airstream⁴.

The swatch holder incorporated a 0.32 cm (1/8 in.) sampling tube located 2.54 cm (1 in. downstream of the swatch (inside the holder). The inner diameter of the swatch holder was 9.53 cm (3.75 in.). Note, the area of the fabric was 72.97 cm² (0.785 ft²). A 15.24 cm (6 in.) diameter specimen was attached to the swatch holder via an automotive hose clamp. A 0.32 cm (1/8 in.) inner diameter sampling probe was also placed approximately 3.2 cm (1.25 in.) upstream (and in-line with the downstream probe) of the swatch, see Figure A-11. Swatch permeability was determined at 1.27 cm (0.5 in.) of water pressure drop between a static pressure ring internal in the swatch holder and a static port on the upstream side of the swatch, reference 5.

BENCH TOP SWATCH TESTING

In order to determine the fabric face velocity variation with fabric pressure drop (and also to test basic fabric particle penetration characteristics), a bench top swatch testing apparatus was designed and built using a Pall Corporation 47 mm filter holder to test the fabric specimen. The results of the testing were utilized to correlate fabric face velocity and wind tunnel speed.

Details of the bench top apparatus may be found in references 6 and 7.

INSTRUMENTATION

A TSI (TSI, Inc., St. Paul, MN) Model 3936 Scanning Mobility Particle Sizer (SMPS) was used to acquire particle count, size, and concentration data for sub-micron particles. This unit is composed of a TSI Model 3080 Electrostatic Classifier (with a long differential mobility analyzer (LDMA)) and a TSI Model 3025A Ultrafine Condensation Particle Counter (UCPC). A

0.0457 cm impactor nozzle was used with an aerosol flow rate of 0.3 liters/minute (lpm) and a sheath flow rate of 3.0 lpm to insure a 1-to-10 ratio as recommended by the manufacturer. Larger particles were measured using a TSI Model 3320 Aerodynamic Particle Sizer (APS). The APS had a sheath flow rate of 4.0 lpm and an aerosol flow of 1.0 lpm. The various instrument settings are provided in Appendix B-2. The APS was not used to measure the Aerosil challenge because the density of the Aerosil was too small for the instrumentation.

A Sierra Instruments, Inc. (Monterey, CA) Model C100M Mass Flow Controller was used to control the mass flow rate from a shop air source in order to provide make up air. The additional air flow was controlled such that the total flow (SMPS flow, APS flow, and make-up air) provided the correct the necessary sampling flow rate for each instrument.

Figure A-12 shows a schematic of the instrumentation set up and an image of the instrumentation is seen in Figure A-13 for the component model.

Figures A-14 to A-16 show a schematic of the instrumentation set up and an image of the instrumentation is seen in Figure A-17 for the wind tunnel swatch model. In order to match the required flow rate vacuum pumps or make-up air were added as needed. The amount depended on the flow conditions, material tested, and the instrumentation used (e.g., the Aerodynamic Particle Sizer drew 5 liters-per-minute and required make-up air for low wind tunnel speeds, see Figure A-15).

Basic fabric characteristics were determined via a bench top swatch testing system prior to wind tunnel testing. Bench top pressure differential data between the upstream and downstream of a 47mm swatch was measured using a digital pressure gage (Mensor Corp. San Marcos, TX, Model 2101) and provided a correlation between wind tunnel sleeve and bench top swatch pressure drop as determined from a technique developed by NAVAIR and reported in reference 6. A mass flow controller was used to determine permeability and fabric face velocity variation with differential pressure. A picture of the bench top swatch testing setup is shown in Figure A-18 and a schematic of the setup is shown in Figure A-19. Reference 7 describes the bench top set up in greater detail.

Component (sleeve) pressure was measured by a 10-in.-of-water and a 20-in.-of-water electronically-scanned-pressure module connected to a Pressure Systems, Inc. (now Measurement Specialties, Inc.) Inition pressure data acquisition system.

MATERIAL

The primary material used in the report was a 2/1 right-hand, 100% cotton twill (denim) weighing 10 oz per square yard purchased from JoAnn Fabrics on 21 May 2010. This material will be referred to as “10 Oz. Denim” in the report. The 10 Oz. Denim was tested for both challenges and for bench top and for the wind tunnel sleeve testing. The 10 Oz. Denim was also tested using the wind tunnel swatch model and DOS challenge. Other sleeves tested were Kimberly-Clark Corp. Kleenguard A30 Breathable Coveralls and a representative fabric used in

reference 6 to tie-in to previous testing. The material was sewn in-house to form a sleeve that fit snugly over the Component Model.

Additional bench top material tested: two commercial filter bags manufactured by Donaldson Company, Inc. (Dura-Life and Tetratex (PTFE)), and a commercial cotton twill fabric obtained from JoAnn Fabrics.

CLARKSON BENCH TOP TESTS

Bench top permeation tests were carried out in 2007 by personnel of the Mechanical Engineering Department at Clarkson University and reported in reference 6. A schematic of the experimental set up is shown in Figure A-20 and utilized a 47 mm filter holder. An image of the setup is shown in Figure A-21. The fabric material used in reference 6 was from the same lot as used in the NAVAIR bench top experiments tested in 2013.

PROCEDURE AND DATA REDUCTION

The NATF tunnel was allowed to thermally stabilize for over ½ hr before data acquisition commenced. Temperature was constant for a given tunnel speed, generally, 26.1°C at 36.6 m/s (79°F at 120 ft/sec). Isolated measurements of tunnel relative humidity were found to be 35%. After tunnel stabilization, pressure measurements were acquired for wind tunnel velocities of approximately 3 m/s, 6 m/s, 9 m/s, 14 m/s, 18 m/s, 27 m/s, and 36 m/s. Repeat points were conducted at 3 m/s and 36 m/s. Post-test, the data was converted to pressure coefficient:

$$C_p = \frac{P - P_\infty}{q_\infty} \quad (2)$$

For particle penetration tests, sequential scans of particle sampling were conducted after tunnel thermal stabilization. The sequential scans proceeded with the freestream sampling probe (upstream of the model) followed by the downstream of the fabric sampling probe. A total of 120 sec of data was taken for each scan for five downstream/upstream pairs. SMPS resolution was acquired at 64 channels per decade. For analysis the data was resolved to 16 channels per decade. Simultaneously, the APS acquired summation-mode data. Particle penetration was determined by dividing the average downstream sample (in units of $dN/d \log D_p$) by the average upstream sample (in units of $dN/d \log D_p$, where N is the number concentration of particles and D_p is the particle diameter size). The subsequent data were plotted as penetration⁴ versus particle size (nm).

$$P(D_p) = \frac{N_{down}}{N_{up}} \quad (3)$$

Where N_{down} is the number of particles downstream and N_{up} is the number of particles upstream of diameter D_p .

Note: $dN/d \log D_p$ is the differential or normalized particle size distribution based on particle number and normalized to one decade of particle size. This normalized concentration format allows particle size distributions to be compared regardless of channel resolution. In this way the present data is comparable to data taken at other facilities and with other instrumentation.

Comparison of the initial upstream/downstream particle count measurement with the final upstream/downstream particle count measurements was used to determine the existence of fabric loading due to particle deposition. If the last upstream/downstream sequence was significantly different from the initial upstream/downstream sequence in particle count, this would be a sign of fabric loading and would lead to erroneous penetration values. No data reported in this paper was affected by detrimental fabric loading due to particle deposition.

It should be noted that numerous background particle measurements were acquired throughout the course of testing: the data were consistently below 10 counts per channel in the SMPS (and in most cases much below this value) and negligible for measurements acquired by the APS at larger sizes. No long term change in these background levels was observed.

ERROR ANALYSIS

As mentioned previously, the empty tunnel velocity spatial uniformity is approximately 1%. At a given spatial location in the test section, the tunnel velocity varied by approximately 0.5%. Tunnel temperature variations were less than 0.2°F in test. Experimental uncertainty was determined in a method outlined in reference 8 and the measured velocity was estimated to be with in $\pm 1.45\%$. The pressure measurements, based on manufacturer's estimates, were accurate to $\pm 0.05\%$ full scale (after re-zero).

DATA REPEATABILITY

Because this method of testing sleeve component and bench top swatch material forms the basis in the development of a predictive tool to define fabric penetration performance, it was important to determine the robustness of the test set up and methodology. A number of repeat configuration tests and checks were conducted to assess the uncertainty of the entire system and will be discussed in the next section.

RESULTS

RELATIONSHIP BETWEEN FABRIC FACE VELOCITY AND FABRIC PRESSURE DROP

A linear relationship between face velocity and fabric pressure drop was seen for various fabrics and is shown in Figure A-22 for bench top fabric tests. This is a common result for most fabrics, c.f., reference 9. The permeability line on the figure is the average speed of the flow of air passing through the material at a short distance ahead or aft of the textile sheet. In the United States, this speed is determined for a pressure differential across the fabric face of $\Delta P = 0.5$ in. H₂O or 2.6 lb/ft², see reference 5. The average permeability, standard deviation, and number of samples are provided in Table B-3. The data plotted in Figure A-22 was normalized to the average values of permeability for the fabrics shown in Table B-3. The number of samples for the averages ranged from 14 to 26.

PRESSURE VARIATION FOR THE COMPONENT (SLEEVE) MODEL

Following bench top swatch tests, component sleeve fixture testing was conducted in the NATF. Wind tunnel velocity was varied to determine the pressure variation on the model. Figure A-23 compares the fabric pressure drop to the pressure difference measured on the inner cylinder at an azimuth angle of 0 deg. As seen in Figure A-23, there is little difference in these pressures particularly above ambient winds of 14 m/s for the case of the constrained sleeve. Differences below 14 m/s were likely due to the resolution of the pressure instrumentation (this testing utilized a 20 in. of H₂O ESP module because the 10 in. H₂O ESP module was unavailable) and in maintaining tunnel conditions.

However, for the case of the unconstrained sleeve, the fabric pressure drop was seen to be significantly lower than the pressure difference measured on the inner cylinder at an azimuth angle of 0 deg.

Reference 10 developed a potential flow model for the case of a constant gap (constrained sleeve) to determine the pressure drop across the fabric:

$$\Delta P = \frac{4\rho V_{\infty}^2 \cos 2\Theta}{\beta^2 + 4} \quad (4)$$

Where β^2 is:

$$\beta^2 = \frac{12\mu\alpha R^2}{\Delta R^2} \quad (5)$$

The pressure drop across the fabric at an azimuth angle of 0 deg is compared to potential theory in Figure A-23. The permeability for 10 Oz. Denim was used for the potential flow model but surprisingly permeability was found to have little effect on the potential flow. As seen in the figure the fabric pressure drop is 30% lower than the potential flow model prediction at highest

wind speed. Reference 6 noted improved correlation using a screen and material around the mounting fixture. However, the present test utilized a dummy mounting mechanism above the model to mimic the tunnel mounting hardware: it is doubted that asymmetrical differences in the flow field account for the differences seen between the potential model and test data of Figure A-23. Regardless, spanwise pressure coefficients were noted to be invariant signifying notional two-dimensional flow, see reference 9.

A correlation between fabric face velocity and wind tunnel speed is shown in Figure A-24 and was determined knowing the pressure drop across the constrained sleeve at an azimuth angle of 0 deg and using the linear relationship between face velocity and pressure drop determined from bench top testing and shown in Figure A-22. The curves exhibit an exponential increase in face velocity with increasing wind speed. The relationship shown in Figure A-24 is used to correlate bench top penetration testing to component and wind tunnel swatch (reference 7) testing using a common parameter; face velocity.

PARTICLE PENETRATION

CONTROL CHECKS

To gage the quality of the developed testing system, particle penetration tests were conducted on the component fixture devoid of a fabric sleeve but with the sleeve support screen (the configuration seen in Figure A-7a). As seen in Figure A-25, particle penetration was generally between 90% and 110% for both challenges. Figure A-26 presents the results of control checks (no fabric swatch) for the bench top swatch set up for both challenges. For the Aerosil challenge, a face velocity of 1.8 cm/s was the only face velocity tested. Particle penetration was generally between 90% and 110% for both challenges for the bench top apparatus.

REPEATABILITY OF RESULTS

Figure A-27 shows typical repeatability for a sleeve test in the wind tunnel with Aerosil and DOS challenge using the SMPS and APS. In general, DOS was easier to disseminate and caused less clogging than Aerosil which resulted in better repeatability.

Figure A-27a shows typical repeatability for the sleeve test in the wind tunnel with DOS challenge using the SMPS and APS. Repeatability was found to be less than 5% in particle penetration for DOS. Aerosil challenge repeatability is shown in Figure A-27b and found to be generally within 10% for fabric particle penetration.

Typical downstream and upstream data are shown in Figures A-28 to A-31 10 Oz. Denim for DOS and Aerosil challenges for component and bench top tests. The data was found to be repeatable and devoid of filter loading effects that would cause a variation in the downstream data over time for the tests.

TIE-IN TO CLARKSON BENCH TOP TESTS

As mentioned, Clarkson University personnel performed bench top swatch testing in 2007 using different instrumentation and software, mass flow controllers, and dissemination system. As a check on the robustness of the developed techniques and systems, bench top swatch tests using the same challenge and material were conducted in 2013. As shown in Figure A-32, excellent agreement was found between the two test results.

TIE-IN TO CLARKSON COMPONENT (SLEEVE) TESTS

Clarkson University personnel performed wind tunnel sleeve tests in 2007 using different SMPS instrumentation and software, mass flow controllers, and dissemination system, reference 6. As a check on the robustness of the developed techniques and systems, wind tunnel sleeve tests using the same challenge and material were conducted in 2013. As shown in Figure A-33, the comparison between the two data sets was not stellar. Above 9.1 m/s, the Clarkson data were found to have a lower maximum particle penetration compared to the NAVAIR data. The Clarkson test results had a maximum particle penetration greater than the NAVAIR data at 9.1 m/s.

In addition, the Clarkson data exhibited a decrease in maximum particle penetration at 36.6 m/s compared to the Clarkson data at 18.3 m/s.

Reference 6 measured particle penetration using different flow rates through the downstream sample probe and found no change in particle concentrations downstream of the fabric, suggesting that the instrument sample flow rates were significantly smaller than the ambient wind-driven flow flux. Therefore, any differences between NAVAIR and Clarkson instrumentation flow rates are unlikely to explain the differences seen in Figure A-33. However, the effect of the downstream sampling probe azimuthal location was reported to have an effect on downstream particle concentration, suggesting the air volume between the outer fabric cylinder and the inner cylinder is not well mixed. The tests of reference 6 chose a downstream sampling probe located between $\Theta_{\text{probe}} = \sim 30 \text{ deg} - 60 \text{ deg}$ based on the location that yielded the maximum particle penetration value. The NAVAIR sampling probe was located at a probe azimuth angle of $\Theta_{\text{probe}} = 0 \text{ deg}$ for a yaw angle of $\psi = 0 \text{ deg}$. This may explain the differences seen in Figure A-33. A difference in particle penetration with azimuth angle was also noted in reference 11.

EFFECT OF INCREASING WIND VELOCITY ON PENETRATION

Particle penetration measurements were determined for a yaw angle of 0 deg and are shown in Figure A-34. Increasing wind velocity was found to increase particle penetration through a 10 Oz. Denim sleeve test using a DOS challenge. This trend was noted for bench top and wind tunnel swatch and component models for both challenges, see references 7, 9, and 11. For sub-micron sizes where the peak particle penetration occurred, a general trend of increasing wind speed exhibited increased penetration. High sub-micron to micron-sized particles tended to increase in particle penetration with wind velocity until 9 m/s. Higher wind speeds tended to a

see a reduction in particle penetration. This phenomenon is explained by single fiber filter efficiency models, references 4 and 6.

As shown in Figures A-35 and 36, show the effect of the various filter mechanisms (i.e., impaction, interception, and diffusion) has on the total filter efficiency for a low and a high fabric face velocity. Impaction occurs when a particle is unable to follow a streamline around a fiber because of inertial effects and impacts the fiber. Interception occurs when a particle follows its streamline but that streamline is within one particle radius of a fiber. The particle hits the fiber and is captured. Diffusion transport occurs because of the effect of Brownian motion. Brownian motion is the irregular motion of a particle in still air caused by random variation of gas molecules against the particle, reference 4. The random motion greatly increases the probability of a particle striking a fiber and being capture. Very small particles not subjected to high face velocities are captured mainly by diffusion, see Figure A-35. As particle size increases, interception becomes the primary filtration mechanism (with impaction being slightly lesser in importance). As face velocity is increased, see Figure A-36, interception and impaction cause an increase in overall filter efficiency. Nearly all large particles are captured with the primary filtration mechanism being impaction.

COMPARISON OF WIND TUNNEL AND BENCH TOP SWATCH RESULTS

Figure 37 shows the results from bench top testing of the penetration performance of 10 Oz. Denim for a variety of face velocities. Generally, the peak penetration increased with increasing face velocity. An equivalent wind tunnel velocity, termed V_{eq} , was determined for each curve based upon the relationship shown in Figure A-24.

Wind tunnel swatch test results are compared to the bench top swatch test results and are shown in Figures A-38 through A-41. The bench top penetration curves were converted to the proper equivalent wind tunnel velocity by interpolation of the data in Figure A-37 using an Akima curve fit (reference 12). Generally, there is very good agreement between the data sets. It is noted there are slight discrepancies for the larger particle sizes: the wind tunnel swatch experiences higher penetration than the bench top swatch. However, the maximum penetration and the size at which the maximum penetration occurs were nearly identical between the wind tunnel swatch and bench top swatch results.

FABRIC PENETRATION COMPARISON BETWEEN WIND TUNNEL COMPONENT AND BENCH TOP SWATCH – DOS CHALLENGE

Figures A-42 through A-45 shows the comparison the comparison of the fabric particle penetration of the component sleeve to the interpolated bench top swatch data at the equivalent wind tunnel velocity using DOS challenge for four configurations: 10 Oz. Denim, the material used in reference 6, A30 coverall material, and an A30 sleeve over 10 Oz. Denim (A30+10 Oz. Denim). As a reminder, the equivalent wind tunnel velocity for the bench top data was calculated by interpolation of the data of Figure A-37 using an Akima curve fit (reference 12). While the component sleeve and bench top swatch data sets followed the same trends – increasing velocity increased particle penetration – the comparison generally was generally no worse than 0.2 (20%)

in particle penetration. Table B-4 depicts these differences more concisely. Five of the configurations fall within a difference-band from 0.1 to 0.2 (10% to 20%) and are considered to have marginal to acceptable agreement based on the test repeatability. Five configurations were under 0.1 (10% difference in particle penetration which is considered to have good agreement. Three configurations had difference above 0.2 and were considered to have very poor agreement.

FABRIC PENETRATION COMPARISON BETWEEN WIND TUNNEL COMPONENT AND BENCH TOP SWATCH – AEROSIL CHALLENGE

The comparisons using an Aerosil challenge were found to have much better agreement between the sleeve component and bench top swatch data, see Figures A-46 through A-49. Most configurations (12) were found to be in agreement within 0.1 (10%). Table B-5 depicts these differences more concisely.

LAYERING EFFECT ON FABRIC PENETRATION – WIND TUNNEL TESTING, DOS CHALLENGE

Figures A-50 through A-53 shows the comparison of layering two different materials (A30 and 10 Oz. Denim – the open red circles in the figures) to a prediction obtained from the individual material particle penetration values (solid red circle symbol on the figures) using DOS challenge in the wind tunnel. The predicted curve was obtained by multiplying the A30 particle penetration curve (black open square) by the corresponding 10 Oz. Denim particle penetration curve (blue open diamond).

The prediction was found to be within 0.05 (5%) in particle penetration for the lowest speed tested, 3.0 m/s, and within 0.1 (10%) in particle penetration for wind speeds of 9.1 m/s. At highest speed, the prediction was found to be above 0.1 (10%) in particle penetration while the difference was greater than 0.2 (20%) in particle penetration at a wind tunnel speed of 18.3 m/s.

LAYERING EFFECT ON FABRIC PENETRATION – WIND TUNNEL TESTING, AEROSIL CHALLENGE

Figures A-54 through A-57 shows the comparison of layering two different materials (A30 and 10 Oz. Denim – the open red circles in the figures) to a prediction obtained from the individual material particle penetration values (solid red circle symbol on the figures) using Aerosil challenge in the wind tunnel. In general, the Aerosil challenge data was seen to have a better prediction of the layering effect for wind tunnel sleeve tests. Table B-6 depicts the difference in tabular form.

LAYERING EFFECT ON FABRIC PENETRATION – BENCH TOP TESTING, DOS CHALLENGE

Figures A-58 through A-60 shows the comparison of layering two different materials (A30 and 10 Oz. Denim – the open red circles in the figures) to a prediction obtained from the individual material particle penetration values (solid red circle symbol on the figures) using DOS challenge

for bench top swatch tests. As a reminder, the equivalent wind tunnel velocity for the bench top data was calculated by interpolation of the data of Figure A-37 using an Akima curve fit (reference 12). The additive predictions were seen to be within 0.1 (10%) in particle penetration for all conditions tested.

LAYERING EFFECT ON FABRIC PENETRATION – BENCH TOP TESTING, AEROSIL CHALLENGE

Aerosil challenge was seen to provide a better prediction of the layering effect for bench top swatch tests compared to the DOS challenge data, see Figures A-61 to A-63. All predictions had less than 0.05 (5%) difference in particle penetration between the layered data and the prediction. Table B-7 depicts the differences between layered configurations and predictions in tabular form for the bench top tests.

DISCUSSION

Increasing the wind tunnel velocity was found to increase penetration for the component sleeve and wind tunnel swatch tests in a manner similar to increasing the face velocity for the bench top swatch test. This may seem intuitive and it may be thought that as long as the face velocity is the same as the bench top results then the penetration results would be equivalent to the wind tunnel results (as long as the wind tunnel velocity was not grossly different from the estimated face/wind tunnel velocity combination). This was found, inadvertently, to not be the case.

During the course of wind tunnel swatch testing at 6.1 m/s, the face velocity was set to a value that was equivalent for a wind tunnel speed of 3.0 m/s. As seen in Figure A-64, the penetration of particles through the material with the erroneous, lower face velocity for a wind speed 6.1 m/s did not match the penetration at same face velocity but at the lower 3.0 m/s wind speed. Thus, the external freestream velocity is an important factor in matching the penetration performance.

Correlating the wind tunnel swatch to a bench top swatch by using the pressure drop (and calculated face velocity) of the component sleeve at $\psi=0$ deg to set the face velocity of the wind tunnel swatch IPE fabric and components to be tested and compared on an equivalent basis (e.g., fasteners, closures, and seams may be tested and potentially improved using a variation of the wind tunnel swatch testing fixture or a modified bench top apparatus).

The present technique shows promise to predict particle performance: the general trend of a decrease in fabric pressure drop/fabric face velocity results in a decrease in particle penetration through the fabric and the results generally vary by less than 0.2 (20%) in fabric particle penetration between component sleeve in the wind tunnel and the bench top swatch test. In addition, the relative performance of different fabrics was found to be invariant whether using a sleeve component or bench top apparatus regardless of challenge. However, fabric pressure difference/fabric face velocity is not the sole parameter to identify particle penetration. There may be an aerodynamic/particle dynamic aspect that effect particle penetration and that is not being taken into account.

Differences between the pressure on the leeward side of the fabric (point A in the schematic in the figure) and the corresponding pressure tap on the model inner core (point B in the schematic in the figure) are shown in Figure A-65. Pressure differences were found to be small and invariant with azimuth. The minor difference in does not explain the penetration differences between component sleeve and bench top swatch results and warrants further investigation into the flow in the sleeve/component gap. Also unknown, and difficult to quantify, is the effect of the sleeve on the particle streamlines, and thus the penetration performance. It is suspected that this effect becomes a concern when fabric permeability is decreased. Further research could determine the effect of the sleeve on the flow using Particle Image Velocimetry.

The ability to predict the additive effect of layered materials may be an important design tool to match different material layers to tailor fabric penetration performance. The use of the bench top swatch apparatus can lead to acceleration of the design process.

CONCLUSIONS

A methodology was developed to predict fabric particle penetration performance for various wind speeds. Pressure drop across a fabric sleeve in a wind tunnel was measured along with the relationship of fabric pressure drop and fabric face velocity for a bench top swatch testing apparatus. The relationship between fabric face velocity and ambient wind speed was then inferred.

The methodology was successfully demonstrated using a wind tunnel swatch testing apparatus and comparison to bench top swatch results. Using this technique, tests are possible to compare, in an equivalent manner, material, fasteners, closures, and seam particle penetration performance subjected to an equivalent wind speed.

Component sleeve particle penetration performance was compared to bench top swatch results and generally found to be within 0.2 (20%) for the DOS challenge. Aerosil challenge was found to generally differ by less than 0.1 (10%) between component sleeve wind tunnel tests and bench top swatch tests. While the methodology shows promise, further research of the particle dynamics in the vicinity of the sleeve and within the fabric/component gap may be needed to improve the correlation between wind tunnel component sleeve tests and bench top swatch test.

The ability to predict multi-layered fabric performance from the constituent material performance was demonstrated and this technique may be useful in the design of tailored IPE systems.

RECOMMENDATIONS

The results from this test are part of an initial development of a component, or simulated sleeve, testing methodology. However, this work is still in its infancy and much work needs to be accomplished to understand the flow physics inside and outside the component, the dynamics of material flapping, bellow effect, the effect of closures and seams, and particle penetration and deposition.

Computational modeling should be developed in parallel with the experimental effort to aid in the design of new fielded systems. A simplified model of a full system could be modeled by using a number of component sleeves to represent various parts of the whole system (e.g., arms, legs, and torso). Full-system tests should be carried out to determine if the modeling and experimental predictions and the testing methodology developed are adequate.

The testing of unconstrained sleeves should be tested to determine particle penetration performance and compared to the equivalent bench top swatch results.

New particles with discreet properties, such as size and fluorescent excitation frequency uniqueness will need to be developed to assist in deposition measurements. The overall goal should be both an improved testing methodology and improved design capability.

REFERENCES

1. Irshad, H., McFarland, A.R., Landis, M.S., Stevens, R.K., "Wind Tunnel Evaluation of an Aircraft-Borne Sampling System," *Aerosol Science and Technology*, 38:311-324, 2004.
2. Stewart, V.R., Naval Air Warfare Center, Warminster, PA Aerodynamic Test Facility Operation Instructions, KSA Technology Report, Columbus, OH, Aug 1996.
3. Hill, J.S., Hanley, J.T., "Aerosol Swatch Tests of JSLIST Fabric," RTI Project Number 09453.002, RTI International, Sep 2005.
4. Hinds, W.C., Aerosol Technology, Second Edition, John Wiley & Sons, Inc., New York, NY, 1999.
5. Hoerner, S.F., Fluid-Dynamic Drag, Hoerner Fluid Dynamics, Vancouver, WA, 1965.
6. Hill, M.A., Dhaniyala, S., Ghee, T.A., Kaufman, J., "Investigation of Aerosol Penetration through Individual Protective Equipment in Elevated Wind Conditions." presented at the AAAR 26th Annual Conference, Reno, NV, Sep 2007. NAWCADPAX/TR-2012/365, 1 Mar 2013. *Aerosol Science and Technology*, Volume 47, Issue 7, pp. 705-713, Apr 2013.
7. NAWCAD Patuxent River Report No. NAWCADPAX/TIM-2014/7, Swatch Testing at Elevated Wind Speeds, of 17 Jul 2014.
8. Barlow, J., B., Rae, W.H., Pope, A. Low-Speed Wind Tunnel Testing, 3rd Edition, Wiley, NY, 1999.
9. Ghee, T.A., Murphy, K.L., "A Method to Correlate Ambient Wind to Fabric Face Velocity and Permeability." AIAA-2011-311. Proceedings of the 49th AIAA Aerospace Sciences Meeting, Orlando, FL, Jan 2011.
10. Bergman, W., Fedele, P.D., McCallen, R., Sutton, S., "Hydrodynamically Induced Aerosol Transport," *Proceedings of the 1985 Scientific Conference on Chemical Defense Research*, Aberdeen Proving Ground, MD, Apr 1986.
11. NAWCAD Patuxent River Report No. NAWCADPAX/TIM-2014/26, Effect of Yaw Angle and Ambient Wind on Fabric Penetration of a Simulated Sleeve, not yet published.
12. Akima, H., "A New Method of Interpolation and Smooth Curve Fitting Based on Local Procedures", *Journal of the Association for Computing Machinery*. Vol. 17, No. 4, Oct 1970.

THIS PAGE INTENTIONALLY LEFT BLANK

APPENDIX A
FIGURES

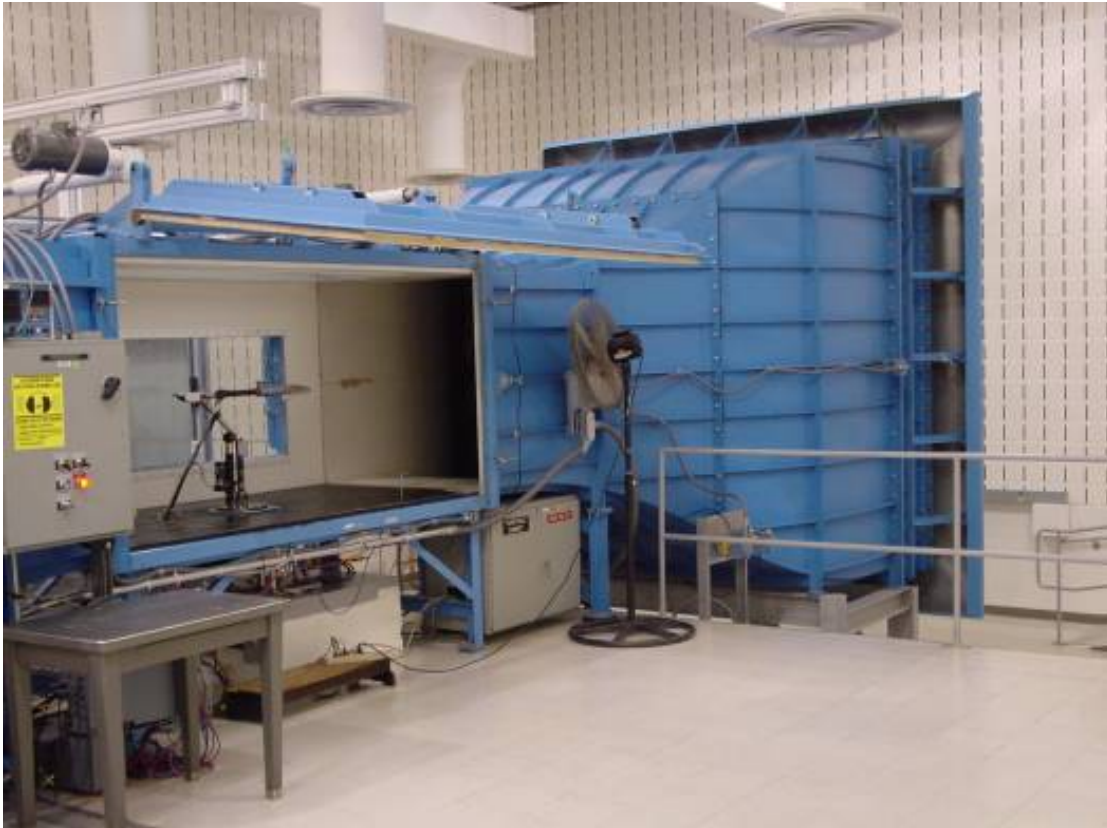

Figure A-1: NATF

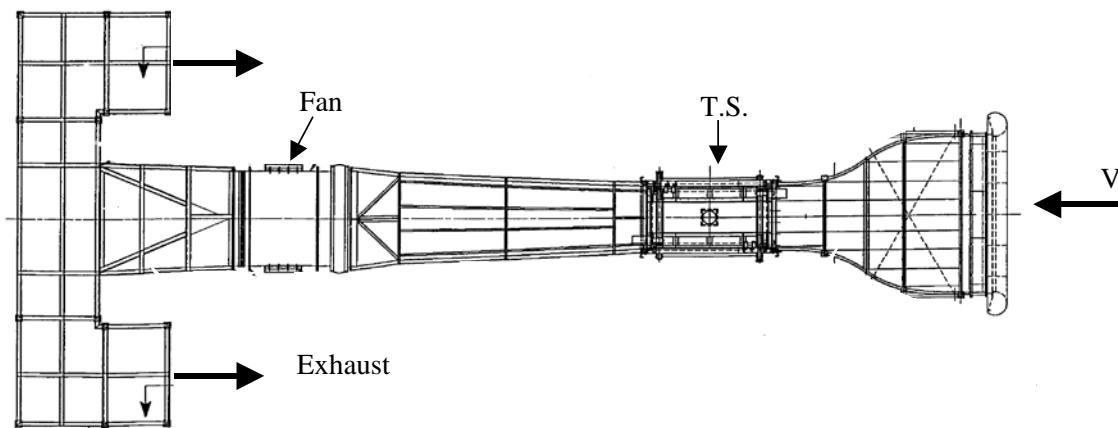

Figure A-2: Schematic of NATF

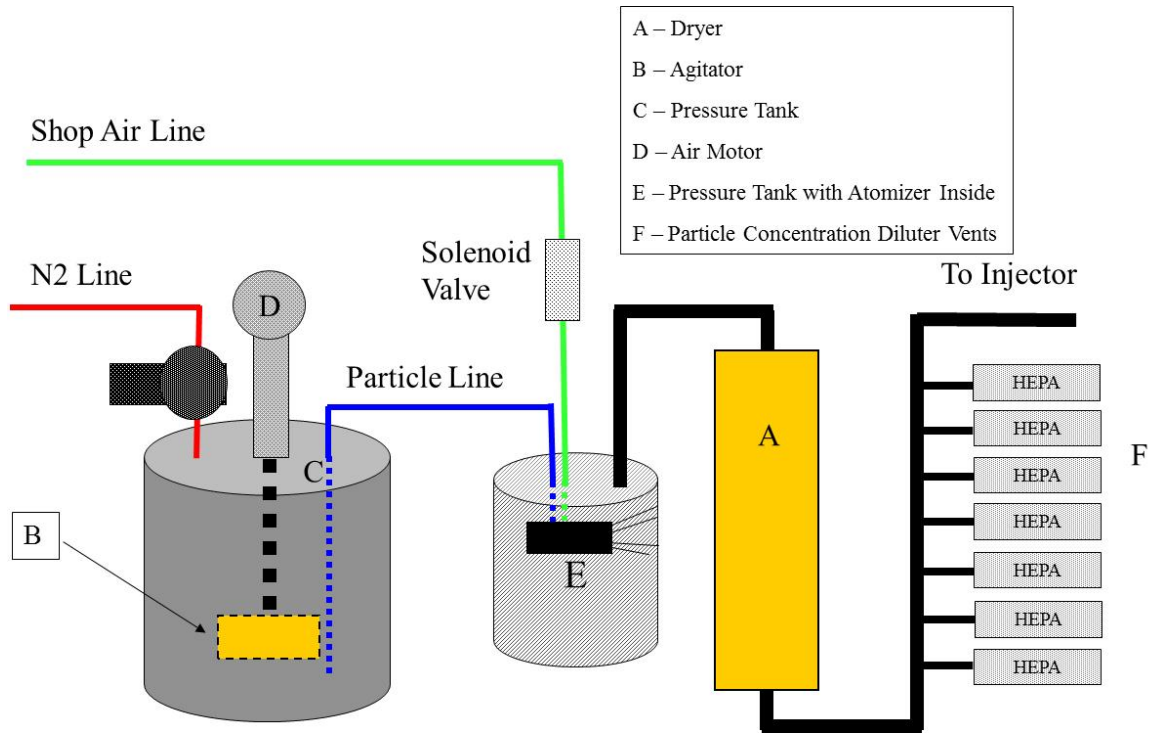

Figure A-3: Schematic of Dissemination System



Figure A-4: Dissemination System

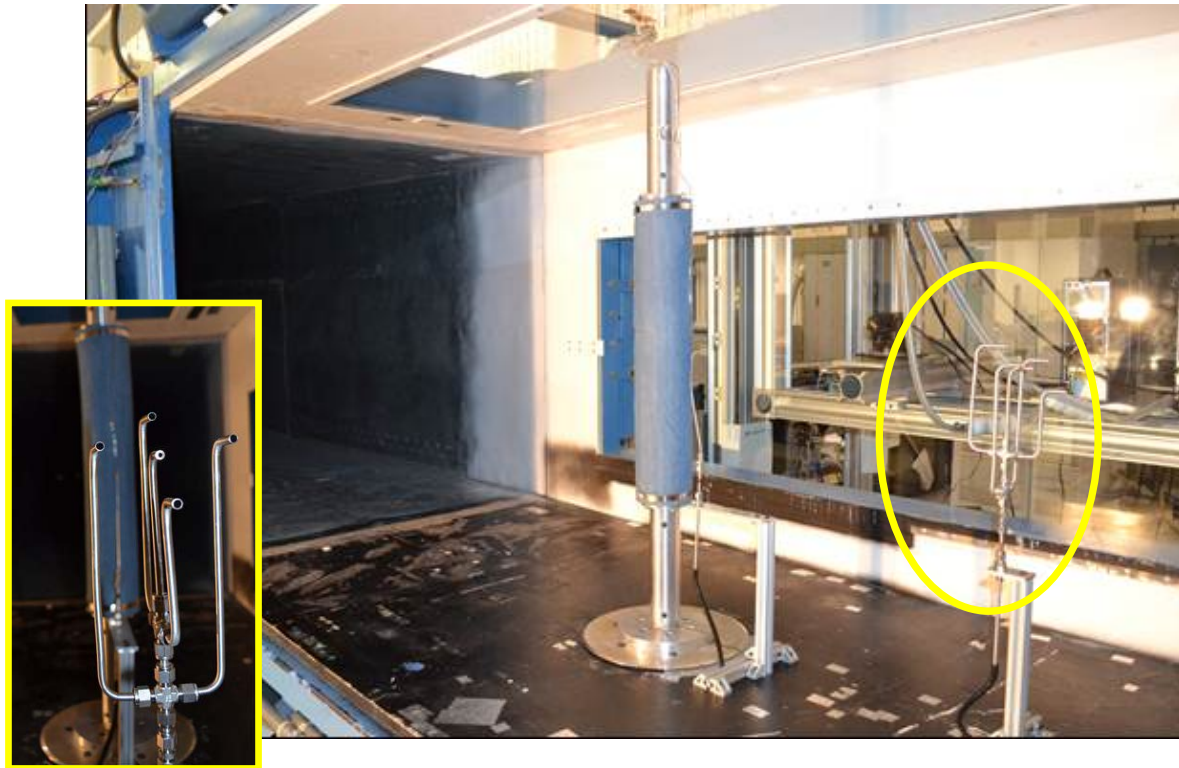

Figure A-5: Wind Tunnel Ejectors, Inset: Front View

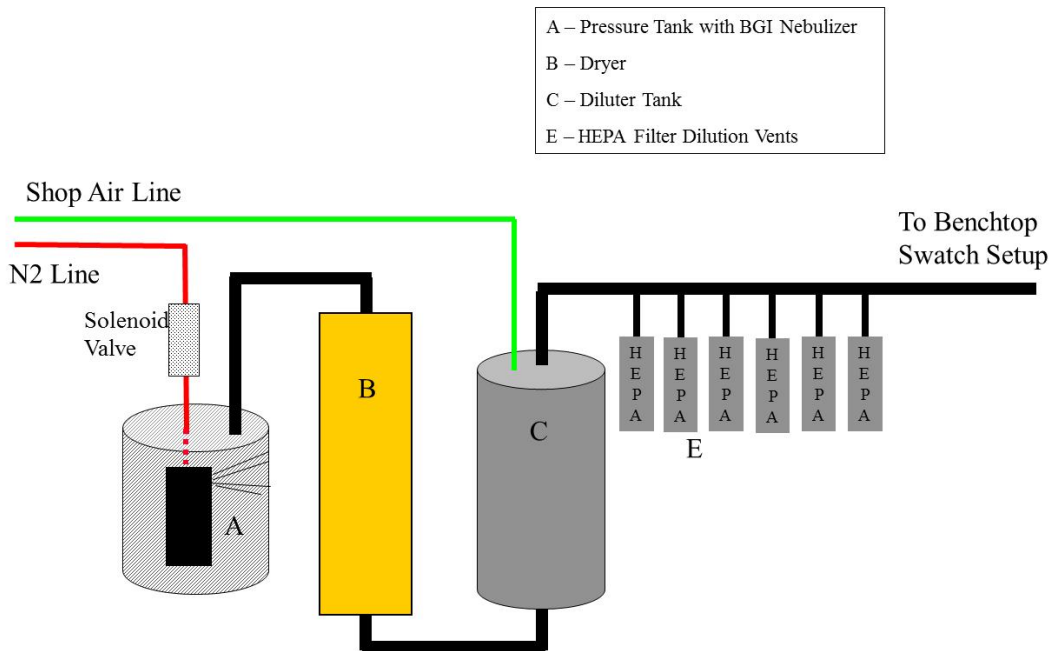

Figure A-6: Schematic of NAVAIR Bench Top Dissemination System

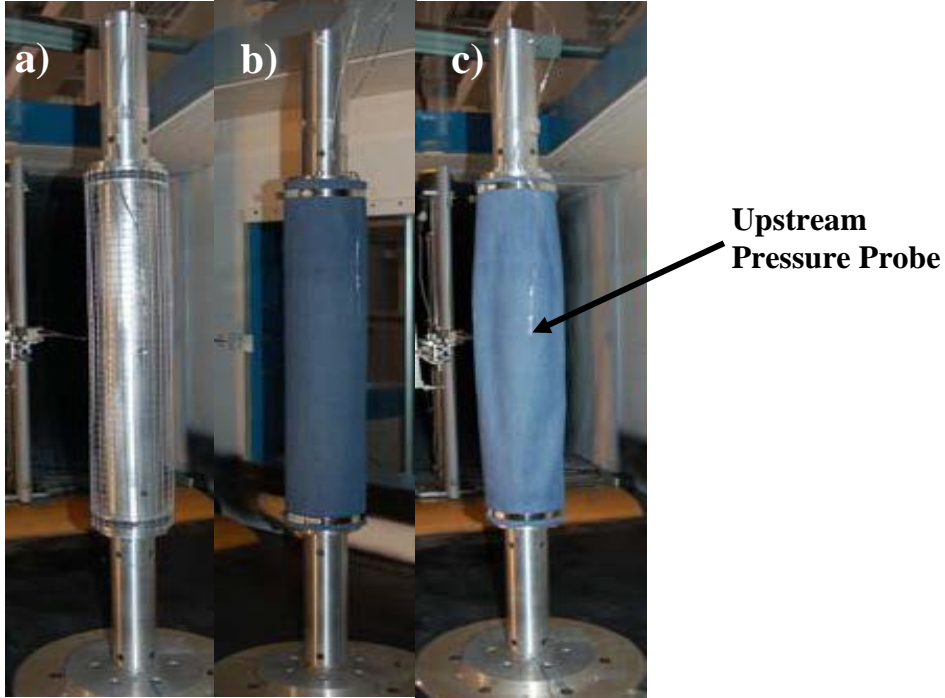

Figure A-7: Component Fixture a) Support Screen, b) with Installed Sleeve Over the Support Screen, c) with Installed Sleeve without Support Screen

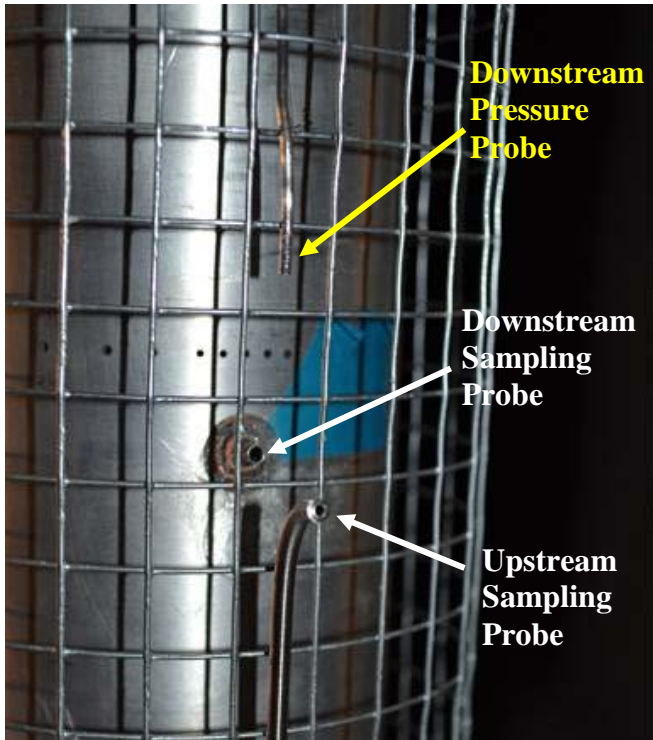

Figure A-8: Front of Wind Tunnel Swatch Holder with Upstream Sampling Probe and Static Pressure Probe

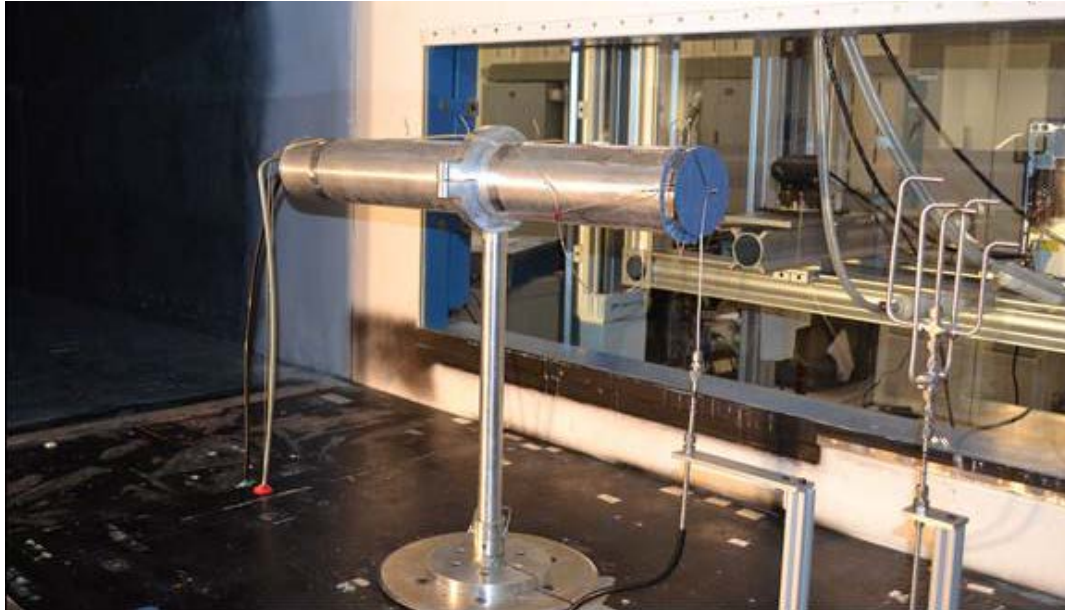

Figure A-9: Wind Tunnel Swatch Model in Wind Tunnel

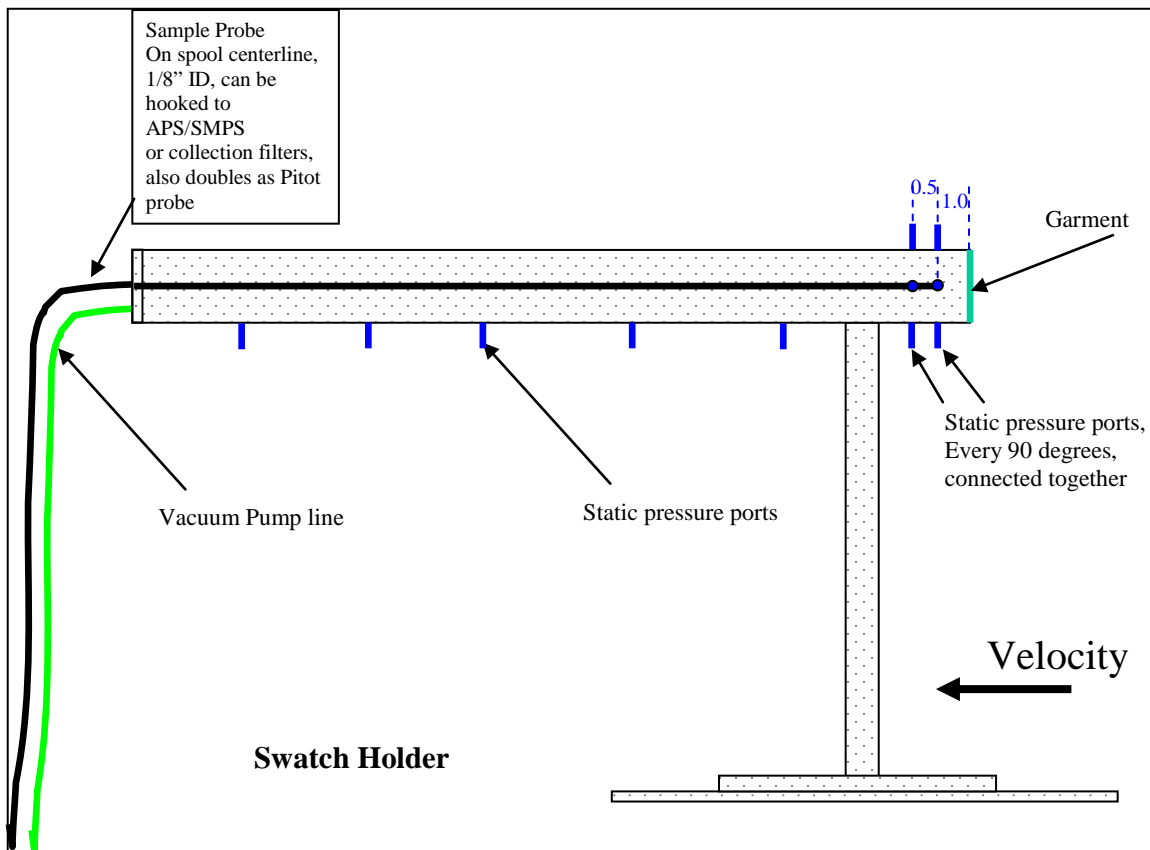

Figure A-10: Schematic of the Swatch Holder in the NATF Wind Tunnel

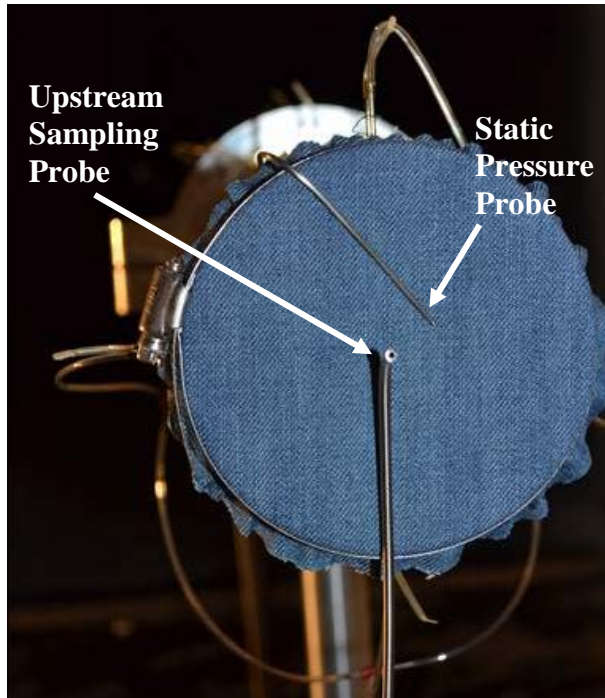

Figure A-11: Front of Wind Tunnel Sleeve Fixture with Upstream Sampling Probe and Static Pressure Probe

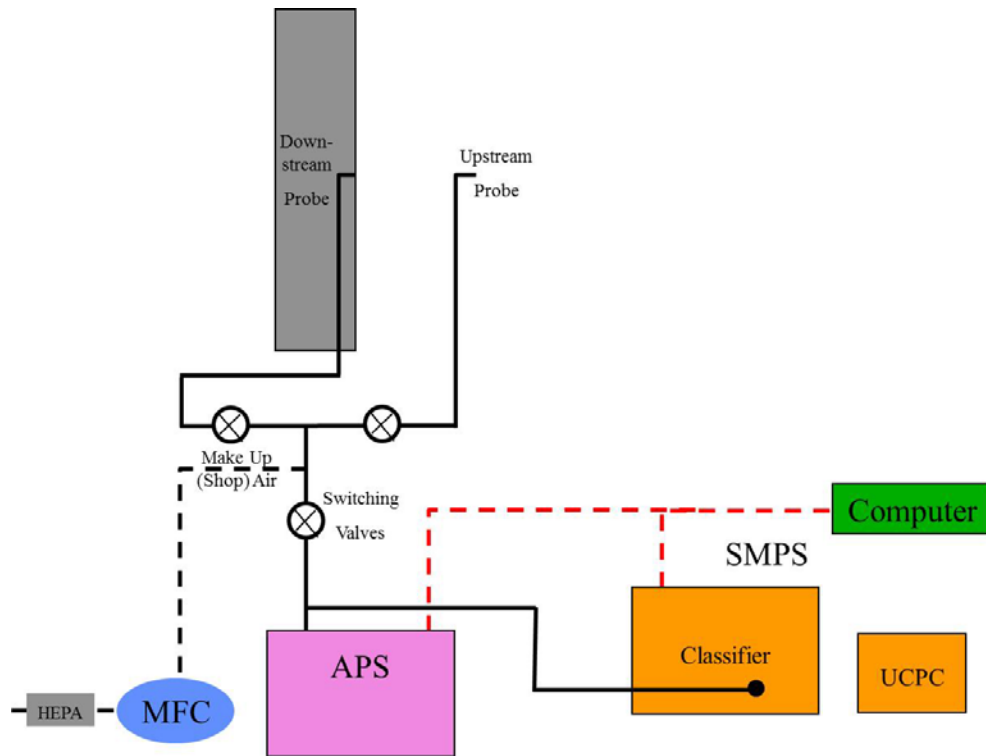

Figure A-12: Schematic of Wind Tunnel Sleeve Fixture Sampling DOS Challenge

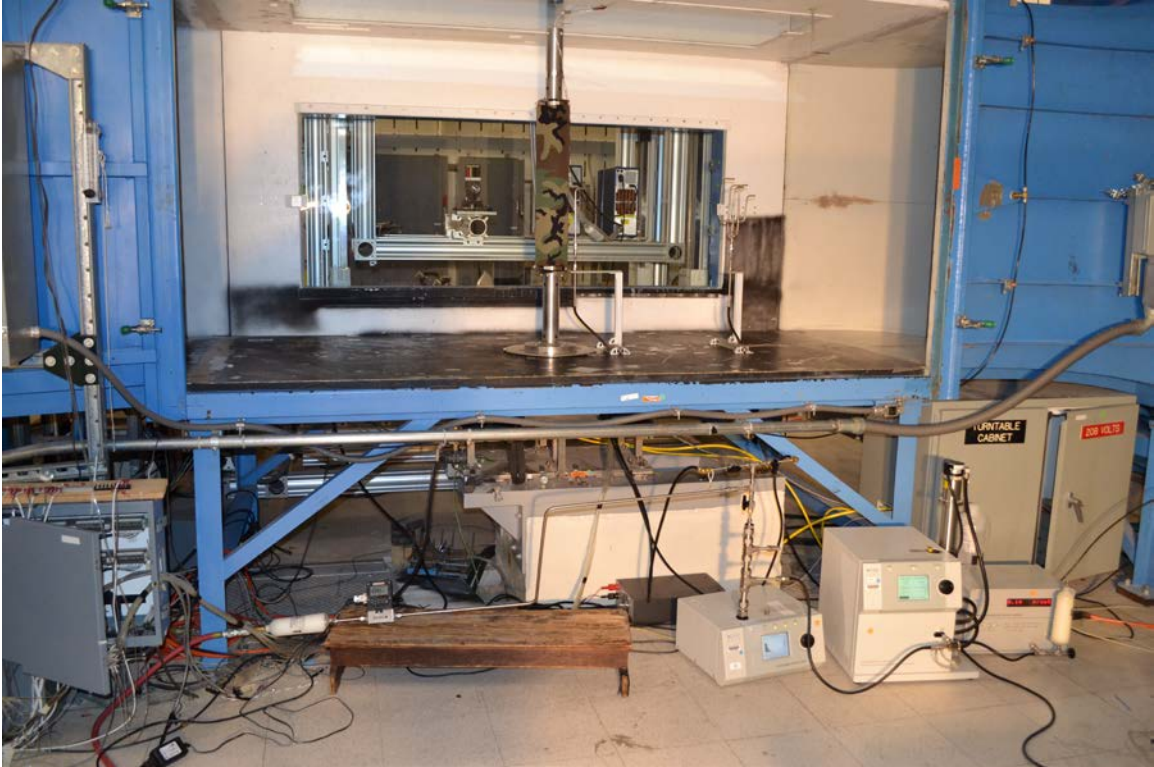

Figure A-13: Test Setup for Wind Tunnel Sleeve Testing

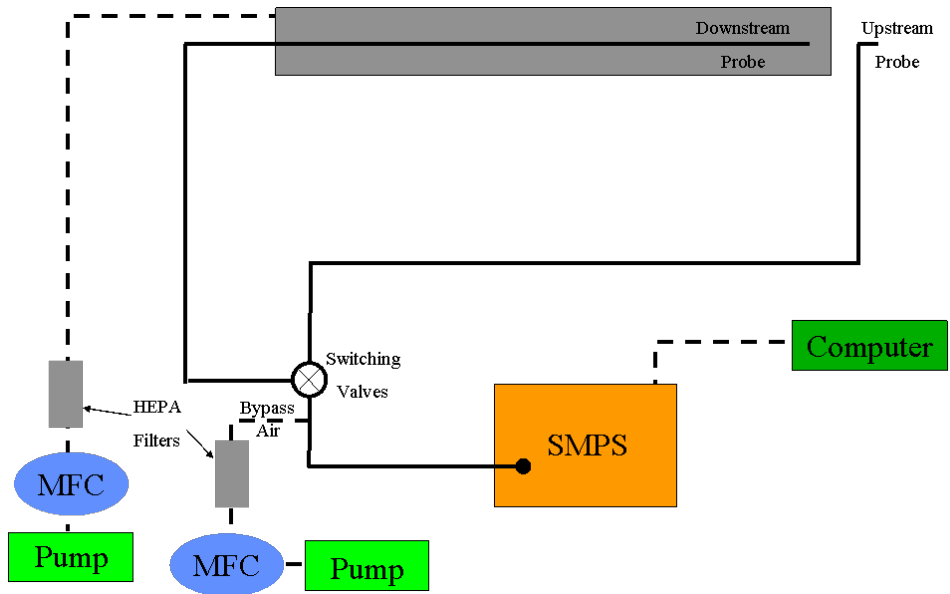

Figure A-14: Schematic of Wind Tunnel Switch Holder Aerosil Challenge

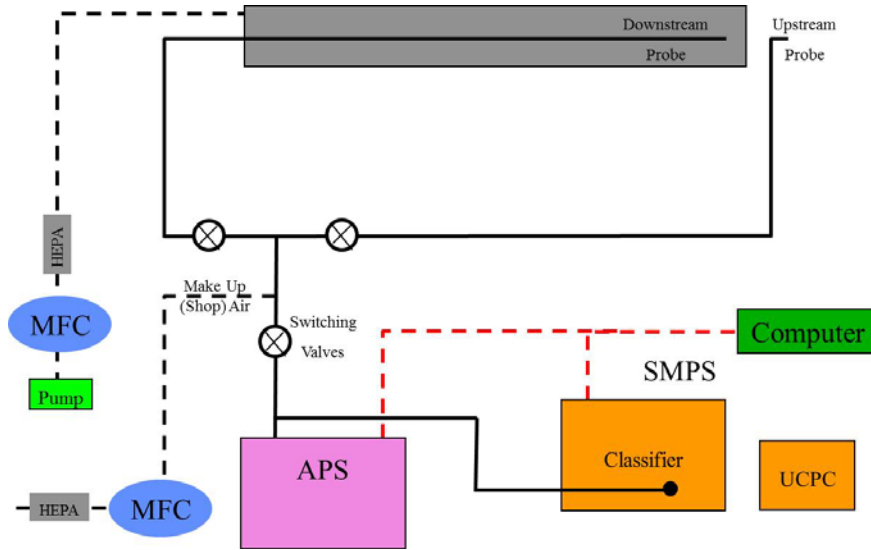

Figure A-15: Schematic of Wind Tunnel Switch Holder DOS Challenge, Low Wind Tunnel Speed

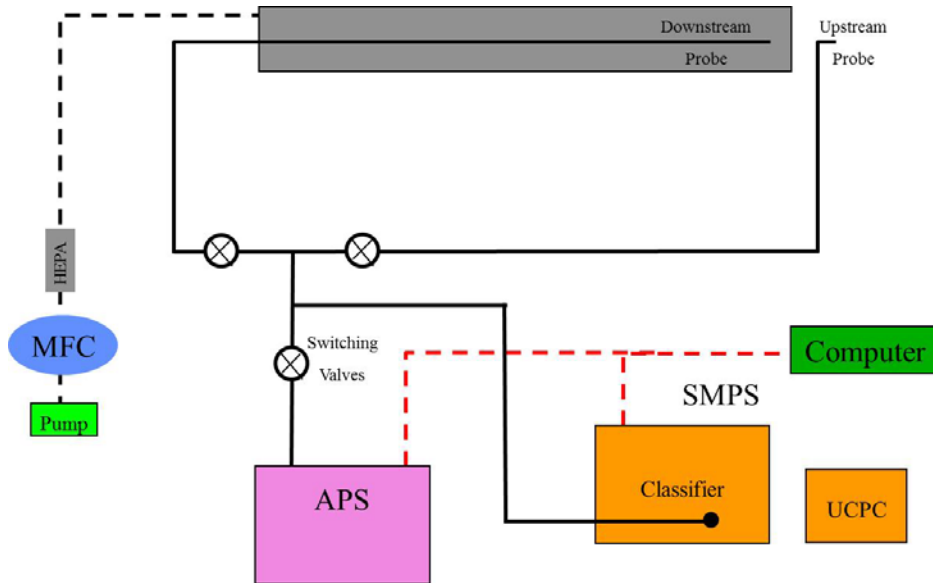

Figure A-16: Schematic of Wind Tunnel Switch Holder DOS Challenge, High Wind Tunnel Speed



Figure A-17: Test Setup for Wind Tunnel Switch Testing

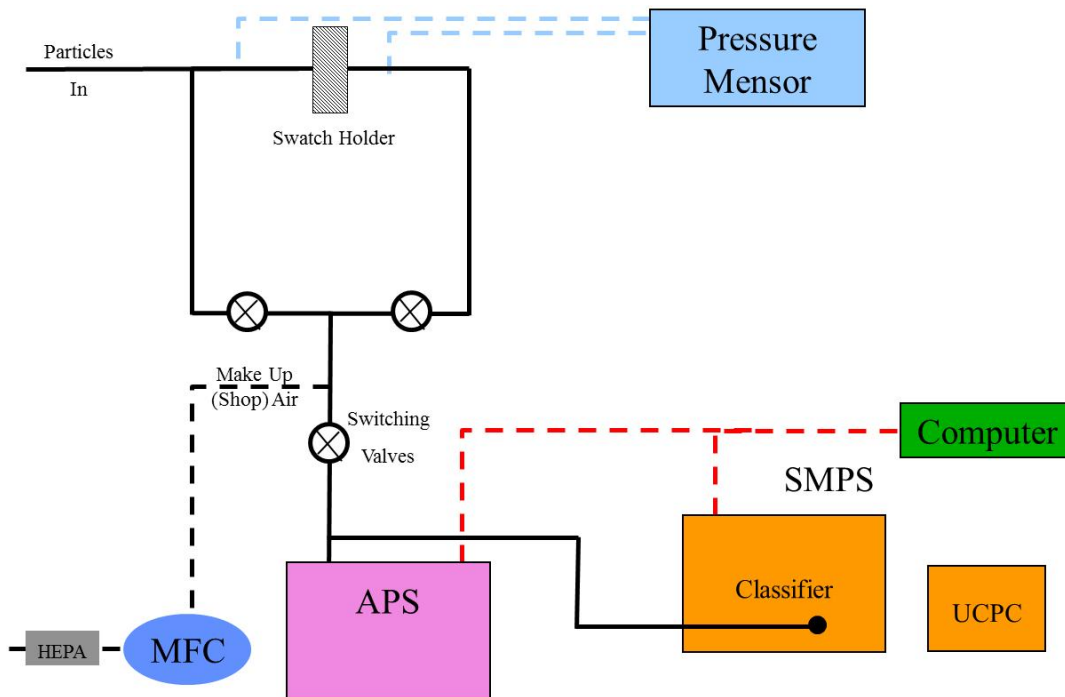

Figure A-18: Schematic of NAVAIR Bench Top Testing System



Figure A-19: NAVAIR Bench Top Testing System (DOS Challenge)

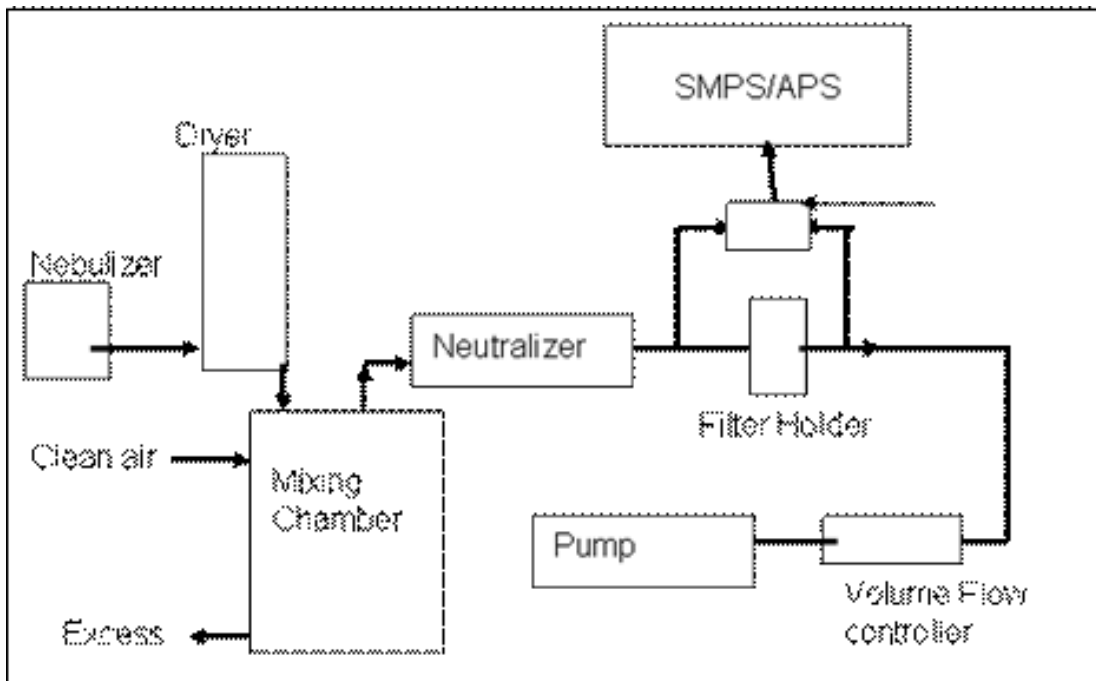

Figure A-20: Schematic of Bench Top Setup at Clarkson University, reference 6



Figure A-21: Clarkson Bench Top Filter Test Setup

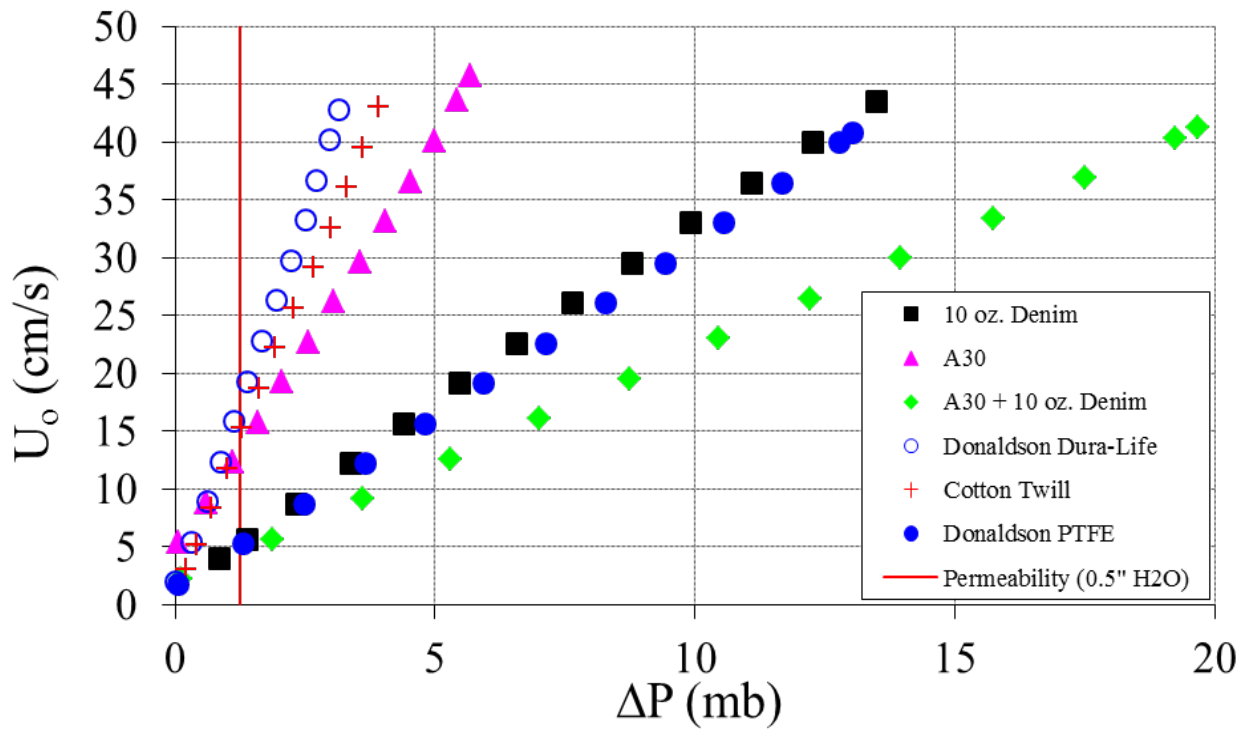

Figure A-22: Face Velocity Variation with Pressure Drop for Various Materials

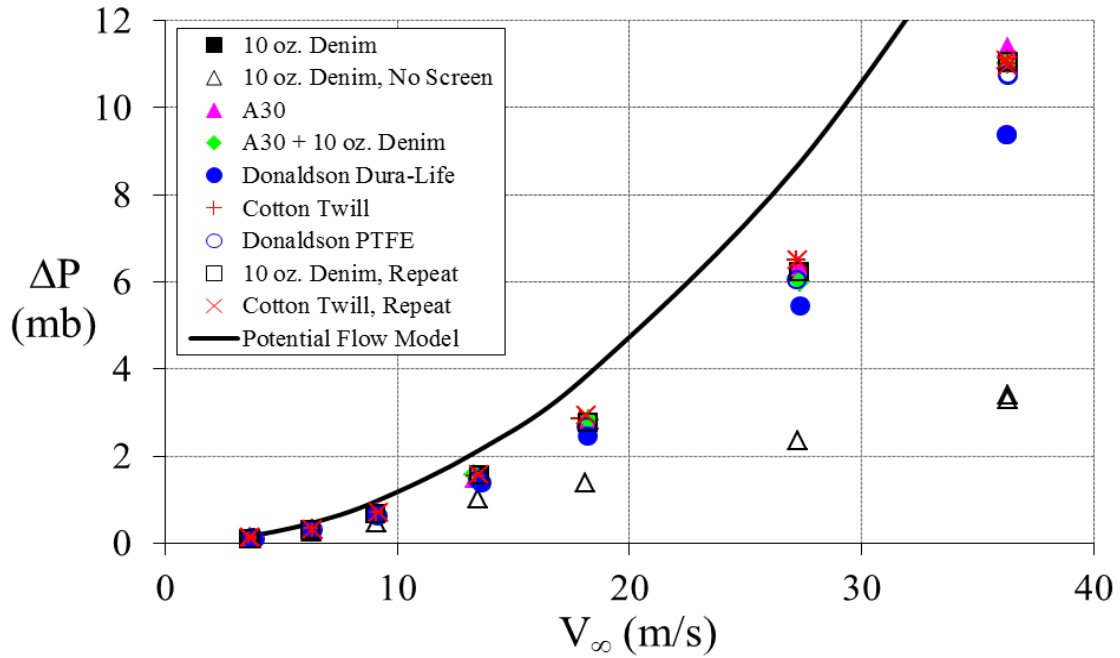

Figure A-23: Fabric Pressure Drop as a Variation with Wind Tunnel Velocity at Stagnation Point for a Variety of Fabrics

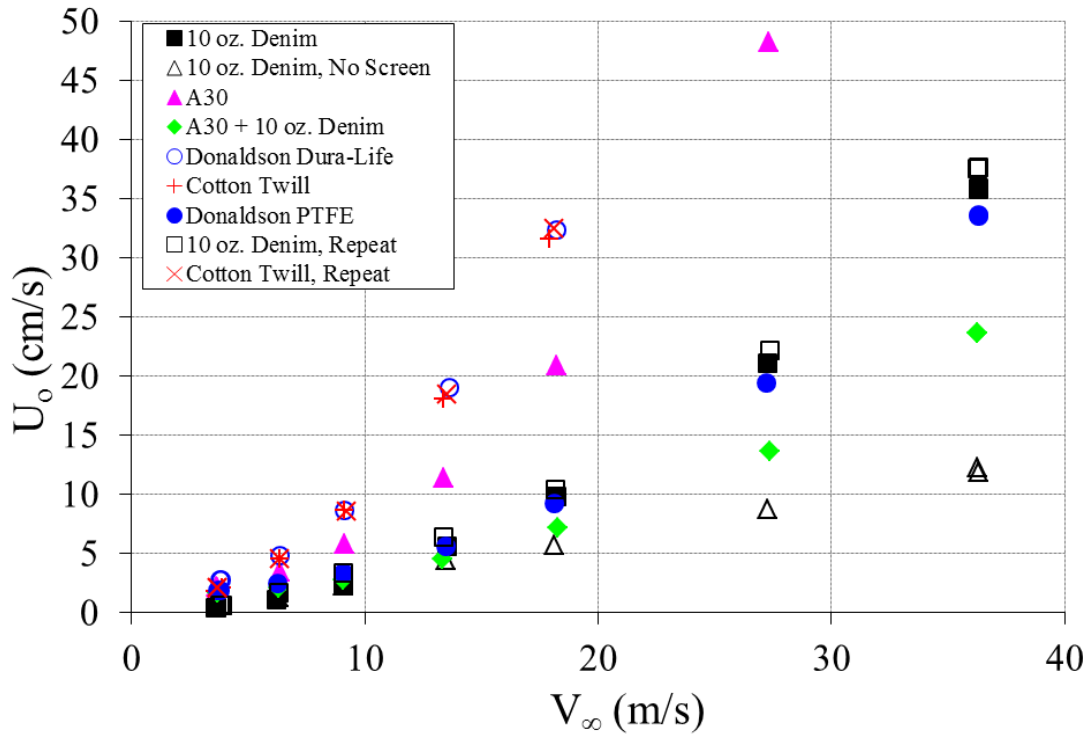

Figure A-24: Face Velocity Variation with Wind Tunnel Speed Determined from Wind Tunnel Sleeve Testing

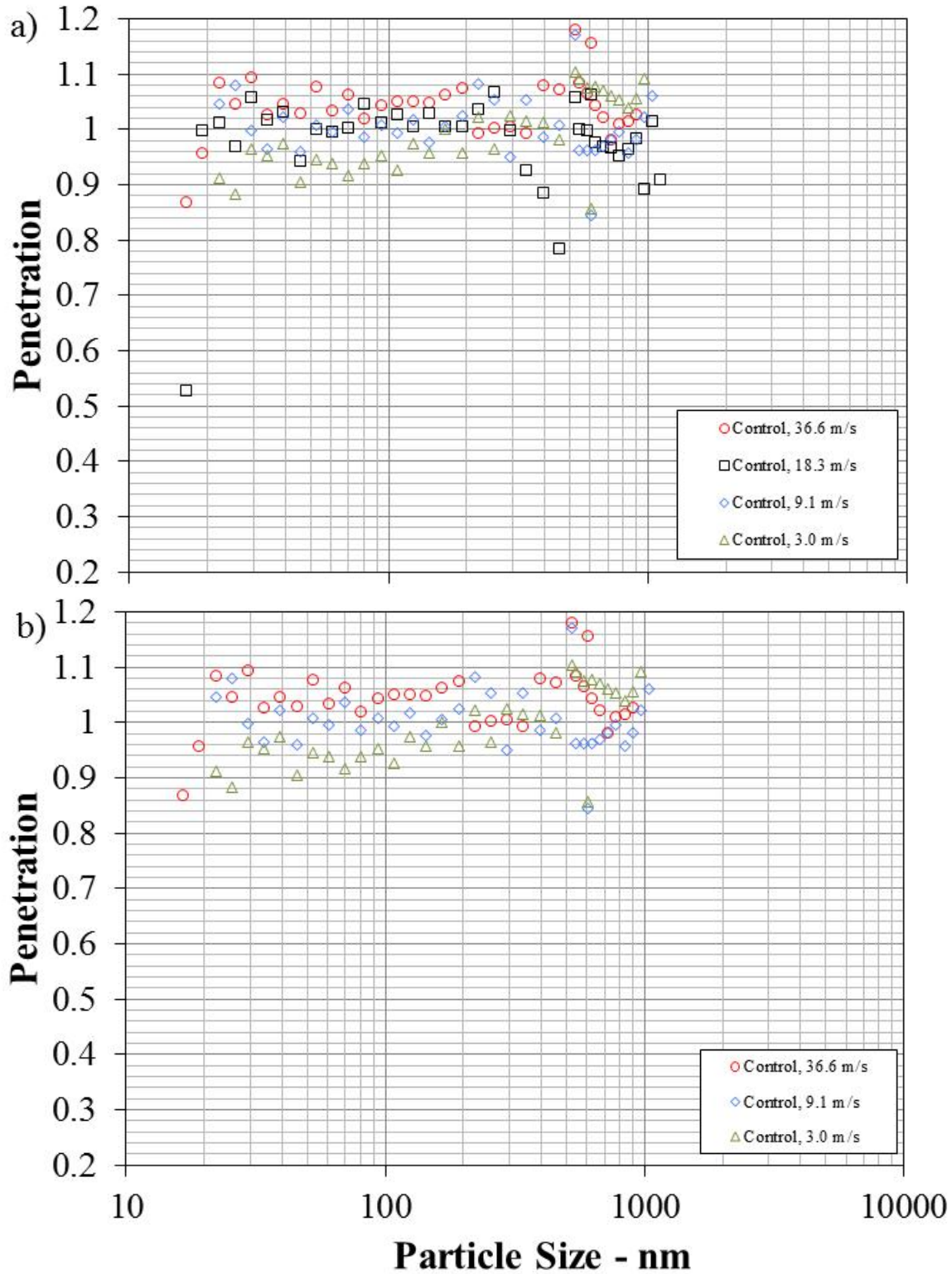

Figure A-25: Control (No Fabric Sleeve) Component Sleeve Test: a) DOS Challenge, b) Aerosil Challenge

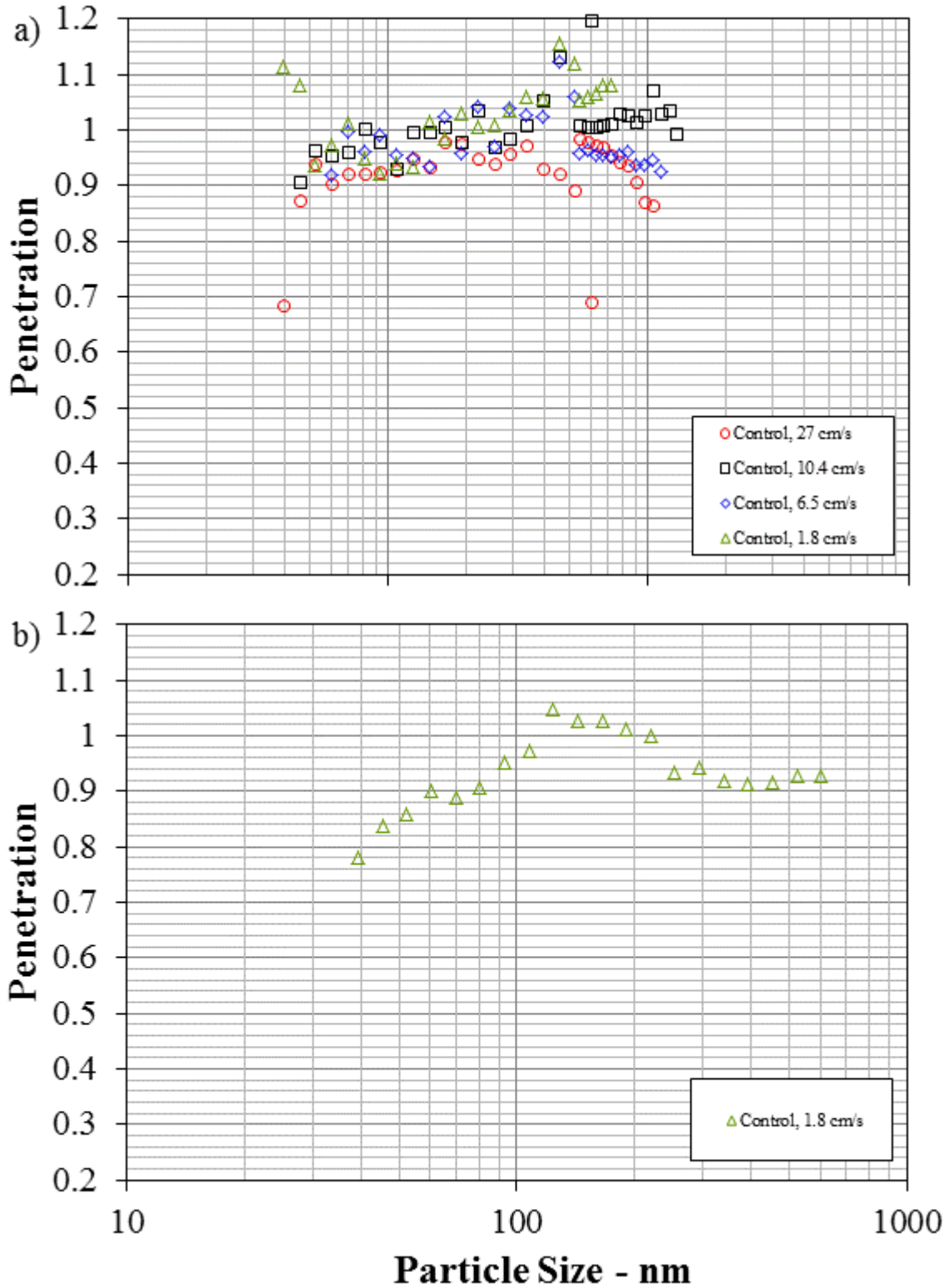

Figure A-26: Control (No Fabric Swatch) Bench Top Swatch Test: a) DOS Challenge, b) Aerosil Challenge

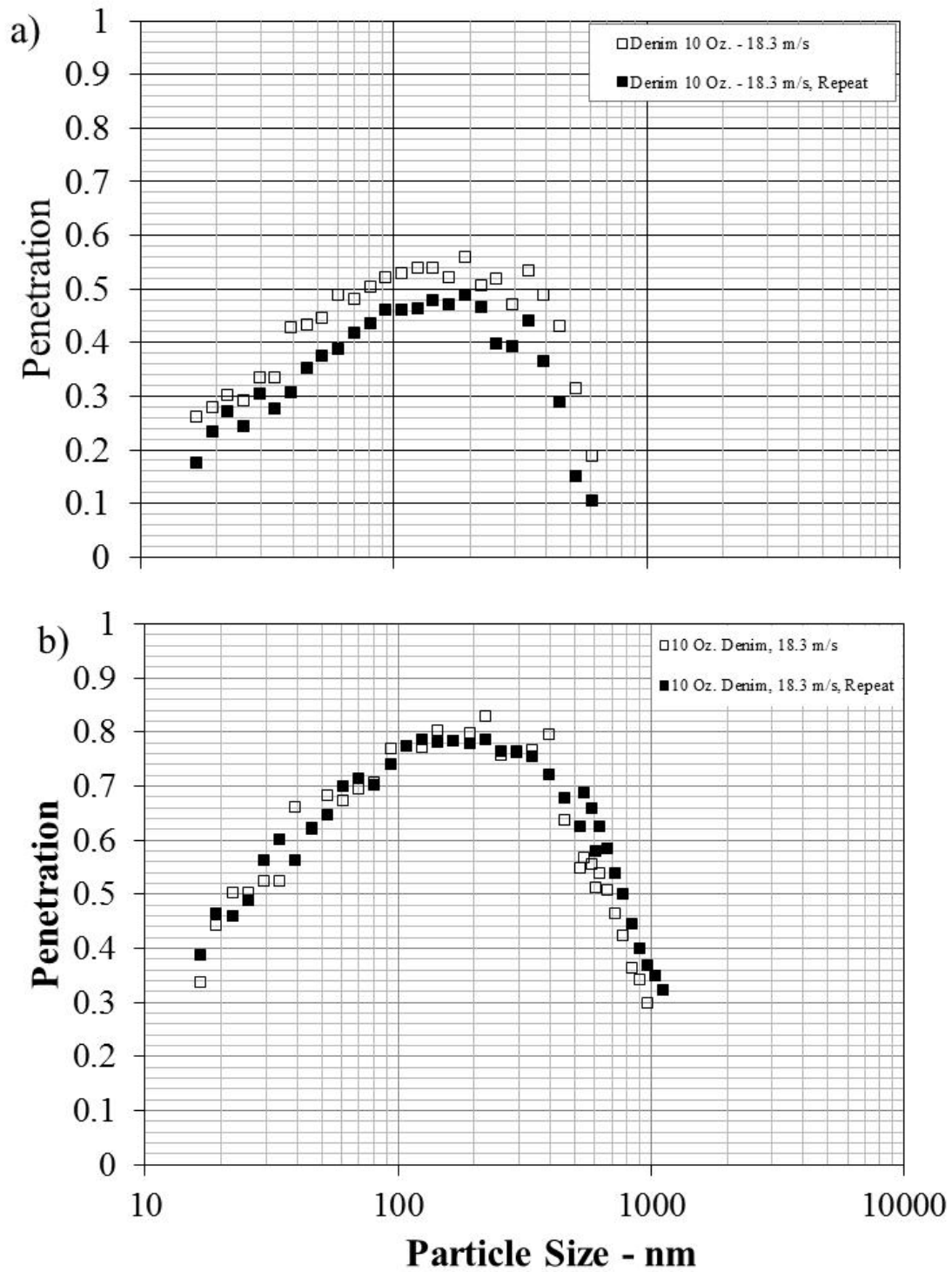

Figure A-27: System Repeatability, Wind Tunnel Sleeve Testing, 18.3 m/s: a) Aerosil Challenge, b) DOS Challenge

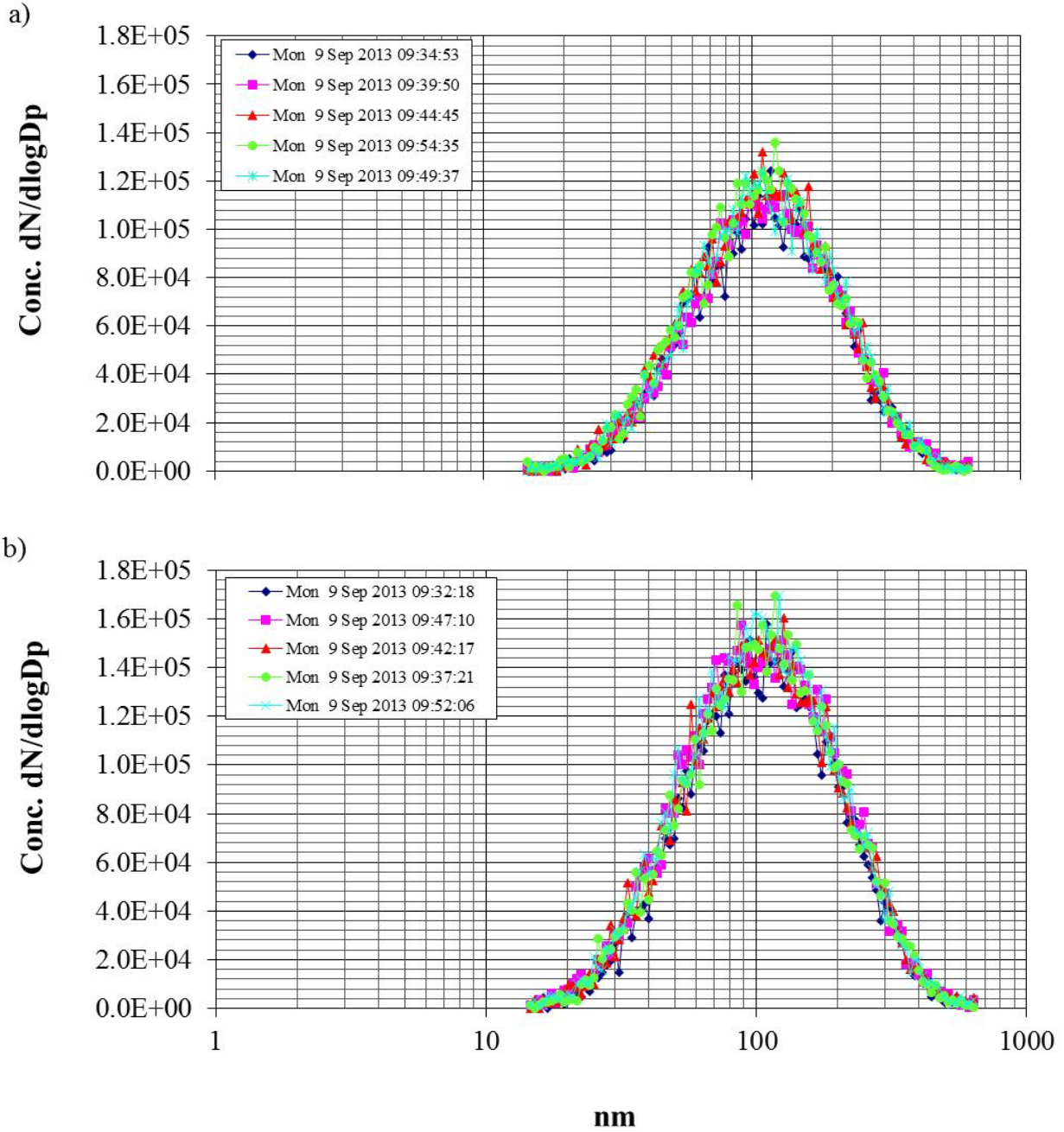

Figure A-28: Typical In-Test Repeatability, Component Test, DOS Challenge, 10 Oz. Denim, $V_{\infty} = 18.3$ m/s: a) Downstream Sample, b) Upstream Sample

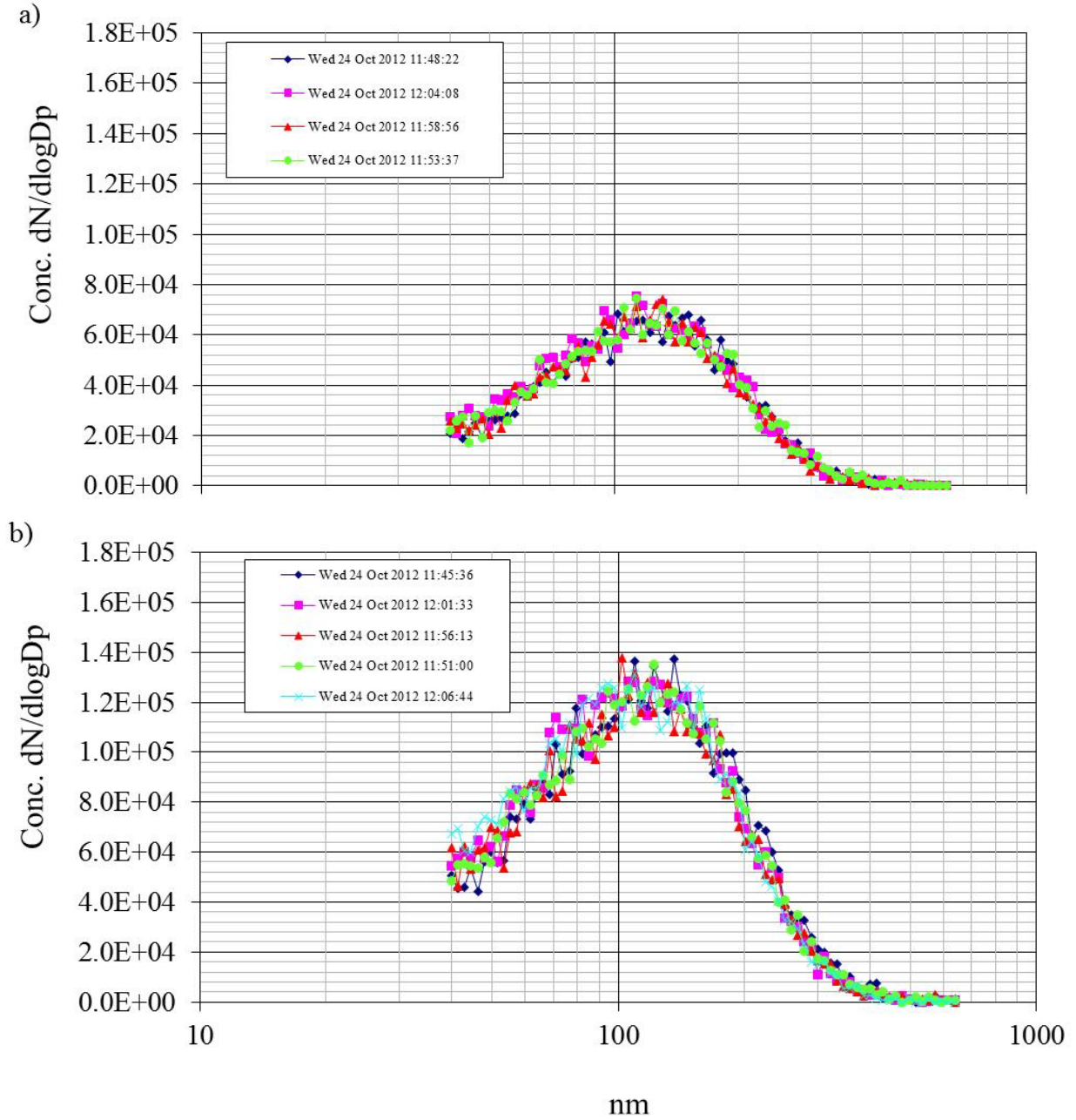

Figure A-29: Typical In-Test Repeatability, Bench Top, Aerosil Challenge, 10 Oz. Denim, $V_\infty = 18.3$ m/s: a) Downstream Sample, b) Upstream Sample

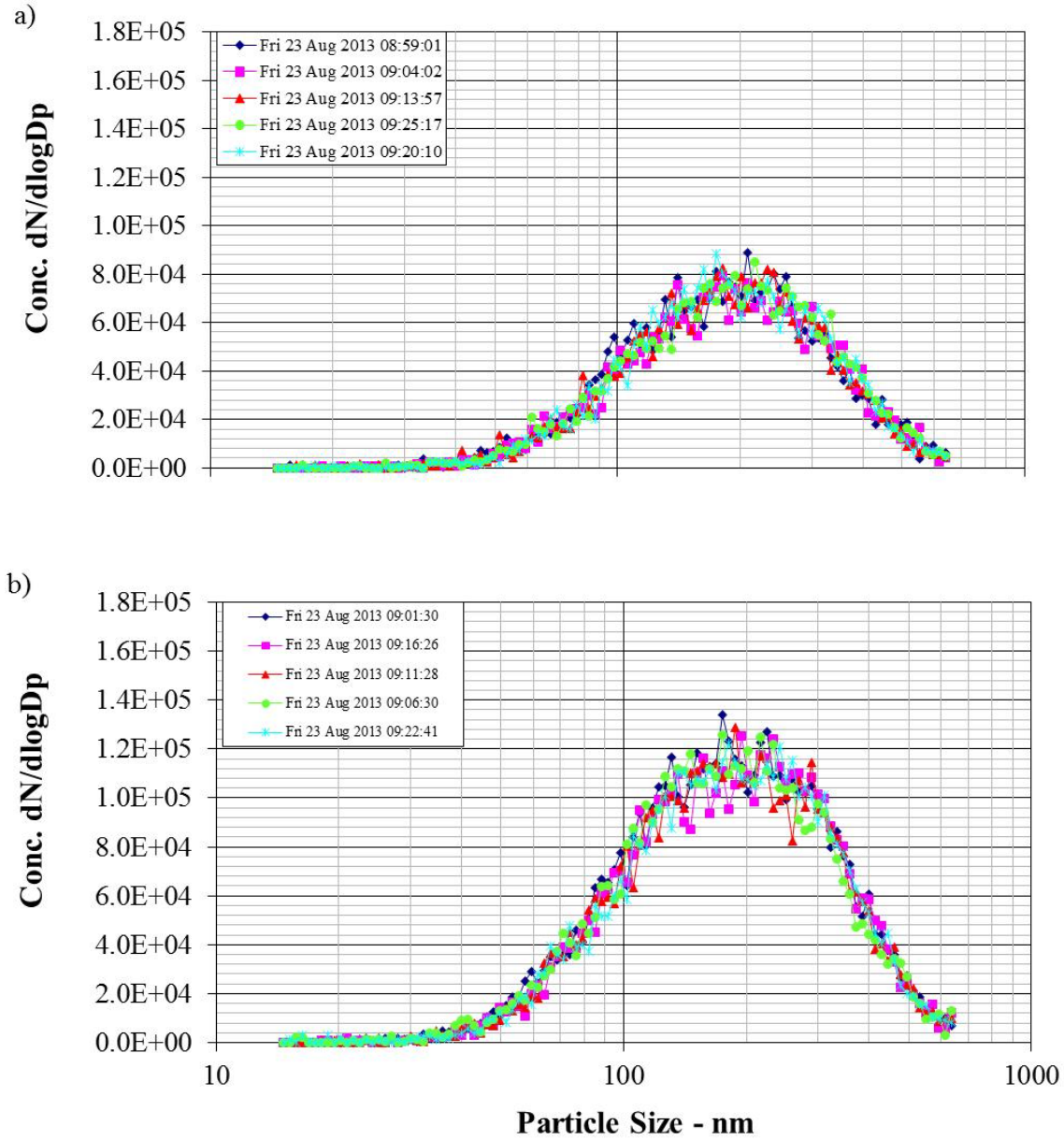

Figure A-30: Typical In-Test Repeatability, Bench Top Swatch, DOS Challenge, 10 Oz. Denim, $U_o = 10.4$ cm/s: a) Downstream Sample, b) Upstream Sample

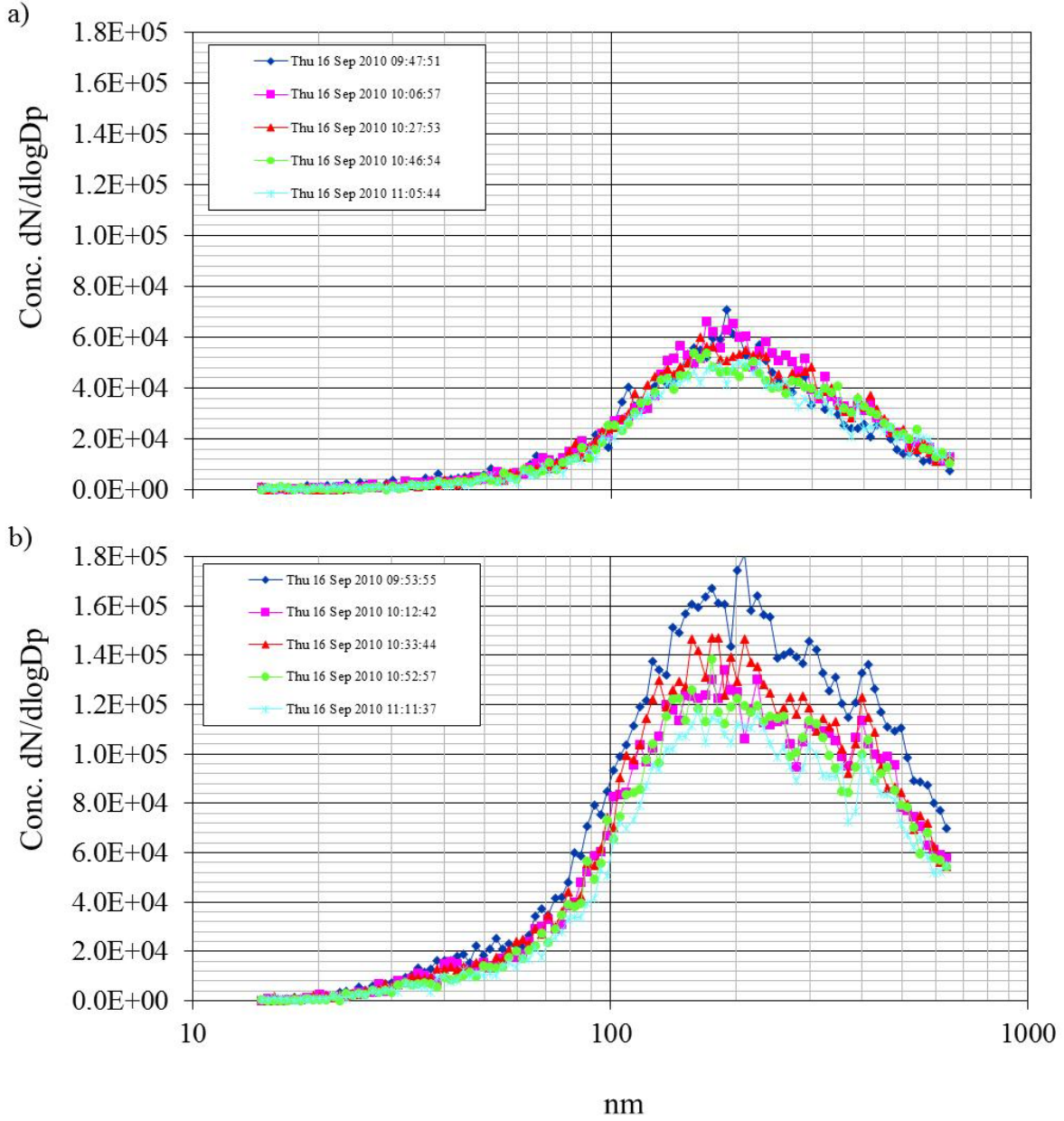

Figure A-31: Typical In-Test Repeatability, Bench Top Swatch, Aerosil Challenge, 10 Oz. Denim, $U_o = 10.4$ cm/s: a) Downstream Sample, b) Upstream Sample

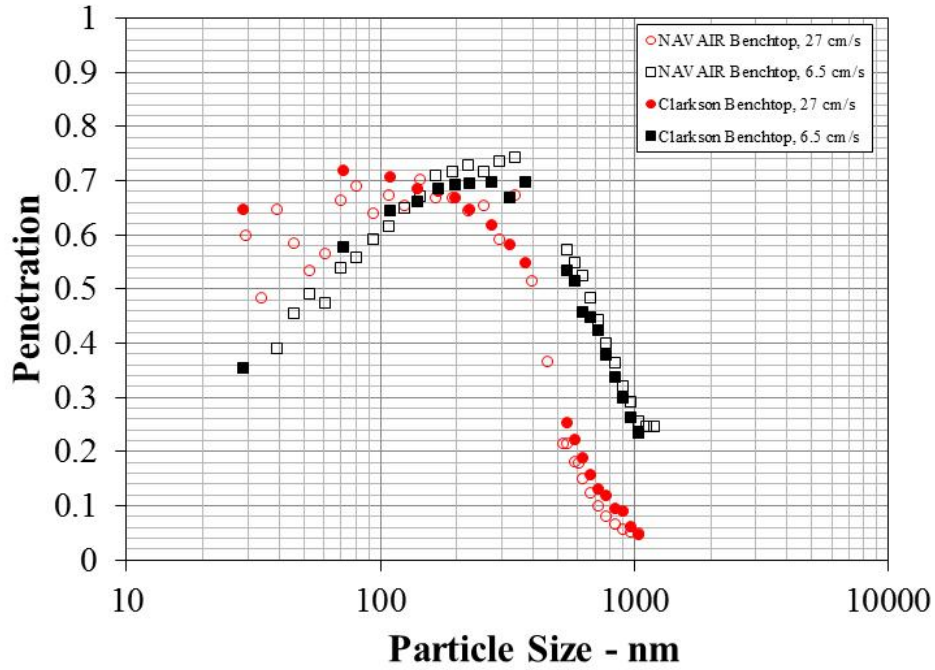

Figure A-32: Comparison of Clarkson and NAVAIR Bench Top Swatch Test Systems (Clarkson Data from reference 6)

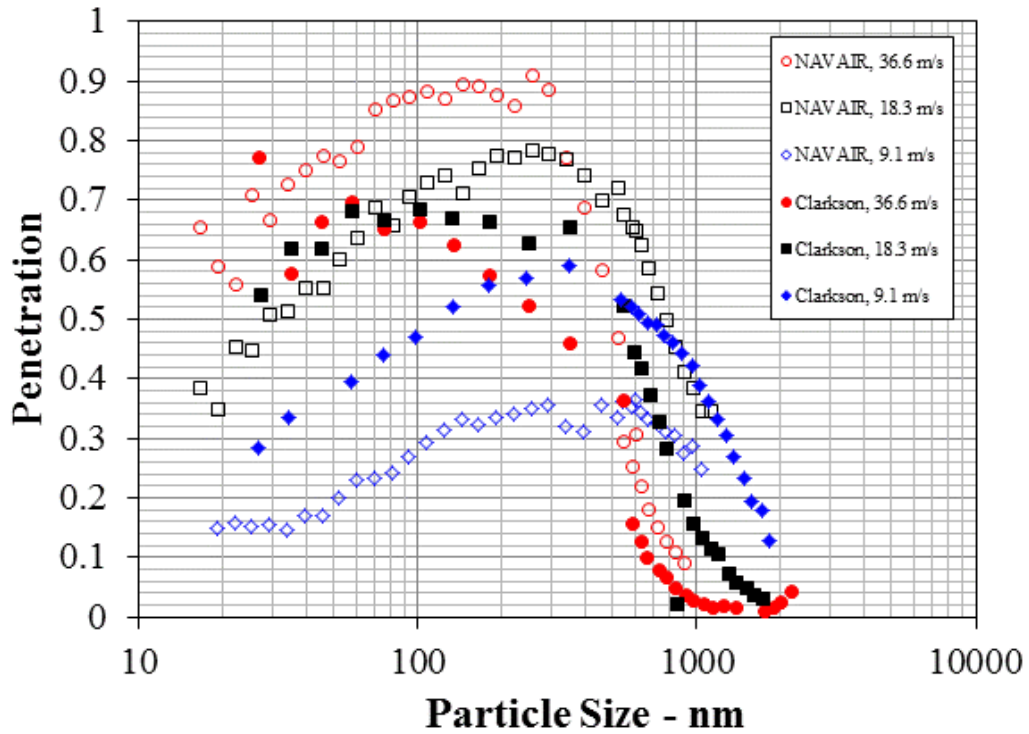

Figure A-33: Comparison of Clarkson and NAVAIR Wind Tunnel Sleeve Test Systems (Clarkson Data from reference 6)

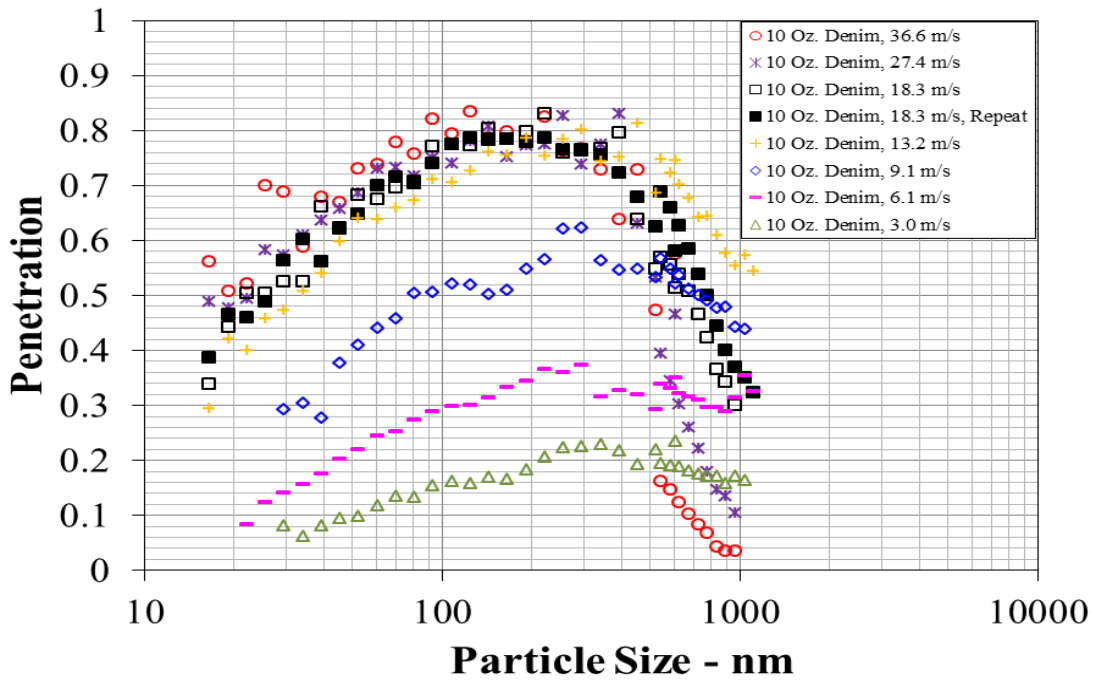

Figure A-34: Penetration Data for 10 Oz. Denim, DOS Challenge

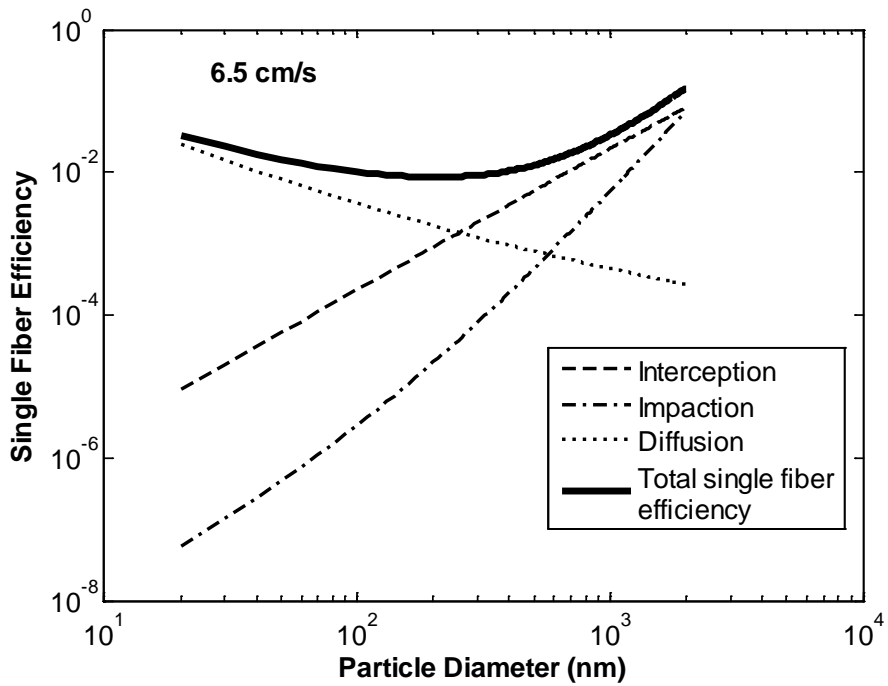

Figure A-35: Contribution of Filtration Mechanisms for 6.5 cm/s Face Velocity (from reference 6)

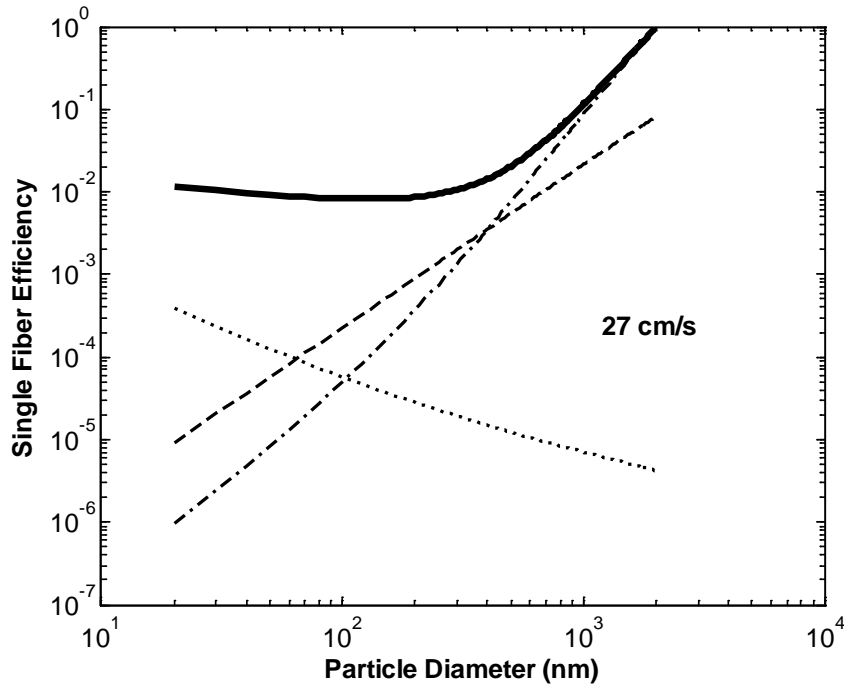

Figure A-36: Contribution of Filtration Mechanisms for 27 cm/s Face Velocity (from reference 6)

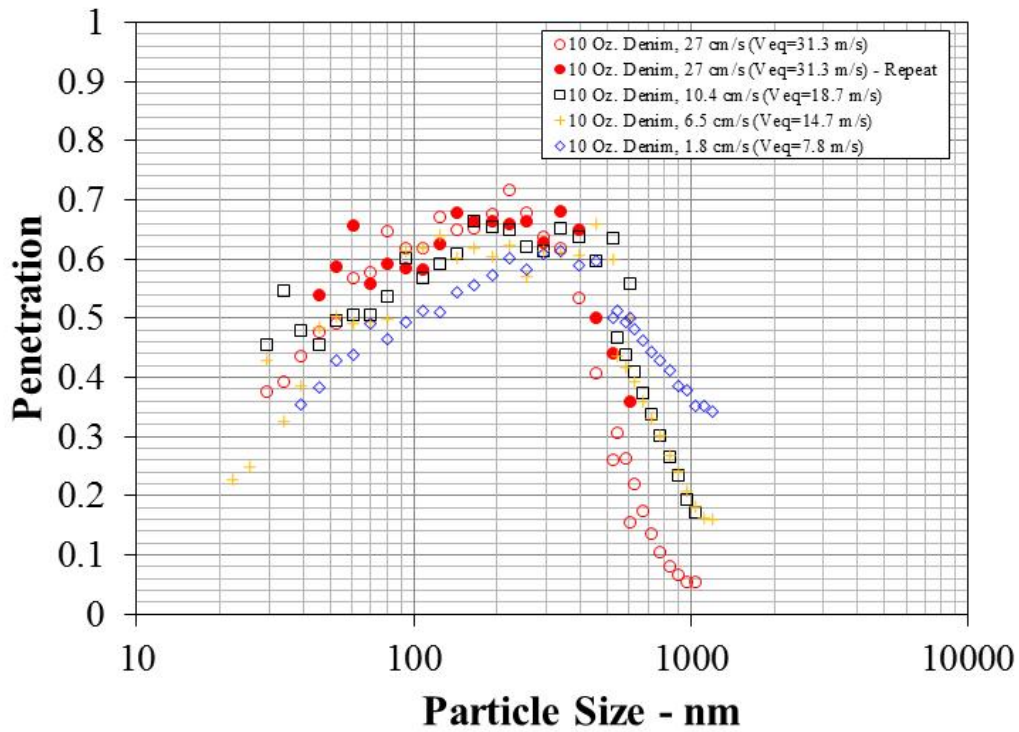

Figure A-37: Bench Top Swatch Test, Increasing Face Velocity, DOS Challenge

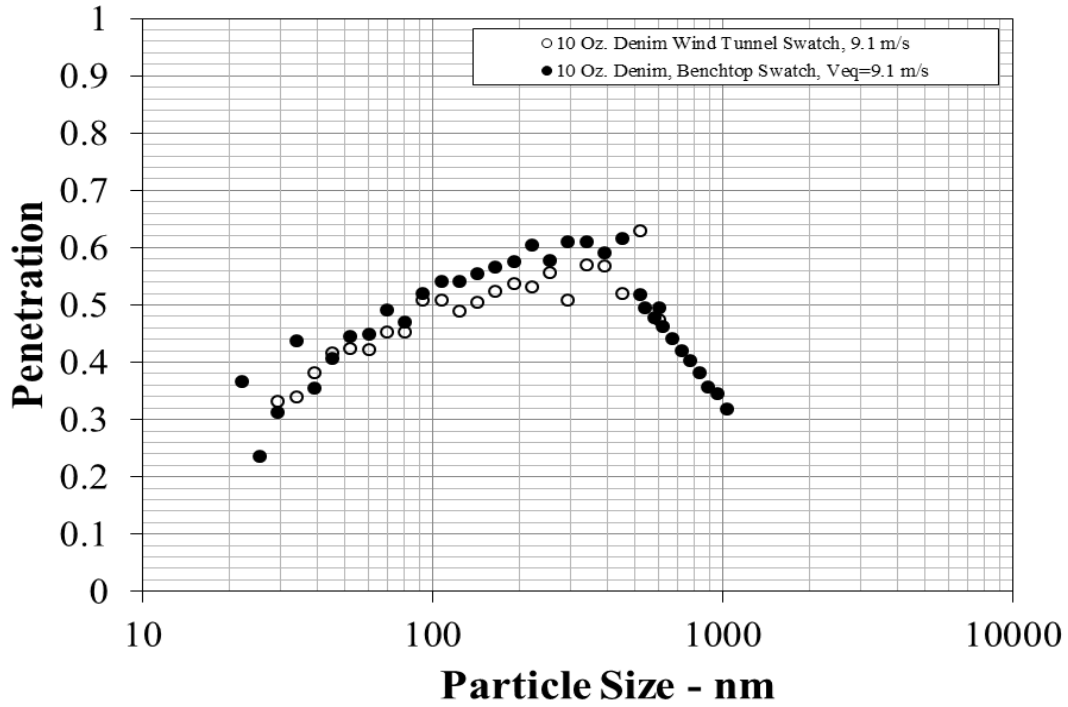

Figure A-38: Comparison of Wind Tunnel and Bench Top Swatch Results, DOS Challenge, $V_{\infty}=9.1$ m/s

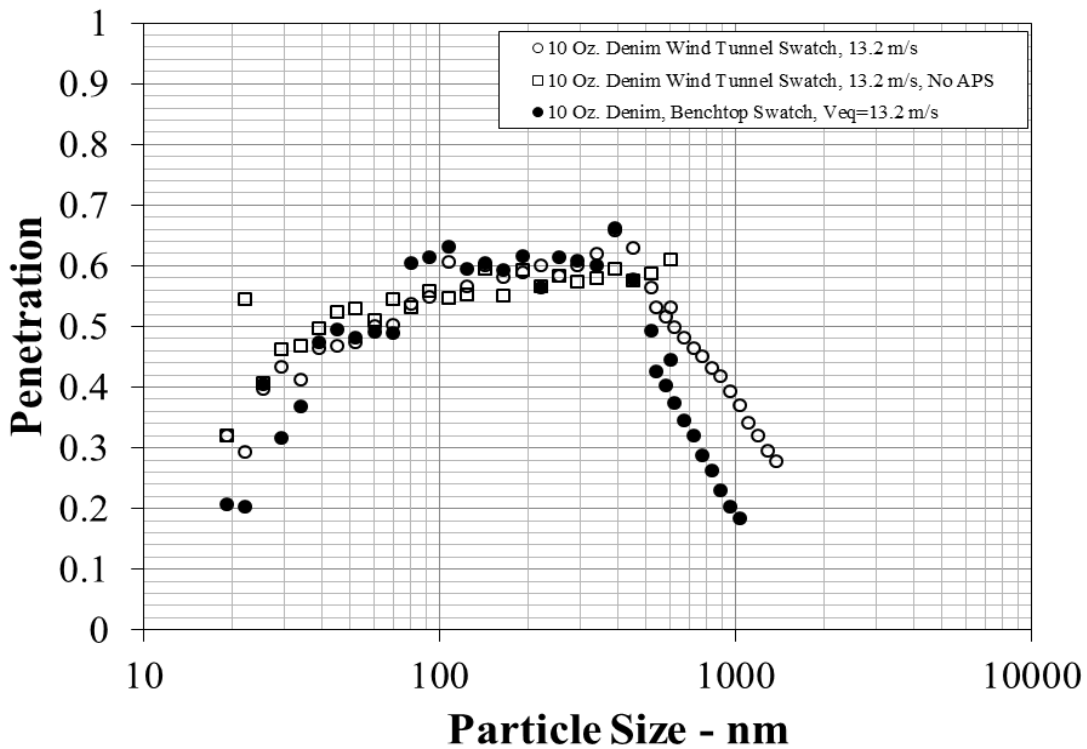

Figure A-39: Comparison of Wind Tunnel and Bench Top Swatch Results, DOS Challenge, $V_{\infty}=13.2$ m/s

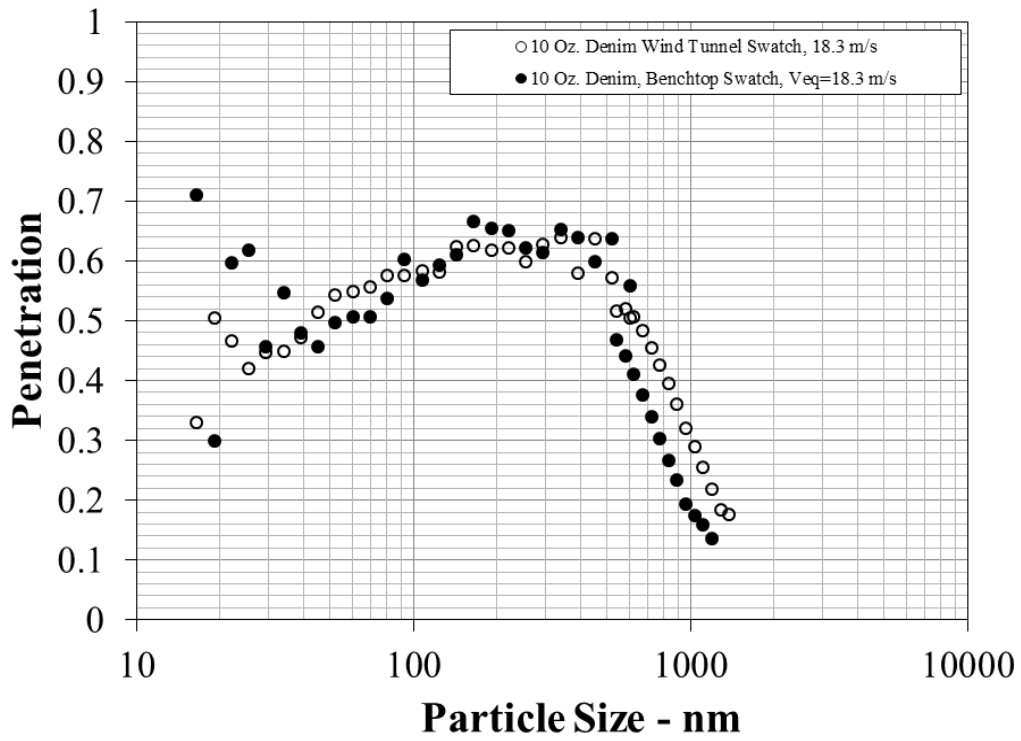

Figure A-40: Comparison of Wind Tunnel and Bench Top Swatch Results, DOS Challenge, $V_{\infty}=18.3$ m/s

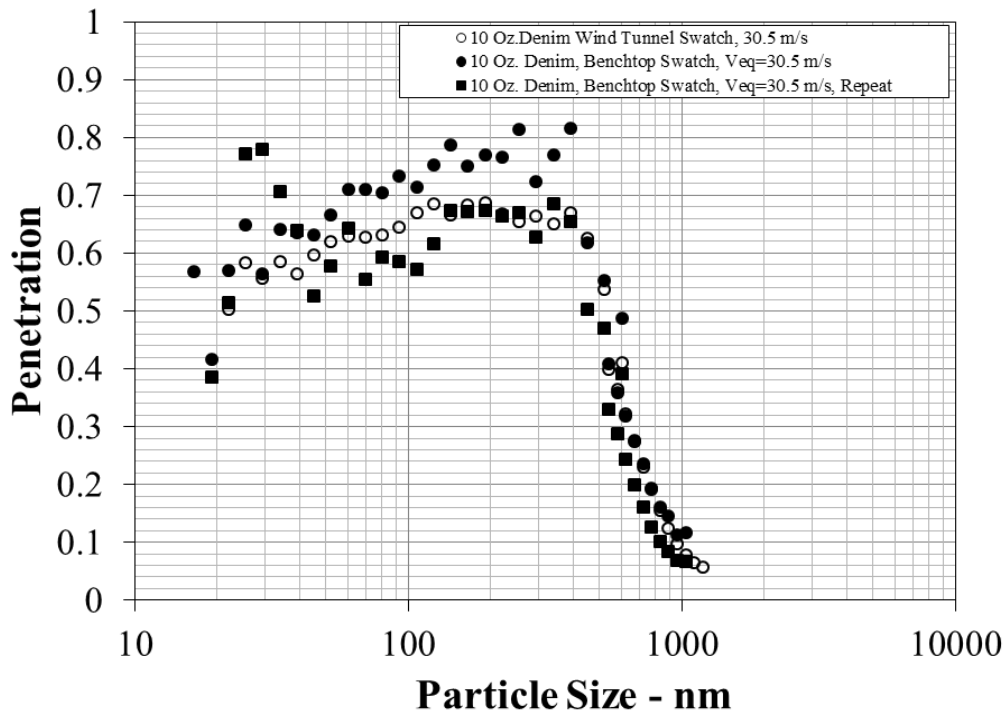

Figure A-41: Comparison of Wind Tunnel and Bench Top Swatch Results, DOS Challenge, $V_{\infty}=30.5$ m/s

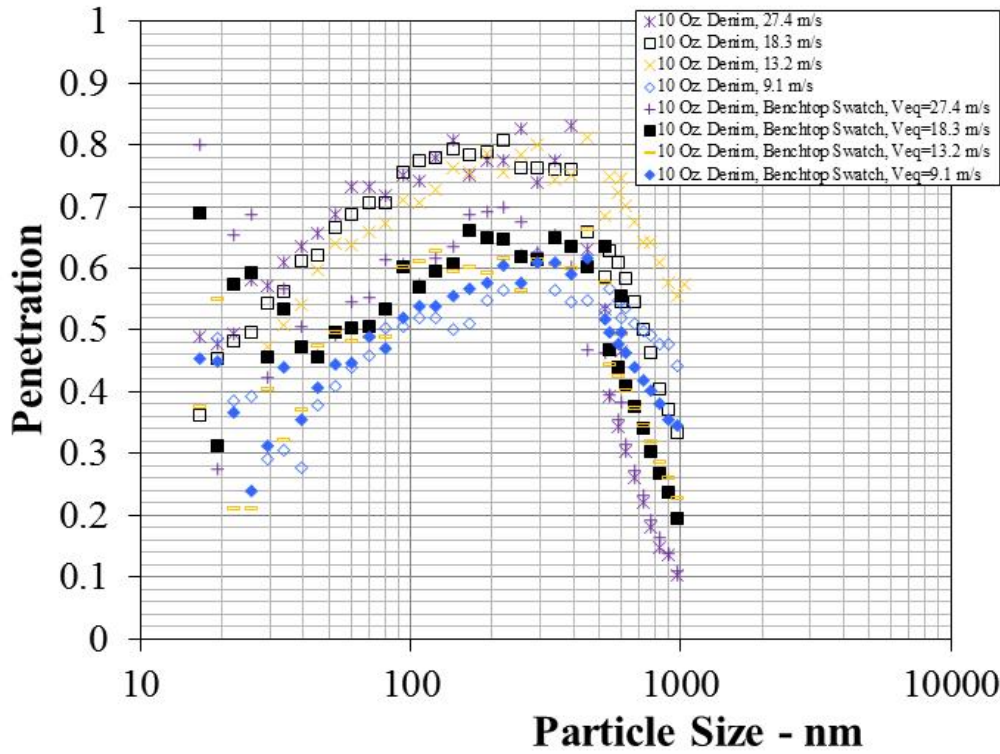

Figure A-42: Fabric Penetration Comparison between Wind Tunnel Component and Bench Top Swatch, DOS Challenge: 10 Oz. Denim

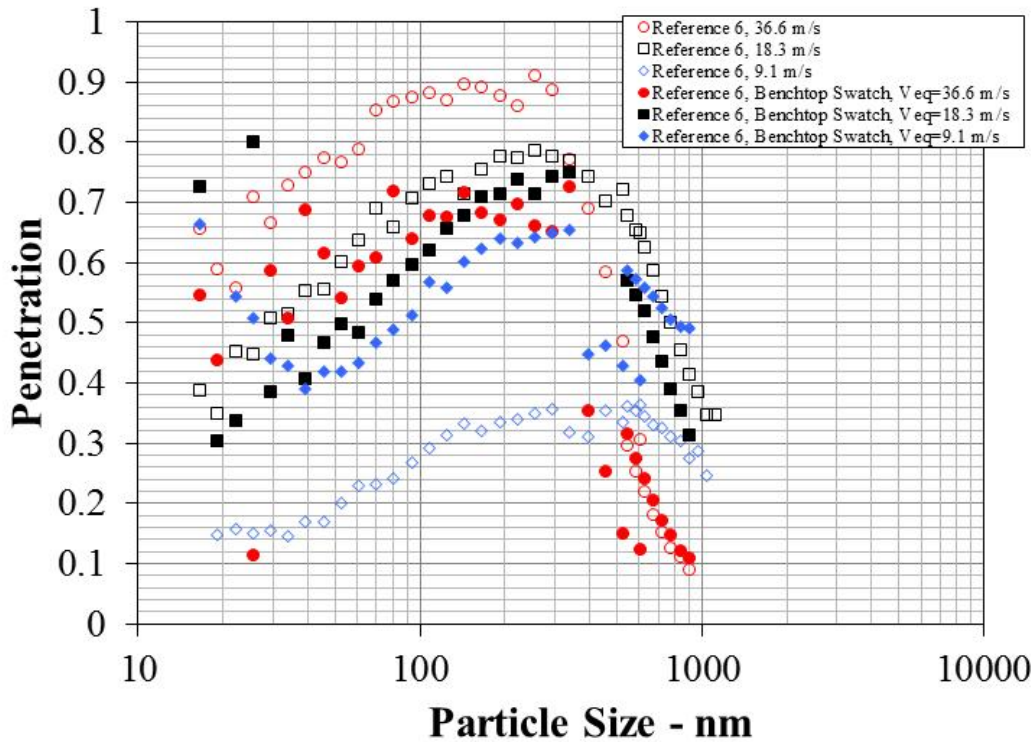

Figure A-43: Fabric Penetration Comparison between Wind Tunnel Component and Bench Top Swatch, DOS Challenge: reference 6 Material

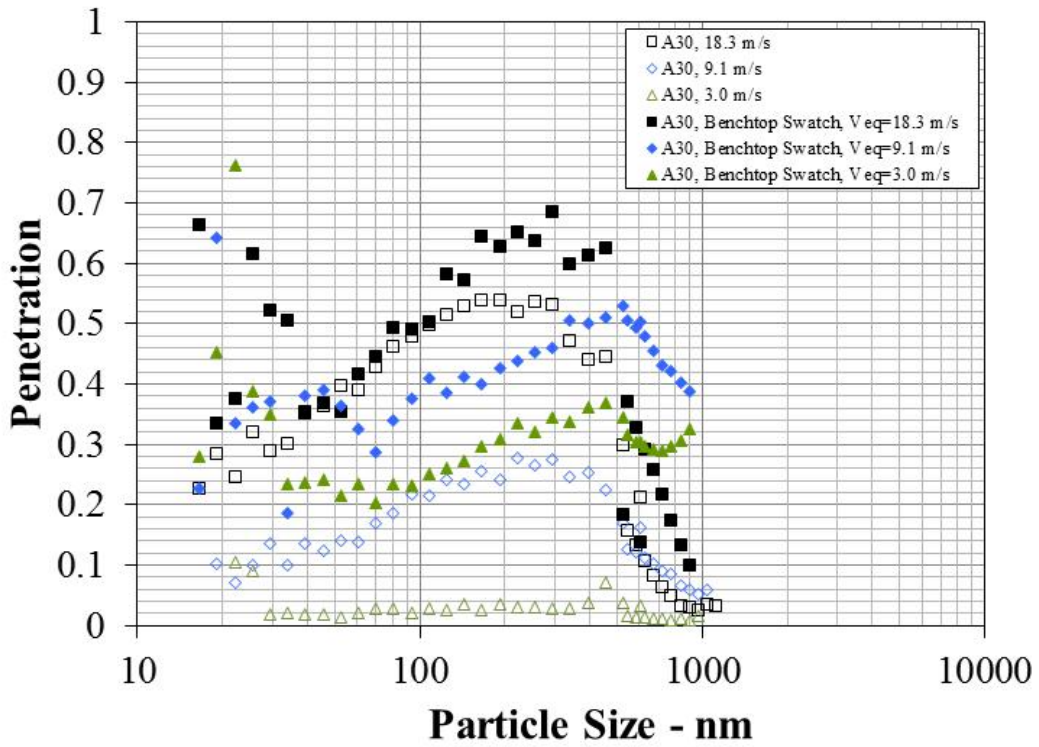

Figure A-44: Fabric Penetration Comparison between Wind Tunnel Component and Bench Top Swatch, DOS Challenge: A30

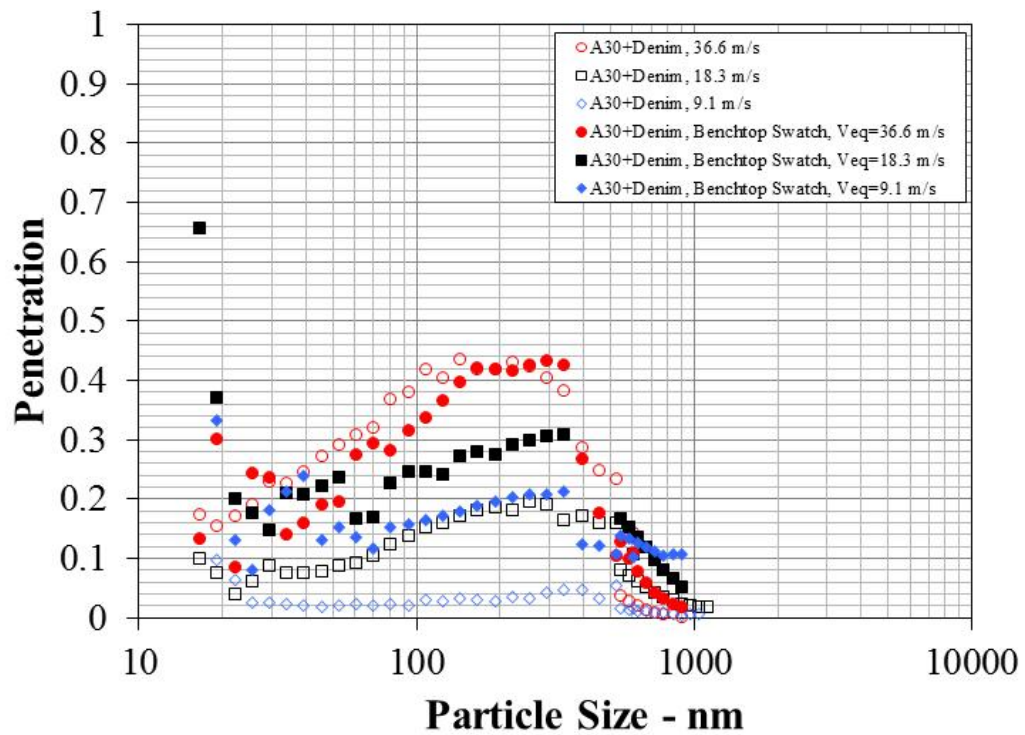

Figure A-45: Fabric Penetration Comparison between Wind Tunnel Component and Bench Top Swatch, DOS Challenge: A30 + 10 Oz. Denim

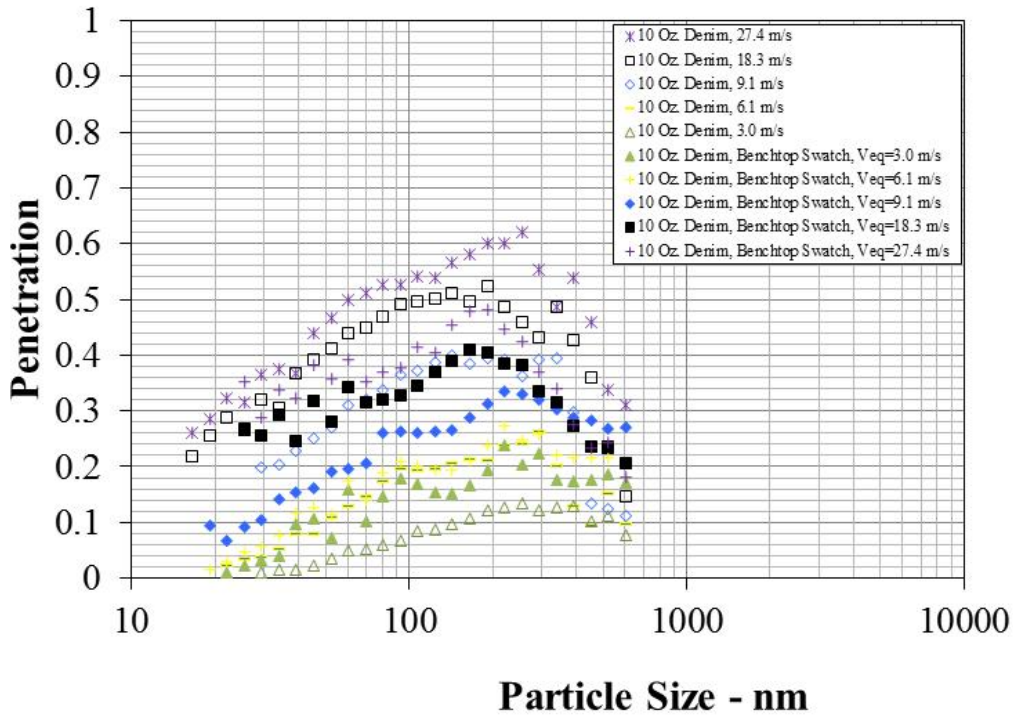

Figure A-46: Fabric Penetration Comparison between Wind Tunnel Component and Bench Top Swatch, Aerosil Challenge: 10 Oz. Denim

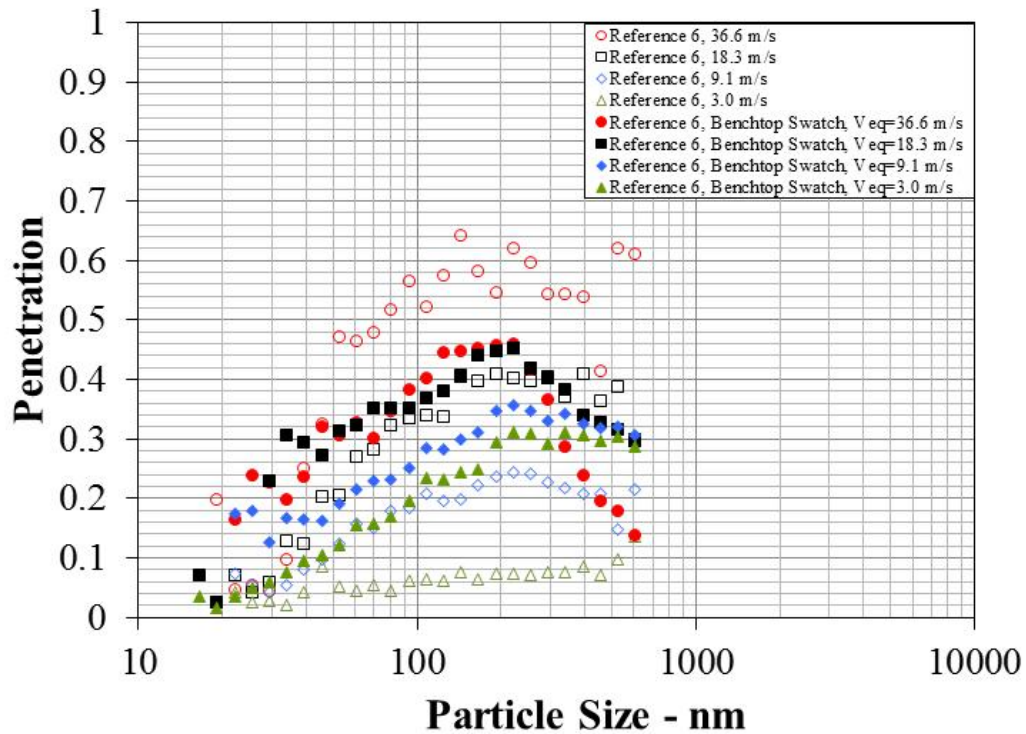

Figure A-47: Fabric Penetration Comparison between Wind Tunnel Component and Bench Top Swatch, Aerosil Challenge: reference 6 Material

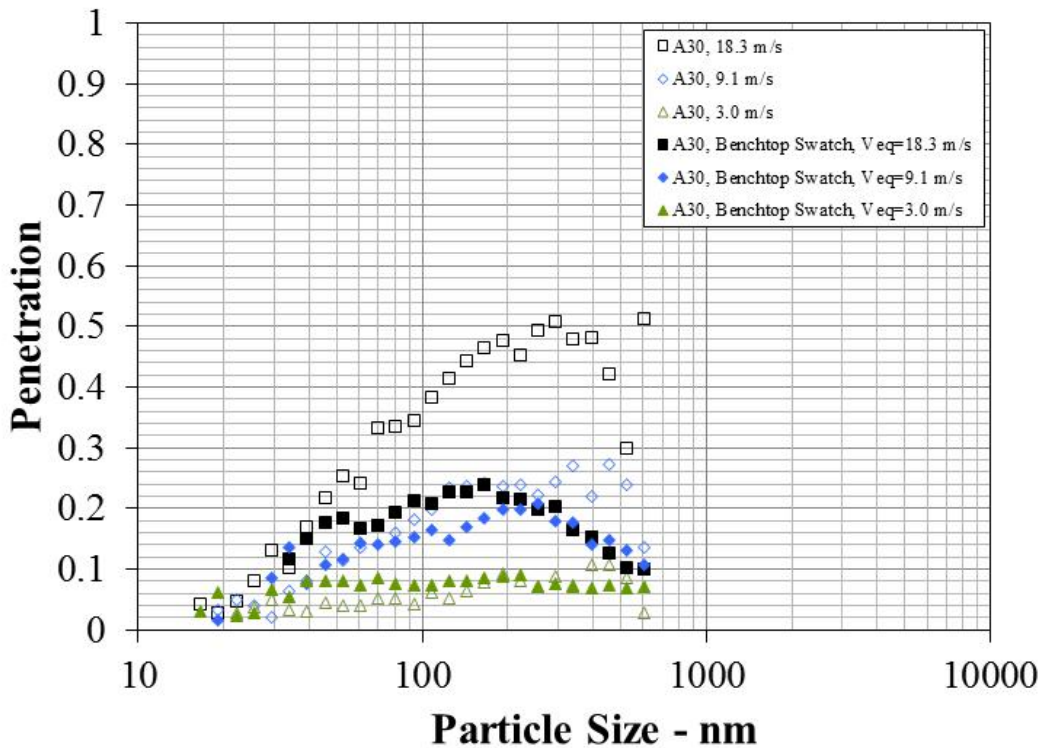

Figure A-48: Fabric Penetration Comparison between Wind Tunnel Component and Bench Top Swatch, Aerosil Challenge: A30

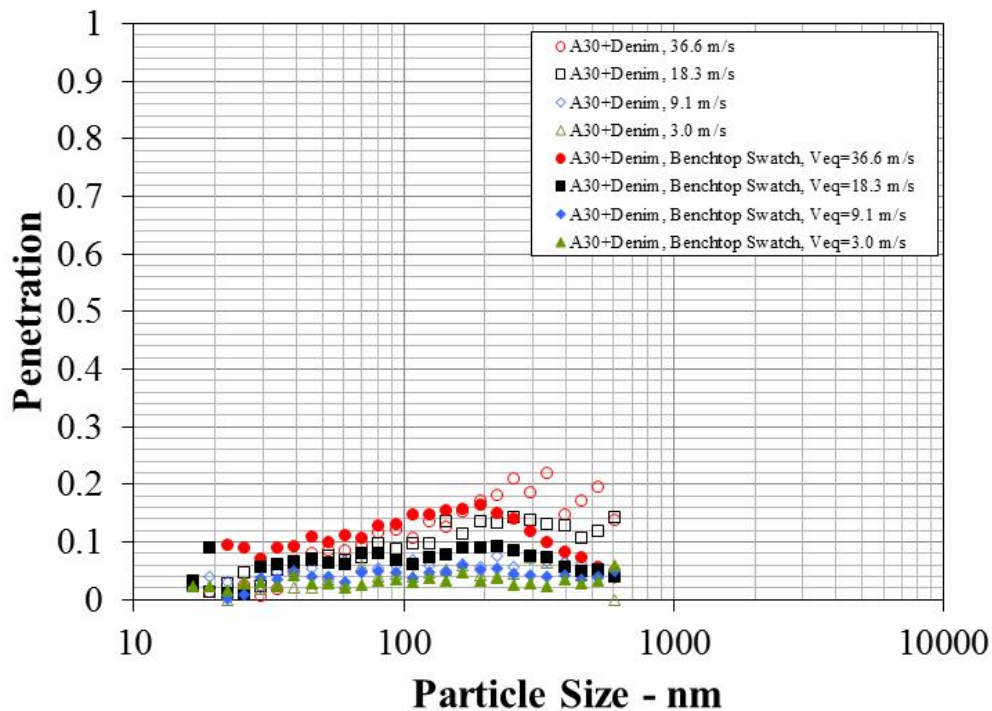

Figure A-49: Fabric Penetration Comparison between Wind Tunnel Component and Bench Top Swatch, Aerosil Challenge: A30 + 10 Oz. Denim

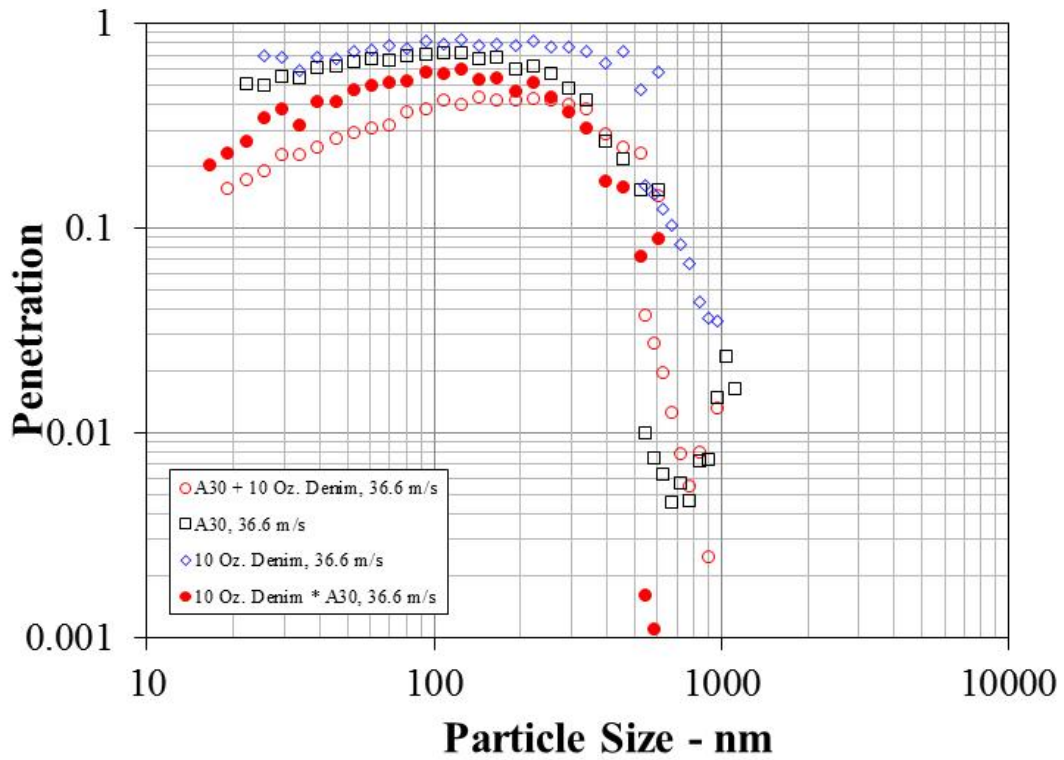

Figure A-50: Additive Effect of Fabric Penetration, Component Wind Tunnel Test, DOS Challenge: $V_{\infty} = 36.6$ m/s

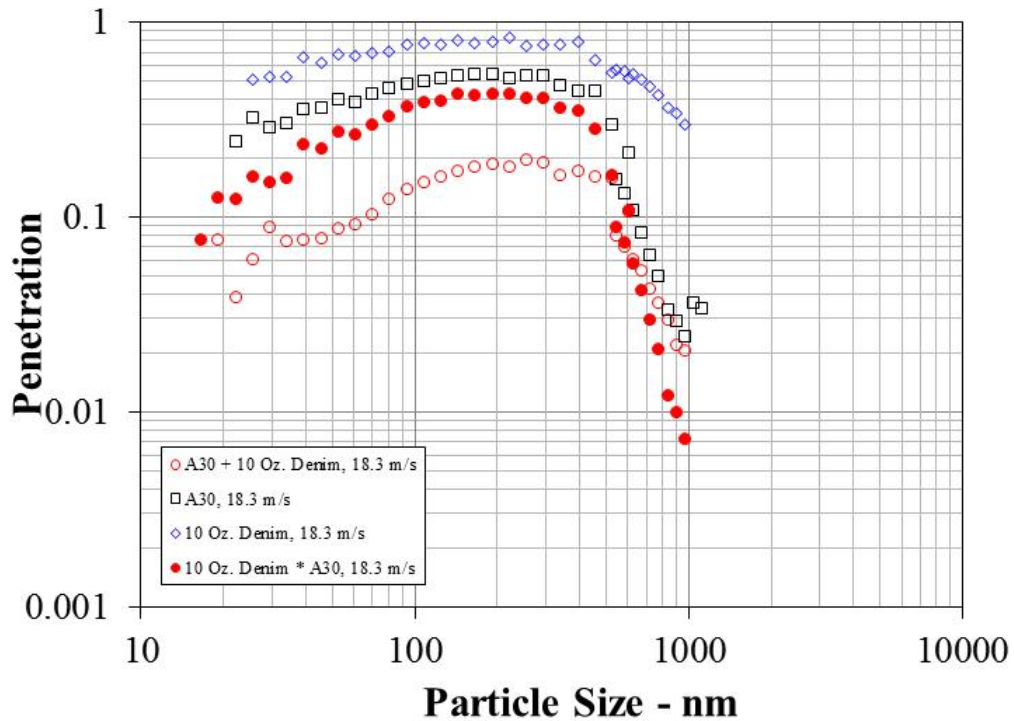

Figure A-51: Additive Effect of Fabric Penetration, Component Wind Tunnel Test, DOS Challenge: $V_{\infty} = 18.3$ m/s

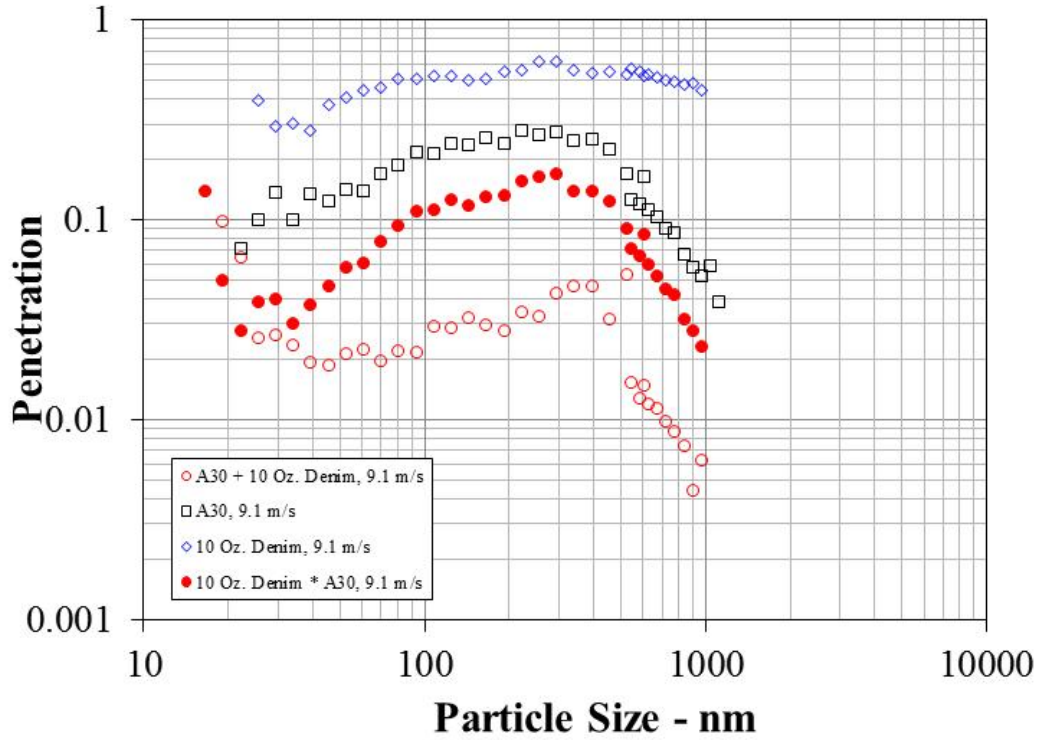

Figure A-52: Additive Effect of Fabric Penetration, Component Wind Tunnel Test, DOS Challenge: $V_{\infty} = 9.1$ m/s

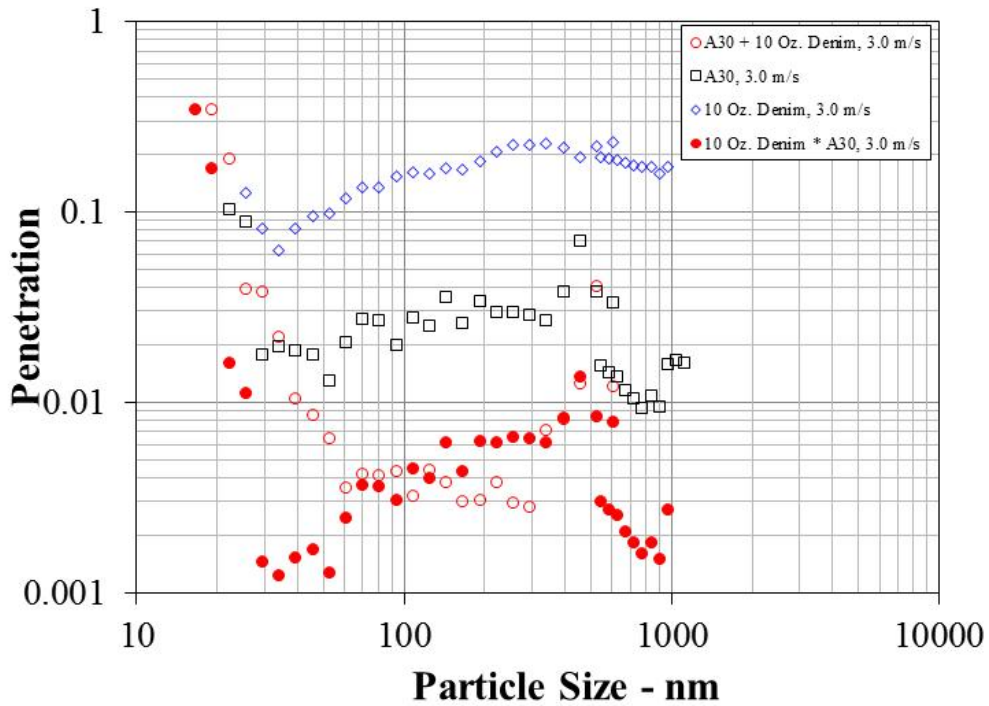

Figure A-53: Additive Effect of Fabric Penetration, Component Wind Tunnel Test, DOS Challenge: $V_{\infty} = 3.0$ m/s

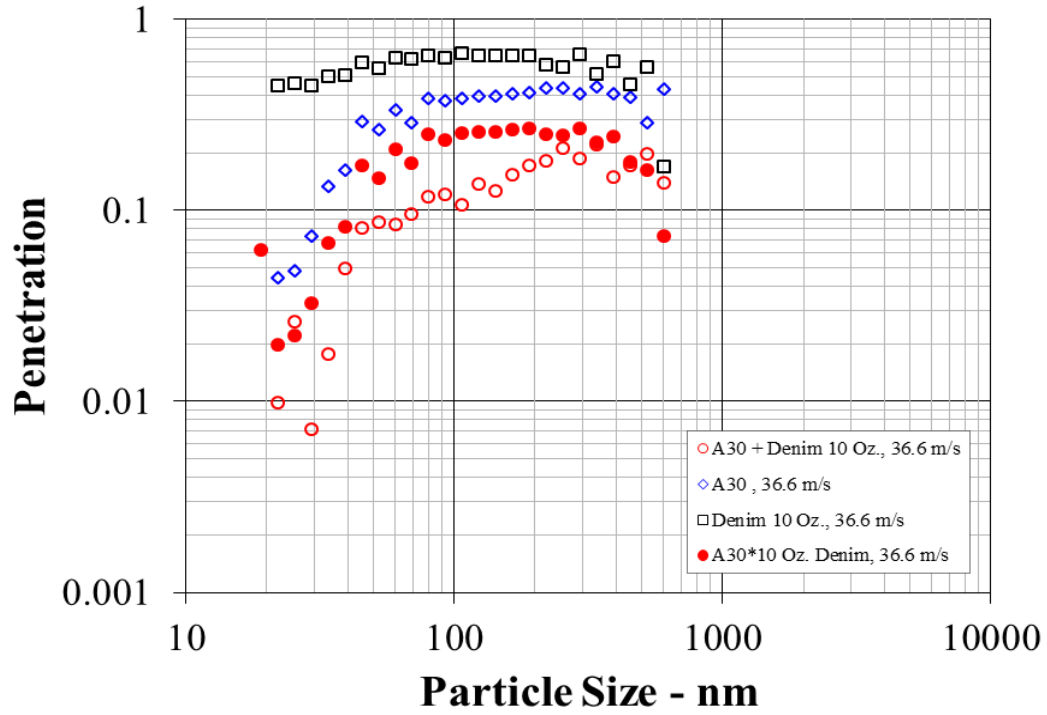

Figure A-54: Additive Effect of Fabric Penetration, Component Wind Tunnel Test, Aerosil Challenge: $V_{\infty} = 36.6$ m/s

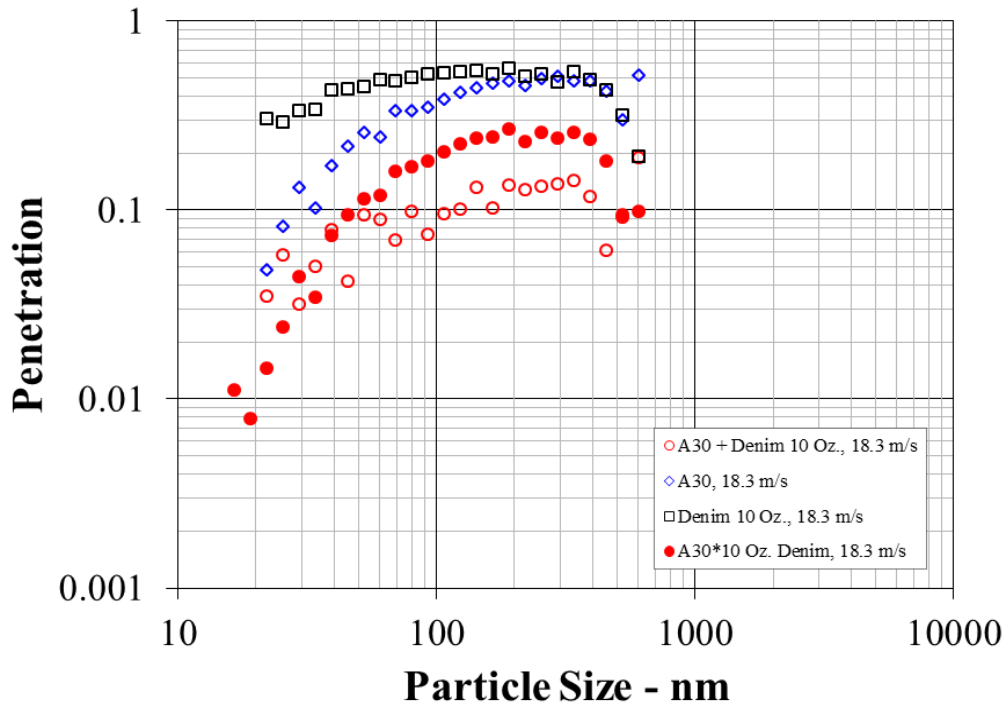

Figure A-55: Additive Effect of Fabric Penetration, Component Wind Tunnel Test, Aerosil Challenge: $V_{\infty} = 18.3$ m/s

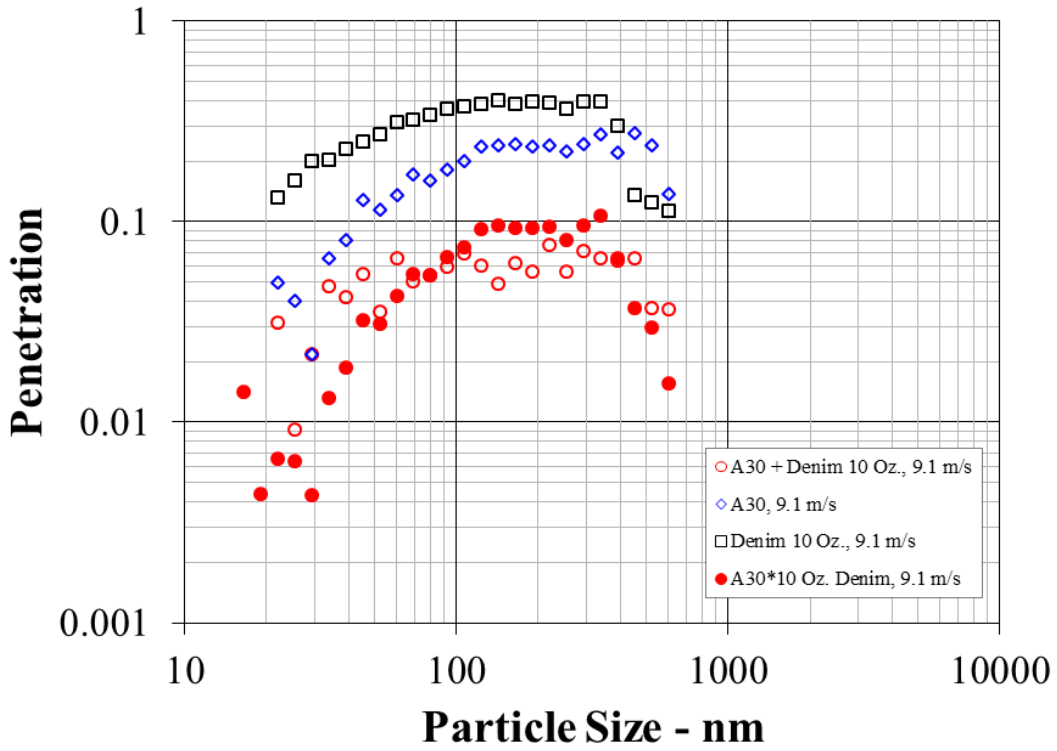

Figure A-56: Additive Effect of Fabric Penetration, Component Wind Tunnel Test, Aerosil Challenge: $V_{\infty} = 9.1$ m/s

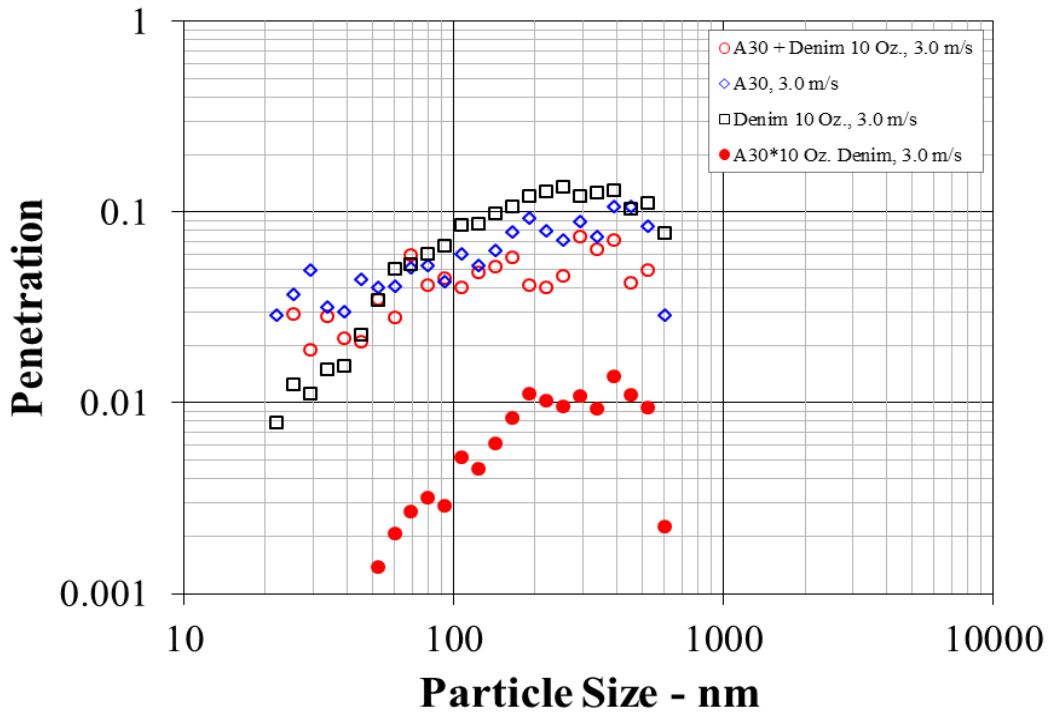

Figure A-57: Additive Effect of Fabric Penetration, Component Wind Tunnel Test, Aerosil Challenge: $V_{\infty} = 3.0$ m/s

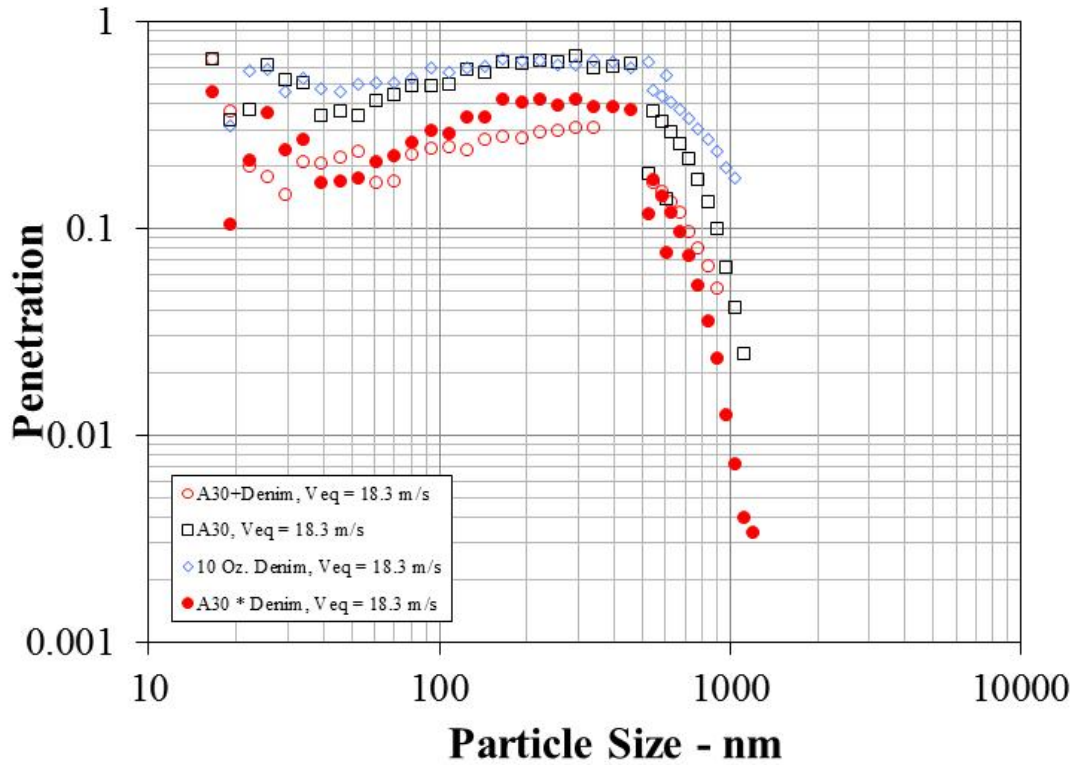

Figure A-58: Additive Effect of Fabric Penetration, Bench Top Swatch Test, DOS Challenge:
 $V_{eq} = 18.3$ m/s

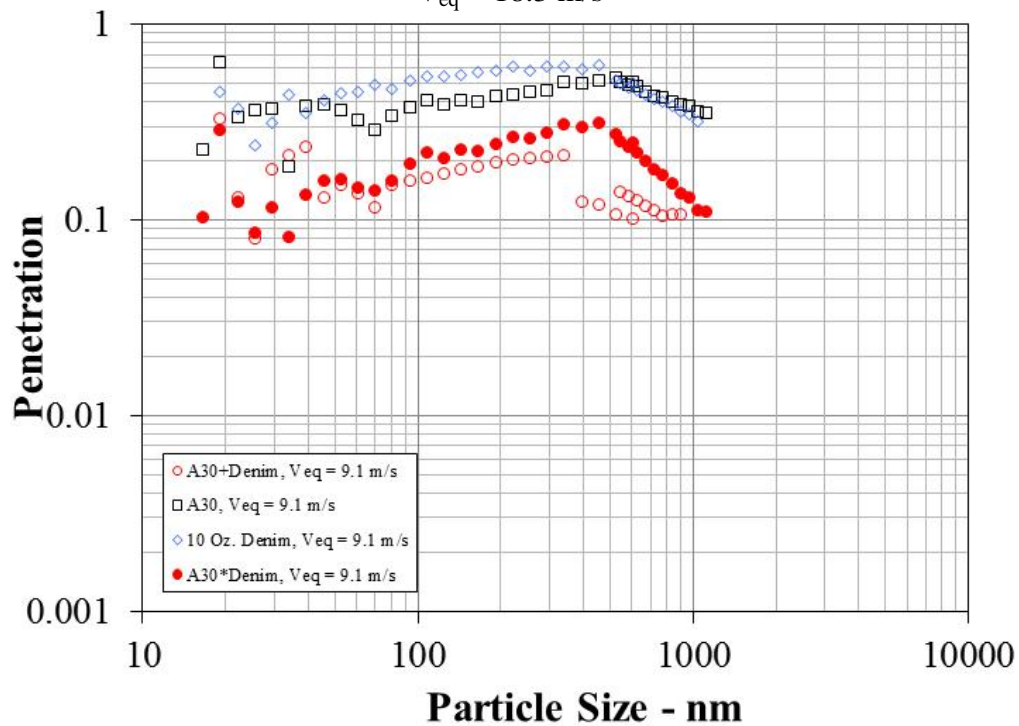

Figure A-59: Additive Effect of Fabric Penetration, Bench Top Swatch Test, DOS Challenge:
 $V_{eq} = 9.1$ m/s

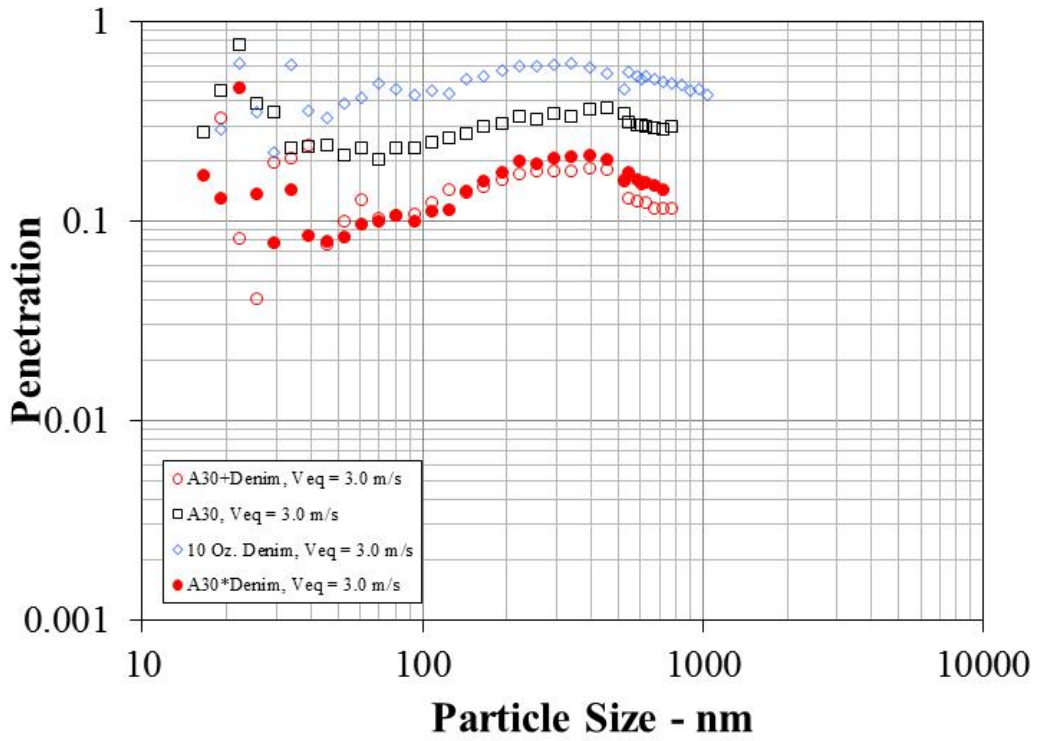

Figure A-60: Additive Effect of Fabric Penetration, Bench Top Swatch Test, DOS Challenge:
 $V_{eq} = 3.0$ m/s

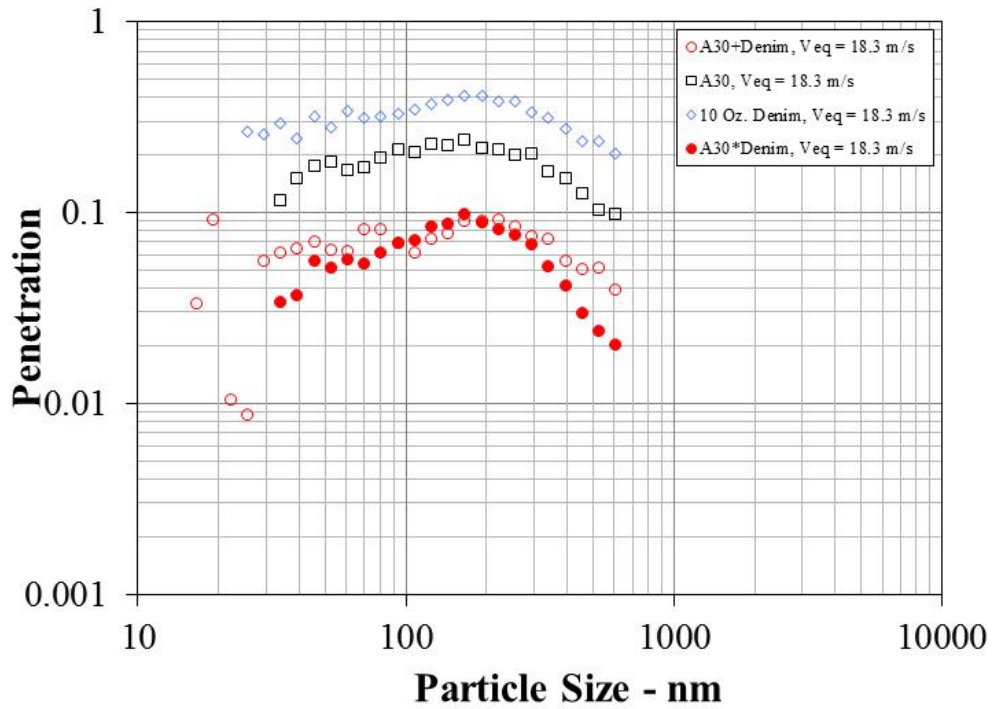

Figure A-61: Additive Effect of Fabric Penetration, Bench Top Swatch Test, Aerosil Challenge:
 $V_{eq} = 18.3$ m/s

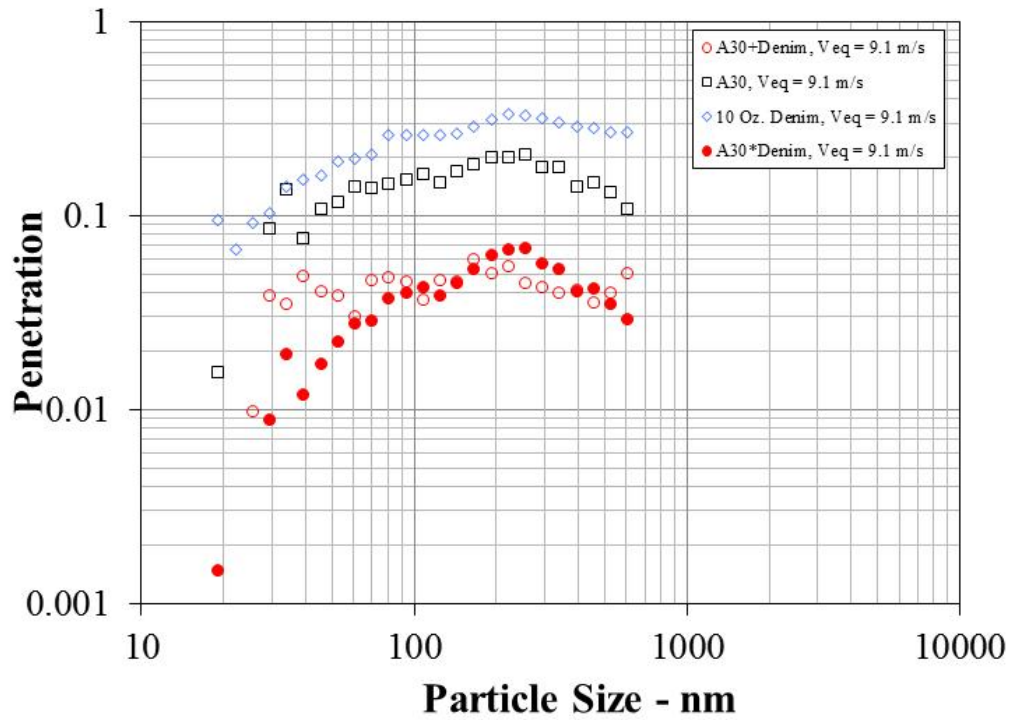

Figure A-62: Additive Effect of Fabric Penetration, Bench Top Swatch Test, Aerosil Challenge:
 $V_{eq} = 9.1 \text{ m/s}$

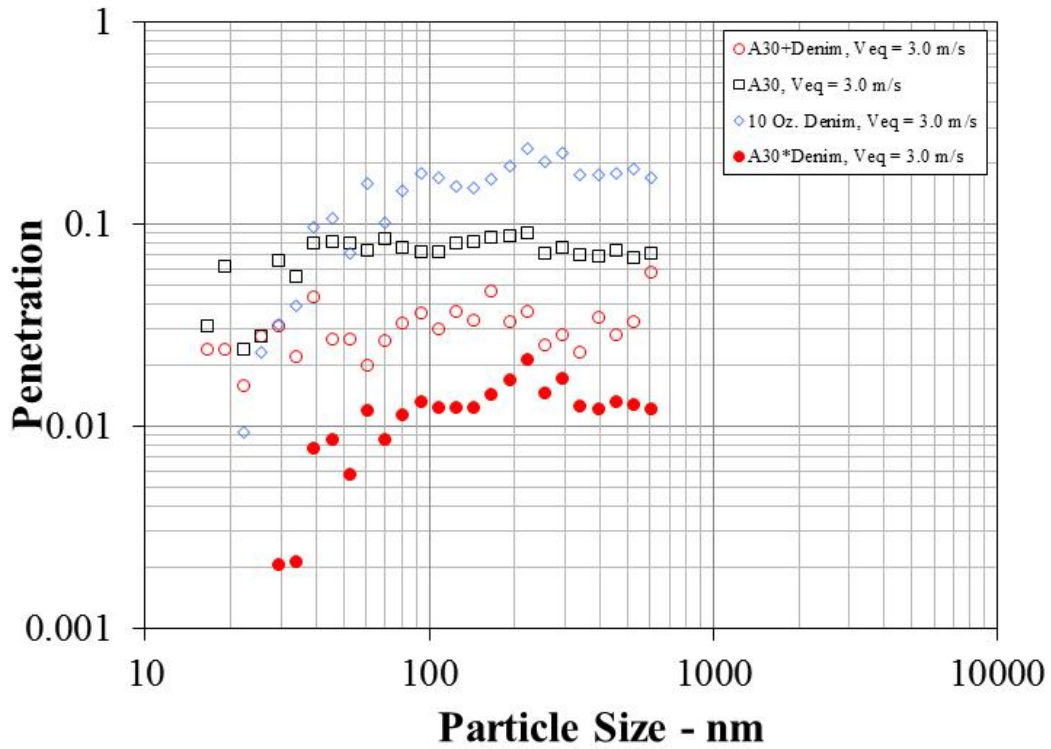

Figure A-63: Additive Effect of Fabric Penetration, Bench Top Swatch Test, Aerosil Challenge:
 $V_{eq} = 3.0 \text{ m/s}$

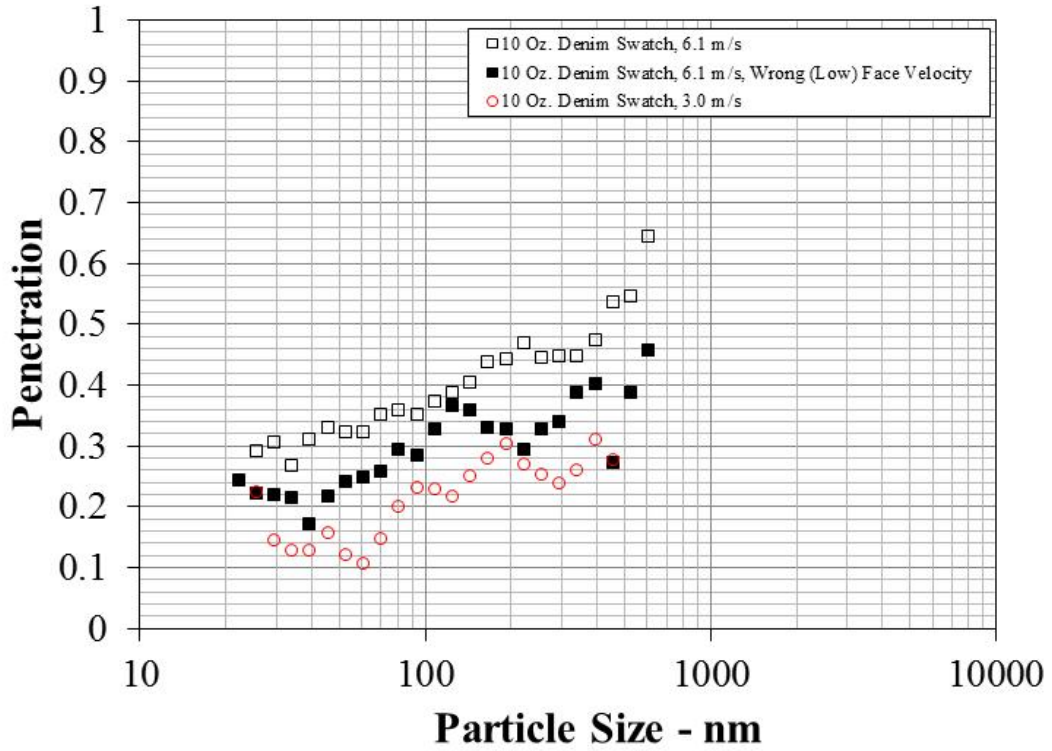

Figure A-64: Effect of Erroneous, Lower Face Velocity for Wind Tunnel Swatch

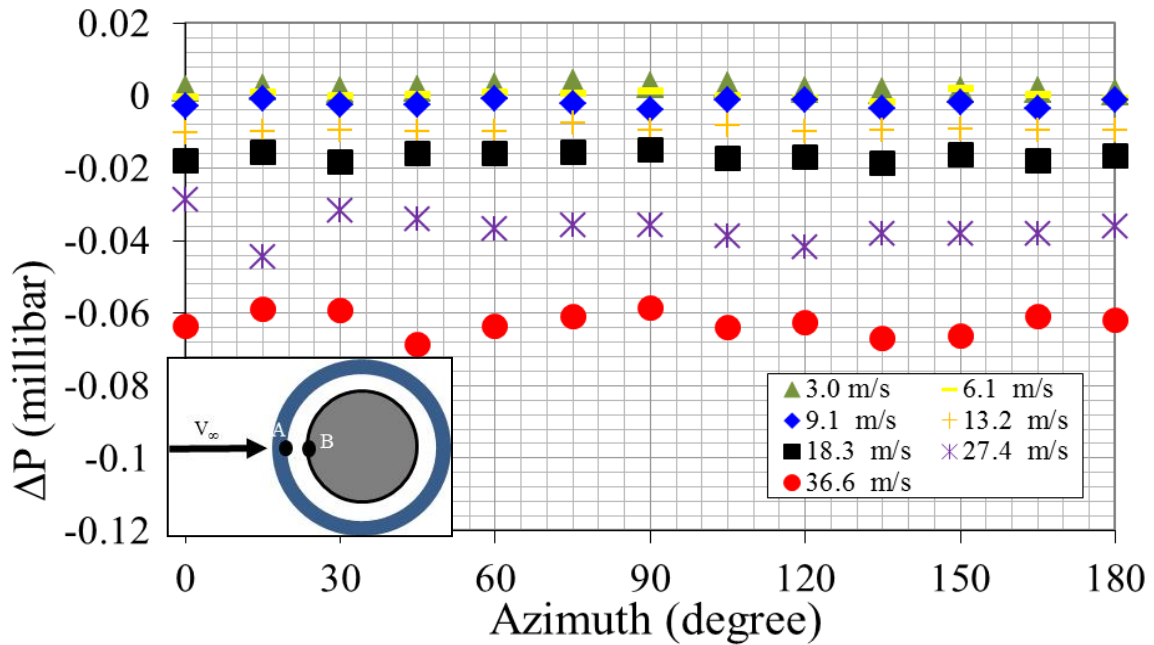

Figure A-65: Pressure Difference between Inner Cylinder Pressure Tap and Fabric Pressure on the Downstream Side of the Fabric for 10 Oz. Denim Sleeve with Screen for Various Yaw Angles

THIS PAGE INTENTIONALLY LEFT BLANK

APPENDIX B
TABLES

Table B-1: Bulk Particle Density and Size Estimates of Various Particles

Type	Density - g/ml	Std. Dev.	Peak Diameter (mean) - nm	Diameter Std. Dev. - nm
Aerosil 380 - Untagged	0.0450	0.0038	108	34
Aerosil 380 - Tagged	0.1082	0.0062	70	10
Cabosil - Untagged	0.0330	0.0021	109	22
Cabosil - Tagged v1	0.1041	0.0051	75	28
Cabosil - Tagged v2	0.1025	0.0030	NA	NA
Syloid 244 - Untagged	0.1226	0.0033	1040	NA
Glass Bead	0.9444	0.0456	NA	NA
Arizona Road Dustr	0.8072	0.1084	NA	NA
DOS	0.9140	NA	106	5

Table B-2: Instrumentation Settings

SMPS:	
Charge Correction	On
t_d (Delay Time)	3.3 s
Impactor	0.0457 cm
DMA	3081
CPC Model	3025A
CPC Flow	Low
Up scan	120 s
Down Scan	15 s
Sheath Flow	3 lpm
Aerosol Flow	0.3 lpm
Low Voltage	10 V
High Voltage	9630 V
Size Range	14.3 nm to 673 nm
t_f	7.4 s
D50	678 nm
APS:	
Dilution/Efficiency File	00100to1.e20
Particle Density (DOS)	0.914 g/cc
Stokes Correction	On
Channel	<0.523 to 20.535 micron
Sample Time	120 s
Summation	Channel and Raw data

Table B-3: Fabric Permeability Data

Material	Average Permeability (cm/s)	Standard Deviation (cm/s)	Number of Samples
10 Oz. Denim	3.1259	0.1697	26
A30	7.6193	0.6498	18
A30 + 10 Oz. Denim	2.5212	0.1731	15
Donaldson Dura-Life	10.0008	0.4479	14
Cotton Twill	8.4824	1.4392	16
Donaldson PTFE	5.0336	NA	1

Legend for Tables B-4 to B-7

Δ% Difference
Above 20%
Between 10% & 20%
Between 5% & 10%
Below 5%

Table B-4: Component Data Comparison to Bench Top Swatch Data, DOS Challenge

DOS	Velocity (m/s)						
	3	6.1	9.1	13.2	18.3	27.4	36.6
10 Oz. Denim	NA - Extrapolated	NA - Extrapolated					NA - Extrapolated
A30		NA		NA		NA	NA - Extrapolated
A30 + 10 Oz. Denim	NA - Extrapolated	NA		NA		NA	
Reference 6 Fabric	NA - Extrapolated	NA		NA		NA	

Table B-5: Component Data Comparison to Bench Top Swatch Data, Aerosil Challenge

Aerosil	Velocity (m/s)						
	3	6.1	9.1	13.2	18.3	27.4	36.6
10 Oz. Denim				NA			NA - Extrapolated
A30		NA		NA		NA	NA - Extrapolated
A30 + 10 Oz. Denim		NA		NA		NA	
Reference 6 Fabric		NA		NA		NA	

Table B-6: Comparison of A30 + 10 Oz. Denim Combined to Individual Component Penetration (A30*10 Oz. Denim), Wind Tunnel Tests

Wind Tunnel	Velocity (m/s)			
A30/Denim Difference	3	9.1	18.3	36.6
DOS				
Aerosil				

Table B-7: Comparison of A30 + 10 Oz. Denim Combined to Individual Component Penetration (A30*10 Oz. Denim), Bench Top Tests

Bench Top	Velocity (m/s)			
A30/Denim Difference	3	9.1	18.3	36.6
DOS				NA - Extrapolated
Aerosil				NA - Extrapolated

THIS PAGE INTENTIONALLY LEFT BLANK

DISTRIBUTION:

NAVAIRWARCENACDIV (4.3.2.1/T. Ghee), Bldg. 2187, Room 1320 (10)
48110 Shaw Road, Patuxent River, MD 20670-1906

Defense Threat Reduction Agency, JSTO CB/CBT (C. Bass) (5)
8725 John J. Kingman Road, Ft. Belvoir, VA 22060-6201
Charles.bass@dtra.mil

U.S. Army NSRDEC, RDNS-WSC-C (S. F. Zopf), Bldg. 4, Room D114 (3)
15 Kansas Street, Natick, MA 01760
Stephanie.f.zof.civ@mail.mil

NAVAIRWARCENACDIV (4.12.6.2), Bldg. 407, Room 116 (1)
22269 Cedar Point Road, Patuxent River, MD 20670-1120

DTIC (1)
8725 John J. Kingman Road, Suite 0944, Ft. Belvoir, VA 22060-6218

UNCLASSIFIED

UNCLASSIFIED