

Range Reference Notebook

15 October 2006

B.E. Smith
R.S. Wassmann
Col (Ret.) W. R. Wright
J. K. Miller

Customer: SERDP/ESTCP

Contract No.: FA8903-04-D-8715-0021

Dept. No.: H050

Project No.: 0604339W-BB

©2006 Mitretek Systems



**Center for Science and Technology
Falls Church, Virginia**

Report Documentation Page

Form Approved
OMB No. 0704-0188

Public reporting burden for the collection of information is estimated to average 1 hour per response, including the time for reviewing instructions, searching existing data sources, gathering and maintaining the data needed, and completing and reviewing the collection of information. Send comments regarding this burden estimate or any other aspect of this collection of information, including suggestions for reducing this burden, to Washington Headquarters Services, Directorate for Information Operations and Reports, 1215 Jefferson Davis Highway, Suite 1204, Arlington VA 22202-4302. Respondents should be aware that notwithstanding any other provision of law, no person shall be subject to a penalty for failing to comply with a collection of information if it does not display a currently valid OMB control number.

1. REPORT DATE 15 OCT 2006	2. REPORT TYPE	3. DATES COVERED 00-00-2006 to 00-00-2006			
4. TITLE AND SUBTITLE Range Reference Notebook		5a. CONTRACT NUMBER			
		5b. GRANT NUMBER			
		5c. PROGRAM ELEMENT NUMBER			
6. AUTHOR(S)		5d. PROJECT NUMBER			
		5e. TASK NUMBER			
		5f. WORK UNIT NUMBER			
7. PERFORMING ORGANIZATION NAME(S) AND ADDRESS(ES) Mitretek Systems, Center for Science and Technology, 3150 Fairview Park Drive, Falls Church, VA, 22042		8. PERFORMING ORGANIZATION REPORT NUMBER			
9. SPONSORING/MONITORING AGENCY NAME(S) AND ADDRESS(ES)		10. SPONSOR/MONITOR'S ACRONYM(S)			
		11. SPONSOR/MONITOR'S REPORT NUMBER(S)			
12. DISTRIBUTION/AVAILABILITY STATEMENT Approved for public release; distribution unlimited					
13. SUPPLEMENTARY NOTES					
14. ABSTRACT					
15. SUBJECT TERMS					
16. SECURITY CLASSIFICATION OF:			17. LIMITATION OF ABSTRACT Same as Report (SAR)	18. NUMBER OF PAGES 236	19a. NAME OF RESPONSIBLE PERSON
a. REPORT unclassified	b. ABSTRACT unclassified	c. THIS PAGE unclassified			

Table of Contents

SECTION 1 - INTRODUCTION	1-1
1.1 Background	1-1
1.2 Objectives	1-2
1.3 Approach and Methodology	1-3
1.3.1 Identify Sources of Data and Information	1-3
1.3.2 Review Information	1-3
1.3.3 Develop and Present the Information	1-3
1.4 Report Layout	1-4
SECTION 2 - Site Information	2-1
2.1 Physical Characteristics	2-1
2.2 Factors Controlling MEC Distribution and Depth	2-3
SECTION 3 - Direct-Fire Ranges	3-1
3.1 General Description	3-1
3.2 Factors Controlling MEC Distribution	3-10
3.3 MEC Distribution	3-11
SECTION 4 - Indirect-Fire Ranges	4-1
4.1 General Description	4-1
4.2 Factors Controlling MEC Distribution	4-3
4.3 MEC Distribution	4-9
SECTION 5 - Bombing and Gunnery Ranges	5-1
5.1 General Description	5-1
5.2 Factors Controlling MEC Distribution	5-9
5.3 MEC Distribution	5-9
SECTION 6 - References	6-1
6.1 Reference Documents	6-1
6.2 Additional Technical and Guidance References and Websites	6-5
ACRONYMS	ACR-1
GLOSSARY	GL-1
Appendix A— Direct Fire Range Examples	A-1
Appendix B— Indirect Fire Range Examples	B-1
Appendix C— Bombing and Gunnery Range Examples	C-1
Appendix D— Standard Range Designs	D-1
Appendix E— Ordnance Images	E-1

List of Figures

Figure	Page
Figure 1-1. Relationship between Ranges and the Base or Installation	1-1
Figure 1-2. Relationship between MRAs and MRSs on a Range	1-2
Figure 2-1. Conceptual Surface Danger Zone (SDZ) for Direct Fire Weapons System	2-4
Figure 2-2. Theoretical Range Complex with Multiple Weapon Systems	2-5
Figure 2-3. Penetration Angle and Correlation to Depth of Penetration	2-5
Figure 2-4. Projectile Penetration Depths	2-6
Figure 2-5. “11x” Formula Plot	2-7
Figure 2-6. Performance of Selected Detection Systems at the APG Open-Field Standard Test Site (100% Detection Depth and Max Detection Depth)	2-8
Figure 2-6. Performance of Selected Detection Systems at APG Open-Field Standard Test Site (100% Detection Depth and Max Detection Depth) (Concluded)	2-9
Figure 3-1. Armored Personnel Carrier in Place for Use as Target	3-2
Figure 3-2. Standard Rifle Grenade/Anti-Tank Rocket SDZ	3-3
Figure 3-3. Standard Recoilless Rifle Range	3-4
Figure 3-4. Standard Direct Fire Range Diagrams	3-6
Figure 3-4. Standard Direct Fire Range Diagrams (Concluded)	3-7
Figure 3-5. Effect of Terrain on MEC Location and Size for a Direct Fire Recoilless Rifle Range	3-11
Figure 3-6. Direct Fire Range, Cross Section Example	3-11
Figure 3-7. Example of Direct Fire Range at Fort Ritchie Showing MEC Distribution	3-13
Figure 4-1. Typical Trajectory of Indirect Fire Weapons	4-1
Figure 4-2. Mortar Range SDZ	4-2
Figure 4-3. Standard Indirect Fire Range Diagrams	4-4
Figure 4-4. Example of Artillery Range at Badlands Bombing Range Showing MEC Distribution in Impact Area	4-9
Figure 5-1. Bombing Target, Falcon Range, Fort Sill, Oklahoma	5-1
Figure 5-2. Standard Bombing and Gunnery Range Diagrams	5-4
Figure 5-3. Example of Bombing Range MEC Anomaly Distribution, MTADS Survey of Pueblo of Laguna Target N-10	5-10

List of Tables

Table	Page
Table 3-1. Direct Fire Ranges and Probable Ordnance Types (WWII Era)	3-5
Table 3-2. Range Examples – Direct Fire	3-8
Table 3-2. Range Examples – Direct Fire (Concluded)	3-9
Table 3-3. Theoretical Penetration Depths for Direct-Fire Ordnance	3-13
Table 4-1. Indirect Fire Ranges and Probable Ordnance Types (WWII Era)	4-3
Table 4-2. Range Examples – Indirect Fire	4-5
Table 4-2. Range Examples – Indirect Fire (Continued)	4-6
Table 4-2. Range Examples – Indirect Fire (Concluded)	4-7
Table 4-3. Theoretical Penetration Depth for Indirect Fire Ordnance	4-8
Table 5-1. Bombing Ranges and Probable Ordnance Types (WWII Era)	5-3
Table 5-2. Range Examples – Bombing and Gunnery	5-5
Table 5-2. Range Examples – Bombing and Gunnery (Continued)	5-6
Table 5-2. Range Examples – Bombing and Gunnery (Continued)	5-7
Table 5-2. Range Examples – Bombing and Gunnery (Concluded)	5-8
Table 5-3. Theoretical Penetration Depths for Air-Delivered Ordnance	5-9

SECTION 1 - INTRODUCTION

1.1 Background

The [Strategic Environmental Research and Development Program \(SERDP\)](#) and [Environmental Security Technology Certification Program \(ESTCP\)](#) tasked Mitretek Systems to develop reference information on the characteristics of munitions response areas (MRAs) and munitions response sites (MRSs). An MRA is an area, such as a former range or a munitions burial site, that may contain unexploded ordnance (UXO), discarded military munitions, or munitions constituents with explosive properties (collectively called munitions and explosives of concern [MEC]). An MRA may contain one or more MRSs. These areas typically occur on parcels of land that were once training ranges (see Figure 1-1). An MRS is a discrete location within an MRA that is known to require a munitions response (MR). The relationship between an MRA and an MRS on a range is shown in Figure 1-2. A more complete description of these areas and materials can be found in the list of definitions at the end of the report.

The report provides background information on the characteristics of MRAs and MRSs, and provides examples of how these areas and sites were investigated and remediated. This information can be used by program managers to help them develop safe and cost-effective MEC characterization and remediation programs.

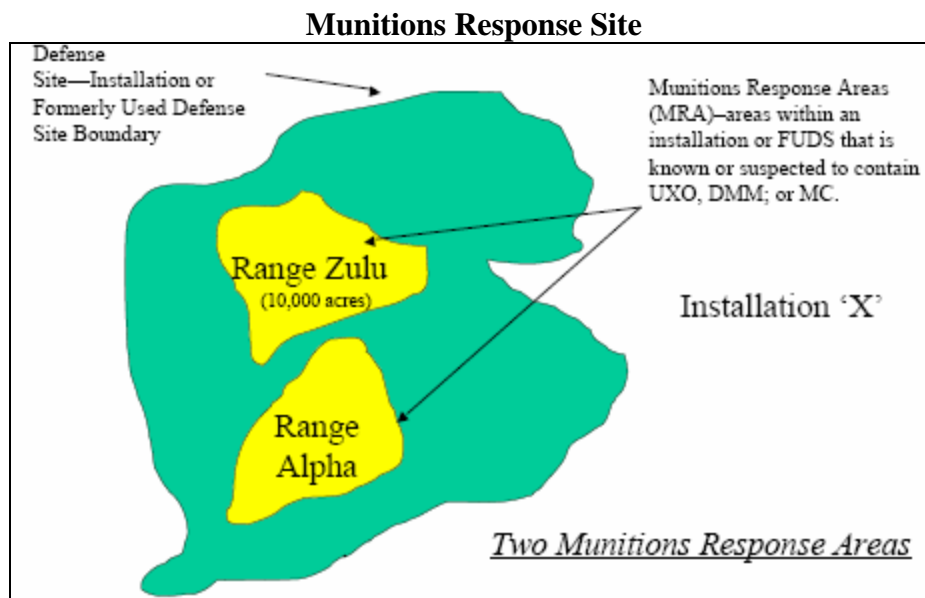

Source: Selstrom, 2003

Figure 1-1. Relationship between Ranges and the Base or Installation

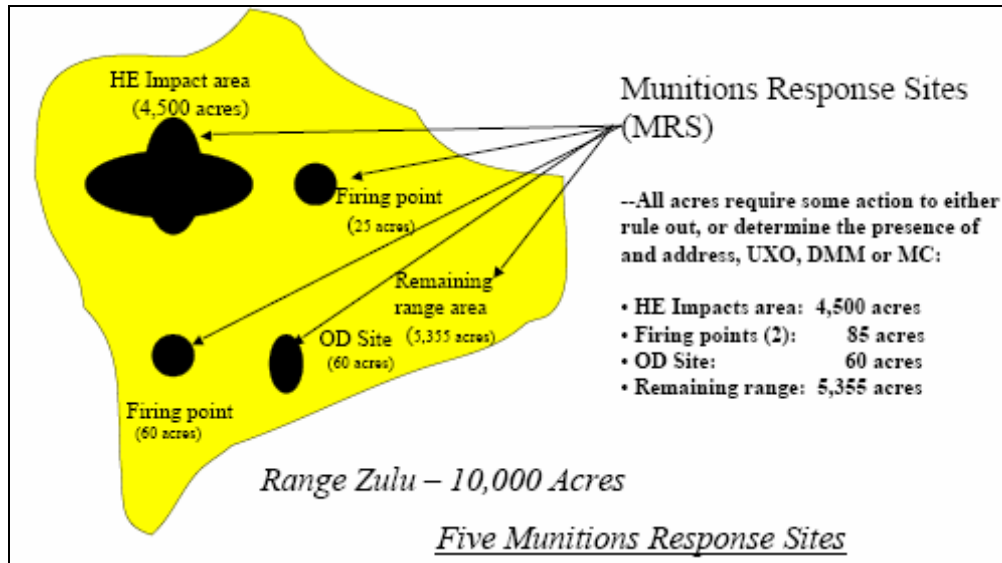

Source: Selstrom, 2003

Figure 1-2. Relationship between MRAs and MRSs on a Range

MEC is a relatively new term; in 2003, it replaced ordnance and explosives (OE) as the new “umbrella term.” MEC includes those military munitions that pose an explosive safety risk and consists of three types of military munitions:

- Unexploded ordnance (UXO)—Fired military munitions (10 U.S.C. 2710 [e][9])
- Discarded military munitions (DMM)—Munitions abandoned without proper disposal (10 U.S.C. 2710 [e][2])
- Munition constituents—Explosive materials that if present at sufficient concentration in a soil may constitute an explosive hazard (e.g., TNT greater than 10 percent).

Munitions are designed to damage, destroy, or kill a military target under a very broad range of operating conditions. Many munitions undergo extreme stresses during firing and at impact (heat, pressure, and velocity). While munitions always pose a danger, those that have been fired and fail to properly function (e.g., UXO) are much more dangerous and pose a severe hazard. UXO can function even after extended periods between use and recovery. Certain rocket fuzes are extremely sensitive and may function with little disturbance, and rocket fragments may travel more than 60 meters (200 feet). Although not applicable to old ranges, some of the more modern munitions do not require physical disturbance in order to detonate. These newer types of munitions, once armed, may be detonated by radio waves or other forms of electromagnetic signals. Thus, identification and removal of MEC is a critical step in remediating former ranges.

1.2 Objectives

The objective of this project is to develop reference information—this report, an associated database, and a list of references—on site characteristics at closed ranges and to make it available to technology developers or program managers working in the field of UXO site characterization. This report provides these individuals and their respective organizations with data that will allow them to learn about MRA and MRS characteristics, perform program

planning, or conduct a requirements analysis prior to going to the field and collecting their own information. The report can assist in the development of a conceptual site model (CSM)—a planning tool that integrates site information from a variety of sources. The CSM can be used to help evaluate the information with respect to project objectives and data needs. In addition, because no two sites are alike, examples from actual ranges are provided in Appendixes A, B, and C to demonstrate the variability that makes UXO site characterization unique and difficult.

Note: It is important to remember that the range, MRA, and MRS examples shown in this report have *all* previously undergone some type of UXO clearance, perhaps more than once; thus, the examples shown do not represent sites prior to any UXO clearance.

1.3 Approach and Methodology

1.3.1 Identify Sources of Data and Information

This information was derived primarily from ranges at Formerly Used Defense Sites (FUDS)—properties transferred from Department of Defense (DoD) control prior to 17 October 1986—and Army, Navy, and Air Force ranges on installations closed under the Base Realignment and Closure (BRAC) legislation in 1988, 1991, 1993, and 1995. The MRSs and MRAs that have mature munitions cleanup programs have the greatest value. Data from ranges where cleanup action is complete and the land has been transferred and put into use were made a priority for analysis. All ranges considered as sources of data were at a minimum in the Engineering Evaluation/Cost Analysis (EE/CA) phase. Primary sources of information included the U.S. Army Engineering and Support Center in Huntsville, Alabama; the U.S. Army Corps of Engineers (USACE)—Baltimore District; the Naval Facilities Engineering Command; and open source literature and documents.

1.3.2 Review Information

As the information collected was reviewed, the data were placed into one of three major groups according to the general range use patterns and size:

- Direct-fire weapon system, such as rifle grenades, rockets, and recoilless rifles
- Indirect-fire weapon system, such as mortars and heavy artillery
- Air-delivered weapons or bombs

From these three groupings, ranges were selected for detailed review and presentation. The examples selected were chosen to represent some of the better documented larger and more complex UXO cleanup programs. Because ranges may be used by a multitude of weapon systems, these general groupings should not be viewed as exclusively direct, indirect, or air-delivered ranges.

1.3.3 Develop and Present the Information

Generic profiles were developed for each of the three site categories. The profiles include the physical environment or setting, land-use subsequent to range closure, and the type of range based on the MEC found at the range. Examples from each category have been identified and

site specific characterization information has been summarized and tabulated for presentation in the report.

1.4 Report Layout

Section 2 describes site information for an MRA or MRS in generic terms applicable to all sites; this information includes an explanation of how and why surface danger zones (SDZs)—also known as range fans—were designed and provides an explanation of firing points and firing lines. Section 3 defines and describes direct-fire weapon ranges. Section 4 describes indirect-fire weapon ranges. Section 5 describes air-delivered weapons (bombing and gunnery) ranges. Section 6 contains references to the documents and other data sources analyzed to create this document. Also included is a list of references that every UXO program manager should have as part of their reference library. Section 7 contains a list of acronyms and a glossary for commonly used terms.

Appendixes A, B, and C provide case studies on the three types of ranges. The example ranges reviewed for this report come from numerous documents. These ranges have been cleared of UXO in many ways over a long period of time. The data reported for these ranges varies widely in terms of the type and quality of the data collected, which makes it difficult to present a uniform and consistent format for each range example. Nevertheless, an effort was made to “normalize” the data presentation as much as possible. While the report categorizes the ranges into three groups—direct fire, indirect fire, and bombing and gunnery ranges, the same range may be presented as an example in more than one group because the weapons used at the range fall into more than one group and the quality of the information available was considered superior to other examples examined. Finally, the examples presented in Appendixes A through C were designed as stand-alone inserts to provide flexibility. This scheme makes it easy to update the report by simply adding or subtracting examples.

Appendix D provides a selected set of standard range fan designs compiled originally to aid data collectors for the Army Range Inventory Database (USACE-St. Louis, 2002).

Appendix E provides selected example images from ORDATA II (NAVEODTECHDIV, 1999) of military ordnance types that have been found on various ranges. The ordnance images are grouped by the most common range type where they might have been used.

SECTION 2 - SITE INFORMATION

2.1 Physical Characteristics

The physical characteristics of an MRA or MRS play an important role in efforts to identify, locate, and possibly retrieve MEC. Major physical characteristics affecting MEC assessment include:

- Topography and vegetation
- Geology and hydrology
- Erosion
- Frost
- Background clutter information

Topography and vegetation may influence the areal or horizontal MEC distribution pattern, while geologic conditions affect the initial depth. Soil type influences the penetration depth and may impact some geophysical instruments when trying to identify MEC.

Subsequent to MEC emplacement, physical processes or human activities may alter the location and depth of a MEC hazard. Natural processes such as erosion, scouring, flooding of soil or sediment, frost heave, or tidal currents can also redistribute MEC and may either expose the MEC or bury it deeper. Prior UXO clearance activities or investigations may have resulted in some MEC removal, but human activities after UXO clearance—such as excavation, plowing or tilling, and surface soil or vegetation removal—may have caused any remaining MEC to be moved from its original depth or location. Thus, when developing a site profile, it is important to consider both human activities and the physical processes associated with the MEC source area.

Range maintenance actions while the range was operational were likely used to limit the effects of erosion so that training would not be compromised. After range operations ceased, it is unlikely that erosion control measures were continued. Thus, erosion may be an important physical process, especially when vegetation is inadequate to stabilize the soils, the source area has significant topographic relief, and intense precipitation events or rapid snowmelt runoff are common. If erosion is occurring, MEC may have been exposed or moved by flowing water depending on the MEC's weight and the water volume and speed. It is important to consider that both erosion and erosion control may have changed the physical condition of the soil. For example, areas with MEC could now be buried under soil or sediments deposited by moving water and MEC may be present below the expected penetration depths. Furthermore, under certain climatic conditions and soil textures, frost heave may become significant and result in bringing MEC up to the land surface or to a depth already cleared. Frost heave is most likely where the freeze thaw cycle is common and the soil texture is silty. Frost heave is relatively unimportant in coarse-grained sands and cobble-rich soils.

Natural or manmade features can affect the search for MEC, its detection, and recovery. These features include high topographic relief, rough or unstable terrain, wetlands, surface water bodies, and impenetrable vegetation. For example, terrain and vegetation often affect the

selection of geophysical equipment and methods, and these features may hinder application if the field conditions make it difficult to drive or walk across the terrain. In addition, soil type and composition may limit the effectiveness of some geophysical instruments; it is important to understand the environmental conditions and the potential limitations of the geophysical equipment during the survey design. Also, when reviewing geophysical information, it is important to know the equipment type(s) used and the inherent limitations of that equipment and any additional limitations imposed by the field conditions.

Most geophysical technologies in use or proposed to characterize an MRS or an MRA suffer from false alarms, even at modest probabilities of detection. False alarms are a consequence of the inability to discriminate real UXO from manmade clutter and naturally occurring (background) noise and the desire to ensure that UXO are not missed by the survey. Manmade clutter includes MEC-related matter, such as fragmentation or banding from ordnance packaging and non-MEC-related matter, such as fencing materials, pipelines, nails, and other metal debris. In addition, some geologic conditions—such as high metallic mineral content or abrupt changes in soil texture and moisture—can affect some geophysical instrument readings and, for ground penetrating radar, the depth of penetration. Fluctuating or difficult environmental conditions may lead to increased background noise.

Land use since ordnance activities ceased may be quite different. It is important to understand how the historic land-use or any land-use restrictions could have influenced MEC location or distribution. Activities that may have occurred since range closure could include the following:

- Construction
 - Residential
 - Industrial
 - Commercial
- Agricultural activities
 - Livestock grazing
 - Crops
 - Logging
- Recreational
 - Hiking
 - Off-road vehicle access

Any post-range use may also have changed the original look of the range. This change in use could vary from animal grazing—which would be expected to have a minimal impact on the overall site or portions of it—to activities such as road construction or earth moving, which would have a significant effect. Properties in the FUDS program have been out of government control since 1986 and often were transferred to entities that put them into reuse and upgraded the infrastructure with roads and buildings.

Another land-use possibility is tree-farming and logging. The timber industry is quite robust in the southeastern portion of the United States, where southern yellow pine grows rapidly and

can be harvested every 10 to 15 years. Such activities can drastically change the appearance of the landscape and make it difficult to traverse with survey equipment.

There is also a possibility for MEC redistribution, which can occur with agricultural plowing or earth-moving activities. These activities can either expose or bury MEC deeper; in some cases, it can result in transport of MEC to other areas if the excavated soils contain MEC and are used as fill at other locations.

2.2 Factors Controlling MEC Distribution and Depth

There are many factors that influence our understanding of the MEC distribution on a particular range. The primary factor is the availability of MEC use records and ordnance activity records detailing the probable weapon systems used and the locations and dimensions of the expected MRS. The following items can also be helpful in understanding the MEC distribution:

- Type of use
 - Single-use or multiple-use
 - Duration
 - Firing points
 - Impact areas
 - Expected type and distribution of MEC
- Geophysical data
 - Scope and type of geophysical surveys
 - Anomaly density and type
- Ordnance impact dispersion patterns and shapes
- Range management history
- MEC hazards

Some of the information used in developing the MEC distribution profile was gathered from sites that were in the early phases of the cleanup process or sites that were addressed using an EE/CA. In addition, other documents, such as a Site Investigation (SI) or a Remedial Investigation (RI), may provide similar information. Users of this report should also consider reviewing maps and aerial photographs, as well as conducting or reviewing the notes from interviews with individuals who formerly worked at the installation and were familiar with the activities conducted at the ranges. In general, BRAC sites have more information available than FUDS because BRAC sites have remained under government control longer and generally have more mature programs.

The SDZs or range fans depict the dimensions of the theoretical range design, which is often a fan-shaped area encompassing the target location and the area beyond where misdirected shots that do not hit the target—either in azimuth or elevation—will impact. Each weapon has its own geometric definition of an SDZ that is further modified by specific munitions and by firing and target conditions. The SDZs provided in this report represent a general range layout. Some of the range fans were developed using historical documents, and some are based on current documents to demonstrate the variability in range configurations to accommodate the changes in weapon systems over the last several decades. It is important to note that development of SDZs for Army

weapon systems have recently undergone a major policy revision with the May 2003 release of Army Regulation 385-63, Range Safety. Although range-safety practices have been employed since the beginning of military history, this new regulation/order by the Department of the Army significantly enhanced range safety and updated environmental considerations. Although this latest regulation post-dates the use and closure of the ranges presented in this report, it may still be useful because the underlying factors affecting range design remain.

In theory, a range would be designed to contain a number of components:

- A firing point where all ordnance is fired downrange from a single point
- A firing line where ordnance firing may occur anywhere along a specified line a 30 to 90 meters in length
- Minimum range to impact
- A downrange buffer
- A safety fan with a specified angle for assumed right and left firing limits
- An angle of fire
- Ricochet zones, where applicable

A generic SDZ is shown in Figure 2-1. A complete set of historic and current SDZs is located in Appendix D. Figure 2-2, a common scenario, shows how an historical complex of ranges might appear and how SDZs could overlap, resulting in a common impact area over time by multiple weapon systems. In general, a discrete training site used by a single weapon system is rare. In most cases, a single weapon system cannot be isolated, which adds to the complexity of characterizing an MRA.

Note: Empirical data and historical records indicate that ad hoc use of ranges for ordnance types that are different from the original intended range use was a common occurrence.

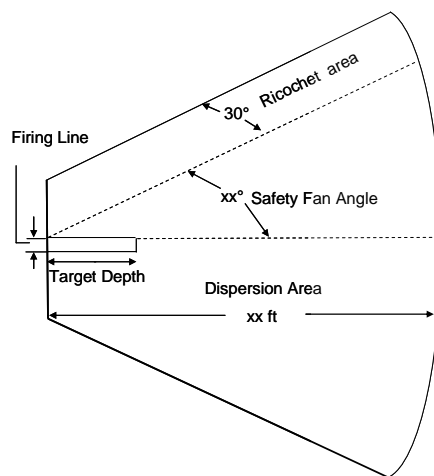

Figure 2-1. Conceptual Surface Danger Zone (SDZ) for Direct Fire Weapons System



Figure 2-2. Theoretical Range Complex with Multiple Weapon Systems

Ordnance areal dispersion and vertical penetration depth show some recognizable trends depending on the use profile, including the type of weapons system(s) used, the duration of use, the firing positions, the range maintenance history, the physical features addressed below, and prior UXO investigations and removal actions. Theoretically, the ordnance distribution should be most dense around the target area and decrease in density with distance from the target area.

The depth that ordnance will penetrate depends on the ordnance shape, weight, angle of impact, velocity, materials of construction, and soil type. In general, soil density and grain size are both inversely proportional to the penetration depth, while water content and the angle of penetration are both directly proportional to the penetration depth. Thus, penetration depth is greatest when the soils are fine-grained and saturated and the angle of penetration is near vertical. Penetration depths are lowest when the soils are dry and coarse-grained and the entry angle is low. Experience has shown that after impact, ordnance will typically follow a J-shaped trajectory (Figures 2-3 and 2-4).

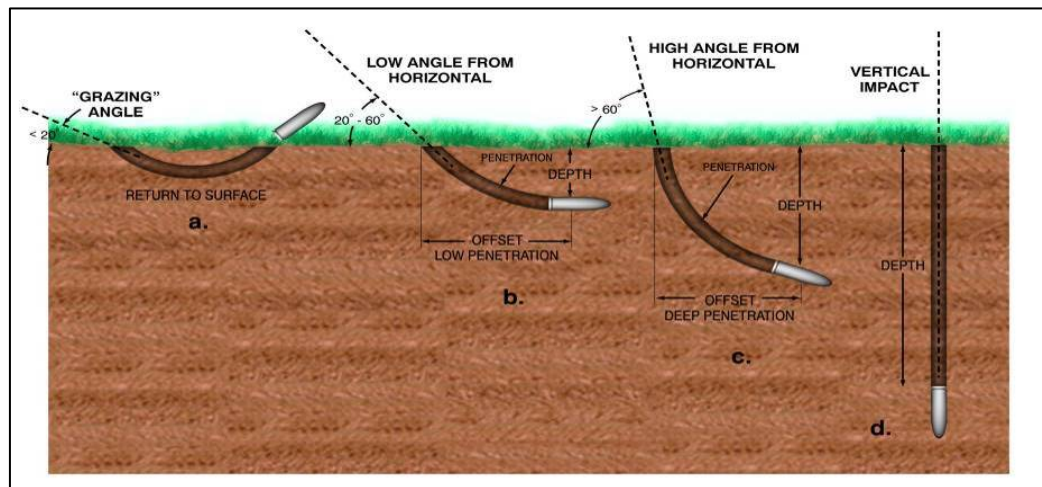

Source: Modified from Butler, et al., ERDE/GSL TR-04-8, 2004.

Figure 2-3. Penetration Angle and Correlation to Depth of Penetration

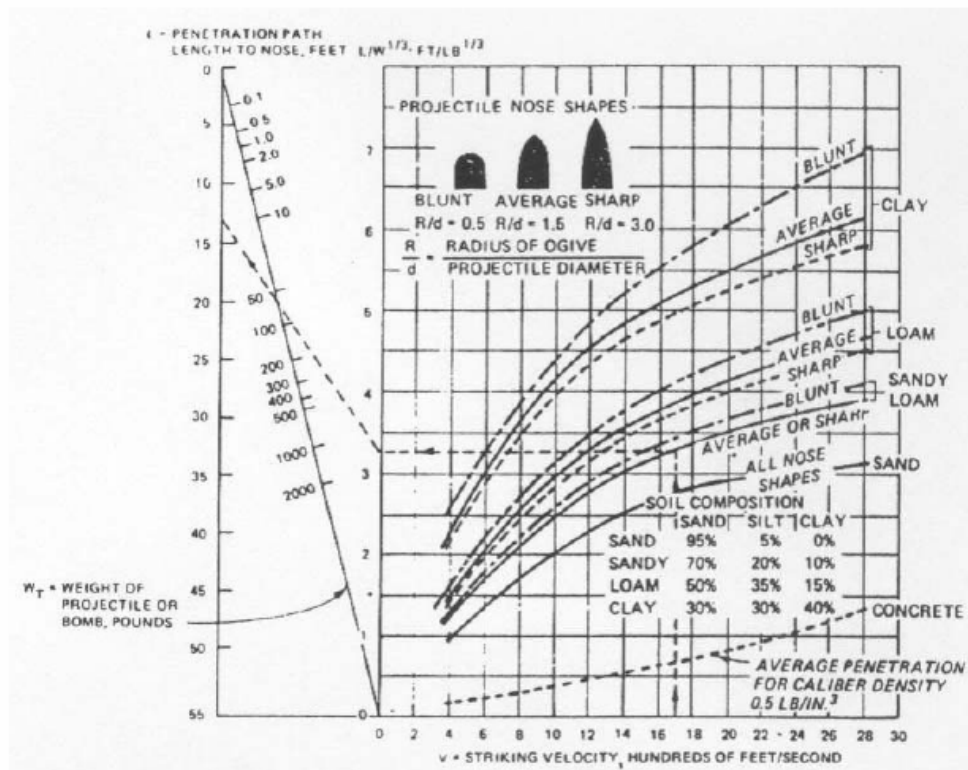

The graph and nomogram give the relation between velocity and penetration path length, measured to the nose, for projectiles or bombs of various weights penetrating into several soils. Curves marked blunt, average, and sharp are for projectiles of different nose shapes, as sketched. Where no appreciable effect of nose shape on penetration has been observed, only a single curve is drawn. The dependence of penetration path length on projectile weight, as given by the nomogram, agrees with observations for projectiles or bombs having caliber densities from 0.15 to 0.65-lb/in.³. Most bombs and artillery projectiles have caliber density values (weight of projectile in pounds divided by the cube of the diameter in inches) within the above range.

Trajectories in soils are usually straight for two-thirds or more of the path length, but curve near the end of the path (see sketch). For this reason, final distance from the surface is usually 10% to 30% less than the penetration path given here.

Curves given are for average soil types. Penetrations into rich plastic clay are approximately 30% greater than those observed in clay. The dotted curve at the bottom of the graph gives average penetration into good quality reinforced concrete, and is added here for rough comparison.

EXAMPLE The dotted line shows that a projectile of average nose shape and weight of 60-lb striking sandy loam soil with a velocity of 1700-ft/sec will have a path length of approximately 12.5-ft, measured to the nose. Because of the curvature of the underground trajectory, the actual penetration from the surface will be somewhat less.

SOURCE British and American tests with bombs and large caliber projectiles at velocities below 1100-ft/sec. Small caliber tests for the Corps of Engineers, USA extending over entire velocity range. The curves agree with measurements to $\pm 20\%$.
NDRC Weapon Data.

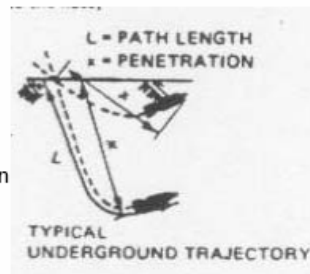

Source: Army Manual TM-5-855-1

Figure 2-4. Projectile Penetration Depths

In general, the larger the target item, the deeper it can be detected relative to a smaller target of the same type and orientation using the same detection sensor. Based on work at Jefferson Proving Ground and other sites, the U.S. Army Corps of Engineers developed two empirical formulas that reflect how deeply a munitions item can be expected to be detected with existing magnetic and EMI technology (EM 1110-1-4009, USACE, 2000). More recently, the industry has adopted a single, simpler formula that is becoming known as the “Corps of Engineers rule-of-thumb” or the “11x depth” (DID MR 005-05.01, USACE, 2003):

$$d = 11 \times dia$$

where:

d = depth of detection of top of buried munition (constant units)

dia = diameter of minor axis of munition (constant units)

This relationship reflects a correlation observed across several sites and is not based on any underlying physical model. A plot of “11x” formula is shown in Figure 2-5.

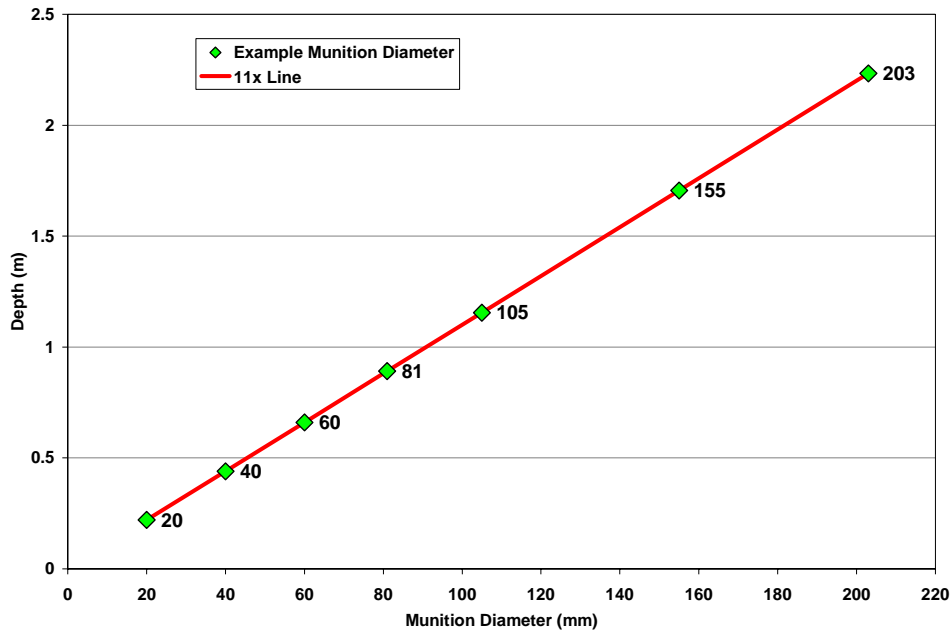

Figure 2-5. “11x” Formula Plot

Empirical data for MEC detection depths based on system demonstrations at the U.S. Army Environmental Center (USAEC) Standardized UXO Technology Demonstration Site at Aberdeen Proving Ground (APG) is shown in Figure 2-6. These charts show two depth-related performance measures: the depth to which *all* seeded munition items were found (100% Detection Depth) and the maximum depth at which *any* munition item was found (Max Detection Depth). The “11x” depth line is also shown in each chart. More detailed information and analysis of these tests can be found at the USAEC Standardized UXO Technology Demonstration Site Program [website](#) and in the “Survey of Munitions Response Technologies” report produced jointly by SERDP/ESTCP and the Interstate Technology Regulatory Council (ITRC) (2006).

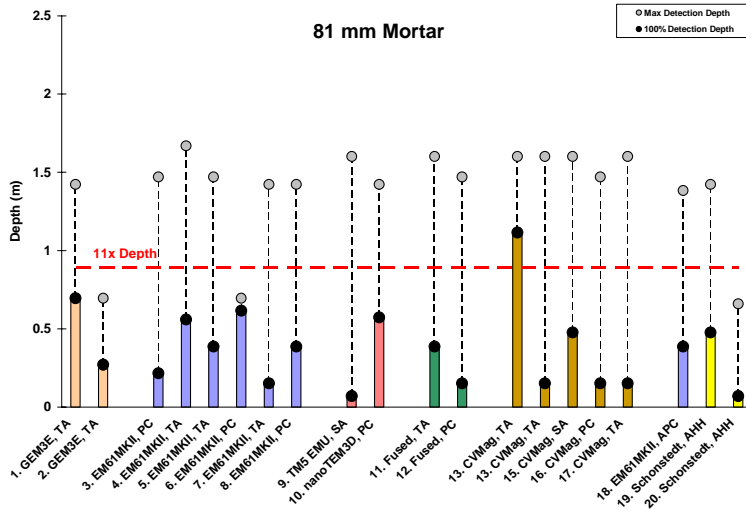
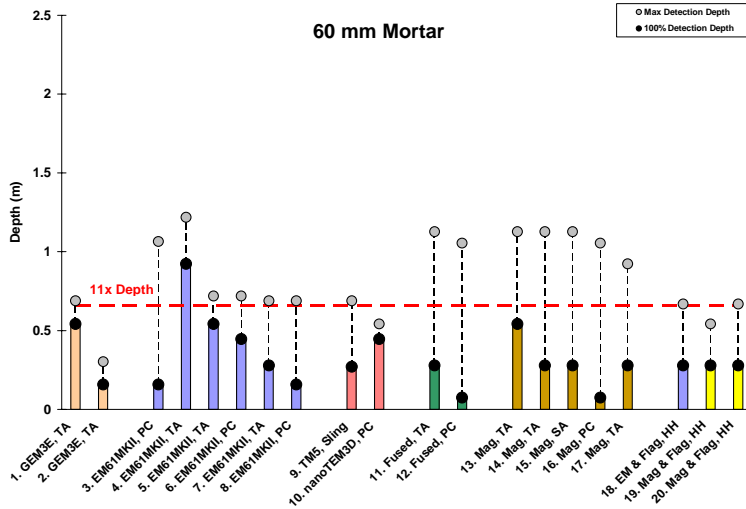
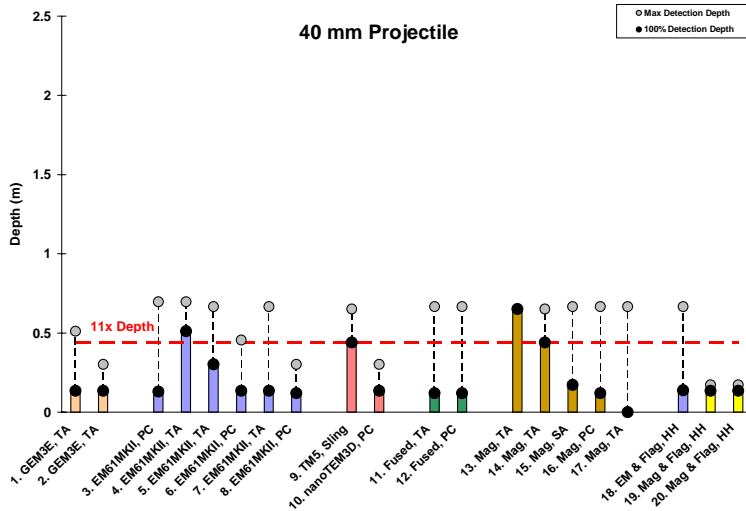
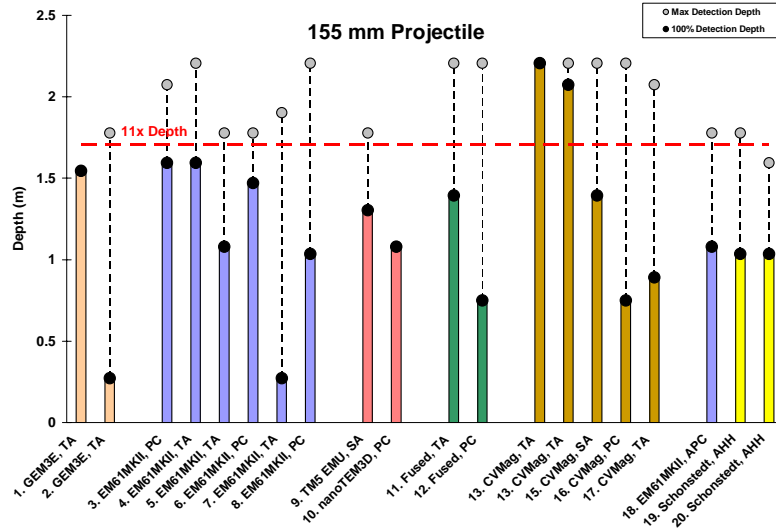
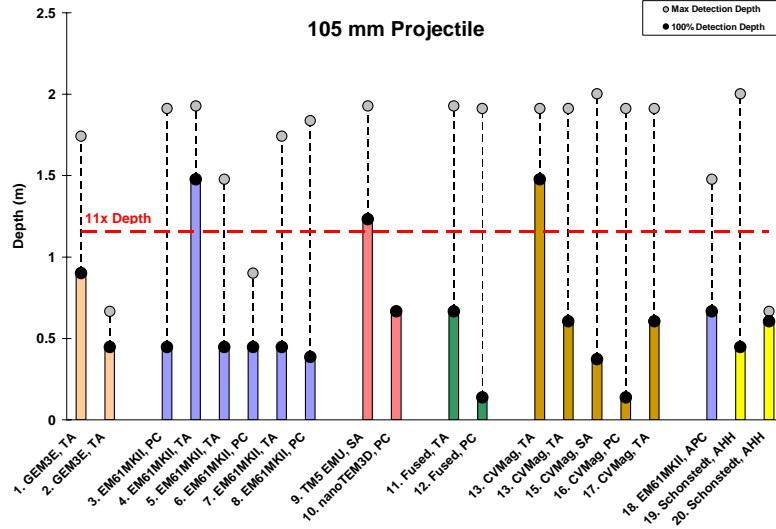

Figure 2-6. Performance of Selected Detection Systems at the APG Open-Field Standard Test Site (100% Detection Depth and Max Detection Depth)



KEY

Label	Operator	System	Platform
1. GEM3E, TA	Naval Research Laboratory	MTADS 3x GEM3	Towed Array
2. GEM3E, TA	GeoPhex	GEM3E	Towed Array
3. EM61MKII, PC	Tetra Tech/Foster Wheeler	EM61MKII	PushCart
4. EM61MKII, TA	Naval Research Laboratory	3x EM61 Variant	Towed Array
5. EM61MKII, TA	NAEVA	EM61MKII	Towed Array
6. EM61MKII, PC	Shaw	EM61MKII	Push Cart
7. EM61MKII, TA	GeoCenters	EM61MKII	Towed Array
8. EM61MKII, PC	Blackhawk Geoservices	EM61MKII	Pull Cart
9. TM5 EMU, SA	G-Tek Australia PTY, Limited	TM5 EMU	Sling
10. nanoTEM3D, PC	Zonge	nanoTEM3D	Push Cart
11. Fused, TA	GeoCenters (2002)	STOLS, Simultaneous Magnetometry and Pulsed EM	Towed Array
12. Fused, PC	Black Hawk	Simultaneous Magnetometry and Pulsed EM	Pull Cart
13. CVMag, TA	Naval Research Laboratory	MTADS 8x G822 Variant (low threshold)	Towed Array
13. CVMag, TA	Naval Research Laboratory	MTADS 8x G822 Variant (high threshold)	Towed Array
15. CVMag, SA	G-Tek Australia PTY, Limited	TM4 2x G822A	Sling Array
16. CVMag, PC	BlackHawk	4x G822	Pull Cart
17. CVMag, TA	GeoCenters (2004)	5x G822A	Towed Array
18. EM61MKII, APC	Parsons	EM61MKII	Analog Push Cart
19. Schonstedt, AHH	Human Factors Applications	Schonstedt	Analog Hand Held
20. Schonstedt, AHH	Parsons	Schonstedt	Analog Hand Held

(Modified from SERDP/ESTCP and ITRC, 2006.)

Figure 2-6. Performance of Selected Detection Systems at APG Open-Field Standard Test Site (100% Detection Depth and Max Detection Depth) (Concluded)

SECTION 3 - DIRECT-FIRE RANGES

3.1 General Description

A direct-fire weapon system is one where the target is seen and the weapon is aimed directly at the target. These weapon systems require a line-of-sight from the firing point to the target to ensure that the operator can engage the target and employ the weapon system realistically during training. Thus, ranges suitable for these weapon systems are typically flat or gently rolling. In their original state, most direct fire ranges were relatively free of trees.

Direct-fire ranges can vary widely because ranges are often designed to mimic expected combat conditions. Nevertheless, many direct fire ranges are relatively flat, wide areas; this type of land is often the most desirable for reuse because a minimal amount of earth movement is needed to establish building sites. For similar reasons, these sites may also be desirable for agricultural use such as crop production, grazing, or tree farming.

Direct-fire ranges were typically designed for a wide variety of weapon systems. Common direct-fire weapon systems include rifle grenades, recoilless rifles, and anti-tank rockets. The life of the range most likely spanned the introduction of several direct-fire weapon systems with different munitions used at different distances from one or more firing points. For example, a range originally designed for use with the 2.36-inch rocket (World War II to early Korean War) is likely to have been modified to permit use of the 3.5-inch rocket (Korean War to Vietnam War) and later the introduction of the 66mm M72 Light Anti-tank Weapon (Vietnam War). These ranges may also have been used for recoilless rifle training, which would require extended impact areas, buffer zones, and SDZs larger than those previously in use.

The ranges require a firing point or firing line and targets with known distances for each weapon type. The ranges may overlap or include firing lines for several different types of weapon systems to minimize the amount of land required and maximize its usage. The distances between firing points and targets are determined by the weapon system's engagement parameters (useful range, terrain, lethality, and use), point targets such as vehicles and bunkers, or area targets such as personnel and terrain.

The targets typically employed on direct-fire ranges include a variety of items from wood and cloth targets to car bodies, excess armored vehicles (see Figure 3-1), and concrete bunkers. Targets may be stationary or mobile, depending on the specific weapons system employed or the availability of target material.

A range's dimensions will also vary depending on the number of firing points, targets, and target distances, as well as the proximity to other ranges and weapon systems. There is a vast difference between the size of the range required for firing a weapon, such as a 2.36-inch anti-tank rocket (bazooka) with a typical target range of 100 to 300 meters (maximum range 650 meters) versus a 37mm armor-piercing (AP) projectile, which has a target range well over 1,520 meters (5,000 feet) and a maximum range of about 4,000 meters (12,900 feet). The standard footprint for a 2.36-inch rocket range is about 200 acres, while the standard footprint for the 37mm projectile is considerably larger—about 11,500 acres, or nearly 18 square miles (USACE–St. Louis, 2002).



Figure 3-1. Armored Personnel Carrier in Place for Use as Target

For some weapon systems, it is also possible to adjust the charge and, hence, the maximum range. This is sometimes done to allow training on ranges where the available acreage is less than ideal and the weapon's maximum range needs to be reduced for use on that particular training range. Thus, it is important to remember that a range can appear too small for training using a particular type of weapon but that weapon still may have been used after adjusting the weapon's charge.

A typical range layout for rifle grenades and 2.36-inch rockets is shown in Figure 3-2; this figure can be used to help demonstrate how a range is typically designed. The range dimensions were primarily based on four factors: the maximum range of the weapons—in this case the anti-tank rocket and rifle grenades, the width of the firing line, the type of targets (stationary or moving), and the target locations. In this example, stationary targets were assumed to be at 90 meters, 180 meters, and 270 meters (300 feet, 600 feet, and 900 feet) from a firing line 90 meters (300 feet) wide.

The maximum range for these two weapon systems is about 630 meters (2,100 feet) for the anti-tank rocket and less than 360 meters (1,200 feet) for the rifle grenades. Based on the weapon with the greatest range, the length of the firing range was established at the maximum range of the weapon (minimum SDZ), plus an additional 270 meters (900 feet) in this example, for a total range distance of 900 meters (3,000 feet). The angle of fire was set by adding 10° to each side of the target area, which was assumed to be 20° wide or 356 mils. An additional 180 meters (600 feet) was also added to the danger zone on either side of the angle of fire. This results in a range that is approximately 180 acres including the impact area and danger zone. Unexploded rockets or rifle grenades may be expected to be found throughout this area. The largest concentration should be in the vicinity of the targets. However, the final target areas at the time of closure may not be the same target locations used throughout the history of the range (USACE–St. Louis, 2002).

Another example of a direct fire range is the recoilless rifle range shown in Figure 3-3. This range requires about 8,700 acres and would be considered a large range.

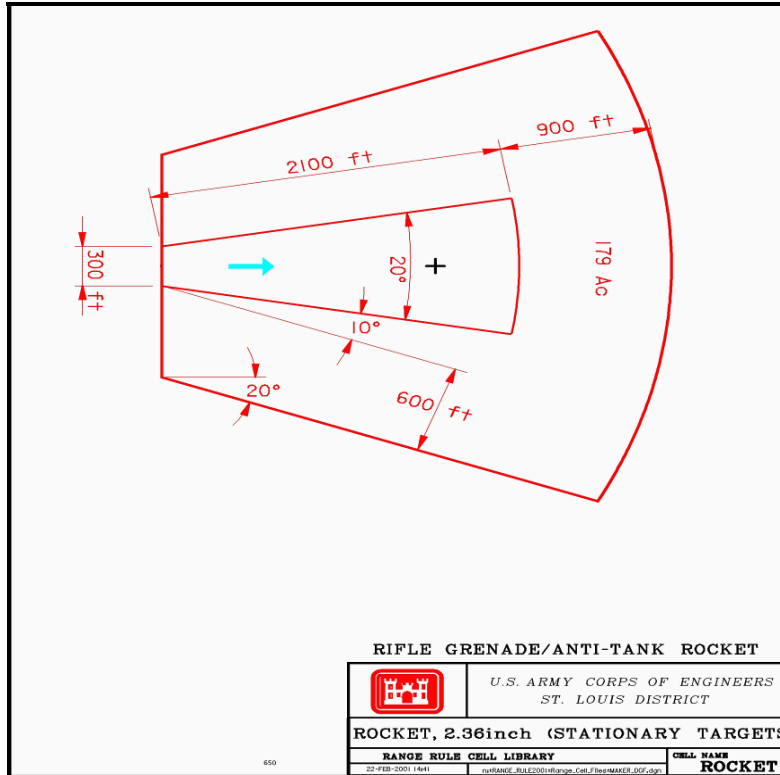

Source: USACE–St. Louis, 2002

Figure 3-2. Standard Rifle Grenade/Anti-Tank Rocket SDZ

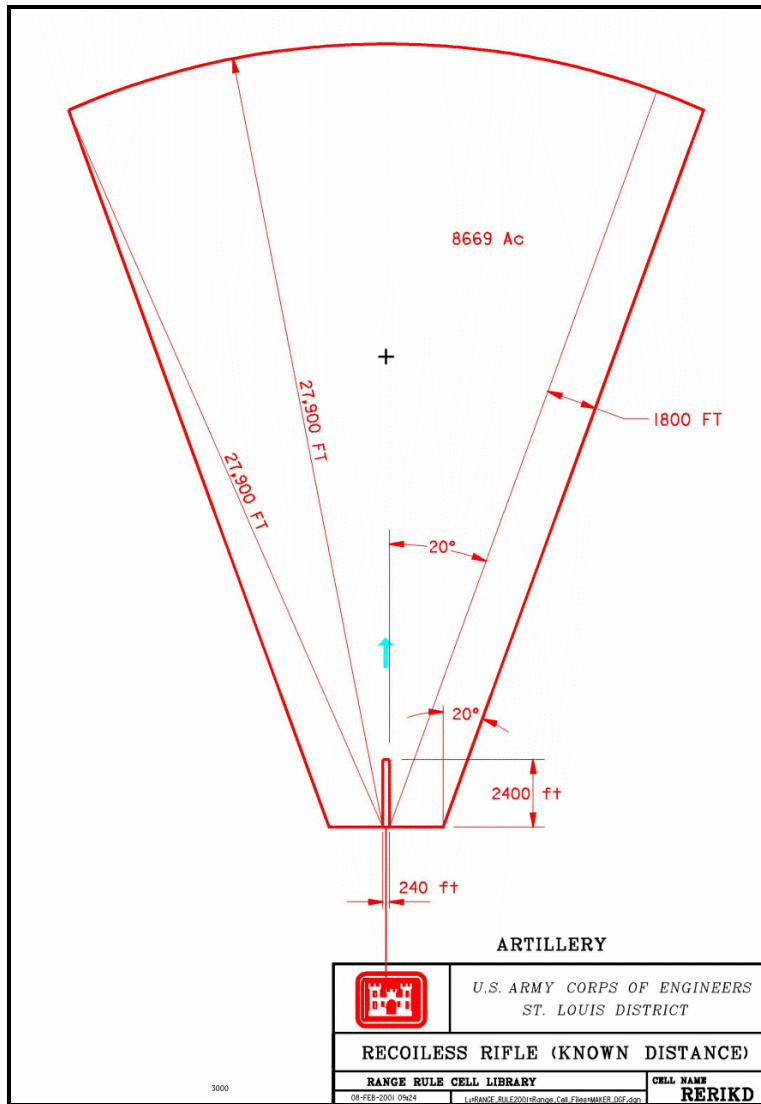

Source: USACE–St. Louis, 2002

Figure 3-3. Standard Recoilless Rifle Range

The recoilless rifle range is about 730 meters (2,400 feet) long with individual firing lanes spread across its width. Each firing point has a 9-meter (30-foot) back blast area extending to each side. This requires that the weapon firing lanes be approximately 18 meters (60 feet) wide. In this example, it has been assumed that there will be 4 lanes for 57mm munitions resulting in a total firing line length of about 73 meters (240 feet). Targets are typically 55-gal drums or 1-meter by 2-meter log barriers, positioned at 270, 450, and 730 meters (900, 1,500, and 2,400 feet) from the firing line for 57mm munitions; and 360 and 730 meters (1,200 and 2,400 feet) for 75mm munitions. Note that the impact area extends more than 6,000 meters (20,000 feet) beyond the maximum target distance of 730 meters (2,400 feet) based on the long range of these weapon systems. For this example, the impact area extends out to the maximum range of the weapon, which assumes a firing position at an angle of 15° from the horizontal, plus a danger area of about 1,830 meters (6,000 feet). The right and left limits of fire are estimated at 20° but could be

different depending on local conditions. Danger areas of 550 meters (1,800 feet) have also been added to both sides of the range.

Table 3-1 provides a list of direct-fire ordnance types used during the World War II era, the maximum range in meters and feet for each type of ordnance, and the standard range acreage that is generally required for each ordnance type. Example images and diagrams for many of these ordnance types can be found in Appendix E. As can be seen, ranges can be as small as a few hundred acres (rifle grenade practice) to more than 15 square miles (37mm artillery practice).

Figure 3-4 shows the standard range layouts associated with each of these range types. Detailed descriptions of these range designs can be found in Appendix D. Examples of actual direct fire ranges are presented in Table 3-2 with known or estimated range sizes and ordnance types found or suspected to be present.

Table 3-1. Direct Fire Ranges and Probable Ordnance Types (WWII Era)

Range Name	Ordnance Type	Max Range (meters/feet)	Standard Acreage
Artillery	37mm gun – HE, MkII	3,900/12,900	11,506
	37mm gun - Practice, MkII	3,900/12,900	
Grenade, 40mm (Live; Practice)	40mm, HE	366/1200	3
	40mm, Parachute, Star		
	40mm, Practice		
Rifle Grenade Practice	Rifle Grenade, Practice	360/1,200	3
Ground Towed Target	37mm AP	4,530/14,850	6,225
	2.36-Inch Rocket, Practice	640/2,100	
	Rifle Grenade, Practice	<360/<1,200	
Recoilless Rifle (Known Distance)	75mm Recoilless Rifle	6,400/21,000	8,669
	57mm Recoilless Rifle	3,900/12,900	
	.50 Caliber	6,860/22,500	
	.30 Caliber	3160/10,350	
Rocket 2.36-inch (Moving Targets)	Rocket, 2.36-Inch Anti-Tank	640/2,100	209
	Rocket, 2.36-Inch, Practice	640/2,100	
	Rifle Grenade, Anti-Tank, Practice	360/1,200	
Rocket 2.36-inch (Stationary Targets)	Rocket, 2.36-Inch Anti-Tank	640/2,100	179
	Rocket, 2.36-Inch, Practice	640/2,100	
	Rifle Grenade, Anti-Tank	360/1,200	
	Rifle Grenade, Practice	120/400	
Rocket, 3.5-Inch (Moving Targets)	Rocket 3.5-Inch Practice	390/1,300	496.5
	Rocket, 3.5-Inch, Anti-Tank, WP	288/945	
Rocket, 3.5-Inch (Stationary Targets)	Rocket 3.5-Inch Practice	390/1,300	496.5
	Rocket, 3.5-Inch, Anti-Tank	288/945	
	Rocket, 3.5-Inch, WP	288/945	
	Rifle Grenade, Practice, Heat	120/400	
Tank (Main Gun)	75mm gun – Shrapnel1, Mk1	8915/29,250	22,917
	75mm gun – HE M48	12,431/40,785	
	75mm gun - Shot, AP, M61	12,482/40,950	

Source: USACE–St. Louis, 2002

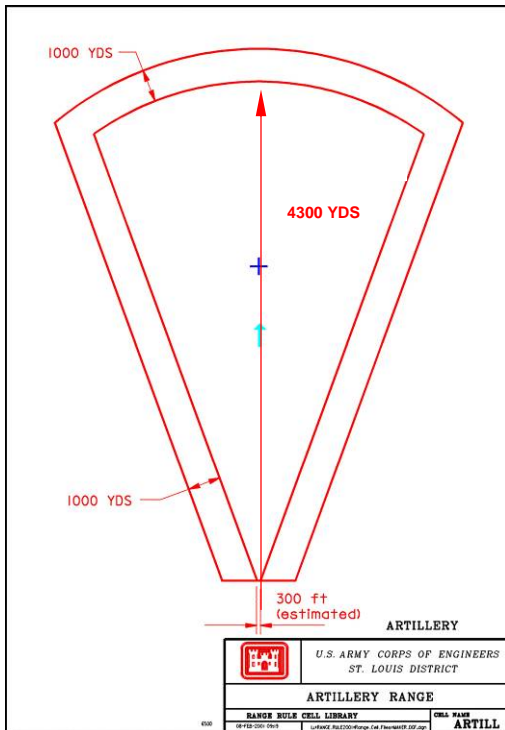

Artillery, 37mm

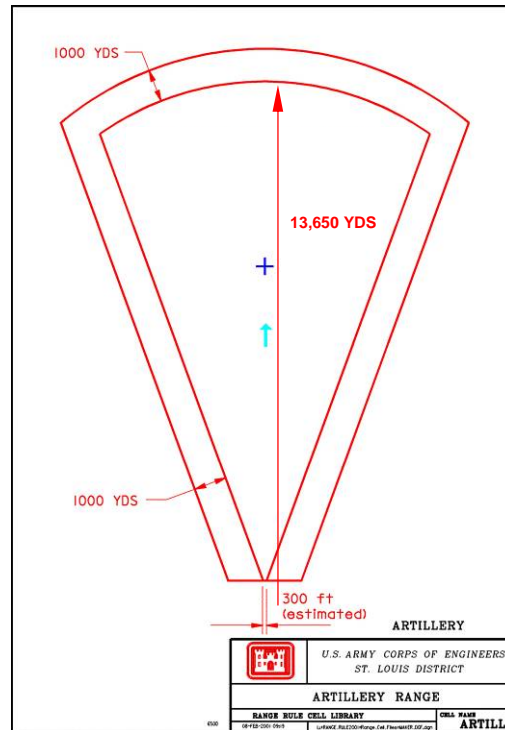

Tank (Main Gun)

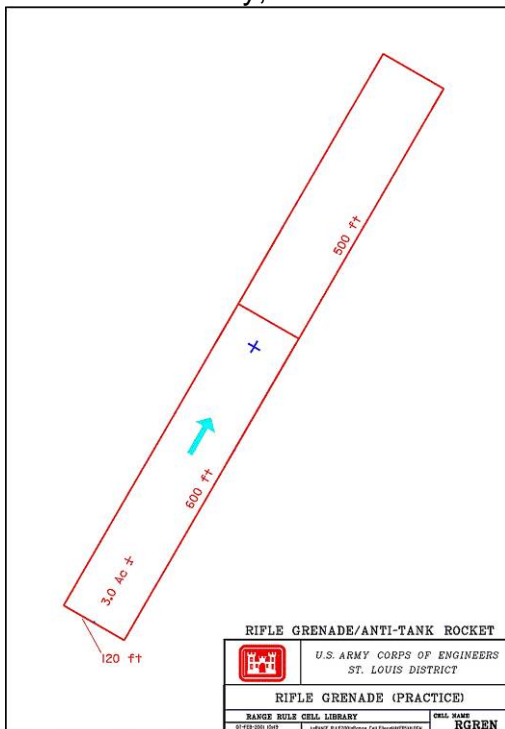

Rifle Grenade (Practice)

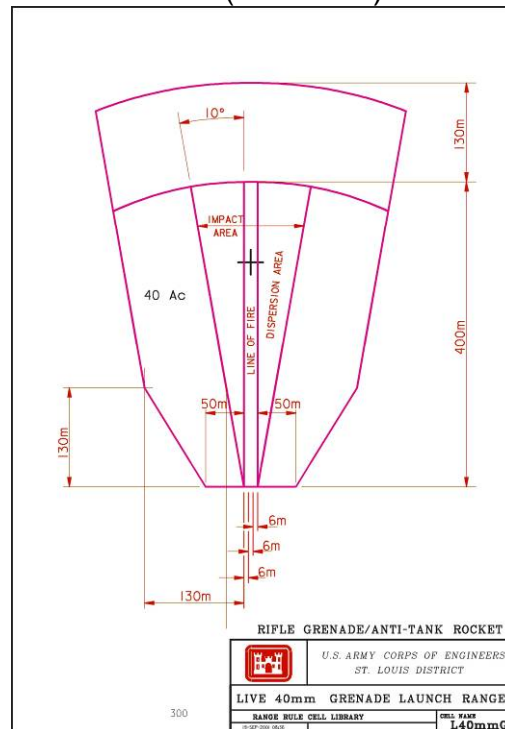

Grenade Launch, 40mm (Live)

(Source: USACE–St. Louis, 2002)

Figure 3-4. Standard Direct Fire Range Diagrams

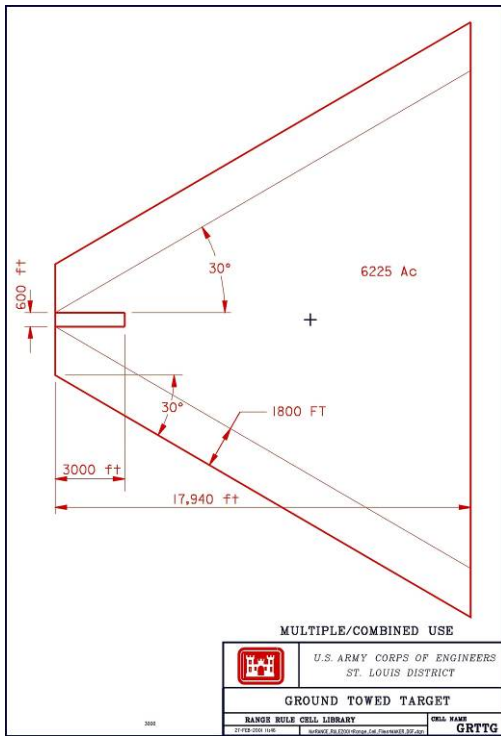

Ground Towed Target

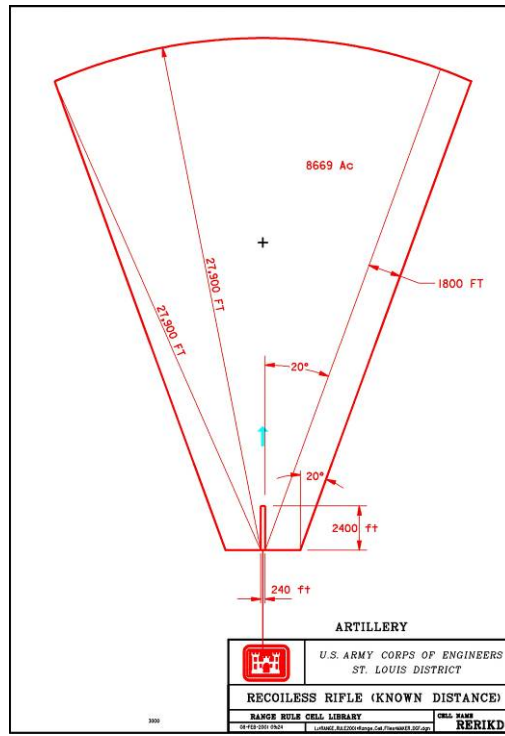

Recoilless Rifle (Known Distance)

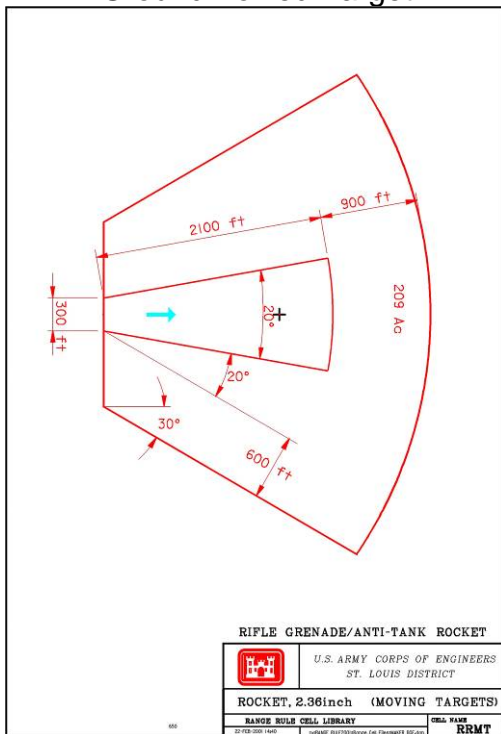

Rocket, 2.36" (Moving Targets)

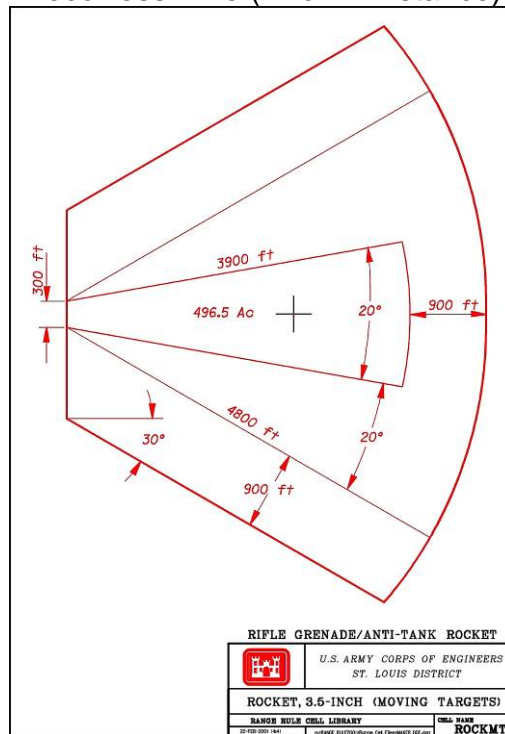

Rocket, 3.5" (Moving Targets)

(Source: USACE–St. Louis, 2002)

Figure 3-4. Standard Direct Fire Range Diagrams (Concluded)

Table 3-2. Range Examples – Direct Fire

Description	Range Diagram or Photo
<p>Site: Fort Ritchie (MD)</p> <p>Range Name: 200-yd Range</p> <p>Range Type(s): Rocket, 2.36-Inch; Rifle Grenade</p> <p>Target Distance: 183 m; 91 m; 46 m</p> <p>Range Length: 914 m (estimated)</p> <p>Range Area: 70 acres (estimated)</p> <p>Safety Zone: 250 acres (estimated)</p> <p>Ordnance Types: Rocket, 2.36"; Rifle Grenade</p>	
<p>Notes: Estimated SDZ's overlaid based on documented firing points, target distance, and munitions used.</p>	
<p>Site: Fort Ritchie (MD)</p> <p>Range Name: Quirauk Mountain Hillside</p> <p>Range Type(s): Artillery (37 mm); Mortar</p> <p>Target Distance: 850 m (estimated based on found MEC pattern)</p> <p>Range Length: 1495 m (estimated based on distance to Quirauk Mountain ridgeline)</p> <p>Range Area: 135 acres (estimated)</p> <p>Safety Zone: 772 acres (estimated)</p> <p>Ordnance Types: Projectile, 37 mm; Mortar, 60 mm, 81 mm, 3" Stokes, 50 mm Japanese "Knee"</p>	
<p>Notes: Estimated SDZ's overlaid based on documented firing points, target distance, and munitions used.</p>	

Table 3-2. Range Examples – Direct Fire (Concluded)

Description	Range Diagram or Photo
<p>Site: Fort Ord, CA</p> <p>Range Name: Del Rey Oaks Area, Range #26</p> <p>Range Type(s): Machine Gun; Rocket, 2.36-Inch Rocket, 3.5-Inch; Mortar</p> <p>Target Distance: Unknown</p> <p>Range Length: 871 m</p> <p>Range Area: 79 acres</p> <p>Safety Zone: Unknown</p> <p>Ordnance Types: Signal, Illumination; Rocket, 2.36" and 3.5"; Rifle Grenade, Smoke, Practice, and Frag; Projectile, 37 mm; Small Arms</p> <p>Notes: Range 26 is referred to as the machine gun transition range in historical records. It was also used for 2.36-inch rocket training, 3.5-in. rocket training, 37mm gun training, and mortar training. (Note that no removal action was conducted in the Multi-Range Impact Area.)</p>	
<p>Site: Fort Ord, CA</p> <p>Range Name: Del Rey Oaks Area, Range #24</p> <p>Range Type(s): Rocket, 35 mm, Subcal Projectile, 40 mm</p> <p>Target Distance: Unknown</p> <p>Range Length: 914 m</p> <p>Range Area: 60 acres</p> <p>Safety Zone: Unknown</p> <p>Ordnance Types: Rocket, 35 mm, Subcaliber; Projectile, 40 mm; Small Arms</p> <p>Notes: Range 24 was used for small arms training, automatic rifle training, antitank (AT) 35mm subcaliber training, and practice 40mm grenade training. (Note that no removal action was conducted in the Multi-Range Impact Area.)</p>	

3.2 Factors Controlling MEC Distribution

For all weapon systems, the vertical MEC distribution is largely controlled by the physical properties of the ordnance and the impact location, as previously discussed. It is important to remember that the range may now appear much different than it did when the range closed because of vegetation growth or earth-moving and construction activity. What once was probably an area with little or no vegetation and direct line of sight from firing point to target areas may now have mature trees and be heavily overgrown.

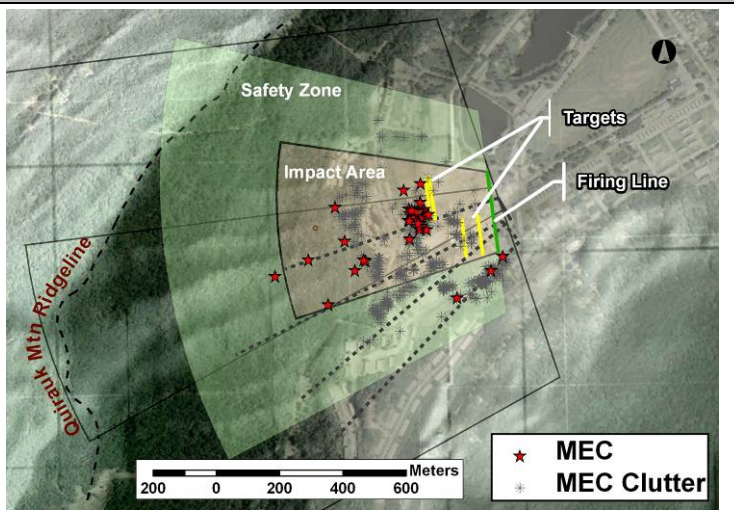
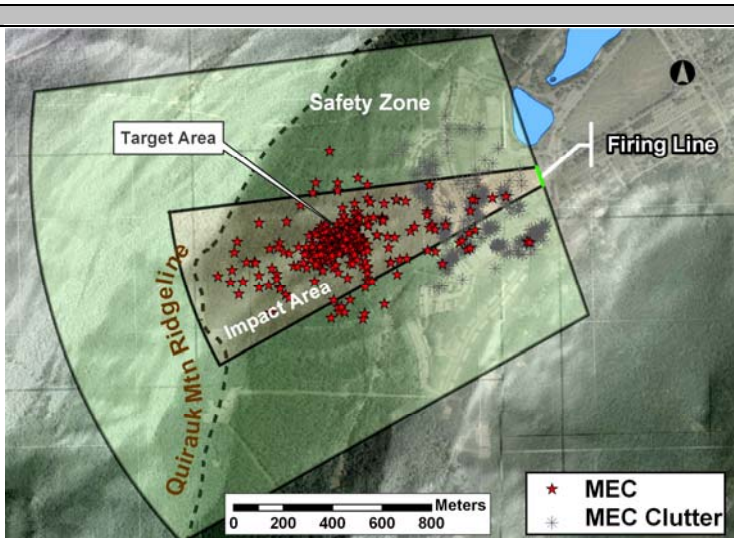
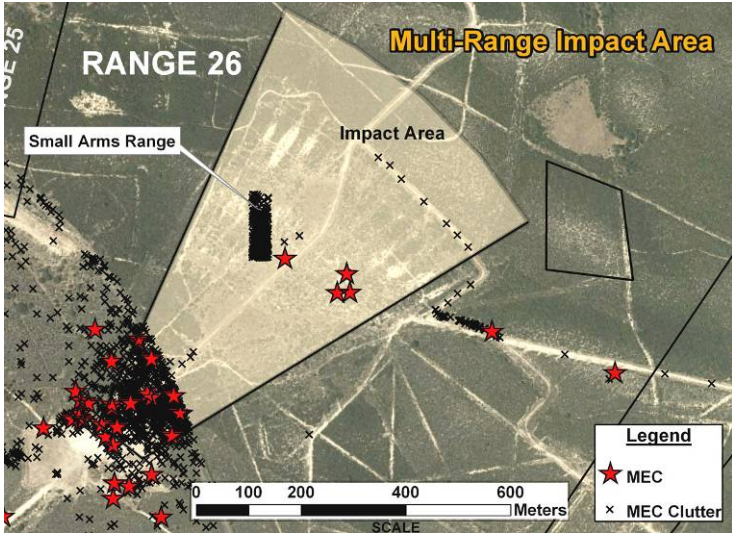
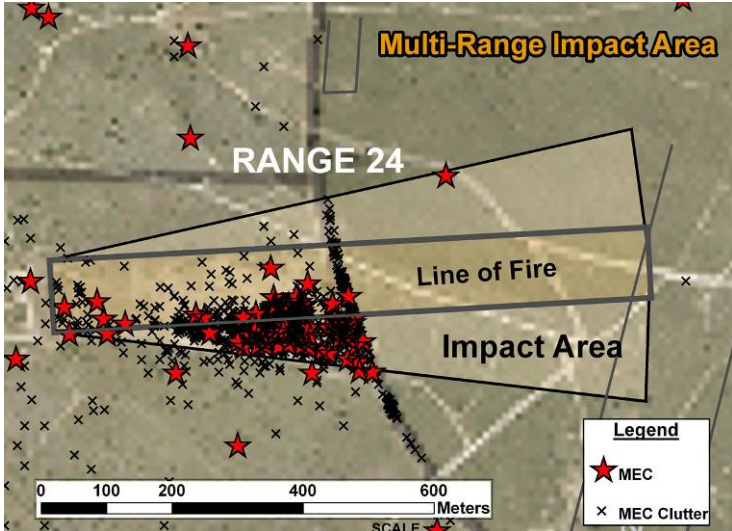
Direct-fire ordnance is typically fired at an angle that is nearly parallel to the land surface. Thus, it has a relatively flat trajectory and the angle of impact is typically lower than other types of weapon systems—such as mortars and artillery—unless a backstop is used behind the target. Because of the low angle of impact, one would expect to find ordnance at relatively shallow depths, and the likelihood for ricochets is higher. Physical actions such as frost heave and erosion are likely to expose the ordnance quicker than for indirect-fire ranges, as discussed in Section 4.

When a terrain feature functions as a backstop, the SDZ and ordnance distribution will be different than ordnance fired across flat terrain. For example, Figure 3-5 shows the standard design layout for a recoilless rifle range and the as-built drawings. Although the range was designed for level terrain, the actual location selected has a hill that cuts across the design layout, and the total area of the range as originally envisioned has been reduced by the hill which shortens the range by about 1,520 meters (5,000 feet) range and the hill acts as a backstop. The hill has a direct effect on the MEC distribution for direct-fire weapons by shortening the distance between the firing point and the potential points of impact. The hill may also increase the angle of impact if the slopes are steep. Thus, a team planning to characterize an MRA on this range could expect little or no MEC behind the hill. The team could also expect that penetration depths may be deeper on steep slopes facing the firing line. Depending on the stability of the slopes, erosion may have exposed and possibly even concentrated some MEC in drainages or buried the MEC beneath recent sediment. The hills also may impact the range-clearance effort by limiting the types of equipment that can be used because of the terrain. While the backstop effect may be an important factor for direct-fire weapons, it is not a consideration for indirect-fire systems, such as mortars or artillery, because they do not require line of sight to the target and terrain features such as hills have little or no influence on the SDZ, as discussed in Section 4.

Because of the line-of-sight requirement, the terrain selected for direct-fire weapon systems was typically minimized or managed to control masking of the targets by terrain or vegetation. An optimum site might be one that is located on gently sloping terrain where the firing points and target(s) are elevated relative to the terrain in between to enhance visibility and limit impacts to the SDZ. An example elevation profile for a direct-fire range is shown in Figure 3-6.

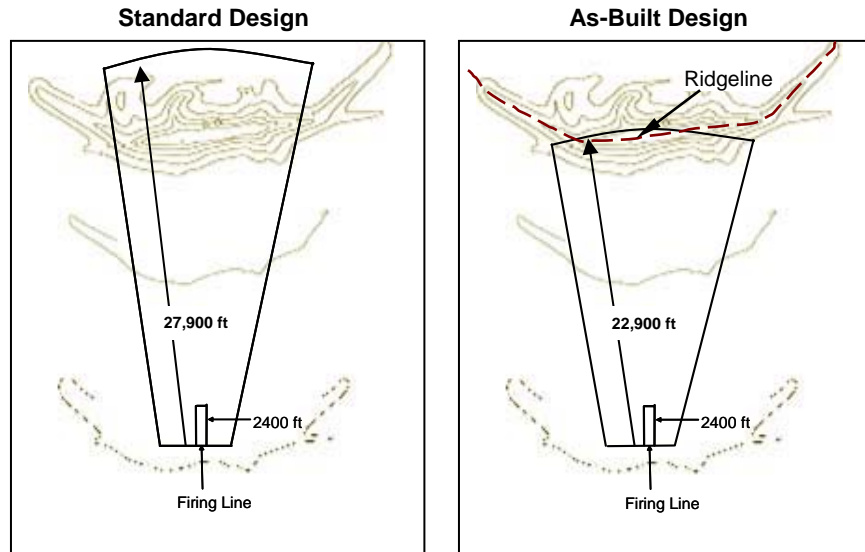

(Source: Modified from the USACE, EM 1110-1-1200)

Figure 3-5. Effect of Terrain on MEC Location and Size for a Direct Fire Recoilless Rifle Range

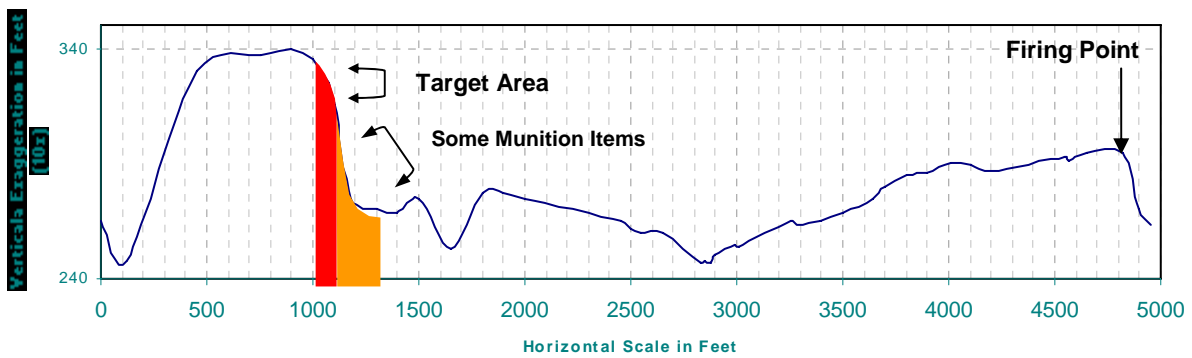

Source: Modified USACE-NewEngland, 2004, Fort Devins 37mm Range

Figure 3-6. Direct Fire Range, Cross Section Example

3.3 MEC Distribution

Theoretically, the ordnance distribution patterns from direct-fire weapons, such as anti-tank rockets, are expected to form ellipses that are highly elongated parallel to the line of fire, assuming relatively flat terrain. The amount of elongation is generally proportional to the range of the weapon and the target spacing used on the range. Because the weapons are fired from a fixed point or a line, a slight vertical sighting error (overshot or undershot) may result in impact that is hundreds or even thousands of meters from the target. Conversely, a sighting error that is slightly left or right of the selected target will often impact at about the same distance from the firing line regardless of the amount of left or right sighting error. Of course, in uneven terrain, the shape of the impact zone will reflect the site-specific geographic features of the range, and these could vary substantially from the hypothetical example provided.

Finally, ranges may be designed for one or more similar weapon systems, but use often changes over time as new weapon systems are developed and old systems are rendered obsolete. Direct-fire weapons—such as recoilless rifles—have maximum ranges that are 5 to 10 times the range of rifle grenades or rockets. Because it is possible that these weapon systems could be used on the same range or ranges, there could be overlapping SDZs and the MEC patterns could be several overlapping or offset ellipses.

Ordnance penetration depths may be estimated by calculating a theoretical penetration depth using several different methods, or they can be developed from empirical data collected during range surveys. Table 3-3 shows the theoretical penetration depths for direct-fire weapons.

Although not all of the penetration depth equations consider striking angle, some of the most commonly referenced tend to err on the conservative side and use maximum striking velocity and an angle of impact of 90° to establish a worst-case scenario. The equations for determining penetration depth vary from basic—which require only a few input parameters such as weight, velocity, and a soil penetration constant—to complex equations that require solving multidimensional equations and including additional variables such as ordnance geometry and striking angle.

The calculated penetration depths are generally deeper than the empirical depths encountered in range surveys. This pattern is expected because the calculated depths are very conservative and typically assume a worst-case scenario. Ordnance almost never reaches these depths in practice, unless subject to other events, such as impacting previous craters or being buried by earthmoving equipment. Conversely, the empirical data collected from range surveys may also be somewhat optimistic because ordnance items become more difficult to detect by surface geophysical techniques as the depth of the ordnance increases. Thus, the lack of ordnance below depths of about one meter (3.3 feet) may be a function of both the ability of the projectile to penetrate to deeper depths and the limits of the geophysical systems to detect the most common types of ordnance below this depth.

In the example anti-tank rocket range discussed above, the MEC distribution can be predicted using standard conditions and empirical data. In the case of the 2.36-inch anti-tank rocket, the weapon is fired at angles that are nearly parallel to the ground surface and the expected soil penetration depth is relatively shallow because the angle of penetration is low. The MEC distribution that can be expected for the 2.36-inch anti-tank rocket is typically less than 25 centimeters (10 inches) even when the rocket is fired at an angle normal to the land surface. Thus, MEC from this weapon system would be expected to be very near or on the land surface. However, it is important to consider how site conditions may have changed over time because they may affect the MEC distribution, as previously discussed. For example, if the soil has been eroded or disturbed by manmade activities, the MEC could either be exposed on the land surface or buried beneath soil deposited by erosion or earth-moving activities. An awareness of any activities (manmade and natural) that may have affected the MEC distribution subsequent to range closure is critical in the clearance process. MEC may be found at depths greater than expected or in unexpected locations if the manmade or natural processes have greatly affected the range.

Table 3-3. Theoretical Penetration Depths for Direct-Fire Ordnance

Ordnance Item	Depth of Penetration (meters/feet)			
	Limestone	Sand	Soil Containing Vegetation	Clay
37mm M63 ²	0.18 / 0.6	0.4-1.19 / 1.3 ³ - 3.9	1.59 / 5.2	2.41 / 7.9
37mm M54 ² (short)	0.09 / 0.3	0.58 / 1.9	0.76 / 2.5	1.16 / 3.8
57mm M308A1 ¹	0.12 / 0.4	0.82 / 2.7	1.07 / 3.5	1.68 / 5.5
75mm M48 ²	0.21 / 0.7	0.48-1.49 / 2.8 ³ - 4.9	1.98 / 6.5	3.01 / 9.9
2.36-inch Rocket ²	0.03 / 0.1	0.12 / 0.4	0.15 / 0.5	0.24 / 0.8
Rifle Grenade M9 ⁴		0.03 / 0.1	0.06 / 0.2	0.06 / 0.2

¹Source: Fax data from USACE, Baltimore District to ICF Kaiser 10 July 1998; subject-matter expert Michelle Crull

²USACE, 2004

³Striking angle of 30°

⁴USACE, 200b, EM 1110-1-4009, worst-case scenario

Example site case studies of direct fire range installations including range layouts and summaries of MEC and clutter items found in munitions investigation or removal actions are presented in Appendix A.

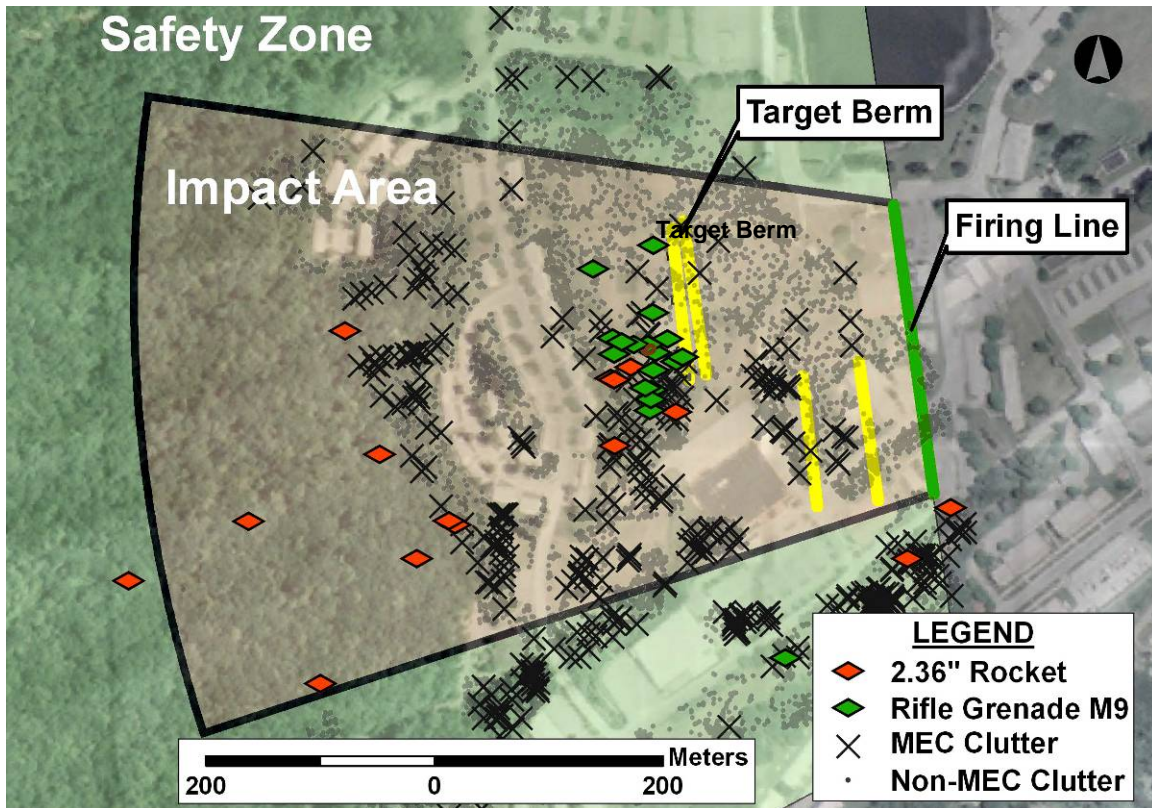

(Note - Only direct fire MEC items are shown in this map plot.)

Figure 3-7. Example of Direct Fire Range at Fort Ritchie Showing MEC Distribution

SECTION 4 - INDIRECT-FIRE RANGES

4.1 General Description

For an indirect-fire weapons system, line-of-sight between the gun and the target is not required. Indirect-fire weapons include artillery, field guns (howitzers), and mortars. The artillery divisions of an army control the bigger, long-range weapons, formerly referred to as cannons. The role of artillery is to provide fire support for the infantry, cavalry, armored, and other divisions. Common mortars are 60mm, 81mm, and 3-inch Stokes. Common howitzers are the 75mm pack, 105mm, 155mm, 8-inch, and 240mm.

Forward observers are often used to spot the impacting rounds and relay the information back to the firing point so that adjustments can be made. Because indirect-fire weapons do not require line of sight between the firing point and the target and the projectiles have a relatively high trajectory, they can fire over hilly terrain and dense vegetation. The use of topography for a backstop would only be appropriate where the elevation and distances were adequate to ensure that the ordnance could not be inadvertently fired over the peak beyond the SDZ. Figure 4-1 shows the trajectory and approximate angle of impact on flat terrain for a mortar and cannon. There are no characteristics pertaining to indirect-fire weapon systems or their use that would cause proposed land use to be notably different than other types of weapon systems.

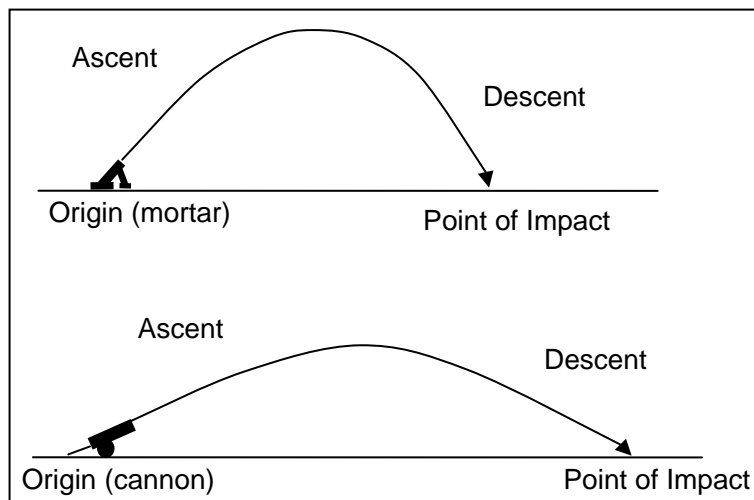
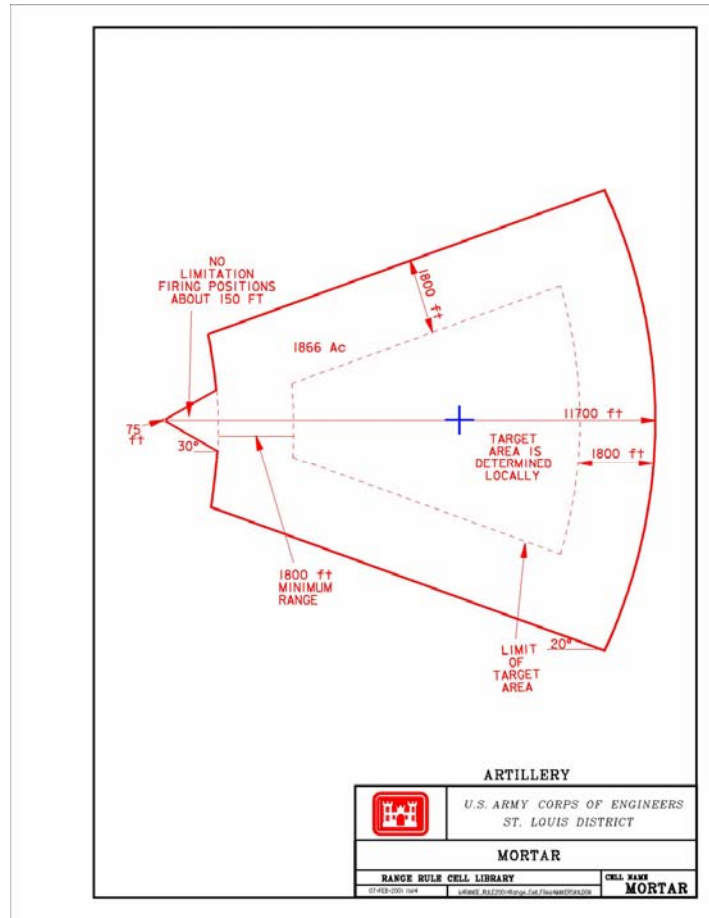

Figure 4-1. Typical Trajectory of Indirect Fire Weapons

Historically, precision development progressed more slowly for indirect-fire weapons because hitting an unseen target requires refinements in the ability to locate both the target and the firing position, as well as the ability to accurately predict the ballistic course of a projectile. For the same reasons, the precision of rounds fired during every training mission progress towards the target as information is received from forward observers and corrections are made to adjust for climatic conditions. Training missions would typically have been conducted with numerous howitzers or mortars that make up a battery or platoon.

Some ordnance could be fired in both a direct and indirect manner, such as the 75mm HE, M48 (used in both a gun and pack Howitzer), which would have affected penetration depth. The distances between firing points and targets are determined by the weapon system engagement parameters: range, lethality, use, area targets (or personnel), and terrain. A typical layout (historical) for an indirect-fire weapons (mortar) system is shown in Figure 4-2. The targets are usually placed at known distances from the firing points. The range's dimensions depend on the munitions used and cannot be a set distance.



Source: USACE–St. Louis, 2002

Figure 4-2. Mortar Range SDZ

Indirect-fire ranges are designed in similar manner to direct-fire ranges; however, there is no ricochet area because the steep angle of impact limits ricochets (see the mortar range shown in Figure 4-2). This range has three areas of concern: the firing point (firing line), the impact area, and the danger area. The firing line is an arbitrary line established by the local requirements, but 23 meters (75 feet) would generally be sufficient. The impact area (target area), also determined by local requirements, would begin a minimum of 550 meters (1,800 feet) from the firing point and continue down-range the maximum range of the mortars fired. The SDZ was derived by estimating the right and left limits of fire and the downrange distance. In this example, the estimated angle of fire is 30°. The downrange distance of the cell was based on an 81mm HE, M43 mortar as a worst-case scenario; this mortar has a maximum range of 3,020 meters (9,900 feet). Regulations required an additional 1,800-foot danger area applied to each side and to the

downrange distance (USACE–St. Louis, 2002). Table 4-1 lists probable ordnance types and the maximum range distances for indirect-fire weapon system used historically during the World War II buildup and post-war. Example images and diagrams for many of these ordnance types can be found in Appendix E.

Table 4-1. Indirect Fire Ranges and Probable Ordnance Types (WWII Era)

Range Name	Probable Weapon and Ordnance Type	Maximum Range		Max Standard Acreage
		Meters	Yards	
Artillery	75mm gun – Shrapnel ¹ , Mk1	8,915	9,750	22,917
	75mm pack Howitzer – HE M48	8,961	9,800	
Artillery	105mm Howitzer M2, HE, M1	11,110	12,150	
	105mm Howitzer M2, Smoke, M84	11,165	12,210	
	105mm Howitzer, M3, HE, M1	7,763	8,490	
Artillery	155mm Howitzer, M1917-18, HE M105	11,681	12,775	69,314
	155mm Howitzer, M1917-18, Shrap, Mkl	9,921	10,850	
	155mm Howitzer, M1, HE, M107	14,630	16,000	
	155mm Howitzer, M1, HE, M101	23,226	25,400	
Artillery	4.5-inch gun, M1, HE	19,317	21,125	
	8-inch Howitzer HE, Mkl	11,613	12,700	
Artillery	240mm Howitzer, HE, MkII	14,996	16,400	
Mortar	60mm, Training	320	350	1,866
	60mm, Practice and HE	1,769	1,935	
	60mm, Smoke	1,473	1,610	
	60mm, Illumination	1,006	1,100	
Mortar	81mm, Training	320	350	
	81mm, Practice and HE	3,018	3,300	
	81mm, Smoke	2,259	2,470	
	81mm, Illumination	2,103	2,300	
Mortar	3-inch Stokes	686	750	

Source: Modified from USACE-St. Louis, 2002

¹Some 75mm configurations e.g., M48 can be used in either direct- and indirect-fire mode

Figure 4-3 shows the standard range layouts associated with these range types. Length and area dimensions of the Artillery range depend on the type of munition used. Detailed descriptions of these range designs can be found in Appendix D. Examples of actual direct fire ranges are presented in Table 4-2 with known or estimated range sizes and ordnance types found or suspected to be present.

4.2 Factors Controlling MEC Distribution

For all weapon systems, the vertical MEC distribution is largely controlled by the physical properties of the ordnance and the impact location, as previously discussed. It is important to remember that the range may now appear much different than it did when the range closed because of vegetation growth or earth-moving and construction activity. What once was probably an area with little or no vegetation and direct line of sight from firing point to target areas may now have mature trees and be heavily overgrown.

Ordnance areal dispersion and vertical penetration depth show some recognizable trends depending on the use profile, including the type of weapons system(s) used, the duration of use, the firing positions, the range maintenance history, the physical features addressed below, and prior UXO investigations and removal actions. Theoretically, the ordnance distribution should be most dense around the target area and decrease in density with distance from the target area.

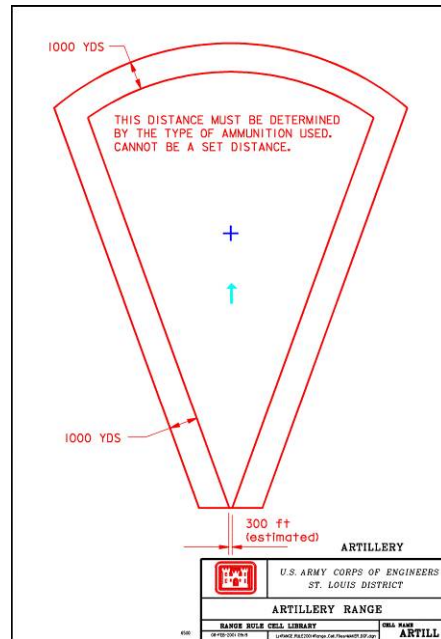

Artillery (Size varies by munition/weapon.)

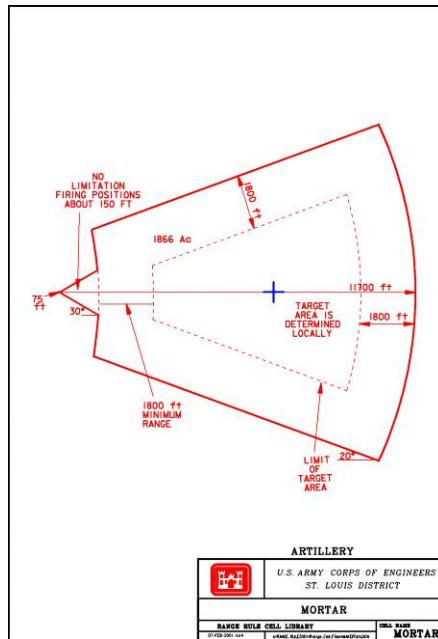

Mortar

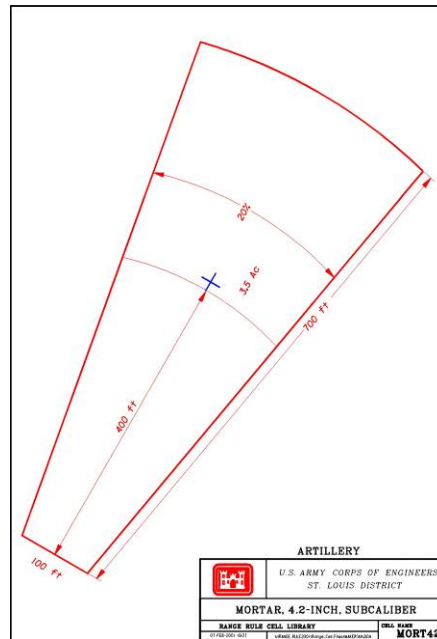

Mortar, 4.2", Subcaliber

Source: USACE–St. Louis, 2002

Figure 4-3. Standard Indirect Fire Range Diagrams

Table 4-2. Range Examples – Indirect Fire

Description	Range Diagram or Photo
<p>Site: Adak NAF, AK</p> <p>Range Name: Mitt Lake Mortar Range</p> <p>Range Type(s): Mortar</p> <p>Target Distance: 1980 m (center of mortar impact area)</p> <p>Range Length: 2600 m (estimated)</p> <p>Range Area: 15 acres (mortar target area) 588 acres (range fan, estimated)</p> <p>Safety Zone:</p> <p>Ordnance Types: Mortar, 60 mm Projectile, 20 mm</p> <p>Notes: Mortar impact area backstopped by mountain ridge. Range area also includes 20 mm projectile range.</p>	 <p>The diagram shows a topographic map of the Mitt Lake area. A dashed line represents the firing line, extending from a 'Firing Point' on the right towards a 'Target Area' on the left. The 'Impact Area' is shown as a fan-shaped region between the firing line and the target area, containing several red stars (MEC) and black crosses (MEC Clutter). A legend in the bottom right corner identifies the symbols: a red star for MEC, a black cross for MEC Clutter, and a black dot for Non-MEC Clutter. A scale bar at the bottom indicates distances up to 1,500 meters.</p>
<p>Site: Fort Ritchie (MD)</p> <p>Range Name: Quirauk Mountain Hillside</p> <p>Range Type(s): Artillery, 37 mm; Mortar</p> <p>Target Distance: 850 m (based on found-MEC pattern)</p> <p>Range Length: 1495 m (estimated based on distance to Quirauk Mountain ridgeline)</p> <p>Range Area: 135 acres (estimated)</p> <p>Safety Zone: 772 acres (estimated)</p> <p>Ordnance Types: Projectile, 37 mm; Mortar, 60 mm, 81 mm, 3" Stokes, 50 mm Japanese "Knee"</p> <p>Notes: Estimated SDZ's overlaid based on documented firing points, target distance, and munitions used.</p>	 <p>The diagram is an aerial photograph of the Quirauk Mountain area. A 'Firing Line' is shown on the right, pointing towards a 'Target Area' on the left. The 'Impact Area' is a cluster of red stars (MEC) within the target area. A 'Safety Zone' is outlined as a larger area surrounding the impact area. A 'Quirauk Mtn. Ridgeline' is labeled along the left side of the impact area. A legend in the bottom right corner identifies the symbols: a red star for MEC and a black cross for MEC Clutter. A scale bar at the bottom indicates distances up to 800 meters.</p>

Table 4-2. Range Examples – Indirect Fire (Continued)

Description	Range Diagram or Photo
<p>Site: Tobyhanna Artillery Range, PA</p>	
<p>Range Name: Northeast Range Area</p>	
<p>Range Type(s): Artillery</p>	
<p>Target Distance: 1900 m (FP1 – T1) 4250 m (FP1 - T4)</p>	
<p>Range Length: 2970 m (FP1 – T1) 5300 m (FP1 – T4)</p>	
<p>Range Area: 1050 acres (FP1 – T1) 1680 acres (FP1 – T4)</p>	
<p>Safety Zone:</p>	
<p>Ordnance Types: Projectiles, 37 mm, 75 mm, 155 mm; Projectile, 3-lb</p>	
<p>Notes: Range operated from 1912 to about 1949. Each firing point (FP) consisted of (4) 75 mm/3" French guns/Howitzer and (1) 155 mm gun. (Map modified from Weston, 2004)</p>	
<p>Site: Camp Edwards, Massachusetts Military Reservation (MMR), MA</p>	
<p>Range Name: J-Range #1</p>	
<p>Range Type(s): Artillery; Mortar</p>	
<p>Target Distance: 1000m berm ; 2000m berm</p>	
<p>Range Length: 2000 m</p>	
<p>Range Area: 60 acres</p>	
<p>Safety Zone:</p>	
<p>Ordnance Types: Projectile, 105 mm, 57 mm, 37 mm; Mortars (60 mm, 81 mm)</p>	<p>Notes: A 150-meter fixed firing position is adjacent to the 1,000-meter berm. The end of the range lies within a central multi-range impact area. The ranges were used mainly for testing weapons. (Map modified from USACE-New England, 2003)</p>

Table 4-2. Range Examples – Indirect Fire (Concluded)

Description	Range Diagram or Photo
Site: Badlands Bombing Range, SD	
Range Name: Artillery Impact Area (Air Force Retained Area)	
Range Type(s): Artillery, Howitzer (155 mm and 8" Projectiles)	
Target Distance: 10,200 m (measured from most distant FP location to approximate center of impact area)	
Range Length: 12,900 m (measured from most distant FP location to far edge of buffer zone)	
Range Area: 2,486 acres	
Safety Zone: 6790 acres (impact area + buffer zone) 17,880 acres (all areas including FP's)	
Ordnance Types: Projectile, 155 mm; Projectile, 8-inch	
Notes: Used by South Dakota National Guard for artillery training. Area also contains bombing targets and rocket range.	

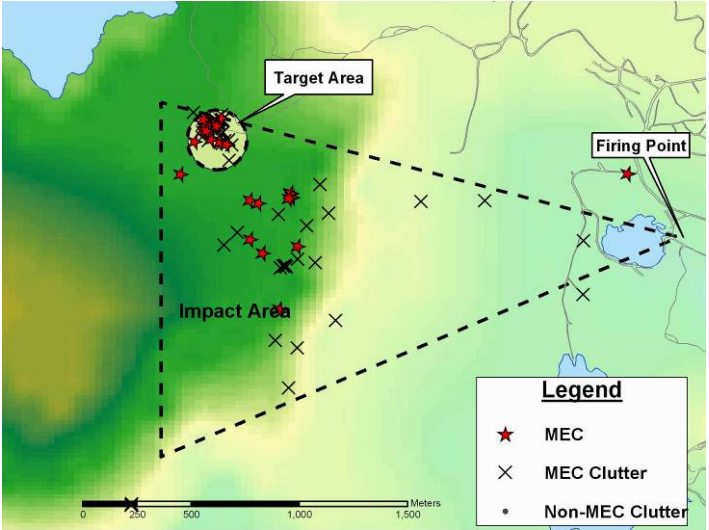
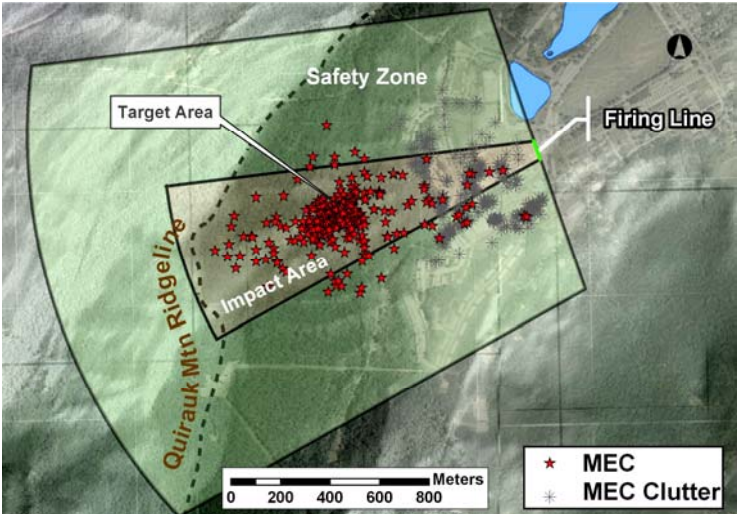
The depth ordnance will penetrate depends on the ordnance shape, weight, angle of impact, velocity, materials of construction, and soil type. In general, soil density and grain size are both inversely proportional to the penetration depth, while water content and the angle of penetration are both directly proportional to the penetration depth. Thus, penetration depth is greatest when the soils are fine-grained and saturated and the angle of penetration is near vertical. Penetration depths are lowest when the soils are dry and coarse-grained and the entry angle is low.

Indirect-fired ordnance is typically fired at a moderate to high angle to the land surface. Thus, it has an arching or curved trajectory and the angle of impact is typically higher than for direct-fire weapons, such as machine guns and other small arms. Relative to direct-fire ordnance, indirect fire ordnance is typically larger and impacts at a higher angle. Therefore, indirect-fire ordnance can be expected to be found at deeper depths, and the likelihood for ricochets is lower. Physical actions such as frost heave and erosion are likely to expose the ordnance more slowly than for direct-fire ranges.

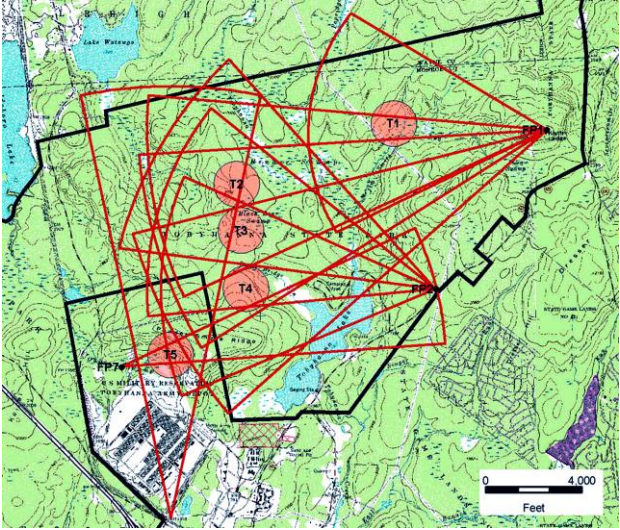
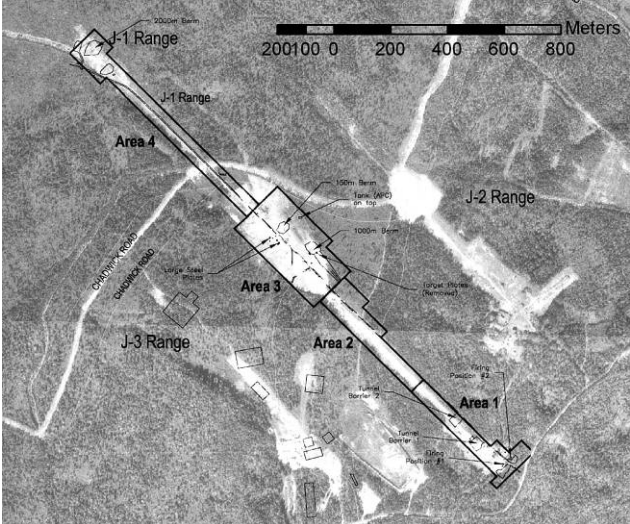
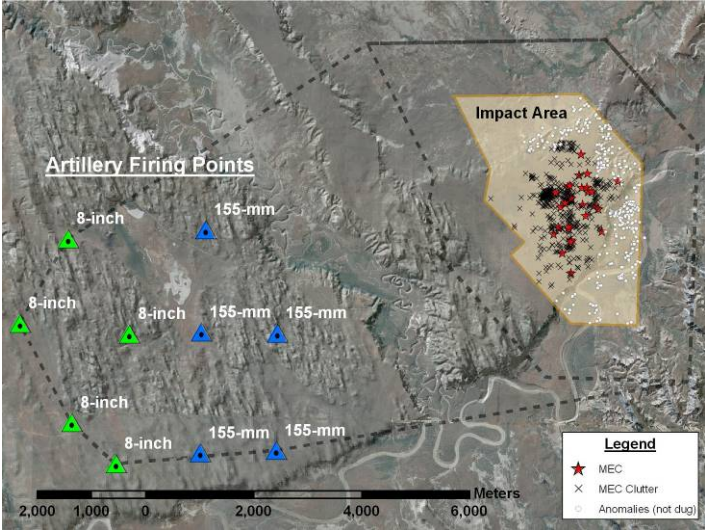
Table 4-3 shows theoretical penetration depth for indirect-fire ordnance. The table contains data developed by USACE Waterways Experiment Station (WES) (USACE, 2004) using a “normal” striking angle and 30° angle, as well as data published in EM 1110-1-4009 that uses worst case conditions, such as maximum velocity and striking angle 90° to ground surface. For example, the data in Table 4-3 shows that the 81mm mortar has an expected penetration depth of 0.82 meters (2.7 feet) in sand, 1.07 meters (3.5 feet) in loam, and 1.65 meters (5.4 feet) in clay, assuming worst-case conditions where the impact is perpendicular to the ground and the projectile hits the ground at its maximum velocity. Typical penetration depths are expected to be somewhat less.

Table 4-3. Theoretical Penetration Depth for Indirect Fire Ordnance

Ordnance Item	Depth of Penetration (meters/feet)			
	Limestone	Sand	Soil with Vegetation	Clay
60mm mortar ¹	0.06/0.2	0.34/1.1	0.46/1.5	0.70/2.3
75mm M48 ²	0.21/0.7	0.86-1.5/2.8 ³ -4.9	1.98/6.5	2.1-3.1/7-10
81mm Mortar ¹	0.12/0.4	0.82/2.7	1.07/3.5	1.65/5.4
105mm M1 ²	0.34/1.1	1.13-2.35/3.7 ³ -7.7	3.08/10.1	4.7/15.4
155mm M107 ²	0.61/2	1.55-4.27/5.1 ³ -14	5.61/18.4	8.5/28
8-inch M106 (charge 8) ³		5/16.4	7.38/24.2	11.3/36.9
60mm M49A1 (charge 4) ⁴		0.34/1.1	0.46/1.5	0.70/2.3
81mm M43A1 (charge 8) ⁴		0.82/2.7	1.07/3.5	1.65/5.4
3-inch Stokes mortar ¹	0.09/0.3	0.64/2.1	0.85/2.8	1.31/4.3
4.2-inch mortar M3 (max charge) ⁴		1.25/4.1	1.65/5.4	2.53/8.3

¹Fax data from USACE, Baltimore District to ICF Kaiser 10 July 1998; subject-matter expert Michelle Crull

²USACE, 2004

³Striking angle of 30°

⁴USACE, 200b, EM 1110-1-4009, worst-case scenario, normal striking angle

4.3 MEC Distribution

The theoretical MEC distribution from indirect-fire weapons would generally be a slight elliptical pattern as compared to the highly elliptical pattern for direct-fire weapons on flat terrain. Because the weapon systems are fired from a point or a line, the direction of fire towards the target area would result in a range probable error (error long and short of the target) that is greater than the deflection probable error (error right and left of the target). The ellipses would theoretically converge into a circular pattern if they were evenly spaced 360° around the target area, assuming each firing point was used equally. Clearly, the MEC pattern associated with indirect-fire weapons is likely to be much more circular in appearance.

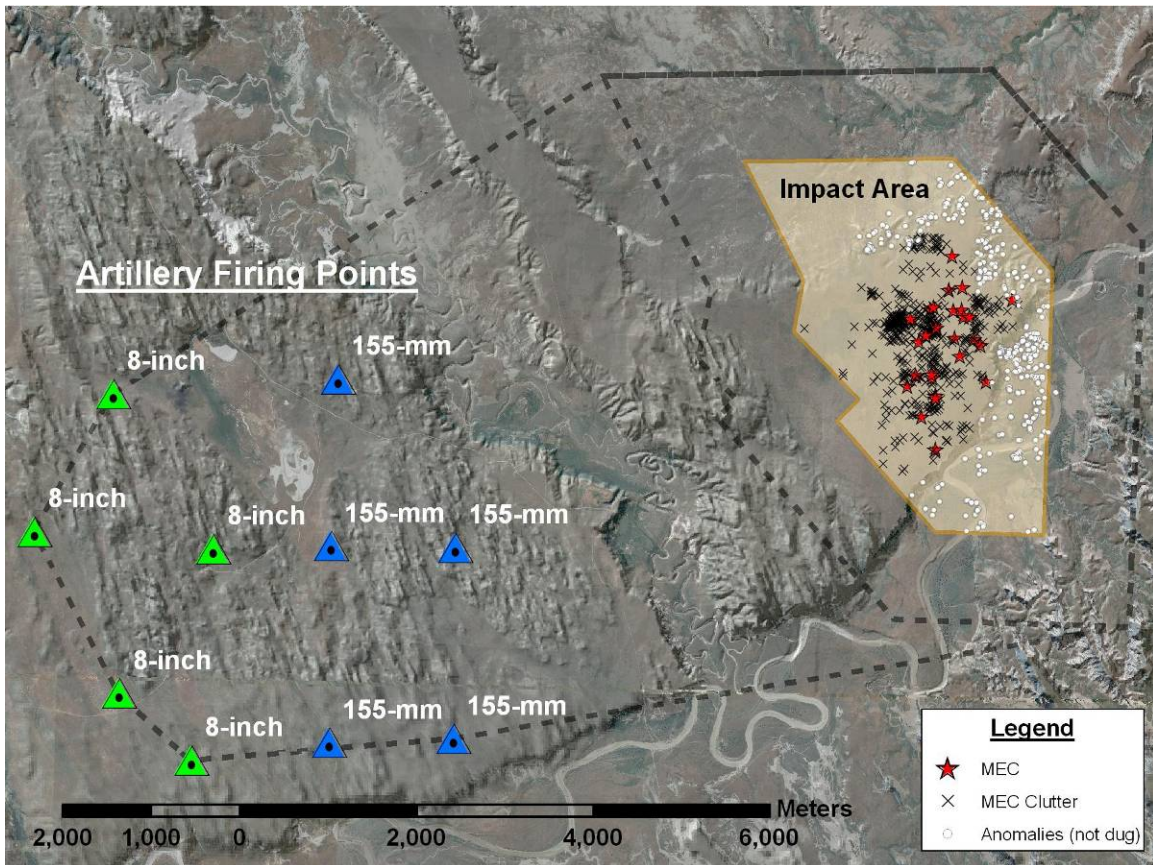

Source: Map plot based data from Nelson, et al., 2003 and archive range map from USACE-Rock Island, 2000.

Figure 4-4. Example of Artillery Range at Badlands Bombing Range Showing MEC Distribution in Impact Area

Example site case studies of indirect fire range installations including range layouts and summaries of MEC and clutter items found in munitions investigation or removal actions are presented in Appendix B.

SECTION 5 - BOMBING AND GUNNERY RANGES

5.1 General Description

Live and practice bombing and gunnery targets were typically designed to be seen and read from the air. Thus, the topography had to be relatively flat and clear of vegetation. Air-delivered bombing ranges generally consisted of circular or square target areas within a common impact area. Such ranges were also often used for air-to-ground rocket firing and gunnery. Some ranges were specifically design for air-to-ground rockets and strafing and were generally oblong in shape. Figure 5-1 shows a photo of a typical bombing target design located at the Fort Sill, Oklahoma, Falcon Range



Figure 5-1. Bombing Target, Falcon Range, Fort Sill, Oklahoma

Because these ranges require a relatively flat and wide area, the land would be desirable for most types of reuse because of the relatively minimal amount of earth movement needed to establish a flat building site. For similar reasons, these ranges may also be desirable for agricultural use.

The typical weapons used at these ranges consisted of old-style general-purpose bombs, general-purpose HE-filled 100 lb bombs (AN-M30), and 250 lb bombs (AN-M57 and AN-M57A1). In addition to live bombs, several types of practice bombs were also used, including 100 lb practice bombs (M38A2, M85, Mk 15 Mod 3, Mk15 Series) and 500 lb practice bombs (Mk 5, Mk 15, and Mk21). Practice bombs with a spotting charge (M1A1) were also used in training. Typical practice and live bombing ranges are discussed below.

Bombing Target—Practice

The range area was designed to be sufficiently large so that the center of any target placed on it would be a minimum of 760 meters (2,500 feet) from the range boundary. For bombing from 7,600 meters (25,000 feet) and above, a 1,520-meter (5,000-foot) radius was advisable. The typical and widely used target design consisted of a series of concentric circles with four legs indicating north/south and east/west. Four reference squares were placed along each leg at 30-meter (100-foot) intervals to facilitate scoring. For the purpose of indicating True North, the north leg was extended within the 30-meter circle towards the target center—a distance of 12 meters (40 feet). At the extreme end of the north leg, a numeral 23 to 46 meters (75–150 feet) was set with its base towards the center of the target. For bombing above 4,600 meters (15,000 feet), inscribing was recommended for only the 60-meter and 150-meter (200- and 500-foot) circles. The legs and concentric circles of the target were constructed of crushed rock or dirt sprayed with white paint, whitewash, or a contrasting color to the surrounding soil. In the center of the target circle, a pyramid—3.5 meters (12 feet) high with a base approximately 9 by 9 meters (30x30 feet)—was constructed of native earth or wood and was whitewashed. Target lighting was provided by mounting light bulbs on 2.5-meter (8-foot) high poles, at 7 meter (22-foot) intervals around the circle. Lights were also mounted at each of the four legs intersecting the 30-meter (100-foot) circle. Numerals were also illuminated with light bulbs.

Although MEC items will be concentrated around the target, evidence of bombing is almost always found beyond the scoring arcs. MEC debris is typically found throughout the entire property and occasionally beyond the property boundaries. The range cell area was calculated to extend beyond the target center about 900 meters (3,000 feet), for a total of 649 acres. Many factors—all of which are unknown, such as altitude and flight speed—affect targeting accuracy. From studies completed in World War II, 99 percent of the bombs should be found within 900 meters (3,000 feet) for bombers flying at 4,600 meters (25,000 feet) or below and at speeds up to 400 kph (250 mph). The same study implied a 600-meter (2,000-foot) radius should include 95 percent of the bombs under the same conditions (USACE–St. Louis, 2002).

Bombing Target—Live

The purpose of using a range for tactical bombs was to familiarize students with handling and releasing combat munitions. The range area—adequate for use with 100-lb demolition bombs below 4,600 meters (15,000 feet)—was a minimum of 1.5 square miles with a centrally located target. The target was a cross-shaped ground area scraped free from vegetation and whitewashed. A night target was not used on this type of range. Although MEC will be concentrated around the target, evidence of bombing is almost always found beyond the scoring arcs. MEC debris is typically found throughout the entire property and occasionally beyond the property boundaries. The range cell area was calculated to extend 900 meters (3,000 feet) beyond the target center, for a total of 649 acres. Figure 5-2 depicts the SDZ for a bombing target (live) (USACE–St. Louis, 2002). The bombing target in Figure 5-1 at the Fort Sill, Oklahoma, Falcon Range has 23- and 45-meter circles comprised of white painted tires; the outside diameter of the vegetation-free circle is 91 meters. The Falcon range is 7,000 acres, with an additional 7,000 acres under military jurisdiction.

Probable ordnance for bombing and gunnery ranges used historically during the World War II buildup and post-war are listed in Table 5-1. Example images and diagrams for many of these ordnance types can be found in Appendix E.

Figure 5-2 shows the standard range layouts associated with the generic bombing and gunnery range types. Further descriptions of these standard range designs can be found in Appendix D. Examples of actual bombing and gunnery ranges are presented in Table 5-2 with known or estimated range sizes and munitions types found or suspected to be present.

Table 5-1. Bombing Ranges and Probable Ordnance Types (WWII Era)

Range Name	Probable Weapon and Ordnance Type	Weight (lbs)	Standard Acreage
Bombing Target, Practice	AN-Mk5 and AN-Mk 23 (3 lb miniature bombs, 55mm diameter, 210mm length, AN-Mk4 or AN Mk5 spotting charge – 10g shotgun shell)	3	649
	AN-Mk 43 (4.5-lb miniature practice bomb, 55mm diameter, 210mm length, AN-AN Mk4 10g shotgun shell signal)	4.5	
	AN-M41A1, practice bombs		
	M38A2, practice bomb	100	
	Mk85, practice bomb	100	
	Mk 15, Mod 3, practice bomb	100	
	Mk 15 series, practice bomb	100	
Bombing	Mk5, Mk 15, Mk21 practice bombs	500	649
	Spotting Charge, M1A1		
	Bomb, General purpose, old style	100 – 1,000	
Rocket, Air-to-Ground	AN-M30, General Purpose Bomb	100	3108
	AN-M57, AAN-M57A1, general purpose bombs	250	
	3.5-inch, Rocket, Aircraft, Mk4		
	5-inch, Rocket, Aircraft, HVAR		
Air-to-Ground Gunnery	2.25-inch Rocket, Aircraft, Practice		640
	2.75-inch Rocket, Aircraft, Practice, FFAR		
	Projectile, 20 mm		
	Small arms		

Source: USACE-St. Louis, 2002

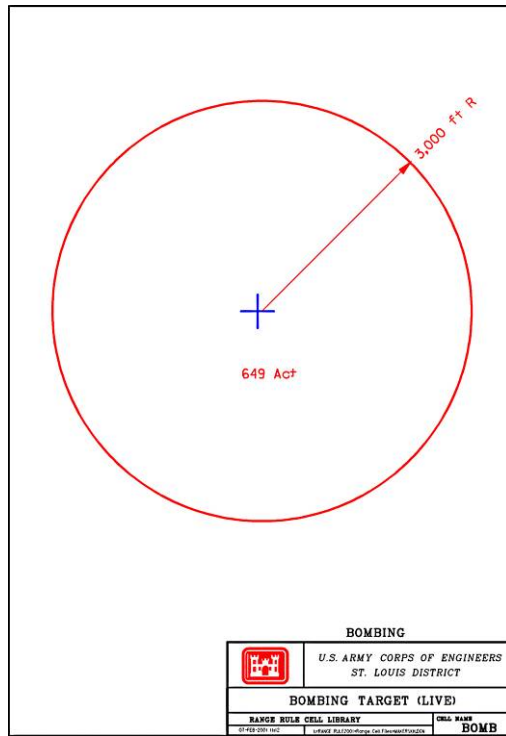

Bombing (Live; Practice)



Air-to-Ground Gunnery

Source: USACE–St. Louis, 2002

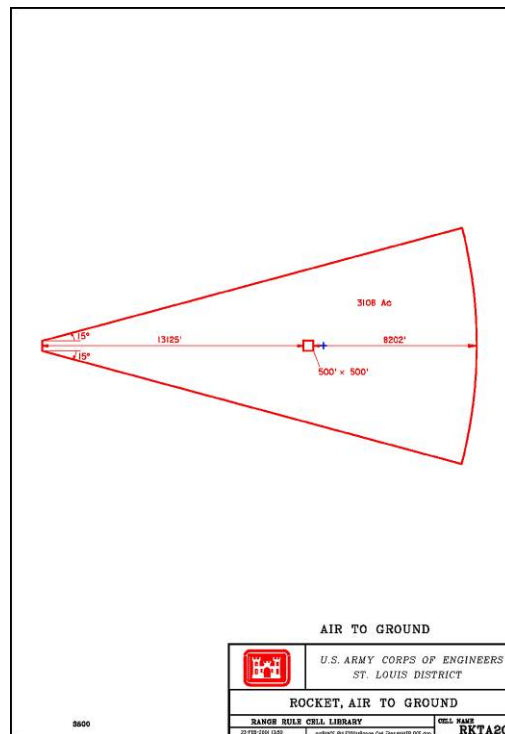

Air-to-Ground Rocket

Figure 5-2. Standard Bombing and Gunnery Range Diagrams

Table 5-2. Range Examples – Bombing and Gunnery

Description	Range Diagram or Photo
<p>Site: Badlands Bombing Range, SD</p> <p>Range Name: Cuny Table Target #1</p> <p>Range Type(s): Bombing, Practice; Bombing, Live (?); Air-to-Ground Rocket, Air-to-Ground Gunnery</p> <p>Target Radius: 722 m (outer ring)</p> <p>Impact Area: 405 acres (estimated based on outer ring)</p> <p>Safety Zone:</p> <p>Ordnance Types: Bomb, 100-lb, Practice, M38; Bomb, Incendiary, M50; Rocket, 2.25", SCAR; Rocket, 2.75", FFAR; Projectile, 20 mm</p>	
<p>Notes: Largest of the Cuny Table Targets. Target consists of a series of concentric rings. The outermost ring is approximately 1444 m in diameter. (1954 ASCS Aerial Photo, Shannon Co., SD)</p>	
<p>Site: Badland Bombing Range, SD</p> <p>Range Name: Cuny Table Target #2</p> <p>Range Type(s): Bombing, Practice; Air-to-Ground Rocket, Air-to-Ground Gunnery</p> <p>Target Radius: 300 m (outer ring)</p> <p>Impact Area: 69 acres (estimated based on outer ring)</p> <p>Safety Zone:</p> <p>Ordnance Types: Bomb, 100-lb, Practice, M38; Rocket, 2.75", FFAR; Projectile, 20 mm</p>	
<p>Notes: Target consists of a series of concentric rings with the outermost ring approximately 600 m in diameter. (1954 ASCS Aerial Photo, Shannon Co., SD)</p>	

Table 5-2. Range Examples – Bombing and Gunnery (Continued)

Description	Range Diagram or Photo
<p>Site: Badlands Bombing Range, SD</p> <hr/> <p>Range Name: Bouquet Table Target</p> <hr/> <p>Range Type(s): Bombing , Practice</p> <hr/> <p>Target Radius: 236 m (outer ring)</p> <hr/> <p>Impact Area: 43 acres (estimated based on outer ring)</p> <hr/> <p>Safety Zone:</p> <hr/> <p>Ordnance Types: Bomb, 100-lb, Practice, M38; Bomb, 3-lb, Practice, Mk23; Projectiles, 20 mm</p>	
<p>Notes: The target is a series of concentric rings, the largest of which is about 472 m in diameter with a cross marking the bulls-eye. (USDA-FSA-APFO, 2005)</p>	
<p>Site: Pueblo of Laguna, NM</p> <hr/> <p>Range Name: N-10</p> <hr/> <p>Range Type(s): Bombing, Practice</p> <hr/> <p>Target Radius: 150 m (outer ring)</p> <hr/> <p>Impact Area: 17 acres (estimated based on outer ring)</p> <hr/> <p>Safety Zone:</p> <hr/> <p>Ordnance Types: Bomb, 100-lb, Practice (M38, M75)</p>	
<p>Notes: Target marked with 4 concentric rings. NW of the target is a man-made feature in the shape of a "T", designed as a visual guide to pilots. Practice bombs likely were all dropped from high-speed aircraft.</p>	

Table 5-2. Range Examples – Bombing and Gunnery (Continued)

Description	Range Diagram or Photo
<p>Site: Lowry Bombing and Gunnery Range (Buckley Field), CO</p> <p>Range Name: Bombing Target #2</p> <p>Range Type(s): Bombing, Practice; Air-to-Ground Rocket; Bombing, Live</p> <p>Target Radius: 468 m (outer rectangular boundary) 165 m (inner ring)</p> <p>Impact Area: 177 acres (based on rectangular boundary)</p> <p>Safety Zone:</p> <p>Ordnance Types: Bomb, 100-lb, Practice, M38; Bomb, 3-lb, Practice, Mk23; Rocket, 2.25", SCAR; Bomb, Incendiary (4-lb, 10-lb)</p> <p>Notes: Detailed summary in Appendix. (Image Source: http://www.flbgr.org/AOC_status_maps/07-Bombing_Target_2.html)</p>	
<p>Site: Lowry Bombing and Gunnery Range (Buckley Field), CO</p> <p>Range Name: Air-to-Ground Gunnery Range Artillery, 75 mm</p> <p>Range Type(s): Air-to-Ground Gunnery</p> <p>Range Length: 4680 m x 1270 m</p> <p>Impact Area: Multiple (areas unknown)</p> <p>Safety Zone: 1360 acres (estimated based on rectangular boundary)</p> <p>Ordnance Types: Bomb, Photoflash, 40 mm, Bomb, 3-lb, Practice, Mk23, Rocket, 2.25" and 2.75", Projectile, 37mm; Projectile, 75mm; Other practice and live bomb types likely present.</p> <p>Notes: Area comprised of at least three air-to-ground rocket and/or gunnery targets, plus two ground fixed gunnery targets along central N-S axis. (Image Source: http://www.flbgr.org/AOC_status_maps/05-Air_To_Ground_Gunnery.html)</p>	

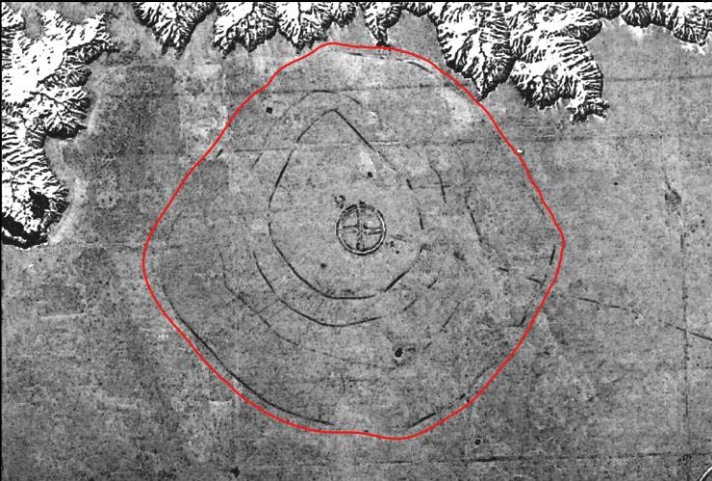
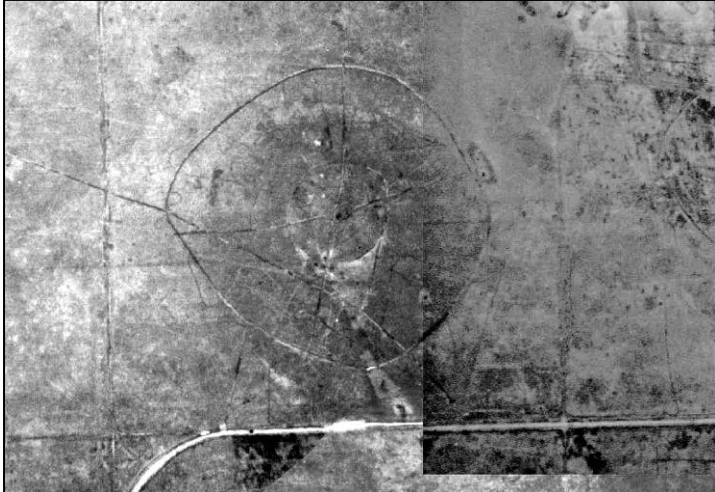
Table 5-2. Range Examples – Bombing and Gunnery (Concluded)

Description	Range Diagram or Photo
<p>Site: Conway Bombing and Gunnery Range, SC</p>	
<p>Range Name: Range III</p>	
<p>Range Type(s): Bombing, Practice; Bombing, Live Air-to-Ground Rocket</p>	
<p>Target Radius: 740 m (impact area) 1427 m (safety zone)</p>	
<p>Impact Area: 425 acres</p>	
<p>Safety Zone: 1580 acres</p>	
<p>Ordnance Types: Bomb, Incendiary; 4-lb and 6-lb; Bomb, 100-lb, Practice; Rocket, 5-in HVAR, Practice; Bomb, 20-lb Practice; Bomb, 250 lb GP, M57. (Old Style)</p>	
<p>Notes: Activities at range described as including practice bombing, incendiary and general purpose (live) bombing, demolition bombing, (land) skip bombing, dive bombing, high and medium altitude bombing, and air-to-ground rocketry.</p>	
<p>Site: Conway Bombing and Gunnery Range, SC</p>	
<p>Range Name: Range XX</p>	
<p>Range Type(s): Air-to-Ground Rocket Air-to-Ground Gunnery</p>	
<p>Range Length: 1890 m (impact area)</p>	
<p>Impact Area: 80 acres</p>	
<p>Safety Zone: 1,290 acres</p>	
<p>Ordnance Types: (None found in 2002 EECA. Potential munitions include Rocket, 2.25 , SCAR; Rocket, 3.5"; Projectile, 20 mm)</p>	
<p>Notes: Activities at range described as air-to-ground rocket, strafing, skip bombing, and position firing course, air-to-ground gunnery.</p>	

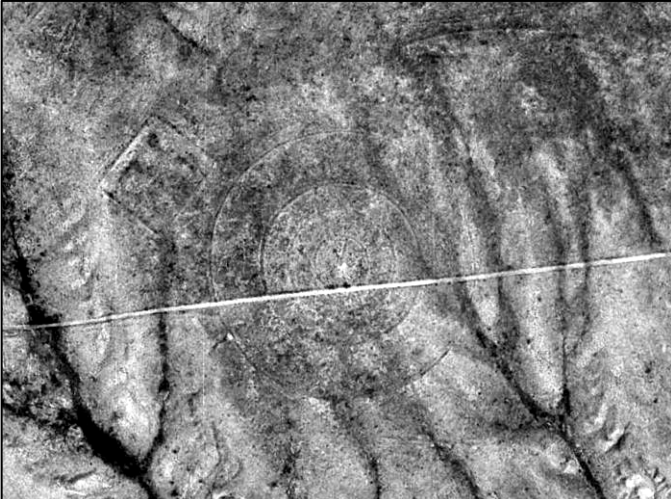
5.2 Factors Controlling MEC Distribution

Several factors affect targeting accuracy, penetration, and MEC distribution. From studies completed in World War II, 99 percent of the bombs should be found within 900 meters (3,000 feet) of the bull-eye for bombers flying at 7,600 meters (25,000 feet) or below at speeds up to 400 kph (250 mph). The same study implied a 600-meter (2,000-foot) radius should include 95 percent of the bombs under the same conditions (Source: USACE–St. Louis, 2002).

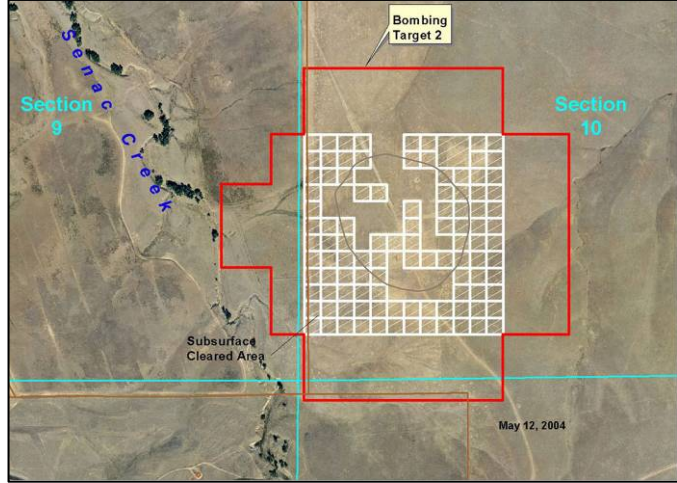
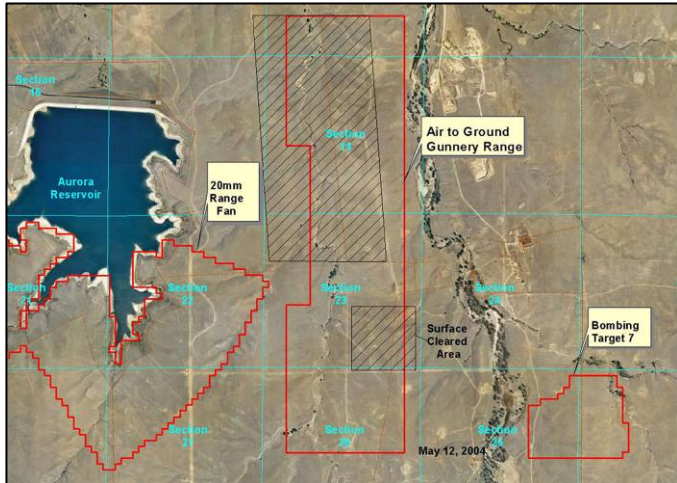
Penetration depth is largely controlled by the size and shape of the bomb and by the orientation at the time of impact. Penetration depth can be calculated using several different methods. Theoretical ordnance penetration depths, as reported in EM 1110-1-4009, are shown for several types of bombs in Table 5-3.

Table 5-3. Theoretical Penetration Depths for Air-Delivered Ordnance

Ordnance Item	Depth of Penetration in meters/feet			
	Limestone	Sand	Soil Containing Vegetation	Clay
M38A2, 100 lb		2.62/8.6	3.45/11.3	4.63/15.2
AN-M41A1 20 lb practice		1.52/5.0	2.0/6.6	3.28/10.0
25 lb frag		0.64/2.1	0.85/2.8	1.31/4.3

NOTE: All bombs are assumed to have impact velocity of 350 m/sec (1,135 ft/sec)

5.3 MEC Distribution

The theoretical MEC distribution from air-delivered weapons depends on several factors, including the type of weapons used, the altitude, the wind patterns, and the orientation of the bombing and gunnery runs. Assuming that bombing runs have a single preferred run-in-line, one might expect an MEC pattern that is slightly elliptical along the run-in-line of attack. However, if the target approach is from several different directions, the resulting MEC distribution is likely to be much more circular in appearance; this is generally the pattern observed in aerial photographs and in geophysical surveys of these ranges. Figure 5-3 shows the common pattern of MEC anomaly distribution in and around circular bombing targets. The pattern is general distributed around the center, but an axis of anomalies is also evident running northwest to southeast.

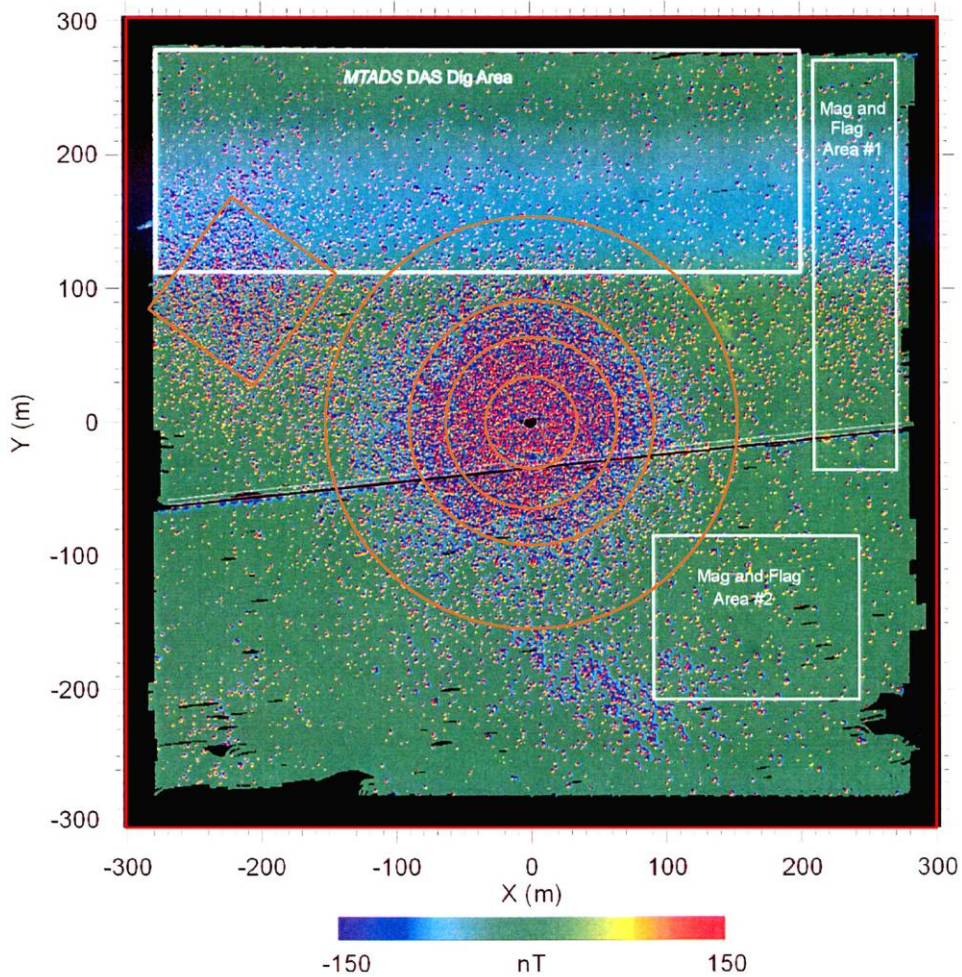

Source: Modified from McDonald, et al., 1998. Added overlay of target rings.

Figure 5-3. Example of Bombing Range MEC Anomaly Distribution, MTADS Survey of Pueblo of Laguna Target N-10

Example site case studies of selected bombing and gunnery ranges including range layouts and summaries of MEC and clutter items found in munitions investigation or removal actions are presented in Appendix C.

SECTION 6 - REFERENCES

6.1 Reference Documents

- Blackhawk UXO Services, 2003. Geophysical Prove Out, Southshore Development Site, Former Lowry Bombing and Gunnery Range, Aurora, Colorado, Prepared For: Laing Village, LLC, July 10, 2003
- Butler, Dwain; Larsen, Robert J; Murphy, William M; and Simms, Janet E. U.S. Army Corps of Engineers Engineer Research and Development Center, ERDC/GSL TR-04-8, Guidelines for Planning Unexploded Ordnance (UXO) Detection Surveys, August 2004.
- Department of Defense Ammunition and Explosives Safety Standards 6055.9, DDESB Review (Vote) Copy, 1 December 2004.
- DOD, 2003. Joint Publication 1-02, DoD Dictionary of Military and Associated Terms, April 12, 2001 and online version, updated December 17, 2003 (<http://www.dtic.mil/doctrine/jel/doddict/>)
- DSB, 2003. Report of the Defense Science Board Task Force on Unexploded Ordnance. Defense Science Board, Washington, DC, December, 2003
- EPA Federal Facilities Restoration and Reuse Office, 2000. Institutional Controls and Transfer of Real Property Under CERCLA Section 120(h)(3)(A), (B), or (C), Interim Final Guidance, January 2000. U.S. Environmental Protection Agency, Washington, DC.
- EPA, Handbook on Response Actions Involving Munitions and Explosives of Concern (MEC) and Munitions Constituents (MC), Review Draft. U.S. Environmental Protection Agency, Washington, DC
- EPA, 2002. Handbook on the Management of Ordnance and Explosives at Closed, Transferring, and Transferred Ranges and Other Sites, Interim Final. U.S. Environmental Protection Agency, Washington, DC, February 2002
- EPA, 2005. Terms of the Environment, (<http://www.epa.gov/OCEPATERMS/>)
- ESTCP, 2001. Cost and Performance Report, Electromagnetic and Magnetic Sensor Fusion for Enhanced UXO Target Classification. UX-9812, Environmental Security Technology Certification Program, March, 2001.
- Federal Advisory Committee for the Development of Innovative Technologies, Unexploded Ordnance (UXO): An Overview, Naval Explosive Ordnance Disposal Technology Division, UXO Countermeasures Department, October 1996.
- Foster Wheeler Environmental Corporation and Environmental Chemical Corporation, 2001. Final Remedial Investigation / Feasibility Study Report for OUB1 Sites, Former Naval Air Facility, Adak Island, Alaska. Prepared for Commanding Officer, Engineering Field Activity, Northwest Naval Facilities Engineering Command, Poulsbo, Washington, July 2001
- Foster Wheeler Environmental Corporation and Environmental Chemical Corporation, 2002. Draft Final After-Action Report - 2001 Field Season, Former Naval Air Facility, Adak Island, Alaska. Prepared for Commander, Engineering Field Activity Northwest Naval Facilities Engineering Command, Poulsbo, Washington, March 2002
- Foster Wheeler Environmental Corporation, 2003. Final After-Action Report for 2002 Field Season for OU B-1 Sites, Former Naval Air Facility, Adak Island, Alaska. MAY 2003

- Foster Wheeler Environmental, 2000. Draft Final Preliminary Assessment Report, Selected Areas of Concern in Operable Unit B, Former Naval Air Facility, Adak, Alaska. RAC I/Delivery Order No. 0083, Foster Wheeler Environmental Corporation, Anchorage, AK. December 01, 2000
- Foster Wheeler Environmental, 2000. Draft Site Investigation Report, Selected Areas of Potential Concern in Operable Unit B, Former Naval Air Facility, Adak, Alaska. Navy RACI/Delivery Order No. 0083, February 7, 2000
- IT Corporation, 1999. Ordnance and Explosives Engineering Evaluation/Cost Analysis (EE/CA), Fort Ritchie Army Garrison, Washington County, Maryland. Prepared for the U.S. Army Corps of Engineers, Baltimore District, September 2000.
- MACTEC, 2004. Comprehensive Basewide Range Assessment Report, Former Fort Ord, California, Draft Revision C, July 30, 2004
- McDonald, J. R., H.H. Nelson, and R. Robertson, 1999. MTADS Live Site Survey, Bombing Target #2 at the Former Buckley Field, Arapahoe County, CO. NRL/PU/6110-99-379, Naval Research Laboratory, Washington, DC
- McDonald, J.R., H. David Wright, Nagi Khadr, and H. H. Nelson, 2001. Airborne MTADS Demonstration on the Impact Area of the Badlands Bombing Range, NRL/PU/6110--02-453, Naval Research Laboratory, Washington, DC, September 2001
- McDonald, J.R., H.H. Nelson, R. Robertson, and R. Jeffries, 1998, MTADS Live Site Demonstration, Pueblo of Laguna, NM, NRL/PU/6110-00-398, Naval Research Laboratory, Washington, DC
- MGC, 2000. Former Lowry Training Annex, Air Force EOD Range, Area C–Buffer Zone. Slide presentation, MicroGeophysics Corporation Wheat Ridge, CO, January 2000 (<http://www.flbgr.org/pdfs/2000/FLTA/AirForce-2000-01-19.pdf>)
- Military Munitions Rule: Hazardous Waste Identification and Management; Explosives Emergencies; Manifest Exception for Transport of Hazardous Waste on Right-of-Ways on Contiguous Properties, Final Rule, 40 C.F.R. ' 260 et seq.
- National Oil and Hazardous Substances Pollution Contingency Plan (more commonly called the National Contingency Plan), 40 C.F.R. ' 300 et seq.
- NAVEODTECHDIV, 1999. ORDATA II, Enhanced International Deminer's Guide to UXO Identification, Recovery, and Disposal, Naval Explosive Ordnance Disposal Technology Division, Indian Head, MD, January 1999 (<http://www.maic.jmu.edu/ordata>).
- Nelson, H.H., D.A. Steinhurst, David Wright, Tom Furuya, J.R. McDonald, Bruce Barrow, Nagi Khadr, and Jonathan Haliscak, 2003. MTADS Magnetometer Survey of the Badlands Bombing Range, SD Impact Area, Combined Airborne, Vehicular, and Man-portable Survey, September 2002. NRL/MR-MM/6110--03-8666, Naval Research Laboratory, Washington, DC, February 14, 2003
- OSD, 2003. Department of Defense Memorandum, Definitions Related to Munitions Response Actions, from the Office of the Under Secretary of Defense, December 18, 2003.
- Parsons, 2002. Final Engineering Evaluation and Cost Analysis Work Plan for the Badlands Bombing Range, Phase IV. Prepared for U.S. Army Engineering Support Center, Huntsville, Alabama and U.S. Army Corps of Engineers, Omaha District, Nebraska, April 2002

- Parsons, 2003. Draft Final OE-15DRO.1–2 After-Action Report, Geophysical Investigation of Eastern Boundary, Excavation of Range 26 Berm and Clearance of Machine Gun Links from 12-Grid Area. Prepared for U.S. Army Corps of Engineers, Sacramento District, July 2003
- Parsons, 2003. Final Engineering Evaluation and Cost Analysis Report for the Badlands Bombing Range, Volume I, Revision 1. Prepared for U.S. Army Engineering Support Center, Huntsville, Alabama and U.S. Army Corps of Engineers, Omaha District, Nebraska, May 2003
- Parsons, 2003. Final Engineering Evaluation and Cost Analysis Report for the Former Badlands Bombing Range, Volume II. Prepared for U.S. Army Engineering Support Center, Huntsville, Alabama and U.S. Army Corps of Engineers, Omaha District, Nebraska, May 2003
- Parsons, 2003. Final Engineering Evaluation and Cost Analysis Report for the Former Badlands Bombing Range, Volume III. Prepared for U.S. Army Engineering Support Center, Huntsville, Alabama and U.S. Army Corps of Engineers, Omaha District, Nebraska, May 2003
- Parsons, 2003. Final Engineering Evaluation and Cost Analysis Report for the Former Conway Bombing and Gunnery Range, Conway, South Carolina. Prepared for U.S. Army Engineering Support Center, Huntsville, Alabama, September 2003
- Parsons, 2003. Final Time Critical Removal Action Report, Conway Bombing and Gunnery Range, Conway, South Carolina. Prepared for U.S. Army Engineering Support Center, Huntsville, Alabama, February 2003
- Selstrom, Col. John. Supporting the DoD Operational Range Sustainment Program and Building the Military Munitions Response Program, presentation at the 29th Environmental and Energy Symposium & Exhibition held April 9 2003 in Richmond, Virginia
- SERDP/ESTCP and ITRC, 2006. Survey of Munitions Response Technologies, Strategic Environmental Research and Development Program, June 2006.
- Shaw Environmental, 2003. Fort Ritchie Army Garrison Non-Time-Critical OE Removal Action, Ordnance and Explosives Removal Action Report, Final Document. Prepared for U.S. Army Corps of Engineers, Baltimore District, Maryland, April 2003
- U.S. Army, 1965. Training Manual TM 5-855-1, Fundamentals of Protective Design (Non-Nuclear), July 1965.
- U.S. Army, 2001. Action Memorandum, Time-Critical Removal Action (Surface Removal), Ordnance and Explosives Site, Ranges 43–48, Former Fort Ord, Monterey County, California. October 23, 2001
- U.S. Navy, 2001. Final Record of Decision, OU B-1, U.S. Navy, Naval Facilities Engineering Command (NAVFAC), Engineering Field Activity, Northwest, Poulsbo, WA, October 31, 2001
- USA Environmental, 2001. Final After-Action Report, Geophysical Sampling, Investigation, and Removal, Former Fort Ord, California, Site Del Rey Oaks Group, Volume 1 of 15. Prepared for U.S. Army Corps of Engineers, Sacramento District, California, April 2001.
- USA Environmental, 2003. Final Project Report, Meandering Path Geophysical Mapping, Former Fort Ord, California. Prepared for U. S. Army Engineering Support Center, Huntsville, Alabama, October 2003.
- USACE, 2000a. U.S. Army Corps of Engineers Pamphlet No. 1110-1-18, Engineering and Design Ordnance and Explosives Response, April 24, 2000.
- USACE, 2000b. U.S. Army Corps of Engineers Engineering Manual 1110-1-4009, Engineering and Design Ordnance and Explosives Response, June 23, 2000.

- USACE, 2003. U.S. Army Corps of Engineers Engineering Manual, EM 1110-1-1200, Conceptual Site Models for Ordnance and Explosives and Hazardous, Toxic and Radioactive Waste Projects, February 3, 2003.
- USACE, 2004. U.S. Army Corps of Engineers ERDC/TR-04-8, Guidelines for Planning Unexploded Ordnance (UXO) Detection Surveys August, 2004.
- USACE-New England, 2003. Munitions Survey Project, Phase I, Final Report, Massachusetts Military Reservation, Camp Edwards, Massachusetts. U. S. Army Corps of Engineers, New England District, Prepared for National Guard Bureau, Arlington, Virginia, May 2003
- USACE-Omaha, 2003. Badlands Bombing Range Newsletter, U.S. Army Corps of Engineers, Omaha District, November 2003.
- USACE-Rock Island, 1995a. Archive Search Report Findings for the Conway Bombing and Gunnery Range, Horry County, South Carolina. U.S. Army Corps of Engineers, Rock Island District, September 1995
- USACE-Rock Island, 1995b. Archive Search Report Findings for the Former Tobyhanna Artillery Range, Tobyhanna, Pennsylvania. U.S. Army Corps of Engineers, Rock Island District, September 1995
- USACE-Rock Island, 2000. Archive Search Report Findings for the Pine Ridge Gunnery Range. U.S. Army Corps of Engineers, Rock Island District, May 2000.
- USACE-St. Louis, 1995. Archives Search Report Findings for Buckley Field, Arapahoe County, Colorado. U.S. Corps of Engineers, St. Louis District, May 1995
- USACE-St. Louis, 1996. Final Archives Search Report, Conclusions and Recommendations, Fort Ritchie, Washington County, MD. U.S. Army Corps of Engineers, St Louis District, December 1996.
- USACE-St. Louis, 1998. Archives Search Report Findings for the Kirtland PBR No. N-10, Bernalillo County, New Mexico. U.S. Corps of Engineers, St. Louis District, April 1998
- USACE-St. Louis, 2002. Army Range Inventory Data Collector Instructions, Defense Environmental Restoration Program for Formerly Used Defense Sites Ordnance and Explosives. U.S. Army Corps of Engineers, St. Louis District, April 2002
- USACE-TEC, 1999. Badlands Bombing Range, GIS-Based Time-Sequence Analysis. USACE, Engineer Research and Development Center, Topographic Engineering Center, Alexandria, VA, September 1999.
- USDA-FSA-APFO, 2005. National Agricultural Inventory Project (NAIP), Aerial Orthophoto - Shannon County, SD, USDA, Farm Service Agency, Aerial Photography Field Office, Salt Lake City, UT
- Weston, 2004. Engineering Evaluation/Cost Analysis Work Plan, Former Tobyhanna Artillery Ranges, Tobyhanna, Pennsylvania. Prepared for Pennsylvania Department of Environmental Protection, and U.S. Army Corps of Engineers, Baltimore District, April 12, 2004
- Weston, 2004. Final Work Plan, Expanded Scope Time Critical Removal Action (TCRA) for Emergency Vehicle Access Roads, Pennsylvania State Game Lands #127, Tobyhanna, Pennsylvania. Prepared for U.S. Army Corps of Engineers, Baltimore District, April 2004

6.2 Additional Technical and Guidance References and Websites

UXO Program Managers should have the following reference materials within arm's reach:

Butler, Dwain, Larsen, Robert J, Murphy, William M, Simms, Janet E., U.S. Army Corps of Engineers Engineer Research and Development Center, ERDC/GSL TR-04-8, Guidelines for Planning Unexploded Ordnance (UXO) Detection Surveys. August 2004.

Cecchine, Gary, et al, Transferring Army BRAC Lands Containing Unexploded Ordnance, Lessons Learned and Future Options, Rand Arroyo Center, ISBN 0-8330-3636-X. 2004.

Cecchine, Gary, et al, Unexploded Ordnance, A Critical Review of Risk Assessment Methods, Rand Arroyo Center, ISBN 0-83330-3432-4. 2004.

Department of Defense Ammunition and Explosives Safety Standards 6055.9, Chapter 12, Real Property Known or Suspected to Contain Munitions and Explosives of Concern and/or Chemical Agent, DDESB Review (Vote) Copy 1. December 2004.

Department of Defense Ammunition and Explosives Safety Standards 6055.9, Chapter 15, UXO, DDESB Review (Vote) Copy. 1 December 2004.

[Environmental Security Technology Certification Program \(ESTCP\) Website,](http://www.estcp.org/)
[\(http://www.estcp.org/\)](http://www.estcp.org/)

Headquarters, Department of the Army, DA Pamphlet 385-63, Range Safety, Washington, DC. 10 April 2003.

Headquarters, Department of the Army, Training Circular No. 25-1, Training Land, Washington, DC. 15 March 2004.

Headquarters, Departments of the Army and the Marine Corps, Army Regulation 385-63, Range Safety, Washington, DC. 19 May 2003.

Interstate Technology Regulatory Council, Technical/Regulatory Guideline, Geophysical Prove-Outs for Munitions Response Projects. November 2004.

Interstate Technology Regulatory Council, Technical/Regulatory Guideline, Munitions Response Historical Records Review. November 2003.

Office of the Under Secretary of Defense For Acquisition, Technology, and Logistics, Report of the Defense Science Board Task Force on Unexploded Ordnance, Washington D.C., December 2003.

[Strategic Environmental Research and Development Program \(SERDP\) Website,](http://www.serdp.org/)
[\(http://www.serdp.org\)](http://www.serdp.org/)

U.S. Army Aberdeen Test Center, Standardized UXO Technology Demonstration Sites Handbook, Report No. TC -8539, Aberdeen Proving Ground, MD. October 2002.

[USAEC Standardized UXO Technology Demonstration Site Program Website,](http://www.uxotestsites.org/)
[\(http://www.uxotestsites.org\).](http://www.uxotestsites.org/)

- U.S. Army Corps of Engineers Engineer Pamphlet 385-1-95a, Basic Safety Concepts and Considerations for Ordnance and Explosives Operations. 29 June 2001.
- U.S. Army Corps of Engineers Engineering Manual 1110-1-4009, Engineering and Design Ordnance and Explosives Response. June 23, 2000.
- U.S. Army Corps of Engineers Engineering Manual EM 1110-1-1200, Conceptual Site Models for Ordnance and Explosives and Hazardous, Toxic and Radioactive Waste Projects. February 3, 2003.
- U.S. Army Corps of Engineers Pamphlet 1110-1-18, Engineering and Design Ordnance and Explosives Response. April 3, 2006.
- U.S. Army Corps of Engineers, Engineering Pamphlet 75-1-2, Unexploded Ordnance (UXO) Support During Hazardous, Toxic, and Radioactive Waste (HTRW) and Construction Activities, Washington, DC. 20 November 2000.
- U.S. Army Corps of Engineers, St. Louis District, Army Range Inventory Data Collector Instructions, Defense Environmental Restoration Program for Formerly Used Defense Sites Ordnance and Explosives, Appendix F, Range Information/Description/Cells. April 2002.
- U.S. Army Training Manual TM 5-855-1, Fundamentals of Protective Design (Non-Nuclear), Chapter 6, Penetration, July 1965.

ACRONYMS

ADEC	Alaska Department of Environmental Conservation
AJCC	Alternate Joint Communication Center
AOPC	Area of potential concern
AP	Armor-piercing
APT	Armor-piercing tank
ARAR	Applicable or relevant and appropriate requirement
ASR	Archive Search Report
ATSDR	Agency for Toxic Substances and Disease Registry
BRAC	Base Realignment and Closure
CEP	Circular error probability
CERCLA	Comprehensive Environmental Response, Compensation, and Liability Act
CSM	Conceptual site model
DDESB	Department of Defense Explosives Safety Board
DERP	Defense Environmental Restoration Program
DGM	Digital geophysical mapping
DGPS	Differential global positioning system
DMM	Discarded military munitions
DoD	Department of Defense
DQO	Data quality objective
EE/CA	Engineering Evaluation/Cost Analysis
EM	Engineer Manual
EOD	Explosive ordnance disposal
EPA	Environmental Protection Agency
ESTCP	Environmental Security Technology Certification Program
FUDS	Formerly Used Defense Sites
HE	High-explosive
JUXOCO	Joint UXO Coordination Office
M&F/M&D	Mag and flag/Mag and Dig
MAAWS	Multi Role Anti Armor Anti Personnel Weapon System
MC	MEC Clutter
MCE	Maximum credible event
MEC	Munitions and explosives of concern
MI	Munition Item
MITC	Military Intelligence Training Center
MM	Military munitions

MR	Munitions response
MRA	Munitions response area
MRS	Munitions response site
MILS	Short for milliradian.
MSL	Mean sea level
MTADS	Multi-sensor Towed Array Detection System
NAF	Naval Air Facility
NCP	National Contingency Plan
NEW	Net explosive weight
NMC	Non-MEC clutter
NPL	National Priorities List
NRL	Naval Research Laboratory
NSGA	Naval Security Group Activity
OE	Ordnance and explosives
PA/SI	Preliminary assessment/site inspection
PIRS	Project Information and Retrieval System
PRG	Preliminary remediation goal
QA/QC	Quality assurance/quality control
Q-D	Quantity-distance
RAAWS	Ranger Anti Armor/Assault Weapon System
RCRA	Resource Conservation and Recovery Act
RI/FS	Remedial investigation/feasibility study
ROD	Record of Decision
ROE	Right-of-entry
SARA	Superfund Amendments and Reauthorization Act
SDZ	Surface danger zone
SERDP	Strategic Environmental Research and Development Program
SI	Site Investigation
TAC	The Aleut Corporation
TDEM	Time-domain electromagnetic
USACE	U.S. Army Corps of Engineers
USAEC	U.S. Army Environmental Center
USFWS	U.S. Fish and Wildlife Service
UXO	Unexploded ordnance
WhP or WP	White phosphorus

GLOSSARY

11X Rule: A geophysical rule of thumb developed empirically by the U S Army Corps of Engineers describing the maximum depth to which a metallic munition or munition-like (elongated ellipsoidal) object can be detected by a geophysical survey. The maximum detection depth is 11 times the minor axis diameter of the object. Modern, multi-sensor techniques may be able to surpass this rule of thumb.

Clutter: Munitions-related scrap and other common metallic field debris that can mask signals of interest or generate signals not of interest, thereby affecting sensor performance.

Defense Site: Location that is or was owned by, leased to, or otherwise possessed or used by the DoD. The term does not include any operational range, operating storage or manufacturing facility, or facility that is used for or was permitted for the treatment or disposal of MEC. The term includes formerly used defense sites (FUDS) (10 U.S.C. 2710[e][1]).

Discarded Military Munitions (DMM): Military munitions that have been abandoned without proper disposal or removed from storage in a military magazine or other storage area for the purpose of disposal. The term does not include unexploded ordnance, military munitions that are being held for future use or planned disposal, or military munitions that have been properly disposed of, consistent with applicable environmental laws and regulations (10 U.S.C. 2710[e][2]).

Military Munitions (MM): All ammunition products and components produced for or used by the armed forces for national defense and security, including ammunition products or components under the control of the DoD, the Coast Guard, the Department of Energy, and the National Guard. The term includes confined gaseous, liquid, and solid propellants, explosives, pyrotechnics, chemical and riot control agents, smokes, and incendiaries, including bulk explosives and chemical warfare agents, chemical munitions, rockets, guided and ballistic missiles, bombs, warheads, mortar rounds, artillery ammunition, small arms ammunition, grenades, mines, torpedoes, depth charges, cluster munitions and dispensers, demolition charges, and devices and components thereof. The term does not include wholly inert items, improvised explosive devices, and nuclear weapons, nuclear devices, and nuclear components, except that the term does include non-nuclear components of nuclear devices that are managed under the nuclear weapons program of the Department of Energy after all required sanitization operations under the Atomic Energy Act of 1954 (42 U.S.C. 2011 et seq.) have been completed (10 U.S.C. 101[e][4]). Military munitions are also defined by federal regulation see 40 CFR 260.10.

MILS: A military unit for defining angles. The name derives from milliradian, and they are used because an angle of X mils is X meters wide at a distance of one kilometer. This means that if you drop a shell 200 meters to one side of the target (according to your map) and it is 4 km away, 200 divided by 4 is 50, so you swing your aim by 50 mils. Although there are 6283.1853 mils in a circle, the US military “standardized” the number to 6400 mils. There are 17.8 mils is a degree.

Munitions Constituents: Any materials originating from unexploded ordnance, discarded MEC, or other MEC, including explosive and non-explosive materials, and emission, degradation, or breakdown elements of such ordnance or munitions (10 U.S.C. 2710 [e][4]).

Munitions and Explosives of Concern (MEC): A relatively new term that in 2003 replaced ordnance and explosives (OE) as the new “umbrella term.” It includes those military munitions that pose an explosive safety risk and consists of three types of military munitions: UXO (fired

military munitions, see 10 U.S.C. 2710 [e][9]), DMM (military munitions abandoned without proper disposal, see 10 U.S.C. 2710 [e][2]), and MC (munitions constituents present in sufficient concentration to constitute an explosive hazard (e.g., TNT greater than 10 percent in soil).

Munitions Debris (MEC Scrap or MEC Clutter): A military munition or component thereof that does not contain explosives or pyrotechnics. Examples include practice munitions without spotting charges, inert training munitions, expended ejection munitions, and fragments of exploded/destroyed MEC that do not contain explosives or pyrotechnics.

Munition Item: Term equivalent to Munitions and Explosives of Concern (MEC).

Munitions Response: Response actions, including investigation, removal and remedial actions to address the explosives safety, human health, or environmental risks presented by MEC.

Munitions Response Area (MRA): Any area on a defense site that is known or suspected to contain unexploded ordnance, discarded MEC, or munitions constituents. Examples include former ranges or munitions burial areas. An MRA consists of one or more munitions response sites.

Munitions Response Site (MRS): A discrete location within a munitions response area that is known to require munitions response.

Net Explosive Weight (NEW) (DoD): The actual weight in pounds of explosive mixtures or compounds—including the trinitrotoluene equivalent of energetic material—that is used in determination of explosive limits and explosive quantity data arcs.

Non-MEC Clutter: Debris other than munitions debris (e.g., nails, wire, targets).

Ordnance: Weapons of all kinds including bombs, artillery projectiles, rockets and other munitions; military chemicals, bulk explosives, chemical warfare agents, pyrotechnics, explosive waste, boosters, and fuzes.

Preliminary Assessment (PA) and Site Inspection (SI). A preliminary evaluation of the existence of a release or the potential for a release. The PA is a limited-scope investigation based on existing information. The SI is a limited-scope field investigation. The decision that no further action is needed or that further investigation is needed is based on information gathered from one or both types of investigation. The results of the PA/SI are used by the DoD to determine if an area should be designated as a site under the Installation Restoration Program. EPA uses the information generated by a PA/SI to rank sites against Hazard Ranking System criteria and decide if the site should be proposed for listing on the National Priorities List (NPL).

Quantity-Distance (Q-D). The relationship between the quantity of explosive material and the distance separation between the explosive and people or structures. These relationships are based on levels of risk considered acceptable for protection from defined types of exposures. These are not absolute safe distances but are relative protective or safe distances.

Range: A facility on which weapons are fired to achieve military training objectives for live or inert fire. In a geographic sense, range means a designated land or water area that is set aside, managed, and used for DoD range activities. This term includes the following: (A) Firing lines and positions, maneuver areas, firing lanes, test pads, detonation pads, impact areas, electronic scoring sites, buffer zones with restricted access, and exclusionary areas. (B) Airspace areas designated for military use in accordance with regulations and procedures prescribed by the Administrator of the Federal Aviation Administration (10 U.S.C. 101[e][3]).

Render-Safe Procedures. The portion of explosive ordnance disposal (EOD) procedures involving the application of special EOD methods and tools to provide for the interruption of functions or separation of essential components of unexploded ordnance to prevent an unacceptable detonation.

Resource Conservation and Recovery Act (RCRA). The federal statute that governs the management of all hazardous waste from cradle to grave. RCRA covers requirements regarding identification, management, and cleanup of waste, including identification of when a waste is solid or hazardous; management of waste C transportation, storage, treatment, and disposal; and corrective action, including investigation and cleanup, of old solid waste management units.

Surface Danger Zone (SDZ): The ground and airspace designated within the training complex (to include associated safety areas) for vertical and lateral containment of projectiles, fragments, debris, and components resulting from the firing, launching, or detonation of weapon systems to include explosives and demolitions (Army Regulation, AR385-63).

Unexploded Ordnance (UXO): Includes three types of MEC (10 U.S.C.101 [e][5]):

- Primed, fused, armed, or otherwise prepared for action
- fired, dropped, launched, projected, or placed in such a manner that constitutes a hazard to operations, installations, personnel, or material
- Unexploded either by malfunction, design, or any other cause

Appendix A—Direct Fire Range Examples

SITES

- (FRD) Fort Ritchie, MD, 200-yd Range
- (FOD) Fort Ord, CA, Del Rey Oaks Area

Direct Fire Range: Fort Ritchie, MD, 200-yd Range

Range Overview

General Facility Description:

Fort Ritchie was established as Camp Ritchie in 1926 and used as a training area for the Maryland National Guard. Camp Ritchie was originally about 580 acres and rested partly on the slope of Quirauk Mountain and in the valley below. In World War II, the camp was leased by the U.S. Army for the war department's Military Intelligence Training Center (MITC) and expanded to 631 acres in 1940. Both the national guard and the MITC have used various ranges, especially targets on the side of Quirauk Mountain for mortar and artillery fire. In 1945, the MITC was deactivated and the Maryland National Guard re-instituted training. In 1948, the Army reacquired the site to support the Alternate Joint Communications Center (AJCC), the primary mission since the mid-1950s. The fort was officially closed in 1998 after being selected for closure in the 1995 BRAC round. The former fort has not been listed as a CERCLA site.

Location: Cascade, MD

Size: 631 acres

Range Types:

Artillery, machine gun, mortar and small arms (pistol, rifle) ranges

Typical Ordnance Types:

Bomb, 50lb (MKI-practice)	Mortar, 3" stokes (HE, practice)
Booby trap simulator	Mortar, 4.2" and 60mm (HE, practice)
Small Arms: .30, 45 and .50 caliber (AP, ball, tracer, and incendiary)	Mortar, 81mm, (HE, practice, WhP)
Fuze (grenade-rifle,rocket-2.36")	Mortar, German 50mm, Japanese Type 89
Hand and Rifle Grenades (incendiary, illumination, tear, and practice)	Rocket, 2.36"
Mine, anti-personnel (practice)	Shell, 37mm (practice, APT), 57mm (practice), 75mm, and 105mm (HE),
	Signals, illuminating

Geology/Soils:

Bedrock in the area is primarily older metamorphic rocks (quartzite, metabasalt and gneiss) with some sandstone. Soils are mainly upland soils formed from the underlying bedrock. Soil thickness varies from 0 to 1.2 meters (0-4 feet) on the side of Quirauk Mountain but can be up to 9 meters (30 feet) deep in the valley. Soils consist of clay with varying amounts of silt, sand and gravel. Metabasalt pebbles and clasts have a ferromagnetic signature and are found throughout the site.

Climate:

The mean annual temperature is 10°C to 13°C (50 to 55°F) and rainfall is 99 centimeters (39 inches) per year. Normal frost depth is 81 centimeters (32 inches). Snowfall is about 69 centimeters (27 inches) per year in nearby Hagerstown, Maryland.

Terrain:

The site is in the Blue Ridge physiographic province of the Appalachians Highlands division. The province consists of alternating mountain ridges and valleys. The site lies at the foot of Quirauk Mountain and extends into the valley below. Slopes are wooded, rocky, and steep (10% to 30%) and relief is about 130 meters (425 feet). Lake Royer (with an upper and lower dam) is located in the valley part of the facility. Wetlands surround the lake and its feeding stream.

Vegetation/Land Cover:

The slope of Quirauk Mountain is undeveloped and tree covered and is heavily wooded in places with significant underbrush. Wetlands are associated with Lake Royer and its feeding stream on the south and west side of the former base; these areas are also undeveloped. The remaining area of the base is fully developed with a wide variety of land uses typical to a military installation.

NOTE: The ordnance listed is for the entire facility, rather than the example range.

Direct Fire Range: Fort Ritchie, MD, 200-yd Range

Site-Specific References – Fort Ritchie

- IT Corporation, 1999. Ordnance and Explosives Engineering Evaluation/Cost Analysis (EE/CA), Fort Ritchie Army Garrison, Washington County, Maryland. Prepared for the U.S. Army Corps of Engineers, Baltimore District, September 2000.
- Shaw Environmental, 2003. Fort Ritchie Army Garrison Non-Time-Critical OE Removal Action, Ordnance and Explosives Removal Action Report, Final Document. Prepared for U.S. Army Corps of Engineers, Baltimore District, Maryland, April 2003
- USACE-St. Louis, 1996. Final Archives Search Report, Conclusions and Recommendations, Fort Ritchie, Washington County, MD. U.S. Army Corps of Engineers, St Louis District, December 1996.

Direct Fire Range: Fort Ritchie, MD, 200-yd Range

General Site Description

Fort Ritchie is located approximately one mile south of the Maryland/Pennsylvania border in Washington County, adjacent to the town of Cascade, Maryland (Figure FRD-1). It is situated near the upper end of a small valley at the foot of Quirauk Mountain, which is part of the South Mountain ridge. It was selected for closure in the 1995 BRAC round.

In preparation for BRAC transfer of the property, an Archive Search Report (ASR) was developed by the USACE soon after the installation was placed on the BRAC list. The entire installation was evaluated for the types and probable location of MEC. The ASR suggested a potential for UXO in certain areas in the west and southwest portions of former Fort Ritchie.

An EE/CA sampling investigation was initiated in 1997 to sample a representative portion of the areas indicated by the ASR as potentially containing UXO. The purpose of the EE/CA sampling investigation was to confirm the presence and determine the amount of UXO present in ASR areas. The area of potential concern was divided into six sectors and the EE/CA looked at five of the six sectors (Sectors 1, 3, 4, 5, and 6). Sector 2, was originally identified in the ASR as a potential UXO area but was removed from consideration in the ASR and the EE/CA due to a lack of evidence supporting UXO in this sector. The darker shaded area in Figure FRD-2 identifies the area of interest for MEC at Fort Ritchie.

Sector 3 is a 32.4 acre area that contains the recreational areas and Officer's Family Quarters. This sector was primarily a cantonment area with level terrain suitable for direct-fire ranges. Much of this sector was subsequently heavily developed into commercial and residential use in the post-range era (Figure FRD-2). The proposed land use for Sector 3 is about one-half commercial and one-half open space.

The ASR indicated that small arms were primarily used on portions of this sector on the National Guard pistol, rifle, and machine-gun ranges. Sector 3 includes the former National Guard 183 meter (200-yard) known distance range (small arms) and part of the combat fire range. Approximately 19 acres of the 32.4 acres were determined to be of interest; the remaining portion was either not within the range boundaries or was covered by structures and pavement. Empirical analysis of the ASR, EE/CA, and removal action information indicate that the 183 meter (200-yard) range in Sector 3 was used for training soldiers with rifle grenades and 2.36-inch rockets. The cleared area that empirically correlated with a rifle grenade range is analyzed in depth below.

The geophysical prove out (GPO) and UXO clearance operations for Sector 3 were chosen as an example because they have the best data available and are discussed below. The data and statistics presented pertain only to the area cleared in Sector 3 and cannot be extrapolated to the entire installation.

Direct Fire Range: Fort Ritchie, MD, 200-yd Range

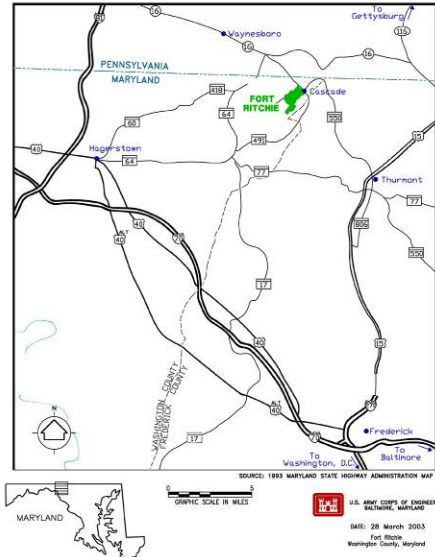

Source: Shaw Environmental, 2003

Figure FRD-1. Map of Fort Ritchie

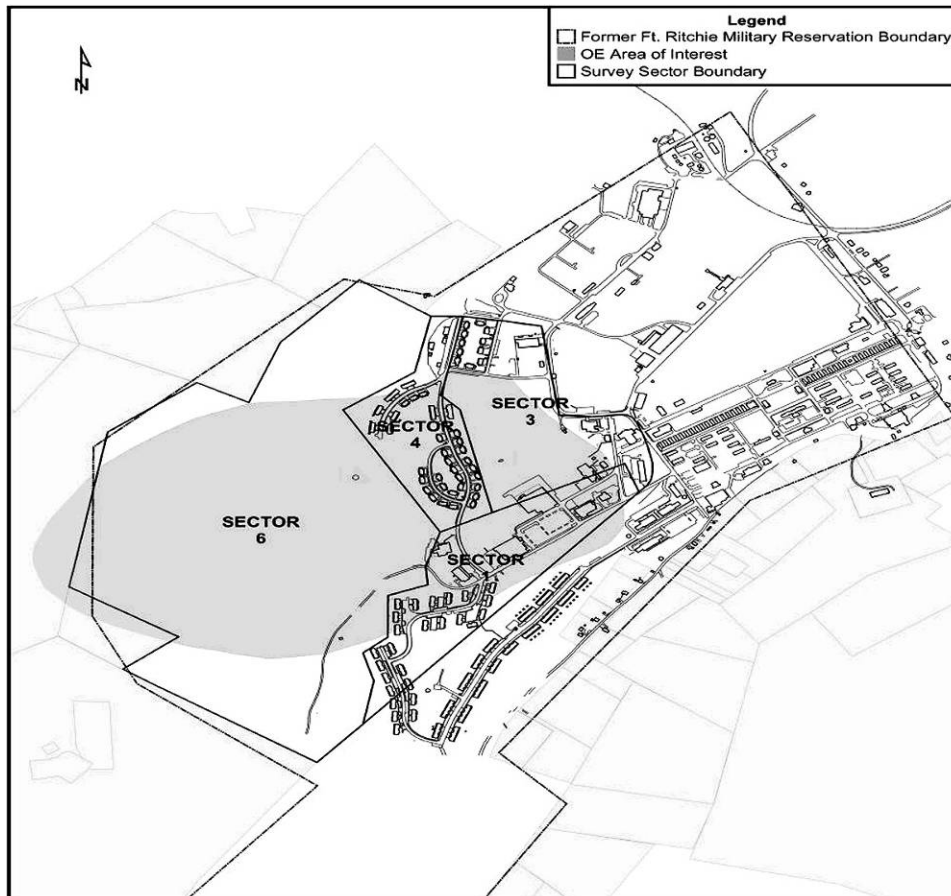

Figure FRD-2. Map of Fort Ritchie with Sector Locations

Direct Fire Range: Fort Ritchie, MD, 200-yd Range

Range Area Description

Sector 3 – 200-yd Range

During the removal action in Sector 3 all digital geophysical mapping (DGM) data were collected using a Geonics EM-61 instrument. Each grid was surveyed using search lanes spaced every 0.75 meters (2.5 feet) with 7.6 meter (25-foot) increments. Where terrain permitted, the instrument was operated in trailer mode and readings were automatically taken at approximately 20 centimeters (0.63-foot) intervals along each survey line as measured by an integrated survey wheel. For rough terrain where the trailer mode was impractical, the EM-61 was operated in the harness or backpack mode and readings were automatically collected at 0.2 second intervals or less. Due to the nature of the terrain and vegetation, DGM was not feasible for the actual clearance and traditional “mag and flag” UXO clearance procedures were employed using Schonstedt GA-72Cd fluxgate gradiometers and search lanes no wider than 1.5 meters (5 feet).

Four UXO were found in Sector 3 during the EE/CA sampling investigation—two high-explosive (HE)-filled 2.36-inch rockets, one 2.36-inch rocket fuze with booster (possibly associated with the 183 meter [200-yard] range), and one fuze 3-inch Stokes mortar training round with an HE spotting charge. All UXO items were found between 2 and 90 centimeters (1 and 36 inches) below ground surface. No UXO were found on the surface of Sector 3. In 1999, preparatory activities for the removal action began and actual UXO excavation and disposal occurred from June 2001 through October 2002. The survey and ordnance removal map of Sector 3 and adjacent sectors developed from data collected during the removal actions is shown in Figure FRD-3.

Table FRD-1. Fort Ritchie Sector 3, Direct Fire Range, Numerical Summary

Sector Area	Cleared Area		Number of Items Found				Mass Recovered (lbs)		
	Sq. Ft	Acres	MEC	MEC Clutter	Non-MEC Clutter	Totals	MEC & MC	Non-MEC	Total
3	812,995	18.7	26	101	4,069	4,196	382	7,186	7,568

MEC - munitions and explosives of concern
MC - MEC clutter

Table FRD-2. Fort Ritchie Sector 3, Direct Fire Range, Density Summary

Sector Area	Cleared Area		Average Item Density (#/acre)				Mass Density (lbs/acre)		
	Sq. Ft	Acres	MEC	MEC Clutter	Non-MEC Clutter	All Types	MEC	Non-MEC	Total
3	812,995	18.7	1.4	5.4	218	225	20	385	405

MEC - munitions and explosives of concern
MC - MEC clutter

Direct Fire Range: Fort Ritchie, MD, 200-yd Range

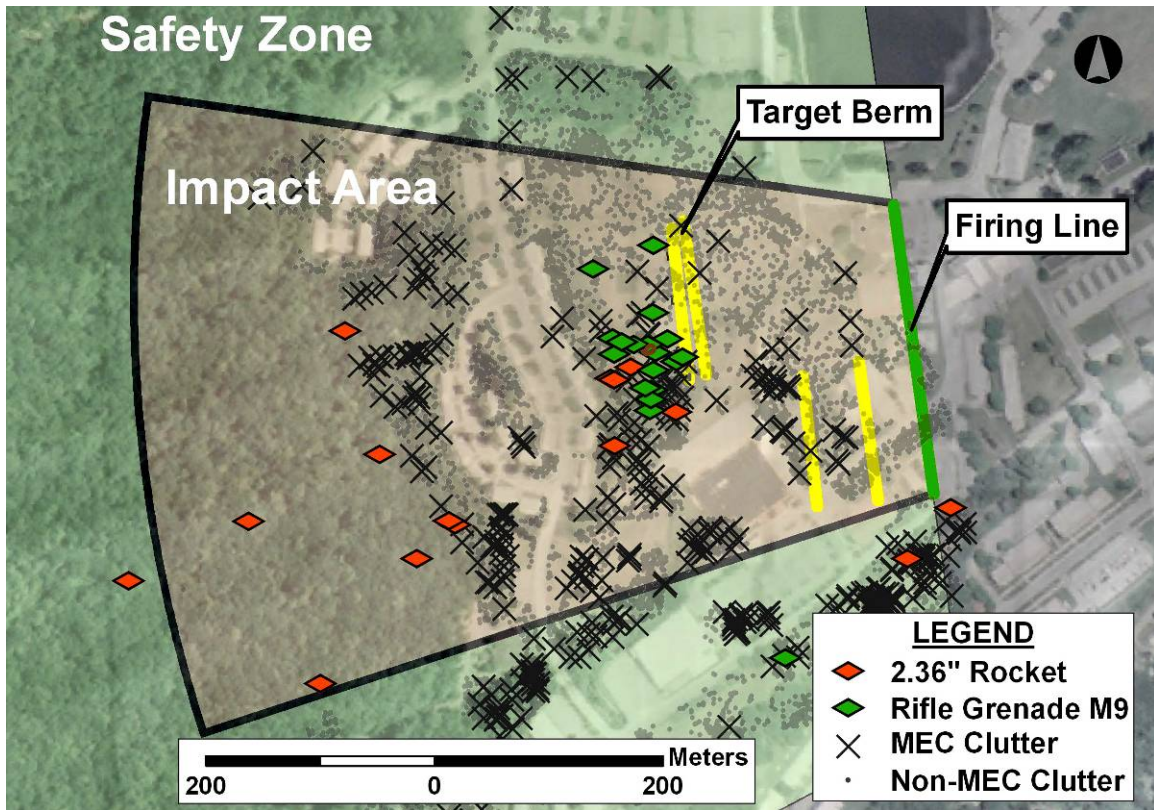

Figure FRD-3. Map of Fort Ritchie with Rocket and Rifle Grenade MEC Locations

Table FRD-3. Fort Ritchie Sector 3, Direct Fire Range, MEC Summary

Ordnance Type				Diameter (mm)	Sector 3		Total	
Category	Type	Purpose	Model		MEC	MC*		
Mortar	3-inch Stokes			76	4	53	57	
	60 mm	Training	M69	60		5	5	
	81 mm	Practice	M43 Series	81		1	1	
Projectile	37 mm			37		2	2	
	40 mm	Riot (Cs)	M674	37		1	1	
Rocket	2.36-inch			60		11	11	
		Heat	M6 Series	60	4		4	
		Motor		60		3	3	
		Practice	M7 Series	60		1	1	
Grenade	Hand Rifle	Incen	Th3, An-M14	64		1	1	
		(Unknown)				3	3	
		AT	M9 Series	57	17	6	23	
		AT, Practice	M11 Series	57		2	2	
Small Arms						7	7	
Fragment	(Unknown)					2	2	
Flare	(Unknown)					2	2	
Canister	Gas	Riot (Cs)				1	1	
Fuze	(Unknown)				1		1	
Grand Total								
						26	101	127

*MC= MEC Clutter

Direct Fire Range: Fort Ritchie, MD, 200-yd Range



Source: www.hq.usace.army.mil

Figure FRD-4. 2.36-inch Rocket Recovered from Fort Ritchie

Table FRD-4 summarizes the MEC recovery distribution by type during the removal action. Table FRD-5 provides the depth of UXO recovered and additional information on the ordnance. Table FRD-6 is a description of the MEC clutter, and Table FRD-7 provides some examples of the Non-MEC clutter found in Sector 3 during the removal action. Figure FRD-5 is a plot of the depth versus the diameter of the munition for all the MEC found at Fort Ritchie.

Table FRD-4. Fort Ritchie Sector 3 MEC Recovery Depth Distribution by Type

Category	Diameter (Mm)	Number Recovered	Depth Found (Inches)		
			Min	Max	Avg
Rifle Grenade, AT, M9 Series	57	17	2	48	15
Mortar, 3-inch Stokes	76	4	4	36	20
2.36 Inch, HEAT, M6 Series	60	4	6	30	14
Fuze, Unknown		1	12	12	12
Totals		26			

Direct Fire Range: Fort Ritchie, MD, 200-yd Range

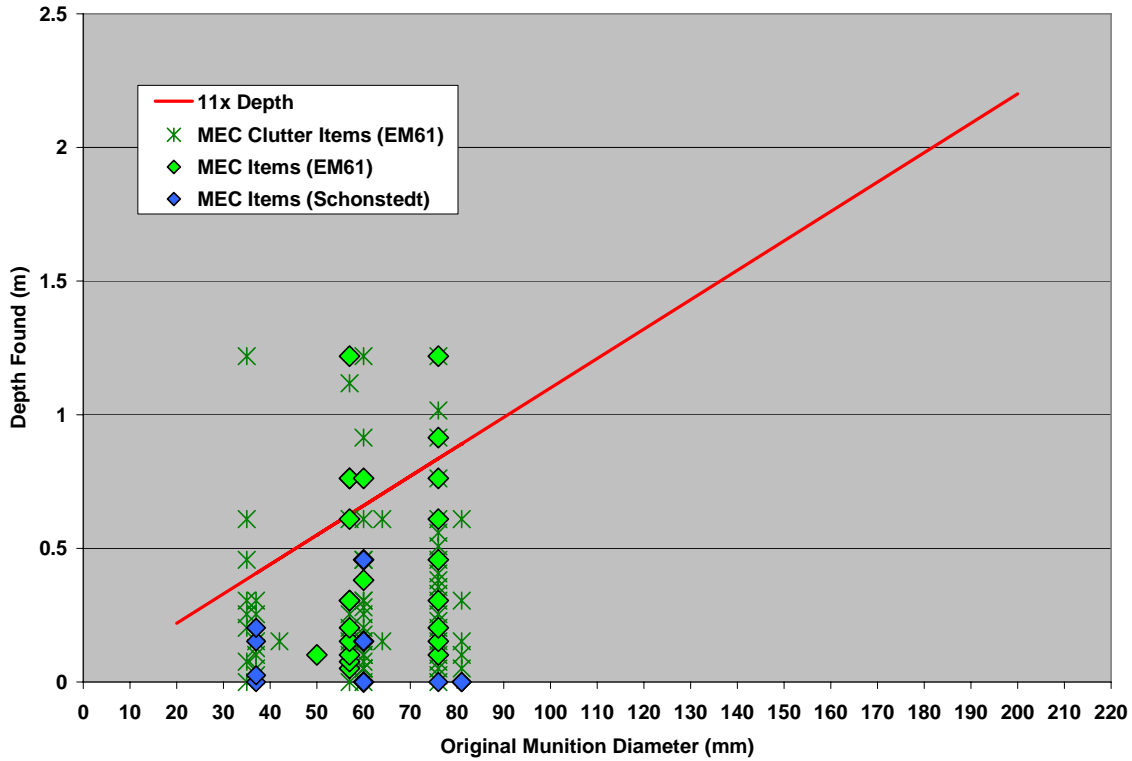

Figure FRD-5. Munition and Clutter Items, Diameter versus Depth at Fort Ritchie, All Range Areas

Table FRD-5. Fort Ritchie Sector 3 Recovery Depth of MEC

Ordnance Type	Depth (inches)	Filler Type	Spotting Charge	Practice Round	Fuze if Present
2.36" Rocket Fuze M6A1	6	HE	NO	NO	BD
2.36" Rocket Fuze M6A1	15	HE	NO	NO	BD
2.36" Rocket M6A1	6	HE	NO	NO	BD
2.36" Rocket M6A1	4	HE	NO	NO	BD
Four 3" Stokes Mortar MKI	6, 8, 30, 36	BP	YES	YES	AWA
12 Rifle Grenades M9	1 to 12	HE	NO	NO	BD
3 Rifle Grenade M9	24, 30, 48	HE	NO	NO	BD
Rifle Grenade M9 Fuze	30	HE	NO	NO	BD

Direct Fire Range: Fort Ritchie, MD, 200-yd Range

Table FRD-6. Fort Ritchie Sector 3 MEC Clutter

Description	Total Count
.30 bullet, plus 30 caliber case, bullet jacket	6
.30 cal cart case, plus 1 fan blade	2
.45 cal	4
.45 cal bullet , bolt, 6 " x 3/8 " dia	1
.45 cal. Bullets (2) , scrap 4 oz	1
2.36" ballistic weight	1
2.36" rocket (frag), rocket unfuzed , rocket motor (3), rocket motor, scrap	15
20mm, 1/2 oz, 20mm, base end	2
3" Stokes Mortar, 3" Stokes Mortar (3)	18
3" Stokes Mortar (unfuzed)	26
3" Stokes Mortar (unfuzed), scrap metal, utility	2
3" Stokes Mortar (unfuzed),concrete, did not remove	1
3" Stokes Mortar primer well, spent	1
3" Stokes Mortar sand filled	1
3" Stokes Mortar with 3046-003, and 3046-003A	2
3" Stokes Mortar, (inert), 3" Stokes Mortar, 4 oz.	1
37mm and scrap metal	3
60mm mortar (unfuzed) M69	1
60mm practice mortar (2), M69 (inert) (3) M69	3
60mm training mortar (unfuzed) (1), unfuzed M69	1
81mm practice mortar (inert)	1
Civilian 40mm tear gas projectile, and Civilian CS Canister (unfuzed)	2
5 flare body, nails, expended flare, flare body, scrap metal	4
Frag & M9 frag, M9 rifle grenade frag	9
Fragment of inert 2.35" AT Rocket, Practice	1
M11 practice rifle grenade (inert)	2
M14 Canister (unfuzed)	1
rifle grenade illumination, wire 4 "	1
tail boon for rifle grenade (inert), tin can lid, 15" tent peg	3

Table FRD-7. Fort Ritchie Sector 3 Representative Examples of Non-MEC Clutter

Description	
1/2" pipe, 2' long	Door hinge, drill bit, aerosol can
1/4" bolt 2" long	electric line, 2' and 3' deep
1/4" bolts, 38 count	electric utility – scrap metal
1/4" hook	electrical cables, connectors, plugs
10 gal milk jug	fence posts 6"– 14", fence end cap
10" chain, 12" rebar	Hammer, 16 oz Hammer head
12" steel rod	hex Nut, hinge, tin cup
18" head of pick	"hot rock", horse shoe
2 lbs angle iron	influence from power line or sewer
2" tin can, 2" wire	lump of slag
auto parts, sheet metal, AAA battery	monitoring well, did not remove

Direct Fire Range: Fort Ritchie, MD, 200-yd Range

Direct Fire Range: Fort Ord, CA, Del Rey Oaks Ranges

Direct Fire Range: Fort Ord, CA, Del Rey Oaks Ranges

Range Overview

General Facility Description:

Fort Ord was founded in 1917 and served primarily as training and staging facility for infantry troops. From 1947 to 1975, Fort Ord was a basic training center. After 1975, the 7th Infantry Division (Light) occupied Fort Ord. Light infantry troops operated without heavy tanks, armor, or artillery. Fort Ord was selected in 1991 for decommissioning, but troop reassignment was not completed until 1994 when the post formally closed. Although Army personnel still operate parts of the base, no active Army division is stationed at Fort Ord. Ordnance clearance is expected to take up to 20 years and cost \$380 million.

Location: Seaside, Ca

Size: 28,000 acres

Range Types:

There area over 200 ranges covering about 8,000 acres of the former post. Direct fire ranges comprise about 430 acres and consist of machine gun, mortar and small arms (pistol, rifle) ranges

Typical Ordnance Types:

Bomb, 50lb (MKI-practice)

Booby trap simulator

Small arms: .30 and 50 caliber plus 5.56 and 7.62 mm

Rifle grenades, M9, M11, M17, and M29

Grenade, hand (fragmentation, illumination, practice, tear, and incendiary)

Mine, anti-personnel (practice)

Mortar, 3" stokes (HE, practice)

Mortar, 4.2" and 60mm (HE, practice)

Mortar, 81mm, (HE, practice, WhP)

Rocket, 2.36" and 3.5" plus 35mm

Shell, 105mm (HE), 37mm (practice, APT)

Shell, 20mm, 22mm, 57mm (practice) and 75mm, 76mm, and 90mm

Signals, illuminating

Geology/Soils:

Fort Ord is at the transition between the mountains of the Santa Lucia Range and the Sierra de la Salinas to the south and southeast, respectively, and the lowlands of the Salinas River Valley to the north. The geology of Fort Ord generally reflects this transitional condition with older, consolidated rock is exposed near the southern base boundary that becomes buried under a northward-thickening sequence of poorly consolidated deposits to the north. The predominant soil is highly permeable sand that forms dunes and limits runoff.

Climate:

Warm, dry summers and cool, rainy winters typify the post. Precipitation averages 36 centimeters (14 inches) per year. The Pacific Ocean moderates the climate causing morning fog and onshore winds throughout the year. Daily air temperatures typically range from 40° to 70°F, but temperatures in the low 100s have occurred.

Terrain:

Elevations drop from about 270 meters (900 feet) mean sea level (msl) at Impossible Ridge along the eastern edge of the former base to the ocean on the western side of the former base. The topography reflects the existing active and historically stabilized sand dunes. Closed drainages within dunes are common.

Vegetation/Land Cover:

Central maritime chaparral is the most extensive natural community at Fort Ord and covers about 12,500 acres in the south-central portion of the post. Oak woodlands are widespread and occupy about 5,000 acres. Grasslands, primarily in the southeastern and northern portions of the post, cover about 4,500 acres. There are five other community types but they cover less than 500 acres each. The remaining 4,000 acres are developed and do not support ecological communities.

Note: The ordnance listed is a compilation from 4 of the 200 ranges at the former Fort Ord and not for example range.

Direct Fire Range: Fort Ord, CA, Del Rey Oaks Ranges

Site-Specific References – Fort Ord

- MACTEC, 2004. Comprehensive Basewide Range Assessment Report, Former Fort Ord, California, Draft Revision C, July 30, 2004
- Parsons, 2003. Draft Final OE-15DRO.1–2 After-Action Report, Geophysical Investigation of Eastern Boundary, Excavation of Range 26 Berm and Clearance of Machine Gun Links from 12-Grid Area. Prepared for U.S. Army Corps of Engineers, Sacramento District, July 2003
- US Army, 2001. Action Memorandum, Time-Critical Removal Action (Surface Removal), Ordnance and Explosives Site, Ranges 43–48, Former Fort Ord, Monterey County, California. October 23, 2001
- USA Environmental, 2001. Final After-Action Report, Geophysical Sampling, Investigation, and Removal, Former Fort Ord, California, Site Del Rey Oaks Group, Volume 1 of 15. Prepared for U.S. Army Corps of Engineers, Sacramento District, California, April 2001.
- USA Environmental, 2003. Final Project Report, Meandering Path Geophysical Mapping, Former Fort Ord, California. Prepared for U. S. Army Engineering Support Center, Huntsville, Alabama, October 2003.

Direct Fire Range: Fort Ord, CA, Del Rey Oaks Ranges

General Site Description

Fort Ord is located on the California coast along the shores of Monterey Bay (Figure FOD-1). Before the Army's use of the property, the area was agricultural, as is much of the surrounding land today. No permanent improvements were made until the late 1930s, when administrative buildings, barracks, mess halls, tent pads, and a sewage treatment plant were constructed. In 1938, additional agricultural property was purchased for the development of the Main Garrison. At the same time, the beachfront property was donated to the Army. The Main Garrison was constructed between 1940 and the 1960s, starting in the northwest corner of the base and expanding southward and eastward. Over its history, the post was home to a succession of infantry divisions and served as a center for basic and advanced training. In 1975, the post became the home to the 7th Infantry Division, which conducted training exercises on the installation.

Fort Ord was identified by the U.S. Environmental Protection Agency (EPA) as a federal Superfund site on the basis of groundwater contamination discovered on the base in 1990. Fort Ord was selected for closure in 1991 and placed on the BRAC list. The 7th Infantry Division (Light) was inactivated in September 1993, and the soldiers were reassigned elsewhere. The post officially closed on September 30, 1994.

In 1993 an archival investigation was conducted to locate areas where MEC may have been used. Additional archive searches, follow-on interviews and visual inspections conducted since 1993 indicate that approximately 12,000 acres are known or suspected to contain MEC. Twenty-nine MR sites were identified in the Phase 1 EE/CA. A Phase 2 EE/CA established a process to evaluate the remaining sites. The MRAs range from less than one acre to more than 1,000 acres, although most are less than 200 acres. To date approximately 3,000 acres have been investigated and/or received response actions designed to minimize the explosive safety risk to the public. The removal process used at Fort Ord is documented in the EE/CAs which were prepared in accordance with CERCLA.

An Impact Area is located in the south-central portion of Fort Ord and is designated as a MR site. Lands within the boundaries of the Impact Area are expected to have the highest density of MEC, with specific target areas having the highest densities. Types of MEC found at Fort Ord include artillery projectiles, rockets, hand grenades, land mines, pyrotechnics, bombs, demolition materials and other items. Known MR sites are posted with warning signs and are off-limits to unauthorized people.

Over 200 range areas have been identified on the Former Fort Ord, and it employed a very large impact area used by many ranges including the Del Rey Oaks ranges (Figure FOD-2). The direct-fire ranges cleared—analyzed in depth below—comprised only about 430 acres of a total installation of almost 28,000 acres. The data and statistics presented in this report pertain only to the range areas as specified and cannot be extrapolated to the entire installation.

The Del Rey Oaks (DRO) Group reuse parcel consists of Ranges 24, 25, 26, and 43. The DRO group is located approximately four miles east of the city of Monterey and is adjacent to the city of Del Rey Oaks, in Monterey County, California. The DRO Group is located within the southwesterly boundary of the former Fort Ord Army installation. The four ranges are situated

Direct Fire Range: Fort Ord, CA, Del Rey Oaks Ranges

along the outer westerly boundary of the Multi-Range Area (Impact Area). This area is known to contain high densities of MEC from the over 60 years of use as the installation's inner range.

Portions of the westerly boundaries of the DRO Group abut residential and light commercial property on the westerly side. The fences along the outer boundary of the former installation prohibit public access on the DRO Group.

The Del Rey Oaks Range complex was used for a variety of crew-served direct-fire weapon system normally found in light infantry units. Based on historic evidence of light infantry ranges cleared elsewhere, ranges like DRO were used by large numbers of soldiers in both basic and unit training. Clearances of similar ranges elsewhere have uncovered a number of MEC burial pits where individuals and units have disposed of used ammunition by burying it at depths from near surface to more than 1.5 meters (5 feet) deep. Many soldiers training at Del Rey Oaks would have been equipped with full combat loads of live and training ammunition even if the munitions may not have been fired on this range. Small arms, unused hand and smoke grenades, simulators, and other pyrotechnics were most probably carried during direct-fire weapons training by crew members. Numerous machine-gun links will be encountered (links are left when machine guns are fired, are not hazardous, are not accountable, and are not reusable).

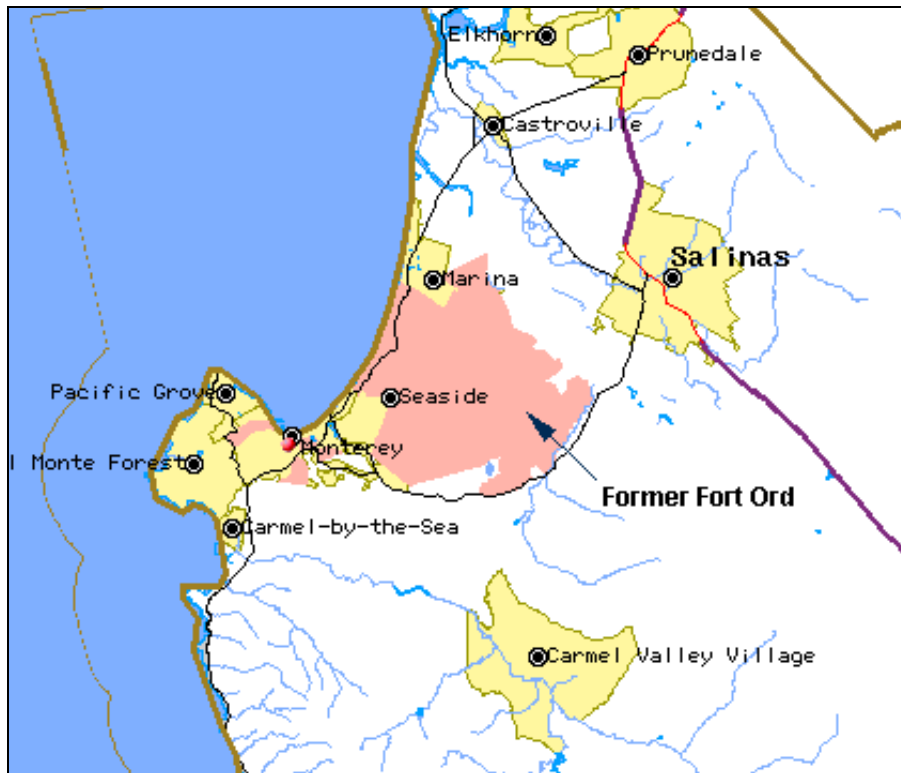

Figure FOD-1. Location Map for Fort Ord, South of San Francisco, California

Direct Fire Range: Fort Ord, CA, Del Rey Oaks Ranges

Range Area Description

Del Rey Oaks Area (Ranges 24, 25, 26, 43)

The Del Rey Oaks reuse parcel consists of Ranges 24, 25, 26, and 43 (Figure FOD-3). At the time of base closure, Range 24 was a small-arms range (sniper range). Based on past records and field investigations, this range appears to have also been used for antitank 35mm subcaliber training. In addition, 37-mm and 40-mm projectiles have also been found within this former range. Historical maps and photos from 1965 indicate that Range 24 has been referred to as Range 21 and the general area was used for automatic-rifle training (Army, 2000). Range 25 was a small-arms range at the time of closure and was referred to as an offensive overhead firing range.

Range 25 was a small-arms range at the time of closure and was referred to as an offensive overhead firing range. Records indicate that Range 26 was a machine-gun transition range at the time of base closure. Training with 3.5-inch rockets, 37-mm projectiles, and mortars also occurred on this range. Records and recent field investigations indicate that Range 26 was used for 2.36-inch rocket training. A 1945 facilities map labeled identified this range as “Austin Anti-Tank,” which is consistent with the rockets use in this area. Historical maps and photos show that Range 26 was used for machine-gun training (U.S. Army, 2000).

According to an ASR, a portion of the ridge at Site OF-43 (South Boundary Areas) was used as a backstop for rifle grenades and shoulder-launched projectiles from 1942 to 1944. Firing pits located along South Boundary Road were buried when their use was discontinued. More recently, UXO personnel supporting brush-cutting activities reported finding fragments of a 37mm low-explosive projectile, MK II, at the northwest end of Site OE-43 (U.S. Army, 2000). Table FOD-1 is the numerical summary of Del Rey Oaks, which includes total area and number of items found.

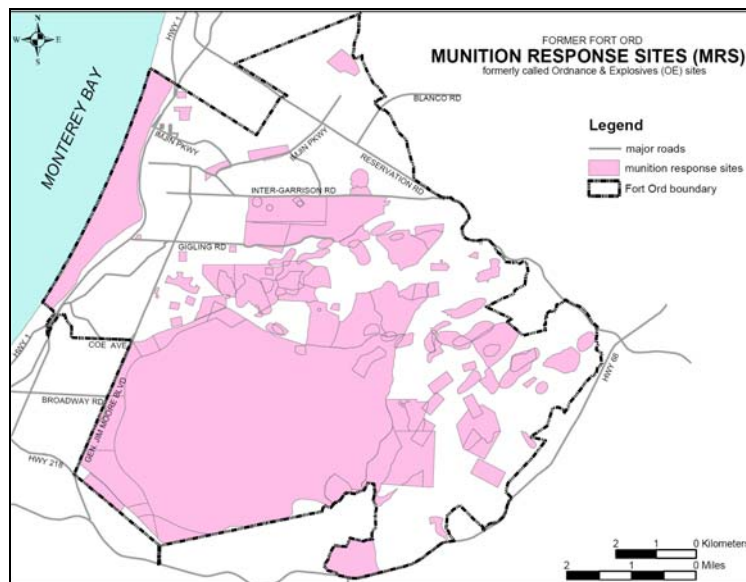

Source: www.fortordcleanup.com

Figure FOD-2. Munitions Response Areas at the former Fort Ord

Direct Fire Range: Fort Ord, CA, Del Rey Oaks Ranges

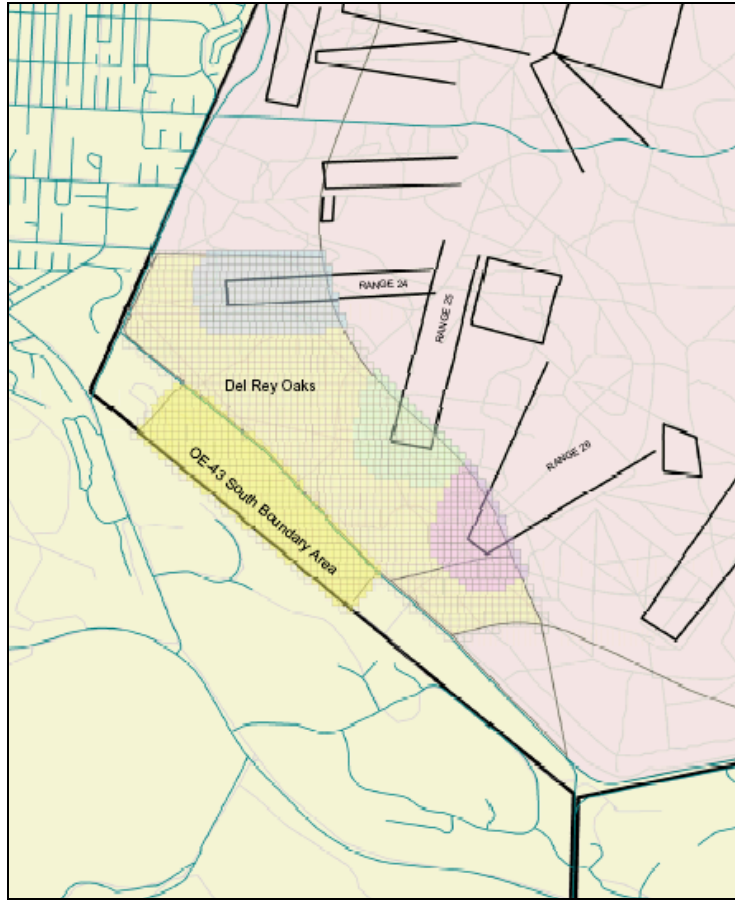

Figure FOD-3. Del Rey Oaks Site Map with Range SDZ's Depicted

Table FOD-1. Del Rey Oaks Numerical Summary

Range Areas	Area		Number of Items Found				Totals	Clearance Depth
	Sq. Ft	Acres	MEC	MC	Non-MC	NF/ND		
Range 24 - Sniper Range	2,360,000	54.2	73	833	113	3	1022	4'
Range 25 - Offensive Overhead Firing Course	1,630,000	37.4	7	141	53	26	227	4'
Range 26 - Machine Gun Field	1,630,000	37.4	33	1227	2034	133	3427	4'
South Boundary Area (Of 43)	3,980,000	91.4	13	147			160	4'
Remaining DRO Areas	9,140,000	209.8	19	206	24	9	258	4'
TOTAL	18,740,000	430.2	145	2554	2224	171	5094	

Direct Fire Range: Fort Ord, CA, Del Rey Oaks Ranges

MEC Dispersion

Direct-fire weapons are designed for flat trajectory with the impacts observable from the firing point. Since direct-fire weapons are used primarily against point targets (such as vehicles and bunkers), MEC should be distributed most heavily near the known target locations along the center line between the firing points and targets. Figure FOD-4 shows MEC distribution for the Del Rey Oaks parcels based on geophysical surveys using electromagnetics (EM61) and magnetometers. Although the range fans extend well into the other parcels, clearance activities, driven by property transfer, were primarily conducted in the Del Rey Oaks area. Table FOD-2 is the Grid Density Summary. Table FOD-3 identifies anomaly depth distribution by type. Table FOD-4 is the MEC distribution by type while Table FOD-5 is the recovery depths for UXO items. Figure FOD-5 shows a plot of recovery depths versus munition diameter for both MEC and MEC clutter items. The MEC clutter items are plot according to their original intact diameter.

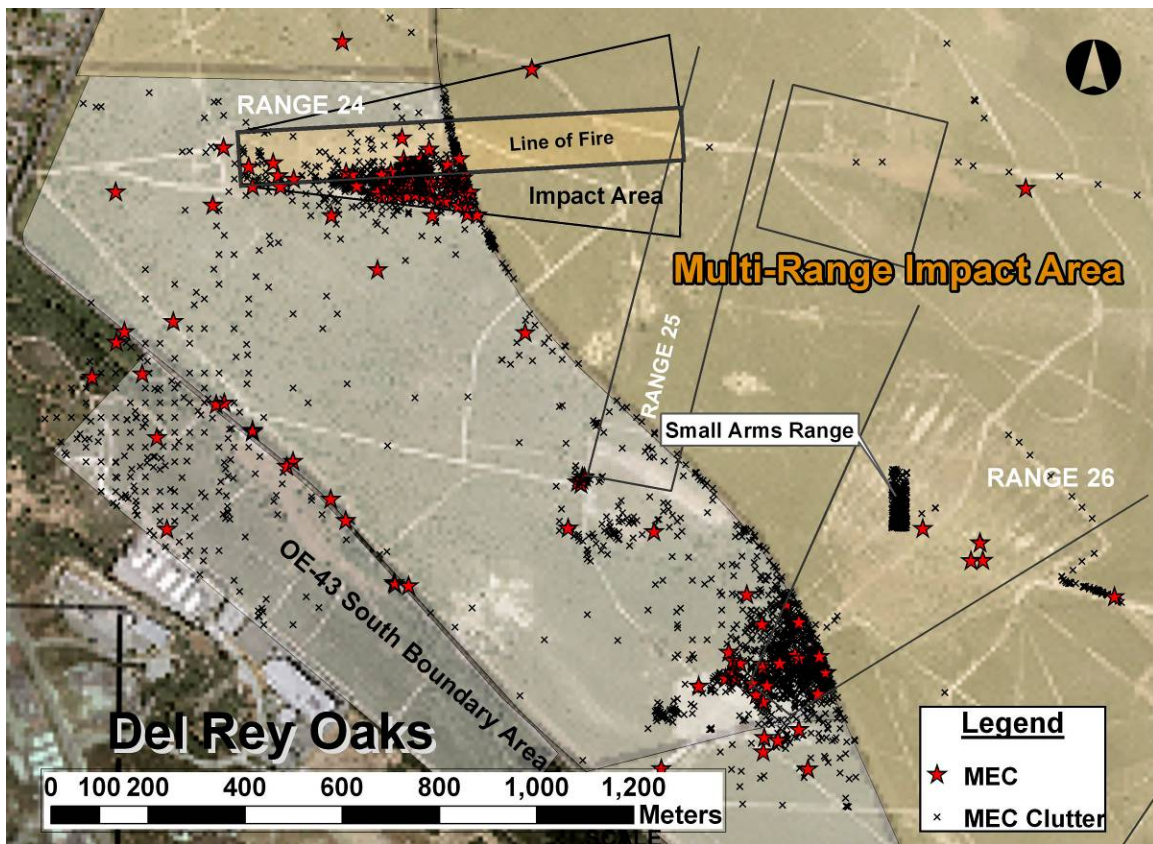

Figure FOD-4. Del Rey Oaks MEC Distribution

Direct Fire Range: Fort Ord, CA, Del Rey Oaks Ranges

Table FOD-2. Del Rey Grid Density Summary

Range Area	Total Number of Grids	Grids Without Anomalies	Measure	Item Type			
				MEC	MEC Clutter	Non-MEC Clutter	NF/ND
Range 24 - Sniper Range	236	124	Number of Grids Found	31	113	12	3
		53%	Percent of Total Grids	13%	48%	5%	1%
			Maximum (#/acre)	30	270	139	4
			Average (#/acre)	10	33	41	4
Range 25 - Offensive Overhead Firing Course	163	95	Number of Grids Found	4	59	15	12
		58%	Percent of Total Grids	2%	36%	9%	7%
			Maximum (#/acre)	13	39	83	26
			Average (#/acre)	8	10	15	9
Range 26 - Machine Gun Field	163	32	Number of Grids Found	24	126	66	36
		20%	Percent of Total Grids	15%	77%	40%	22%
			Maximum (#/acre)	17	366	558	44
			Average (#/acre)	6	45	134	16
South Boundary Area (OF 43)	398	287	Number of Grids Found	7	109		
		72%	Percent of Total Grids	2%	27%		
			Maximum (#/acre)	17	22		
			Average (#/acre)	8	6		
Remaining DRO Areas	914	802	Number of Grids Found	12	107	8	8
		88%	Percent of Total Grids	1%	12%	1%	1%
			Maximum (#/acre)	35	126	48	9
			Average (#/acre)	7	8	13	5
Combined Areas	1874	1340	Number of Grids Found	78	514	101	59
		72%	Percent of Total Grids	4%	27%	5%	3%
			Maximum (#/acre)	35	366	558	44
			Average (#/acre)	8	22	96	13

Table FOD-3. Del Rey Oaks Anomaly Depth Distribution by Type and Percent

Depth (Inches)	MEC	MEC Clutter	Non-MEC Clutter	No Find	All Types	MEC	MEC Clutter	Non-MEC Clutter	No Find	All Types
Surface	34	679	239		952	23%	27%	11%		19%
>0 - 6	89	1546	1017		2652	61%	61%	46%		52%
>6 - 12	13	164	167		344	9%	6%	8%		7%
>12 - 24	8	36	56		100	6%	1%	3%		2%
>24 - 36		5	5		10		0.2%	0.2%		0.2%
>36 - 48	1	2	1		4	1%	0.1%	0.0%		0.1%
>48										
Unknown		122	739	171	1032		5%	33%	100%	20%
Totals	145	2554	2224	171	5094	100%	100%	100%	100%	100%

Direct Fire Range: Fort Ord, CA, Del Rey Oaks Ranges

Table FOD-4. Del Rey Oaks MEC Distribution by Type

MEC Type	Range 24		Range 25		Range 26		South Boundary Area		Remaining DRO Areas		Combined Areas		Totals
	MEC	MC	MEC	MC	MEC	MC	MEC	MC	MEC	MC	MEC	MC	
Unknown		7		2		99						108	108
CARTRIDGE CASE, (UNKNOWN)						2						2	2
CARTRIDGE CASE, 40 MM						2						2	2
CARTRIDGE CASE, 57 MM				4								4	4
CARTRIDGE, 40 MM		147							1		1	147	148
CARTRIDGE, IGNITION									1		1		1
DEMOLITION MATERIAL, CHARGE, 0.25-LB									1		1		1
FLARE, (UNKNOWN)				2		5						7	7
FLARE, SURFACE		1				1		1		1		4	4
FRAGMENT, (UNKNOWN)		21		19		172		17		30		259	259
FUZE, HAND GRENADE		5	7	48	2	61	1	3		2	10	119	129
FUZE, MINE		22				1						23	23
FUZE, PROJECTILE		1				3				2		6	6
FUZE, TRENCH MORTAR		1										1	1
HAND GRENADE, (UNKNOWN)						3						3	3
HAND GRENADE, FRAG							3				3		3
HAND GRENADE, ILLUM					2	8	1				3	8	11
HAND GRENADE, PRACTICE		1		13		3		1		6		24	24
HAND GRENADE, RIOT									1		1		1
HAND GRENADE, SMOKE		4		3	2	2	2	4	1	8	5	21	26
IGNITER, TIME FUSE										1		1	1
MORTAR, 3 INCH		1								1		2	2
MORTAR, 4 INCH STOKES	1	2									1	2	3
MORTAR, 4.2 INCH		1										1	1
MORTAR, 60 MM						7						7	7
MORTAR, 81 MM						2						2	2
PROJECTILE, 20 MM						1						1	1
PROJECTILE, 22 MM SUBCAL		2		1								3	3
PROJECTILE, 37 MM		13			4	46	2	101	4	61	10	221	231
PROJECTILE, 40 MM	1	11			1	6					2	17	19
PROJECTILE, 57 MM										1		1	1
PROJECTILE, 75 MM		2		4		5				5		16	16
PROJECTILE, 76 MM						1						1	1
PROJECTILE, 90 MM		1										1	1
PYROTECHNIC MIXTURE, ILLUM	1				5						6		6
PYROTECHNIC MIXTURE, SMOKE						1						1	1
RIFLE GRENADE, (UNKNOWN)						2						2	2
RIFLE GRENADE, M11, AT, PRACTICE						10		18		4		32	32
RIFLE GRENADE, M17, FRAG						3						3	3
RIFLE GRENADE, M29, AT, PRACTICE										1		1	1
RIFLE GRENADE, M9, AT							1				1		1
RIFLE GRENADE, SMOKE						163	1	1			1	164	165
ROCKET, (UNKNOWN)						1						1	1
ROCKET, 2.36 INCH					5	128		1	3	8	8	137	145
ROCKET, 3.5 INCH				10		58				30		98	98
ROCKET, 35 MM	70	393		2	1	1			6		77	396	473
SIGNAL, ILLUM		17		11	11	309				7	11	344	355
SIGNAL, SMOKE						1						1	1
SIMULATOR, PROJECTILE		3		1								4	4
SMALL ARMS, .30 CAL		18		9		29				2		58	58
SMALL ARMS, .50 CAL						34						34	34
SMALL ARMS, 5.56 MM				2		5						7	7
SMALL ARMS, 7.62 MM		5		1		20				9		35	35
SMALL ARMS, MISC		153		10		32				27		222	222
SMOKE POT, 10-LB							2		1		3		3
Grand Total	73	832	7	142	33	1227	13	147	19	206	145	2554	2699

Direct Fire Range: Fort Ord, CA, Del Rey Oaks Ranges

Table FOD-5. Recovery Depth of UXO Items (All Areas Combined)

Category	Type	Purpose	Model Series	Diameter (mm)	Number Recovered	Depth Found (in)		
						Min	Max	Avg
CARTRIDGE	40 MM	PRACTICE	M781	40	1	0	0	0
CARTRIDGE	IGNITION		M2 SERIES		1	2	2	2
DEMOLITION MATERIAL	CHARGE, 0.25-LB	DEMOLITION	TNT		1	3	3	3
FUZE	HAND GRENADE	IGNITING	M201		1	6	6	6
FUZE	HAND GRENADE	PRAC	M205 SERIES		3	1	1	1
FUZE	HAND GRENADE	PRAC	M228		6	1	48	13
HAND GRENADE	FRAG	FRAG	MK II	57	3	24	24	24
HAND GRENADE	ILLUM	ILLUM	MK I	53	3	1	8	4
HAND GRENADE	RIOT	RIOT	CN1, ABC-M25A1	75	1	3	3	3
HAND GRENADE	SMOKE	SMOKE	AN-M8, HC	62	1	2	2	2
HAND GRENADE	SMOKE	SMOKE	M18 SERIES	64	4	4	6	5
MORTAR	4 INCH STOKES	SMOKE	WP (STOKES)	101.6	1	4	4	4
PROJECTILE	37 MM	HE	MK II	37	1	8	8	8
PROJECTILE	37 MM	LE	MK I	37	9	0	12	5
PROJECTILE	40 MM	ILLUM / PARACHUTE	M583 SERIES	40	2	0	0	0
PYROTECHNIC MIXTURE	ILLUM				6	0	24	5
RIFLE GRENADE	M9, AT	AT	M9 SERIES	57	1	24	24	24
RIFLE GRENADE	SMOKE	SMOKE	M23 SERIES	46	1	6	6	6
ROCKET	2.36 INCH	HEAT	M6	60	7	0	18	8
ROCKET	2.36 INCH	MOTOR		60	1	0	0	0
ROCKET	35 MM	SUBCAL/PRACTICE	M73	35	77	0	12	2
SIGNAL	ILLUM	GROUND	M125 SERIES	42	1	3	3	3
SIGNAL	ILLUM	GROUND	M126 SERIES	42	1	8	8	8
SIGNAL	ILLUM	GROUND	M131		1	10	10	10
SIGNAL	ILLUM	GROUND, PARACHUTE, RIFLE	M17 SERIES (M17A1)	41	8	0	12	5
SMOKE POT	10-LB	SCREENING	M1, HC	140	3	0	6	4

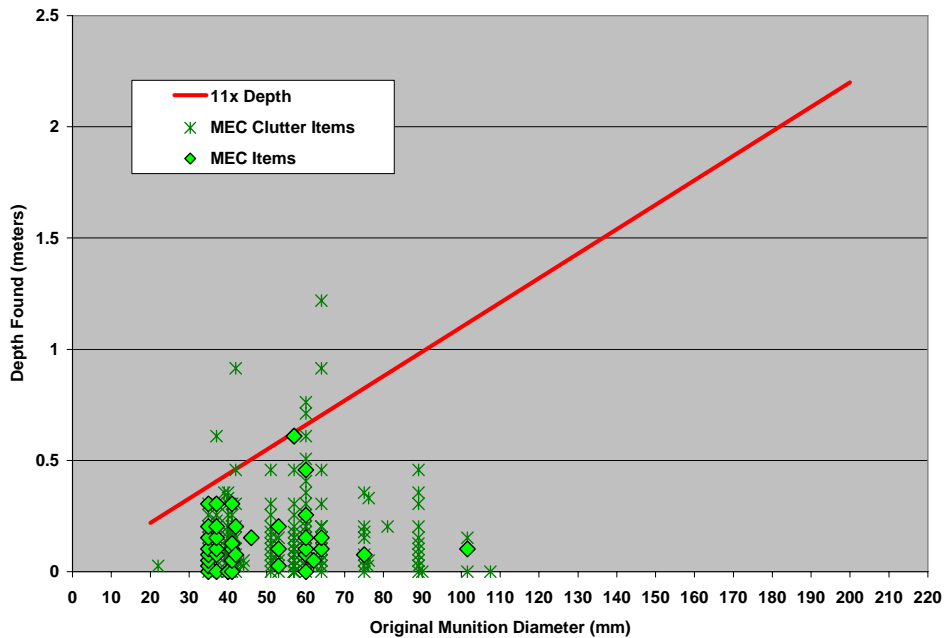

Figure FOD-5. MEC and Clutter Items, Diameter versus Depth at Fort Ord, Del Rey Oaks Range

Appendix B—Indirect Fire Range Examples

SITES

(ADI) Adak Naval Air Facility, AK, Mitt Lake Mortar Range

(FRI) Fort Ritchie, MD, Combat Range/Quirauk Mountain

Indirect-Fire Range,: Adak, AK, Mitt Lake Mortar Range Impact Area

Range Overview

General Facility Description: Because of its strategic location, Adak was selected by the military as a base of operations to counteract the Japanese invasion of World War II. In 1959, Public Land Order 1949 designated the northern portion of Adak (76,800 acres) for use by the Navy for military purposes. The Naval Complex has two areas with extensive development: the downtown area of Adak, where NAF Adak was located and the second area, which includes the northern part of the Island and areas around Clam Lagoon. There are over 131 ranges on the facility and 104 have been declared as “no further action” sites. Adak was closed on March 31, 1997. The U.S. Fish and Wildlife Service manages the southern portion (117,265 acres) of the island, which is a designated wilderness area within the Alaska Maritime National Wildlife Refuge system. The facility was added to the NPL in 1994.

Location: Adak Island, AK (Aleutian Islands)

Size: Ranges cover about 20,000 acres of the 76,800 acre facility.

Range Types: Training involved coastal artillery batteries, anti-aircraft guns, and small arms using a variety of munitions including rockets, mortars, and small caliber ammunition.

Typical Ordnance Types:	Mortar, 3” stokes (HE, practice)
Small arms: .22 through .50 caliber	Mortar, 4.2” and 60mm (HE, practice)
Rifle grenades, M9, M11, M17, and M29	Mortar, 81mm, and 87 mm (HE, practice, WhP)
Grenade, hand and rifle (fragmentation, illumination, practice, tear, and incendiary)	Rocket, 2.36” and 3.5” plus 35mm
Mine, anti-personnel	Shells, 105mm and 155mm; 3-inch and 5-inch
Torpedoes and bombs; bomblet AN-M50 incendiary	Antiaircraft: 20mm, 37mm, 40mm, 50mm, 54mm, 57mm, 75mm, 60mm, 75mm, and 90mm

Geology/Soils: The rock sequences consist primarily of volcanic rocks with some sedimentary rock. A relatively thin layer of unconsolidated material (generally less than 3 meters [10 feet thick]) covers the entire island. Only the downtown area is known to have a thick sequence of unconsolidated material (greater than 30 meters [100 feet]). The northern region of Adak is dominated by the remnants of three volcanoes, lava flows and ash. Most soils on the island are coarse-grained and are not susceptible to either freezing or heaving. Any fine-grained soils present would be at very low elevations (stream deltas, tidelands, and fill materials) and would therefore have a potential for freezing and heaving only to depths less than 30 centimeters (1 foot).

Climate: Polar maritime characterized by persistently overcast skies, high winds, frequent and often violent storms, and a narrow range of temperature throughout the year. The mean annual climatic data are: temperature 4 °C (40°F), rainfall 114 centimeters (45 inches), snowfall about 250 centimeters (100 inches) and wind speed 24 kph (15 mph). Weather on the island can vary dramatically over a short distance with localized fog, low ceilings, and precipitation, separated from areas with clear weather by only a few kilometers. Frost depth at 300 meters (1,000 feet) elevation is about 0.75 meters (2.5 feet).

Terrain: Three steep, highly weathered volcanic peaks dominate Adak Island. These peaks are cut by deep valleys resulting from erosion by streams that also provide runoff to the coastal areas. Deltaic and tidal lagoon areas are found near the coastline; however, steep rocky slopes or cliffs rising up to 760 meters (2,500 feet) characterize most of the coastline. The terrain includes steep ridges, deep ravines, and rolling hills. Very few areas of the island are flat, and grading to create flat areas could not be done easily. Mt. Moffett at 1181 meters (3,875 feet) is the highest point on the island.

Vegetation/Land Cover: The native vegetation is a terrestrial-maritime tundra ecosystem consisting of grasses, lichens, mosses, and other species adapted to the wet, cold, and windy polar climate. The island is treeless and dominated by mixed grasses, sedges, forbs, and low-growing woody heaths with lichens and mosses. Vegetation is lush from sea level to about 300 meters (1,000 feet) in elevation. Tussocks, referred to as “haystacks,” are one of the most predominant features and are often interspersed with hollows or holes in the ground under the vegetation. Low-growing plants are often thick and spongy, making access difficult even on level terrain.

Note: Ordnance listed is for the entire facility as reported in the administrative record, rather than the example range.

Indirect-Fire Range, Adak, AK, Mitt Lake Mortar Range Impact Area

Site-Specific References – Adak NAF

- Foster Wheeler Environmental Corporation and Environmental Chemical Corporation, 2001. Final Remedial Investigation / Feasibility Study Report for OUB1 Sites, Former Naval Air Facility, Adak Island, Alaska. Prepared for Commanding Officer, Engineering Field Activity, Northwest Naval Facilities Engineering Command, Poulso, Washington, July 13, 2001
- Foster Wheeler Environmental Corporation and Environmental Chemical Corporation, 2002. Draft Final After-Action Report - 2001 Field Season, Former Naval Air Facility, Adak Island, Alaska. Prepared for Commander, Engineering Field Activity Northwest Naval Facilities Engineering Command, Poulso, Washington, March 2002
- Foster Wheeler Environmental Corporation, 2003. Final After-Action Report for 2002 Field Season for OU B-1 Sites, Former Naval Air Facility, Adak Island, Alaska. May 07, 2003
- Foster Wheeler Environmental, 2000. Draft Final Preliminary Assessment Report, Selected Areas of Concern in Operable Unit B, Former Naval Air Facility, Adak, Alaska. RAC I/Delivery Order No. 0083, Foster Wheeler Environmental Corporation, Anchorage, AK. December 01, 2000
- Foster Wheeler Environmental, 2000. Draft Site Investigation Report, Selected Areas of Potential Concern in Operable Unit B, Former Naval Air Facility, Adak, Alaska. Navy RACI/Delivery Order No. 0083, February 7, 2000
- U.S. Navy, 2001. Final Record of Decision, OU B-1, U.S. Navy, Naval Facilities Engineering Command (NAVFAC), Engineering Field Activity, Northwest, Poulso, WA, October 31, 2001

Indirect-Fire Range, Adak, AK, Mitt Lake Mortar Range Impact Area

General Site Description

Adak Island is located approximately 1,200 air miles southwest of Anchorage, Alaska, in the Aleutian Island chain (Figure ADI-1). In 1959, Public Land Order 1949 designated the northern portion of Adak for use by the Navy for military purposes. The Navy manages approximately 79,200 acres of the northern portion of the island, which is owned by the U.S. Department of Interior. The southern portion is both owned and managed by the U.S. Department of Interior through the U.S. Fish and Wildlife Service. The total land area of the island is approximately 180,000 acres or 280 square miles. Development of Adak was limited to the northern portion of the island.

Because of its strategic location, Adak was selected by the military as a base of operations to counteract the Japanese invasion of World War II. The U.S. Army established a base on the island in 1942; by the summer of 1943, about 100,000 soldiers and 100 ships were stationed at the base. Immediately following the end of World War II, the military presence on the Island dramatically declined. The U.S. Army controlled operations in the downtown area until 1950, when the U.S. Air Force took control of the airfield and renamed it Davis Air Force Base. The Adak Naval Complex had two main developed areas: former Naval Air Facility (NAF) Adak and Naval Security Group Activity (NSGA). Land uses at the former NAF Adak—located in the developed “downtown” area—include the airfield, port facilities, and light industrial, administrative, commercial, recreational, and residential areas. NSGA is located approximately 5 miles north of NAF Adak, at the northwestern corner of Clam Lagoon. NSGA ceased all operations in 1995.

The Navy conducted seaplane operations in Andrew Lake, Clam Lagoon, and Albert Mitchell Field from 1943 to 1959, when all operations were moved to Davis Field. Adak NAF was placed on the NPL in 1994. In 1995, NAF Adak was listed for closure under BRAC and the facility formally closed in March 1997.

The structures and road system remain, but the area is not inhabited. A caretaker contract was awarded on April 1, 1997, to maintain base facilities and continue services in functional areas that include billeting, food, water and wastewater, fuel, power, heating, and airport operations. Approximately 200 personnel are living and working on Adak at this time.

Since 1995 the Navy has been facilitating private-party economic reuse on Adak. An integral part of this reuse is a land-exchange agreement that would transfer a portion of the current military reservation from the federal government to The Aleut Corporation (TAC). Completion of the land exchange requires the Navy to meet requirements established by the Department of Defense Explosive Safety Board (DDESB) for transfer of real estate potentially contaminated with MEC. In addition, CERCLA requires the Navy to perform remedial actions to protect human health and the environment. One or more RODs must be signed by the Navy, EPA, and the Alaska Department of Environmental Conservation (ADEC) prior to land exchange.

The FFA was modified in January 1999 to include a new operable unit, OU B, to deal with ordnance issues. OU B was subsequently divided into OU B-1 and OU B-2 to facilitate assessment, cleanup, and transfer of property. OU B-1 is the portion of the military reservation that contains the core of the proposed reuse area.

Indirect-Fire Range, Adak, AK, Mitt Lake Mortar Range Impact Area

The ROD for OU B-1 was signed in December 2001. The ROD for OU B-2 is pending as of August 2005. Figure ADI-2 was taken from the Adak OU B-1 proposed plan (see website <http://adakupdate.com>) and shows the locations of the many individual ranges within OUB-1 (dark gray shading) and OU B-2 (unshaded area) in the northwest corner of the figure. As noted in the OU B-1 ROD, there are 131 MEC sites within OU B-1 and no further action was selected as the remedy for 104 of the 131 sites. OU B-2 is still in the early stages of assessment and there is little information available on this area.

The cleared area selected for an example is the Mitt Lake Mortar Range Impact Area or ML-01 which comprised only about 14.7 acres. The data and statistics below pertain only to the area cleared in ML-01 and cannot be extrapolated to the entire installation.

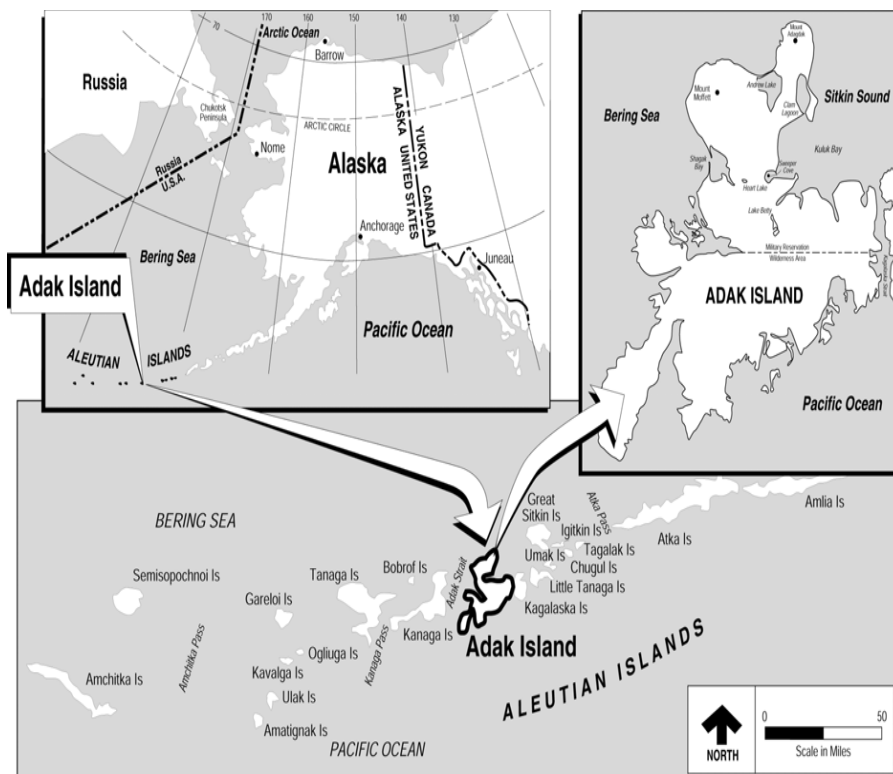

Source: U.S. Navy, 1999

Figure ADI-1. Adak Location Map

Indirect-Fire Range,; Adak, AK, Mitt Lake Mortar Range Impact Area

Range Area Description

Mitt Lake Range

The Mitt Lake area is located in the south central portion of the former base. The northern end of the sector where Mitt Lake is located is dominated by lowlands cut by deep meandering streambeds. Mitt Lake, which is surrounded by a marshy area, is near the northern boundary of the sector. The lowlands around the lake rise to rolling hills mid- sector and finally to a tall peak near the southern boundary.

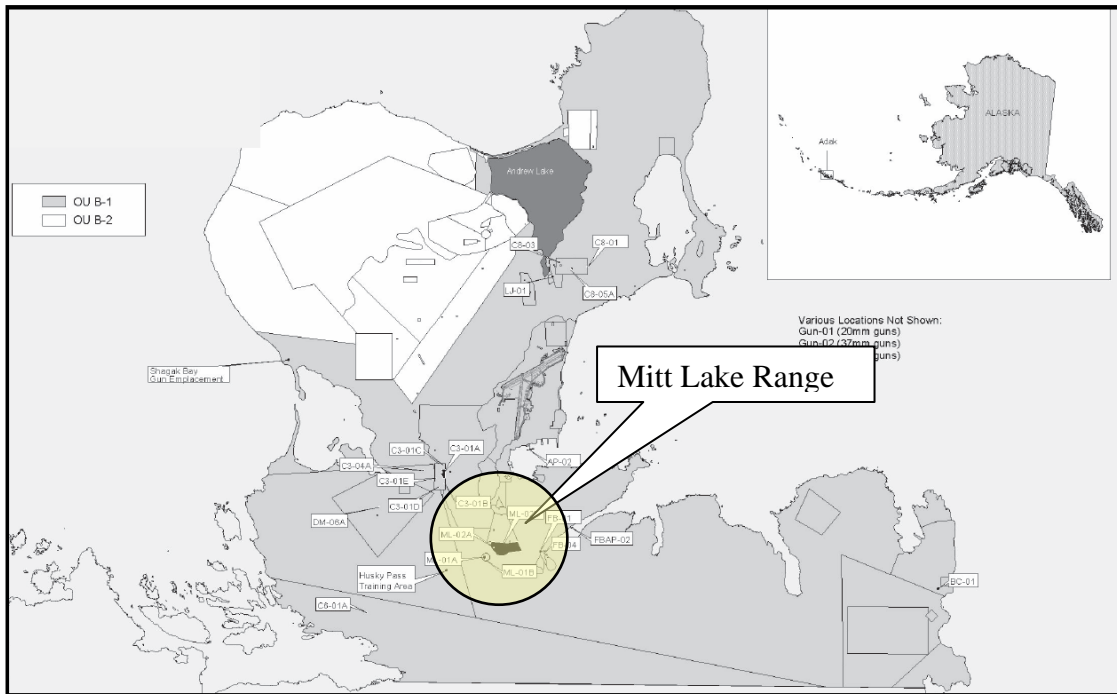

Source: <http://adakupdate.com>

Figure ADI-2. Map of Adak NAS, OU B-1 and OU B-2 with Individual Ranges

The vegetation in the Mitt Lake sector is varied. Tall grasses dominate the slopes, and short grasses, mosses, and wetland species account for a larger percentage of the vegetation in the lowland areas. Some of the ridge tops in this sector have the characteristic bare patches with rocky outcrops found in several other areas with steep ridges. The only apparent plants at these sites are small lichens on the rock surfaces.

The site originally consisted of five areas of concern (ML-01 through ML-05) (Figure ADI-2). However, after geophysical and intrusive investigations were completed as part of the RI in 2000, ML-03 and ML-04 did not warrant further consideration. The Mitt Lake Impact Area is a triangular area with the apex near the north shore of the lake and the base of the triangle some 1980 meters (6,500 feet) to the south. This area was identified from 13 historical firing orders, which contained the left and right limits of fire and indicated that the direction of fire was generally over Mitt Lake from the Trappers Cabin Valley area. Many of the firing orders further

Indirect-Fire Range, Adak, AK, Mitt Lake Mortar Range Impact Area

specify that test rounds were fired “into the mountain at the head of the valley.” A single firing order for this area specifies that the target for this particular exercise was to be a towed target. The order does not specify whether or not this was an aerial target or a target towed on the ground. The total area of concern is about 15 acres but the mortar impact area is a small part (3.5 acres) of the range and has been referred to as ML-01A.

The boundaries of the site were developed for the 2000 RI based upon the bearing of fire listed in numerous firing orders, left and right limits of fire listed in many firing orders, the range of the weaponry described in the firing orders, and the topographic features (such as ridges) that would partially define the overall range area. The candidate site boundaries included all subareas of the range, including the firing point, impact area, and range safety fan.

Historical information indicates the site was used to test-fire three types of weapons: 40mm guns firing self-destructive projectiles, 20mm guns firing explosive tracer bullets (projectiles), and .50 caliber guns firing AP and tracer bullets. The firing orders generally indicate that 12 rounds were fired from each of 25 guns during the approved test-firing exercises. The Mitt Lake Impact Area was investigated at accessible locations during the 1999 field season, and several pieces of UXO or ordnance-related scrap were found.

ML-01—60mm Mortar Impact Area

This site is located in the southwest corner of the Mitt Lake area (Figure ADI-3). ML-01 is separated from the other immediate MRS by a ridge. The terrain in this location is characterized by steep rolling hills with rocky outcrops on the hilltops. Steep stream ravines bisect the landscape carrying runoff down from the ridgeline. The vegetation is upland tundra ranging in height from 8 to 20 centimeters (3– 8 inches).

This area of potential concern (AOPC) was identified based upon the 2000 RI. During the RI, three 60mm mortars were found in this area, along with associated fragments. The area is located behind a ridgeline, which prevents the site from being a potential target for the historical firing point for the Mitt Lake Impact Area. In addition, the type of ordnance/scrap found is inconsistent with that listed in the firing orders.

The boundaries for the MRS were developed using the outer envelope of the ordnance contamination and the circular error probability (CEP) for the 60 mm mortars found in this area. Initially, each of the outermost ordnance-related finds were surrounded with a circle having a diameter equal to 75 percent of 4 times the CEP (6 meters) for 60 mm mortars (approximately 24 meters). These circular areas were then enclosed with an overall boundary to maximize the probability of enclosing additional ordnance-related materials within the AOPC boundary.

UXO Removal

The Mitt Lake Mortar Range and Impact Area (ML-01) was cleared during a series of removal actions conducted in 2001 and 2002. Approximately 14.7 acres were cleared to a depth of 1.2 meters (4 feet). A summary of the items recovered is shown in Table ADI-1.

Indirect-Fire Range,; Adak, AK, Mitt Lake Mortar Range Impact Area

The density of the recovered ordnance and fragmentation indicates that ML-01 was used as a discrete impact area for 60mm mortars. The density of the UXO and clutter are shown in Table ADI-2 and the grid density statistics are presented in Table ADI-3. The depth frequency distribution by item class is shown in Table ADI-4 and the recovery depths of MEC items are listed in Table ADI-5. The lateral frequency distribution of MEC items is presented in Figure ADI-4. The distance distribution was derived by calculating a center point from the center of MEC items found based on density and then measuring the distance of each item found from the center point.

Table ADI-1. Summary of Items Recovered from Mitt Lake Mortar Range Impact Area

Range Area	Area		UXO	Clutter				Mass Recovered (lbs)			Clearance Depth
	Sq. Ft	Acres		MEC	Non_MEC	No Find/ No Dig	Totals	MEC	Non-MEC	Total	
Mitt Lake Mortar Range Impact Area ML-01	640,500	14.7	28	27	103	68	226	69	2434	2503	4'

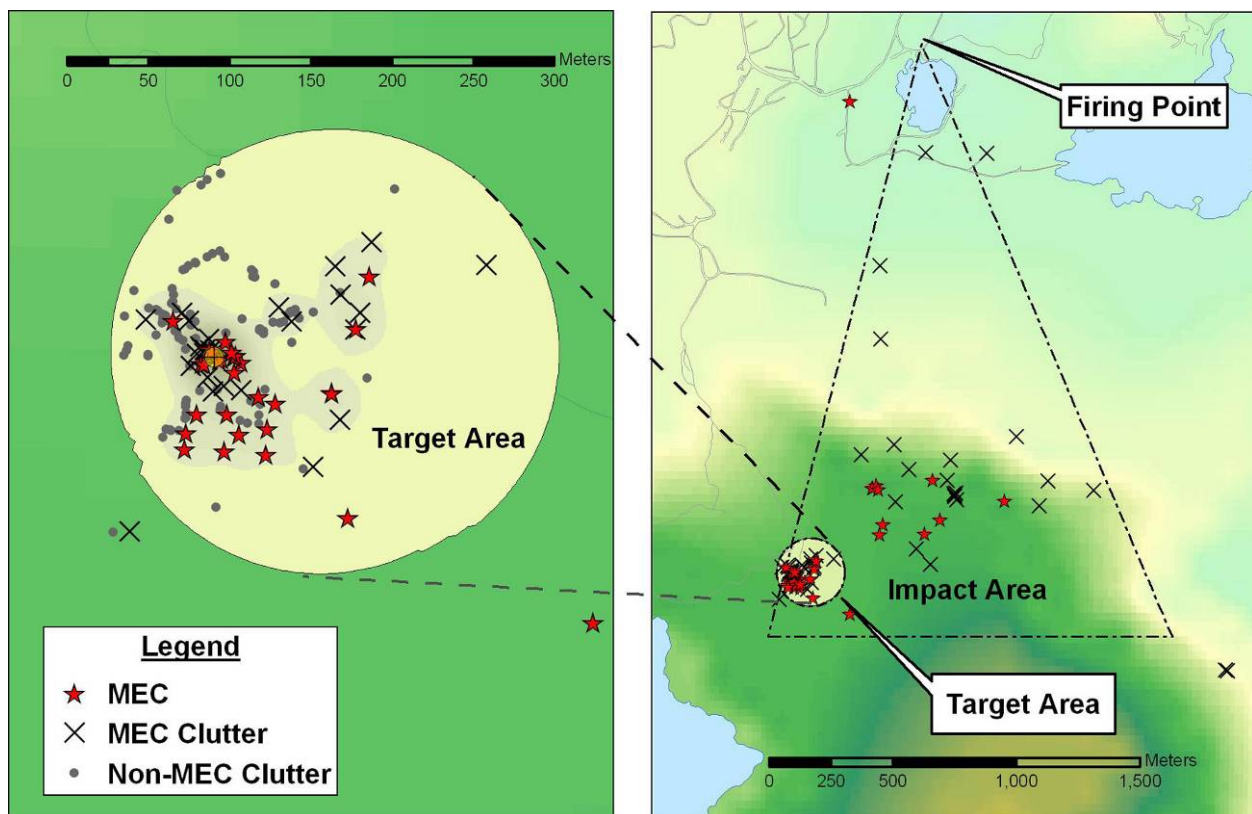

Figure ADI-3. Geographic Location of ML-01 Mitt Lake Mortar Range

Indirect-Fire Range, Adak, AK, Mitt Lake Mortar Range Impact Area

Table ADI-2. Density Summary, Mitt Lake Mortar Range Impact Area

Site	Area		Average Item Density (#/acre)					Mass Density (lbs/acre)		
	Sq. Ft	Acres	MEC	MEC Clutter	Non-MEC Clutter	No Find/No Dig	Totals	MEC	Non-MEC	Total
Mitt Lake Mortar Range Impact Area ML-01	640,500	14.7	1.9	2	7	5	15	5	166	170

Table ADI-3. Grid Density Statistics

Site	Included Types	Min	Max	Mean	SD
Mitt Lake Mortar Range Impact Area ML-01	MEC + Non-MEC	0	76.4	2.4	7.4

* Note - Generated by GIS density calculation tool using a distance-weight algorithm. Search radius was 100'. Output grid size was 5' x 5'.

Table ADI-4. Depth Frequency Distribution

Depth (in)	Numerical Distribution				Percentage Distribution			
	Non-MEC	MEC Clutter	UXO	All Types	Non-MEC	MEC Clutter	UXO	All Types
Surface	41	2	2	45	40%	7%	7%	28%
>0 - 2	22	4	7	33	21%	15%	25%	21%
>2 - 6	36	18	12	66	35%	67%	43%	42%
>6 - 12	3	3	6	12	3%	11%	21%	8%
>12 - 24			1	1			4%	1%
>24 - 36								
>36 - 48	1			1	1%			1%
>48								
All Depths	103	27	28	158				

Indirect-Fire Range,; Adak, AK, Mitt Lake Mortar Range Impact Area

Table ADI-5. Recovery Depth of MEC Items

Description	Depth_in
60mm Mortar	0
60 mm Fuze	1
60mm Mortar (4)	2
60mm Mortar Primer AOE	2
20mm HE; Fired	8
60mm Mortar, HE, M49	9
60mm Mortar w/Fuze	10
60mm Mortar, HE, Fuzed	12
60mm Mortar, HE (3)	0 to 1
60 mm Mortar w/Fuze (14)	0 to 8
60mm Mortar	3 to 14

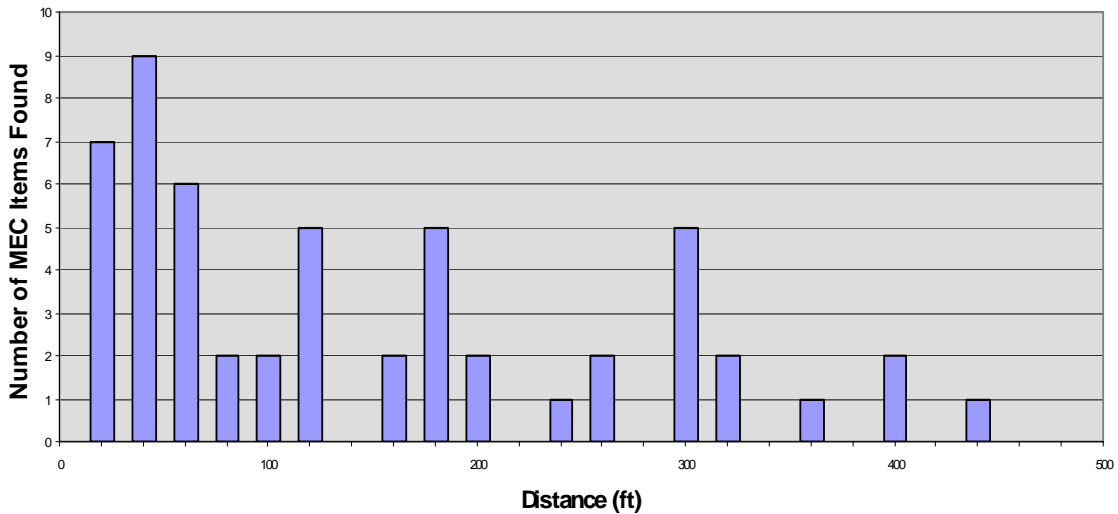

Figure ADI-4. Number of MEC Items Found Versus Radial Distance from Impact Center

Indirect-Fire Range, Adak, AK, Mitt Lake Mortar Range Impact Area

Indirect Fire Range: Fort Ritchie, MD, Combat Range/Quirauk Mountain

Range Overview

General Facility Description:

Fort Ritchie was established as Camp Ritchie in 1926 and used as a training area for the Maryland National Guard. Camp Ritchie was originally about 580 acres and rested partly on the slope of Quirauk Mountain and in the valley below. In World War II, the camp was leased by the U.S. Army for the war department's Military Intelligence Training Center (MITC) and expanded to 631 acres in 1940. Both the national guard and the MITC have used various ranges, especially targets on the side of Quirauk Mountain for mortar and artillery fire. In 1945, the MITC was deactivated and the Maryland National Guard re-instituted training. In 1948, the Army reacquired the site to support the Alternate Joint Communications Center (AJCC), the primary mission since the mid-1950s. The fort was officially closed in 1998 after being selected for closure in the 1995 BRAC round. The former fort has not been listed as a CERCLA site.

Location: Cascade, MD

Size: 631 acres

Range Types:

Artillery, machine gun, mortar and small arms (pistol, rifle) ranges

Typical Ordnance Types:

Bomb, 50lb (MKI-practice)	Mortar, 3" stokes (HE, practice)
Booby trap simulator	Mortar, 4.2" and 60mm (HE, practice)
Small Arms: .30, 45 and .50 caliber (AP, ball, tracer, and incendiary)	Mortar, 81mm, (HE, practice, WhP)
Fuze, (grenade-rifle,rocket-2.36")	Mortar, German 50mm, Japanese Type 89
Hand and Rifle Grenades (incendiary, illumination, tear, and practice)	Rocket, 2.36"
Mine, anti-personnel (practice)	Shell, 37mm (practice, APT), 57mm (practice), 75mm, and 105mm (HE),
	Signals, illuminating

Geology/Soils:

Bedrock in the area is primarily older metamorphic rocks (quartzite, metabasalt and gneiss) with some sandstone. Soils are mainly upland soils formed from the underlying bedrock. Soil thickness varies from 0 to 1.2 meters on the side of Quirauk Mountain but can be up to 9 meters deep in the valley. Soils consist of clay with varying amounts of silt, sand and gravel. Metabasalt pebbles and clasts have a ferromagnetic signature and are found throughout the site.

Climate:

The mean annual temperature is 50 to 55°F and rainfall is about 99 centimeters per year. Normal frost depth is 81 centimeters. Snowfall is about 69 centimeters per year in nearby Hagerstown, Maryland.

Terrain:

The site is in the Blue Ridge physiographic province of the Appalachians Highlands division. The province consists of alternating mountain ridges and valleys. The site lies at the foot of Quirauk Mountain and extends into the valley below. Slopes are wooded, rocky, and steep (10% to 30%) and relief is about 130 meters. Lake Royer (with an upper and lower dam) is located in the valley part of the facility. Wetlands surround the lake and its feeding stream.

Vegetation/Land Cover:

The slope of Quirauk Mountain is undeveloped and tree covered and is heavily wooded in places with significant underbrush. Wetlands are associated with Lake Royer and its feeding stream on the south and west side of the former base; these areas are also undeveloped. The remaining area of the base is fully developed with a wide variety of land uses typical to a military installation.

NOTE: Ordnance types listed are for the facility rather than the example range.

Indirect Fire Range: Fort Ritchie, MD, Combat Range/Quirauk Mountain

Site-Specific References – Fort Ritchie

- IT Corporation, 1999. Ordnance and Explosives Engineering Evaluation/Cost Analysis (EE/CA), Fort Ritchie Army Garrison, Washington County, Maryland. Prepared for the U.S. Army Corps of Engineers, Baltimore District, September 2000.
- Shaw Environmental, 2003. Fort Ritchie Army Garrison Non-Time-Critical OE Removal Action, Ordnance and Explosives Removal Action Report, Final Document. Prepared for U.S. Army Corps of Engineers, Baltimore District, Maryland, April 2003
- USACE-St. Louis, 1996. Final Archives Search Report, Conclusions and Recommendations, Fort Ritchie, Washington County, MD. U.S. Army Corps of Engineers, St Louis District, December 1996.

Indirect Fire Range: Fort Ritchie, MD, Combat Range/Quirauk Mountain

General Site Description

Fort Ritchie is located approximately one mile south of the Maryland/Pennsylvania border in Washington County, adjacent to the town of Cascade, Maryland (Figure FRI-1). It is situated near the upper end of a small valley at the foot of Quirauk Mountain, which is part of the South Mountain ridge of the Appalachian Mountains. It was selected for closure in the 1995 BRAC round.

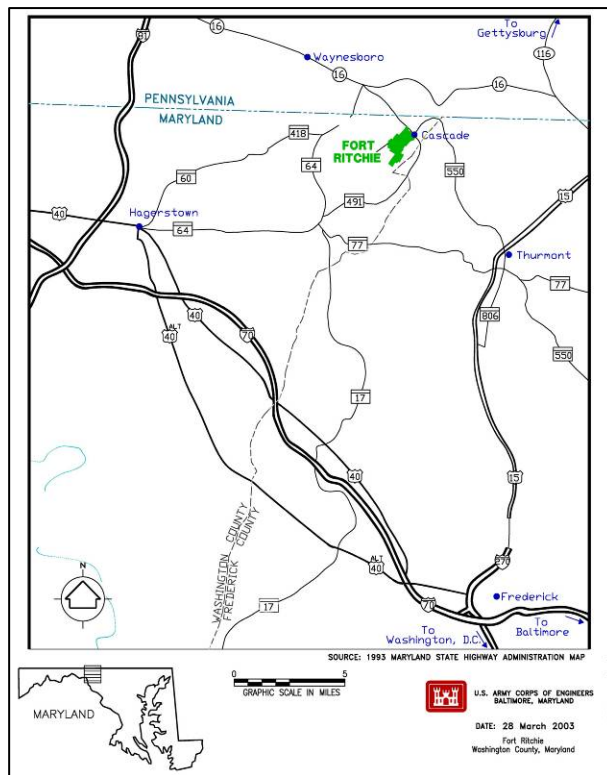

Source: Shaw Environmental, 2003

Figure FRI-1. Map of Fort Ritchie

In preparation for BRAC transfer of the property, an Archive Search Report (ASR) was developed by the USACE soon after the installation was placed on the BRAC list. The entire installation was evaluated for the types and probable location of MEC. The ASR suggested a potential for UXO in certain areas in the west and southwest portions of former Fort Ritchie.

An Action Memorandum developed for the former Fort Ritchie stated that the future land use should remain largely unchanged. A future land-use plan was prepared by the redevelopment authority, which focuses on broad, generic areas of proposed reuse that can be developed and marketed to the private sector. According to the plan, the land will become a technology and conference center consisting of office buildings, conference halls, and associated infrastructure. Residential areas will remain, although to a lesser extent than historically existed.

An EE/CA sampling investigation was initiated in 1997 to sample a representative portion of the areas indicated by the ASR as potentially containing UXO. The purpose of the EE/CA sampling investigation was to confirm the presence and determine the amount of UXO present in

Indirect Fire Range: Fort Ritchie, MD, Combat Range/Quirauk Mountain

ASR areas. The area of potential concern was divided into six sectors and the EE/CA looked at five of the six sectors (Sectors 1, 3, 4, 5, and 6). Sector 2, was originally identified in the ASR as a potential UXO area but was removed from consideration in the ASR and the EE/CA due to a lack of evidence supporting UXO in this sector. The area of interest in this example is labeled “Sector 6” in Figure FRI-2. Sector 6 is located on the western portion of Fort Ritchie, on the eastern slope of the Quirauk Mountain. It is a rocky, steeply sloped, wooded area.

The majority of Sector 6 is currently undeveloped. According to the redevelopment company, the future land use will remain open space with the following exceptions: the eastern portion—adjacent to the existing developed areas—could be developed as commercial in the future while the northern portion could be developed as residential. The SDZ for the mortar range areas includes Sectors 1, 4, and 6, with Sector 6 being the impact area. Sector 6 is comprised of “Sector 6” and “Sector 6 off site,” which are about 120 and 20 acres, respectively. These areas were cleared to a depth of one foot during the removal actions that occurred from June 2001 through October 2002.

Indirect Fire Range: Fort Ritchie, MD, Combat Range/Quirauk Mountain

Range Area Description

Combat Mortar Range, Quirauk Mountain Hillside (Sectors 1, 4, and 6)

The area cleared for the Combat Mortar Range was 172.8 acres. The data and statistics below pertain only to the Combat Mortar Range as specified and cannot be extrapolated to the entire installation.

The central portion of Sector 6 consists of the impact area for the Military Intelligence Training Center (MITC) target range. The MITC reportedly fired various mortars and projectiles ranging from 37mm to 105mm. The 1996 ASR indicated that the target range was used by the MITC to conduct live firing exercises and weapons demonstration. Small and heavy machine guns, grenades, mortars, 37mm guns, and 105mm howitzers were fired on the range west-northwest toward Quirauk Mountain. The training involved both foreign and domestic weapons. The southern portion of Sector 6 contains the National Guard 914 meter (1,000-yard) known distance range target. The ASR indicated that historical records did not indicate which types of weapons were fired on the range; however, 3-inch Stokes mortars were uncovered during excavation on and nearby the range. Evidence collected during the development of ASR for similar installations indicates that National Guard troops found 914 meter (1,000-yard) known distance ranges to be ideal locations for the proof testing and firing of Stokes mortars.

A total of 15 UXO items were found in Sector 6 during the EE/CA investigation: six 37mm shells, two 57mm mortars, two 60mm mortars, three 81mm mortars, one type 89 58mm Japanese knee mortar, and one 5cm German bomb. All of these items were HE-filled, with the exception of one 81mm mortar which contained white phosphorus. Two more UXO—an 81mm mortar and a 60mm mortar—were found on the surface during non-MEC debris removal activities in the spring of 1999. All UXO in Sector 6 during the EE/CA were found within 38 centimeters (15 inches) of the ground surface. The shallow depth to bedrock may have limited ordnance penetration in the Sector 6. In 1999, preparatory activities for the removal action began and actual UXO excavation and disposal occurred from June 2001 through October 2002. Figure FRI-2 is a survey and ordnance removal map of Sector 3 and adjacent sectors developed from data collected during the removal actions.

A summary of the combat mortar range areas—including the cleared area, number of items found, and mass recovered during the removal action—is presented in Tables FRI-1 and FRI-2. Table FRI-3 is the grid density statistics, and Table FRI-4 summarizes the MEC recovered during the removal action.

Table FRI-5 summarizes the anomaly depth frequency distribution by type, and Table FRI-6 provides a summary of the types of MEC recovered.

Indirect Fire Range: Fort Ritchie, MD, Combat Range/Quirauk Mountain

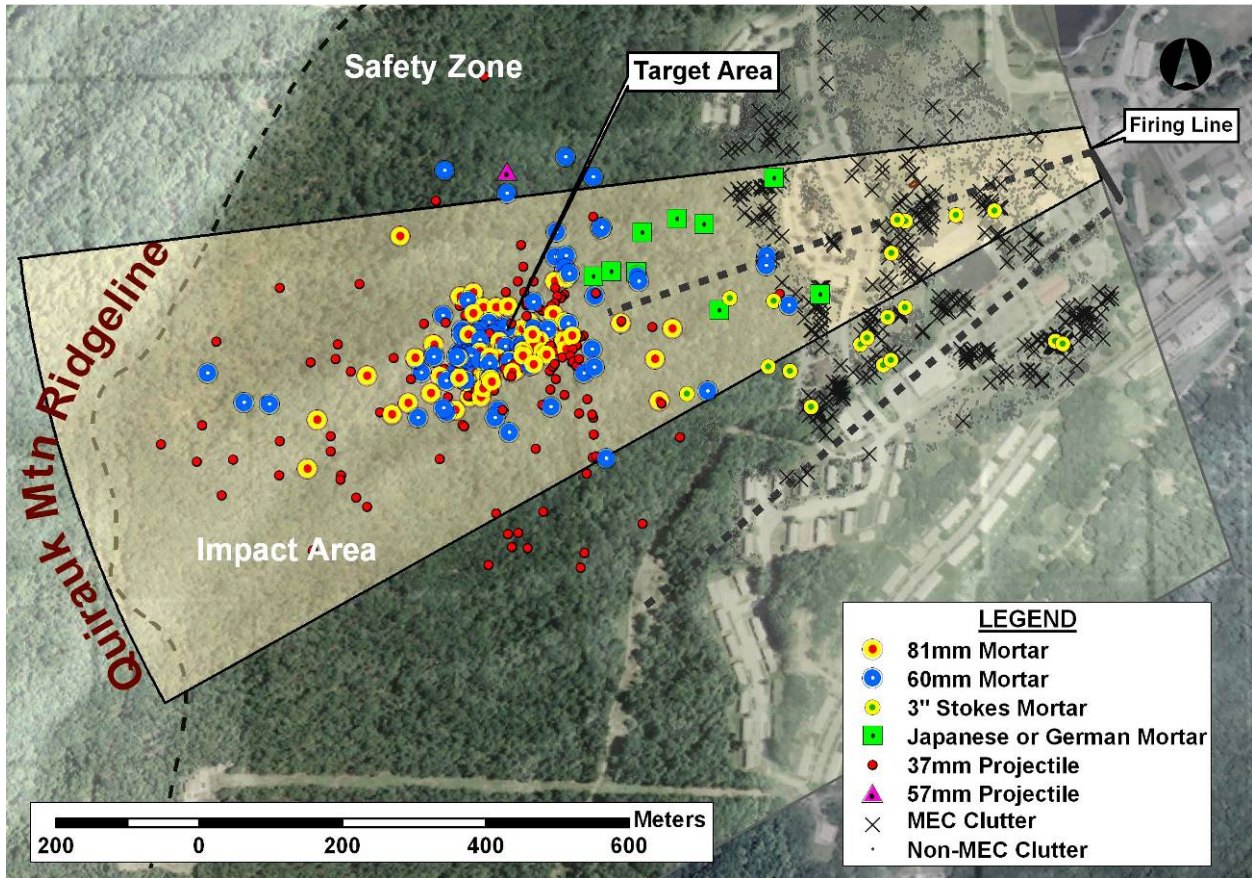

Figure FRI-2. Fort Ritchie Combat Mortar Ranges with MEC Locations

Table FRI-1. Fort Ritchie, Summary of Combat Mortar Range

Sector Area	Clearance Depth (ft)	Cleared Area		Number of Items Found				Mass Recovered (lbs)		
		Sq. Ft	Acres	MEC	MEC Clutter	Non-MEC Clutter	Totals	MEC & MC	Non-MEC Clutter	Total
1	4	781,337	17.9	14	216	4,583	4,813	1,185	5,188	6,373
4	4	588,404	13.5	6	111	2,928	3,045	254	2,288	2,542
6	4	5,274,586	121.1	279	48,971	22,464	71,714	6,495	1,210	7,705
6 - "Off-site"	1	883,640	20.3	30	8,031	6,760	14,821	771	396	1,167
Totals		7,527,966	172.8	329	57,329	36,735	94,393	8,705	9,082	17,787

MEC - munitions and explosives of concern
 MC - MEC clutter

Indirect Fire Range: Fort Ritchie, MD, Combat Range/Quirauk Mountain

Table FRI-2. Fort Ritchie Sector 6, Combat Mortar Range, Density Summary

Sector Area	Clearance Depth (ft)	Cleared Area		Average Item Density (#/acre)				Mass Density (lbs/acre)		
		Sq. Ft	Acres	MEC	MEC Clutter	Non-MEC Clutter	Total	MEC	Non-MEC Clutter	Total
1	4	781,337	17.9	0.8	12.0	256	268	66	289	355
4	4	588,404	13.5	0.4	8.2	217	225	19	169	188
6	4	5,274,586	121.1	2.3	404.4	186	592	54	10	64
6 - "off-site"	1	883,640	20.3	1.5	395.9	333	731	38	20	58
Total		7,527,966	172.8	1.9	331.7	213	546	50	53	103

MEC - munitions and explosives of concern
 MC - MEC clutter

Table FRI-3. Fort Ritchie Sector 6, Combat Mortar Range, Grid Density Statistics

Area	Total Number of Grids	Grids Without Anomalies	Measure	Item Type		
				MEC	MEC Clutter	Non-MEC Clutter
Sector 6 - 1' Clearance Grids	569	11	Number of Grids Found	516	530	109
		2%	Percent of Total Grids	91%	93%	19%
			Maximum (#/acre)	17198	3136	48
			75th Percentile	1882	588	13
			Mean	419	199	10
			Median	112	139	4.4
			25th Percentile	11	25	4.4
			Minimum	4.3	4.2	4.3
Sector 6 - 4' Clearance Grids	101	6	Number of Grids Found	92	93	21
		6%	Percent of Total Grids	91%	92%	21%
			Maximum (#/acre)	3437	2496	35
			75th Percentile	396	510	4.4
			Mean	402	422	7.0
			Median	231	274	4.4
			25th Percentile	113	187	4.4
			Minimum	8.0	34.8	4.4
Total:	670	17				

Indirect Fire Range: Fort Ritchie, MD, Combat Range/Quirauk Mountain

Table FRI-4. Fort Ritchie, Sector 6, MEC Recovery Depth

Category	Type	Purpse	Model Series	Diameter (mm)	Number Recovered	Depth Found (in)		
						Min	Max	Avg
Grenade	Hand	Frag	MK II	57	1	30	30	30
		Practice	MK 1A1	57	1	12	12	12
	Rifle	AT	M9 Series	57	1	30	30	30
Mortar	3-inch Stokes		(Unknown)	76	14	6	48	20
		HE	MK I	76.2	1	48	48	48
	50 mm, German		(Unknown)	50	1			
	50 mm, Japanese	HE	"Knee Mortar, Type 89	50	9	4	4	4
	60 mm	HE	M49 Series	60	71		6	2
		Practice	M50 Series	60	11			
	81 mm	HE	M43 Series	81	53			
HE		M56	81	15				
Smoke (WP)		M57 Series	81	5				
Projectile	37 mm		(Unknown)	37	134		8	1
	57 mm	TP	M306 Series	57	1			
Rocket	2.36-inch		(Unknown)	60	7		18	9
		HEAT	M6 Series	60	4	18	18	18
Totals					329			

Table FRI-5. Fort Ritchie, Sector 6, Anomaly Depth Frequency Distribution by Type

Depth (in.)	Anomaly Counts*				Relative Percentages			
	MEC	MEC Clutter	Non-MEC Clutter	Totals	MEC	MEC Clutter	Non-MEC Clutter	Totals
Sectors 1, 4, and 6 (4' Clearance Depth)								
Surface	3	7	126	136	6%	2%	2%	2%
>0 - 6	2	102	1992	2096	4%	35%	37%	36%
>6 - 12	4	85	1331	1420	8%	29%	24%	25%
>12 - 24	4	63	1028	1095	8%	22%	19%	19%
>24 - 36	3	19	257	279	6%	6.5%	4.7%	4.8%
>36 - 48	2	15	704	721	4%	5.2%	13%	12%
>48								
Unknown	32		3	35	64%		0.1%	1%
Totals	50	291	5441	5782	100%	100%	100%	100%
Sector 6 (1' Clearance Depth) - MEC Only								
Surface	14				5%			
>0 - 6	3				1%			
>6 - 12	1				0.4%			
>12 - 24								
>24 - 36								
>36 - 48								
>48								
Unknown	261				94%			
Totals	279				100%			

* Based primarily on anomalies surveyed with EM-61, except for MEC items which include Schonstedt-located items.

MEC - munitions and explosives of concern

MC - MEC Clutter

Indirect Fire Range: Fort Ritchie, MD, Combat Range/Quirauk Mountain

**Table FRI-6. Fort Ritchie, Combat Mortar Range Area,
MEC and Clutter Type Summary**

Item				Diameter (mm)	Sector					Total
Category	Type	Purpose	Model Series		1		4		6	
					MEC	MC	MEC	MC	MEC	
Mortar	3 Inch Stokes			76	8	148	1	28	5	190
		HE	Mk I	76.2	1					1
	50 mm, German			50					1	1
	50 mm, Japanese	HE	"Knee Mortar", Type 89	50			2		7	9
	60 mm			60				6		6
		HE	M49 Series	60			1		70	71
		Practice	M50 Series	60					11	11
	81 mm	Training	M69	60						0
				81		1		7		8
		HE	M43 Series	81					53	53
			M56	81					15	15
	Projectile	37 mm	Practice	M43 Series	81					0
Smoke (WP)			M57 Series	81				5	5	
40 mm				37		13		4	134	151
		AP-T		37				2		2
57 mm	Riot (CS)	M674	37						0	
57 mm	TP	M306 Series	57					1	1	
Rocket	2.36 Inch			60	1	18	1	9	5	34
		Heat	M6 Series	60	1		1		2	4
		Motor		60		7		7		14
		Practice	M7 Series	60		1		2		3
Grenade	Hand	Frag	Mk li	57	1					1
		Incen	Th3, An-M14	64						0
		Practice	M30	57				1		1
			Mk 1a1	57	1					1
	Rifle	(Unknown)								0
		AT	M9 Series	57	1					1
AT, Practice	M11 Series	57					1		1	
Small Arms						7		7		14
Fragment	(Unknown)							7		7
Flare	(Unknown)							5		5
	Parachute	Trip	M48			1				1
Canister	Gas	Riot (CS)				2		1		3
Signal	Illum							1		1
		Ground, Parachute, Rifle	M19 Series					2		2
Fuze	(Unknown)									0
	Hand Grenade					1				1
Scrap Metal	(Unknown)							2		2
Grand Total					14	199	6	92	309	620

Indirect Fire Range: Fort Ritchie, MD, Combat Range/Quirauk Mountain

Indirect Ranges: Other Examples

Presented below are two examples of the depths at which munitions and clutter have been found at two other indirect fire ranges: the Badlands Bombing Range/Impact Area (Figure IO-1) and the Artillery Range (Long Range) from Camp Croft (Figure IO-2). In Figure IO-1, two types of surveys were conducted and the results from the airborne geophysical survey are shown with yellow triangles while the results from a ground-based MTADS survey are shown using green diamond-shaped symbols. Both figures show a narrow range in the diameters of the items found as might be expected given that these two ranges were used for specific weapons systems.

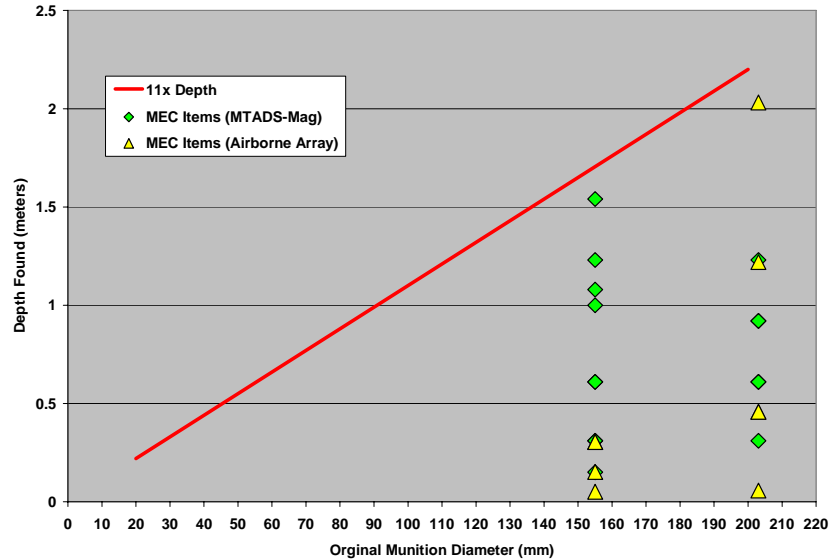

Figure IO-1. MEC and Clutter Items, Diameter versus Depth at the Badlands Bombing and Gunnery, Artillery Impact Area

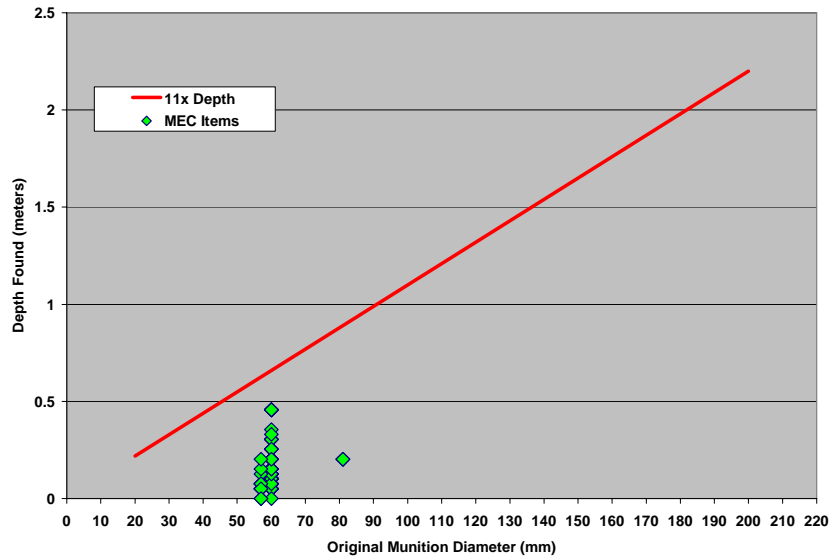

Figure IO-2. MEC and Clutter Items, Diameter versus Depth at the Camp Croft Range (Mortars and Hand Grenades)

Site-Specific References – Badlands Bombing Range

Parsons, 2003. Final Engineering Evaluation and Cost Analysis Report for the Badlands Bombing Range, Volume I, Revision 1. Prepared for U.S. Army Engineering Support Center, Huntsville, Alabama and U.S. Army Corps Of Engineers, Omaha District, Nebraska, May 2003

Parsons, 2003. Final Engineering Evaluation and Cost Analysis Report for the Former Badlands Bombing Range, Volume II. Prepared for U.S. Army Engineering Support Center, Huntsville, Alabama and U.S. Army Corps Of Engineers, Omaha District, Nebraska, May 2003

Parsons, 2003. Final Engineering Evaluation and Cost Analysis Report for the Former Badlands Bombing Range, Volume III. Prepared for U.S. Army Engineering Support Center, Huntsville, Alabama and U.S. Army Corps Of Engineers, Omaha District, Nebraska, May 2003

USACE-TEC, 1999. Badlands Bombing Range, GIS-Based Time-Sequence Analysis. USACE, Engineer Research and Development Center, Topographic Engineering Center, Alexandria, VA, September 1999.

USACE-Rock Island, 2000. Archive Search Report Findings for the Pine Ridge Gunnery Range. U.S. Army Corps of Engineers, Rock Island District, May 2000.

Site-Specific References – Camp Croft

UXB International, 2001. Final Removal Report, Ordnance Removal Action, Former Camp Croft, OOU-3 A, B, and C; OOU-6; and OOU-11C and D, Spartanburg, South Carolina. Prepared for the U.S. Army Corps of Engineers Engineering and Support Center, Huntsville, AL, April 2001.

Zapata Engineering, 2002. Site Specific Final Report, Former Camp Croft Army Training Facility, OOU-6, Spartanburg County, Spartanburg, South Carolina. Prepared for the U.S. Army Engineering and Support Center, Huntsville, September 2002

Appendix C—Bombing and Gunnery Range Examples

SITES

(LBGR) Lowry BGR (Buckley Field), Bombing Target (BT) #2

(CBGR) Conway BGR, SC, Range III

Bombing and Gunnery Range: Lowry BGR (Buckley Field), BT #2

Range Overview

General Facility Description: Buckley Field use and ownership has changed several times since the land was acquired by the city of Denver in 1937. The airfield and bombing range were used by the Army during World War II for bombing practice using both practice and HE bombs, and fixed and flexible gunnery targets. The range contained at least 12 different target areas. After World War II, the airfield became a Naval Air Station; the bombing range came under custody of Lowry AFB and was known subsequently as the Lowry Bombing and Gunnery Range. The Air Force continued to use the bombing range, added a demolition range at the west end of the bombing range, and later created the Lowry Training Annex. Ordnance found at the site indicated that Lowry AFB used the range in support of its air photography mission. A portion of the range was used for training support during the Vietnam War. Four titan missile sites were also constructed on the bombing range.

Location: Denver, CO

Size: 65,547 acres total for the bombing range and airfield

Range Types: One large range with multiple targets (ranges) within the complex that included: air-delivered weapons targets such as strafing and bombing targets, mortar, rocket, and small arms (pistol, rifle) ranges.

Typical Ordnance Types:	Photoflash bombs (M46); HE filled bombs
.30 and .50 caliber small arms	20mm, 30mm, 37mm, 40mm, and 75mm
Miniature practice bombs, 3 lb (Mk23)	Incendiary bombs, M74, AN-M69, and M50 Series
Bombs Mk1, Mk76	M15 WP grenade
practice bombs, 100 lb (M38)	M1A1 Spotting charges
practice rockets (2.5-inch SCAR and 2.75-inch)	M125 simulant filled
M142 and M152 bombs	500lb GP bomb
Signal illumination	Bomblet BDU-28

Geology/Soils: Soils are a brown silty to sandy clay alluvium that is 3-5 meters (10-15 feet) thick overlying a layer of medium grained sands that can be up to 24 meters (80 feet) thick. The consolidated Dawson and Denver Formations underlie the alluvial soils and consists of sandstones and shales that are typically found beginning at depths of 6 to 12 meters (20 to 40 feet).

Climate: The climate is best described as semi-arid continental. The average summer high temperature is 31°C (88°F) and the average winter low is -9°C (16°F). Precipitation is low at 40 centimeters (15.5 inches) per year and about one third of the precipitation occurs as snowfall which is about 150 centimeters (60 inches) per year. Humidity is low.

Terrain: Typical short grass prairie conditions prevail. The land is flat to very gently rolling and is free of rocks and terrain features that would hinder land-based geophysical surveys. Several small ephemeral drainages or creeks flow north- across the range which is elongated in an east-west direction. The Aurora Reservoir is located in the southwest portion of the range and abuts a 20mm firing range

Vegetation/Land Cover: The land surface is covered by sparse short grass, sedges, sagebrush, low shrubs. Trees are present along the small drainages and there is some dry land farming.

NOTE: Ordnance types listed are for the facility.

Bombing and Gunnery Range: Lowry BGR (Buckley Field), BT #2

Site-Specific References – Lowry Bombing and Gunnery Range

- MGC, 2000. Former Lowry Training Annex, Air Force EOD Range, Area C–Buffer Zone. Slide presentation, MicroGeophysics Corporation Wheat Ridge, CO, January 2000 (www.flbgr.org/pdfs/2000/FLTA/AirForce-2000-01-19.pdf)
- McDonald, J. R., H.H. Nelson, and R. Robertson, 1999. MTADS Live Site Survey, Bombing Target #2 at the Former Buckley Field, Arapahoe County, CO. NRL/PU/6110-99-379, Naval Research Laboratory, Washington, DC
- Blackhawk UXO Services, 2003. Geophysical Prove Out, Southshore Development Site, Former Lowry Bombing and Gunnery Range, Aurora, Colorado, Prepared For: Laing Village, LLC, July 10, 2003
- USACE-St. Louis, 1995. Archives Search Report Findings for Buckley Field, Arapahoe County, Colorado. U.S. Corps of Engineers, St. Louis District, May 1995

Bombing and Gunnery Range: Lowry BGR (Buckley Field), BT #2

General Site Description

The former Buckley Field included an airfield and bombing and gunnery ranges comprising 65,547 acres in Arapahoe County, CO, near the town of Aurora. Figure LBGR-1 is a map of the former Lowry Bombing and Gunnery Range. The bombing range was exercised in 1960. Approximately 3,700 acres of land known as the Lowry Training Annex was used by the Air Force until 1991. The remainder of the land is known as the former Lowry Bombing and Gunnery Range (NRL, 1999). The area is used primarily for cattle grazing. There is no evidence of substantial public use of the area.

The FLBGR was originally established on land acquired from the City and County of Denver in 1937. It opened in 1942 as an Army Airfield, and was part of the Army Air Corp's Western Technical Training Command during WWII, when it was used to conduct armament and bombing training. The training consisted of bombing practice using both practice and high explosive (HE) bombs at numerous bombing and gunnery targets across the site.

During World War II, Buckley Field had six bombing targets, a rocket and gunnery target, nine air-to-ground flexible gunnery targets, two ground-fixed gunnery targets, two air-to-ground gunnery targets, a nose and tail guns target, a jeep range, and three training camps (USACE, 1995). These facilities were heavily used in World War II by Buckley Field, Lowry Field, other Second Air Force installations such as Peterson Field, and the Army Air Forces Proving Ground Command for series and precision bombing and air-to-ground gunnery. From 1942 through 1963, numerous tenants, including the Air Force, Army, Navy, and Air National Guard, used the range for various training exercises. The range was also used to support training exercises during the Korean and Vietnam wars. Between 1960 and 1980, the extent of the range was either sold or transferred to other non-Federal parties.

Most of the bombing range is now used for cattle grazing or cultivation of small grain crops. The state of Colorado owns a major portion of the former range and leases the property for grazing. The town of Aurora owns several sections of land at the west end of the range, where it has constructed a lake and recreation area. The Plains Conservation Center operates an interpretive center near the National Guard Base. There are a few businesses and residences scattered throughout the former bombing range. Additionally, an Army National Guard Unit uses a small parcel of land owned by the Army. The airfield continues as an active DoD installation known as the Buckley Air National Guard Base. It is jointly owned by the Air Force and the Navy.

Bombing and Gunnery Range: Lowry BGR (Buckley Field), BT #2

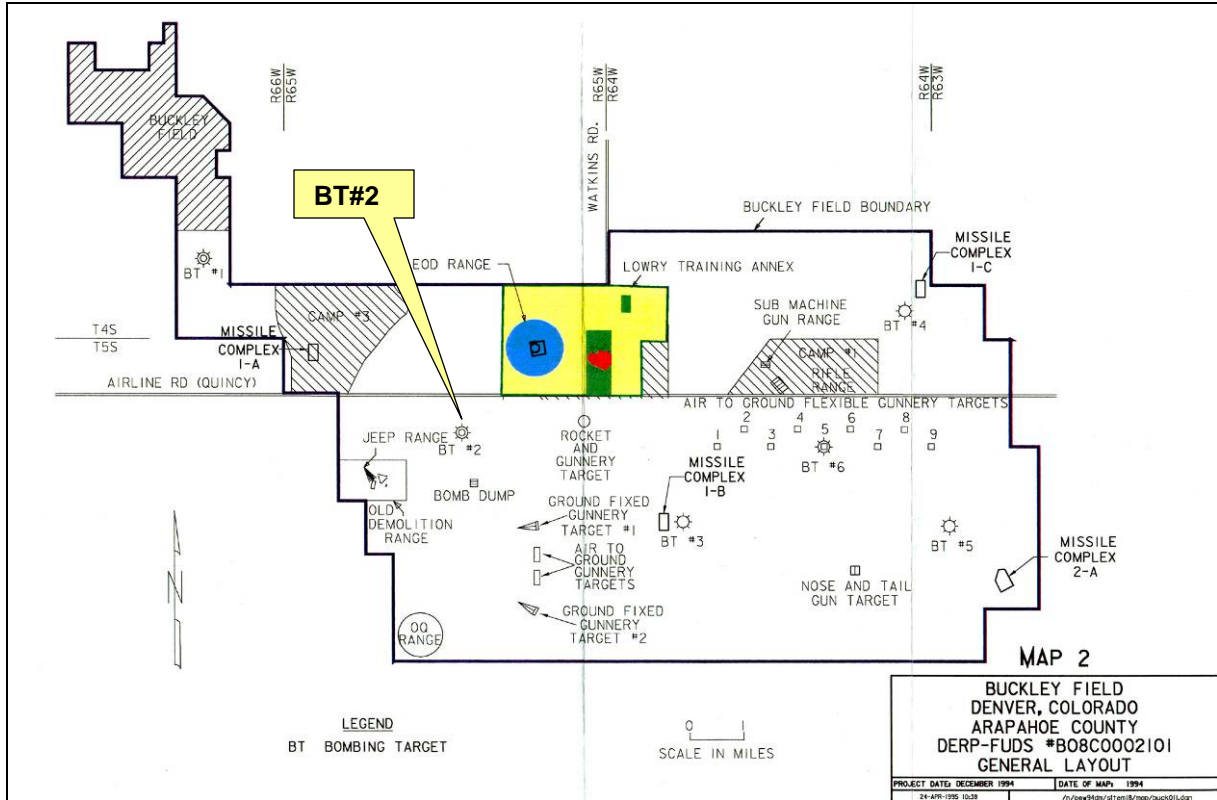

Source: USACE-St. Louis, 1995.

Figure LBGR-1. Former Lowry Bombing and Gunnery Range

Bombing and Gunnery Range: Lowry BGR (Buckley Field), BT #2

Range Area Description

Bombing Target #2

Bombing Target #2 is located about 800 meters (0.5 miles) north of the Aurora Reservoir. Figure LBGR-2 shows Bombing Target #2 and a survey/clearance grid layout. A circle has been drawn to highlight what appears to be a circular trench defining the bombing target. The inner circle measures about 360 m in diameter or about 25 acres. The outer rectangular boundary is about 1000m x 1050m and encompasses about 177 acres. Evidence of ordnance remaining at this target includes three-pound miniature practice bombs (Mk 23), remnants of 100 lb sand-filled practice bombs (M38), practice rockets (SCAR and 2.75-inch), fragments from HE bombs, and numerous bomb craters one meter in diameter. Photos from 1969 reveal more than 100 craters at Bombing Target #2, #4, and #5. During May and June 1945, the photographic school dropped 47 M46 photoflash bombs on Target #2 and the photographic school at Clovis, NM also dropped 42 photoflash bombs on Target #2. There was a concrete structure located at the bull's eye on Bombing Target #2. In November 1946, the Air Corps Assistant Adjutant General requested the establishment of an aerial danger area covering the Bombing and Gunnery Range and two ground danger areas. One of the requested ground danger areas was a one-mile circle around Bombing Target #2. The anticipated activities included dissemination of chemical agents and blinding smokes, dropping of photoflash bombs, dropping of 100 lb practice bombs, and destruction of munitions to include high explosives, miscellaneous ammunitions, and 100 lb bombs.

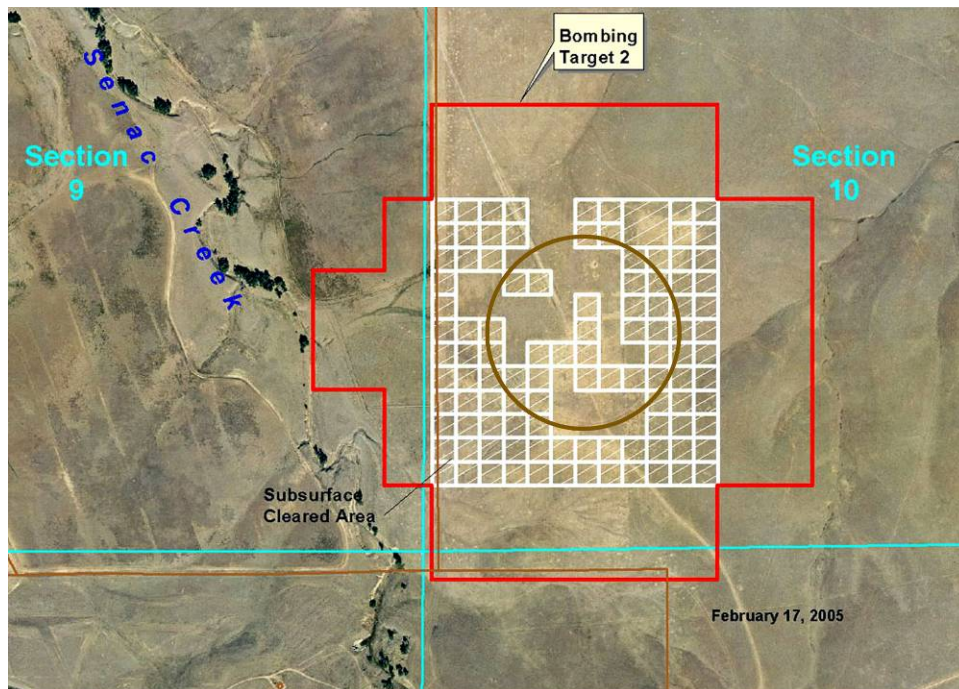

Source: Modified from www.flbgr.org

Figure LBGR-2. Bombing Target #2 and Geophysical Grid Layout

Bombing and Gunnery Range: Lowry BGR (Buckley Field), BT #2

In April 1998, an agreement was reached between U.S. Army Engineering Support Center, Huntsville and the state of Colorado allowing the Naval Research Laboratory (NRL) to commence geophysical survey work at Buckley Bombing Target #2. The NRL, funded by the Environmental Security Technology Certification Program (ESTCP), employed a multi-sensor towed array detection system (MTADS). The MTADS incorporates arrays of cesium vapor, full-field magnetometers (magnetics), and time-domain active pulsed-induction sensors (electrical conductivity) also known as electromagnetics or EM that are towed over the survey site by an all-terrain vehicle.

In 1999, Bombing Target #2 was surveyed using the MTADS magnetometer array (McDonald, et al., 1999). The site that was laid out was 600 x 600 meters (36 hectares) or about 89 acres, centered on the concrete structure at the bull's eye. Because of the amount of surface debris, a site walkover was conducted to remove the metallic scrap to facilitate a DGM survey using MTADS. There were a very large number of buried anomalies at Bombing Target #2. The target density near the bull's eye was very high, with many overlapping target anomaly signatures. Because of the numerous, closely spaced geophysical anomalies, individual targets could not be accurately analyzed within about 75 meters of the bull's eye in a single pass. Twenty five meter transects across the center area were conducted. The Corps of Engineers decided to dig the entire dense area to remove the targets. As part of the MTADS demonstration, one grid (A5) was intrusively investigated to characterize the anomalies detected in the survey. The results of the MTADS survey are summarized below.

A numerical summary of the Buckley Field, Bombing Target #2, including the anomalies detected and number of items found, is presented in Table LBGR-1, and Table LBGR-2 presents the density summary of the same items.

Table LBGR-1. Buckley Field, Bombing Target #2, Summary of Items Found

Sector	Area (acres)	Number of Items Detected/Found					Totals
		Anomalies Only	MEC	MEC Clutter	Non-MEC Clutter	NF/ND	
All Grids less A5 & C5*	84.0	16,500					16500
A5	2.5		113	209	49	26	397

* Grid C5 data missing from data set.

MEC - munitions and explosives of concern; MC - MEC clutter; NF/ND - No Find/No Dig
n/a - not available (not recorded)

Table LBGR-2. Buckley Field, Bombing Target #2, Density Summary

Sector	Area (acres)	Average Item Density (#/acre)					All Types
		Anomalies Only	MEC	MEC Clutter	Non-MEC Clutter	NF/ND	
All Grids less A5 & C5*	84.0	196					196
A5	2.5		46	85	20	11	161

* Grid C5 data missing from data set.

MEC - munitions and explosives of concern; MC - MEC clutter; NF/ND - No Find/No Dig
n/a - not available (not recorded)

Bombing and Gunnery Range: Lowry BGR (Buckley Field), BT #2

The anomaly density is also shown in Figure LBGR-3, where the center of the target that was not surveyed and the missing grid area can be clearly seen. The figure shows a fairly uniform pattern of anomalies surrounding the central target with a slight increase in the number of anomalies along the northern edge of the grid as compared to the southern edge. The reason for this difference is not known, but may be due to a predominant south-north flightline. An anomaly density drop-off from center to outer radius of target is also clearly present.

This anomaly density pattern was analyzed by calculating the average anomaly density in 10m-wide bands moving out from the target center to 400 meters. The result of this analysis is shown as a plot in Figure LBGR-4. A polynomial curve fit is also shown. The curve shows that there is a rapid decrease in the anomaly (and presumably MEC) density as one moves away from the target bull's eye.

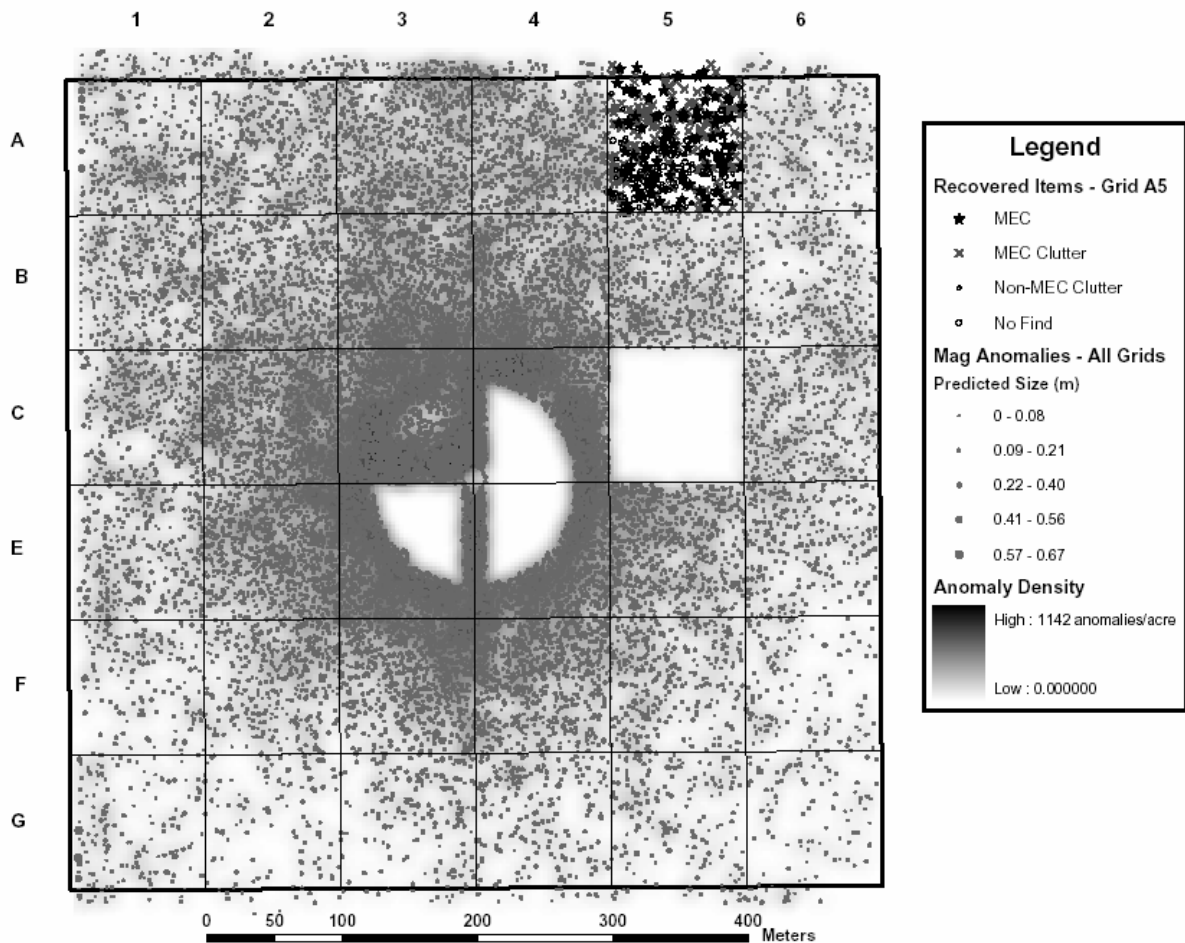

Source: Plot based on data from McDonald et al., 1999.

Figure LBGR-3. Buckley Bombing Target #2, Anomaly Density Distribution

Bombing and Gunnery Range: Lowry BGR (Buckley Field), BT #2

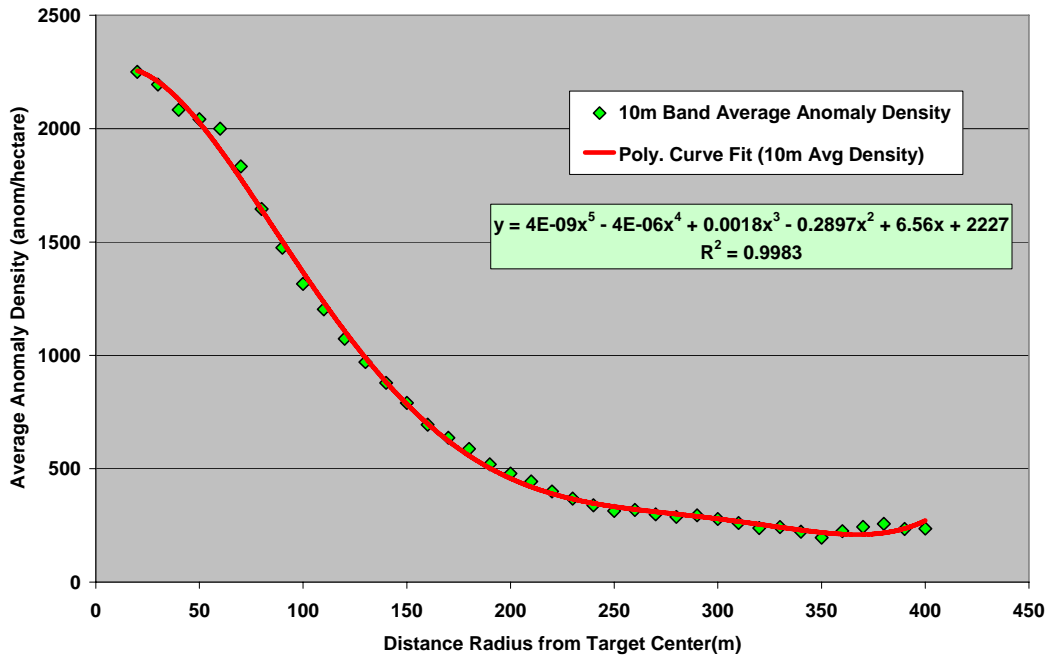

Figure LBGR-4. Average Anomaly Density in 10m Bands from BT#2 Center to 400m Radius

Table LBGR-3 shows the anomaly depth distribution by item type *only* for Grid A5. Table LBGR-4 presents the MEC distribution by type, and Table LBGR-5 is recovery depth of UXO. The grid A5 recovery report did not record recovery depths deeper than 30 centimeters (12 inches), so that information is presented here as >30 centimeters (12-inches).

Table LBGR-3. Bombing Target #2, Anomaly Depth Distribution by Type, Grid A5

Depth (in)	Anomaly Counts					Relative Percentages			
	MEC	MEC Clutter	Non-MEC Clutter	NF/ND	All Types	MEC	MEC Clutter	Non-MEC Clutter	All Types
Surface*		76	12		88		36%	24%	22%
>0 - 6	17	86	30	12	145	15%	41%	61%	37%
>6 - 12	11	6	6	2	25	10%	3%	12%	6%
>12**	85	41	1	12	139	75%	20%	2%	35%
Totals	113	209	49	26	397	100%	100%	100%	100%

MEC - munitions and explosives of concern; MC - MEC clutter; NF/ND - No Find/No Dig

* Most of surface MEC and clutter were removed during surface sweep prior to geophysical survey.

** Recovery team did not record actual depths below 1 ft.

Bombing and Gunnery Range: Lowry BGR (Buckley Field), BT #2

Table LBGR-4. Bombing Target #2, MEC Type Summary

Class	Description				Grid_A5					Surface Sweep - All Grids		
	Category	Type	Purpose	Model Series	MEC	MC	NMC	NF	A5 Totals	MEC	MC	Surface Totals
MEC and MEC Clutter	BOMB	100-LB	PRACTICE	M38	64	9			73	388		388
		3-LB	PRACTICE	MK-23 SERIES	30				30	86		86
		CLUSTER		(UNKNOWN)							26	26
		(UNKNOWN)				3			3			
	BOMBLET	10-LB	INCEN, CLUSTER	M74						1	415	416
		6-LB	INCEN, CLUSTER	AN-M69	6	4			10			
		4-LB	INCEN, CLUSTER	AN-M50 Series						1		1
	FRAG	(UNKNOWN)				192			192		3	3
	FUZE				5	1			6		167	167
	ROCKET	2.5 INCH SCAR			8				8	30		30
MOTOR									39		39	
2.75 INCH		PRACTICE							1		1	
Non-MEC Clutter	SCRAP METAL	BANDING, STRAP										
		WIRE, CABLE, BARB WIRE					4	4				
		(UNKNOWN)					45	45				
	HOT ROCK						15	15				
	NO FIND						11	11				
FLAT METAL	(UNKNOWN)											
Grand Total					113	209	49	26	397	546	611	1157

MEC - munitions and explosives of concern; MC - MEC clutter; NF/ND - No Find/No Dig

Table LBGR-5. Buckley Bombing Target #2, Recovery Depth of UXO

Description				Depth* (in)	Number Recovered at Depth	
Category	Type	Purpose	Model Series		Grid_A5	All Grids - Surface Sweep
BOMB	100-LB	PRACTICE	M38	0		388
				6	1	
				12	1	
				>12	62	
	3-LB	PRACTICE	MK-23 SERIES	0		86
				3		
				4		
				5		
				6		
				8		
				9		
				10		
				12		
				>12		
ROCKET	2.5 INCH SCAR			0		30
				6	1	
				10	1	
				>12		
				6		
		MOTOR		0		39
	2.75 INCH	PRACTICE		0		1
BOMBLET	10-LB	INCEN, CLUSTER	M74	0		1
	6-LB	INCEN, CLUSTER	AN-M69	3	1	
				>12	5	
	4-LB	INCEN, CLUSTER	AN-M50 Series	0		1
FUZE	BOMB		M100 Series	2	1	
				>12	4	
Grand Total					113	546

* Recovery team did not record actual depths below 1 ft.

Bombing and Gunnery Range: Lowry BGR (Buckley Field), BT #2

Bombing and Gunnery Range: Conway BGR, SC, Range III

Range Overview

General Facility Description:

The former Conway BGR is a former U.S. Army installation located northwest of Myrtle Beach, South Carolina (Figure CBGR-1.). The former Conway BGR contained Ranges II, III, IV, VII, XX, a moving target range, two turret ranges, a machine gun range, and a rifle range when it was part of the Myrtle Beach Army Air Field from 1942 to 1948. Figure CBGR-1 shows the locations of the ranges and the designated areas located within the former Conway BGR. Figure CBGR-2 show the historic layout of the ranges. These ranges were used for a variety of bombing and air to ground gunnery training purposes during World War II (primarily 1942-1946). Table CBGR-1 lists typical aircraft using the ranges during WWII. Today, most of the former Conway BGR is owned by private entities and is used mainly for timber harvesting, agricultural, residential, and recreational purposes.

Location: Conway, SC

Size: 55,854 acres

Range Types:

Precision Bombing (Live and Practice) using Incendiary and General Purpose Bombs at medium to high altitudes, Dive bombing, Skip bombing, Air-to-Ground Rockets, Air-to-Ground Gunnery, Strafing and Small Arms Moving Gun Targets, Moving Target Range; Position Firing Course; Machine Gun Range, Rifle Range; Turret Ranges.

Typical Ordnance Types:

4-lb Incendiary Bomb (AN-M54; AN-M50A2)
6-lb Incendiary Bomb (M69)
20-lb Practice Fragment Bomb (AN-M41A1; AN-M48)
100-lb General Purpose Bomb and Practice Bomb (M38A2)
250-lb. HE Bomb (M57-Old Style)
2.25-inch Sub-Caliber Aircraft Rocket (SCAR)
5-in Practice High-Velocity Aircraft Rocket (HVAR)
1.1-in AA Projectile (25 MM)
.50-caliber Projectiles

Geology/Soils:

The shallow soils are typically poorly drained loamy sands or clayey sands. The water table is close to the land surface as evidenced by the swampy areas.

Climate:

Climate is semi-tropical with little or no freezing. Precipitation is about 132 centimeters (52 inches) per year.

Terrain:

The site lies within the Lower Atlantic Coastal Plain physiographic province and is characterized by nearly flat terrain with swamps. Elevations range from near sea level to about 12 meters (40 feet) above sea level.

Vegetation/Land Cover:

Much of the land is covered by pine forests or grass; swampy areas are also present.

Bombing and Gunnery Range: Conway BGR, SC, Range III

Site-Specific References – Conway Bombing and Gunnery Range

Parsons, 2003a. Final Time Critical Removal Action Report, Conway Bombing and Gunnery Range, Conway, South Carolina. Prepared for U.S. Army Engineering Support Center, Huntsville, Alabama, February 2003

Parsons, 2003b. Final Engineering Evaluation and Cost Analysis Report for the Former Conway Bombing and Gunnery Range, Conway, South Carolina. Prepared for U.S. Army Engineering Support Center, Huntsville, Alabama, September 2003

USACE-Rock Island, 1995a. Archive Search Report Findings for the Conway Bombing and Gunnery Range, Horry County, South Carolina. U.S. Army Corps of Engineers, Rock Island District, September 1995

Bombing and Gunnery Range: Conway BGR, SC, Range III

General Site Description

Conway Bombing and Gunnery Range was created in early 1942 as part of the larger Myrtle Beach Army Air Field (AAF) composed of about 100,000 acres. Its location is shown in Figure CBGR-1. The AAF consisted of a cantonment area in Myrtle Beach, air to ground gunnery ranges in the Myrtle Beach area, a bombing and gunnery range in the Conway area (Conway BGR), a bombing and gunnery range in the Georgetown area and crash and target boats at Murrells Inlet.

During WWII, Myrtle Beach AAF conducted flight, air to ground gunnery and bombing training for Army Air Corps and Air Force pilots. The principal plane used at MBAAF was the Douglas A-26 Invader. The bombers and fighters used at Myrtle Beach AAF during WWII and their typical armament are shown in Table CBGR-1. Several other airfields and bases in South Carolina utilized Conway BGR as well.

The CBGR contained several specific ranges including: Ranges II, III, IV, VII, XX, a moving target range, a turret range, a machine gun range and a rifle range. The historical layout of the CBGR is shown in Figure CBGR-2. These ranges were used for a variety of bombing and air to ground gunnery purposes throughout WWII. A list of how the ranges were used is shown in Table CBGR-2. Available documentation does not address the use of the turret range, machine gun range or the rifle range. Use of the turret range is assumed to be limited to small arms air to ground gunnery from the turrets of bombers to ground targets. Use of the machine gun range is assumed to be firing of bomber turrets and machine guns in a ground mounted mode. The rifle range was most likely used for basic rifle marksmanship.

Bombing and aerial gunnery missions took place frequently at Myrtle Beach AAF. Squadrons from airfields and bases throughout South Carolina also utilized the ranges. Heavy use of CBGR continued until early 1946 when the AAF was converted from wartime to peacetime training. During peacetime training, use of CBGR diminished greatly.

In 1948, CBGR was declared surplus to government needs and the land was sold or returned to its pre-war owners, primarily International Paper Company. Today, CBGR is owned by several private and some public entities. The two largest land owners are the International Paper Realty Corporation and the South Carolina Wildlife and Marine Resources Department. A large percentage of the land is currently used for timber harvest and a wildlife refuge. Residential and limited commercial areas exist primarily along the borders of the site.

Bombing and Gunnery Range: Conway BGR, SC, Range III

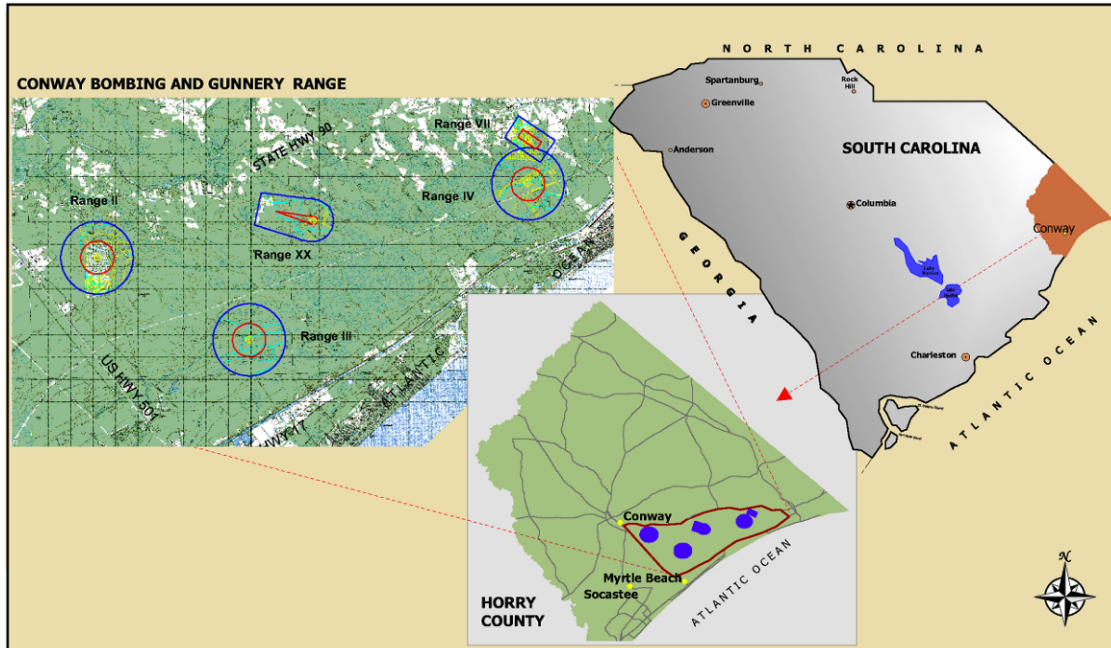

Source: Parsons, 2003b

Figure CBGR-1. Conway Bombing and Gunnery Range

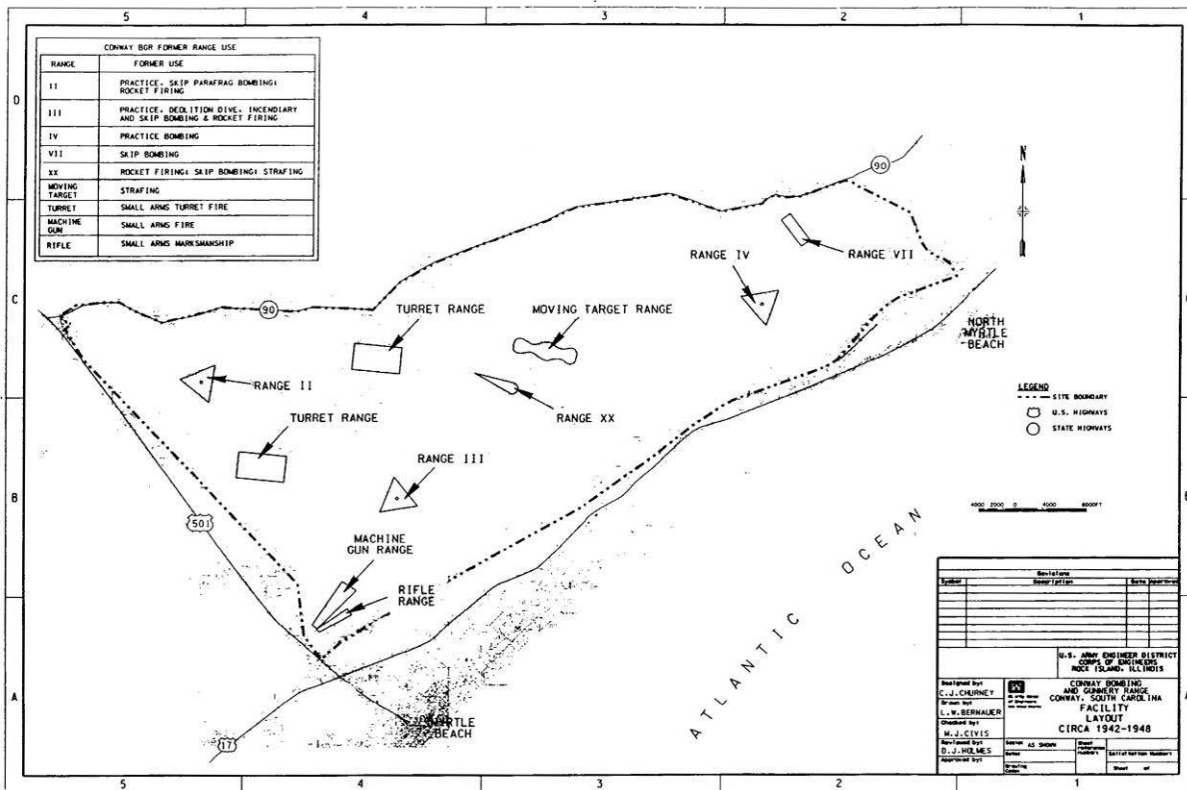

USACE-Rock Island, 1995a

Figure CBGR-2. Conway BGR, Facility Layout, 1942 – 1948

Bombing and Gunnery Range: Conway BGR, SC, Range III

Table CBGR-1. Aircraft Using Conway BGR During WWII

Aircraft	Tactical Weapons	Practice Munitions
Douglas A-26 Invader	Up to (10) .50 cal bomber machine guns 4,000 lb internal bomb load 2,000 lb underwing bomb load	.50 cal ball 3, 20, 23 and 100 lb practice bombs
North American B-25 Mitchell	Up to (14) .50 cal machine guns 75mm gun 2,000 lb torpedo 4,000 lb internal bomb load	.50 cal ball 75mm rounds 3, 20, 23 and 100 lb practice bombs
North American P-51 Mustang	Six .50 cal machine guns Two 500 lb or 1,000 lb bombs	.50 cal ball 3, 20, 23 and 100 lb practice bombs
Northrup P-61 Black Widow	Four 20 mm cannon Up to 6,400 lb underwing bomb load	20 mm ball 3, 20, 23 and 100 lb practice bombs
Republic P-47 Thunderbolt	Eight .50 cal machine guns Up to 2,500 lb of external bombs or rockets	.50 cal ball 3, 20, 23 and 100 lb practice bombs 2.25, 4.5 and 5 inch practice rockets

Table CBGR-2. Historical Range Uses - Conway Bombing and Gunnery Range

Range	Range Type/ General Use
II	Practice Bombing and Skip Bombing from high and medium altitudes plus rocket firing
III	Practice Bombing with 100 lb bombs, skip bombing, and the firing of 2.25" rockets. Also, demolition bombing, dive bombing, strafing, and incendiary bombing from high and medium altitudes and high velocity aerial rockets (HVAR).
IV	Practice bombing from medium altitudes
VII	Skip Bombing
XX	Rocket firing, strafing, and skip bombing. Also used as a position firing course and for air to ground gunnery practice
Moving Target	Moving gun targets and strafing

Table CBGR-3. Range Sizes

Range	Range Zones	Approx. Size (acres)	Diameter (meters)
II	Impact Zone	425	1480
	Safety Zone ¹	1580	
	Combined	2005	3214
III	Impact Zone	425	1480
	Safety Zone ¹	1580	
	Combined	2005	3214
IV	Impact Zone	425	1480
	Safety Zone ¹	1580	
	Combined	2005	3214
VII	Impact Zone	100	
	Safety Zone	460	
	Combined	560	
XX	Impact Zone	80	
	Safety Zone	1290	
	Combined	1370	
Small Arms		2576	
Remaining Area		45,506	
Total		55,854	

1 - Safety buffer zone approximately 867m around impact zone.

Bombing and Gunnery Range: Conway BGR, SC, Range III

Bombing and Gunnery Range: Conway BGR, SC, Range III

Range Area Description

General

According to the archive search records the entire site was cleared in 1995 but there is no record of what was removed, the density, or other details about the clearance. In 1999-2000 an EE/CA was performed on portions of five ranges (Ranges: II, III, IV, VII, and XX). The EE/CA used two geophysical instruments, an EM 61 and a Schonstedt Magnetometer. The magnetometer was used to screen locations for stakes and other intrusive activities. Digital geophysics was used on selected grids and transects followed by intrusive investigation of selected anomalies. Table CBGR-4 presents the amount of area surveyed in the 2000 EECA. Also in 2000, a separate time critical removal action (TCRA) was performed on Range III using an MTADS and a G858 magnetometer.

The range wide removal action used a combination of DGM and “Mag and Dig”. A total of 56,420 pounds of scrap metal and 46,300 kilograms (102,000 pounds) of hazardous materials were removed during the range wide EE/CA. The depths at which UXO items were recovered varied but most were found at 0.6 to 1.2 meters (2–4 feet) below land surface. Table CBGR-5 list the types and numbers of MEC item found. The most common type of UXO recovered and destroyed were 4-lb incendiary bombs. The largest and most hazardous UXO encountered and recovered was an M57 250-lb live HE bomb. Most MEC was found at depths of less than 1.2 meters (4 feet); however, the deepest item recovered was a 5-inch HVAR warhead with an attached rocket motor at a depth of 8 meters (26 feet).

Information on the responses taken at the ranges is presented below followed by more specific information for Range III within the Conway BGR.

Table CGBA-4. Areas Investigated During 1999-2000 EE/CA

Area ID	Approx Size (acres)	Area for Survey (acres)(1)	Grids(2) Investigated	Transect Length Investigated(3) (feet)	Acreage Investigated (acres)	Percentage Investigated
Area A (Range II – Impact Zone)	425	342	3	0	0.17	0.05
Area A-1 (Range II – Safety Zone)	1,580	1025	7	0	0.4	0.04
Area B (Range III – Impact Zone)	425	189	49	2,309	2.97	1.57
Area B-1 (Range III – Safety Zone)	1,580	550	93	5,924	5.75	1.05
Area C (Range IV – Impact Zone)	425	84	13	0	0.75	0.89
Area C-1						
Area C-1 (Range IV – Safety Zone)	1,580	237	63	2,489	3.79	1.6
Area D (Range VII – Impact Zone)	100	34	6	0	0.34	1
Area D-1 (Range VII – Safety Zone)	460	149	20	2,579	1.33	0.89
Area E (Range XX – Impact Zone)	80	21	1	0	0.06	0.29
Area E-1 (Range XX – Safety Zone)	1,290	592	5	0	0.29	0.05
Total	7,945	3,222	260	13,301	15.85	0.49

Notes:

1 – Area available for survey is calculated by using the following equation:

Total Size of the Area minus (Right of Entry Not Obtained in the Area plus the Wetland Area in the Right of Entry Obtained Area)

2 – Each grid is approximately 50 feet x 50 feet

3 – Each transect is 3 feet wide

4 – Percentage investigated is based on Available Area for Survey

Bombing and Gunnery Range: Conway BGR, SC, Range III

Table CGBA-5. EE/CA Items Found Summary

Range	Area ID	Total Anomalies Identified	Items Found								Percentage False Positive
			MEC	Intact MEC	MEC Clutter	Non-MEC Clutter	Other (O)	Underwater (W)	Not Dug (ND)	Nothing Found (N)	
II	A	6			5	1					
	A-1	12			1	6				4	33%
III	B (Grids)	304	2	3	161	27		5	8	90	30%
	B (Transects)	39			16	1				22	56%
	B-1 (Grids)	111			18	22				71	64%
	B-1 (Transects)	74			2	2				70	95%
IV	C (Grids)	35			22	6				7	20%
	C-1 (Grids)	123			20	28				75	61%
	C-1 (Transects)	38			16	16				6	16%
VII	D (Grids)	9				1				8	89%
	D-1 (Grids)	22				12				10	45%
	D-1 (Transects)	22				15	1			6	27%
XX	E										N/A
	E-1										N/A
Totals		795	2	3	261	137	1	5	8	369	46%

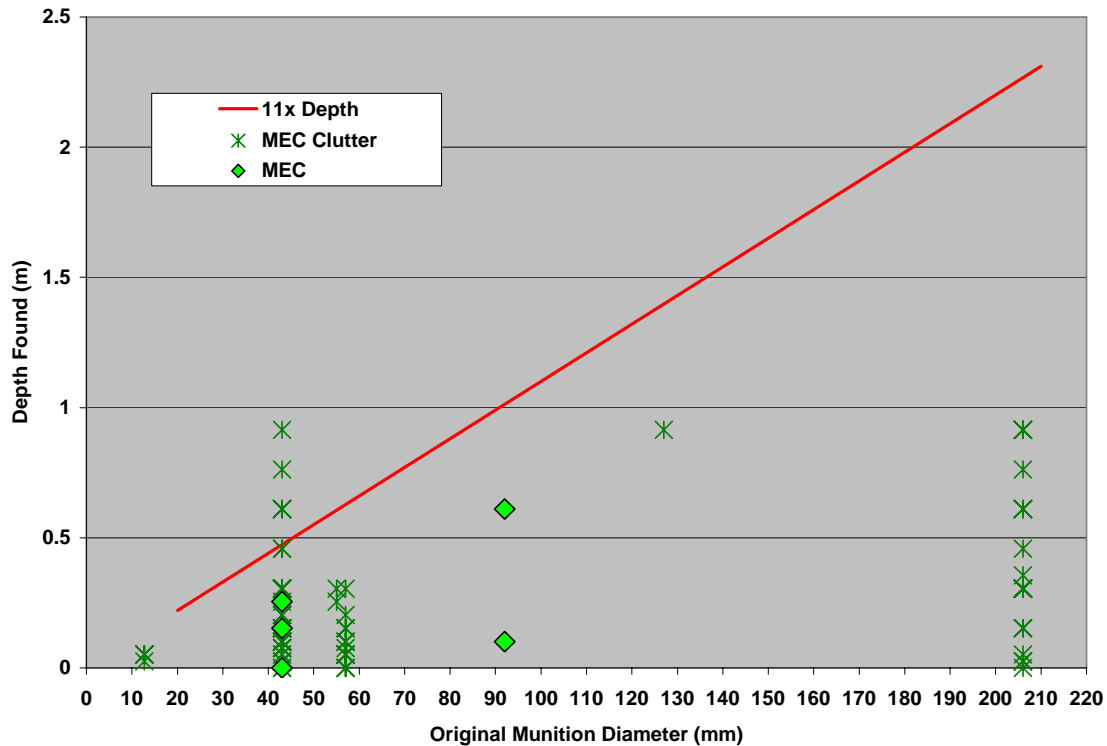

Figure CBGR-3. MEC and Clutter Items, Diameter versus Depth Conway BGR, Range III (Center Target Area)

Bombing and Gunnery Range: Conway BGR, SC, Range III

Bombing Range III

A general description of the range can be found in the earlier overall description of the Conway BGR. Bombing Range III is located in the south central part of the Conway BGR. Range III had a circular target impact area 1,480 meters in diameter (425 acres) surrounded by a circular safety zone that extended out from the impact area 867 meters and encompassed about 1,580 acres for a total range size of about 2,005 acres or a circular area 3,214 meters in diameter (Figure CBGR-3). The range was used for precision bombing using live and practice bombs at high and medium altitudes, skip and demolition bombing, dive bombing, air-to-ground rockets, strafing, and air-to-ground gunnery training. Typical munitions used on this range included:

- 100 lb Practice Bomb
- 2.25” Rocket
- 4-lb Incendiary Bomb (AN-M54; M50)
- 5-in Practice HVAR Warhead
- 6-lb Incendiary Bomb (M69)
- 20-lb Practice Fragment Bomb (AN-M41A1; M48)
- 100-lb Practice Bomb (M38A2)
- 250-lb. HE Bomb (M57-Old Style)
- 1.1-in AA Projectile (25 MM)
- 5-in Practice HVAR Warhead

Within the impact area a lake has recently been constructed. Much of the lake bed was cleared using various methods and MEC was removed using different approaches (Figure CBGR-5). The various geophysical methods used and the types of removal actions undertaken are detailed in Tables CBGR-6 and CBGR-7 and shown in Figure CBGR-6. A TCRA was undertaken in a 40 acre area and approximately 80,000 anomalies were identified and nearly 2,160 UXO items were recovered and destroyed (Table CBGR-8). An “enormous amount” of metal scrap was also removed. The lake now occupies a large portion of the impact area.

Bombing and Gunnery Range: Conway BGR, SC, Range III

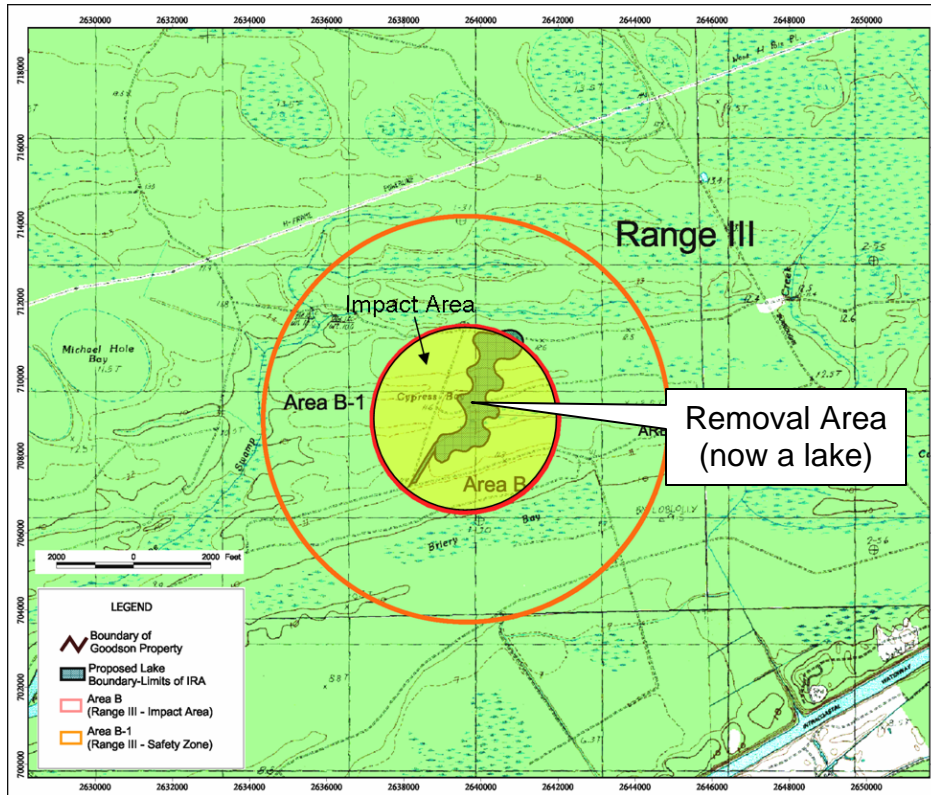

Figure CBGR-4. Bombing Range III and Removal Action Area

Table CBGR-6. Digital Geophysical Mapping Systems Used in the Range III Removal Action, Conway BGR

Dates of Operation	Instrument System	Area Covered (acres)	Notes
Phase I: 06/05/2000 to 06/09/2000	MTADS with G-858 Base Station	34	
	G-858 (QC on MTADS)	2.5	(11) 100'x100' grids
Phase II: 08/29/2000 to 09/01/2000	MTADS with G-858 Base Station	7.6	Some overlap with Phase I.
	G-858 (QC on MTADS)	0.9	(2) 100'x100' grids
12/2000 to 09/2001	G-858 with G-856 Base Station	17.1	Complete coverage of selected grids mostly in the central and southern lakebed area. Used to support 'Mag and Dig' operations.

Bombing and Gunnery Range: Conway BGR, SC, Range III

Table CBGR-7. Clearance Methods Used for the TCRA at Range III, Conway BGR

Response/Removal Technique	Number of Grids	Area (acres)
'Mag and Dig' alone	86	13.7
Excavation of G-858 anomalies	28	5.1
'Mag and Dig' followed by G-858 mapping	52	10.6
Excavation of MTADS anomalies	1	<0.1
Excavation of MTADS anomalies followed by 'Mag and Dig.'	42	7.3
Combination of 'Mag and Dig', G-858 and MTADS	6	1.4
No removal Land excavated without UXO clearance	18	2.4
Total Cleared	233	40.5
Remaining to be cleared	18	3.6
Total	251	44.1

Note: Many of the grids at the edge of the lakebed are partial grids

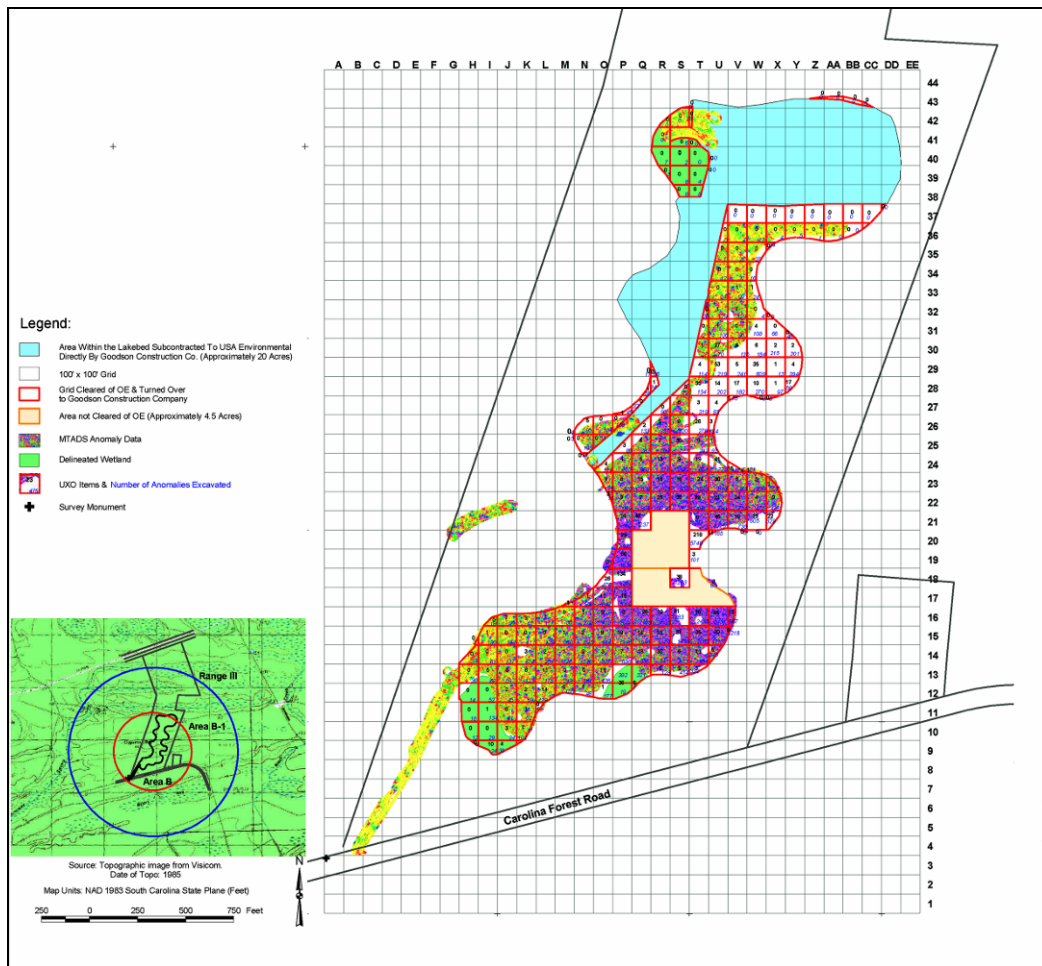

Figure CBGR-5. Detail of Portion of Impact Area Showing the MTADS Anomaly Data Generated during the TCRA, Range III, Conway BGR

Bombing and Gunnery Range: Conway BGR, SC, Range III

**Table CBGR-8. Summary of Items Found during 2000 EE/CA,
Conway BGR, Bombing Range III,**

MEC Items Found		Number of Items	Total
4-lb Incendiary Bomb (AN-M54; M50)			2012
	Bomb	1512	
	Burster	35	
	Burster end	366	
	Fuze	36	
	Fuze end	63	
6-lb Incendiary Bomb (AN-M41A1; M48)			5
	Bomb	3	
	Components	2	
20-lb Practice Bomb (M38A2)			37
	Bomb	33	
	Fuze	4	
100-lb Practice Bomb (M38A2)			41
	Black powder charge	2	
	Flash tube	9	
	Fuze igniter tube	2	
	Fuze	12	
	Fuze component	14	
	Fuze with live shell	2	
			41
250-lb HE Bomb (M57, old style)			1
1.1-inch AA projectile (25mm)			3
5-inch Practice HVAR Warhead			49
Miscellaneous			9
	Fuze components	3	
	28 gauge shotgun shell primer	1	
	M16 Fuze burster	2	
	M16 Igniter	1	
	M16 WP igniter	1	
	Fuze M38/28 GA shotshell	1	

Appendix D—Standard Range Designs

Selected pages extracted from:

USACE-St. Louis, 2002, “Army Range Inventory, Data Collectors Instructions - Appendix F, Range Information, Description, Cells,” US Army Corps Of Engineers, St. Louis District, April 18, 2002.

(Small Arms ranges not included)

Standard Range Designs

Standard Range Designs

RANGE INFORMATION / DESCRIPTIONS / CELLS

The *Range cells* in this document represent a general range layout and were constructed using historical regulations, manuals, and documents. These cells do not account for the actual terrain, conditions and installation restrictions or boundaries. Consideration should be given to utilizing existing fans drawn on historical maps. This does not mean that every range fan on historical maps is a true representation, but it very well could be. Each map should be analyzed to determine its accuracy; and it may be best to rely on that accuracy. Situations may require altering the range cell to best represent the historical range. Below are some examples:

Based on historical research, 155mm rounds were fired with reduced propellant charges on the Artillery Range at the FUDS site, Fort Custer. The maximum range of a 155mm with a full charge is approximately 17,400 yards. A mandatory 1,000-yard buffer zone is added to that distance. If this maximum range were used, the range fan (cell) would extend approximately 11,000 yards beyond the installation boundary into the town limits. In addition to reducing charges to shorten the downrange distance, gun crews can also restrict the gun's elevation. Range personnel on the installation would have calculated distances based on the amount of propellant charge and gun elevation. Unfortunately, this detailed information is normally not available in historical documentation found during research. Therefore, the historical range map has to be analyzed for accuracy.

The historical range map of Fort Custer delineates the artillery range, as well as others. All fans on this map appear to be proportioned, and closely represent correct angles and distances. It is believed this map was done with a high degree of accuracy; and therefore, the range fan on the historical range map is used instead of the standard range cell, which would grossly over-estimate the acreage for this range.

Range fans in historical manuals represent the general range layout. An actual range can be constructed only after a field investigation. The engineer tasked to build a range would be required to consider the local conditions prior to establishing accurate safety fans. Right and left firing limits were required and set on Artillery Ranges, Anti-Aircraft Ranges, Combat Ranges, Field Fire Ranges, etc. Since there are no set standards for these limits, range personnel would have established them based on munitions, terrain, boundaries, and adjacent ranges. A true safety fan could be calculated once these limits were set.

Unfortunately, this data is available in only a few situations. Therefore, based on information acquired during historical research (maps, aerial photos, documentation, etc.), assumptions made, and a calculated (educated) guess, the typical range layout (or range cell) would be positioned.

For example: Documents included in the ASR for Spencer Mountain Rifle Range, state that the range was positioned at the base of the mountain in order to reduce the danger area. The only map found shows a rectangular box for the range. If the typical range cell were automatically positioned at the location of this box, without accounting for the terrain, the acreage would be grossly over-estimated. In addition to the terrain reducing the safety fan, and thus the acreage, was the actual size of the range. The range cell represents a range designed for 50 firing

Standard Range Designs

positions, which calculates to a width of 400 yards (1200 feet). However, during the site inspection, the actual width of the range was determined to be 150 feet. Therefore, after the above analysis, the acreage for Spencer Mountain Rifle Range was reduced from 1259 acres to 72 acres.

As indicated, there are many variables to account for when developing range boundaries, and it is unlikely that all of the data used when the range was originally laid out will be available. Therefore, utilize the historical data found during research (maps, aerial photos, documentation) to represent the range as accurately as possible. In most cases, however, these range cells can be used as is.

The following is a list of Ranges by Historic Range Type, the standard acreage of the range, and the page numbers for the range description and image of the range cell. (*Small Arms ranges have been omitted.*)

Standard Range Designs

Range Name	Cell Name	Std Acreage
Multiple/Combined Use		
Ground Towed Target	GRTTG	6225
Artillery		
Anti-Aircraft (Up To 4.7-INCH), Aka: AA Range, AAA Range	AA4.7	TBD
Artillery	ARTILL	TBD
Recoilless Rifle, Known Distance, aka: Recoilless Rifle, Known Distance; Recoilless Rifle, KD; Reckless Rifle, KD	RERIKD	8669
Tank (Main Gun) -- No Cell, Refer To Artillery Range	NA	TBD
Mortar		
Mortar	MORTAR	1866
Mortar, 4.2-Inch Sub-Caliber	MORT42	3.5
Hand Grenade		
Grenade Court (Practice), aka: Practice Grenade Range	GRENP	2
Grenade Court (Live), aka: Live Grenade Range	HGRENA	25
Grenade Assault Course	AGREN	48
Rifle Grenade / Anti-Tank Rocket		
Rifle Grenade (Practice)	RGREN	3
40mm Grenade Launcher M79 & M203 (HE)	RGREN	40
40mm Grenade Launcher M79 & M203 (Practice)	RGREN	11
Rocket, 2.36-Inch (Moving Targets)	RRMT	209
Rocket, 2.36-Inch (Stationary Targets)	ROCKET	179
Rocket, 3.5-Inch (Moving Targets)	ROCKMT	497
Rocket, 3.5-Inch (Stationary Targets)	ROCKST	410
Air-To-Ground		
Rocket, Air-To-Ground	RKTA2G	8202
Air-To-Ground Gunnery	A2GGUN	640
Bombing		
Bombing Target (Live), aka: Precision Bombing Target; Bombing Range	BOMB	649
Bombing Target (Practice), aka: Precision Bombing Target; Practice Bombing Target	BOMB	649
Demonstration Bombing Target (Practice)	DEMBMB	72
Air-To-Air		
Air-To-Air	NA	TBD
Training Area / Maneuver Area		
Combat In Cities Course, Single Approach, aka: Village; Jungle Village; Mock City; MOUT Site	CCITY	1702
Combat In Cities Course, 3-Way Approach, aka: See Above	CCI3W	7501
Cave	NA	TBD
Pill Box	NA	TBD
Ob/Od		
Burn Area		TBD
Range Used For Destruction Of Ammunition, Demonstrations, And Explosive Ordnance Disposal (EOD)		TBD

Standard Range Designs

Standard Range Designs

GROUND TOWED TARGET

Range Type: Multiple/Combined Use

Cell Name(s): GRTTG

Firing at a distance of up to 900 yards at targets on sleds or cars towed by motor vehicles is permitted on this range. Pulleys may be set at desired locations to accomplish changes in the direction of the target. More than one car or sled may be used at one time. Right and left limits of fire would have been established based on existing conditions. As shown in the cell, the suggested depth of the range is 1,000 yards and the firing line is 200 yards wide. A danger area would have been established based on the right and left firing limits and the width of the firing line. A 600-yard buffer is added to each side of the range and a 1,000-yard buffer is added downrange beyond the maximum range of the weapon used. An arbitrary safety fan angle of 30°, which is based on assumed right and left firing limits, the angle of fire, and ricochet zones, is used for this range cell. This range is designed to accommodate 37mm tank guns, 37mm sub-caliber weapons, rifle grenades and antitank rockets.

Note: Rockets and Rifle Grenades have a limited effective range so targets would be engaged from 100 to 300 yards, and from 25 yards to 125 yards; respectively.

<u>Ammunition (probable)</u>	<u>Max Range (yards)</u>
37mm AP	4,950
2.36" Rocket (Practice)	700
Rifle Grenade (Practice)	< 400

Data sheet(s):

CTT01	Small arms, General
CTT10	M7A1, Practice Rocket, 2.36"
	M7A3, Practice Rocket, 2.36"
	M11A2, Practice Rifle Grenade
CTT13	37mm, APC, M59

Reference(s): *AR 750-10, Range Regulations for Firing Ammunition in Time of Peace*, May 1939 – January 1944; *TM 9-855, Targets, Target Material, and Training Course Lay-outs*, August 1944 & November 1951; *FM 23-30, Hand and Rifle Grenades, Rocket, AT, HE, 2.36-inch*, February 1944

Standard Range Designs

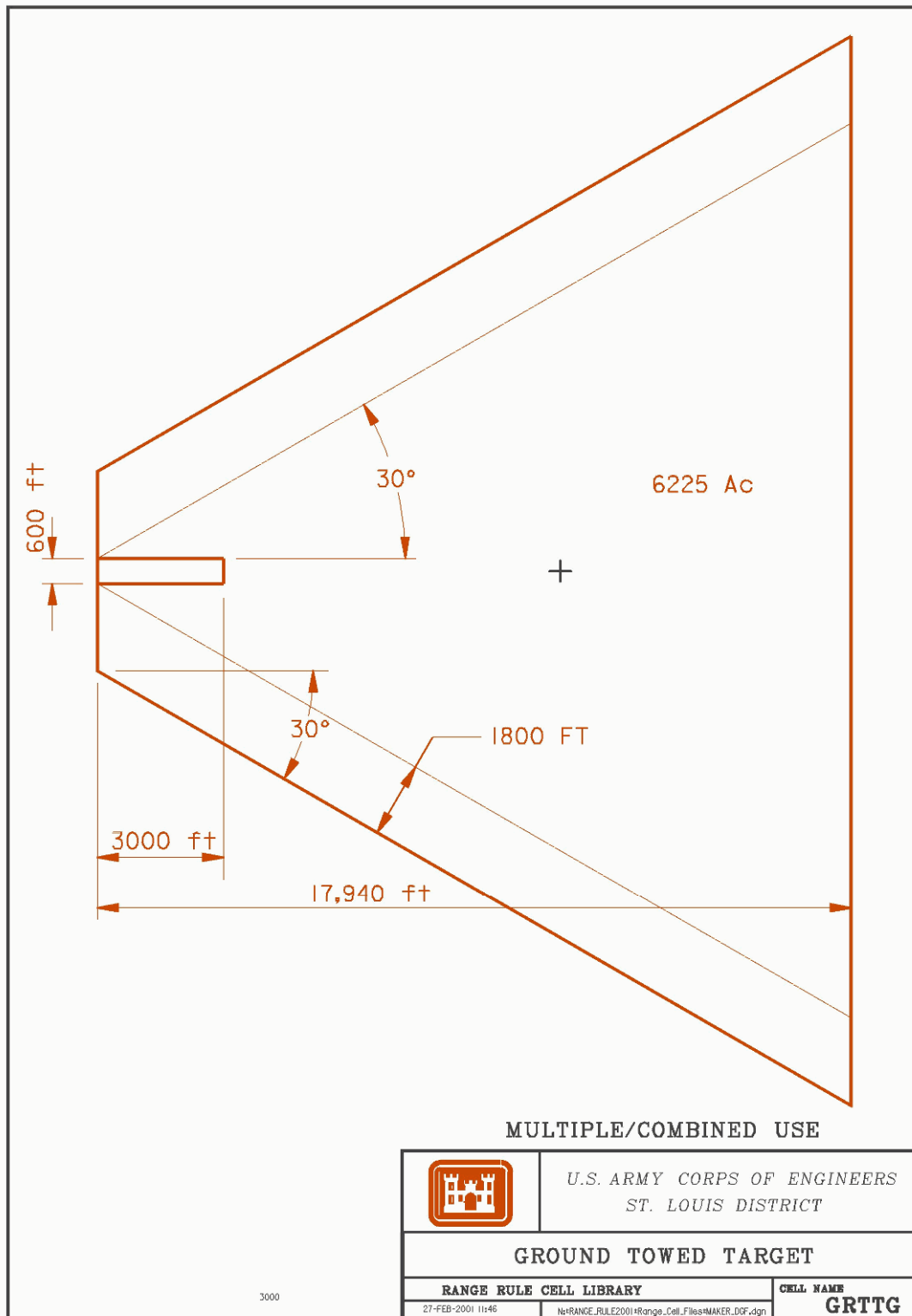

Standard Range Designs

ANTI-AIRCRAFT, up to 4.7-inch (aka: AA Range, AAA Range)

Range Type: Artillery

Cell Name(s): AA4.7

Regardless of the elevation at which the firing is conducted, the maximum ground impact range of the piece will always be considered when determining the safe field of fire of antiaircraft cannon of any caliber. In addition to the limits of fire, the danger area includes areas 1,000 yards wide, which flank both the right and left limits of fire and extends 1,000 yards beyond the maximum ground impact range.

The field of fire would have been locally determined. However, arbitrary right and left limits of 20° have been used for the range cell. The 3" A.P., M62, which has a maximum range of 15,300 yards, was selected for calculating the down-range limit for the cell.

The down range distance needs to be calculated if munitions used are suspected to be larger than 3-inch.

<u>Ammunition (probable)</u>	<u>Max Range (yards)</u>	<u>Muzzle Velocity (fps)</u>
.30 caliber	3,450	2,700
.50 caliber	7,500	2,545
20mm, HE, HEI, AP	6,500	2,850
37mm, HE; Practice; AP; APC	8,875	2,600
40mm, HE; AP	10,850	2,870
75mm, Shrapnel	10,450	1,825
3-inch, HE; Shrapnel, AP	15,300	2,800
90mm, HE	18,000	2,700
105mm, HE; Practice	20,000	2,800
4.7-inch, HE	28,250	3,100

Standard Range Designs

Data sheet(s):

CTT01	Small arms, General
CTT11	20mm, Ball, M55A1
CTT13	37mm, AP, M74
	37mm, APC, M59
	37mm, APC, M54
	37mm, HE, MkII
	40mm, AP-T, M81
	40mm, HE & HEI, MkII
	75mm, AP, M72
	75mm, HE M48
	75mm, Shrapnel, MKI
	90mm, APC, M82
	90mm, AP, M77
	105mm AA (currently, no data sheet available)
	4.7-inch, HE, M73
CTT15	37mm, Practice, M55A1
	90mm, Practice, M58

Reference(s): *AR 750-10, Range Regulations for Firing Ammunition in Time of Peace*, May 1939 – January 1944; *TM 9-855, Targets, Target Material, and Training Course Lay-outs*, August 1944 & November 1951

Standard Range Designs

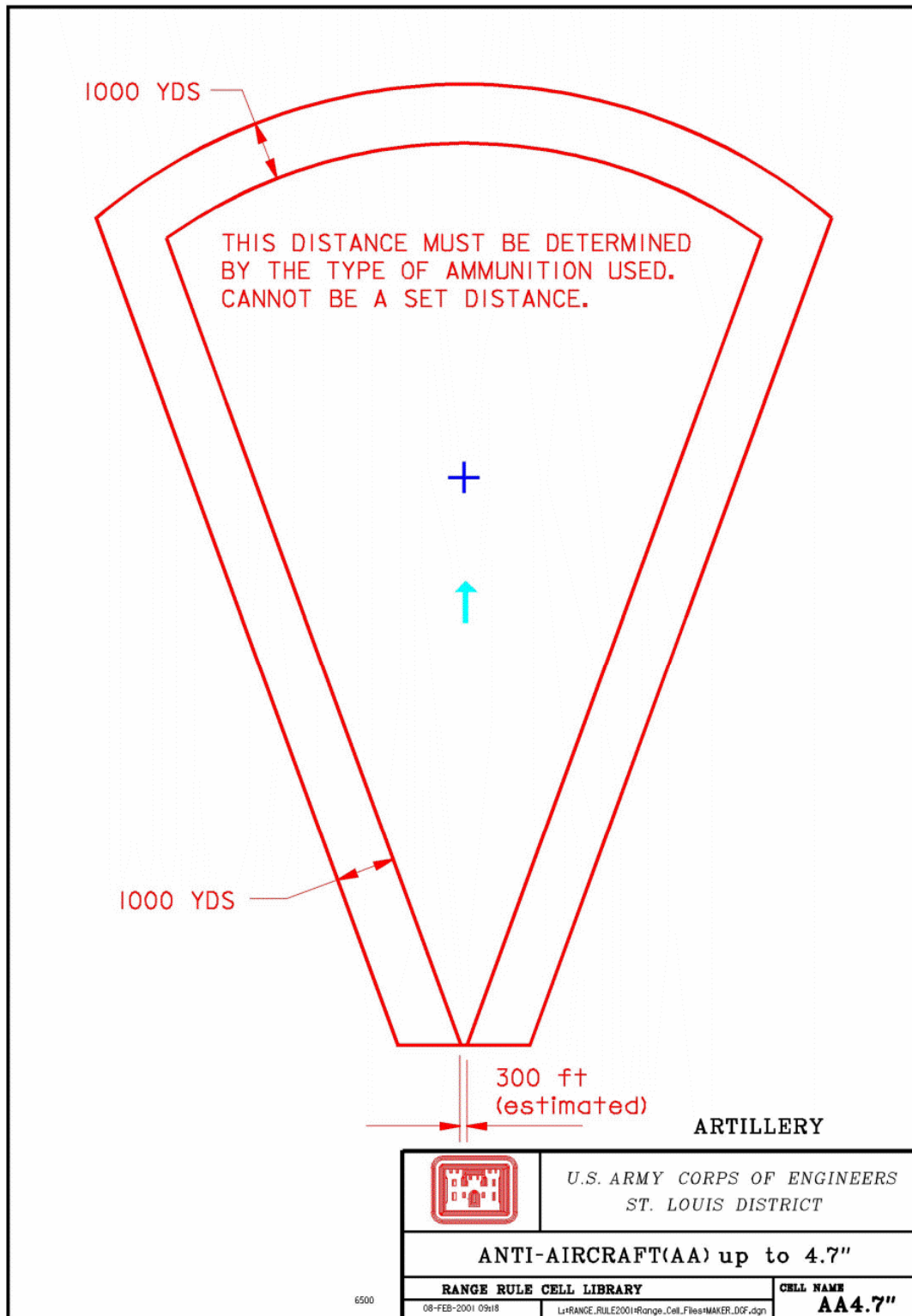

Standard Range Designs

Standard Range Designs

ARTILLERY

Range Type: Artillery

Cell Name(s): ARTILL

The danger area for an artillery range, which is based on the caliber of ammunition, consists of the impact area and danger areas to the rear, sides, and fronts. Without information concerning elevation and charge used, the impact area needs to extend out to the maximum range of the weapons. Right and left limits of fire were the responsibilities of gun crews and range personnel at the time and are generally not identified on historical documents. The safety limits for cannon positions will apply to the individual cannon, except in the case of a battery, where the limits will be measured from the flank cannons. The estimated width of the impact area is 712 mils (40°).

Coastal Defense Guns: Unlike training ranges, these sites were established for national defense, therefore, would not have been subject to range regulations. The fans typically found on historical maps generally represent sectors of fire (the sector/area in which a particular gun (or guns) was responsible). Sectors were used to ensure total coverage in the event of an attack. Do not consider these as safety fans.

Targets may have included towed or moored barges and ships or target sleeves towed by aircraft.

It is likely that if a gun were fired it would have been directed towards the center of its sector, furthest from land. This fan should be drawn so that land is not within the SDZ. However, a small insignificant, uninhabited island may not have been excluded. The fan begins from the gun position; or in the case of a battery, from the two outside guns.

Caliber of Ammunition	Danger Area		
	<u>Sides (yds)</u>	<u>Rear (yds)</u>	<u>Front (yds)</u>
37mm or less	600	2,000	200
40mm to 75mm	800	2,000	500
90mm to 155mm	800	2,000	600
7" to 240mm	1,000	2,000	1,000

* 3,000 yards if firing is less than 12° elevation

The following approximate maximum ground impact ranges can be used to estimate safety zones. The list is only a select few compiled to assist with estimating safety zones. It was not uncommon for restrictions to be placed on gun elevations and propelling charges. These restrictions were used to reduce maximum ranges in order to comply with local restrictions. Example: The maximum range for a 155mm, HE, M102 fired with charge 1 at 367 mils (20.6°) elevation is equal to 3,000 yards. The same round fired with charge 7 at 843.8 mils (47°) elevation has a maximum range equal to 12,700 yards.

Standard Range Designs

Weapon	Ammunition	Elevation	Muzzle Vel (fps)	Max (approx) Range (yds)
37mm gun	Fixed, HE, MkII	22° 10'	1,276	4,300
	Practice, MkII	22° 10'	1,276	4,300
75mm gun	HE, M48, normal	43° 00'	1,500	11,195
	HE, M48, supercharged	44° 00'	1,950	13,595
	HE, M48, reduced	44° 00'	950	6,960
	Shot, AP, M61	44° 00'	2,000	13,650
	Shrapnel, MkI	43° 40'	1,755	9,750
75mm pack Howitzer	HE, M48	44° 00'	1,250	9,800
105mm Howitzer, M2	HE, M1	44° 00'	1,550	12,150
	Smoke, M84	43° 40'	1,550	12,210
105mm Howitzer, M3	HE, M1	45° 00'	1,020	8,490
	Smoke, M84	45° 00'	1,020	8,490
155mm Howitzer, M19170-18	HE, M105	44° 16'	1,476	12,775
	Sand-loaded, MkI	44° 23'	1,479	12,300
	Shrapnel, MkI	47° 26'	1,434	10,850
155mm Howitzer, M1	HE, M107	44° 00'	1,850	16,000
	HE, M101	47° 00'	2,800	25,400
	Smoke, M116	45° 00'	1,850	16,200
4.5-inch Gun, M1	HE	45° 00'	2,275	21,125
8-inch Howitzer	HE, MkI	42° 30'	1,305	10,900
	Sand-loaded, MkI	43° 45'	1,525	12,700
240mm Howitzer	HE, MkII	45° 10'	1,700	16,400
	Sand-loaded, MkIII	45° 10'	1,700	16,400

Data sheet: selection depends on known or suspected ordnance. Refer to Artillery, all types.

Reference(s): *AR 750-10, Range Regulations for Firing Ammunition in Time of Peace*, May 1939 – January 1944; *TM 9-855, Targets, Target Material, and Training Course Lay-outs*, August 1944 & November 1951

Standard Range Designs

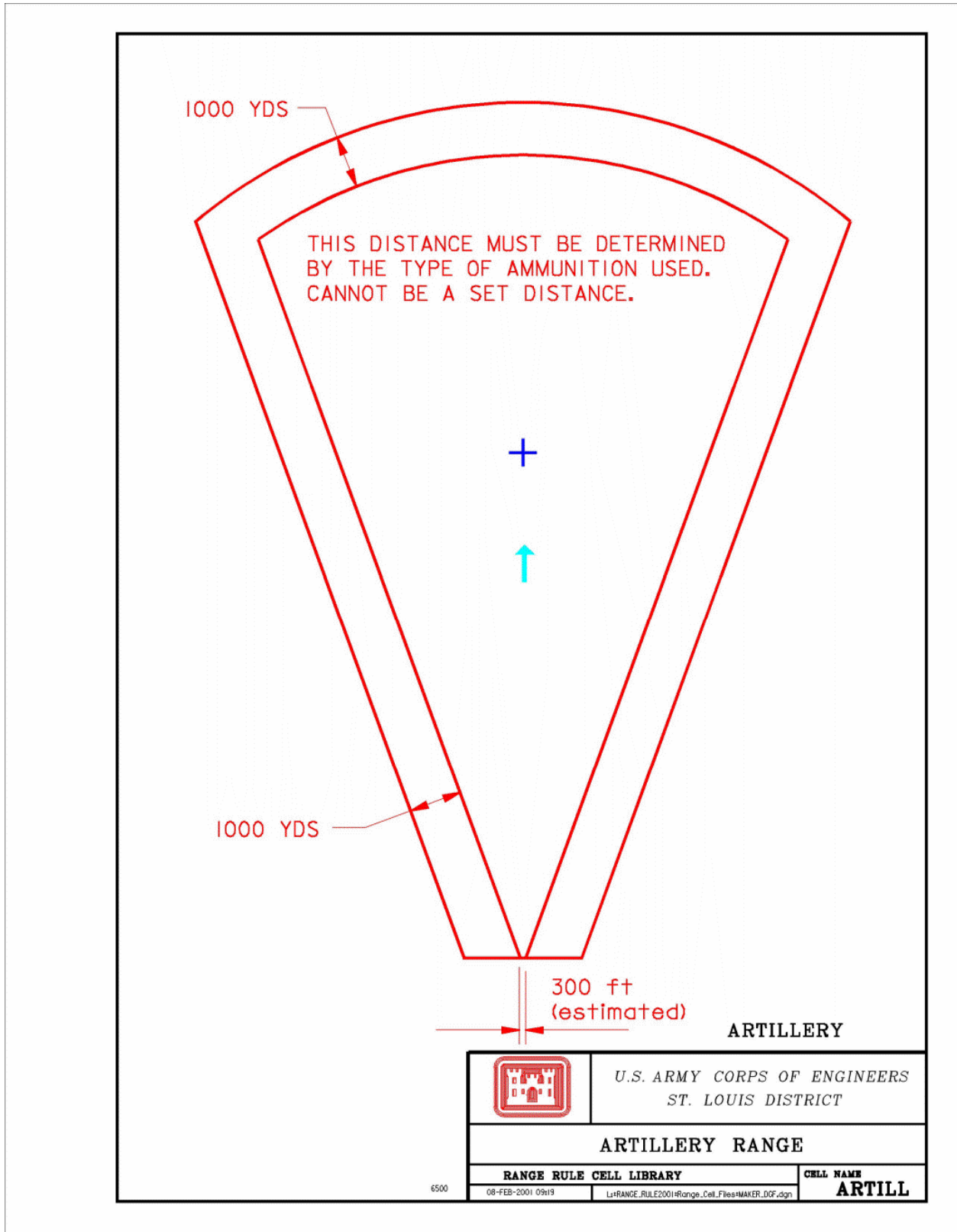

Standard Range Designs

Standard Range Designs

RECOILESS RIFLE, KNOWN DISTANCE aka: Reckless Rifle, Known Distance; Recoilless Rifle, KD; Reckless Rifle, KD)

Range Type: Artillery

Cell Name(s): RERIKD

The references used to derive this range cell illustrate these types of ranges as being 800 yards long with individual lanes spread across its width. Each firing point has a 10-yard back blast area extending to each side. This indicates that the lanes would be approximately 20 yards wide. The number of lanes depends on local conditions. As illustrated in the references, 4 lanes are specified for 57mm ammunition, and two lanes for 75mm. Targets would have consisted of 55-gal drums or 3-ft by 5-ft log barriers, and positioned at 300, 500, and 800 yards for 57mm ammunition, and at 400 and 800 yards for 75mm.

The danger area for the range consists of the impact area and danger area. The impact area extends out to the maximum range of the weapon corresponding to an elevation of 15°. Without information as to right and left limits of fire (which would have been established locally) it is estimated that limits of 20° are sufficient. Danger areas of 600 yards and 2,000 yards are added to both sides and the rear of the range, respectively.

<u>Ammunition (probable)</u>	<u>Max Range (yards)</u>	<u>Muzzle Velocity (fps)</u>
.30 caliber	3,450	2,700
.50 caliber	7,500	2,545

Data sheet(s):

CTT13	57mm Recoilless Rifle, M306A1
	57mm Recoilless Rifle, HEAT, M307
	75mm Recoilless Rifle, HE, M309A1
CTT14	57mm Recoilless Rifle, WP, M308A1
	75mm Recoilless Rifle, WP, M48A3

Reference(s): *AR 750-10, Range Regulations for Firing Ammunition in Time of Peace*, May 1939 – January 1944; *TM 9-855, Targets, Target Material, and Training Course Lay-outs*, August 1944 & November 1951

Standard Range Designs

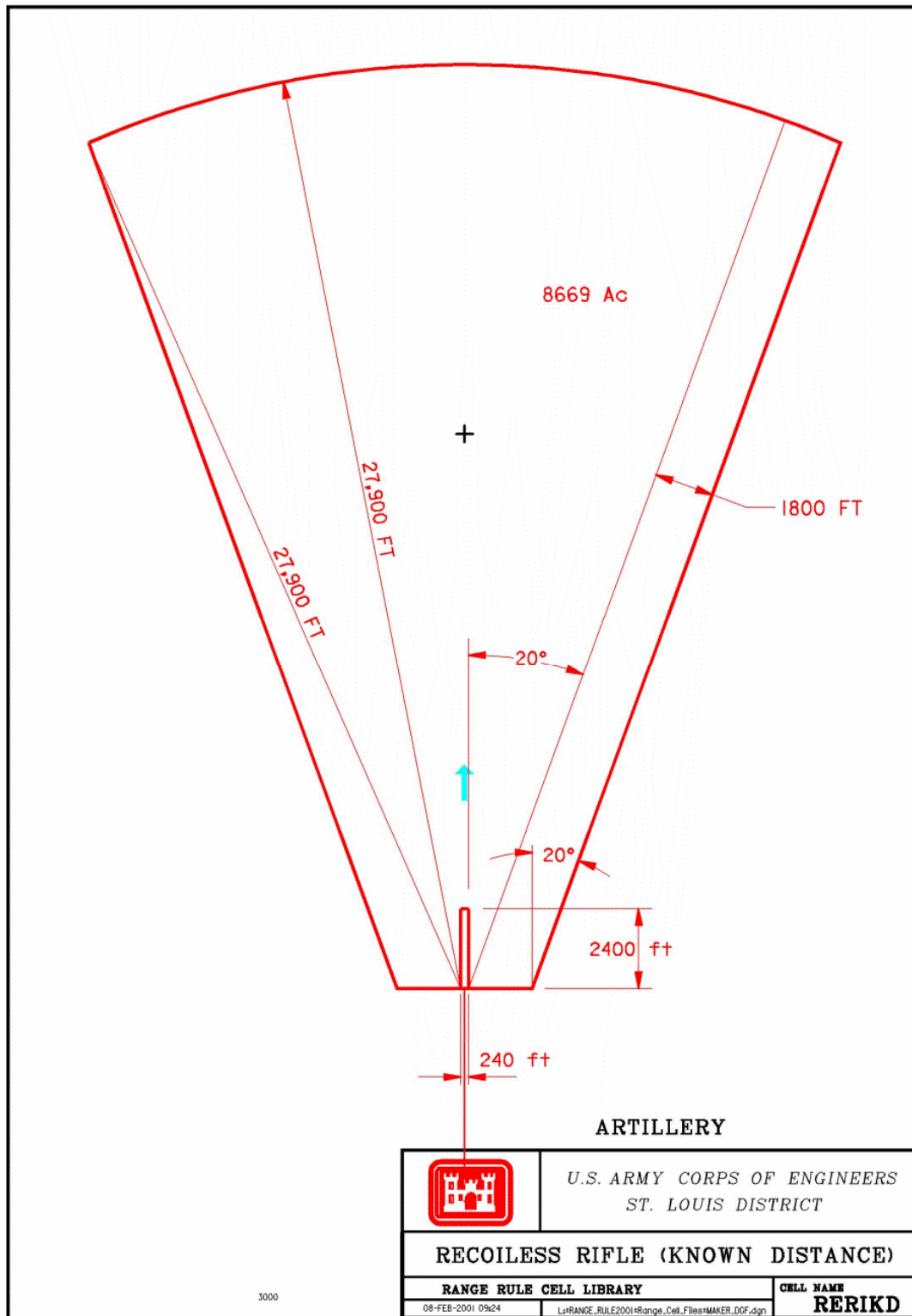

(Source: USACE-St. Louis, 2002)

Standard Range Designs

TANK (MAIN GUN)

Range Type: Artillery

Cell Name(s): Refer to artillery

A Tank Gun is considered a direct fire weapon.

Standard Range Designs

Standard Range Designs

MORTAR

Range Type: Mortar

Cell Name(s): MORTAR

A mortar range would have been laid out utilizing natural terrain features, which were varied enough to furnish reference points or targets and the desired firing distances.

This range has three areas of concern, the firing point (firing line), the impact area, and danger area. The firing line is an arbitrary dimension established by the local requirements; but 25 yards would generally be sufficient. The impact area (target area), also determined by local requirements, would begin a minimum of 600 yards from the firing point and continue down-range the maximum range of the mortars fired. The range cell was derived by estimating the right and left limits of fire and the down range distance. Therefore, the estimated angle of fire is 30°. The down range distance of the cell was derived using an 81mm HE, M43 mortar as worst case, which has a maximum range of 3,300 yards. Regulations required an additional 600-yard danger area applied to each side and to the downrange distance.

<u>Ammunition (probable)</u>	<u>Max Range (yards)</u>
60mm, Training	350
60mm, Practice	1,935
60mm, High Explosive	1,935
60mm, Smoke	1,610
60mm, Illumination	1,100
81mm, Training	350
81mm, Practice	3,300
81mm, High Explosive	3,300
81mm, Smoke	2,470
81mm, Illumination	2,300
3-inch, Stokes	750

Data sheet(s):

CTT01	Small arms, General
CTT16	60mm, HE, M49 81mm, HE, M43
CTT18	60mm, Training, M69 60mm, Practice, M50A2 81mm, Training, M68 81mm, Practice, M43A1

Reference(s): AR 750-10, *Range Regulations for Firing Ammunition in Time of Peace*, May 1939 – January 1944; TM 9-855, *Targets, Target Material, and Training Course Lay-outs*, August 1944 & November 1951; FM 23-30, *Hand and Rifle Grenades, Rocket, AT, HE, 2.36-inch*, February 1944

Standard Range Designs

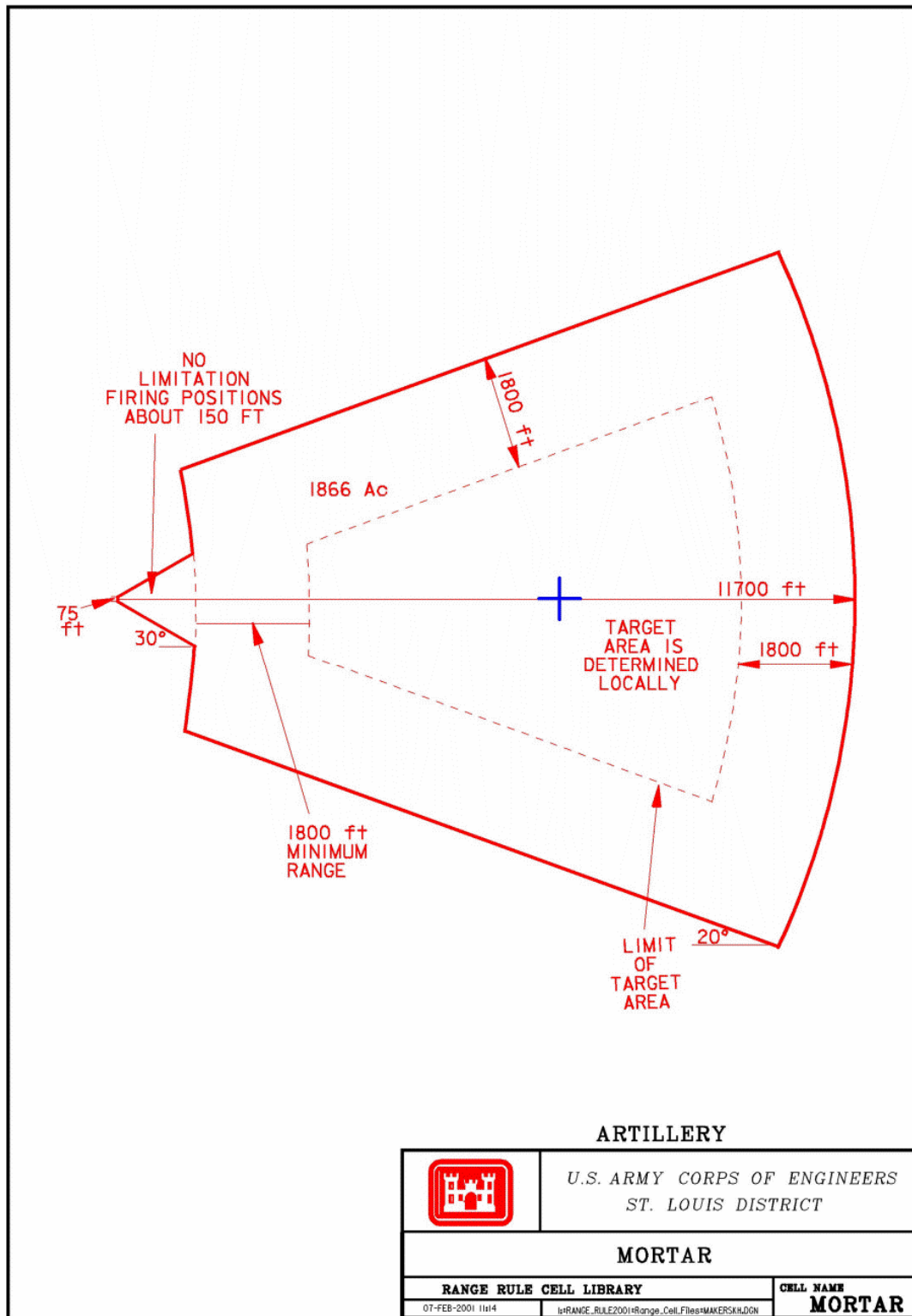

Standard Range Designs

MORTAR, 4.2-inch SUB-CALIBER

Range Type: Mortar

Cell Name(s): MORT42

The 4.2-inch mortar, equipped with the subcaliber assembly, may be used on a training shell range, firing the training shell. The training shell range would have consisted of a target area, an observation post (OP), a mortar position, and a fire direction center (FDC). The width of the range depended on the number of platoons to be trained at one time. A width of 100 feet, the width of the range cell, was determined to be adequate for one platoon.

The target area consisted of range markers and targets, which were constructed of scrap lumber. The range markers were placed at 100-foot intervals; with the first being 400 feet from the OP and continuing out to 700 feet. Mortars would have been mounted laterally and positioned approximately 15 feet apart.

<u>Ammunition (probable)</u>	<u>Max Range (yards)</u>
3-inch, M5 (subcaliber)	Unknown

Data sheet(s):

CTT18 3-inch, Subcaliber, M5

Reference(s): *AR 750-10, Range Regulations for Firing Ammunition in Time of Peace*, May 1939 – January 1944; *TM 9-855, Targets, Target Material, and Training Course Lay-outs*, August 1944 & November 1951; *TM 9-1901, Artillery Ammunition*, September 1950

Standard Range Designs

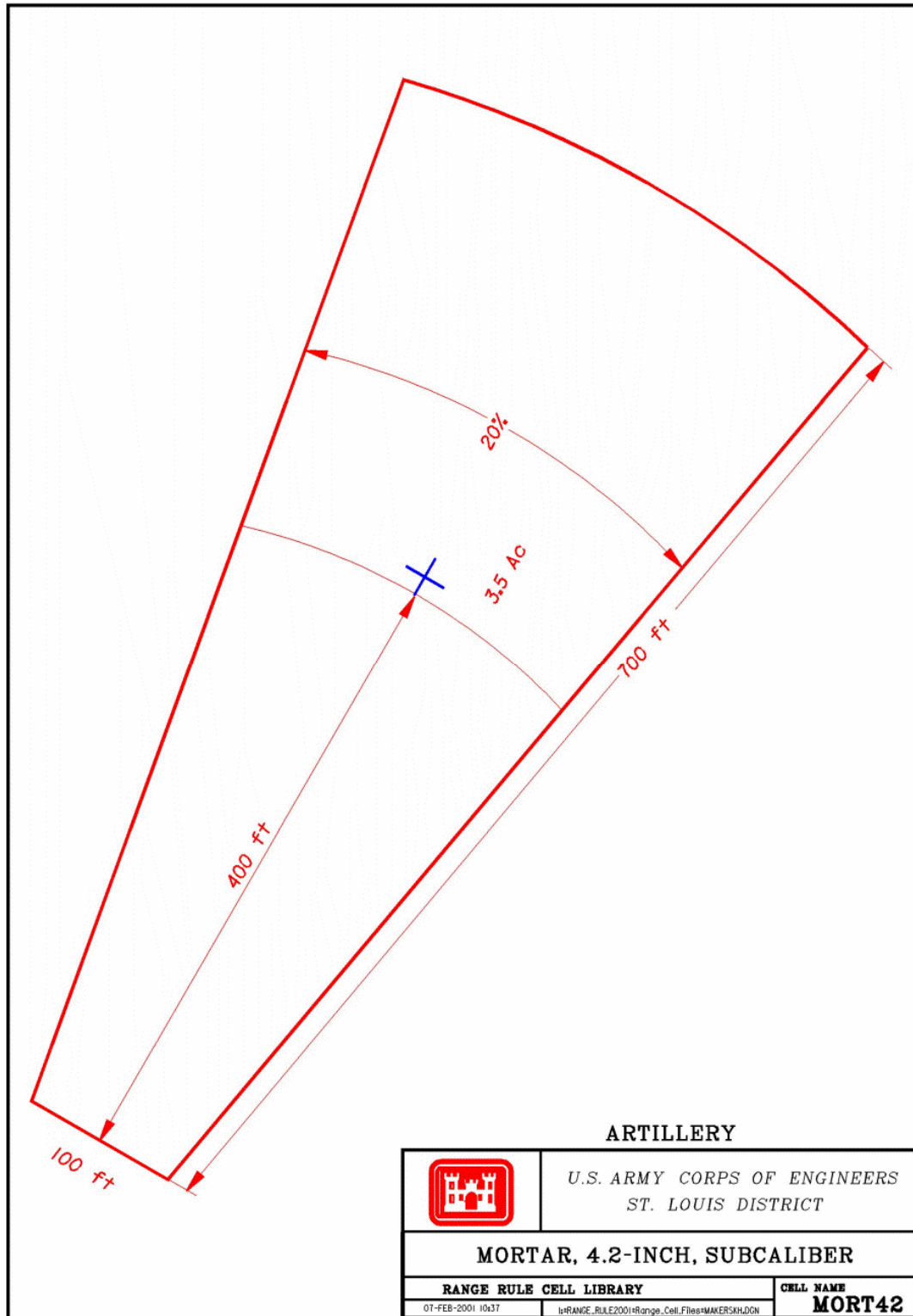

(Source: USACE-St. Louis, 2002)

Standard Range Designs

GRENADE COURT, PRACTICE (aka: Practice Grenade Range)

Range Type: Hand Grenade

Cell Name(s): GRENP

Practice grenade courts were generally constructed near live grenade ranges in order to allow training prior to throwing a live grenade. A typical practice court consisted of a number of individual courts designed to allow men to throw a practice grenade under a variety of conditions. Five practice courts, of which all or any could have been utilized, are described in the regulations. This type of range would have used any available area and have been laid out according to local conditions. The required area for all five courts, as shown in the range cell, would be approximately 50 yards by 200 yards. No danger area is warranted for this area.

- **Main Court** – The main court is laid out 40 yards wide by 35 yards long. Boundaries are outlined with 2-inch strips of canvas or target cloth placed across the court parallel to the throwing line. The court contains five targets, which are 1 yard in depth, positioned between 15 and 35 yards. This court accommodated 64 men but could be doubled by increasing its length from 35 yards to 60 yards and placing throwing lines at both ends.
- **Crater Court:** The crater court was constructed by digging a circular pit 3 yards in diameter and a minimum of 18 inches deep. The throwing line is marked by a strip of white tape placed 26½ yards from the center of this pit. Depending on the class size, the throwing line may completely encircle the pit or be an arc a minimum of 4 feet.
- **Foxhole Court:** The foxhole court is constructed by digging a simulated shell crater and three shallow foxholes. The crater is used as the throwing area. The foxholes are dug 20 yards from the crater at a 45° angle.
- **Vertical Target Court:** Vertical target courts are built to look like four windows of a house at different heights from the ground. The windows (targets) are constructed of lumber and positioned 20 yards from the throwing line.
- **Woods Court:** The woods court consists of chicken wire stretched over frames or stakes 3-4 feet above the ground. Targets were positioned approximately 12 yards to the front of the firing line.

Ammunition (probable)

Hand Grenade, Practice

Hand Grenade, Training

Data sheet(s):

CTT04	M21, Practice Hand Grenade
	Mk1A1, Training Hand Grenade

Reference(s): AR 750-10, *Range Regulations for Firing Ammunition in Time of Peace*, May 1939 – January 1944; TM 9-855, *Targets, Target Material, and Training Course Lay-outs*, August 1944 & November 1951

Standard Range Designs

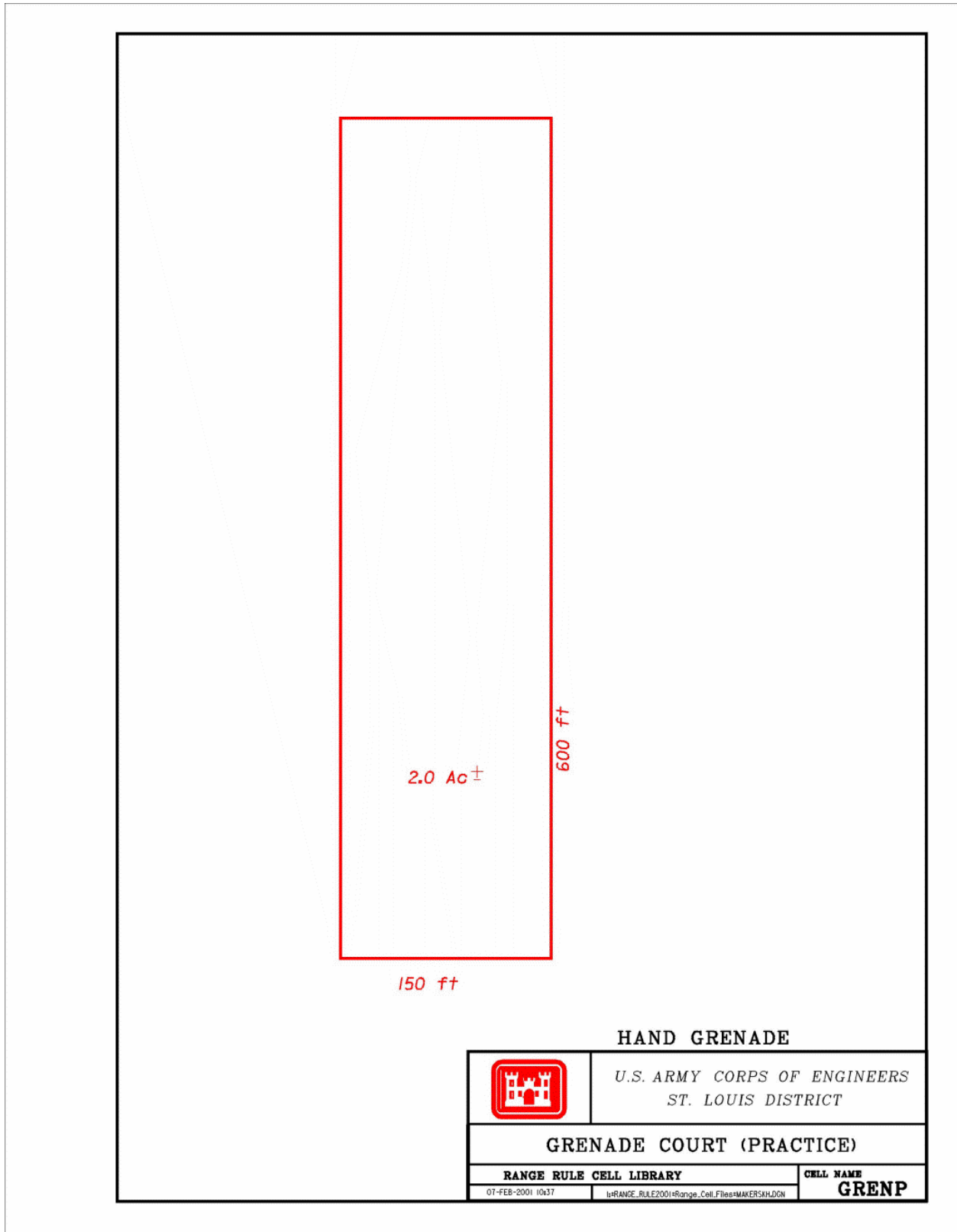

Standard Range Designs

GRENADE COURT, LIVE (aka: Grenade Range)

Range Type: Grenade

Cell Name(s): HGRENA

A 6-bay grenade range (as shown in the cell) would require an area approximately 40 yards wide by 50 yards long. It consisted of individual throwing bays (described in a 1951 regulation) or a trench (described in a 1944 regulation) with targets and an impact area approximately 25 yards to the front of the throwing line. The regulations describe the range being laid out with a ready line situated behind a barrier at least 5 feet high, and a throwing area situated a minimum of 15 yards to the front of this barrier. The throwing bays may have been constructed from sandbags or concrete. Targets consisted of a circular outline, a crater, and/or a foxhole. A danger area of approximately 600 feet would have been established around the entire range.

Ammunition (probable)

Hand Grenade, Fragmentation

Data sheet(s):

CTT02 Mk II, Hand Grenade, Frag

Reference(s): *AR 750-10, Range Regulations for Firing Ammunition in Time of Peace*, May 1939 – January 1944; *TM 9-855, Targets, Target Material, and Training Course Lay-outs*, August 1944 & November 1951

Standard Range Designs

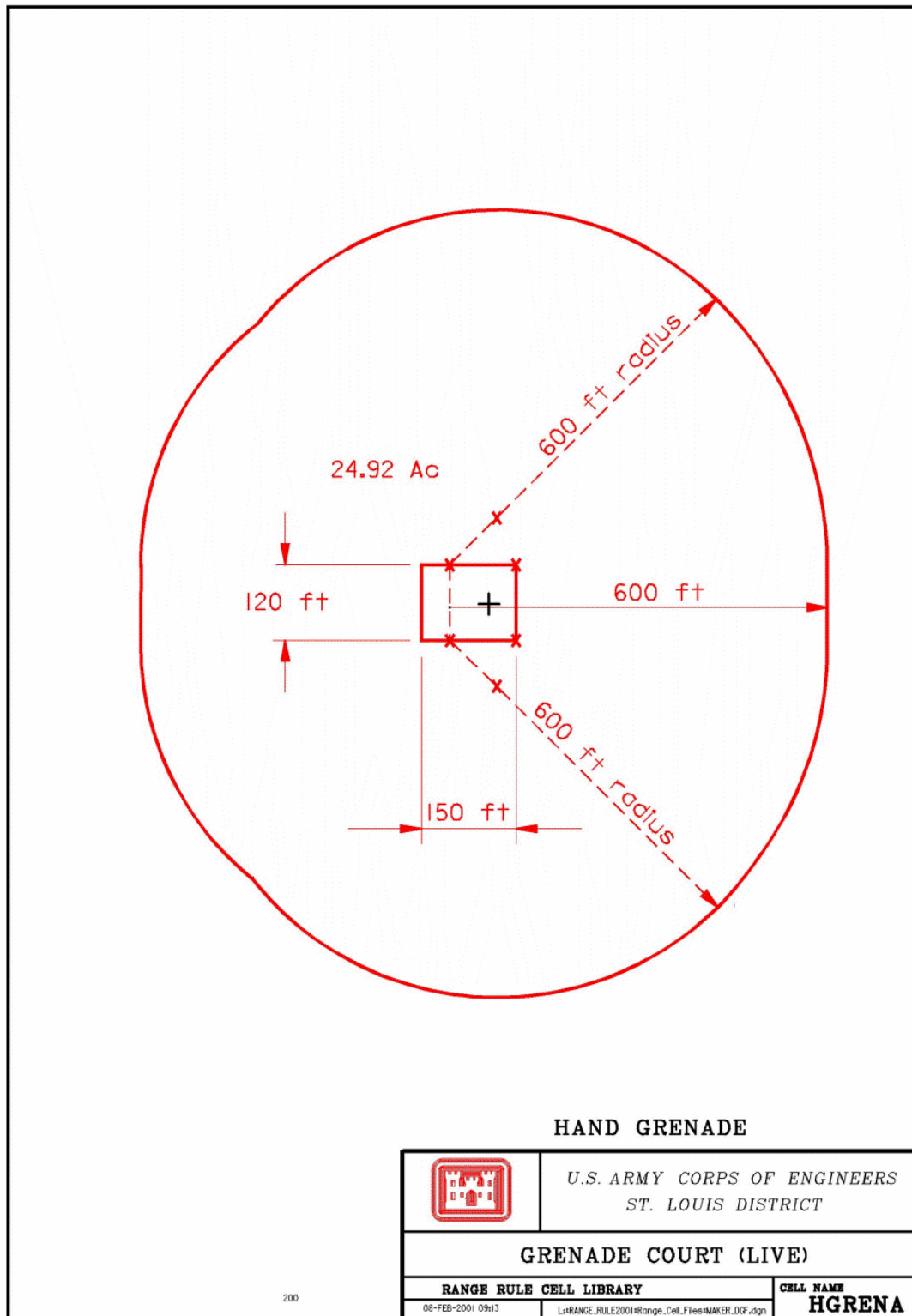

Standard Range Designs

GRENADE ASSAULT COURSE

Range Type: Grenade

Cell Name(s): AGREN

A grenade assault course would be laid out on rough, preferably sparsely wooded terrain, and may vary in length from 150 to 200 yards. The width of the range should be no more than 40 yards. Stations were established along the course giving the soldiers a variety of situations. Targets would simulate machine gun emplacements, tank mock-ups, foxhole, etc. At each station, men would be required to select the correct type of grenade in which to engage the particular target. The number and types of targets were determined by local conditions. Typically, training grenades were used. However, a Field Manual (FM) notes that live grenades, smoke grenades, and incendiary grenades may be used at some stations. If live grenades were utilized, a 200-yard safety fan would be required surrounding the range. The range cell assumes that live grenades were used. However, if it is known that only training and practice grenades were used, this safety fan would be deleted from the cell.

Ammunition (probable)

Hand Grenade, Practice

Hand Grenade, Training

Hand Grenade, Frangible

Hand Grenade, Fragmentation

Hand Grenade, Incendiary

Hand Grenade, Smoke

Data sheet(s):

CTT02	MkII Hand Grenade, Frag
CTT03	AN-M14, Incendiary Grenade AN-M8, Smoke Grenade, HC M1, Frangible
CTT04	M21, Practice Hand Grenade Mk 1A1, Training Hand Grenade

Reference(s): *FM 23-30, Hand and Rifle Grenades, Rockets, AT, HE, 2.36-inch*, February 1944; *AR 750-10, Range Regulations for Firing Ammunition in Time of Peace*, May 1939 - January 1944.

Standard Range Designs

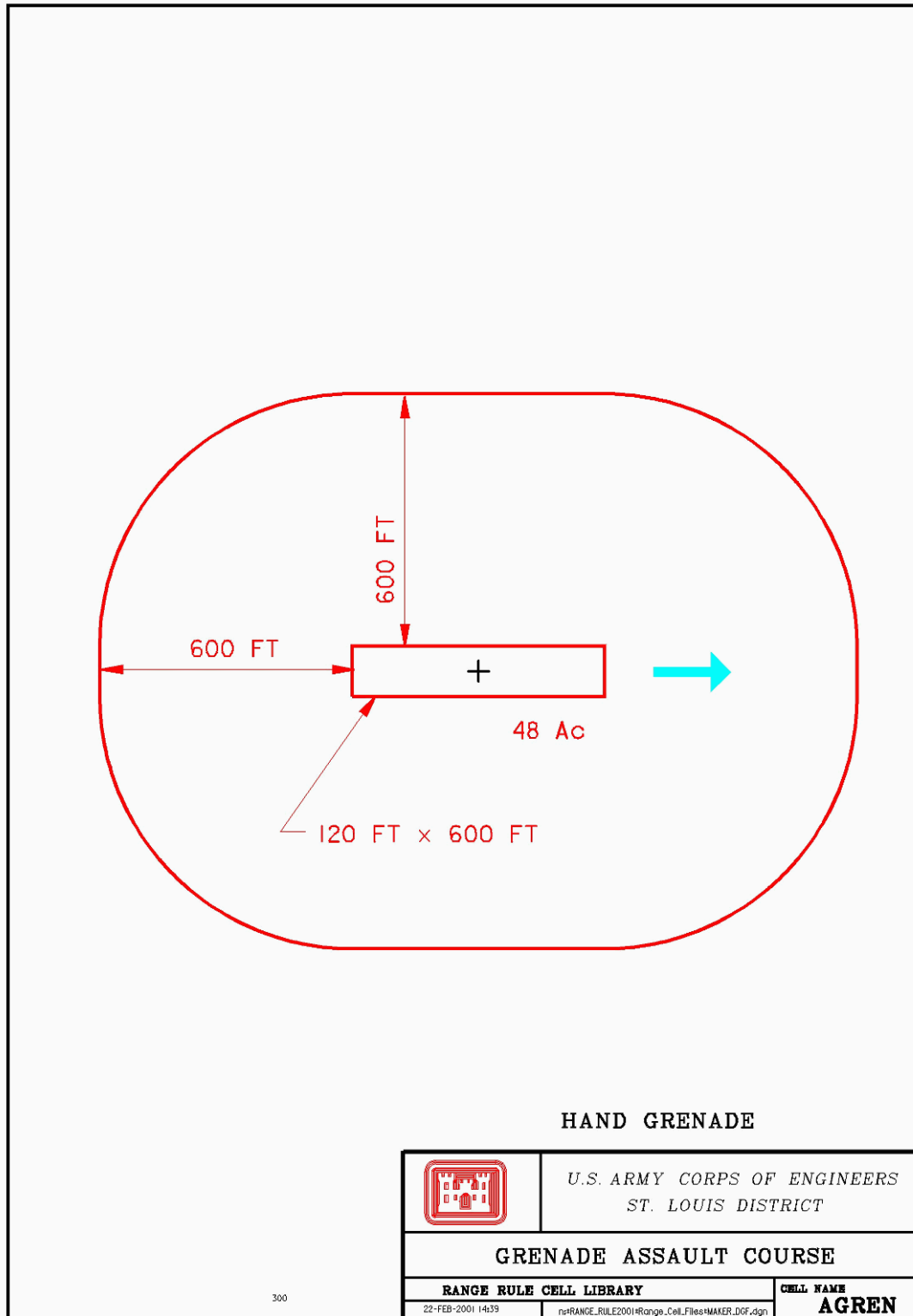

Standard Range Designs

RIFLE GRENADE (PRACTICE)

Range Type: Rifle Grenade/Anti-Tank Rocket

Cell Name(s): RGREN

As stated in the regulations, “The number of targets and firing points depends upon local conditions.” The safety zone extended 500 feet beyond all targets.

Three types of rifle grenade ranges are described below. One or all of these types could have been located on the rifle grenade range depicted in the range cell.

- Antipersonnel Marksmanship
 - o High trajectory fire – the range would encompass an area 200 yards long and approximately 40 yards wide with targets located at the far end. Firing points would be established at ranges of 50, 100, 150, and 200 yards. Foxholes are dug at the 200-yard firing position.
 - o Flat trajectory fire – this court is 75 yards long and has 6 targets at the far end. Sandbags are placed at the 25-yard mark, shell craters are dug at the 50-yard mark, and stakes indicate other firing points at the 75-yard mark.
- Antitank Marksmanship
 - o A court for known-distance firing at stationary targets would consist of a single firing line using shell craters and/or 1-man foxholes for firing positions. Targets would be located at 25 yards, 37½ yards, and 75 yards.
 - o A court for firing at moving targets could and most likely be constructed on the same stationary target court. Moving targets would either be towed parallel or perpendicular to the firing line. All firing positions are allowed to use one target when towed parallel to the firing line. However, only two firing positions are allowed to use one target when towed perpendicular to the firing line.
- Antitank Field Firing – This ground towed target range may be utilized for field firing exercises with practice antitank grenades. Several standing-type 1-man foxholes or shell craters at a location near the center of the range would be constructed.

Since practice antitank rifle grenades do not contain an explosive charge, training in their use may be given in any area where troops are not within a distance of 200 yards to the rear of the target. In order to minimize damage to fin assemblies, an area free from trees, stumps, rocks, and other hard objects would have been selected.

<u>Ammunition (probable)</u>	<u>Max Range (yards)</u>
Practice Rifle Grenades	<400

Data sheet(s):
CTT10 M11A2, Practice, Rifle Grenade

Reference(s): *FM 23-30, Hand and Rifle Grenades, Rockets, AT, HE, 2.36-inch*, February 1944; *AR 750-10, Range Regulations for Firing Ammunition in Time of Peace*, May 1939 – January 1944.

Standard Range Designs

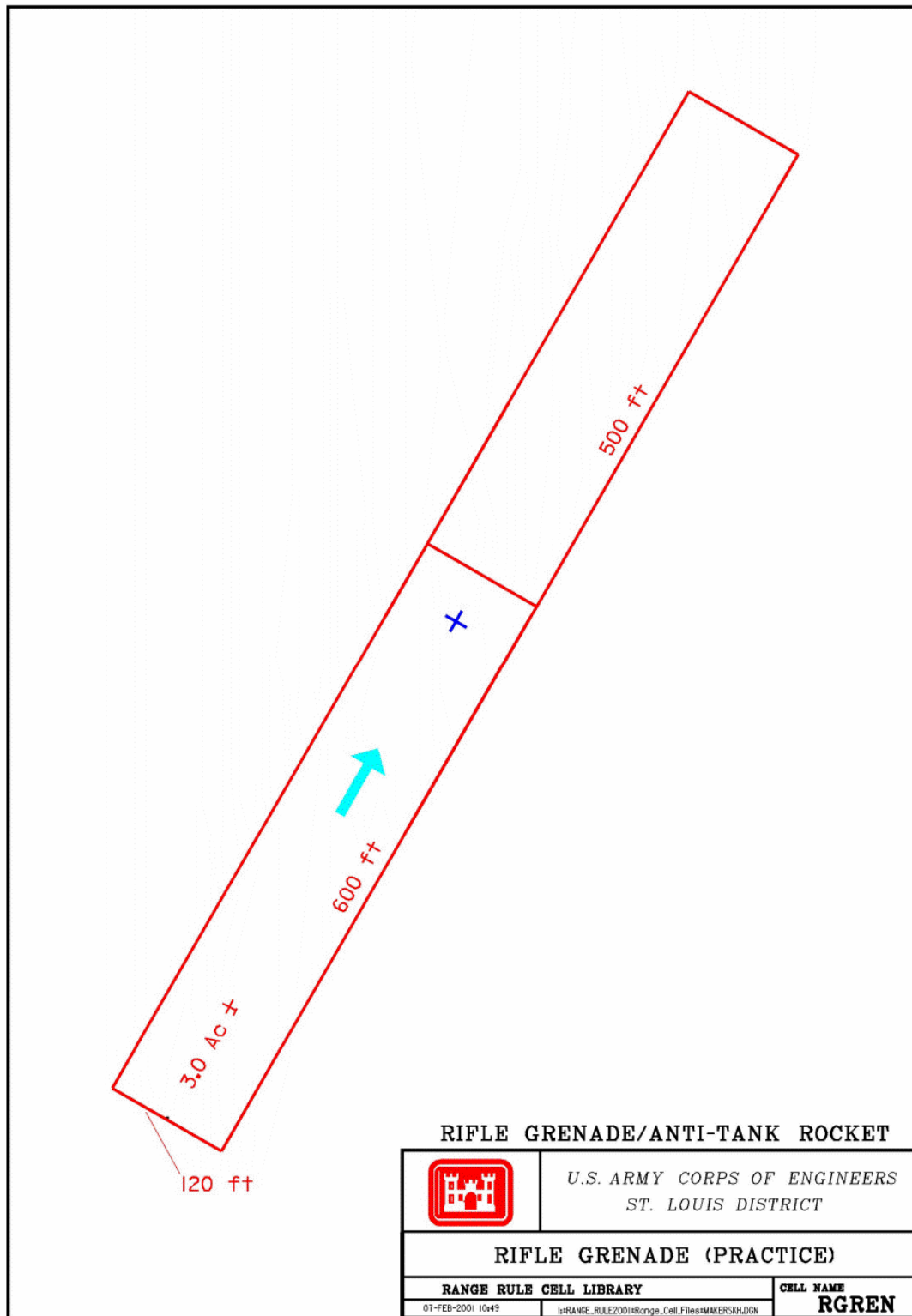

Standard Range Designs

40mm GRENADE LAUNCHERS M79 AND M203 (HE)

Range Type: Rifle Grenade/Anti-Tank Rocket

Cell Name(s): L40mmG

The surface danger zone represents three firing lanes. Additional firing positions may be added if a minimum separation of 6 meters is maintained between positions.

For the Mk19, 40mm machine gun (MG), the distance to the back of the impact area is 2,000m and will not be reduced.

Ammunition (probable)

40mm HE

40mm Practice

40mm Illumination

Data sheet(s):

CTT13	40mm, HE, M381
	40mm, HE, M386
	40mm, HE, M406
	40mm, HEDP, M433
CTT14	40mm, Parachute, Star, M583, M661, M662
CTT15	40mm, Practice, M382
	40mm, Practice, M407
	40mm, Practice, M781

Reference(s): AR 385-63, *Policies and Procedures for Firing Ammunition for Training, Target Practice, and Combat*, November 1983.

Standard Range Designs

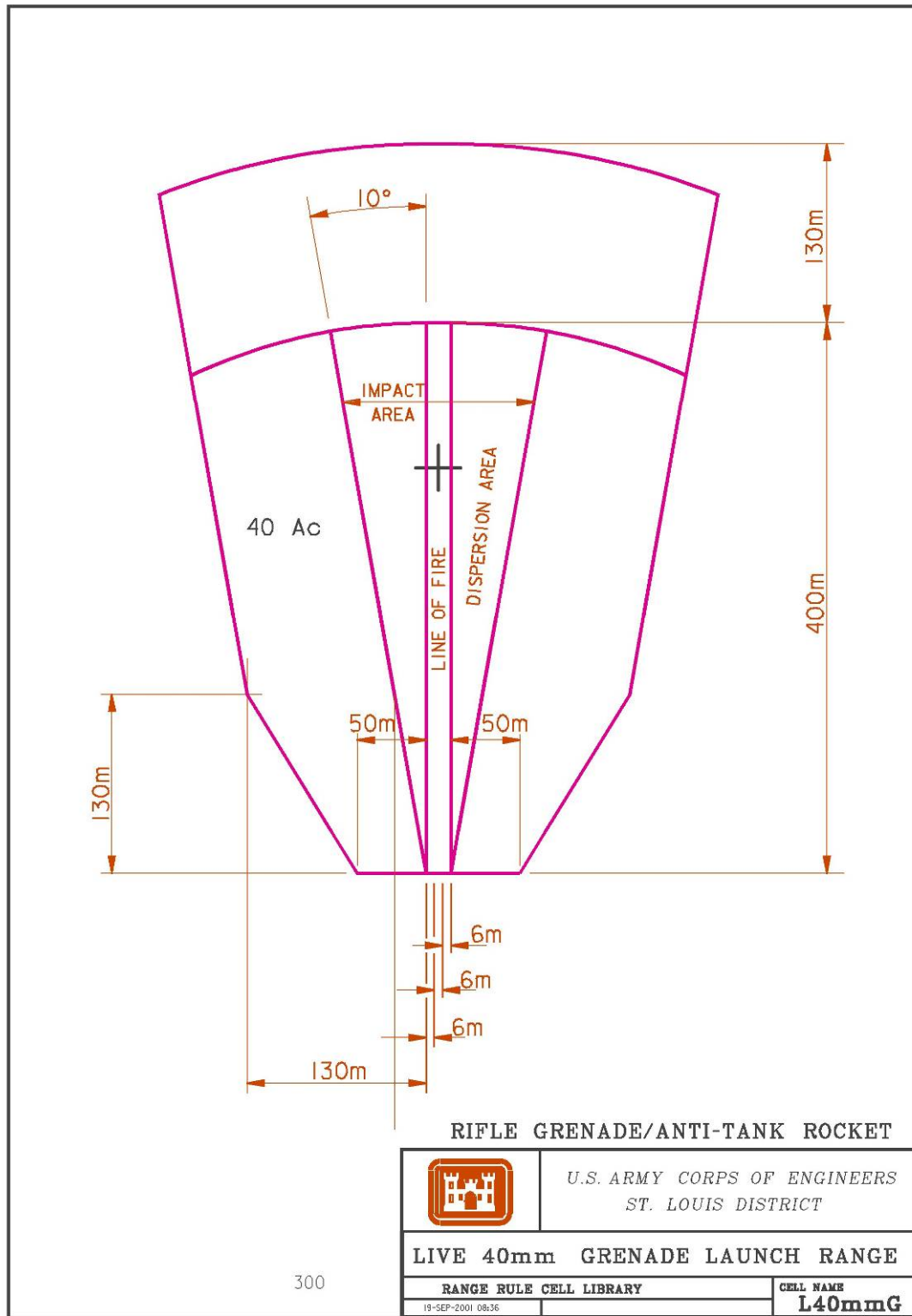

P:\oew\ RANGE_RULE2001\Range_Cells\R0_ROCKET_Live_40mm_GrenLaunch.dgn

Standard Range Designs

40mm GRENADE LAUNCHERS M79 AND M203 (PRACTICE)

Range Type: Rifle Grenade/Anti-Tank Rocket

Cell Name(s): P40mmG

The surface danger zone represents three firing lanes. Additional firing positions may be added if a minimum separation of 6 meters is maintained between positions.

For the Mk19, 40mm machine gun (MG), the distance to the back of the impact area is 2,000m and will not be reduced.

Ammunition (probable)

40mm Practice

40mm Illumination

Data sheet(s):

CTT14 40mm, Parachute, Star, M583, M661, M662

CTT15 40mm, Practice, M382

40mm, Practice, M407

40mm, Practice, M781

Reference(s): AR 385-63, *Policies and Procedures for Firing Ammunition for Training, Target Practice, and Combat*, November 1983.

Standard Range Designs

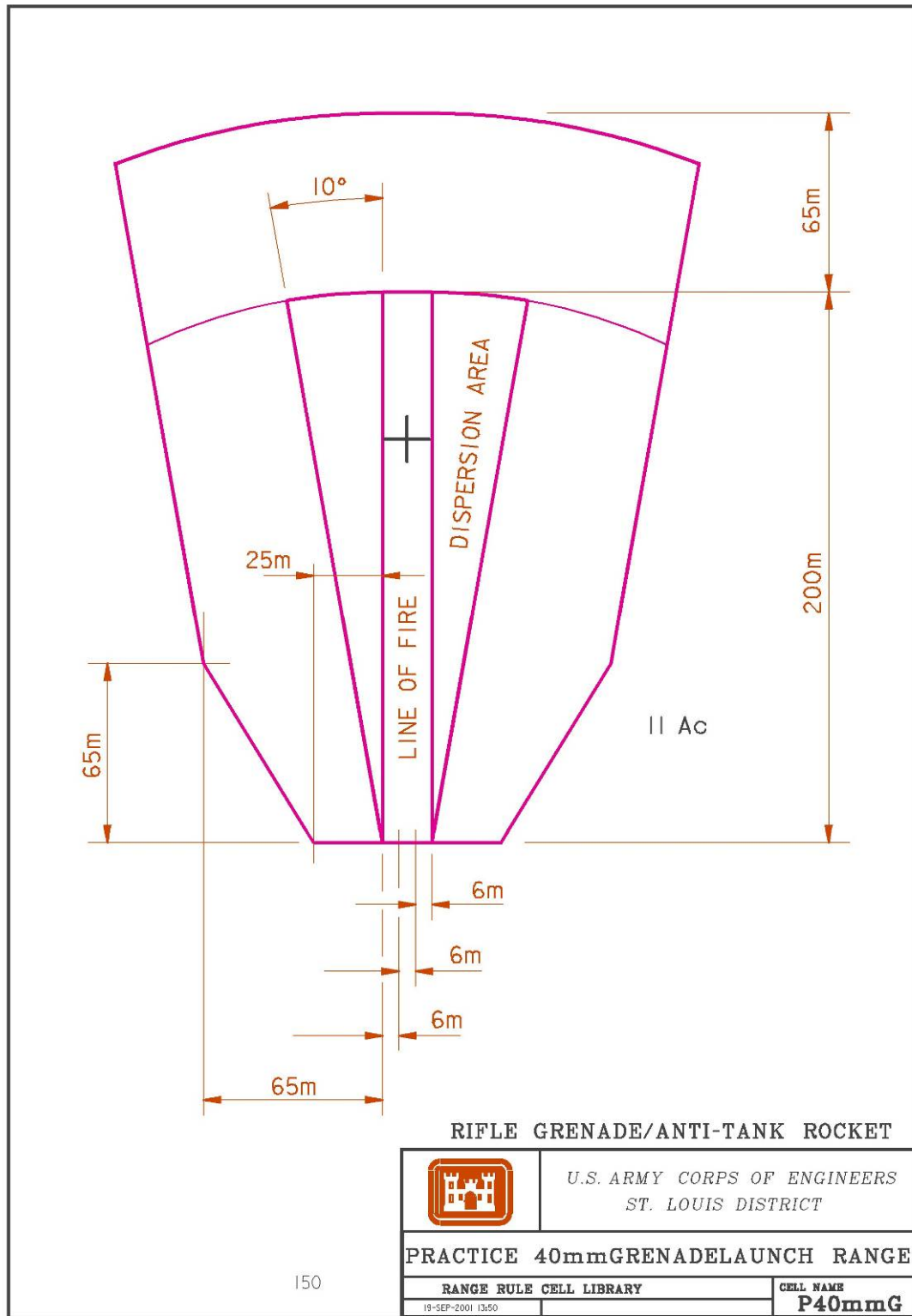

Standard Range Designs

ROCKET, 2.36-inch (MOVING TARGETS)

Range Type: Rifle Grenade/Anti-Tank Rocket

Cell Name(s): RRMT

A moving target range may incorporate one or two firing lines. Typically no more than four launchers were used simultaneously. Targets, measuring 15-18 feet long by 6-8 feet high, were pulled through the target area with the use of ropes and pulleys. Targets were fired upon from a distance of 100, 200, and 300 yards. The impact area would begin at the short limit of the targets (100 yards from the targets in this case) and extend to the maximum range of the rocket (approximately 700 yards).

Target areas would have been established with consideration given to terrain and local restrictions; however, a width of 356 mils (20°) is assumed for this range cell. An angle of fire (30°) is established by adding 20° to each side of the target area.

The safety fan includes a 300-yard danger zone beyond the impact area, plus a 200-yard danger zone parallel to the angle of fire that extends the length of the range.

Note: Rifle Grenades were commonly used on these ranges.

<u>Ammunition (probable)</u>	<u>Max Range (yards)</u>
Rocket, 2.36" Anti-tank	700
Rocket, 2.36" Practice	700
Rifle Grenade, Anti-tank	<400
Rifle Grenade, Practice	<400

Data sheet(s):

CTT08	M6A1, Rocket, HEAT, 2.36"
	M6A3, Rocket, HEAT, 2.36"
	M9A1, Rifle Grenade, Anti Tank
CTT10	M7A1, Rocket, Practice, 2.36"
	M7A3, Rocket, Practice, 2.36"
	M11A2, Practice, Rifle Grenade

Reference(s): AR 750-10, *Range Regulations for Firing Ammunition in Time of Peace*, May 1939 – January 1944; TM 9-855, *Targets, Target Material, and Training Course Lay-outs*, August 1944 & Nov 1951; TM 9-294, *2.36-inch A.T. Rocket Launcher M1A1*, September 1943; FM 23-30, *Hand and Rifle Grenades, Rocket, AT, HE, 2.36-inch*, February 1944

Standard Range Designs

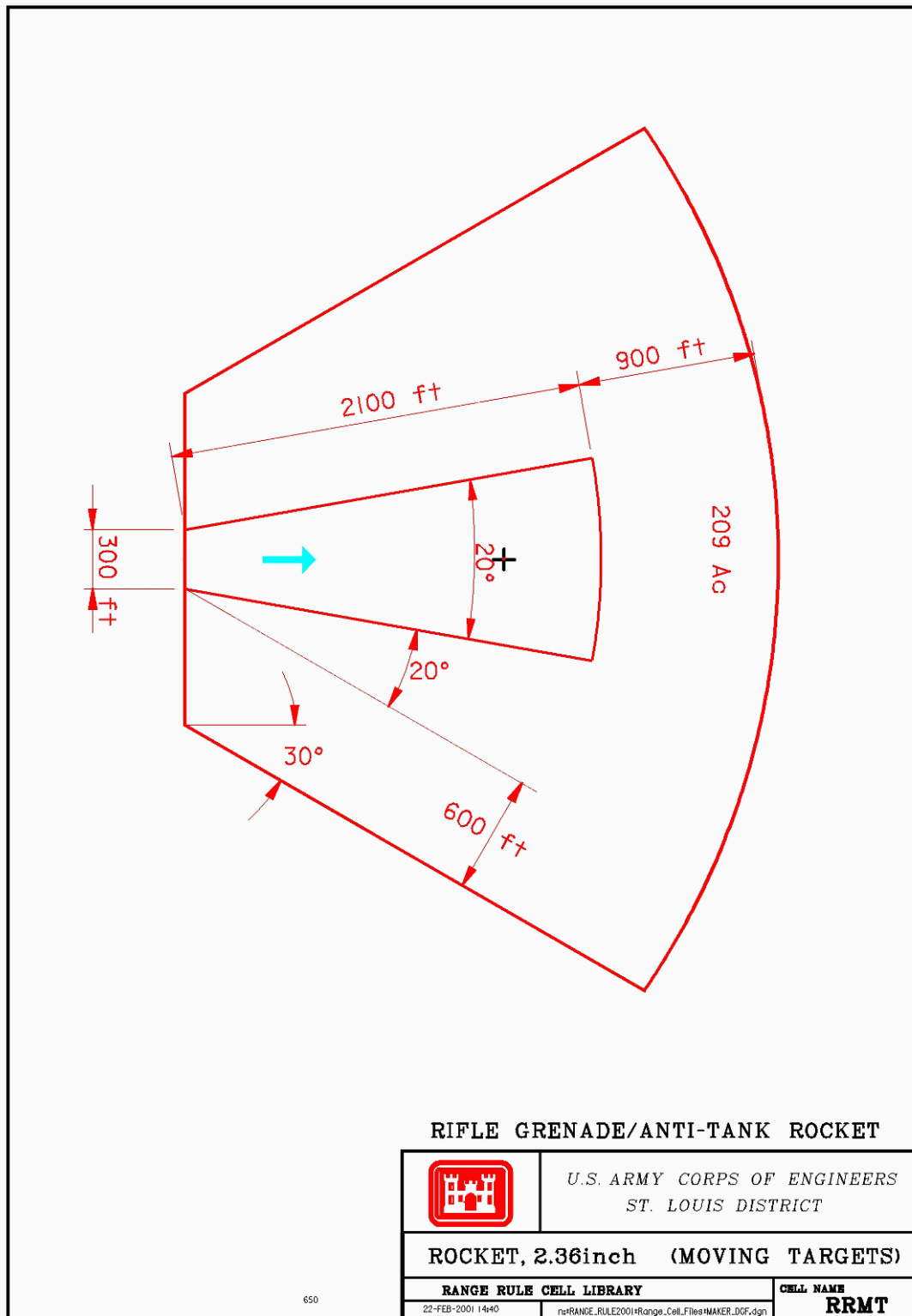

Standard Range Designs

ROCKET, 2.36-inch (STATIONARY TARGETS)

Range Type: Rifle Grenade/Anti-Tank Rocket

Cell Name(s): ROCKET

Target areas would have been established with consideration given to terrain and local restrictions; however, a width of 356 mils (20°) is assumed for this range cell. Targets would have been located at 100, 200, and 300 yards, with some down range as far as 650 yards. Typically, targets would have been at least 10 feet square and constructed from paper, cloth, wood, or metal. However, targets would have been constructed of wood or metal when high explosive rockets were used. The impact area would begin at the short limit of the target area (100 yards for this range cell) and extend to the maximum range of the rocket (approximately 700 yards). A 20° angle of fire is established by adding 10° to each side of the target area (assumed to be 20° wide). The safety fan includes a 300-yard danger zone beyond the impact area, plus a 200-yard danger zone parallel to the angle of fire that extends the length of the range.

Note: Rifle grenades were commonly used on these ranges.

<u>Ammunition (probable)</u>	<u>Max Range (yards)</u>
Rocket, 2.36" Anti-tank	700
Rocket, 2.36" Practice	700
Rifle Grenade, Anti-tank	<400
Rifle Grenade, Practice	<400

Data sheet(s):

CTT08	M6A1, Rocket, HEAT, 2.36"
	M6A3, Rocket, HEAT, 2.36"
	M9A1, Rifle Grenade, Anti Tank
CTT10	M7A1, Rocket, Practice, 2.36"
	M7A3, Rocket, Practice, 2.36"
	M11A2, Practice, Rifle Grenade

Reference(s): AR 750-10, *Range Regulations for Firing Ammunition in Time of Peace*, May 1939 – January 1944; TM 9-855, *Targets, Target Material, and Training Course Lay-outs*, August 1944 & November 1951; TM 9-294, *2.36-inch A.T. Rocket Launcher M1A1*, September 1943; FM 23-30, *Hand and Rifle Grenades, Rocket, AT, HE, 2.36-inch*, February 1944

Standard Range Designs

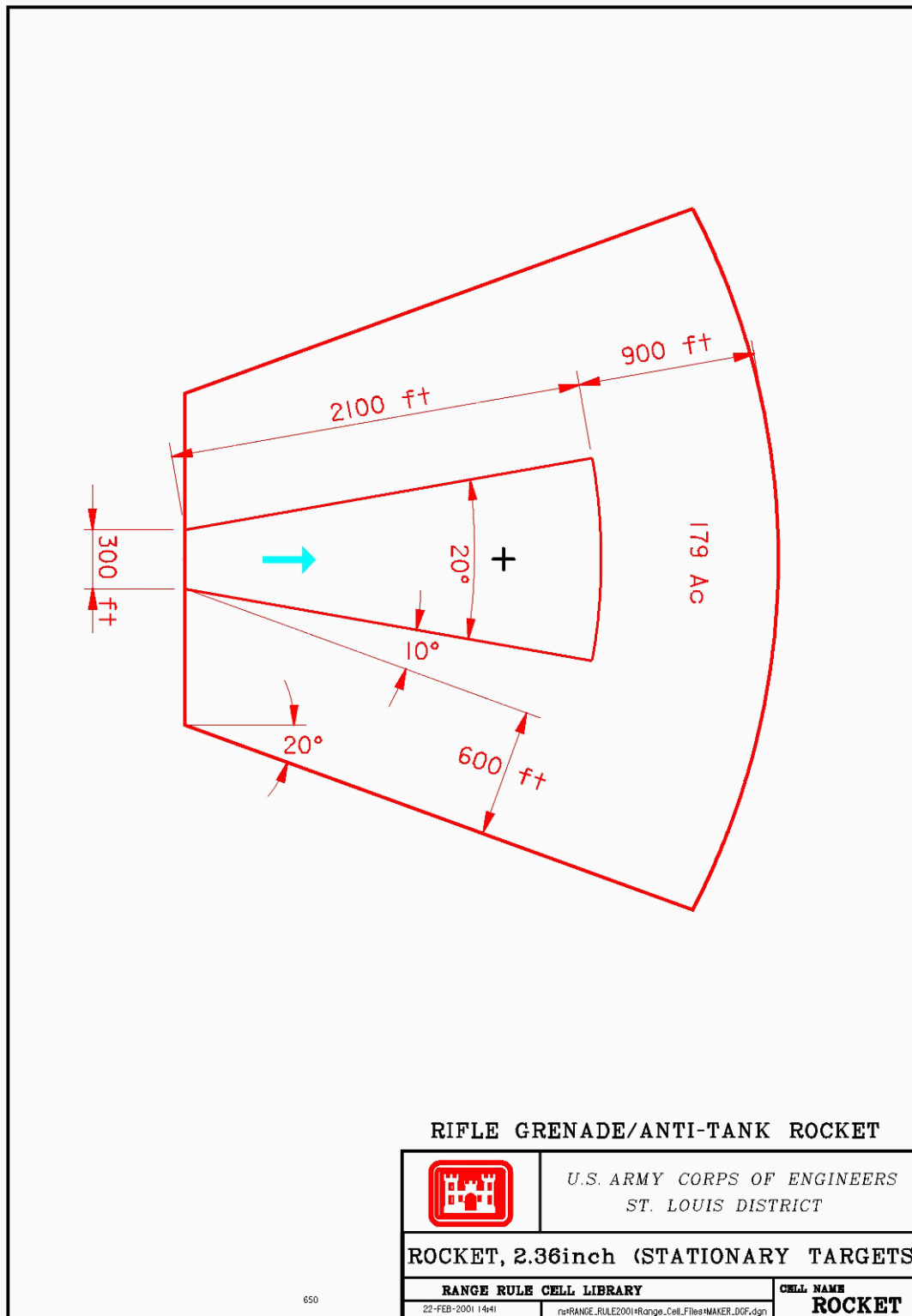

Standard Range Designs

ROCKET, 3.5-inch (MOVING TARGETS)

Range Type: Rifle Grenade/Anti-Tank Rocket

Cell Name(s): ROCKMT

The target area would have been established with consideration given to terrain and local restrictions; however, a width of 356 mils (20°) is assumed for this range cell. The target locations are not described in the references used to derive this range cell. The impact area begins at the short limit of the target area and extends to the maximum range of the rocket (1,300 yards for practice rockets). A 30° angle of fire is established by adding 20° to each side of the target area. The safety fan includes a 300-yard danger zone beyond the impact area, plus a 300-yard danger zone parallel to the angle of fire that extends the length of the range.

Note: This range was not available during WWII, but rather sometime around the end of the Korean War.

<u>Ammunition</u>	<u>Max Range (yards)</u>
Rocket, 3.5" Practice	1,300

<u>Ammunition (possible)</u>	<u>Max Range (yards)</u>
Rocket, 3.5" Anti-tank	945
Rocket, 3.5" WP	945

Data sheet(s):

CTT09	M30, Rocket, WP, 3.5"
CTT10	M28, Rocket, HEAT, 3.5"
	M29, Practice Rocket, 3.5"

Reference(s): *Targets, Target Material, and Training Course Lay-outs*, November 1951

Standard Range Designs

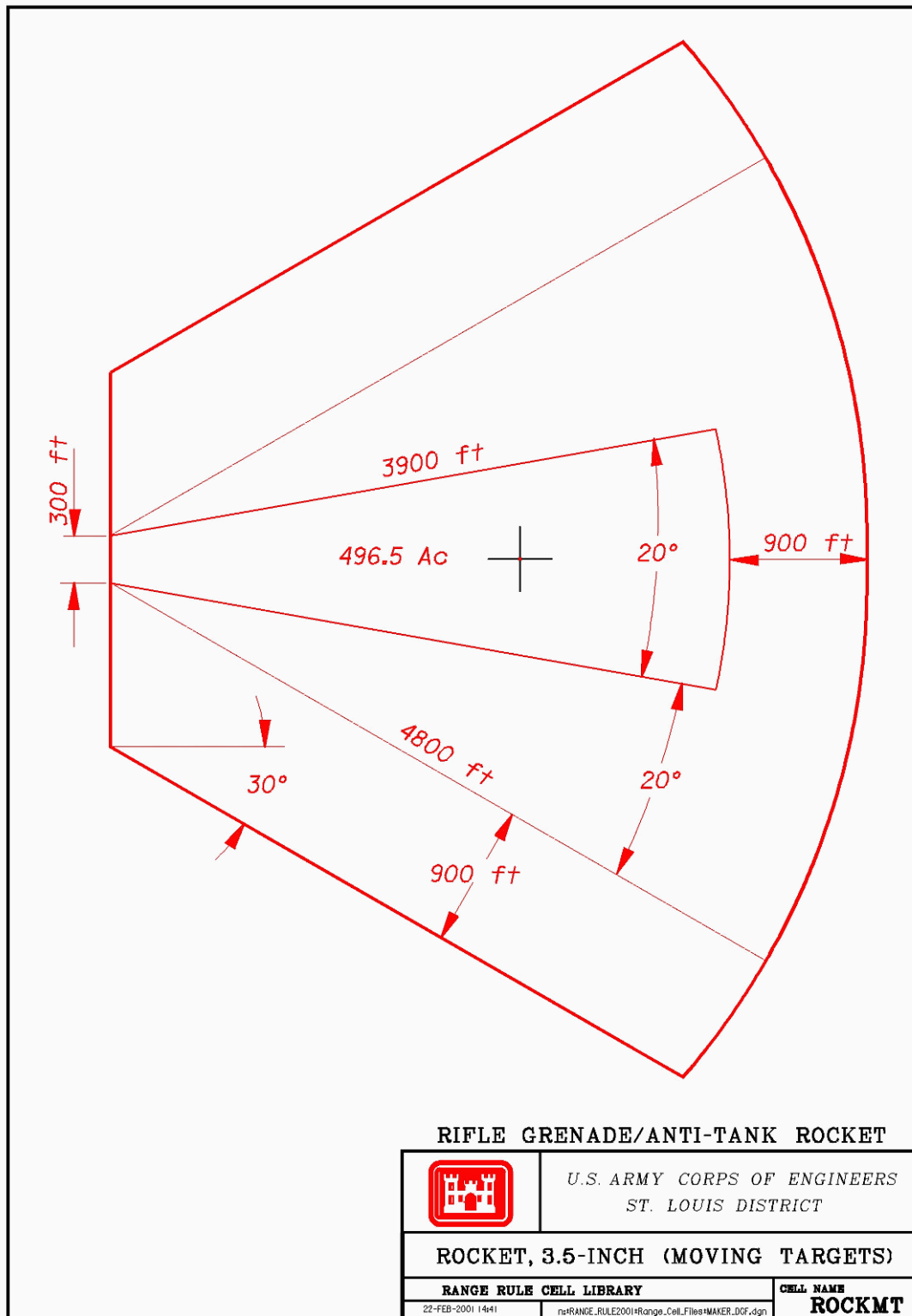

Standard Range Designs

ROCKET, 3.5-inch (STATIONARY TARGETS)

Range Type: Rifle Grenade/Anti-Tank Rocket

Cell Name(s): ROCKST

Target areas would have been established with consideration given to terrain and local restrictions; however, a width of 356 mils (20°) is assumed for this range cell. Targets would have likely been located at 100, 200, and 300 yards, with some down range as far as 650 yards. Typically, targets would have been at least 10 feet square and constructed from paper, cloth, wood, or metal. However, targets would have been constructed of wood or metal when high explosive rockets were used. The impact area would begin at the short limit of the target area (100 yards for this range cell) and extend to the maximum range of the rocket (approximately 1,300 yards for practice rockets). A 20° angle of fire is established by adding 10° to each side of the target area (assumed to be 20° wide). The safety fan includes a 300-yard danger zone beyond the impact area, plus a 300-yard danger zone parallel to the angle of fire that extends the length of the range.

Note: Rifle grenades may be found on these ranges. This range was not available during WWII, but rather sometime around the end of the Korean War.

<u>Ammunition</u>	<u>Max Range (yards)</u>
Rocket, 3.5" Practice	1,300
Rifle Grenade, Practice	400

<u>Ammunition (possible)</u>	<u>Max Range (yards)</u>
Rocket, 3.5" Anti-tank	945
Rocket, 3.5" WP	945
Rifle Grenade, HEAT	400

Data sheet(s):

CTT08	M28, Rocket, HEAT, 3.5" M9A1, Rifle Grenade, Anti Tank
CTT09	M30, Rocket, WP, 3.5"
CTT10	M29, Practice Rocket, 3.5" M11A2, Practice, Rifle Grenade M29, Practice Rifle Grenade

Reference(s): *TM 9-855, Targets, Target Material, and Training Course Lay-outs*, November 1951

Standard Range Designs

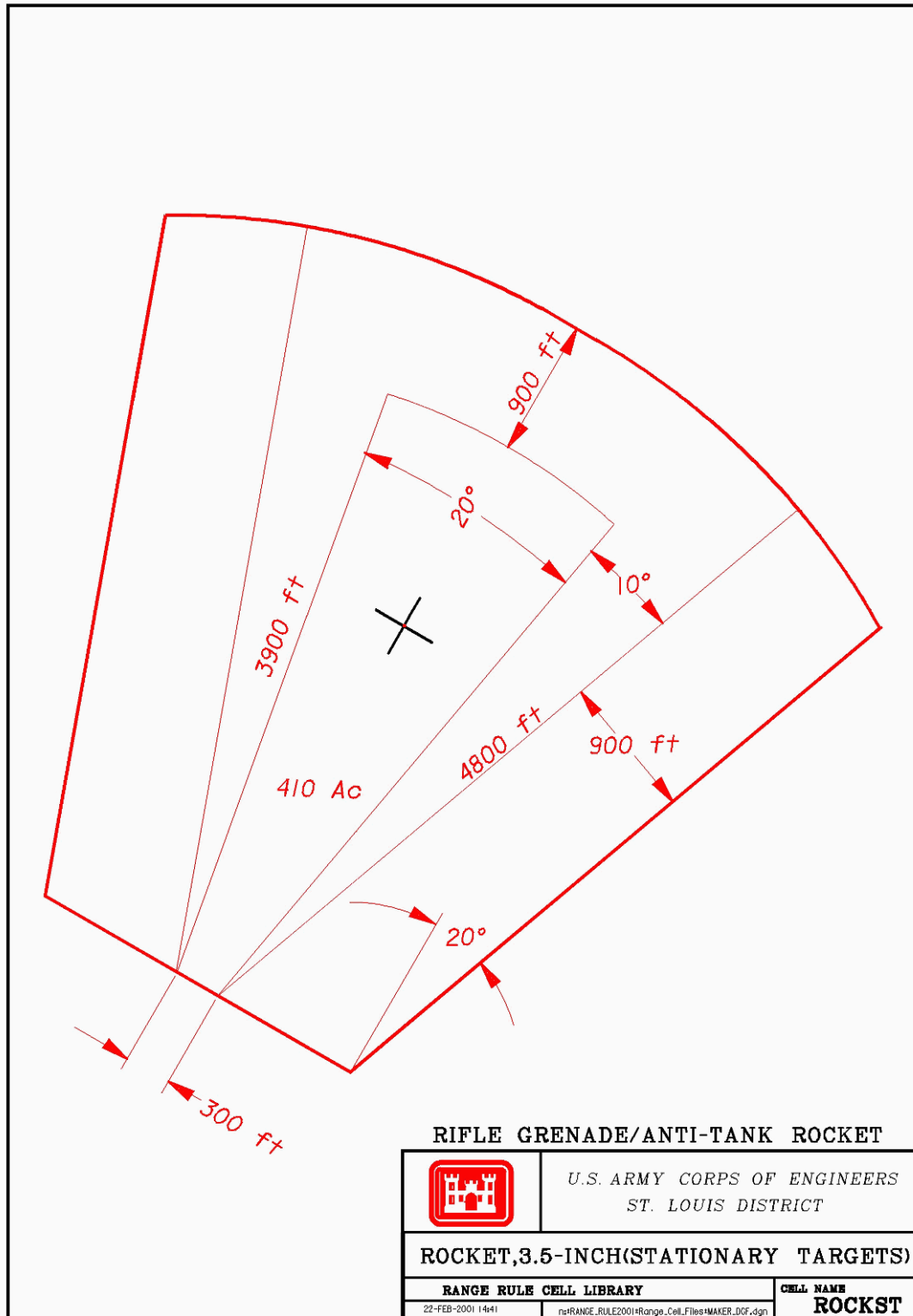

(Source: USACE-St. Louis, 2002)

Standard Range Designs

ROCKET, AIR TO GROUND

Range Type: Air-to-Ground

Cell Name(s): RKTA2G

The range cell was derived using a target area approximately 500 feet by 500 feet. A safety fan of 15° originates from the ends of the 500-foot firing line, which is a minimum of 4,375 yards in front of the target area, and extends 2,734 yards beyond the target area.

It was common for air-to-ground rocket ranges to be co-located within a practice bombing target. Targets may have consisted of derelict vehicles, wooden structures, or merely outlines on the ground.

Information may not be available in which to determine the approach line; therefore, best judgment is necessary when laying out this range cell.

<u>Ammunition (probable)</u>	<u>Max Range (yards)</u>
Aircraft Rockets, Practice	2,000 yards
Aircraft Rockets, Live	2,000 yards

Data sheet(s):

CTT19	3.5-inch, Rocket, Aircraft, Mk4 5-inch, Rocket, HVAR
CTT21	2.25-inch Practice Rocket, Mk6 2.25-inch Practice Rocket, Mk4 2.25-inch Practice Rocket 2.75-inch Practice Rocket, FFAR

Reference(s): AR 385-63, *Policies and Procedures for Firing Ammunition for Training, Target Practice, and Combat*, November 1983

Standard Range Designs

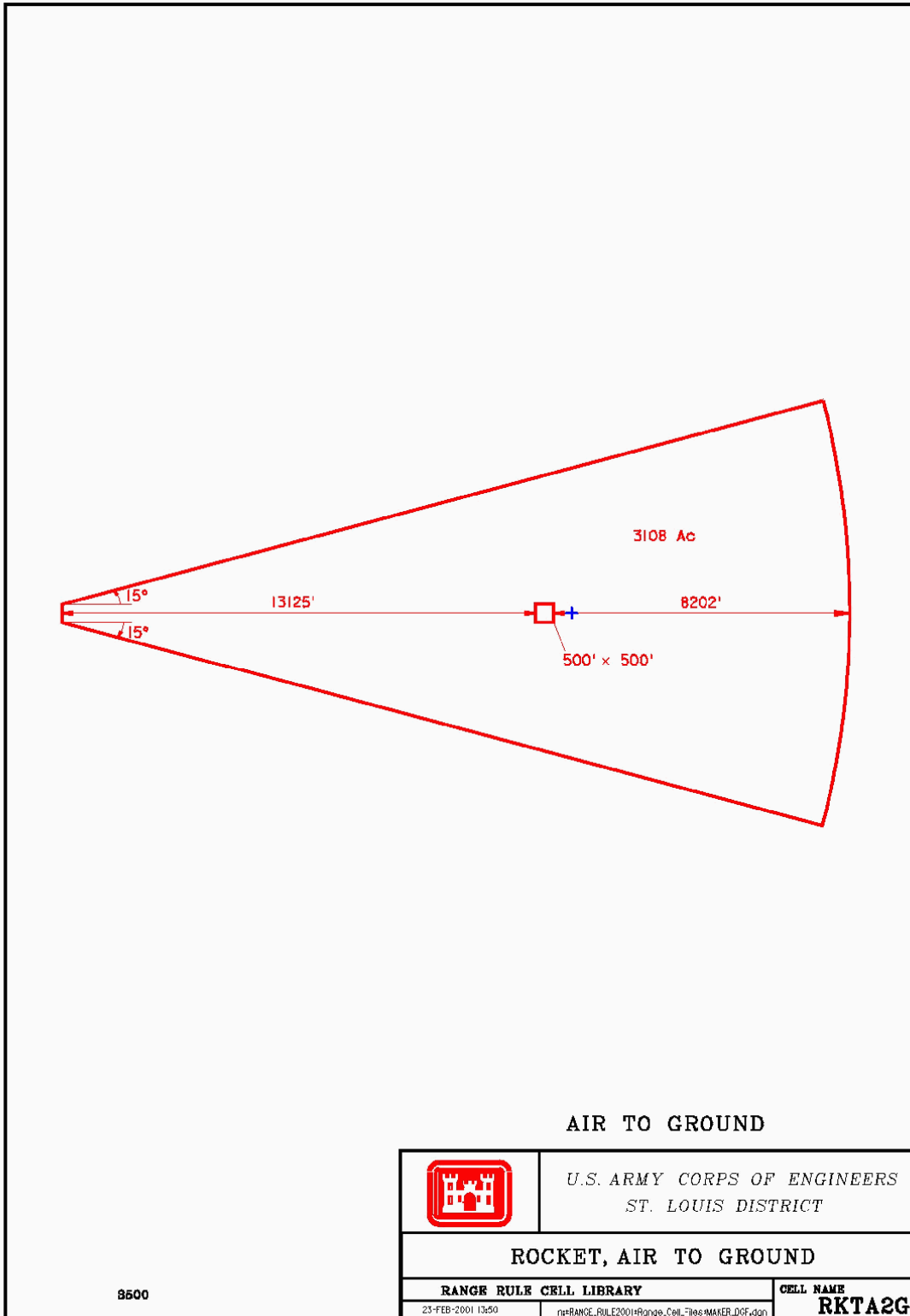

Standard Range Designs

AIR to GROUND GUNNERY

Range Type: Air-to-Ground

Cell Name(s): A2GGUN

The location and size of the air-to-ground gunnery installation will vary considerably with local conditions.

An area of approximately five miles behind the targets, subject to fire and ricocheting bullets, will be designated a danger zone. A safety area in front of the targets will be marked off. A foul line should be clearly marked 600' in front of and parallel to the target line, and a range line should be marked 600' in front of and parallel to the foul line. These two lines should be the length as the target lines or, where only one or two targets are installed on a range, should be of sufficient length to be visible to the pilot from a position directly over them.

Targets should have been of sufficient size to provide a 6' x 6' scoring area. Targets must be placed a minimum of 100' apart. The number of targets on the range will vary, according to space provided.

Extract from the *History of the Army Air Forces Proving Ground Command* – “In ground gunnery, the 6 X 10 targets . . . are attacked from an altitude of 800 feet, at an angle of 30° and an air speed of 150 mph. The attack begins at 1,200 feet, and ends at 600 feet, when an abrupt 90° turn is made, with a shallow climb for recovery. Four planes may fire simultaneously on a range of four targets . . .”

The range cell, which was taken from the referenced letter, was derived using the following assumptions: .30 caliber single gun from P-36 aircraft and At-6 flying at 210 mph and 150 mph, respectively; gun fires at least 600 rounds per minute, uses 50-yard belts, and can fire 50 rounds in a maximum of 5 seconds; a single row of targets located 4,060 feet into the range; and the worst accident that can happen. This worst accident is a runaway gun firing 50 rounds beginning 700 feet from the targets and stopping 800 feet beyond the targets. The range boundary, which is 2.0 miles by 0.5 miles, accounts for this worst accident.

<u>Ammunition (probable)</u>	<u>Max Range (yards)</u>
Small arms	N/A

Data sheet(s):

CTT01 Small arms, General

Reference(s): AAF Manual 85-0-1, *Army Air Forces Gunnery and Bombardment Ranges*, June 1945; Letter from the War Department, Office of the Chief of the Air Corps, addressed to Maj. Partridge, Southeast Air Corps Training Center, dated July 18, 1940; Extract from *History of the Army Air Forces Proving Ground Command, Gunnery Training 1935-1944*

Standard Range Designs

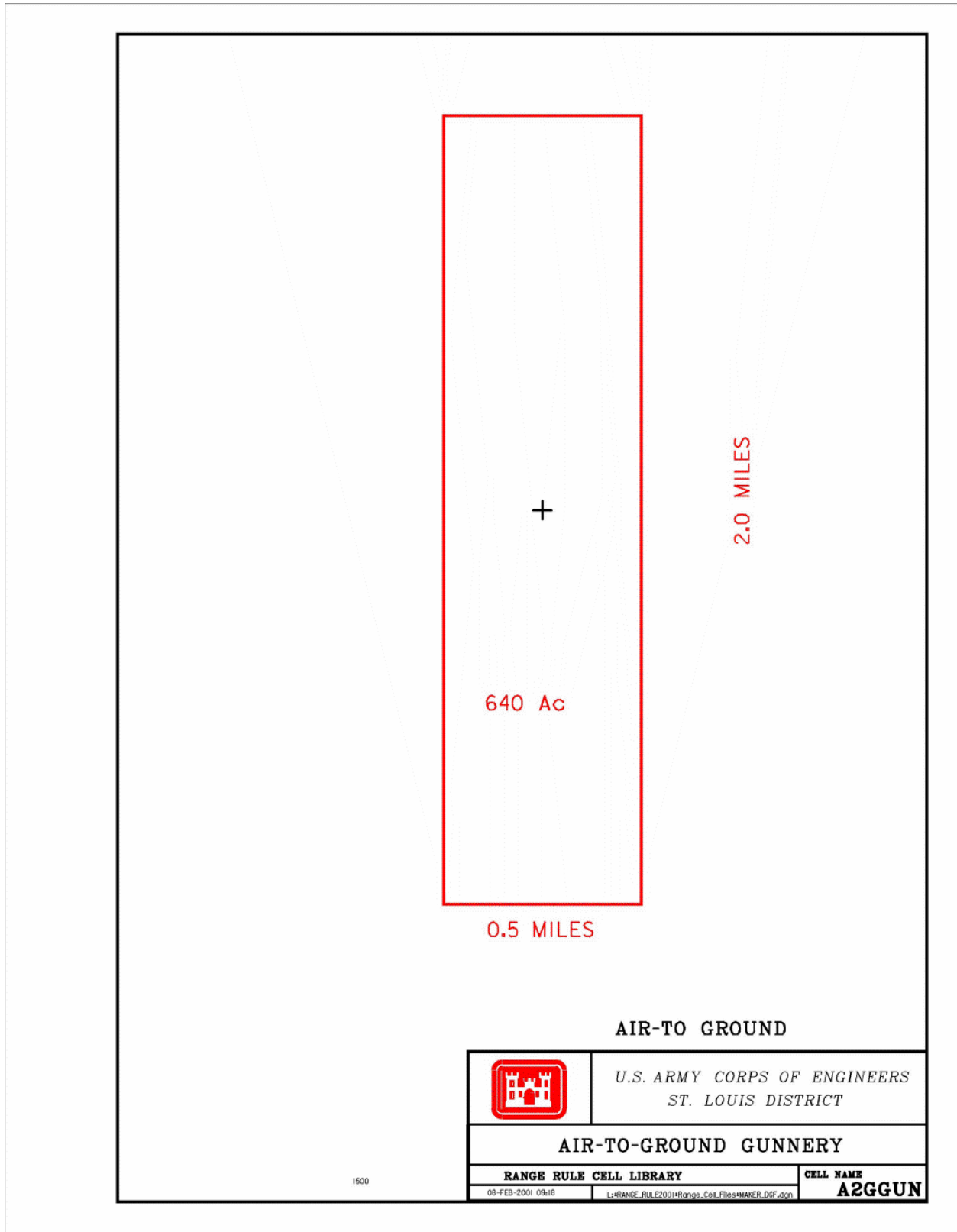

Standard Range Designs

BOMBING TARGET, LIVE

(aka: PBR, Precision Bombing Target, Bombing Range)

Range Type: Bombing

Cell Name(s): BOMB

The Purpose of the range for use with tactical bombs is to familiarize students of handling and releasing combat ammunition.

The range area, adequate for use with 100-lb. demolition bombs below 15,000', will be a minimum of One and one-half miles square with the target located centrally. The target is a cross-shaped ground area scraped free from vegetation and whitewashed. A night target is not used on this type range.

Although OE will be concentrated around the target, evidence of bombing is almost always found beyond the scoring arcs. OE debris is typically found throughout the entire property and occasionally beyond the property boundaries. The range cell area was calculated to extend beyond the target center 3000 feet, for a total of 649 acres. Many factors, all of which are unknown, such as altitude and flight speed, affect targeting accuracy. From studies completed in WWII, 99 percent of the bombs should be found within 3,000 feet for bombers flying at 25,000 feet or below and at speeds up to 250 mph. The same study implied a 2,000-foot radius should include 95 percent of the bombs under the same conditions.

Ammunition (probable)

Bomb, High Explosive

Data sheet(s):

When selecting datasheets, it is important to consider the time frame the range was used.

Possibilities include:

CTT05 Bomb, General Purpose, Old Style
 AN-M30, General Purpose Bomb, 100-lbs
 AN-M57 & AN-M57A1, GP, 250-lbs

Reference(s): *AR 750-10, Range Regulations for Firing Ammunition in Time of Peace*, May 1939 – January 1944; *AAF Manual 85-0-1, Army Air Forces Gunnery and Bombardment Ranges*, June 1945; *Army Air Corps Studies and Reports on Bombing Analysis and Bombing Accuracy*, 1942

Standard Range Designs

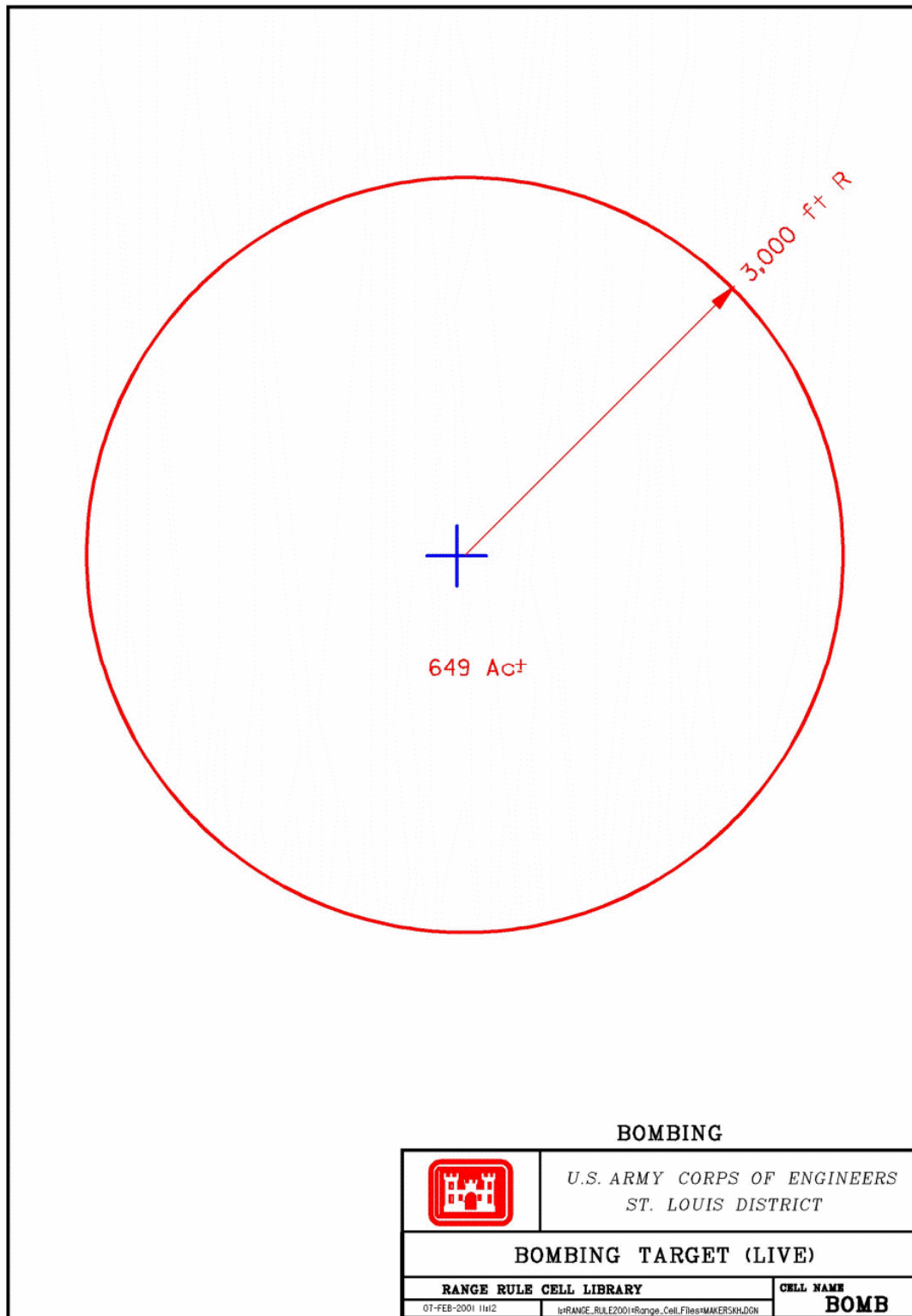

Standard Range Designs

BOMBING TARGET, PRACTICE

(aka: PBR, Precision Bombing Target, Bombing Range)

Range Type: Bombing

Cell Name(s): BOMB (same as Bombing Target, Live)

The range area should be sufficiently large so that the center of any target placed on it will be a minimum of 2500' from the range boundary. For bombing from 25,000' and above, a 5000' radius is advisable.

The typical and widely used target design consists of a series of concentric circles with four legs indicating N/S and E/W in True direction. Four reference squares were placed along each leg at 100' intervals to facilitate scoring. For the purpose of indicating True North, the north leg is extended within the 100' circle towards the target center a distance of 40'. At the extreme end of the north leg, a numeral (75' to 150' in size) is set with its base towards the center of the target. While the 100' circle is an essential feature of the target, the 200' and 500' circles should be described, whenever possible, to facilitate scoring. For bombing above 15,000', it is recommended that only the 200' and 500' circles be described. The legs and circles of the target were constructed of crushed rock or dirt sprayed with white paint, whitewash, or with a contrasting color to the surrounding soil. In the center of the target circle, a pyramid, 12' high with a base approximately 30'x30', is constructed of native earth, or wood, and is whitewashed.

Target lighting was provided by mounting light bulbs on 8' poles, at 22½ feet intervals around the circle. Lights were also mounted at each of the four legs intersecting the 100' circle. Numerals were also illuminated with light bulbs.

Although OE will be concentrated around the target, evidence of bombing is almost always found beyond the scoring arcs. OE debris is typically found throughout the entire property and occasionally beyond the property boundaries. The range cell area was calculated to extend beyond the target center 3000 feet, for a total of 649 acres. Many factors, all of which are unknown, such as altitude and flight speed, affect targeting accuracy. From studies completed in WWII, 99 percent of the bombs should be found within 3,000 feet for bombers flying at 25,000 feet or below and at speeds up to 250 mph. The same study implied a 2,000-foot radius should include 95 percent of the bombs under the same conditions.

Ammunition (probable)

Bomb, Practice

Standard Range Designs

Data sheet(s):

When selecting datasheets, it is important to consider the time frame the range was used.

Possibilities include:

CTT07 AN-Mk 5, AN-Mk 23, AN-Mk 43, Prac
M38A2 Practice Bomb, 100-lbs
M85 Practice Bomb, 100-lbs
Mk 15 Mod 3, Practice Bomb, 100 lbs
Mk 15 series, Practice Bomb, 100 lbs
Mk 5, Mk 15, Mk21, Prac., 500lbs
Spotting Charge, M1A1

Reference(s): *AR 750-10, Range Regulations for Firing Ammunition in Time of Peace*, May 1939 – January 1944; *AAF Manual 85-0-1, Army Air Forces Gunnery and Bombardment Ranges*, June 1945; *Army Air Corps Studies and Reports on Bombing Analysis and Bombing Accuracy*, 1942

Standard Range Designs

DEMONSTRATION BOMBING TARGET, (PRACTICE)

Range Type: Bombing

Cell Name(s): DEMBMB

Demonstration bombing targets were typically utilized for competition and/or public demonstrations. Typically, targets were located adjacent to runways and observation points. Under normal circumstances one can expect bombs to have been released from a relatively low altitude with substantial accuracy. Although OE will be concentrated around the target, evidence of bombing is almost always found beyond the scoring arcs. The Characterization Acreage for this type of bombing target is calculated to extend beyond the target center 1,000 feet, for a total of 72 acres

Ammunition (probable)

Bomb, Practice

Data sheet(s):

When selecting datasheets, it is important to consider the time frame the range was used.

Possibilities include:

CTT07 AN-Mk 5, AN-Mk 23, AN-Mk 43, Prac
M38A2 Practice Bomb, 100 lbs
M85 Practice Bomb, 100 lbs
Mk 15 Mod 3, Practice Bomb, 100 lbs
Mk 15 series, Practice Bomb, 100 lbs
Spotting Charge, M1A1

Reference(s): *AR 750-10, Range Regulations for Firing Ammunition in Time of Peace*, May 1939 – January 1944

Standard Range Designs

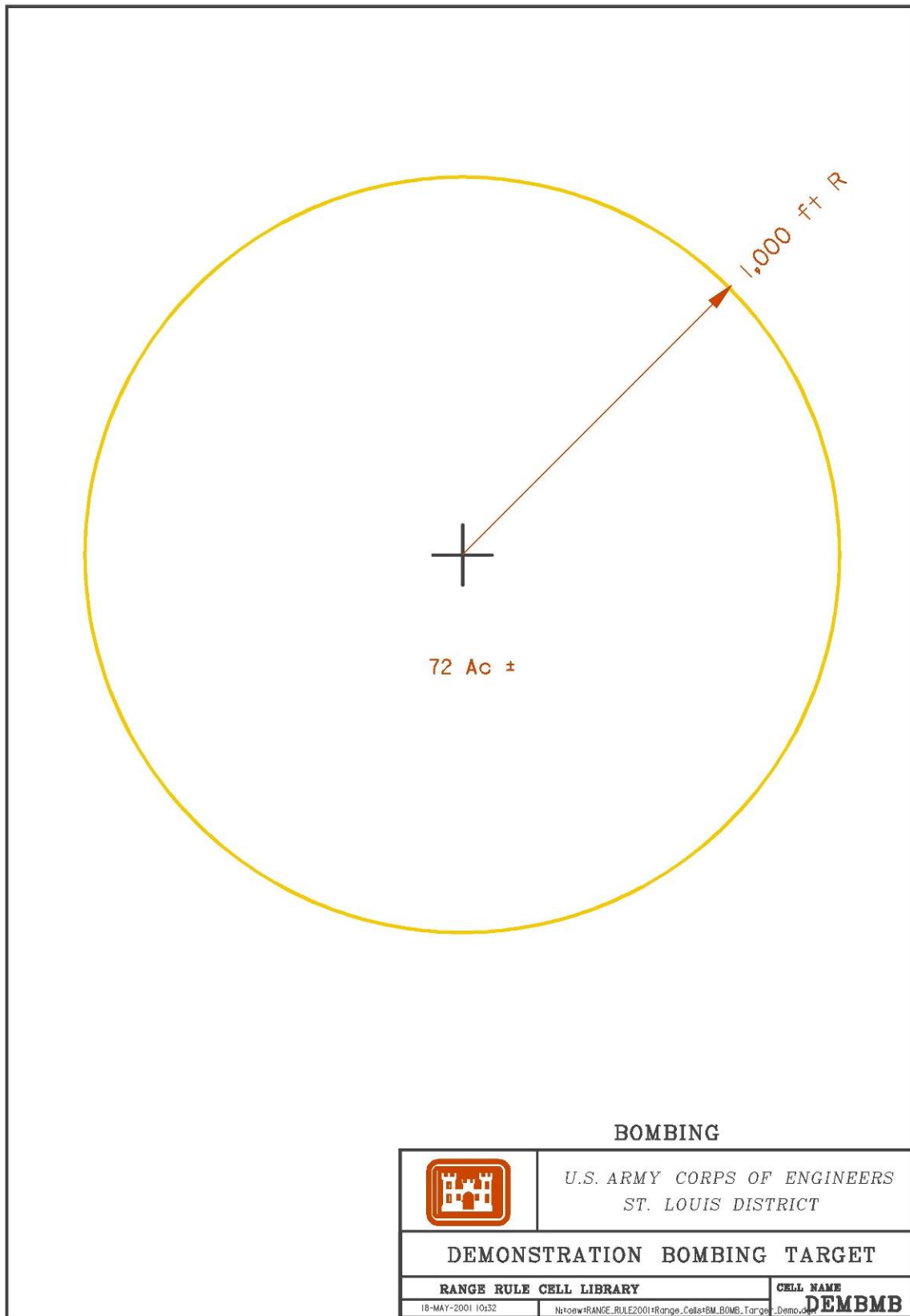

(Source: USACE-St. Louis, 2002)

Standard Range Designs

AIR to AIR

Range Type: Air-to-Air

Cell Name(s): None available

Description, range boundaries, and range layout should be extracted from historical documents. Typically, this type of range covers a very large landmass, in which small arms ammunition is generally used.

The length and width of an air-to-air range was determined by the altitude at which the firing was done. The length of the range also depends upon the true airspeed of the towing aircraft, the types of attacks being made on the target, and the number of aircraft that are to fire on the target at any one time. The following figures are given for firing up to altitudes of 20,000': For training type aircraft, towing at true airspeed up to 150 mph, a firing range 10 miles long is sufficient. For tactical type aircraft, towing up to 200 mph true airspeed, a firing range 15 miles long is advisable. Danger zones will extend at least eight miles beyond each end of the firing range.

For firing above 20,000', the firing range should be at least 20 to 25 miles long with danger zone areas extending at least 10 miles beyond each end of the firing range.

There must be a danger area or restricted area in the direction of fire. This may be designated the width of the range. The dimensions of this area will be determined by the effective range of the ammunition being fired.

All information is based on Caliber .50 machine guns firing to the rear or forward from the aircraft with A.P. M2 ammunition.

Altitude of 30,000', airspeed 450 mph, Rear: 15,500 yds., Forward: 18,300 yds.

Altitude of 30,000', airspeed 150 mph, Rear: 16,700 yds., Forward: 17,600 yds.

Altitude of 20,000', airspeed 450 mph, Rear: 12,350 yds., Forward: 14,450 yds.

Altitude of 20,000', airspeed 150 mph, Rear: 13,250 yds., Forward: 13,900 yds.

Ammunition (probable)

Small arms

Max Range (yards)

N/A

Data sheet(s):

CTT01 Small arms, general

Reference(s): AAF Manual 85-0-1, *Army Air Forces Gunnery and Bombardment Ranges*, June 1945

Standard Range Designs

Standard Range Designs

TRAINING AREAS

There are six different types of training areas: Institutional Area, Garrison Area, Local Training Area, Major Training Area, Range and Impact Area, and National Training Center.

An **Institutional Area** is usually associated with service schools and training centers. But, the division post also has an institutional setting. For example, schools at division posts conduct Primary Noncommissioned Officer Courses (PNCOC), Basic Noncommissioned Officer Co (BNCOC), Primary Leadership Courses (PLC), and NCO Academies. The skills acquired at institutions focus on individual proficiency. Institutional courses cannot be taught at other training areas because they require educational devices, which can only be used cost effectively in the classroom.

A **Garrison Area** includes such things as barracks, dayrooms, motor pools, battalion classrooms, parade fields, and installation warehouse facilities. Garrison training areas are usually controlled by a company or battalion commander. While in the garrison area, soldiers learn by using Soldier's Manuals, Training Extension Courses (TEC), Army Correspondence Courses (ACCP), field manuals, training circulars, simulation devices, and some actual weapons. Garrison training concentrates on individual proficiency. A garrison area requires small amounts of land.

A **Local Training Area** consists of sites close to the garrison area. Usually, these sites are only large enough to conduct training up to the company level. The local training area is normally controlled by the post or division headquarters. Sometimes, individual training takes place in this area; but more often, it is used for the collective training of crew through company units. In many instances, it is at the local training area where the collective training process begins.

The **Major Training Area** is a large site used to train units above company level. As a minimum, the major training area at the division post should be large enough to let battalions meet their ARTEP requirements. The type of training conducted in this area varies with the unit and the characteristics of the training site. However, it usually consists of live fire exercises, unit maneuvers, simulation engagements, and Army Training and Evaluation Program (ARTEP) tasks without troops. Because of the size of the major training area, units may have to travel many miles from their garrison area.

A **Range and Impact Area** is located at the division post where units can fire their major weapon systems, which include armor, anti-armor, infantry, artillery, air defense, and Army air-delivered weapons. The impact area is that portion of the training area contaminated by duds. Because of this, it cannot be used for maneuver training. Munitions that do not explode (SABOT projectiles and small arms rounds) may be used in maneuver areas as long as troops stay out of the safety fan during firing.

National Training Center information can be obtained from the cited reference below.

Reference(s): TC 25-1, *Training Land*, August 1978

Standard Range Designs

Standard Range Designs

COMBAT IN CITIES COURSE (aka: Village, Jungle Village, Mock City, MOUT Site)

Range Type: Training Area / Maneuver Area

Cell Name(s): CCITY, CCI3W

Mock villages may consist of anything from a few grass huts to as much as a small city complete with full size buildings, roads, wells, fountains etc. Facilities were constructed to meet specific training requirements. Regardless of the structures, training was designed for house-to-house fighting. The 3-way approach course permits a 180° field of fire, versus direct fire for the single approach course. Ammunition use was restricted by regulations to M2, cal. .30 or others that do not require a danger area that exceeds 4,000 yards. Training may have included the use of pyrotechnics, booby traps, and land mines.

<u>Ammunition (probable)</u>	<u>Max Range (yards)</u>	<u>Muzzle Velocity (fps)</u>
.45 caliber	1,600	802
.30 caliber	3,450	2,700
.22 caliber	1,500	1,100
Small arms Blanks		
Pyrotechnics		

Data sheet(s):

CTT01 Small arms, General

Pyrotechnic data sheets from this era are not available in the database

Reference(s): AR 750-10, *Range Regulations for Firing Ammunition in Time of Peace*, May 1939 – January 1944; TM 9-855, *Targets, Target Material, and Training Course Lay-outs*, August 1944 & November 1951

Standard Range Designs

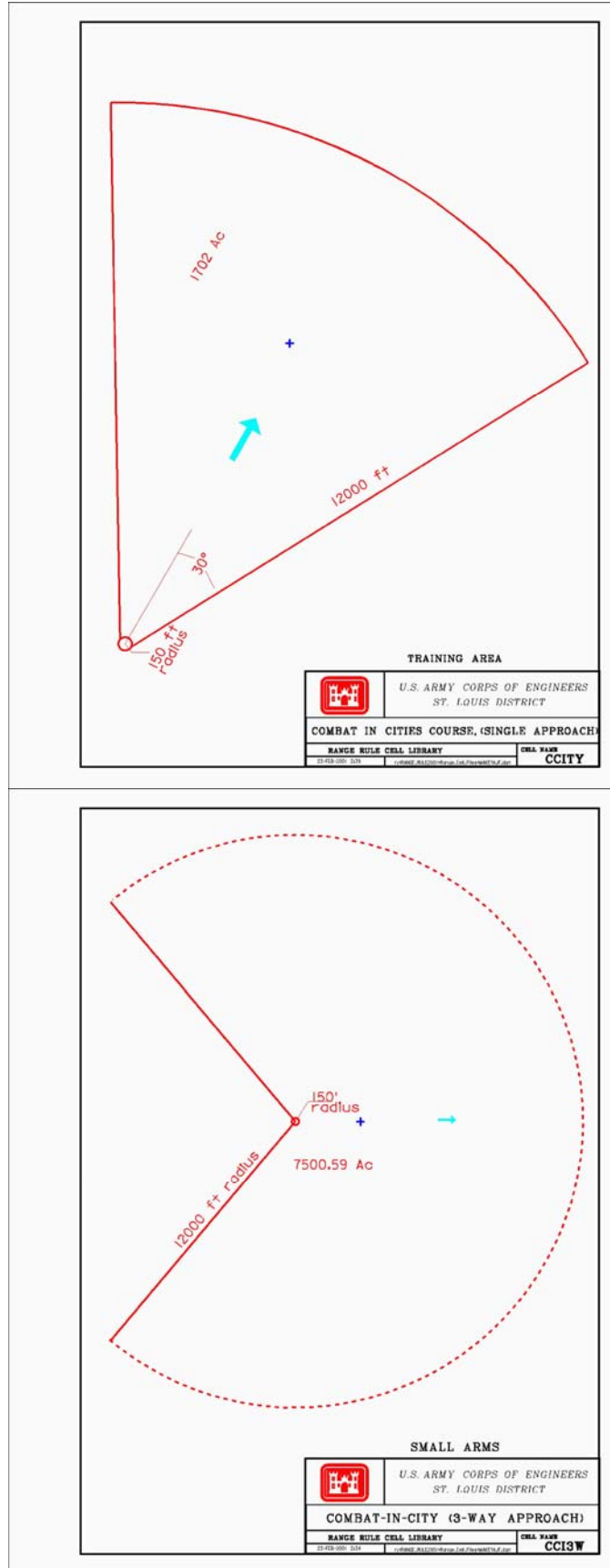

(Source: USACE-St. Louis, 2002)

Standard Range Designs

CAVE

Range Type: Training Area / Maneuver Area

Cell Name(s): None available

Training areas are established locally to meet specific requirements. They typically utilize available terrain features such as natural caves to simulate mountain type fortifications. No available references describe these areas. The description of this training area should come from historical documents relating to this site. Therefore, the boundaries delineated on historical maps should be used in lieu of a standard range cell.

It is speculated that practice munitions would have been used on an area such as this. All weapons available to the infantry may have been utilized. These would have included: small arms, rockets, mortars, rifle grenades, hand grenades, and flame-throwers.

<u>Ammunition (probable)</u>	<u>Max Range (yards)</u>
Small Arms, Blanks	N/A
Rocket, 2.36", Practice	700
Rifle Grenade, Practice	< 400
60mm, Training	350
60mm, Practice	1,935
81mm, Training	350
81mm, Practice	3,300
Practice Hand Grenades	N/A
Pyrotechnics	N/A
Flame Thrower	N/A

Data sheet(s):

CTT01	Small arms, General
CTT04	M21, Practice Hand Grenade Mk1A1 Training Hand Grenade
CTT10	M7A1 Practice Rocket, 2.36" M112A2 Practice Rifle Grenade
CTT18	60mm, Training, M69 60mm, Practice, M50A2 81mm, Training, M68 81mm, Practice, M43A1

Pyrotechnic data sheets from this era are not available in the database

Reference(s): No references available

Standard Range Designs

Standard Range Designs

PILL BOX

Range Type: Training Area / Maneuver Area

Cell Name(s): None available

In general, the training area consists of a single or multiple concrete fortifications, commonly referred to as pillboxes. The area may be a 10-foot by 10-foot concrete box or a large concrete gun emplacement on the side of mountain. No available references describe these areas. The description of this training area should come from historical documents relating to this site. Therefore, the boundaries delineated on historical maps should be used in lieu of a standard range cell.

It is assumed that practice munitions would have been used on an area such as this. All weapons available to the infantry may have been utilized. These would have included: small arms, rockets, mortars, rifle grenades, hand grenades, and flame-throwers.

<u>Ammunition (probable)</u>	<u>Max Range (yards)</u>
Small Arms, Blanks	N/A
Rocket, 2.36", Practice	700
Rifle Grenade, Practice	< 400
60mm, Training	350
60mm, Practice	1,935
81mm, Training	350
81mm, Practice	3,300
Practice Hand Grenades	N/A
Pyrotechnics	N/A
Flame Thrower	N/A

Data sheet(s):

CTT01	Small arms, General
CTT04	M21, Practice Hand Grenade Mk1A1 Training Hand Grenade
CTT10	M7A1 Practice Rocket, 2.36" M112A2 Practice Rifle Grenade
CTT18	60mm, Training, M69 60mm, Practice, M50A2 81mm, Training, M68 81mm, Practice, M43A1

Pyrotechnic data sheets from this era are not available in the database.

Reference(s): No references available

Standard Range Designs

Standard Range Designs

BURN AREA

Range Type: OB/OD

Cell Name(s): BURNAR

The range is typically used to destroy unserviceable small arms ammunition, pyrotechnics, propellants, and explosives.

A danger area is established by application of the criteria given below.

If the net explosive weight (NEW) of burn material is more than 100 pounds the minimum safe distance shall be at least 1,250 feet. If the NEW of burn material is 100 pounds or less, the danger area shall be at least 670 feet.

If the facility is a military range and the material being destroyed is unknown consider the NEW to be 100 pounds or less and select a danger area of 670 feet.

If the facility is an ammunition plant or explosive manufacturing plant assume the danger area to be a minimum of 1,250 feet unless evidence indicates a lesser distance is applicable.

Unless the location of the actual burn pit is known, the danger area should be established from all edges of the working area the range.

Ammunition (probable)

Small Arms ammunition, or applicable munitions

Data sheet(s):

When selecting datasheets, it is important to consider the time frame the range was used.

Possibilities include:

CTT01 Small arms, General

Reference(s): DOD 6055.9-STD, *DOD Ammunition and Explosives Safety Standards*, July 1999

Standard Range Designs

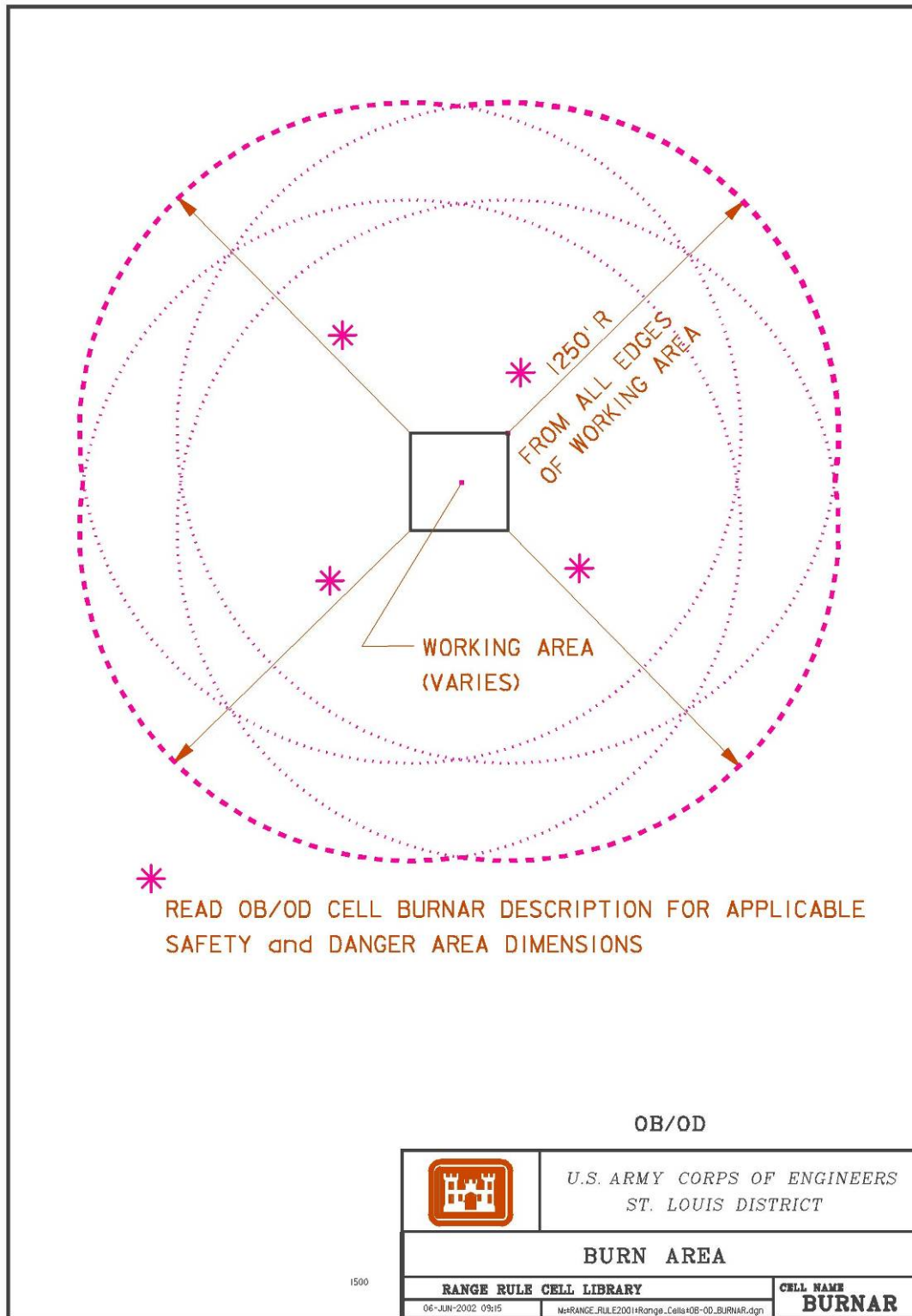

Standard Range Designs

RANGE USED FOR DESTRUCTION OF AMMUNITION, DEMONSTRATIONS, AND EXPLOSIVE ORDNANCE DISPOSAL (EOD)

Range Type: OB/OD

Cell Name(s): EODRNG

The danger area for explosive demolitions, demonstrations, and EOD explosives operations is determined by application of the criteria given below.

The danger area should not be less than 1250 feet, for non-fragmenting explosive materials. This would generally pertain to explosive demonstrations, training, etc.

The danger area should not be less than 2500 feet, for fragmenting explosive materials. For bombs and projectiles with caliber 5-inches or greater use a minimum distance of 4000 feet.

If the type of ammunition destroyed on the range is unknown then the maximum distance should be applied.

Because the actual disposal pits may be positioned anywhere within the range area, the danger area should be established from all edges of the working area of the range.

Ammunition (probable)

All ammunition, applicable to the installation. To include demolition materials.

Data sheet(s):

Must be determined for each site

Reference(s): DOD 6055.9-STD, *DOD Ammunition and Explosives Safety Standards*, July 1999

Standard Range Designs

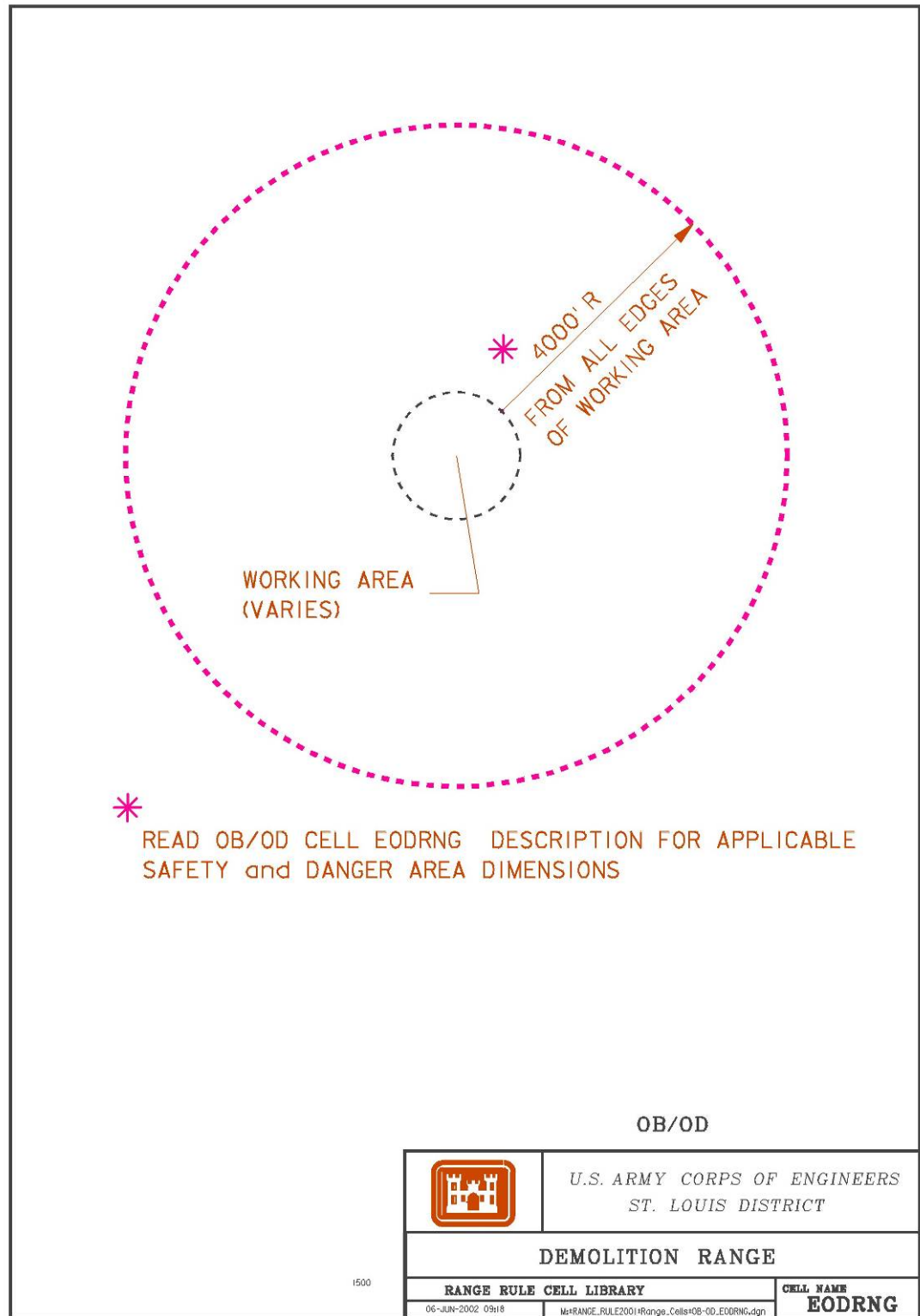

Appendix E—Ordnance Images

Range Types

Direct Fire

Indirect Fire

Bombing and Gunnery

This appendix includes selected images of ordnance types that have been found on several closed ranges. The source of the images is the ORDATA II database that was produced by the Naval Explosive Ordnance Disposal Technology Division to support the U.S. Department of Defense Humanitarian Demining Program. It provides information for international demining/clearance personnel engaged in identification, recovery and disposal of unexploded ordnance (UXO).

Most of the images presented here show the ordnance items in their original, unused form along with diagrams of their major dimensions. Note that these images may include components that would not be present after firing. The ordnance types are organized by the probable type of range where they would have been used. However, past history has shown that ordnance of almost any type can show up on almost any range type.

Source: NAVEODTECHDIV, 1999. ORDATA II, Enhanced International Deminer's Guide to UXO Identification, Recovery, and Disposal, Naval Explosive Ordnance Disposal Technology Division, Indian Head, MD, January 1999 (<http://www.maic.jmu.edu/ordata>).

E.1 ORDNANCE IMAGES - DIRECT FIRE

Table E-1. Direct Fire Ordnance Examples

Category	Type	Purpose	Model Series	Diameter (mm)	ORDATA II ID	
Grenade	Hand	Fragmentation	Mk2	57	887	
			M67	64	891	
			Practice	Mk1A1	57	3843
		Practice	Mk2	57	3845	
			M21		5955	
			M30; M62	57	6144	
			M69	64	5956	
			Illumination	Mk1	53	3017
			Incendiary	TH3, AN-M14	64	3024
	Smoke	AN-M8, HC	62	881		
		M18 Series	64	878		
		Rifle	Fragmentation	M9 Series	57	900
	M17			57	801	
	HEAT		M9A1; M9A2	57	797	
	Practice		M11 Series	57	800	
Smoke	M22 Series		51	829		
Projectile	20 mm		HE	Mk3	20	5311
		M97 Series		20	3010	
	22 mm Subcal	Practice	M744	22	2684	
	37 mm	AP-T	M51 Series	37	6352	
		HE	M54; M54A1	37	6339	
	40 mm	HE	M381	40	245	
		Practice	M382; M407A1	40	254	
			M781	40	451	
			M918	40	249	
	57 mm	AP-T	M70	57		
		APDS-T	M392 Series	57	505	
		HE	M303	57	504	
			M306 Series	57	2881	

Source: NAVEODTECHDIV, 1999, ORDATA II

ORDNANCE IMAGES - DIRECT FIRE

Table E-1. Direct Fire Ordnance Examples (Concluded)

Category	Type	Purpose	Model Series	Diameter (mm)	ORDATA II ID
Rocket	35 mm Subcal	Practice	M73	35	383
		HEAT	M6 Series	60	657
	2.36 INCH	Practice	M7 Series	60	
		Incen	T31	60	3528
		LAW	M72 Series	66	408
	66 mm	Incendiary	M74	66	496
		3.5 INCH	HEAT	M28	89
	Practice		M29 Series	89	6157
Guided Missile	Dragon	HEAT	M222	122	2552
		Practice	M223 & M231	122	
Signal	ILLUM	Aircraft	AN-M43 Series	39	3652
		Ground	M125A1, M158, M159; M126A1, M127A1, M195 & M207	42	2235
			RED STAR M126A1, WHITE STAR M127A1	42	7334
			Parachute, Rifle	M17 Series (M17A1)	41
		M2	38	3696	
Flare	Trip		M48	64	5411
			M49	64	3757

ORDNANCE IMAGES - DIRECT FIRE

HAND GRENADES

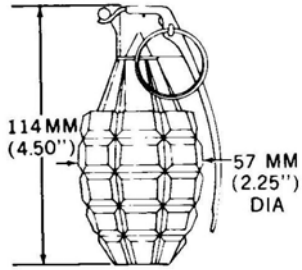

DIMENSIONAL VIEW



Grenade, Hand, Fragmentation, Mk 2; (Practice, Mk1A1)

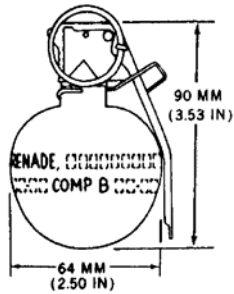

Grenade, Hand, Fragmentation, M67

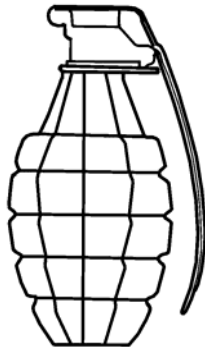

Grenade, Hand, Practice, Mk2

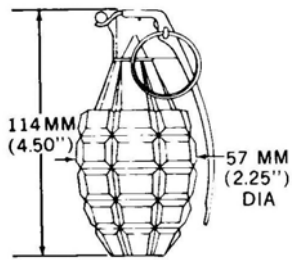

DIMENSIONAL VIEW



Grenade, Hand, Practice, M21

ORDNANCE IMAGES - DIRECT FIRE

HAND GRENADES

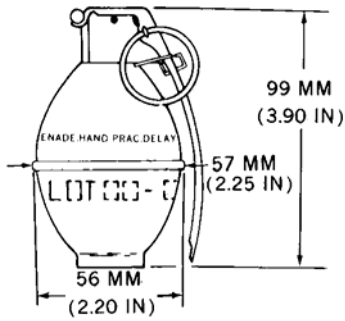

Grenade, Hand, Practice, M30; M62

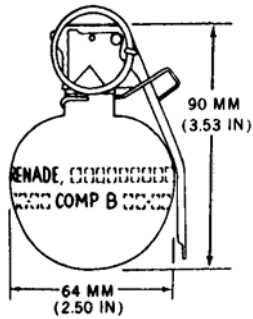

Grenade, Hand, Practice, M69

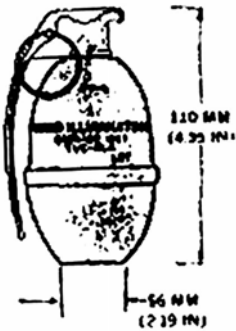

Grenade, Hand, Illuminating, Mk 1

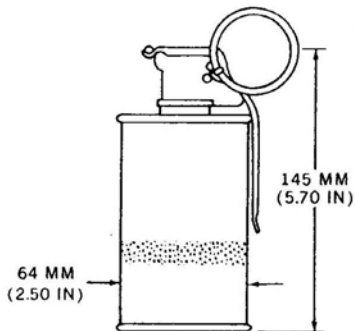

Grenade, Hand, Incendiary, Th3, An-M14

ORDNANCE IMAGES - DIRECT FIRE

HAND GRENADES

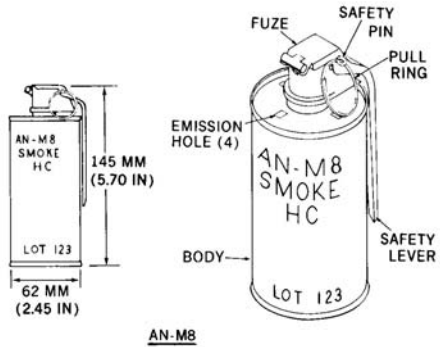

AN-M8



Grenade, Hand, Smoke, AN-M8, HC

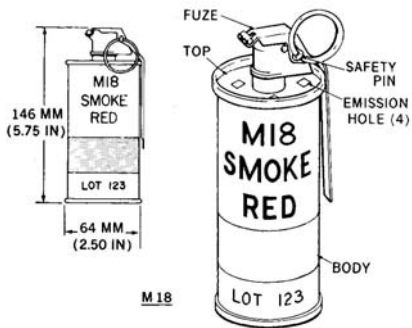

M18



Grenade, Hand, Smoke, M18

ORDNANCE IMAGES - DIRECT FIRE

RIFLE GRENADES

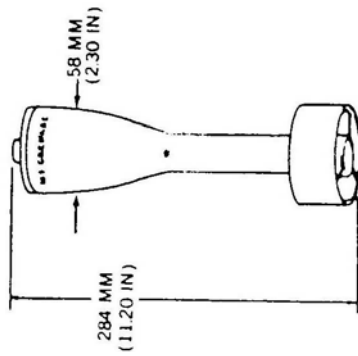

Grenade, Rifle, Fragmentation, M9

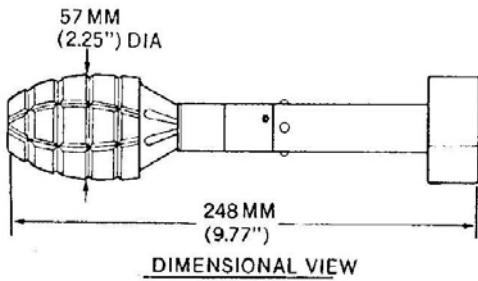

Grenade, Rifle, Fragmentation, M17

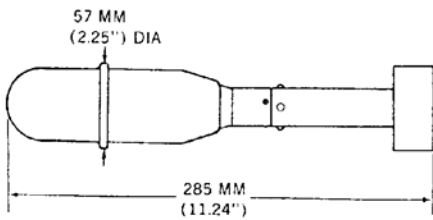

Grenade, Rifle, HEAT, M9A1; M9A2

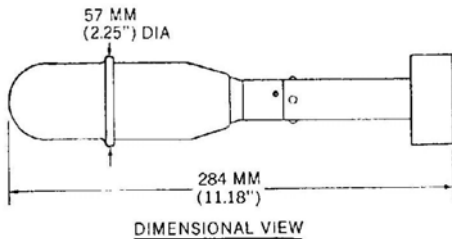

Grenade, Rifle, Practice, M11 Series

ORDNANCE IMAGES - DIRECT FIRE

RIFLE GRENADES

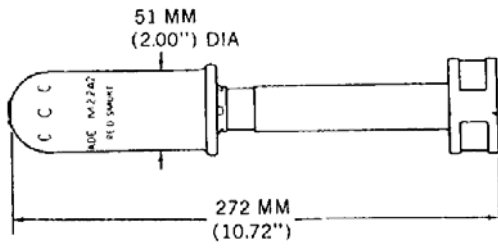

DIMENSIONAL VIEW

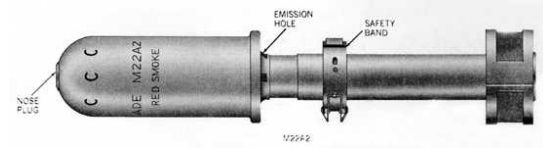

Grenade, Rifle, Smoke, M22 Series

ORDNANCE IMAGES - DIRECT FIRE

PROJECTILES

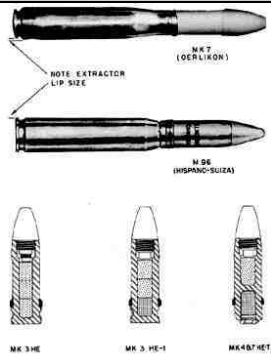

Projectile, 20 mm, HE, Mk3

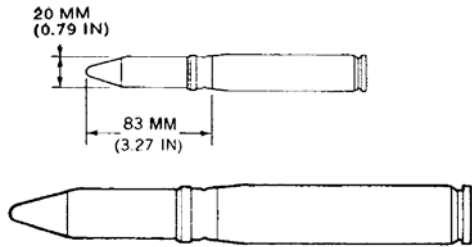

Projectile, 20 mm, HE, M97 Series

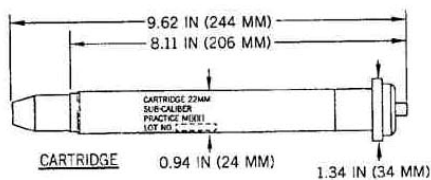

Projectile, 22 Subcal, Practice, M744

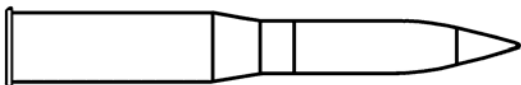

Projectile, 37 mm, AP-T. M51 Series

ORDNANCE IMAGES - DIRECT FIRE

PROJECTILES

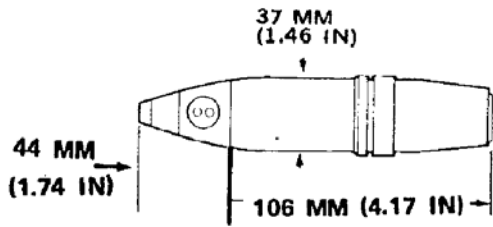

Projectile, 37 mm, HE, M54; M54A1

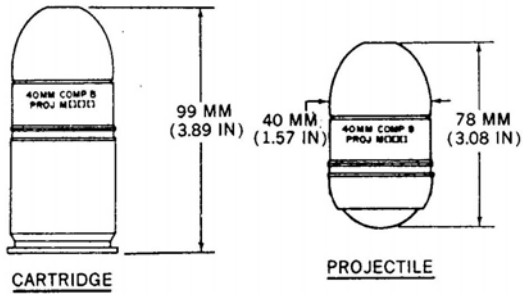

Projectile, 40 mm, HE, M381

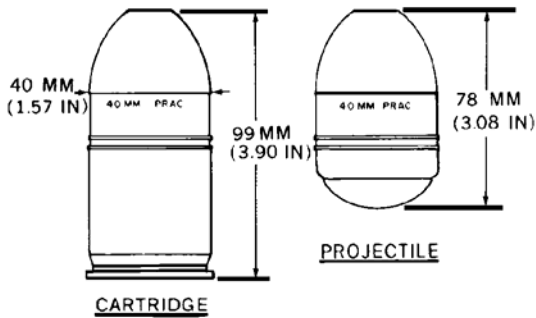

Projectile, 40 mm, Practice, M382; M407A1

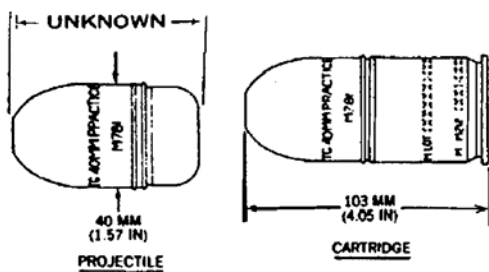

Projectile, 40 mm, Practice, M781

ORDNANCE IMAGES - DIRECT FIRE

PROJECTILES

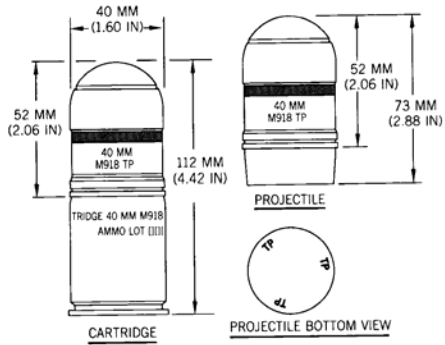

Projectile, 40 mm, Practice. M918

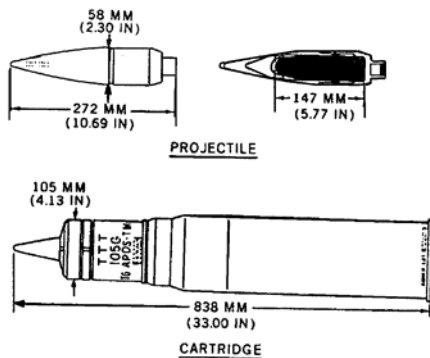

Projectile, 57 mm, APDS-T. M392 Series

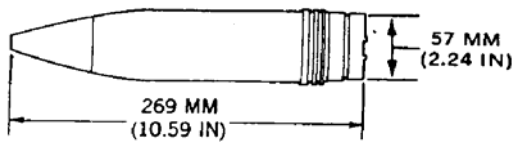

Projectile, 57 mm, HE. M303

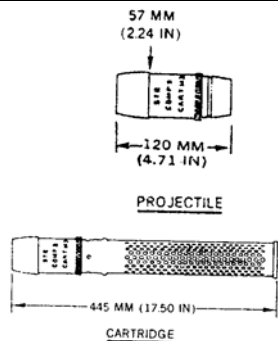

Projectile, 57 mm, HE. M306 Series

ORDNANCE IMAGES - DIRECT FIRE

ROCKETS

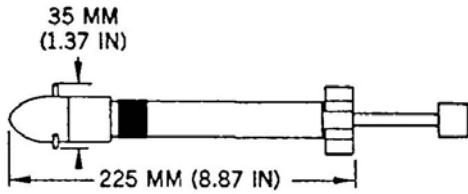

Rocket, 35 mm Subcal, Practice. M73

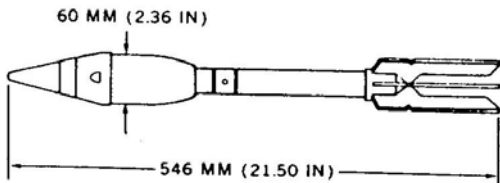

Rocket, 2.36-inch, HEAT. M6 Series

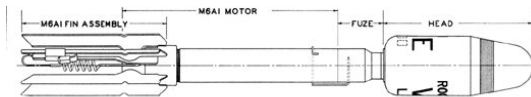

Rocket, 2.36-inch, Incendiary. T31

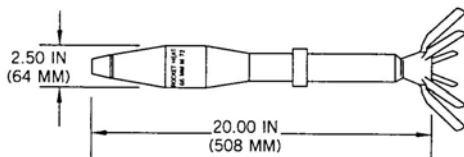

Rocket, 66 mm, LAW. M72 Series

ORDNANCE IMAGES - DIRECT FIRE

ROCKETS

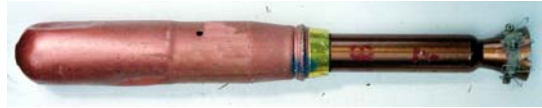
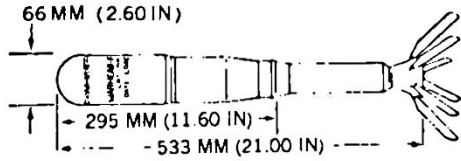

Rocket, 66 mm, Incendiary. M74

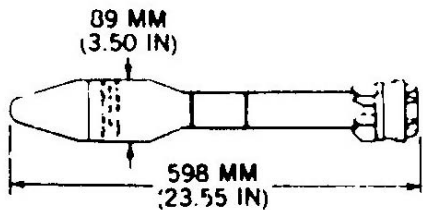

Rocket, 3.5-inch, HEAT. M28

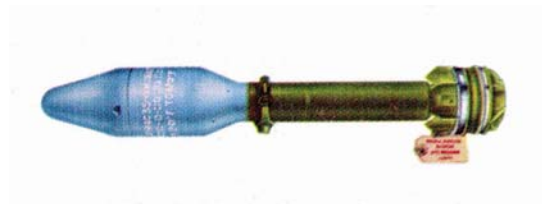
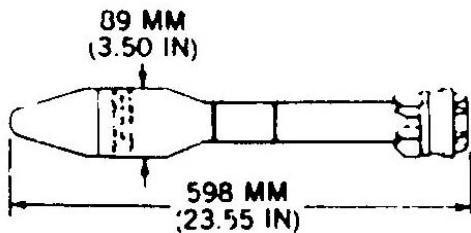

Rocket, 3.5-inch, Practice. M29 Series

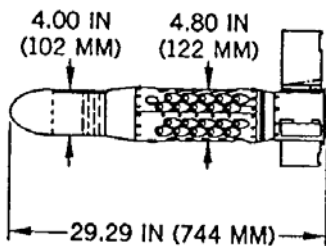

M222, M223 AND M231

Guided Missile, Dragon, M222 (HEAT); M223 & M231 (Practice)"

ORDNANCE IMAGES - DIRECT FIRE

SIGNALS AND FLARES

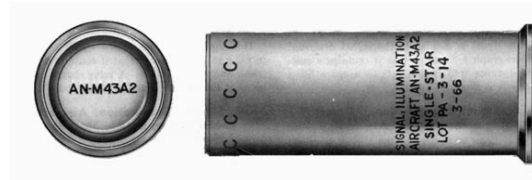
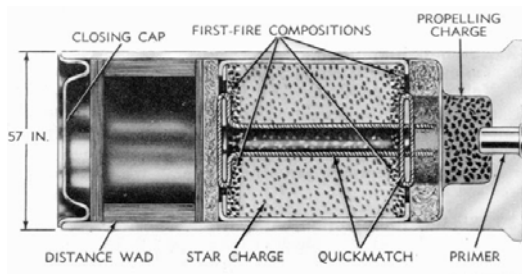

Signal, Illumination, Aircraft. AN-M43 Series

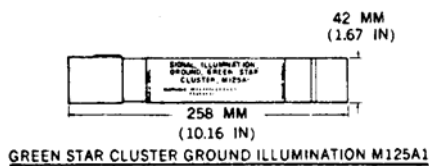

GREEN STAR CLUSTER GROUND ILLUMINATION M125A1

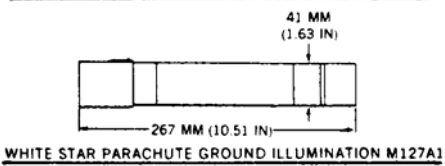
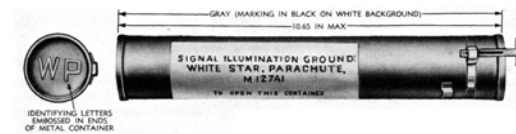

WHITE STAR PARACHUTE GROUND ILLUMINATION M127A1

Signal, Illumination, Ground. RED STAR M126A1, WHITE STAR M127A1, M158; M195; M207, M159

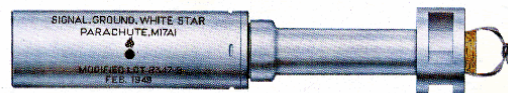
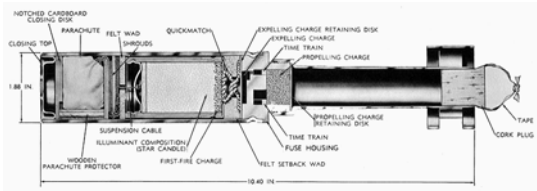

Signal, Illumination, Parachute, Rifle. M17 Series (M17A1)

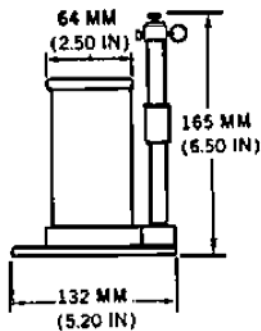

Flare, Trip. M48



E.2 ORDNANCE IMAGES - INDIRECT FIRE

Table E-2. Indirect Fire Range Ordnance Examples

Category	Type	Purpose	Model Series	Diameter (mm)	ORDATA II ID
Mortar	3-inch Stokes	HE	Mk1	76	154
		Practice	Mk1	76	6127
	4.2-inch	HE	M3; M3A1	107	574
		Illumination	M335 Series	107	354
	50 mm, Japanese	HE	"Knee Mortar", Type 89	50	4251
	60 mm	HE	M49 Series	60	628
		Practice	M50 Series	60	625
		Training	M69	60	414
		Illumination	M721	60	193
	81 mm	HE	M83 Series	60	6334
			M43 Series	81	6304
		Practice	M56	81	434
			M43 Series	81	6328
		Training	M68	81	421
		Illumination	M301 Series	81	216
	Projectile	75 mm	HE	M48	75
HEAT			M66	75	3027
Smoke			M64	75	3025
Shrapnel			Mk1	75	6358
90 mm		HE	M71	90	2961
		HEAT-T	M431	90	302
		Practice	M371	90	305
105 mm		HE	M1	105	547
		HE	M413	105	316
		HEAT	M67	105	2979
		Training	M67	105	2965
		Smoke	M84	105	394
155 mm		HE	M107	155	593
		Practice	M101	155	2994
		Smoke	M105	155	721
8-inch		HE	M106	203	608

Source: NAVEODTECHDIV, 1999, ORDATA II

ORDNANCE IMAGES - INDIRECT FIRE

MORTARS

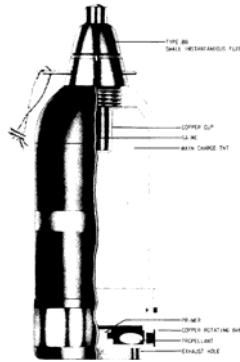

Mortar, 50 mm, Japanese, HE. "Knee Mortar", Type 89

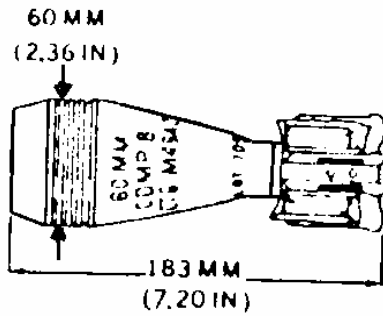

Mortar, 60 mm, HE. M49 Series

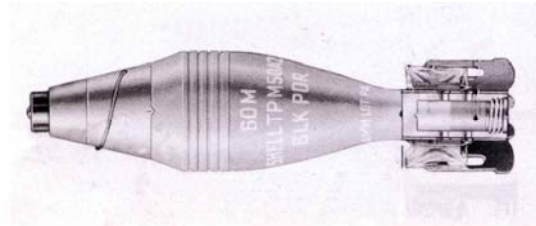
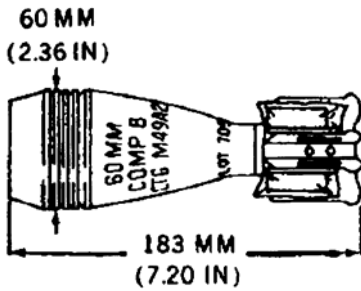

Mortar, 60 mm, Practice. M50 Series

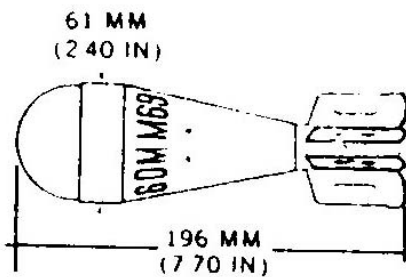

Mortar, 60 mm, Training. M69

ORDNANCE IMAGES - INDIRECT FIRE

MORTARS

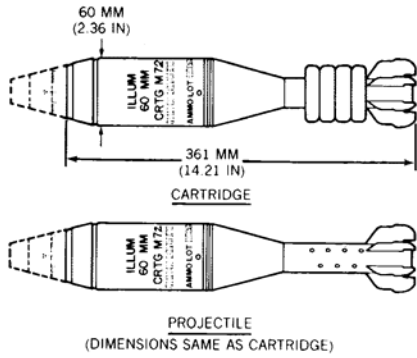

Mortar, 60 mm, Illumination. M721

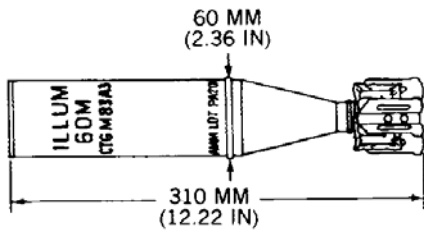

Mortar, 60 mm, . M83 Series

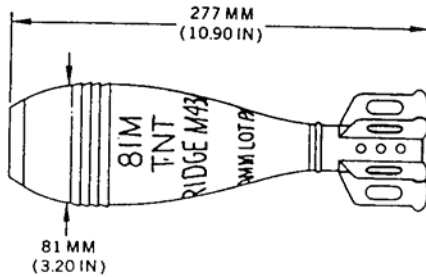

Mortar, 81 mm, HE. M43 Series

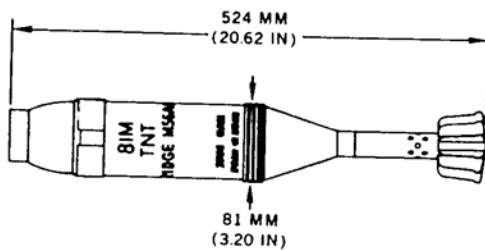

Mortar, 81 mm, . M56

ORDNANCE IMAGES - INDIRECT FIRE

MORTARS

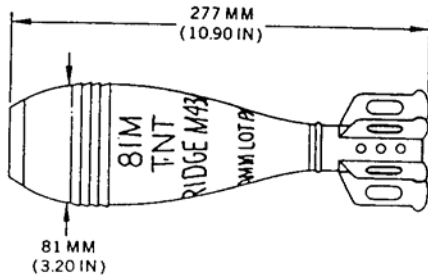

Mortar, 81 mm, Practice. M43 Series

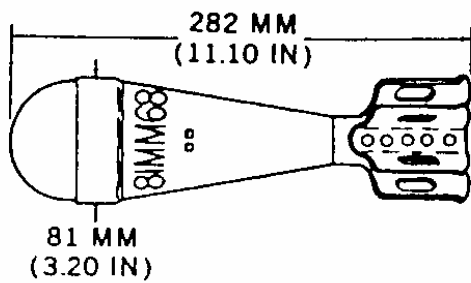

Mortar, 81 mm, Training. M68

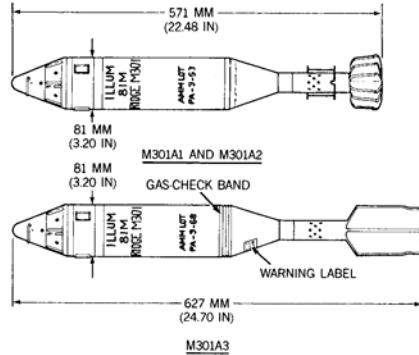

Mortar, 81 mm, Illumination. M301 Series

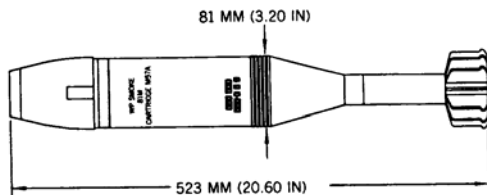

Mortar, 81 mm, Smoke. M57 Series (WP)

ORDNANCE IMAGES - INDIRECT FIRE

PROJECTILES

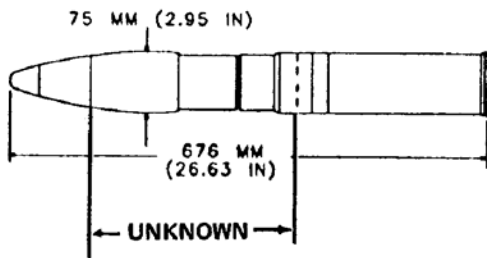

Projectile, 75 mm, HE. M48

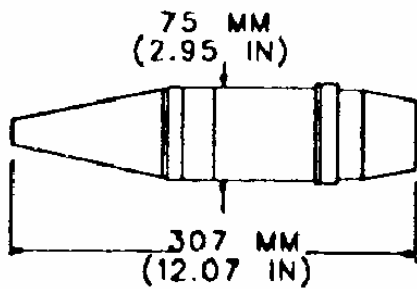

Projectile, 75 mm, HEAT. M66

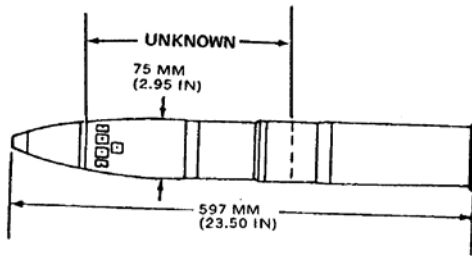

Projectile, 75 mm, Smoke. M64



Projectile, 75 mm, Shrapnel. Mk1

ORDNANCE IMAGES - INDIRECT FIRE

PROJECTILES

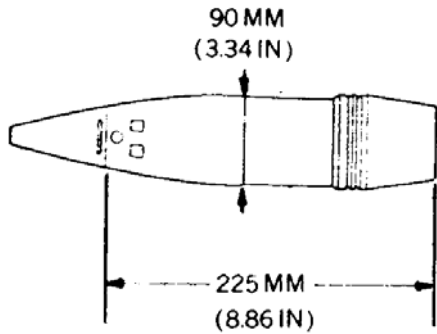

Projectile, 90 mm, HE. M71

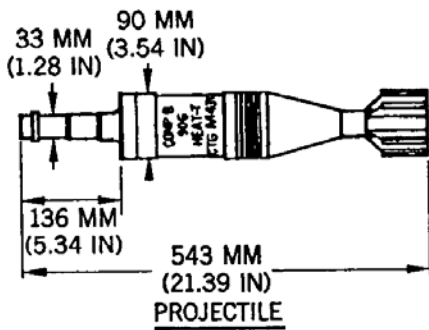

Projectile, 90 mm, HEAT-T. M431

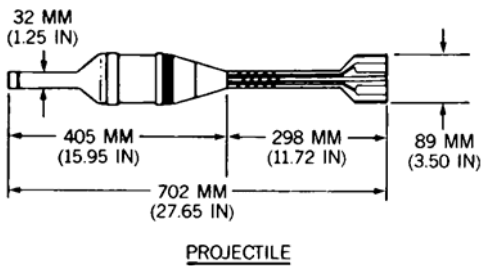

Projectile, 90 mm, Practice. M371

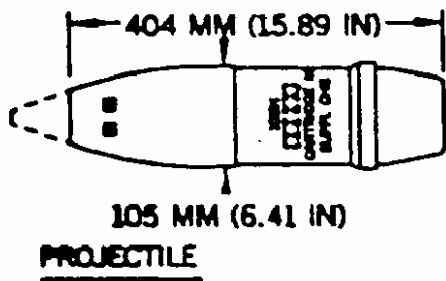

Projectile, 105 mm, HE. M1

ORDNANCE IMAGES - INDIRECT FIRE

PROJECTILES

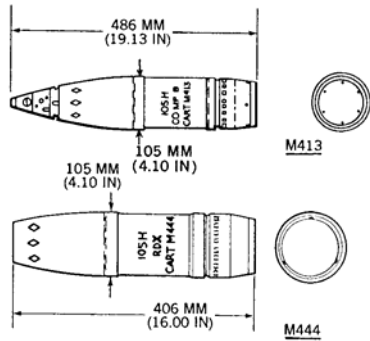

Projectile, 105 mm, HE. M413

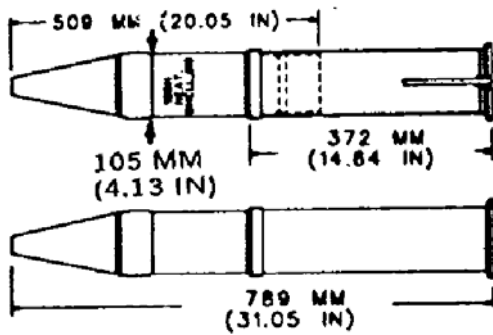

Projectile, 105 mm, HEAT & TP. M67

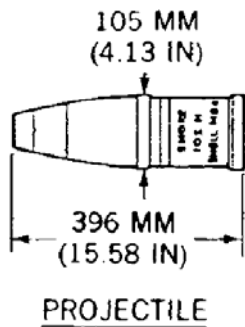

Projectile, 105 mm, Smoke. M84

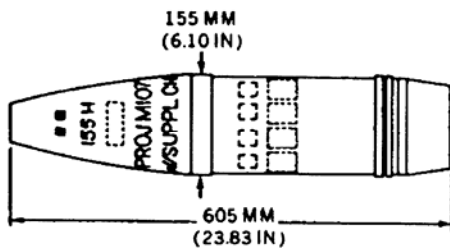

Projectile, 155 mm, HE. M107

ORDNANCE IMAGES - INDIRECT FIRE

PROJECTILES

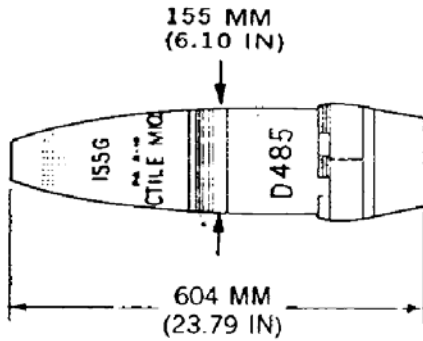

Projectile, 155 mm, Practice. M101

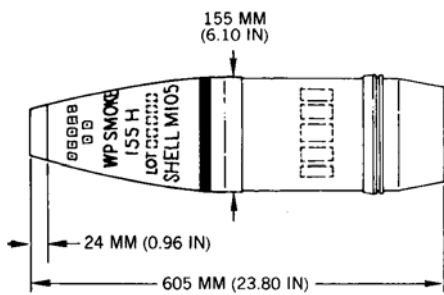

Projectile, 155 mm, Smoke. M105

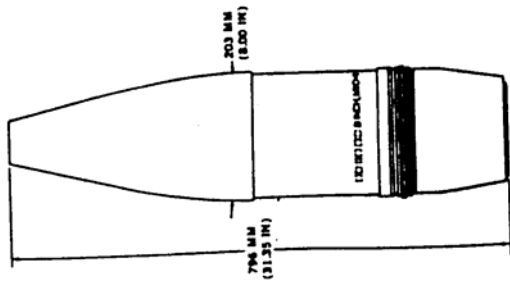

Projectile, 8-inch, HE. M106

ORDNANCE IMAGES - INDIRECT FIRE

E.3 ORDNANCE IMAGES – BOMBING AND GUNNERY

Table E-3. Bombing and Gunnery Ordnance Examples

Category	Type	Purpose	Model Series	Diameter (mm)	ORDATA II ID
Bomb	3-lb	Practice	Mk3, Mk4, Mk5, AN-Mk23, Mk43	56	3032
	4-lb	Fragmentation	M83 (Butterfly)	79	188
		Incendiary, TH3	AN-M50 Series, AN-M54, M126	43	3737
	6-lb	Incendiary	AN-M69, AN-M69X	80	3031
	10-lb	Incendiary	M74; M74A1	71	3751
	20-lb	Fragmentation	AN-M41; AN-M41A1	92	3055
		Practice	M48	92	3792
	25-lb	Practice	BDU-33 Series	102	287
	100-lb	General Purpose	Mk1	201	3079
		General Purpose	AN-M30; AN-M30A1 (Old Style)	208	3057
		Practice	M75	203	3794
		Practice	AN-M38A2	206	3725
		Incendiary	AN-M47	203	3056
	250-lb	General Purpose	AN-M57; AN-M57A1 (Old Style)	277	3065
500-lb	General Purpose	Mk3; Mk12	356	3092	
Bomblet	1-lb	Fragmentation, Cluster	BLU-26/B; BLU-36/B; BLU-59/B;	64	1031
		Practice, Cluster	BDU-26	64	1031
Projectile	20 mm	AP-T	M95	20	2864
	1.1-inch	Anti-Aircraft	Mk1	28	2974
Rocket	2.25-inch SCAR	Practice	Mk1	64	3332
	5.0-inch HVAR			127	5381
	2.75-inch FFAR	Motor	MK1, 2, 3, 4; SR105-AJ-1; LSFFAR, Mk40	70	282

SCAR - Sub-Caliber Aircraft Rocket

HVAR - High-Velocity Aircraft Rocket

FFAR - Folding-Fin Aircraft Rocket

Ordnance Images - Bombing and Gunnery

BOMBS

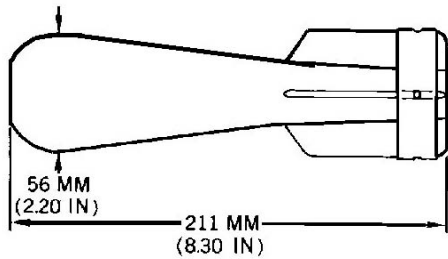

Bomb, 3-lb, Practice, MK 3, MK 4, MK 5, AN-MK 23, MK 43

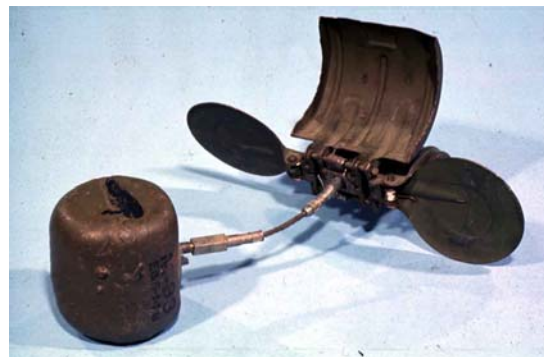
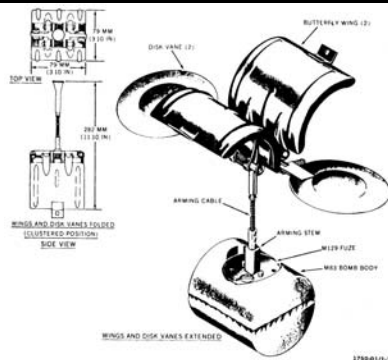

Bomb, 4-lb, Fragmentation, M83 (Butterfly)

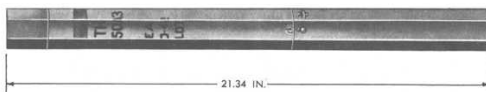

Bomb, 4-lb, Incendiary, TH3, AN-M50 SERIES, AN-M54, M126

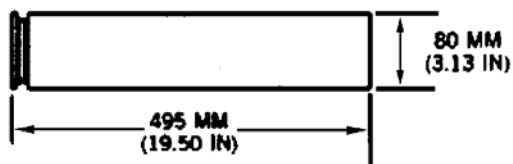

Bomb, 6-lb, Incendiary, Cluster, AN-M69, AN-M69X

Ordnance Images - Bombing and Gunnery

BOMBS

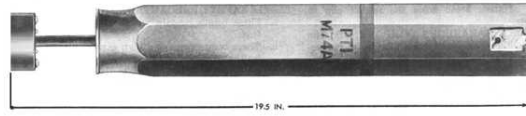

Bomb, 10-lb, Incendiary, Cluster, M74; M74A1

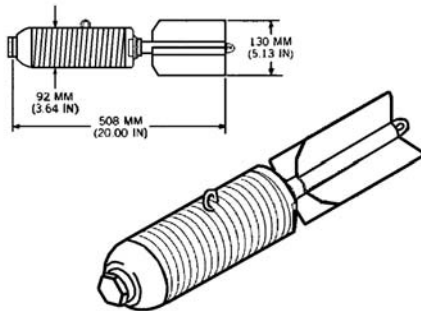

Bomb, 20-lb, Fragmentation, AN-M41; AN-M41A1

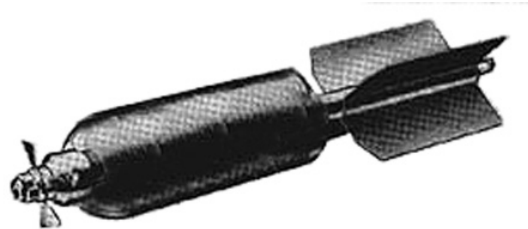

Bomb, 20-lb, Practice, M48

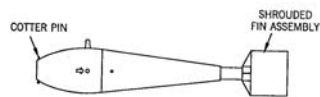
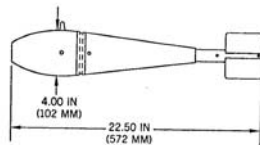

BDU-33/B



Bomb, 25-lb, Practice, BDU-33 SERIES

Ordnance Images - Bombing and Gunnery

BOMBS

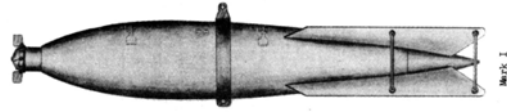
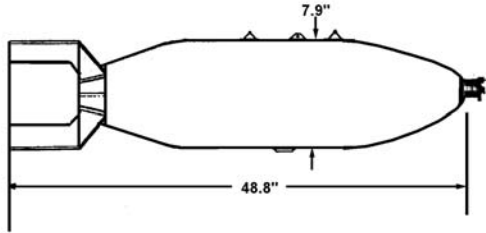

Bomb, 100-lb, General Purpose, MK 1

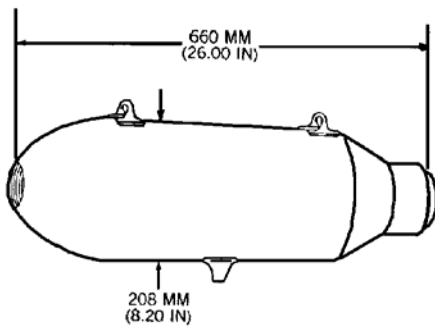

Bomb, 100-lb, General Purpose, AN-M30; AN-M30A1 (Old Style)

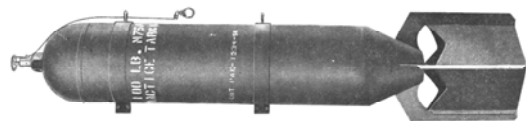

Bomb, 100-lb, Practice, M75



Bomb, 100-lb, Practice, AN-M38A2

Ordnance Images - Bombing and Gunnery

BOMBS

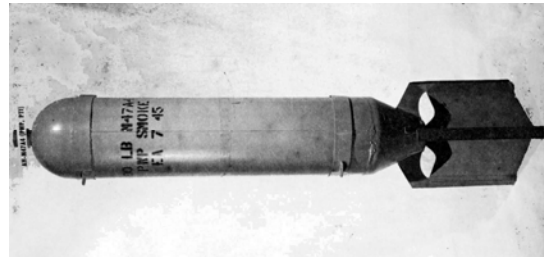
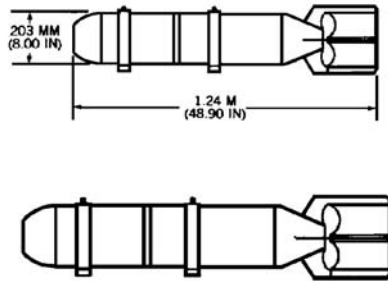

Bomb, 100-lb, Incendiary, AN-M47

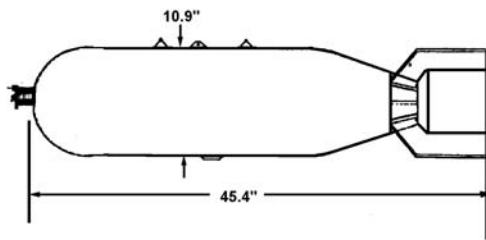

Bomb, 250-lb, General Purpose, AN-M57; AN-M57A1 (Old Style)

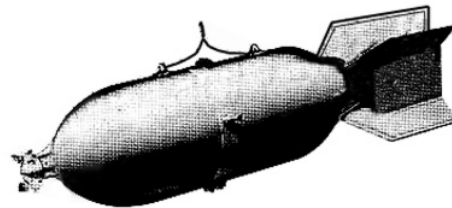
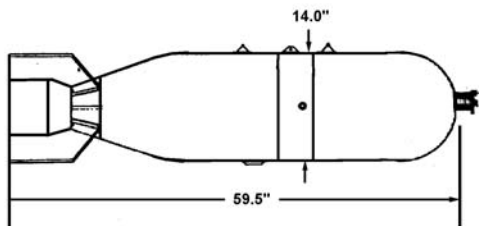

Bomb, 500-lb, General Purpose, Mk 3; Mk 12

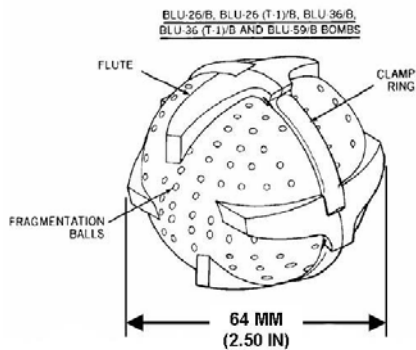

Bomblet, 1-lb, Fragmentation, BLU-26/B; BLU-36/B; BLU-59/B; BLU-36/B

Ordnance Images - Bombing and Gunnery

PROJECTILES

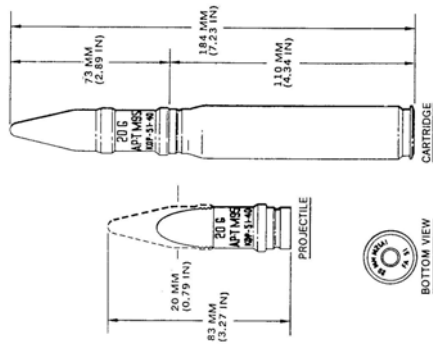

Projectile, 20 mm, AP-T, M95

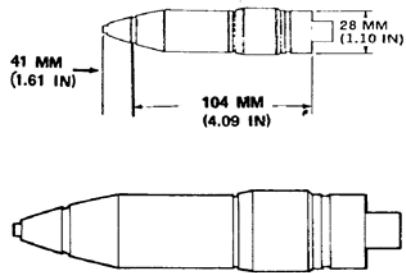

Projectile, 1.1-inch, Anti-Aircraft, Mk1

Ordnance Images - Bombing and Gunnery

ROCKETS

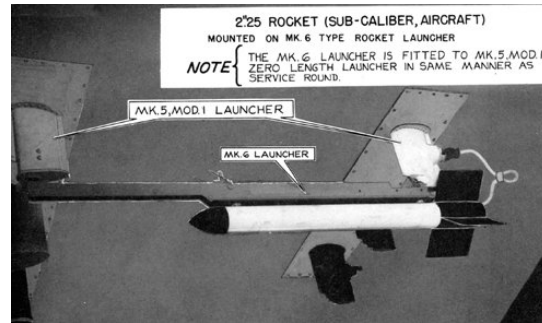
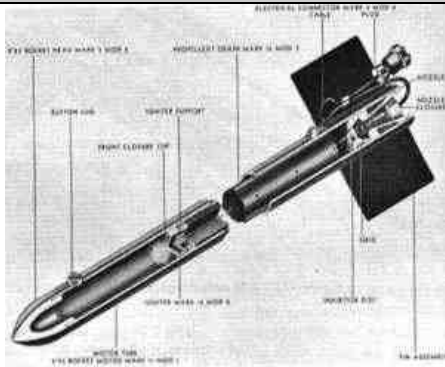

Rocket, 2.25-inch SCAR, Practice, Mk1

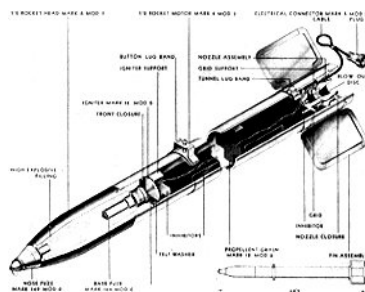

Rocket, 5.0-inch HVAR, ,

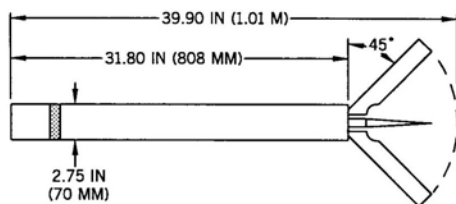

Rocket, 2.75-inch FFAR, Motor, MK1, 2, 3, & 4; SR105-AJ-1; LSFFAR, MK 40