

UNCLASSIFIED/ SANS CLASSIFICATION

**ENGINEERING DEVELOPMENT ANALYSIS OF A SEGMENTED PROJECTILE
DISCARDING SABOT**

FINAL REPORT

PREPARED FOR

DEFENCE R&D CANADA – VALCARTIER
R&D POUR LA DÉFENSE CANADA - VALCARTIER
QUEBEC, QC G3J 1X5
CANADA

Contract No.: XX

Guy Bergeron, Scientific authority
Tel: 418-844-4000 ext. 4443

By

É. Bélanger
P.Gosselin



NUMERICA TECHNOLOGIES INC.
3420 rue Lacoste
Québec, QC G2E 4P8 Canada

September 2005

UNCLASSIFIED

Report Documentation Page

Form Approved
OMB No. 0704-0188

Public reporting burden for the collection of information is estimated to average 1 hour per response, including the time for reviewing instructions, searching existing data sources, gathering and maintaining the data needed, and completing and reviewing the collection of information. Send comments regarding this burden estimate or any other aspect of this collection of information, including suggestions for reducing this burden, to Washington Headquarters Services, Directorate for Information Operations and Reports, 1215 Jefferson Davis Highway, Suite 1204, Arlington VA 22202-4302. Respondents should be aware that notwithstanding any other provision of law, no person shall be subject to a penalty for failing to comply with a collection of information if it does not display a currently valid OMB control number.

1. REPORT DATE SEP 2005		2. REPORT TYPE		3. DATES COVERED 00-00-2005 to 00-00-2005	
4. TITLE AND SUBTITLE Engineering Development Analysis of a Segmented Projectile Discarding Sabot				5a. CONTRACT NUMBER	
				5b. GRANT NUMBER	
				5c. PROGRAM ELEMENT NUMBER	
6. AUTHOR(S)				5d. PROJECT NUMBER	
				5e. TASK NUMBER	
				5f. WORK UNIT NUMBER	
7. PERFORMING ORGANIZATION NAME(S) AND ADDRESS(ES) Numerica Technologies Inc, 3420 rue Lacoste, Quebec, QC G2E 4P8 Canada,				8. PERFORMING ORGANIZATION REPORT NUMBER	
9. SPONSORING/MONITORING AGENCY NAME(S) AND ADDRESS(ES)				10. SPONSOR/MONITOR'S ACRONYM(S)	
				11. SPONSOR/MONITOR'S REPORT NUMBER(S)	
12. DISTRIBUTION/AVAILABILITY STATEMENT Approved for public release; distribution unlimited					
13. SUPPLEMENTARY NOTES					
14. ABSTRACT					
15. SUBJECT TERMS					
16. SECURITY CLASSIFICATION OF:			17. LIMITATION OF ABSTRACT	18. NUMBER OF PAGES	19a. NAME OF RESPONSIBLE PERSON
a. REPORT unclassified	b. ABSTRACT unclassified	c. THIS PAGE unclassified			

TABLE OF CONTENTS

1.0	INTRODUCTION.....	1
2.0	BACKGROUND AND CONSIDERATIONS.....	2
2.1	DISCARDING SABOT PHILOSOPHY	2
2.2	MATERIAL PROPERTIES	3
2.3	<i>NUMERICAL SIMULATION INFORMATION</i>	3
2.4	GENERAL SABOT LAYOUT	4
3.0	PRELIMINARY ANALYSIS	6
3.1	ANALYSIS OF PREVIOUS HYPERVELOCITY SABOT LAUNCH	6
3.2	ANALYTIC CALCULATION RESULTS	6
3.2.1	<i>DEFLECTION CALCULATIONS</i>	7
3.2.2	<i>STRESS CALCULATIONS</i>	7
3.2.3	<i>ANALYTIC RESULTS</i>	8
3.3	STATIC NUMERICAL SIMULATION RESULTS.....	9
4.0	PRELIMINARY DISCARDING CONCEPT ANALYSIS.....	13
4.1	<i>PRELIMINARY DISCARDING CONCEPT 1</i>	13
4.2	<i>PRELIMINARY DISCARDING CONCEPT 2</i>	14
4.3	<i>PRELIMINARY DISCARDING CONCEPT 3</i>	15
4.4	<i>PRELIMINARY DISCARDING CONCEPT 4</i>	16
4.5	<i>PRELIMINARY DISCARDING CONCEPT 5</i>	17
5.0	DISCARDING MODEL ANALYSIS FOR EXPERIMENTATION.....	19
5.1	FIRST LAUNCH SABOT CONCEPT ANALYSIS RESULTS.....	19
5.1.1	<i>PRESENTATION OF CONCEPT</i>	19
5.1.2	<i>STRESS RESULTS FOR COMPONENTS UNDER PRESSURE</i>	20
5.1.3	<i>ANALYSIS RESULTS FOR PETALS COMPONENTS</i>	22
6.0	CONCEPT EVALUATION WITH MORE SEGMENTS.....	27
6.1	ASSUMPTIONS TO INCREASE THE NUMBER OF SEGMENTS.....	27
6.2	PRELIMINARY CONCEPT WITH MORE SEGMENTS.....	27
7.0	CONCLUSION	31
8.0	APPENDIX.....	32

LIST OF FIGURES

Figure 1 – Example of discarding sabot	2
Figure 2 – General sabot layout.....	4
Figure 3 – Stress of petal only under the drag effect.....	9
Figure 4 – Deflection of petal only under the drag effect.....	10
Figure 5 – Stress of petal for a complete external shell under the drag effect.....	11
Figure 6 – Deflection of petal for a complete external shell under the drag effect	11
Figure 7 – Layout of preliminary discarding concept 1.....	13
Figure 8 – Layout of preliminary discarding concept 2.....	14
Figure 9 – Layout of preliminary discarding concept 3.....	15
Figure 10 – Layout of preliminary discarding concept 4.....	16
Figure 11 – Front view of the preliminary discarding concept 4.....	16
Figure 12 – Layout of preliminary discarding concept 5.....	17
Figure 13 – Layout of the first discarding launch concept (Changer image)	19
Figure 14 – Pusher plate stress in xy-axis for the discarding launch concept 1	20
Figure 15 – External shell stress in xy-axis for the discarding launch concept 1	21
Figure 16 – Pusher plate stress in y-axis for the discarding launch concept 1	21
Figure 17 – External shell stress in y-axis for the discarding launch concept 1	22
Figure 18 – Outside view of petal stress in x-axis for the discarding launch concept 1.....	23
Figure 19 – Inside view of petal stress in x-axis for the discarding launch concept 1	23
Figure 20 – Deflection of petal only for the discarding launch concept 1.....	24
Figure 21 – External shell stress in x-axis for the discarding launch concept 1	25
Figure 22 – Zoom on the external shell stress in x-axis for the discarding launch concept 1	25
Figure 23 – Deflection of the external shell for the discarding launch concept 1	26
Figure 24 – Assembly picture with 5 segments in the sabot.....	28
Figure 25 – Assembly picture with 8 segments in a full length sabot.....	29
Figure 26 – Assembly picture with 8 segments in a reduced length sabot.....	29
Figure 27 – Assembly picture with 10 segments in a full length sabot.....	30
Figure 28 – Assembly picture with 10 segments in a reduced length sabot.....	30

LIST OF TABLES

Table 1 – Material properties 3
Table 2 – Summary of variation for previous launch concept flight 6
Table 3 – Deflection of petals for different sabot characteristic 8
Table 5 – Characteristics of preliminary discarding concept 1 13
Table 6 – Characteristics of preliminary discarding concept 2 14
Table 7 – Characteristics of preliminary discarding concept 3 15
Table 8 – Characteristics of preliminary discarding concept 4 17
Table 9 – Characteristics of preliminary discarding concept 5 18
Table 10 – Characterisation of concepts with a different number of segments 27

1.0 INTRODUCTION

Developments and studies in hypervelocity conditions near Mach 6.7 show that a segmented projectile is more efficient in terms of penetration than an equivalent monolithic projectile. These projectiles are inserted in a sabot component for the launch. A sabot allows a projectile of a smaller calibre to be fired within a larger-bore accelerator. The sabot fills the bore of the gun during the firing stage. Usually, the sabot is a lightweight carrier. This means, the sabot's effect on the core mass must be minimal during the impact with the target. Even if the mass of the sabot is at a minimum; it represents a parasitic mass for the total launch assembly weight. To remove the sabot quickly during flight, it is possible to cut some petals on the sabot wall and put some angle on the front of the petals to help them rotate away from the projectile.

This report will put some attention on the opening of petals for the discarding sabot. The opening of petals will allow reducing the speed of the sabot and permit designing adequately the sabot trap. The opening of the petals will be considered for a few kind of design. This report will also evaluate the discarding sabot resistance and its capability to survive the loading conditions inside the light gas gun caused by the acceleration during the launch. Finally, this report will show the main results of the development for the sabot/projectile assembly in regards of increasing the weight of tungsten projectile. Some analytical calculations will be done to give some orientation before numerical simulations are done.

2.0 BACKGROUND AND CONSIDERATIONS

2.1 DISCARDING SABOT PHILOSOPHY

A basic discarding sabot configuration consists of a hollowed cylinder as shown in figure 1. To help the understanding, only half of the sabot is shown. This later is closed at one end and saw cut longitudinally. The cut divides the sabot in two or four sections called petals. The letter C identifies the petals. The polycarbonate seal prevents the leakage of gas in front of the sabot during acceleration. The letter A identifies the seal position. The darker arrow shows the movement direction of the sabot during the launch. The cavity identified by the letter B shows the room occupied by the projectile.

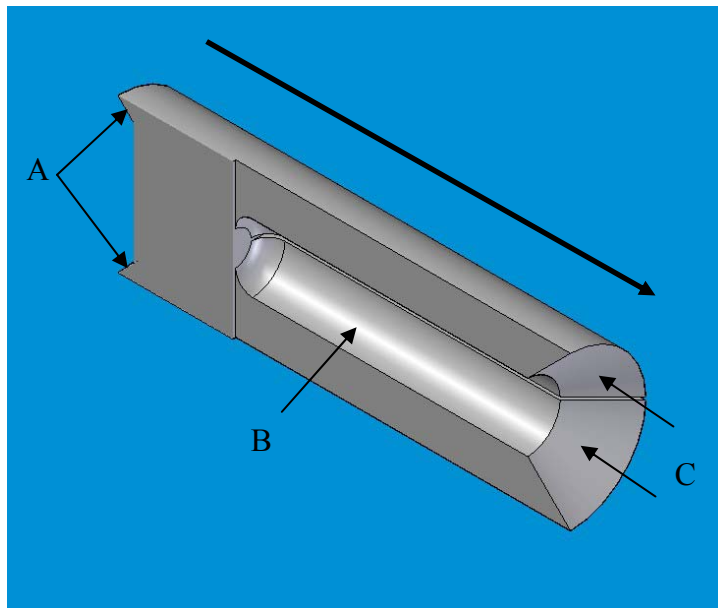

Figure 1 – Example of discarding sabot

After the sabot emerges from the gun barrel and gas pressure stops to be applied on it, the aerodynamic forces of lift and drag acting on the petals open and deviate it from the line of launch. At a precise position, the sabot petals impact against a piece of armour named the sabot trap. The sabot trap has a hole that coincides with the launch line to permit the projectile to reach the target while the sabot is stopped due to the deviation of its petals.

2.2 MATERIAL PROPERTIES

Table 1 shows the material properties for all the materials used in the launch package of the discarding sabot: tungsten alloy 490S, polycarbonate Lexan, carbon fiber and polyetherimide Ultem 1000. All the properties of this table were necessary to achieve a design with the engineering calculation or simulation analysis with a software. More details about the properties are available in appendix C.

Table 1 – Material properties

Material	Tungsten	Polycarbonate	Carbon fiber resin properties**	Carbon fiber fiber properties**	Ultem *
Density (g/cm ³)	17.15	1.20	1.19	1.80	1.28
Shear Strength (MPa)	N.A.	63.4	N.A.	N.A.	103.4
Tensile Strength (MPa)	1 472	72.4	179	4830	113.8
Compressive Strength (MPa)	N.A.	79.3	193	N.A.	151.7
Young Modulus (MPa)	275 000	2 413	1103	234 000	3 447
Poisson's Ratio	0.334	0.4	N.A.	N.A.	0.36

* The polyetherimide Ultem listed in this text is the material Ultem grade 1000. From now, to simplify the text, only the term Ultem will be used to represent the Ultem 1000.

** The fiber and the resin compose the carbon fiber product. The resin specification is the RP 4005 resin/RP 1500 Hardener while the fiber type is the 34-700.

2.3 NUMERICAL SIMULATION INFORMATION

All the models for the components analysis in the canon were prepared in the 2D modeling section of ANSYS®, a Finite Element Analysis (FEA) software. These numerical simulations were solved by ANSYS® also. This FEA software permits static analysis. Due to the axisymmetric nature of the problem, a 2D model was analysed to greatly reduce the amount of elements and solving resources.

All the models for the petals analysis outside the canon were prepared in the 3D modeling software named Solid Edge® specialized in modeling and drafting mechanical components in 3D. These parts were solved in a static condition by the FEA software ANSYS®. Due to the shape of the petal and the nature of the analysis, a simulation of a 3D model was necessary to obtain an appropriate answer.

2.4 GENERAL SABOT LAYOUT

This section gives preliminary information about the general discarding sabot layout and the general properties of every component. The discarding sabot layout comes mainly from the final concept of the previous sabot development project. For reference, this project was named engineering development analysis of a segmented projectile sabot. The basic concept of the discarding sabot was similar to the final concept at the exception that a reinforced sleeve was added and a front cover was removed.

Figure 2 shows the general discarding sabot layout for all components involved in this kind of concept. The dark yellow and the brown colours represent respectively the sabot and the pusher plate. The sabot is supposed to be in polycarbonate while the pusher plate is in Ultem. These two components are not supposed to reach the target. The black, the grey and the bronze colours represent respectively the reinforced sleeve, the segments and the spacers. These last components are supposed to hit the target together. The reinforced sleeve is supposed to be in carbon fiber, the segments are in Tungsten and the spacers are in Ultem.

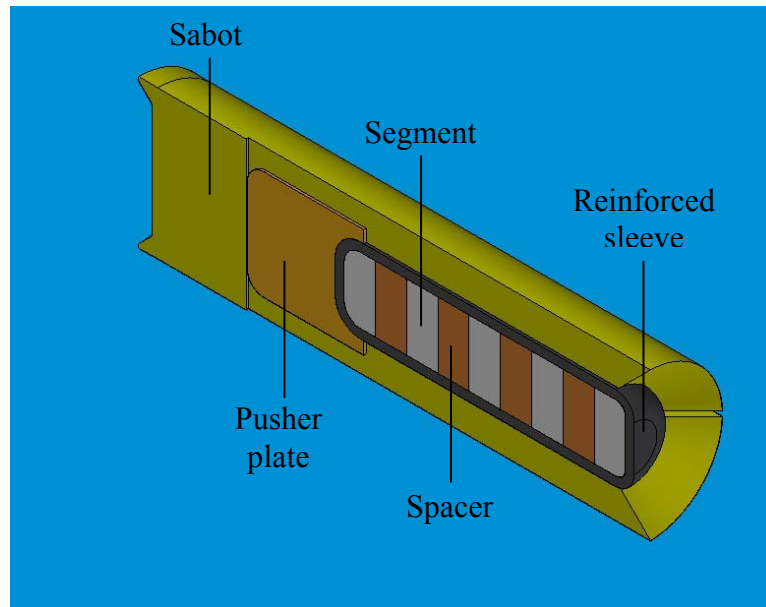

Figure 2 – General sabot layout

UNCLASSIFIED

The overall projectile dimensions are the same than as the previous project. Some changes were necessary on the pusher plate to permit the introduction of the reinforced sleeve. In fact, the radius in contact with the reinforced sleeve will be increased and the sidewall of the pusher plate will be thinned. Other change, the sabot will be longer with an angle at the front end to help the opening of the sabot during flight.

3.0 PRELIMINARY ANALYSIS

3.1 ANALYSIS OF PREVIOUS HYPERVELOCITY SABOT LAUNCH

This section gives all the detailed results in regard of maximum deviation and flight angle for the launch concepts of the previous development project. The measurements were taken directly on the x-ray. Table 2 gives the maximum value for the deviation and the flight angle of the launch test between L18 and L25. The results for L24 are unfortunately not available.

Table 2 – Summary of variation for previous launch concept flight

Launch Number	Maximum deviation (mm)	Maximum flight angle (Degree)
L 18	3.68	0.73
L 19	2.95	1.19
L 20	2.95	0.73
L 21	5.16	0.45
L 22	6.63	1.27
L 23	1.47	1.09
L 25	3.68	0.36

The launch L22 represents the launch concept with the most important value of deviation and angle during flight in comparison with the line of fire. The maximum deviation for this launch was 6.63 mm and the angle of flight was 1.27 degree.

These values have been considered in the evaluation of the minimum diameter for the opening of the sabot trap. In regard with this point, the calculation in appendix A shows that the sabot trap diameter must have a minimum of 42 mm to permit a projectile of 28 mm of diameter to pass the sabot trap in the worst case of deviation equivalent to the launch 22 without a safety factor. The calculation DISCARDING-EC-G-01 is available in appendix A for the calculation detail of the sabot trap opening.

3.2 ANALYTIC CALCULATION RESULTS

This section gives a value of petal deflection without exceeding the maximum stress of the material for every type of design. In fact, the number, the length, the material and the shape of the petal influence this calculation. To simplify the analysis, the

petal is taken as a cantilever beam where the component of drag tries to open the petal and permit the separation of the sabot and the projectile.

3.2.1 DEFLECTION CALCULATIONS

Equation 3.1 gives all the parameters that changes the deflection value.

$$D = \frac{\left(\frac{F_{dr}}{n}\right) \times L^3}{(3 \times E \times I)} \quad (3.1)$$

Where D is the deflection of the petal
 F_{dr} is the force of drag for the component in the radius axis
 n is the number of petals on the sabot
 L is the length of the petal
 E is the Young modulus of the petal material
 I is the moment of inertia of the petal section

In the case of Preliminary Discarding Concept 1 with four polycarbonate petals of 22.1 mm in length, the deflection is equivalent to 0.69 mm if equation 3.1 is used. This deflection value is good if the drag force in the radius axis is equal to 3173 N and the moment of inertia for the petal is equal to 15 752 mm⁴. This result is showed in the last column of the fourth line in table 3. This detailed calculation of deflection is also available in appendix A at the calculation number DISCARDING-EC-B-04.

3.2.2 STRESS CALCULATIONS

Equation 3.2 gives all the parameters that change the stress value.

$$S = \left(\frac{F_{dx}}{A_p \times n}\right) + \left(\frac{F_{dy} \times L \times c}{I \times n}\right) \quad (3.2)$$

Where F_{dx} is the drag force for the component in the length axis
 F_{dy} is the drag force for the component in the radius axis
 n is the number of petals on the sabot
 A_p is the area of the petal
 L is the length of the petal
 c is the neutral fibber of the petal
 I is the moment of inertia of the petal section

In the case of Preliminary Discarding Concept 1 with four polycarbonate petals of 22.1 mm long, the maximum stress is equivalent to 72.3 MPa if equation 3.2 is used. This stress is good if the drag force in the radius axis is equal to 3173 N and the moment of inertia for the petal is equal to 15 752 mm⁴. This result is showed in the second column of the fourth line in table 3. This detailed calculation of deflection is also available in appendix A at the calculation number DISCARDING-EC-B-04.

3.2.3 ANALYTIC RESULTS

This section gives the analytic results for every design in term of maximum deflection. Table 3 gives the petal's deflection in term of petal's stress and length. The deflections in table 3 are at their maximum when the stress reaches a value of 72.3 MPa for the polycarbonate and 113.3 MPa for the Ultem material. Over these values, the chance of petal failure increases rapidly.

Table 3 – Deflection of petals for different sabot characteristics

PDC 1 – Polycarbonate external shell + Ultem pusher plate			
Polycarbonate external shell			
# of petal	Maximum stress(MPa)	Maximum Length(mm)	Deflection(mm)
No petal	26	-	0.129
2 petals	72.3	99	6.44
3 petal	72.3	32.4	1.02
4 petals	72.3	22.1	0.69
Ultem pusher plate			
# of petal	Maximum stress(MPa)	Maximum Length(mm)	Deflection(mm)
No petal	18	-	0.071
2 petals	35.5	94.5	3.1
3 petal	45.7	94.5	0.8
4 petals	55.2	94.5	0.5
PDC 2 – Ultem sabot assembly			
# of petal	Maximum stress(MPa)	Maximum Length(mm)	Deflection(mm)
No petal	24	-	0.092
2 petals	69.3	94.5	4.3
3 petal	113.3	61.2	4
4 petals	113.3	44.3	2.4
PDC 3, 4 & 5 – Polycarbonate sabot assembly			
# of petal	Maximum stress(MPa)	Maximum Length(mm)	Deflection(mm)
No petal	-	-	-
2 petals	72.4	103.9	8.1
3 petal	72.4	40	1.6
4 petals	72.4	29.7	1.05

The PDC 1 for example, refers to the Preliminary Discarding Concept 1. Every concept number named in this table is detailed in section 4.0.

The deflection results showed in table 3 are all developed in detail in appendix A. In this appendix, the calculation numbers DISCARDING-EC-B-01 to DISCARDING-EC-B-04 and DISCARDING-EC-C-01 to DISCARDING-EC-C-04 are in link with the PDC 1. The calculation numbers DISCARDING-EC-D-01 to DISCARDING-EC-D-04 are in link with the PDC 2. Finally, the calculation numbers DISCARDING-EC-B-05 to DISCARDING-EC-B-08 are in link with the PDC 3, 4 and 5.

3.3 *STATIC NUMERICAL SIMULATION RESULTS*

Even though the first concepts of sabot were assessed by analytical calculations, they were formally evaluated by static numerical simulation. In fact, the petal only and the complete external shell with all petals are compared in term of numerical simulation result.

3.3.1 Analysis on petal only

This section shows the results of numerical analysis for a petal that represents a hollow cylinder divided by four. The petal length is equal to 30 mm long. This value doesn't include the length of angle at the end of the petal.

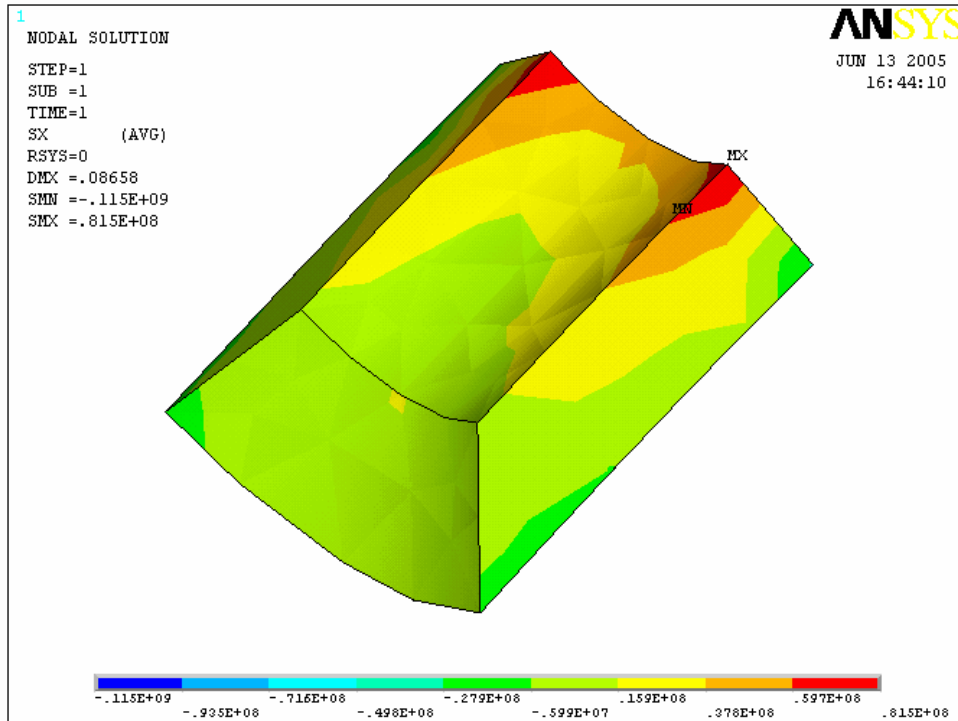

Figure 3 – Stress of petal only under the drag effect

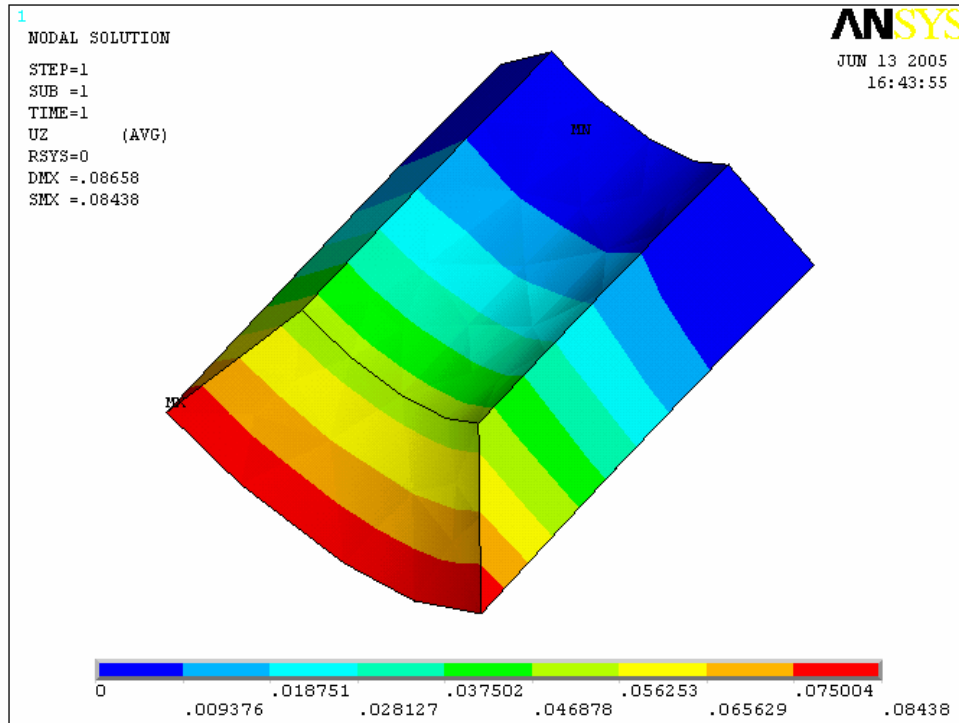

Figure 4 – Deflection of petal only under the drag effect

Figure 3 shows the petal simulation result for the stress in the y-axis. The maximum stress occurred in compression at the outside surface of the petal. The maximum stress was around 115 MPa at this place. The admissible value of compression for the polycarbonate is 79.3 MPa. This last value represents the stress of compression when a deformation equivalent to 10 % occurs. This means that the outside surface of the petal will have a deformation higher than 10 % in compression. Also, a maximum tensile stress occurred at the inside surface of the petal. This maximum value was around 81.5 MPa. This value was over the admissible value of 72.4 MPa for the tensile strength of polycarbonate. This means a failure in compression/tension would occur on the petal at the region in contact with the external shell for a concept with polycarbonate material.

Figure 4 shows the petal simulation result for the displacement in the z-axis. This axis is equivalent to the radius axis. The maximum displacement was equivalent to 0.0843 mm at the maximum petal length.

3.3.2 Complete external shell analysis

This section shows the results of numerical analysis for a complete external shell that includes four petals. The petal length is equal to 30 mm long. As for the previous section, this value doesn't include the length of angle at the end of the petal.

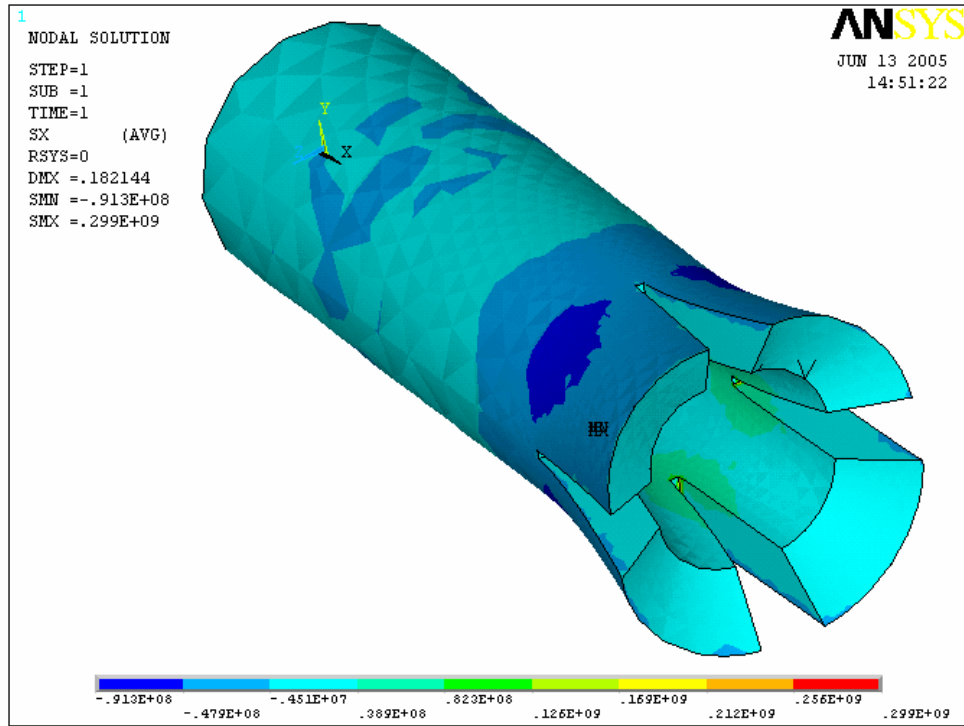

Figure 5 – Stress of petal for a complete external shell under the drag effect

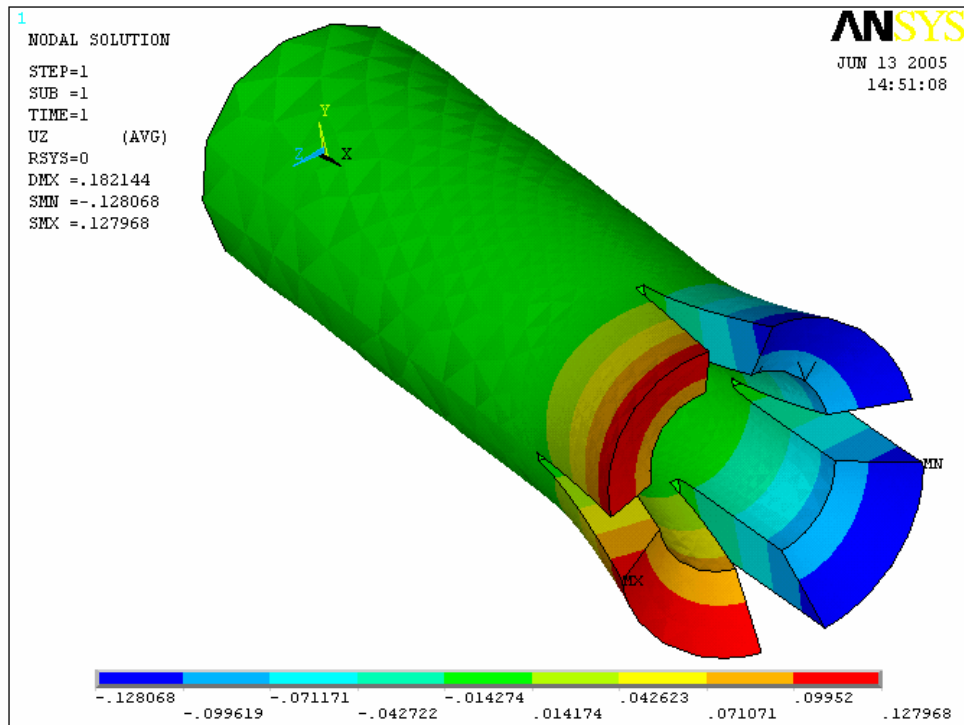

Figure 6 – Deflection of petal for a complete external shell under the drag effect

Figure 5 shows the entire external shell simulation result for the stress in the y-axis. The maximum stress occurred in tension at the region where the external shell body and the petals were in contact. The maximum stress was around 299 MPa at this place. The admissible value of tension for the polycarbonate is 72.4 MPa. The maximum stress value is higher for this simulation than for the simulation of figure 3 because the stress concentration factor due to the shape is more important for the external shell simulation. Also, a maximum compression stress occurred at the outside surface of the petal. This maximum value was around 91.3 MPa. This value was over the admissible value of 79.9 MPa for the compression strength of polycarbonate. This means a failure in compression/tension would occur in the region between the petal and the external shell for a concept with polycarbonate material.

Figure 6 shows the entire external shell simulation result for the displacement in the z-axis. The maximum displacement was equivalent to 0.128 mm at the maximum petal length. This displacement is 52 % more important than the displacement of the petal identified in figure 4. This difference could be explained by the fact that the entire external shell takes some deformations not included in the displacement results of figure 4.

4.0 PRELIMINARY DISCARDING CONCEPT ANALYSIS

This section gives a list of preliminary discarding concepts with a summary explanation, advantage and the disadvantage of every proposed concept.

4.1 PRELIMINARY DISCARDING CONCEPT 1

This preliminary discarding concept is exactly the same as presented in the section of general sabot layout. The materials and the dimensions are also the same. The brown, blue, green and orange colour represent respectively the polycarbonete, the Ultem, the carbon fiber and the tungsten material. Figure 7 shows the components layout for this concept.

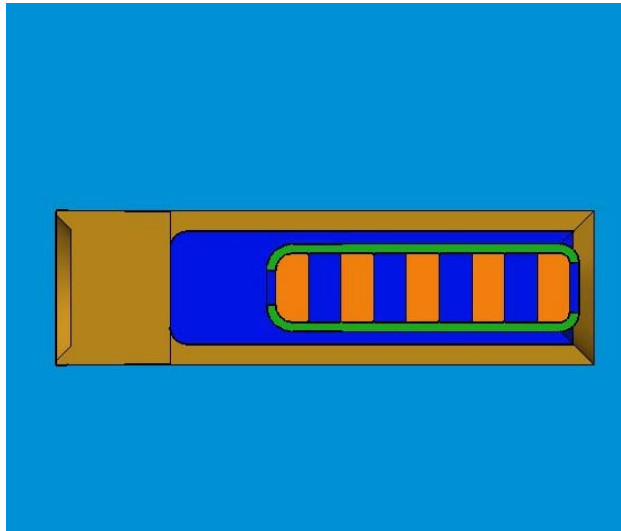

Figure 7 – Layout of preliminary discarding concept 1

Table 5 – Characteristics of preliminary discarding concept 1

#	Concept characteristics	Advantage	Disadvantage
1	The dimensions of components are similar to the previous project of sabot development.	X	
2	The liberation of the projectile included the opening of sabot and pusher plate successively.		X
3	The cavity to machine in the sleeve is very long.		X

Characteristic 1 in table 5 is an advantage because the components have already been tested and increase our confidence in the assembly strength resistance during the launch. Characteristic 2 is a disadvantage because the pusher plate must wait the opening of the sabot, but it needs to open very rapidly otherwise it will reach the target with the projectile. The timing of opening for the sabot and the sleeve is very important since the time of flight is very short. Characteristic 3 is a disadvantage because a long cavity such as this one needs special tools and special precautions for the machining.

4.2 PRELIMINARY DISCARDING CONCEPT 2

This preliminary discarding concept is entirely fabricated in Ultem. In fact, the Ultem has replaced the polycarbonate and only a small blade of polycarbonate ensures the contact between the sabot and the bore of the canon. The distribution of colour follows the same rule as presented in the previous preliminary discarding concept. Figure 8 shows the components layout for this concept.

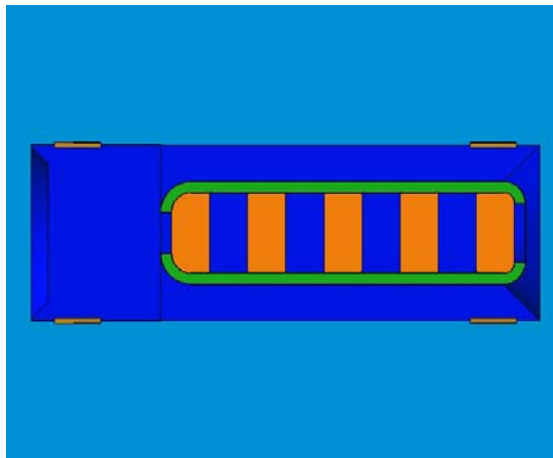

Figure 8 – Layout of preliminary discarding concept 2

Table 6 – Characteristics of preliminary discarding concept 2

#	Concept characteristics	Advantage	Disadvantage
1	The length and the weight of the sabot assembly is reduced	X	
2	The opening of only one component liberates the projectile	X	
3	The cavity to machine in the sleeve is very long.		X
4	The concept of polycarbonate blade around a hypervelocity sabot has never been tried		X

Characteristic 1 in table 6 is an advantage because this permits to increase the ratio of tungsten on the total weight assembly. This is also interesting because it allows

increasing the number of tungsten segments in the future. The weight and the length are reduced because the entire region in polycarbonate near the pusher plate is eliminated. Characteristic 2 is an advantage because it simplifies the process of opening in comparison with concept 1. Characteristic 3 has the same explanation as concept 1. Characteristic 4 is a disadvantage because this kind of concept brings some new development ideas and reduces the confidence in the product.

4.3 PRELIMINARY DISCARDING CONCEPT 3

This preliminary discarding concept is entirely fabricated in Polycarbonate except for the pusher plate components. The polycarbonate is injected around the pusher plate to shape the sabot. The distribution of colour follows the same rule as presented in the preliminary discarding concept 1. Figure 9 shows the components layout for this concept.

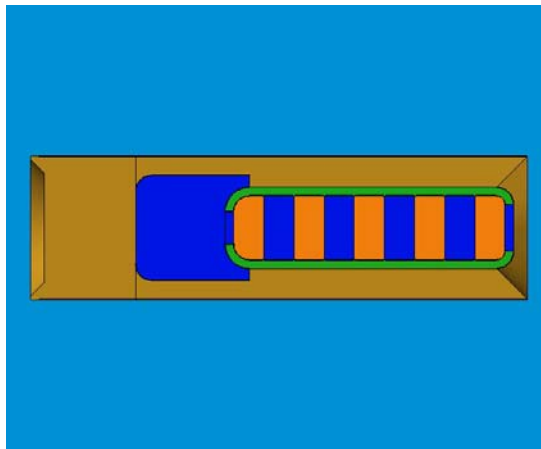

Figure 9 – Layout of preliminary discarding concept 3

Table 7 – Characteristics of preliminary discarding concept 3

#	Concept characteristics	Advantage	Disadvantage
1	The pusher plate component is trapped in the sabot	X	
2	The opening of only one component liberates the projectile	X	
3	The section of the petal is variable on his own length		X
4	The polycarbonate sabot must be injected to meet the specification		X

Characteristic 1 in table 7 is an advantage because if the pusher plate component is trapped in the sabot, it will not be an additional projectile following the tungsten projectile. Therefore, only the tungsten projectile will touch the target. Characteristic 2 has the same explanation as concept 2. Characteristic 3 is a

disadvantage because the change of section creates an additional stress concentration on the component. Characteristic 4 is a disadvantage because the RDDC facilities are not adequate to inject a polycarbonate sabot for this volume. Therefore, the fabrication will be sent outside RDDC, thus it will be more complicated to manage and to control.

4.4 PRELIMINARY DISCARDING CONCEPT 4

This preliminary discarding concept is the same than the previous concept as for one exception, the presence of the positioning plate to support the projectile during the flight. The positioning plates are bonded on the sabot after the machining. These positioning plates are represented by the yellow colour even they are in polycarbonate material. The distribution of colour for other components follows the same rule as presented in the preliminary discarding concept 1. Figure 10 shows the components layout for this concept. Figure 11 shows the link between positioning plates and the other components.

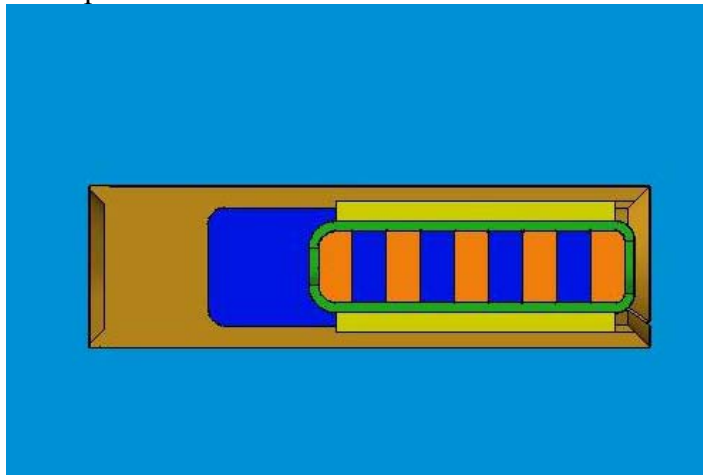

Figure 10 – Layout of preliminary discarding concept 4

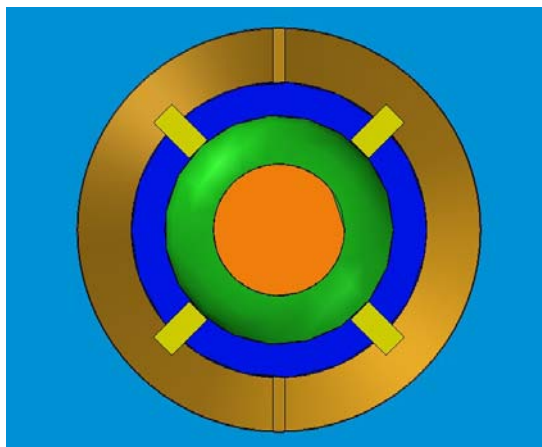

Figure 11 – Front view of the preliminary discarding concept 4

Table 8 – Characteristics of preliminary discarding concept 4

#	Concept characteristics	Advantage	Disadvantage
1	The pusher plate component is trapped in the sabot	X	
2	The opening of only one component liberates the projectile	X	
3	The additional components on the petals are bonded		X

Characteristics 1 and 2 have the same explanation as the previous concept. Characteristic 3 is a disadvantage because the bonded positioning plates must be very resistant; otherwise the sabot flight would create new fragments on the target in comparison with other preliminary discarding concepts.

4.5 PRELIMINARY DISCARDING CONCEPT 5

This preliminary discarding concept is entirely fabricated in Polycarbonate except for the pusher plate components. The polycarbonate is divided in two parts in the longitudinal axis. The polycarbonate parts are entirely separated during flight. The grey part at the rear of the sabot is the seal in a Neoprene rubber disc. The distribution of colour for other components follows the same rule as presented in the preliminary discarding concept 1. Figure 12 shows the components layout for this concept.

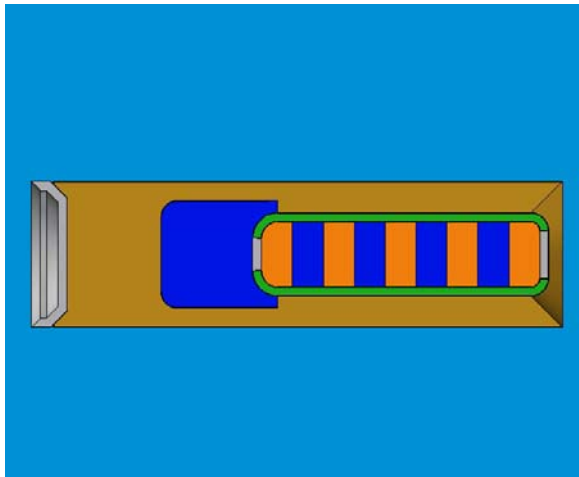

Figure 12 – Layout of preliminary discarding concept 5

Characteristic 1 in table 9 is an advantage, because this permits to focus on the appropriate component for the success of the discarding process. Characteristic 2 is a disadvantage because the pusher plate would influence the penetration of the target by the fact it would touch the target almost at the same time as the tungsten projectile. Finally, Characteristic 3 is a disadvantage because a sabot entirely cut on

the length brings some complex behaviour during flight. This concept is hard to simulate and to prevent before any representative tests.

Table 9 – Characteristics of preliminary discarding concept 5

#	Concept characteristics	Advantage	Disadvantage
1	The opening of only one component liberates the projectile	X	
2	When the sabot open, the pusher plate is not trapped in the sabot		X
3	The separation of the sabot during flight is complex		X

5.0 DISCARDING MODEL ANALYSIS FOR EXPERIMENTATION

5.1 FIRST LAUNCH SABOT CONCEPT ANALYSIS RESULTS

This section gives all the detailed results in regard with the first launch-discarding concept chosen for the discarding sabot experimentation in the gas gun. The following sections 4.1.2 and 4.1.3 will cover results in term of components analysis. Particularly, results for pressure component strength and petal strength under drag will be covered.

5.1.1 PRESENTATION OF CONCEPT

This first discarding launch concept is equivalent to the preliminary discarding concept 3, presented in section 4.3. The petal length of this concept is shorter than the petal length presented in the section of the preliminary concept. In fact, the petal length (represented by a black oval) is evaluated at 21 mm without considering the length of the angle at the end of the petal. The carbon fiber sleeve traps the projectile composed by 5 tungsten segments and by 4 Ultem spacers. The pusher plate is machined and a polycarbonate sabot is injected around the pusher plate. With this concept, the pusher plate is trapped inside the polycarbonate sabot.

Figure 13 shows the layout of the first discarding launch concept assembly. The clear yellow, dark red, black, clear grey and bronze colours represent respectively the discarding polycarbonate sabot, the Ultem pusher plate, the carbon fiber sleeve, the tungsten segment and the Ultem spacer. The projectile components are loaded by the front.

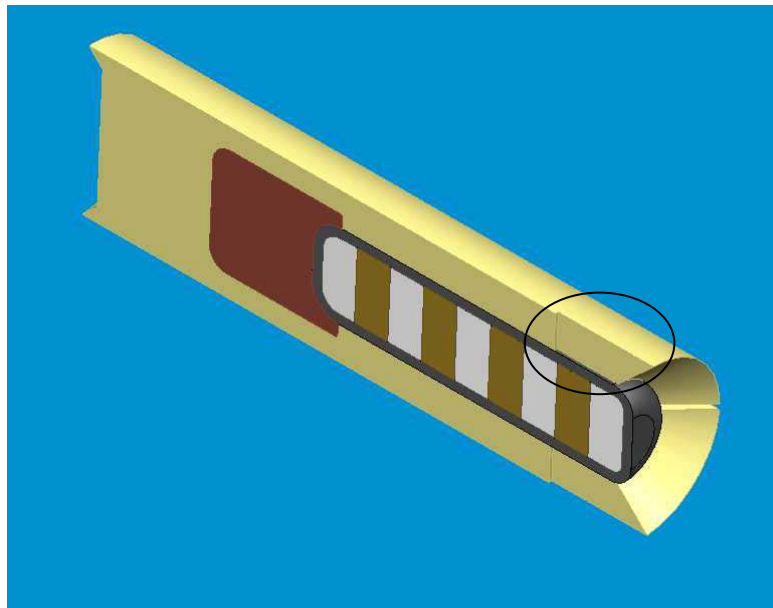

Figure 13 – Layout of the first discarding launch concept

5.1.2 STRESS RESULTS FOR COMPONENTS UNDER PRESSURE

This section gives the static analysis results on the sabot assembly components such as the pusher plate, the external shell and the internal sleeve around the projectile. This analysis is done to evaluate the component strength under pressure in the canon independent of petal analysis. This means, the number and the distance between the petals are not taken into consideration in this type of analysis. The results will be evaluated for the stress in xy and y-axis.

Figure 14 shows the pusher plate numerical simulation result for the stress in the xy-axis. This component is used in the discarding launch concept 1.

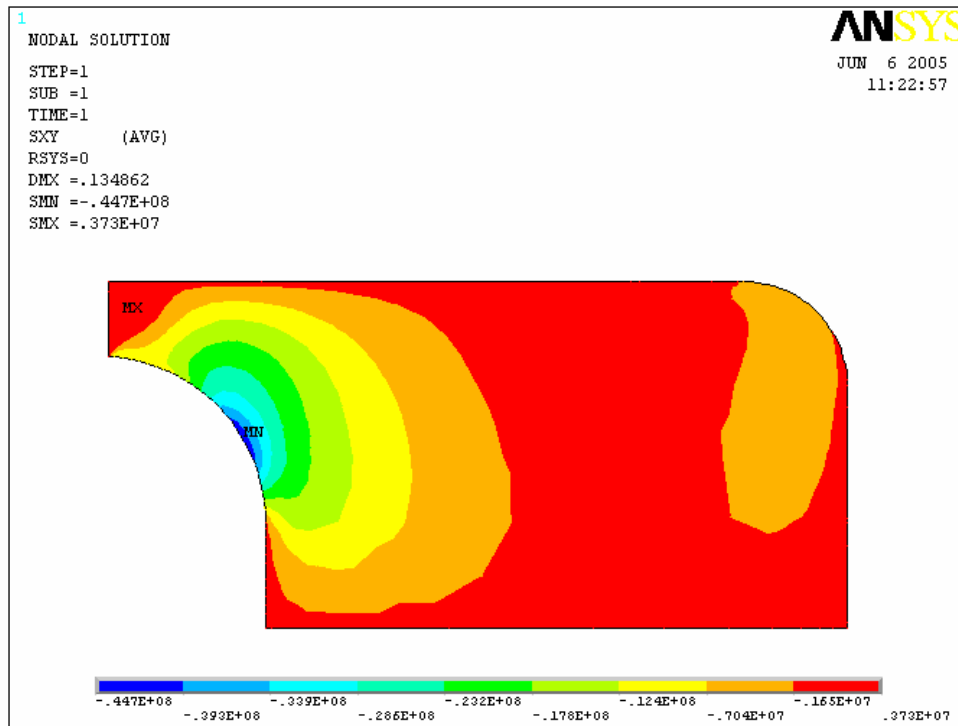

Figure 14 – Pusher plate stress in xy-axis for the discarding launch concept 1

In the previous figure, a stress concentration occurred at the radius in contact with the the projectile. The maximum shear stress was around 44.7 MPa at this place. The admissible value for the Ultem is 103.4 MPa. This means the pusher plate with these dimensions and this shape would resist in shear to the launch of the discarding launch concept 1.

Figure 15 shows the external shell numerical simulation result for the stress in the xy-axis. A stress concentration occurred at the radius in contact with the pusher plate. The maximum shear stress was around 17.8 MPa at this place. The admissible value for the polycarbonate is 72.4 MPa. This means the external shell with these dimensions and this shape would resist in shear to the launch of the discarding launch concept 1.

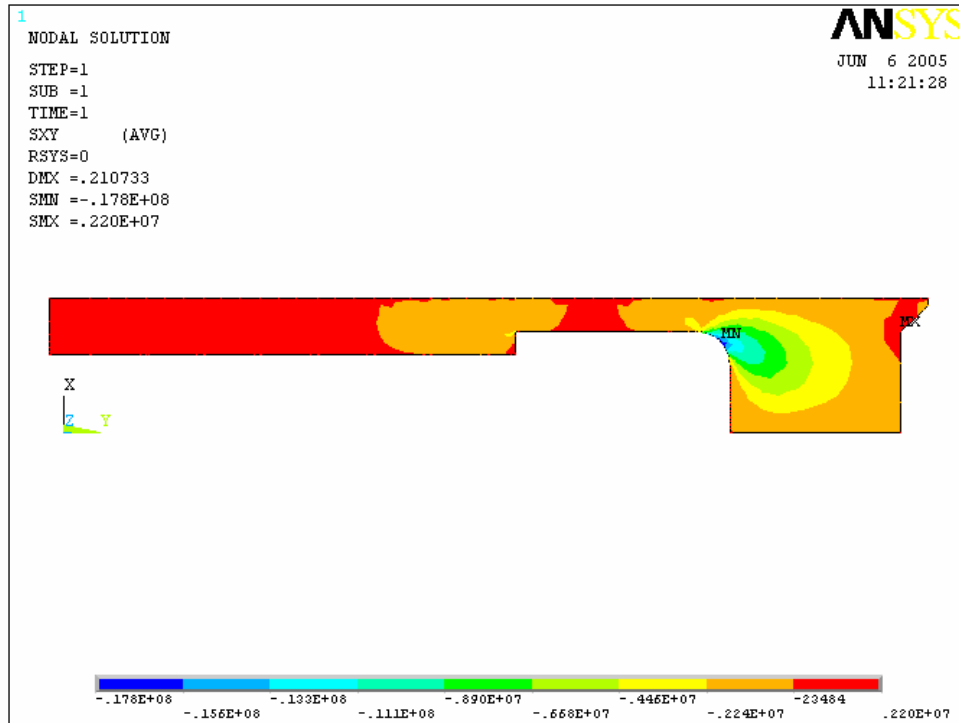

Figure 15 – External shell stress in xy-axis for the discarding launch concept 1

Figure 16 shows the pusher plate numerical simulation result for the stress in the y-axis. This component is used in the discarding launch concept 1.

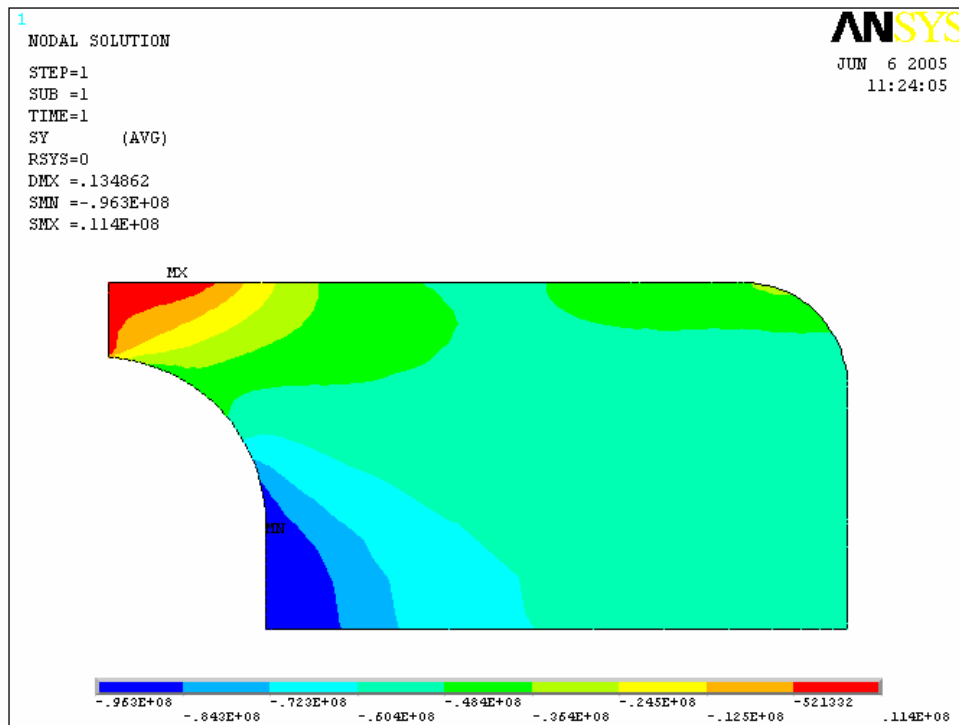

Figure 16 – Pusher plate stress in y-axis for the discarding launch concept 1

In the previous figure, a maximum compression stress occurred at the rear of the tungsten projectile. The maximum value was around 54.1 MPa. This value was under the admissible value of 151.7 MPa for the Ultem. This means the pusher plate with these dimensions and this shape would resist in compression to the launch of the discarding launch concept 1.

Figure 17 shows the external shell numerical simulation result for the stress in the y-axis. A maximum compression stress occurred rear the pusher plate. This maximum value was around 54.1 MPa. This value was under the admissible value of 79.9 MPa for the compressive strength of polycarbonate. Also, a maximum tensile stress occurred at the end of the radius in link with the sidewall part of the external shell. This maximum value was around 18.9 MPa. This value was under the admissible value of 72.4 MPa for the tensile strength of polycarbonate. This means the external shell would resist in tension and compression to the launch in the discarding launch concept 1.

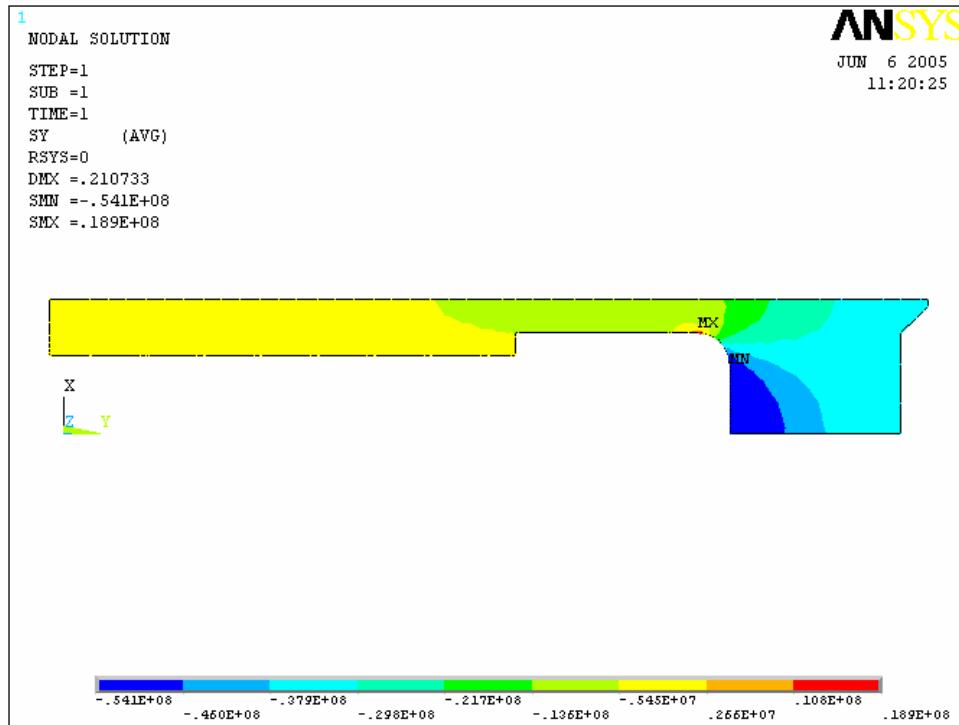

Figure 17 – External shell stress in y-axis for the discarding launch concept 1

5.1.3 ANALYSIS RESULTS FOR PETALS COMPONENTS

This section gives the static analysis results on the external shell petal components around the projectile. The simulations are conducted respectively on the petal only and also on the external shell. The results will be evaluated for the deformation in the z-axis and the stress in x-axis. Figures 18 and 19 show respectively the outside and inside view of the petal numerical simulation result, for the stress in the x-axis of the discarding launch concept 1. For these figures, the maximum compression value

of 74.0 MPa was under the admissible value of 79.9 MPa for the compressive strength of polycarbonate. In tensile, the maximum value of 62.2 MPa was under the admissible value of 72.4 MPa for the tensile strength of polycarbonate.

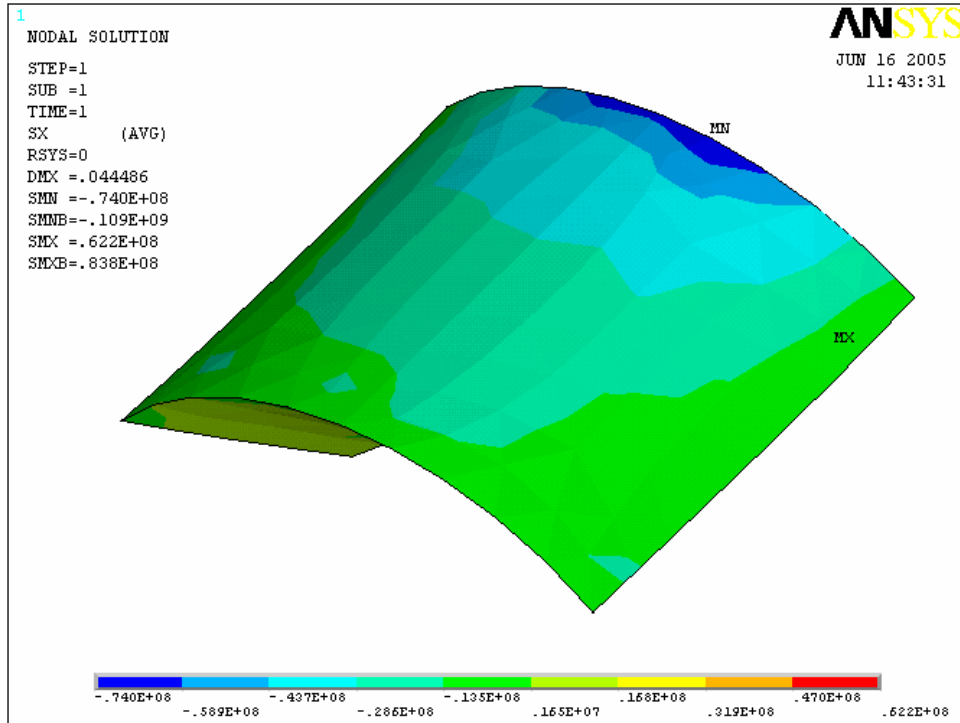

Figure 18 – Outside view of petal stress in x-axis for the discarding launch concept 1

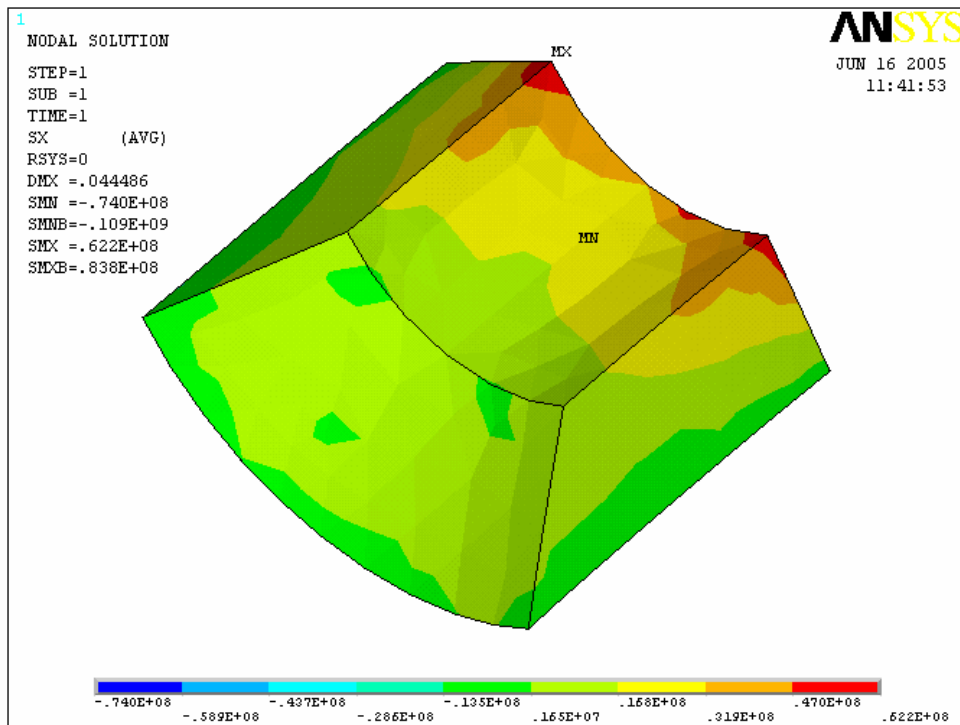

Figure 19 – Inside view of petal stress in x-axis for the discarding launch concept 1

Figure 20 shows the petal simulation result for the displacement in the z-axis of the discarding launch concept 1. The maximum displacement was equivalent to 0.0433 mm at the maximum petal length.

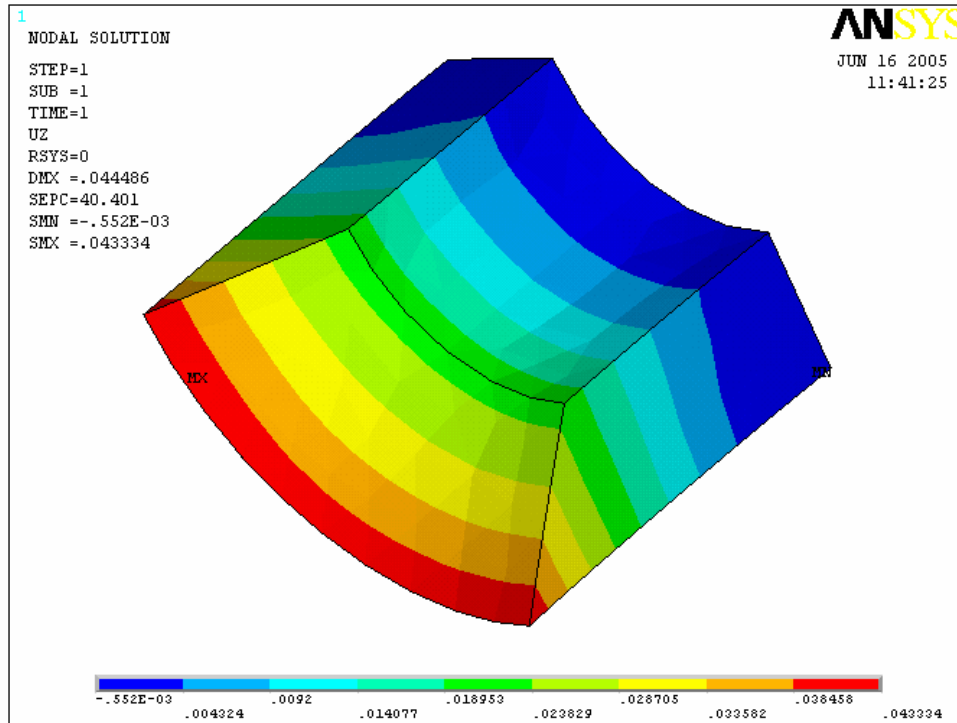

Figure 20 – Deflection of petal only for the discarding launch concept 1

Figures 21 and 22 show the external shell numerical simulation result, for the stress in the x-axis of the discarding launch concept 1. Figure 21 gives a global result of the external shell stress distribution. In the opposite, figure 22 gives more details about the external shell stress distribution around the petal. For these figures, the maximum compression value of 58.8 MPa was under the admissible value of 79.9 MPa for the compressive strength of polycarbonate. In tensile, the maximum value of 198.8 MPa was over the admissible value of 72.4 MPa for the tensile strength of polycarbonate. Figure 22 allows to see that the tensile stress on the petal doesn't exceed a stress value of 26.9 Mpa. The zoomed area of figure 22 also allows to identify that the maximum tensile is only on the edge between the end of the petal and the external shell body (See the black circle with the arrow). This section of the external shell has some chances to break in regards to the stress value. The failure on this small region of the external shell reduces the chance of success, but doesn't mean that the launch concept is not able to bring the projectile properly to the target. For this reason, the launch concept 1 would have to be evaluated by a dynamic simulation software.

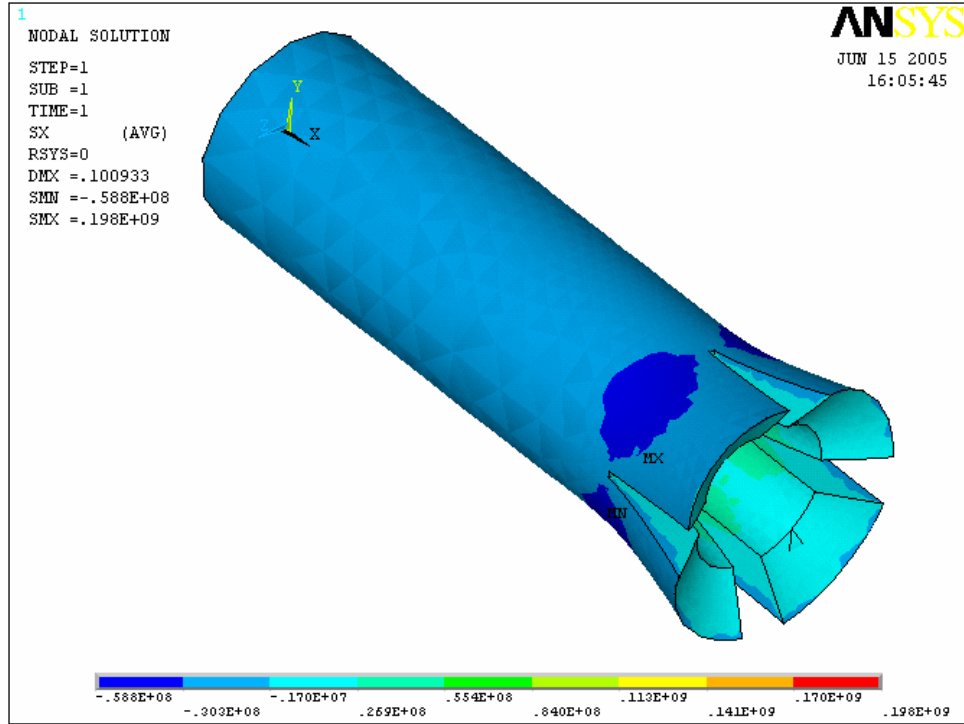

Figure 21 –External shell stress in x-axis for the discarding launch concept 1

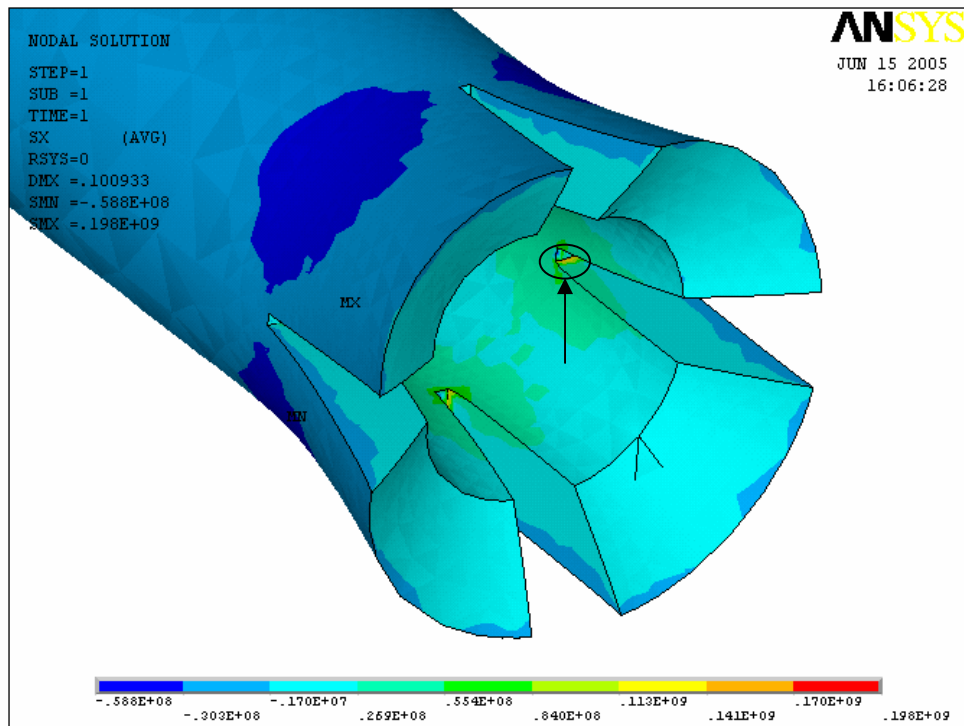

Figure 22 –Zoom on the external shell stress in x-axis for the discarding launch concept 1

Figure 23 shows the external shell simulation result for the displacement in the z-axis of the discarding launch concept 1. The maximum displacement was equivalent to 0.0708 mm at the maximum petal length.

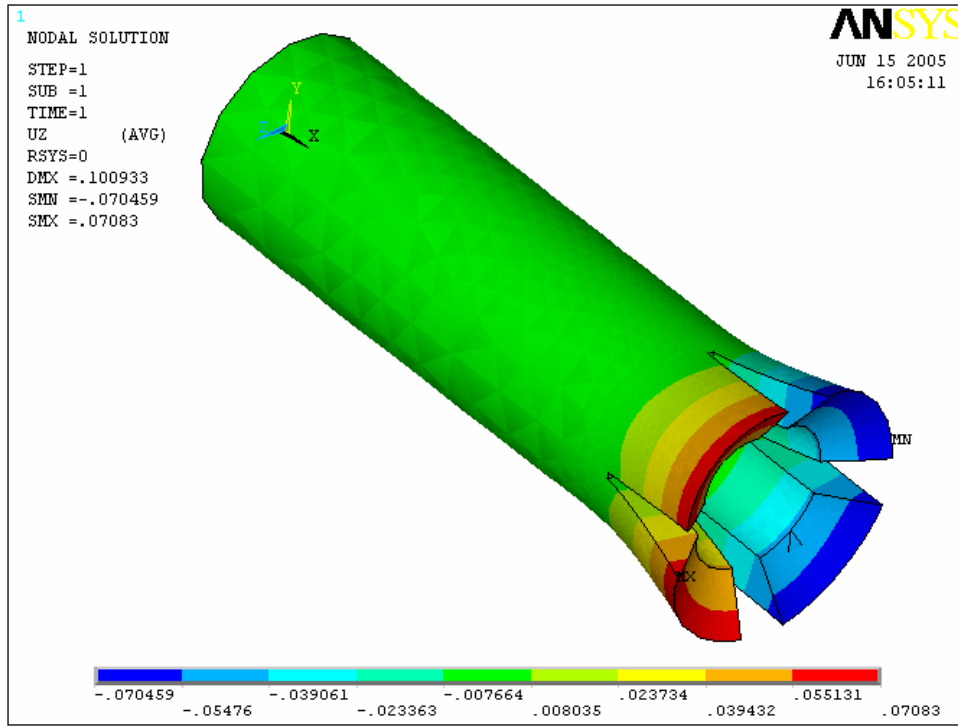

Figure 23 – Deflection of the external shell for the discarding launch concept 1

6.0 CONCEPT EVALUATION WITH MORE SEGMENTS

This section gives some new ideas of what the model will look like if the number of segments inside the actual model of sabot is increased, until predetermined weights of 1200 and 1500 grams are reached. This exercise permits to evaluate the maximum segments a concept similar to the actual one could contain during the launch.

6.1 ASSUMPTIONS TO INCREASE THE NUMBER OF SEGMENTS

The following assumptions were taken in consideration to propose the concept of the next section :

- The external shell diameter remains the same.
- The length of components at the rear of the projectile such as pusher plate and external shell are longer in proportion of weight increase. This means a projectile 50 % heavier will need a pusher plate and an external shell 50 % longer.
- The pusher plate and the external shell are fabricated in the same material.
- The shape components are the same as for previous concept of sabot assemblies.

6.2 PRELIMINARY CONCEPT WITH MORE SEGMENTS

This section shows the different weight and length of concepts that use different number of segments. In particular, concepts with 5, 8 and 10 segments are evaluated in terms of mass for the sabot, the tungsten projectile and the total assembly. The total length was also evaluated for these concepts. Table 10 gives all details about the concepts. The * symbol in table 10 means that this concept use a reduced length sabot assembly.

Table 10 – Characterisation of concepts with a different number of segmensts

Number of segment	Mass of sabot (g)	Mass of projectile (g)	Total mass (g)	Total length (mm)
5	322	398	720	176.9
8	507	645	1152	275
8*	436	645	1081	231
10	643	810	1453	346
10*	572	810	1382	302

The first line concept of table 10 is showed in figure 24. This concept is composed by 5 segments in a full length sabot. This concept is equivalent to previous one proposed in this report.

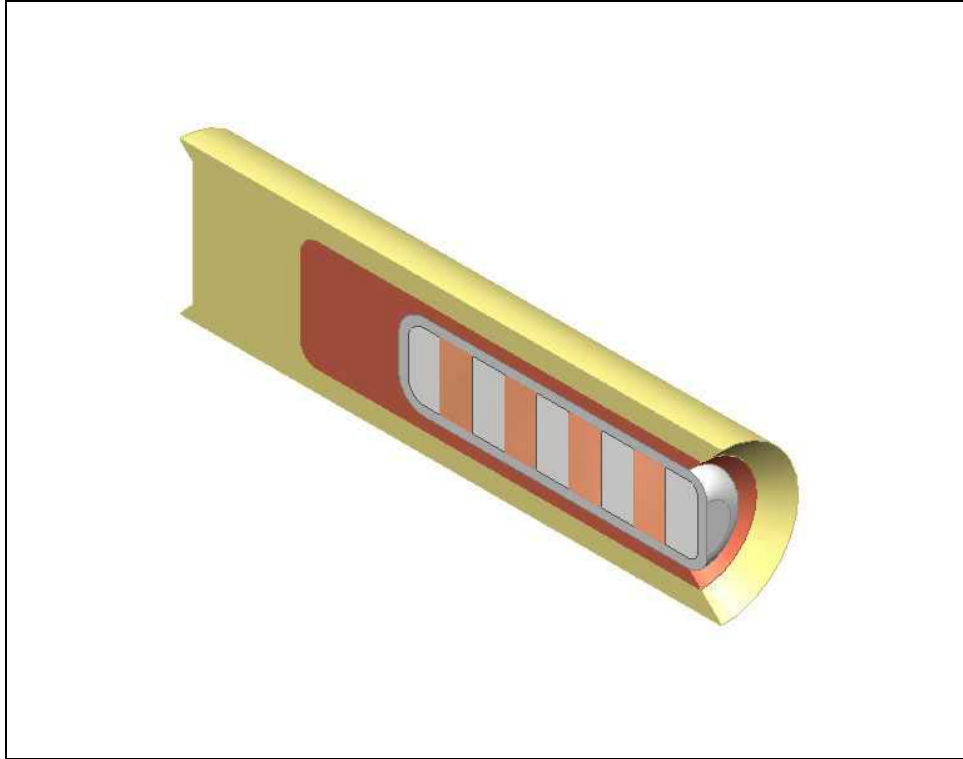

Figure 24 – Assembly picture with 5 segments in the sabot

The next four lines of table 10 are showed in the next figures of the report.

Particularly, the second line of table 10 is the concept with 8 segments in a full length sabot assembly. This concept is represented by figure 25 at the next page. The third line of the same table is the concept with 8 segments in a reduced length sabot assembly. This late is represented by figure 26.

Figures 27 and 28 show respectively the concept with 10 segments for a full length sabot and a reduced length sabot. These figures are available in the next two pages.

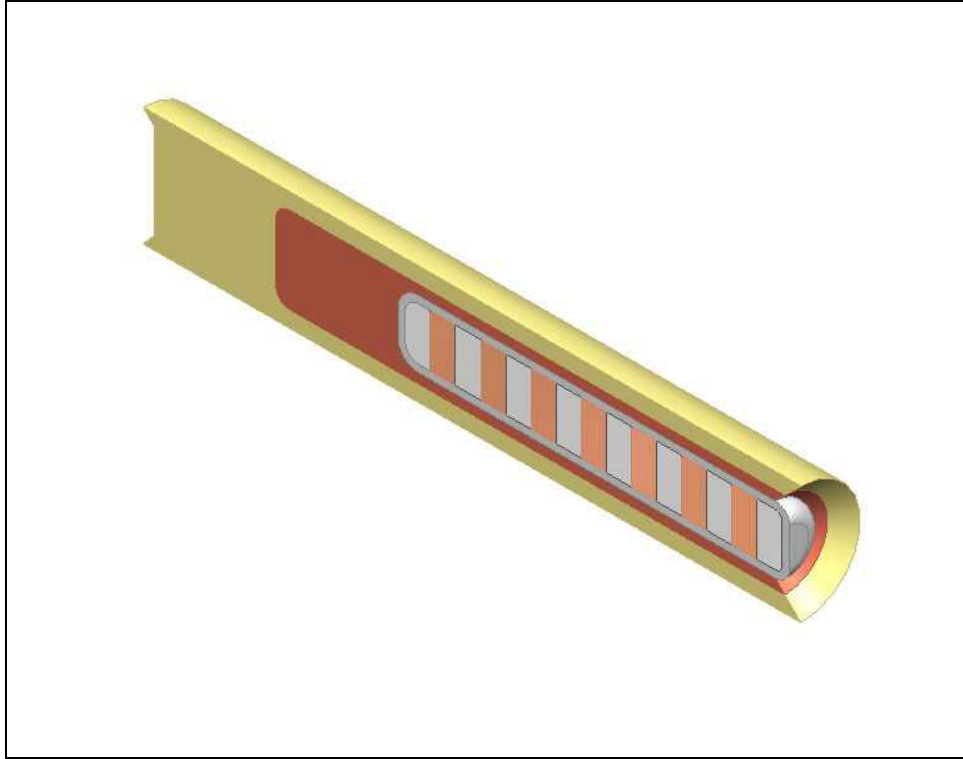

Figure 25 – Assembly picture with 8 segments in a full length sabot

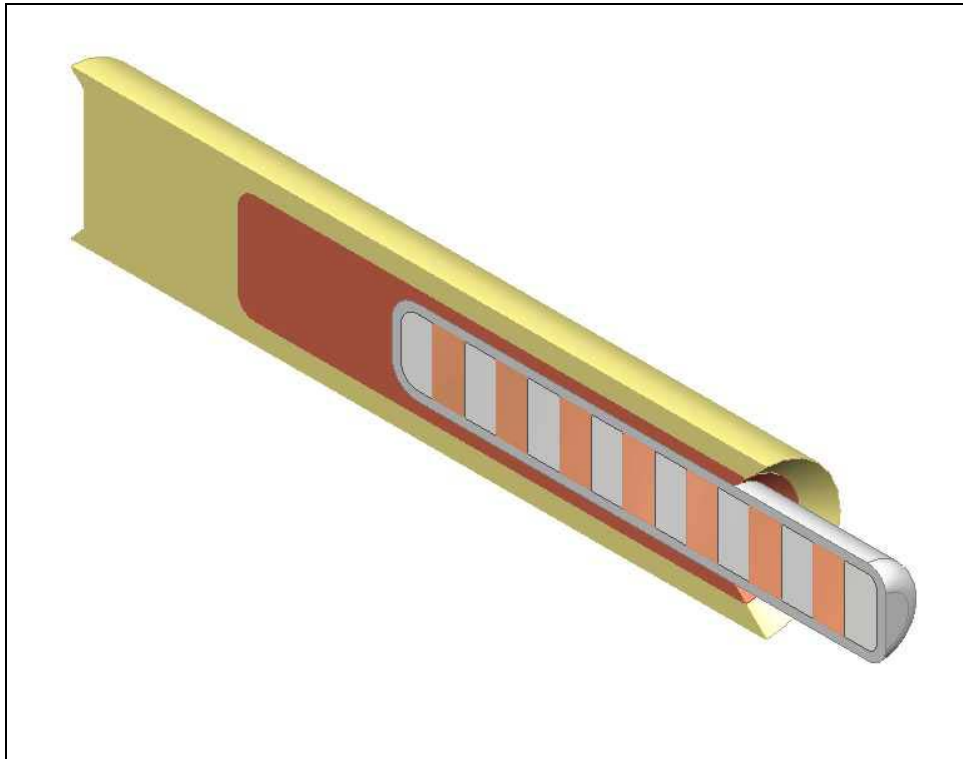

Figure 26 – Assembly picture with 8 segments in a reduced length sabot

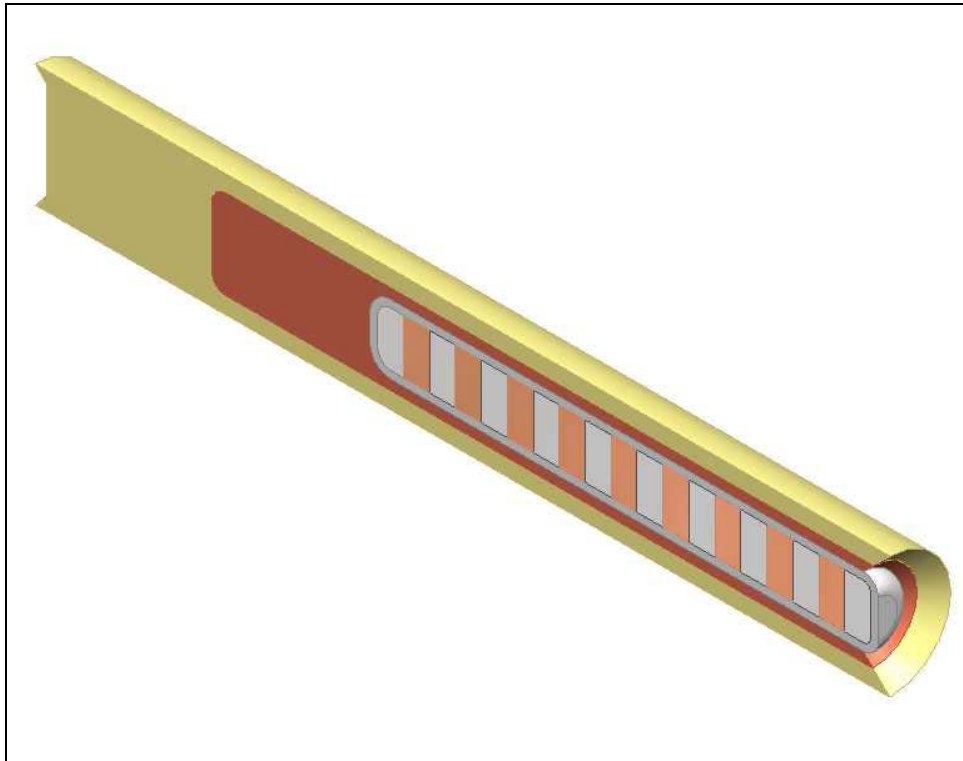

Figure 27 – Assembly picture with 10 segments in a full length sabot

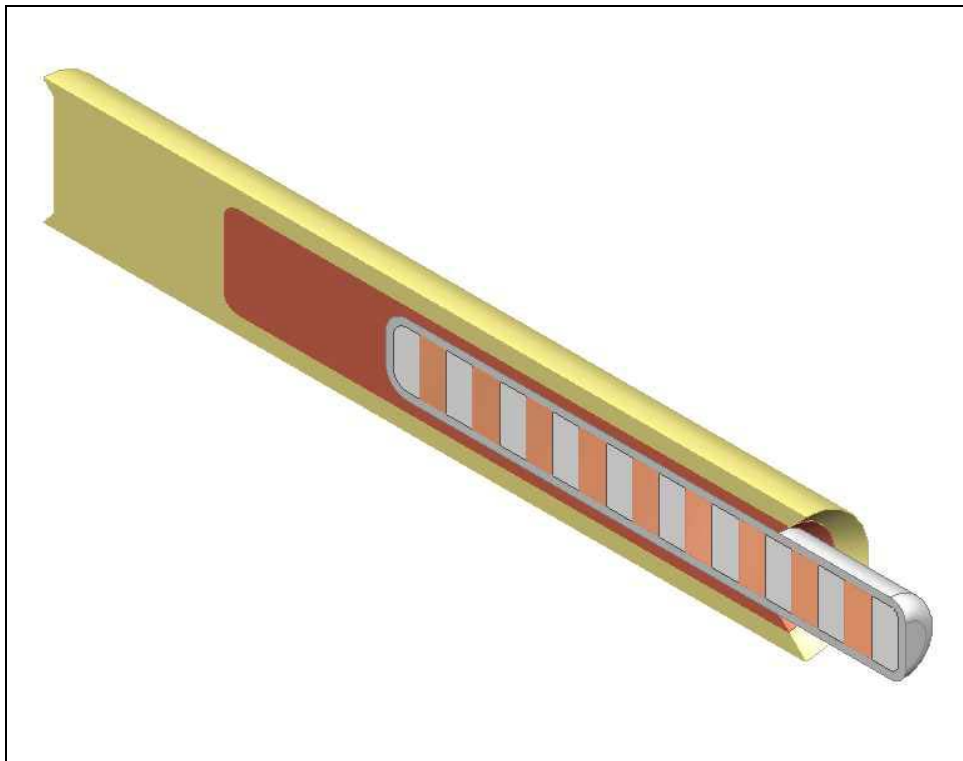

Figure 28 – Assembly picture with 10 segments in a reduced length sabot

7.0 CONCLUSION

This report puts some attention on the discarding sabot resistance and on its capability to open sufficiently during flight at the exit of the light gas gun. Also, this report covers the sabot assembly modification and the impact an increase of the number of segments could have on it..

The process of development had allowed to give a preliminary orientation for the discarding sabot assembly under drag during flight. The static analytical calculation and the static numerical simulations have been done to evaluate the petal strength under the drag effect. These analyses permitted to identify the length, the general shape and the number of petals. Particularly, the analyses allowed to show that a potential polycarbonate sabot solution, with four petals, could resist the drag and open if their length did not exceeded 30 mm.

This report conducts some preliminary solutions concerning weight and dimensions analysis of the sabot to evaluate the effect of increased number of segments inside the projectile. The results showed that solutions with 8 and 10 segments are realistic for a respective total weight of 1100 and 1400 grams.

The process of development had allowed giving preliminary orientation for the solution mainly in terms of petal characteristics and projectile segments number. Particularly, the length, the general shape and the number of petal have been identified with a good level of precision. Also, solutions with more segments have showed as interesting solution for a future firing test at DRDC light gas gun facility.

To improve considerably the performances of the design, it would be interesting to do additional analysis on the projectile. The following points define a list of possible future analysis to improve some part of the total discarding sabot assembly.

Simulation of petals on a dynamic software

This report covered the analysis of petal by static analysis tools only. The answer permitted to evaluate a preliminary solution. Some additional simulations by dynamic software will allow covering petal behaviour in flight at different steps of movement in the impact chamber.

Change the shape and the material of components

This report covered the preliminary design aspect of the petal. To improve the discarding sabot behaviour, it is possible to modify the shape and the material that would increase the petal strength and help to the opening of petal during flight. The evaluation of these design points is possible only with accurate analysis tools as mentioned in the previous point.

8.0 APPENDIX

A – COMPLETE ENGINEERING CALCULATIONS

B – LAUNCH CONCEPT DRAWINGS