

REPORT DOCUMENTATION PAGE

Form Approved
OMB No. 0704-0188

The public reporting burden for this collection of information is estimated to average 1 hour per response, including the time for reviewing instructions, searching existing data sources, gathering and maintaining the data needed, and completing and reviewing the collection of information. Send comments regarding this burden estimate or any other aspect of this collection of information, including suggestions for reducing the burden, to Department of Defense, Washington Headquarters Services, Directorate for Information Operations and Reports (0704-0188), 1215 Jefferson Davis Highway, Suite 1204, Arlington, VA 22202-4302. Respondents should be aware that notwithstanding any other provision of law, no person shall be subject to any penalty for failing to comply with a collection of information if it does not display a currently valid OMB control number.
PLEASE DO NOT RETURN YOUR FORM TO THE ABOVE ADDRESS.

1. REPORT DATE (DD-MM-YYYY) March 1980	2. REPORT TYPE Workshop proceedings	3. DATES COVERED (From - To)
--	---	-------------------------------------

4. TITLE AND SUBTITLE Proceedings of the MIT/ONR Workshop on Distributed Communication and Decision Problems Motivated by Naval C3 Systems (2nd): Volume 2	5a. CONTRACT NUMBER N00014-77-C-0532
	5b. GRANT NUMBER
	5c. PROGRAM ELEMENT NUMBER

6. AUTHOR(S) Michael Athans	5d. PROJECT NUMBER
	5e. TASK NUMBER
	5f. WORK UNIT NUMBER

7. PERFORMING ORGANIZATION NAME(S) AND ADDRESS(ES) Laboratory for Information and Decision Systems, Massachusetts Institute of Technology, Cambridge, MA 02139	8. PERFORMING ORGANIZATION REPORT NUMBER LIDS-R-967
--	---

9. SPONSORING/MONITORING AGENCY NAME(S) AND ADDRESS(ES) Office of Naval Research 875 North Randolph Street Arlington, VA 22203	10. SPONSOR/MONITOR'S ACRONYM(S) ONR
	11. SPONSOR/MONITOR'S REPORT NUMBER(S)

12. DISTRIBUTION/AVAILABILITY STATEMENT
Distribution Statement A; Approved for Public Release. U.S. Government or Federal Purpose Rights License.

13. SUPPLEMENTARY NOTES

14. ABSTRACT
Contents: Modeling the Influence of Information on the Progress of Combat; An Approach to the Evaluation of Technology for Utilization in Navy Command Control and Communications; A Methodology for Apprising the Combat Effectiveness of the Navy Command and Control System; Preliminary Thoughts on C3 System Modeling and Survivability; Some Thoughts on Navy Command and Control Technology Base Development; Design, Analysis and Simulation of a Distributed Surveillance Network The State Variables of a Command Control System.

15. SUBJECT TERMS

16. SECURITY CLASSIFICATION OF:			17. LIMITATION OF ABSTRACT UU	18. NUMBER OF PAGES 279	19a. NAME OF RESPONSIBLE PERSON
a. REPORT U	b. ABSTRACT U	c. THIS PAGE U			19b. TELEPHONE NUMBER (Include area code)

LIBRARY
RESEARCH REPORTS DIVISION
NAVAL POSTGRADUATE SCHOOL
MONTEREY, CALIFORNIA 93940

March, 1980

LIDS-R-967

Research Supported By:

Contract ONR/N00014-77-C-0532

OSP Number 85552

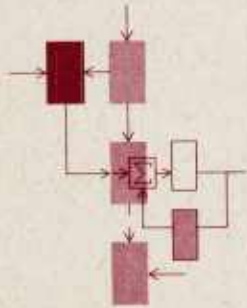

PROCEEDINGS OF THE SECOND MIT/ONR
WORKSHOP ON DISTRIBUTED COMMUNICATION
AND DECISION PROBLEMS MOTIVATED
BY NAVAL C³ SYSTEMS: VOLUME II

Vol. 2

Edited by
Professor Michael Athans

Laboratory for Information and Decision Systems
Formerly

Electronic Systems Laboratory

MASSACHUSETTS INSTITUTE OF TECHNOLOGY, CAMBRIDGE, MASSACHUSETTS 02139

//

December 1979

LIDS-R-967

Contract ONR/N00014-77-C-0532

PROCEEDINGS OF THE SECOND MIT/ONR
WORKSHOP ON DISTRIBUTED COMMUNICATION
AND DECISION PROBLEMS MOTIVATED BY
NAVAL C³ SYSTEMS: VOLUME II

Edited by

Professor Michael Athans

FORWARD

This series of four reports contain copies of the viewgraphs and related text material presented by most of the speakers at the second MIT/ONR Workshop on Distributed Communication and Decision Systems Motivated by Naval C³ Problems held at the Naval Postgraduate School, Monterey, CA from July 16 to July 27, 1979. The workshop was supported by the Office of Naval Research under contract ONR/N00014-77-C-0532 with M.I.T. The ONR contract monitor was Dr. Stuart Brodsky.

The purpose of this annual workshop is to encourage informal interactions between university, government, and industry researchers in basic problems in future military command and control problems. It is felt that the inherent complexity of C³ systems requires novel and imaginative thinking, theoretical advances, and the development of new basic methodologies in order to arrive at realistic, reliable, and cost effective designs for future C³ systems. Current and future needs, and work in progress (both theoretical and operations oriented) were presented. Extensive discussions took place following the presentations and during the afternoons.

The workshop attendees greatly benefited by presentations by operational officers. Gerald Thomas, Rear Admiral, USN and William Meyers, III, Rear Admiral, USN(ret.) gave thought provoking presentations on operational naval problems, the role of C³, and on war gaming. Unfortunately there is no text for their presentations. I am personally indebted to them for taking time from their busy schedules to attend the workshop and share their thoughts with the attendees.

In the same spirit, I am indebted to Lt. Col. E.H. Boyd and the many representatives of the U.S. Marine Corps for their fine presentation (including the movies!!!) in describing the elements of amphibious operations, and for the many stimulating discussions.

The interactions between operational officers, technical government and industry researchers and academics is essential, in my opinion, to define clearly both short term and long term basic research in C^3 systems. This particular workshop was successful in bringing to the attention of the academic community many of the operational issues. As expected there was heavy participation from the faculty and students at the Naval Postgraduate School.

The consensus of the workshop was that the distributed information and decision nature of C^3 problems, coupled with their reliability and security requirements, present a great challenge to systems, control, communications, and computer scientists and engineers. It was self-evident that very little fundamental thinking has been done at the system level, and that a great deal of basic research has to be carried out to identify and solve the theoretical and technological problems that contribute to the deficiencies of current military C^3 systems.

For the sake of completeness, each report contains a table of contents for all four reports. The sequence of presentations is alphabetical and does not coincide with the order of the presentations at the workshop (which is also included in each volume).

The third MIT/ONR Workshop on the same topic will be held from Tuesday May 27 to Friday June 6, 1980 at the Holiday Inn, Silver Spring Plaza,

8777 Georgia Avenue, Silver Spring, Maryland. For additional details, you can contact the undersigned.

Michael Athans
Professor of Systems Science and Engineering
Director, Laboratory for Information and
Decision Systems
Massachusetts Institute of Technology
Cambridge, Massachusetts 02139

February 1, 1980

ACKNOWLEDGMENT

In addition to the workshop speakers and participants, I wish to thank Dr. Stuart Brodsky of the Office of Naval Research, Professor John M. Wozen-craft and Ms. Zanie Bactad of the Naval Postgraduate School, Professor Wilbur B. Davenport Jr., Mr. Richard A. Osborne, Ms. Barbara Peacock-Coady, and Ms. Leni F. Gross of the M.I.T. Laboratory for Information and Decision Systems for their help that made the workshop a success.

FINAL PROGRAM

MONDAY, July 16, 1979

- 8:00-9:00 REGISTRATION, Ingersol 202, Naval Postgraduate School
- 9:00-9:30 INTRODUCTION/WELCOME
Michael Athans, Massachusetts Institute of Technology,
Laboratory for Information and Decision Systems,
Cambridge, MA 02139 and
Stuart L. Brodsky, Code 432, Room 607, Office of Naval
Research, Arlington, VA 22217
- 9:30-11:00 THE STATE VARIABLES OF A COMMAND CONTROL SYSTEM
Joel S. Lawson, Jr., Technical Director, Naval Elec-
tronic Systems Command, ELEX 00B, Department of the
Navy, Washington, DC 20360
- 11:00-12:00 AN OVERVIEW AND PROGRESS REPORT OF THE MIT/LIDS RESEARCH
ON C³ SYSTEMS
Michael Athans, Massachusetts Institute of Technology,
Laboratory for Information and Decision Systems,
Cambridge, MA 02139
- 12:00-1:30 LUNCH
- 1:30-3:00 CYBERNETICS MODELS OF SURVEILLANCE C³ SYSTEMS
Paul H. Moose, Naval Postgraduate School,
Monterey, CA
- 3:00-4:00 GENERALIZED COUNTERMEASURE CONCEPTS IN C³
Thomas P. Rona, Staff Scientist, Boeing Aerospace
Company, P.O. Box 3999, Mail Stop 84-56, Seattle,
WA 98124

TUESDAY, July 17, 1979

- 8:30-9:30 COMMAND, CONTROL AND COMMUNICATION - SOME DESIGN ASPECTS
Daniel Schutzer, Technical Director, Naval Electronic
Systems Command, PME 108T, Washington, DC 20360
- 9:30-10:30 AN APPROACH TO THE EVALUATION OF TECHNOLOGY FOR UTILIZA-
TION IN NAVY COMMAND CONTROL AND COMMUNICATIONS
Scott Harmon, Technology Assessor, Naval Ocean Systems
Center, Code 832, 271 Catalina Boulevard, San Diego,
CA 92152
- 10:30-11:00 BREAK
- 11:00-12:00 SURVEILLANCE AND TRACKING PROBLEMS IN NAVAL C³ SYSTEMS
Nils R. Sandell, Jr., Massachusetts Institute of Tech-
nology, Laboratory for Information and Decision Systems,
35-336, Cambridge, MA 02139 and President, ALPHATECH, Inc.,
3 New England Executive Park, Burlington, MA 01803

TUESDAY, July 17, 1979 (continued)

12:00-1:30 LUNCH

1:30-5:00 AN OVERVIEW OF AMPHIBIOUS DOCTRINE AND OPERATION
Ed Boyd, Lt. Col. USMC, CDSA Dev. Ctr. MCDEC,
Quantico, VA 22134

WEDNESDAY, July 18, 1979

8:30-9:30 RESOURCE ALLOCATION FOR NAVAL PLATFORMS AND WEAPONS
Richard P. Wishner, Systems Control Inc., 1801 Page
Mill Road, Palo Alto, CA 94022

9:30-10:30 DECISION AIDS FOR OPERATIONAL DECEPTION
Al Clarkson, Manager, Warning and Crisis Management Group,
ESL Inc., 495 Java Drive, Sunnyvale, CA 94086

10:30-11:00 BREAK

11:00-12:00 DISTRIBUTED DECISION MAKING WITH LIMITED COMMUNICATIONS
Robert R. Tenney, Laboratory for Information and Decision
Systems, Massachusetts Institute of Technology, 35-213,
Cambridge, MA 02139

12:00-1:30 LUNCH

1:30-2:30 C³ CURRICULUM AT NAVAL POSTGRADUATE SCHOOL
John M. Wozencraft, Naval Postgraduate School, Monterey,
CA 93940

2:30-3:30 PRELIMINARY THOUGHTS ON C³ SYSTEM MODELING AND SURVIVABILITY
Stephen Kahne, Case Western Reserve University, Systems
Engineering, Cleveland, OH 44106

3:30-4:30 SOME SYSTEM PARAMETERS and A NOTE ON COMMAND STRUCTURES
Joel S. Lawson, Technical Director, Naval Electronic Systems
Command

THURSDAY, July 19, 1979

8:30-10:30 MARINE TACTICAL COMMAND AND CONTROL SYSTEM and
MARINE LANDING FORCE INTEGRATED³ COMMUNICATION SYSTEMS
J.V. Bronson, Lt. Col. USMC, C³ Division MCDEC,
Quantico, VA 22134

10:30-11:00 BREAK

11:00-12:00 COMMENTS ON THE SEACON 79-1 WAR GAME
Gerald E. Thomas, Rear Admiral, USN, COMTRAPAC,
San Diego, CA

THURSDAY, July 19, 1979 (continued)

12:00-1:30 LUNCH

1:30-5:00 DISCUSSION SESSION WITH ADMIRAL THOMAS

FRIDAY, July 20, 1979

8:30-9:30 THE MODELING OF NETWORKS WITH RADIO LINKS AS APPLIED
TO C³ SYSTEMS
Adrian Segall, Associate Professor, Department of Electrical
Engineering, Technion, Israel Institute of Technology,
Haifa, ISRAEL 3200

9:30-10:30 TACTICAL SITUATION ASSESSMENT USING A RULE-BASED INFERENCE
SYSTEM
Dennis C. McCall, Mathematician, Code 8242, Naval Ocean
Systems Center, San Diego, CA 92152

10:30-11:00 BREAK

11:00-12:00 THE DATA FUSION PROBLEM AND ITS RELEVANCE FOR THE MODELING
AND TRACKING OF MANEUVERING TARGETS
Bernard C. Levy and David Castanon, Research Scientists,
Laboratory for Information and Decision Systems, Massachu-
setts Institute of Technology, 35-316, Cambridge, MA 02139

MONDAY, July 23, 1979

8:00-8:30 REGISTRATION

8:30-9:30 HALTING THE PROLIFERATION OF ERRORS - AN APPLICATION FOR
ARTIFICIAL INTELLIGENCE
Gerald Wilson, Senior Computer Scientist, Computer Corpora-
tion of America, 575 Technology Square, Cambridge, MA 02139

9:30-10:30 REDISTRIBUTION OF FORCES
John M. Wozencraft, Naval Postgraduate School, Monterey,
CA 93940

MONDAY, July 23, 1979 (continued)

10:30-11:00 BREAK

11:00-12:00 SOME THOUGHTS ON MODELING THE C^3 FUNCTION IN FORCE
EFFECTIVENESS
Michael Athans, Massachusetts Institute of Technology,
Laboratory for Information and Decision Systems,
Cambridge, MA 02139

12:00-1:00 LUNCH

1:00-2:00 THE ROLE OF OPTIMAL ROUTING IN MULTIPLATFORM NAVAL TASK
FORCE OPERATIONS
Anna Nagurney, Systems Analyst, Naval Underwater Systems
Center, Code 3524, Bldg. 1171/1, Newport, RI 02840

2:00-3:00 OVERVIEW OF RESEARCH ON PACKET RADIO NETWORKS
Pierre Humblet, Massachusetts Institute of Technology,
Laboratory for Information and Decision Systems,
Cambridge, MA 02139

3:00-3:30 BREAK

3:30-4:30 SOME THOUGHTS ON NAVY COMMAND CONTROLS TECHNOLOGY
Robert C. Kolb, Head, Tactical Command and Control
Division, Naval Ocean Systems Center, Code 824, San Diego,
CA 92152

TUESDAY, July 24, 1979

8:30-9:30 A DISTRIBUTED ALGORITHM FOR THE ASSIGNMENT
Dimitri P. Bertsekas, Associate Professor EECS, Laboratory
for Information and Decision Systems, Massachusetts Insti-
tute of Technology, Cambridge, MA 02139

9:30-10:30 RECENT STUDIES ON INTEGRATED VOICE/DATA COMMUNICATIONS
NETWORKS
Robert Berger, Staff Member, Massachusetts Institute of
Technology - Lincoln Laboratory, P.O. Box 73, Lexington,
MA 02173

10:30-11:00 BREAK

11:00-12:00 OPERATIONAL IMPACT OF COMMAND AND CONTROL
William A. Myers, III, Rear Admiral, U.S. Navy, DCOS
Operations Command and Control, CINCLANTFLT, Norfolk,
VA 23511

TUESDAY, July 24, 1979 (continued)

12:00-1:30 LUNCH

1:30-2:30 OPTIMAL SEARCH TRAJECTORIES FOR A SINGLE PLATFORM
David A. Castanon and Nils R. Sandell, Jr.,
Massachusetts Institute of Technology, Laboratory for
Information and Decision Systems, Cambridge, MA 02139

2:30-3:30 MODELLING COMMUNICATIONS AND COMBAT
K. Shumate, MCTSSA, Camp Pendleton, CA 92055

3:30-4:00 BREAK

4:00-5:00 MODELING THE INFLUENCE OF INFORMATION ON THE PROGRESS OF
CLASSICAL LANCHESTER COMBAT
Donald P. Gaver, Professor, Naval Postgraduate School,
264 Root Hall, Monterey, CA 93940

WEDNESDAY, July 25, 1979

8:30-9:30 A METHODOLOGY FOR APPRAISING THE COMBAT EFFECTIVENESS OF
THE C² SYSTEM (NCSS)
George Harris, Fleet Command Center Representative, CINPAC
Fleet, Code 34T, Pearl Harbor, Hawaii, 96860

9:30-1:30 DESIGN, ANALYSIS AND SIMULATION OF A DISTRIBUTED SENSOR
NETWORK
Richard T. Lacoss, Associate Group Leader, Massachusetts
Institute of Technology - Lincoln Laboratory, 42 Carleton
Street, Cambridge, MA 02139

10:30-11:00 BREAK

11:00-12:00 DECENTRALIZED DETECTION PROBLEMS
Robert R. Tenney and Nils R. Sandell, Jr., Massachusetts
Institute of Technology, Laboratory for Information and
Decision Systems, Cambridge, MA 02139

12:00-1:30 LUNCH

1:30-2:30 MULTI-SENSOR INTEGRATION ARCHITECTURE
Dean Lucas, Senior Scientist, Martin Marietta, P.O. Box 179
Denver, CO 80201

2:30-5:00 DISCUSSION

THURSDAY, July 26, 1979

- 8:30-9:30 FUZZY DATABASES
Charles Giardina, Singer-Kearfott, 150 Totowa Rd.
Wayne, NJ 07470
- 9:30-10:30 HIERARCHICAL ESTIMATION
C.Y. Chong, Assistant Professor, School of Electrical
Engineering, Georgia Institute of Technology, Atlanta,
GA 30332
- 10:30-11:00 BREAK
- 11:00-12:00 SOME APPLICATIONS OF THE THEORY OF RANDOM FIELDS TO THE
LOCATION OF RADARS AND OF COMMUNICATION NODES IN A HILLY
TERRAIN
Bernard C. Levy, Alan S. Willsky, and Martin Bello, Labora-
tory for Information and Decision Systems, Massachusetts
Institute of Technology, Cambridge, MA 02139
- 12:00-1:00 LUNCH
- 1:00-1:45 PROBLEMS IN DISTRIBUTED DATABASES
Victor Li and Wilbur B. Davenport, Laboratory for Information
and Decision Systems, Massachusetts Institute of Technology
Cambridge, MA 02139
- 1:45-2:30 POSSIBILITY THEORY
Lotfi A. Zadeh, Professor, University of California, Computer
Science Division, Berkeley, CA 94720
- 2:45-3:45 C³ DESIGN IMPLICATIONS FOR DISTRIBUTED DATA ANALYSIS AND
FUSION ACTIVITIES
Robert L. Blinkenberg, Project Engineering Mission Analysis,
The Aerospace Corp., Bldg. A1, 4011, P.O. Box 92957,
El Segundo, CA 90009
- 3:45-4:45 A DESIGN ENVIRONMENT FOR C³ DATA BASES
Michael Wilens, Data Base Systems Research Group, School
of Business Administration, University of Michigan,
Ann Arbor, MI 48109

END OF CONFERENCE

MIT/ONR WORKSHOP ON DISTRIBUTED INFORMATION AND DECISION SYSTEMS

MOTIVATED BY NAVAL C³ PROBLEMS

July 16, 1979 - July 27, 1979

ATTENDEES

Merle Andrew
Director of Math & Info. Sci.
AFOSR
Bolling Air Force Base
Washington, DC
202-767-5025

Uzi Ben-Yakov
Student, C³ Curriculum
Naval Postgraduate School
580-D Wilkes Lane
Monterey, CA 93940
(408) 372-4670

Michael Athans
Director, Laboratory for Information
and Decision Systems
Massachusetts Institute of Technology
Room 35-304
Cambridge, MA 02139
(617) 253-6173

Robert Berger
Staff Member
MIT Lincoln Laboratory
P.O. Box 73
Lexington, MA 02173
(617) 862-5500 x7014

Michael Bayer
Student, C³ Curriculum
Naval Postgraduate School
1140 Spruance Road
Monterey, CA 93940
(408) 646-0630

Dimitri Bertsekas
Associate Professor
Laboratory for Information and
Decision Systems
Massachusetts Institute of Technology
Room 35-209
(617) 253-7267

Glen T. Beauchamp
Colonel, USMC
Chief, Concepts, Doctrine and
Studies Activity
Dev. Ctr.
CDSA, Dev. Ctr. MCDEC -
Quantico, VA 22134
(703) 640-2433 AV 278-2433

Robert Blinkenberg
Project Manager
Aerospace Corporation
P.O. Box 92957 (A-1,4011)
El Segundo, CA 90009
(213) 648-7506

S.J. Benkoski
Senior Associate
D.H. Wagner, Associates
Station Square One
Paoli, PA
(215) 644-2400

Paul L. Bongiovanni
NUSC, Code 3524, Bldg. 1171
Newport, RI 02840
(401) 841-2613

Ed Boyd
Lt. Col. USMC
CDSA Dev. Ctr. MCDEC
Quantico, VA 22134
(703) 640-2871

Michael J. Bradley
Captain, USA
Student, C³ Curriculum
Naval Postgraduate School
SMC 2812, NPS
Monterey, CA 93940
(408) 646-8198

Dr. J. Bram
AFOSR
Bolling Air Force Base
Washington, DC
(202) 767-4939

Dr. Stuart L. Brodsky
ONR
800 N. Quincy Street
Arlington, VA 22217
(202) 696-4362

J.V. Bronson
Lt. Col. USMC
C³ Div. MCDEC
Quantico, VA 22134
AV 278-2645

Frank R. Brown
Program Manager
Cubic Corp.
9333 Balboa Ave.

(714) 277-6780

LCDR. Richard M. Brown
Naval Intel.
USNAM Naval Postgraduate School
SMC Box #1872
Monterey, CA 93940
(408) 646-2228

Capt. J.A. Byrne, Jr., USN
ACOS TRA OPS
COMTRAPAC
San Diego, CA 92147
(714) 225-3401

Louis J. Casamayon
Student, C³ Curriculum
Naval Postgraduate School
SMC 2880
Monterey, CA 93940
(408) 372-9225

David Castanon
Research Staff
Laboratory for Information and
Decision Systems
Massachusetts Institute of Technology
Room 35-331
Cambridge, MA 02139
(617) 253-2125

Lawrence J. Cavaiola
LCDR, USN
Naval Postgraduate School (Code 55cb)
Monterey, CA 93940
(408) 646-2187

C.Y. Chong
Assistant Professor
Georgia Institute of Technology
Atlanta, GA
(404) 894-2994

S.I. Chou
Electronics Engineer
Naval Ocean Systems Center
San Diego, CA 92152
(714) 225-7788

B.E. Clark
Col. USMC
ONR
Arlington, VA
(202) 696-4274

Al Clarkson
Manager, Warning/Crisis Management
Research
ESL, Inc.
495 Java Drive
Sunnyvale, CA 94086
(408) 734-2244 x5546

John H. Cushman
LTG US Army (Ret)
Consultant, Mitre Corporation
91 Warwick Road
Bronxville, NY 10708
(914) 961-5919

R.N. Forrest
Professor
Naval Postgraduate School
Code 55 Fo
Monterey, CA 93940
(408) 646-7653

Wilbur B. Davenport, Jr.
Professor, Electrical Engineering
and Computer Science
Laboratory for Information and
Decision Systems
Massachusetts Institute of Technology
Room 35-214
Cambridge, MA 02139
(617) 253-2150

Donald P. Gaver
Professor
Naval Postgraduate School
264 Root Hall
Monterey, CA 93940
(408) 646-2605

Michael T. Dawson
Cpt. US Army
Naval Postgraduate School
389 E. Ricketts Road
Monterey, CA 93940

C.R. Giardina
Professor
Singer-Kearfott
Wayne, NJ
(201) 256-4000

Suchitra Dhar
Logician
S.R.I. International
333 Ravenswood Ave.
Menlo Park, CA 94025
(415) 326-6200 x5515

Robert D. Gordon
Student, C³ Curriculum
Naval Postgraduate School
379 Bergin Dr.
Monterey, CA 93940
(408) 649-6836

Fred Diamond
Tech. Dir., Comm. & Control Div.
RADC
Griffiss AFB, NY
(315) 330-4114

Norman K. Green, Jr.
Lt. USN
Naval Postgraduate School
SMC Box #1427
Monterey, CA 93940
(408) 646-9726

Leo J. Faneuf, III
LCDR, USN
Student, C³ Curriculum
Naval Postgraduate School
SMC 1630
Monterey, CA 93940
(408) 373-5470

Capt. S.L. Guille, USN
Commander, Naval Ocean Systems Center
NOSC
San Diego, CA 92152
(714) 225-8684

H.J. Feeney III
Marine Corps Office NOSC
Naval Ocean Systems Center
Code 033
San Diego, CA 92152
AV 933-6764/5 (714) 225-6764

Ronald L. Hard
LT. US Navy
Student, C³ Curriculum
Naval Postgraduate School
1095 Spruance Road
Monterey, CA 93940
(408) 646-9570

Scott Harmon
Technology Assessor
Naval Ocean Systems Center
Code 832
San Diego, CA 92152
(714) 225-2083

George Harris
Code 34T
Fleet Command Center Representative
C/o CINCPACFLT Staff
Pearl Harbor, HI
(808) 471-8636

Don E. Harrison, Jr.
Prof. of Physics
Naval Postgraduate School
61Hx
(408) 646-2877

Richard S. Hartman
Chief C³ Div.
Dev. Ctr. USMC CDEC
Quantico, VA 22134
(703) 640-2829

Laurie Henrikson
Manager, Systems Analysis
The Aerospace Corporation
P.O. Box 92957
Los Angeles, CA 90009
(213) 648-6832

Dr. R. Herbig
Adj. Res. Professor
Naval Postgraduate School
56 Hi
Monterey, CA 93940
(408) 646-2722

Ray Hershman
Research Psychologist
Navy Pers. R&D Center
Code P305
San Diego, CA 92152
(714) 225-2081

Kathryn D. Hogue
Student, C³ Curriculum
Naval Postgraduate School
Box 1122
Monterey, CA 93940
(408) 646-0936

Linda B. Hollowell
Student, C³ Curriculum
Naval Postgraduate School
SMC 2539
Monterey, CA 93940

Stacy V. Holmes
CDR, USN
Office of Naval Research
800 N. Quincy
Arlington, VA 22217
(202) 696-4713

Dr. Reiner K. Huber
Professor
Hochschule Der Bundeswehr Munchen
8014 Neubiberg
WEST GERMANY

Pierre A. Humblet
Assistant Professor
Laboratory for Information and
Decision Systems
Massachusetts Institute of Technology
Room 35-203
Cambridge, MA 02139
(617) 253-7250

Dr. Richard Jaffee
Naval Ocean Systems Center
Code 722
San Diego, CA 92152
(714) 225-2014

Cdr. Ronald James
Director Naval Analysis Programs
ONR
800 N. Quincy St.
Arlington, VA 22217
(202) 696-4319

Toke Jayachandran
Professor
Naval Postgraduate School
Mathematics Department
Monterey, CA 93940
(408) 646-2600

S.C. Jennings
Student, C³ Curriculum
Naval Postgraduate School
SMC #2409
Monterey, CA 93940
(408) 646-2772

LTC Fred Johnston
Student, C³ Curriculum
Naval Postgraduate School
SMC #1317
Monterey, CA 93940
(408) 646-9073

Mark Joseph
Program Manager
Systems of Applied Sciences
P.O. Box 5186
Kent, Washington
(206) 854-3637

Stephen Kahne
Professor & Chairman, Systems
Engineering
Case Western Reserve University
Cleveland, OH 44106
(216) 368-4466

Dr. Richard T. Kelly
Research Psychologist
Navy Personnel R&D Center
Code P305
San Diego, CA
(714) 225-2081

Dr. Garo K. Kiremidjian
Senior Member of Tech. Staff
ESL, Inc.
495 Java Dr.
Sunnyvale, CA 94086
(408) 734-2244, x5109

Donald E. Kirk
Chairman, Electrical Engineering Dept.
Naval Postgraduate School
Monterey, CA 93940
(408) 646-2081

Robert C. Kolb
Division Head
Naval Ocean Systems Center (NOXC)
San Diego, CA 92152
(714) 225-6176

Richard T. Lacoss
Assoc. Group Ldr.
MIT Lincoln Laboratory
P.O. Box 73
Lexington, MA 02138
(617) 253-7858

James Lane,³
Student, C³ Curriculum
Naval Postgraduate School
119 Moreell Cr.
Monterey, CA 93940
(408) 649-8974

Joel S. Lawson
Technical Director
NAVELEX
Washington, DC 20360
(202) 692-8960

Dan Leonard
Electronic Engr.
NOSC, Code 8105
San Diego, CA 92152
(714) 225-7093

Alexander H. Levis
Senior Research Scientist
Laboratory for Information and
Decision Systems
Massachusetts Institute of Technology
35-410
Cambridge, MA 02139
(617) 253-7262

Bernard Levy
Assistant Professor
Laboratory for Information and
Decision Systems
Massachusetts Institute of Technology
35-229
Cambridge, MA 02139
(617) 253-7269

Victor Li
Student
Laboratory for Information and
Decision Systems
Massachusetts Institute of Technology
35-329B
Cambridge, MA 02139
(617) 253-7264

Dean Lucas
Senior Scientist
Martin Marietta
P.O. Box 179
Denver, CO 80201
(303) 973-5659

Edmund A. Lucke
Capt. USMC₃
Student, C³ Curriculum
Naval Postgraduate School
114 Brownell Circle,
Monterey, CA 93940
(408) 372-6708

Robert Lundegard
Dir. Math & Info Sciences
Office of Naval Research
Arlington, VA 22217
(202) 696-4310

F.M. Manrod
Col. USMC
Chf Int Dir., MCDEC (Dev Ctr)
Quantico, VA 22134
AV 278-2581

Dennis C. McCall
Mathematician
NOSC
San Diego, CA 92152
(714) 225-7778 AV 933-7778

John R. Miller
Mgr. C³I Dept. - TAC RECON Directorate
ESL Inc.
495 Java Drive
Sunnyvale, CA 94086
(408) 734-2244 x5376

Prof. Paul H. Moose
Naval Postgraduate School
Monterey, CA 93940
(408) 649-2838

Martin Morf
Professor
Stanford University
Durand 109
Stanford, CA 94305
(415) 497-3798

John S. Morrison
Student, C³ Curriculum
Naval Postgraduate School
JCS91 (C³)
659 Hillcrest Ave.
Pacific Grove, CA 93950
(408) 649-4706

Thomas O. Mottl
Member of Tech. Staff
The Analytic Sciences Corp.
6 Jacob Way
Reading, MA
(617) 944-6850 x295

Frank Murphy
Curricular Officer, C³ Program
Naval Postgraduate School
Code 39
Monterey, CA 93940
(408) 646-2772 AV 878-2772

T.A. Summers
LCDR USN
Naval Postgraduate School
11 Rever Road
Monterey, CA 93940
(408) 372-1926

C.D. Taylor
USN
Naval Postgraduate School
SMC Box 1928
Monterey, CA 93940
(408) 646-2228

Robert Tenney
Assistant Professor
Laboratory for Information and
Decision Systems
Massachusetts Institute of Technology
Room 35-213
Cambridge, MA 02139
(617) 253-2359

Admiral G.E. Thomas, USN
COMTRAPAC
USN
San Diego, CA 92147
(714) 225-3401

Hal Titus
Professor
Naval Postgraduate School
Monterey, CA 93940
(408) 646-2560

Joel Trimble
Engineer
ONR
Code 221
Arlington, VA 22217

Edison Tse
Associate Professor
Department of Engineering - Economic
Systems
Stanford University
Stanford, CA 94022
(415) 497-4777

Harry L. Van Trees
Principal Deputy ASD-C³I
OSD
Pentagon
Washington, DC
(202) 695-0348

David Warner
Senior Consultant
SCICON
49, Berners St.
London W1 ENGLAND
01-580-5599

Kenneth D. Watts
Captain USMC
OPM Position Location Reporting System
P.O. Box 3310 Bldg. 600
MSC 128
Fullerton, CA 92634
(714) 732-4283

Michael E. Wilens
Graduate Student Assistant
Database Systems Research Group
Graduate School of Bus. Admin.
Ann Arbor, MN 48109
(313) 763-1100

Gerald A. Wilson
Senior Computer Scientist
Computer Corporation of America
575 Technology Square
Cambridge, MA 02139
(617) 491-3670

Richard P. Wishner
Vice President
Systems Control Inc.
1551 Awalt Ct.
Los Altos, CA 94022
(415) 969-9786

K.E. Woehler
Professor of Physics, Chairman
Physics Department
Naval Postgraduate School
Monterey, CA 93940
(408) 646-2486

W.M. Woods
Director, Office of Continuing Education
Naval Postgraduate School
Code 50D
Monterey, CA 93940
AV 878-2558

John M. Wozencraft
Professor, Chairman of the Academic Group for C³
Naval Postgraduate School
Monterey, CA 93940
(408) 646-2535

Jin Y. Yen
Adjunct Professor
Naval Postgraduate School
1037 Broncho Rd.
Pebble Beach, CA 93953
(408) 375-3284

Lotfi A. Zadeh
Professor
University of California
Computer Science Division
Berkeley, CA 94720
(415) 642-4959

TABLE OF CONTENTS

VOLUME I (LIDS-R-966)

M. ATHANS, Overview of MIT/LIDS Research in Naval C ³ Systems	p. 1
M. ATHANS, Some Thoughts on Modeling the C ³ Function in Force Effectiveness	p. 35
R. BERGER, Recent Studies on Integrated Voice/Data Communication	p. 54
E. GAFNI and D. BERTSEKAS, Distributed Algorithms for Maintaining Loopfree Communication in Data Networks with Frequently Changing Topology	p. 107
R. BLINKENBERG, Command, Control, and Communication (C ³) Design Implications for Distributed Data Analysis and Fusion Activities	p. 134
LT. COL. E. H. BOYD, An Overview of Amphibious Doctrine and Operations	p. 158
D. CASTANON and N. R. SANDELL, JR., Optimal Search Trajectories for a Single Platform	p. 201
C. CHONG, Hierarchical Estimation	p. 204
A. CLARKSON, Decision Aid for Operational Deception	p. 221

VOLUME II (LIDS-R-967)

D. P. GAVER, Modeling the Influence of Information on the Progress of Combat	p. 256
S. HARMON, An Approach to the Evaluation of Technology for Utilization in Navy Command Control and Communications	p. 286
G. HARRIS, A Methodology for Appraising the Combat Effectiveness of the Navy Command and Control System	p. 336
S. KAHNE, Preliminary Thoughts on C ³ System Modeling and Survivability	p. 379
R. C. KOLB, Some Thoughts on Navy Command and Control Technology Base Development	p. 389
R. LACOSS and P. GREEN, Design, Analysis and Simulation of a Distributed Surveillance Network	p. 409
J. S. LAWSON, The State Variables of a Command Control System	p. 462

VOLUME III (LIDS-R-968)

B. LEVY, A. WILLISKY, M. BELLO, Some Applications of the Theory of Random Fields to C ³ Problems	p. 511
V.O.K. LI, W.B. DAVENPORT, JR., Problems of Distributed Databases	p. 571
D. C. MC CALL, Tactical Situation Assessment Using a Rule-Based Inference System	p. 600

TABLE OF CONTENTS (Continued)

P. H. MOOSE, Cybernetic Models of Surveillance C ³ Systems	P. 620
A. B. NAGURNEY, The Role of Optimal Routing in Multiplatform Naval Task Force Operations	p. 643
T. P. RONA, Generalized Contermeasure Concepts in C ³ /I	p. 672

VOLUME IV (LIDS-R-969)

D. M. SCHUTZER, Command, Control and Communications - Some Design Aspects	p. 741
A. SEGALL, The Modeling of Networks with Radio Links as Applied to C ³ -Systems	p. 783
MAJOR K. C. SHUMATE, Modeling Communucations and Combat	p. 792
R. R. TENNEY, Distributed Decision Making with Limited Communication	p. 830
R. R. TENNEY, N. R. SANDELL, JR., Decentralized Detection Problems	p. 869
M. WILENS, A Design Environment for C ³ Databases	p. 901
G. A. WILSON, Halting the Proliferation of Errors	p. 922
J. M. WOZENCRAFT, Redistribution of Forces	p. 949

MODELING THE INFLUENCE OF INFORMATION ON THE PROGRESS OF COMBAT

Donald P. Gaver
Operations Research Department
Naval Postgraduate School
Monterey, California 93940
(408) 646-2605

MODELING THE INFLUENCE OF INFORMATION
ON THE PROGRESS OF COMBAT

by

Donald P. Gaver

1. INTRODUCTION

One neat way of describing the course of combat between two opposing military forces is in terms of the now classical Lanchester equations and their elaborations; see Taylor (1979) for a recent account. Recall that the Lanchester equations describe the changes in the opponent force sizes (e.g. numbers of tanks, ships, planes, or men) in terms of those force sizes (and, if desired, compositions) and general weapon effectiveness (acquisition and firing rate, probability of kill). That is, the state and prospect of the combat at any time is summarized in terms of the force sizes alone: the state of the system is taken to be the vector $\{R(t), B(t)\}$ where $R(t)$ is just the number of Reds surviving at t and $B(t)$ represents Blue survivors. Both $R(t)$ and $B(t)$ are commonly viewed as deterministic functions of time, but loosely speaking these functions can be regarded as the mean values of random processes; see for example Lehoczky and Perla (1978) for some stochastic versions. Despite the simplicity of such formulations, striking and plausible qualitative results are sometimes obtainable;

for instance we mention the "square law" that asserts the advantage of force concentration. That other physical parameters (e.g. speed of advance) may change matters is recognized by Bonder and Farrell (1970).

Combat models constructed along Lanchesterian lines have been subject to several sorts of criticism stemming from the simplicity of these models. The purpose of this paper is to point out that certain qualitative features of combat situations that seem to be only faintly and implicitly present in the present Lanchester formulations can be explicitly included to a suggestive degree. The specific reference here is to the influence of information upon combat progress. Moreover, the approach taken can probably be extended to remedy other sometimes mentioned modeling deficiencies.

It is widely recognized that information may have a decisive influence upon the progress of truly modern combat. Present day capability to gather, collate or "fuse," and disseminate information about an opponent's--and own force's--location, movements, and even state of information, could certainly not have been visualized in Lanchester's day or even later. It therefore seems imperative that the information states of the opposing forces be modeled so as to reflect the obvious leverage of information upon the outcome of physical combat, the result of which is the attrition (or withdrawal or redeployment, etc.) of Red and Blue forces.

The idea explored here is to expand the description of the state of the combat system in order to (i) recognize the effective differences in useful information possessed by members of the opposing forces, and (ii) to model the rate at which combat-effectiveness-enhancing information transfer occurs. As will be seen, the modeling technique used here resembles the classical Lanchesterian deterministic differential equation approach.

The technique can be "made stochastic" in various ways, but no attempt is made to do so here. The emphasis is on the formulation of the equations to describe the phenomena of information transfer as well as physical attrition; by and large, the interplay of these factors is investigated numerically and not analytically. There seems to be little point in glorifying explicit solutions for their own sakes unless their lessons are plain.

For some reason very little recognition has apparently been given to the similarity between military combat situations and models and situations and models of human or animal population interaction, e.g. the competition and predator-prey models of mathematical population biology; see Bartlett (1959), May (1973), and Hassell (1979). Comparisons may well be in order and be profitable to one and all. Likewise the approach taken here to consider multi-stated dynamic processes has long been used in chemical reaction theory and lately in

pharmacology, where "compartment models" are standard concepts, see Bischoff, Dedrick, and Zaharko (1971) and Gaver and Lehoczky (1977). Again it appears that interactions between investigators are timely, and may well be mutually advantageous and stimulating.

2. INFORMATION STATES: A SIMPLE EXAMPLE INVOLVING DEFENSE OF A STRONGHOLD

Suppose a force of size R attacks a bastion or stronghold defended by a force of size B . Assume that B suffers negligible attrition throughout the engagement, but the attacking R force experiences fire, and hence attrition, from B . We shall allow this attrition to depend upon the number of B 's that possess relevant information about R , and consequently upon the change in that number.

It may be reasonable to assume that initially B is ignorant of the precise location and status of the individual units of R . If so, it is appropriate to model R attrition as the result of area or unaimed fire by B :

$$\frac{dR(t)}{dt} = -\rho_u (R(t)/R)B \quad (2.1)$$

which is of course easily solved with B constant:

$$R(t) = R \exp[-\rho_u (B/R)t] \quad (2.2)$$

Note that the attrition thus predicted is sensitive to information available to B in at least two ways. First, equation (2.1) is based on general area fire by B; if proper designation of individual R units could be achieved, then R might actually be diminished in accordance with aimed fire, i.e. modeled by

$$\frac{dR}{dt} = -\rho_a B , \quad (2.3)$$

so

$$R(t) = R - B\rho_a t , \quad 0 \leq t \leq \frac{R}{\rho_a B} \quad (2.4)$$

$$= 0 , \quad \frac{R}{\rho_a B} \leq t$$

If the attrition parameter $\rho_a = \rho_u$ (it likely will not be) then the initial attrition rates are the same, but aimed fire is much more punishing to R as time advances, if the weapons and rate of fire are at all similar.

2.1. Information states

Let us model the affect of information upon Red attrition as follows. Divide the Blue forces into two groups: (i) those in the unaimed fire information state, and (ii) those in the aimed fire state; all Bs are in one state or the other. This affiliation is thought to be the result of possessing suitable information, and does not depend upon location (although terrain features may be important) or special equipment beyond what is needed to receive the information.

Let

$B_u(t)$ = number of Blues capable of executing unaimed
or area fire at time t , and

$B_a(t)$ = number of Blues capable of executing aimed
fire at t .

Hence we have

$$\begin{aligned}\frac{dR(t)}{dt} &= -\rho_u (R(t)/R) B_u(t) - \rho_a B_a(t) \\ &= -\rho_a B_a(t) - \rho \frac{R(t)}{R} (B - B_a(t)),\end{aligned}\quad (2.5)$$

assuming that B survives without attrition (at least initially)
and that all B s are in action. If (2.5) is written as follows,

$$\frac{dR}{dt} + \rho_u \frac{R(t)}{R} B_u(t) = -\rho_a B_a(t) \quad (2.6)$$

then it is easily integrable: apply the elementary integrating
factor technique

$$\frac{d}{dt} \left[R \exp \int_0^t \rho_u B_u(z) dz \right] = -\rho_a B_a(t) \exp \left[\int_0^t \rho_u B_u(z) dz \right],$$

which leads to the formal solution

$$\begin{aligned}R(t) &= R \exp \left[- \int_0^t R^{-1} \rho_u B_u(z) dz \right] \\ &\quad - \rho_a \int_0^t B_a(v) \exp \left[- \int_v^t R^{-1} \rho_u B_u(z) dz \right] dv,\end{aligned}\quad (2.7)$$

valid so long as the right-hand side is positive, and zero otherwise. Notice that if $B_u(t) \equiv B$, so no information is passed that allows conversion from unaimed to aimed fire, then (2.7) reduces to (2.1) for $B_a(t) \equiv 0$. On the other hand, suppose $B_a(t) \equiv B$ and $B_u(t) \equiv 0$, then (2.7) reduces to (2.3), the case of aimed fire, as is again proper. It is now of interest to trace the effect of some specific information flow mechanisms upon Red survivorship. It turns out that this is best done numerically, or even the simple closed-form solution (2.7) is virtually uninterpretable, and matters rapidly deteriorate further when more complex models appear.

2.2. Representations of Information Flow

Here are some possible representations for the change in the information states. They are so simple that the term "model" seems excessive. Note that no attempt is made to model the actual process of flow; the eventual impact upon $R(t)$ of the rate or timing of transition from unaimed to aimed fire is all that will be investigated for the present.

(A) Instantaneous transition.

Suppose

$$\begin{aligned} B_u(t) &= B, & 0 \leq t \leq \bar{t} \\ B_a(t) &= 0; \end{aligned} \tag{2.8}$$

while

$$\begin{aligned} B_u(t) &= 0 \\ B_a(t) &= B, & \bar{t} \leq t \end{aligned}$$

In other words, all B forces receive and profit from the required information instantly at time \bar{t} --possibly \bar{t} is the time at which a reconnaissance effort is completed and the results disseminated. Note, too, that the change could be the result of changed visibility for B, e.g. because of terrain changes (there is suddenly no cover) or because of weather effects, i.e. wind blowing away smoke.

It is easy to see from (1.7) that

$$R(t) = R \exp[-(\rho_u(B/R)t)] \quad , \quad 0 \leq t \leq \bar{t} \tag{2.9a}$$

$$= R \exp[-(\rho_u(B/R)\bar{t})] - \rho_a B(t-\bar{t}), \quad \bar{t} \leq t \tag{2.9b}$$

where the last expression is replaced by zero when it becomes negative.

(B) Instantaneous transition at a random time

This is merely a generalization of (A) that allows \bar{t} to be a random variable with distribution function $F(x)$. Unfortunately the condition that $R(t)$ be non-negative (see 1.9b) makes it awkward to compute the expectation of $R(t, \bar{t})$; a numerical root-finding step intervenes. No details as yet.

(C) Gradual transitions: First-order rate process

Suppose we can describe the effect of information transfer as follows

$$\frac{dB_a}{dt} = kB_u(t) = k(B - B_a(t)) \quad (2.10)$$

or, equivalently,

$$\frac{dB_u}{dt} = -kB_u(t) \quad (2.11)$$

Thus the rate of conversion to aimed fire is proportional to the number currently engaging in unaimed fire. Solutions are immediate:

$$\begin{aligned} B_u(t) &= B(0)e^{-kt} \equiv Be^{-kt} \\ B_a(t) &= B(1 - e^{-kt}) \end{aligned} \quad (2.12)$$

This is a classical "learning curve"--the larger k , the more rapid is the learning. Adoption of this model leads by specializing (2.7) to the expression $(R(0) \equiv R)$

$$R(t) = R \exp\left[-\int_0^t \rho_u B e^{-kz} dz\right] - \rho_a B \int_0^t (1-e^{-kv}) \exp\left[-\rho_u B \int_v^t e^{-kz} dz\right] dv$$

Simplification gives

$$\begin{aligned} R(t) &= R \exp\left[-\frac{\rho_u B}{k} (1-e^{-kt})\right] - \rho_a B \int_0^t (1-e^{-kv}) \exp\left(-\frac{\rho_u B}{k} [e^{-kv}-e^{-kt}]\right) dv \\ &= R \exp\left[-\frac{\rho_u B}{k} (1-e^{-kt})\right] \\ &\quad - \rho_a B \exp\left[\frac{\rho_u B}{k} e^{-kt}\right] \left\{ \int_0^t e^{-\alpha e^{-kv}} dv - \int_0^t e^{-\alpha e^{-kv}} e^{-kv} dv \right\} \quad (2.13) \end{aligned}$$

where $\alpha = \rho_u B/k$ for temporary convenience in the remaining integrals.

Next reduce the integrals to the degree apparently possible:

$$(i) \int_0^t e^{-\alpha e^{-kv}} dv = k^{-1} \int_{\alpha e^{-kt}}^{\alpha} e^{-x} \frac{dx}{x} = \frac{1}{k} [E_i(\alpha e^{-kt}) - E_i(\alpha)]$$

where $E_i(\cdot)$ is the exponential integral; see Abramowitz and Stegun (1965), where tabulations and approximations are given.

$$(ii) \int_0^t e^{-\alpha e^{-kv}} e^{-kv} dv = (k\alpha)^{-1} \int_{\alpha e^{-kt}}^{\alpha} e^{-x} dx = (k\alpha)^{-1} [e^{-\alpha e^{-kt}} - e^{-\alpha}]$$

Formula (2.13) expresses $R(t)$ entirely in terms of tabulated functions, so numerical solutions are in hand, in principle.

Alternatively, one could numerically solve (2.6) directly,

using standard algorithms for solving ordinary first-order

linear differential equations. Investigations of the sensitivity

of the solutions to changes in parameters--particularly k , the "learning rate"--can then be straightforwardly carried out. Such numerical solutions are far more comprehensible than the formulas presented above.

(D) Gradual transition: Linear Increase

For variety let

$$\begin{aligned} B_a(a) &= kt, & 0 \leq kt \leq B \\ &= B, & kt \geq B \end{aligned} \tag{2.14}$$

which can also be expressed in terms of a differential equation should one wish to. This model might reflect the way in which information traverses a linear network, taking into account deterministic delays but no errors in the "pass-it-on" process. Now substitute into (2.7) to capture $R(t)$:

$$\begin{aligned} R(t) &= R \exp\left(-\int_0^t \rho_u [B-kz] dz\right) - \rho_a \int_0^t kv \exp\left(-\int_v^t \rho_u [B-kz] dz\right) dv, \\ & & 0 \leq t \leq B/k \\ &= R \exp\left(-\int_0^{B/k} \rho_u [B-kz] dz\right) \\ &\quad - \rho_a \left\{ \int_0^{B/k} kv \exp\left(-\int_v^{B/k} \rho_u [B-kz] dz\right) dv \right. \\ &\quad \left. + \int_{B/k}^t B \exp\left(-\int_v^{B/k} \rho_u [B-kz] dz\right) dv \right\}, \quad B/k < t, \tag{2.14} \end{aligned}$$

with the usual proviso that $R(t) = 0$ if the right-hand side of the above expression becomes negative. Again everything can be integrated in tabulated form.

3. COMBAT AND INFORMATION UNDER CONDITIONS OF MUTUAL ATTRITION

In the last section we presented a model that illustrated information flow impact upon conflict. It was simplified so that explicit mathematical solutions were easily possible. Nevertheless, the solutions were hardly interpretable or comprehensible. Thus in this section the more conventional models that allow mutual attrition are re-examined, now numerically, with a view to tracing the effect of the comparative information-handling capabilities of the protagonists. Our numerical results suggest that the interplay between the physical (e.g. exchange rate) parameters and the information transfer parameters can indeed lead to quite interesting combat outcomes.

2.1. Information and Physical States

Once again the forces in conflict are classified as to whether they can accomplish unaimed or aimed fire (other classifications may be more meaningful, and can probably be identified). That is

$B_u(t)$ = number of Blue forces in unaimed state at time t ,

$B_a(t)$ = number of Blue forces in aimed state at time t ;

$R_u(t)$ and $R_a(t)$ are defined analogously. Now consider the following representative set of four simultaneous differential equations suggested to describe the change in the state vector $\{R_u(t), R_a(t), B_u(t), B_a(t)\}$:

$$\frac{dR_u}{dt} = -r_{ua} R_u(t) - \rho_u(R_u(t)/R)B_u(t) - \rho_a B_a(t) \left(\frac{R_u(t)}{R_a(t) + R_u(t)} \right) \quad (3.1a)$$

$$\frac{dR_a}{dt} = r_{ua} R_u(t) - \rho_u(R_a(t)/R)B_u(t) - \rho_a B_a(t) \left(\frac{R_a(t)}{R_a(t) + R_u(t)} \right) \quad (3.1b)$$

$$\frac{dB_u}{dt} = -b_{ua} B_a(t) - \eta_u(B_u(t)/B)R_u(t) - \eta_a R_a(t) \left(\frac{B_u(t)}{B_a(t) + B_u(t)} \right) \quad (3.1c)$$

$$\frac{dB_a}{dt} = b_{ua} B_u(t) - \eta_u(B_a(t)/B)R_u(t) - \eta_a R_a(t) \left(\frac{B_a(t)}{B_a(t) + B_u(t)} \right) \quad (3.1d)$$

The arguments used to derive these can be illustrated for, say, the first equation. They are analogous for those remaining.

- (i) The term $-r_{ua} R_u(t)$ in (3.1a)--see also b_{ua} in (3.1c)--represents the rate at which forces capable of unaimed fire shift to aimed fire capability; r_{ua} may be thought of as representing a rate of information transfer causing a change from an inaimed to an aimed capability. The particular mathematical form is likely to be quite incorrect in detail; a more appropriate one can be derived by careful consideration of intelligence and reconnaissance activity and information dissemination.

It is this term, or its elaboration, that is effected by ADP equipment, communication systems, and the like.

(ii) The term $-\rho_u (R_u(t)/R) B_u(t)$ represents the attrition of Red Unaimed forces by Blue Unaimed. It can be regarded as the result of writing

$$-\rho_u \left[\frac{R_a(t) + R_u(t)}{R} B_u(t) \right] \frac{R_u(t)}{R_a(t) + R_u(t)}$$

where the []-term is the classical unaimed fire term, with aimed and unaimed equally vulnerable, while $(R_u(t)/R_a + R_u)$ represents the probability that the recipient of fire is actually an unaimed Red element.

(iii) The term

$$-\rho_u B_a(t) \frac{R_u(t)}{R_a(t) + R_u(t)}$$

represents the attrition of Red Unaimed forces by Blue Aimed.

The parameters ρ_u and ρ_a represent physical attrition rates of Blue against Red, and the parameters η_u and η_a are the corresponding physical attrition rates for Red against B. Of course all of these can be rendered time dependent, or otherwise altered as desired.

MODELING THE INFLUENCE OF INFORMATION ON COMBAT

DONALD P. GAVER

OPERATIONS RESEARCH DEPARTMENT

NAVAL POSTGRADUATE SCHOOL

MONTEREY, CALIFORNIA

MIT/ONR WORKSHOP ON C³ SYSTEMS

JULY 1979

SETTING:

- COMBAT BETWEEN RED AND BLUE FORCES, RESULTING
IN MUTUAL ATTRITION.

- CLASSICAL STATUS OF COMBAT ACCOUNTING:

$R \equiv R(0)$: INITIAL NUMBER OF REDS IN COMBAT WITH BLUES

$R(\tau)(\leq R)$: RED FORCE AT $\tau > 0$

$B \equiv B(0)$: INITIAL BLUES

$B(\tau)(\leq B)$: BLUE FORCE SIZE AT τ

- $(B(\tau), R(\tau))$: SYSTEM STATE AT τ ;

- ENTIRELY PHYSICAL

CLASSICAL LANCHESTER DYNAMICS

- UNAIMED (AREA) FIRE
(DETERMINISTIC VERSION)

$$R(T+DT) = R(T) - \rho_U \left(\frac{R(T)}{R} \right) B(T) DT$$

IMPLIES

$$\frac{dR}{dT} = - \rho_U \left(\frac{R(T)}{R} \right) B(T)$$

- AIMED FIRE

$$R(T+DT) = R(T) - \rho_A B(T) DT$$

IMPLIES

$$\frac{dR}{dT} = - \rho_A B(T)$$

- SIMILAR FOR $B(T)$, WITH η_U, η_A
- ρ_U, ρ_A SAME DIMENSIONS
- INFINITELY GENERALIZABLE! TIME DEPENDENCE, STOCHASTIC VERSION, E.G. ITÖ-TYPE S.D.E., ETC.

IMPACT OF INFORMATION

- INFORMATION (ONE OPERATIONAL, NARROW, DEFINITION):
THAT DATA LEADING TO EFFECTIVE EMPLOYMENT OF FORCES

- EXAMPLE: LANCHESTER COMBAT; BLUE SYSTEM
 - $\rho_U < \rho_A$: BLUES SHOULD EMPLOY AIMED FIRE.

 - BLUES CAN ACQUIRE AND TRANSMIT INFORMATION ALLOWING AIMED FIRE (C³/I SYSTEM) AT A "CHARACTERISTIC RATE" (SUMMARY OF SYSTEM PERFORMANCE).

 - BLUE FORCES DIVIDE INTO TWO INFORMATION STATES:
 - $B_U(\tau)$ = NBR. CAPABLE OF UNAIMED FIRE.
 - $B_A(\tau)$ = NBR. CAPABLE OF AIMED FIRE.

NEW LANCHESTERIAN EQUATIONS

$$\frac{DR_U}{DT} = \underbrace{-R_{UA}R_U(\tau)} - \rho_{UU}\left(\frac{R_U(\tau)}{R}\right)B_U(\tau) - \rho_{AU}\left(\frac{R_U(\tau)}{R_A(\tau) + R_U(\tau)}\right)B_A(\tau)$$

$$\frac{DR_A}{DT} = \underbrace{-R_{UA}R_U(\tau)} - \rho_{UA}\left(\frac{R_A(\tau)}{R}\right)B_U(\tau) - \rho_{AA}\left(\frac{R_A(\tau)}{R_A(\tau) + R_U(\tau)}\right)B_A(\tau)$$

- ~~~~~ TERMS REPRESENT RATE OF CHANGE OF INFORMATION POSSESSED BY RED FORCES. (VASTLY SIMPLIFIED!)
- OTHER TERMS REPRESENT PHYSICAL CHANGES (ATTRITION) TO OCCUPANTS OF STATE CATEGORIES.
- SIMILAR MODEL FOR BLUES (TWO MORE EQUATIONS).
- ANALYTICAL SOLUTIONS TO (FOUR) EQUATIONS IMPOSSIBLE--COMPUTE RESULTS.
- STOCHASTIC VERSION (ITÖ EQUATIONS) POSSIBLE.

GUC

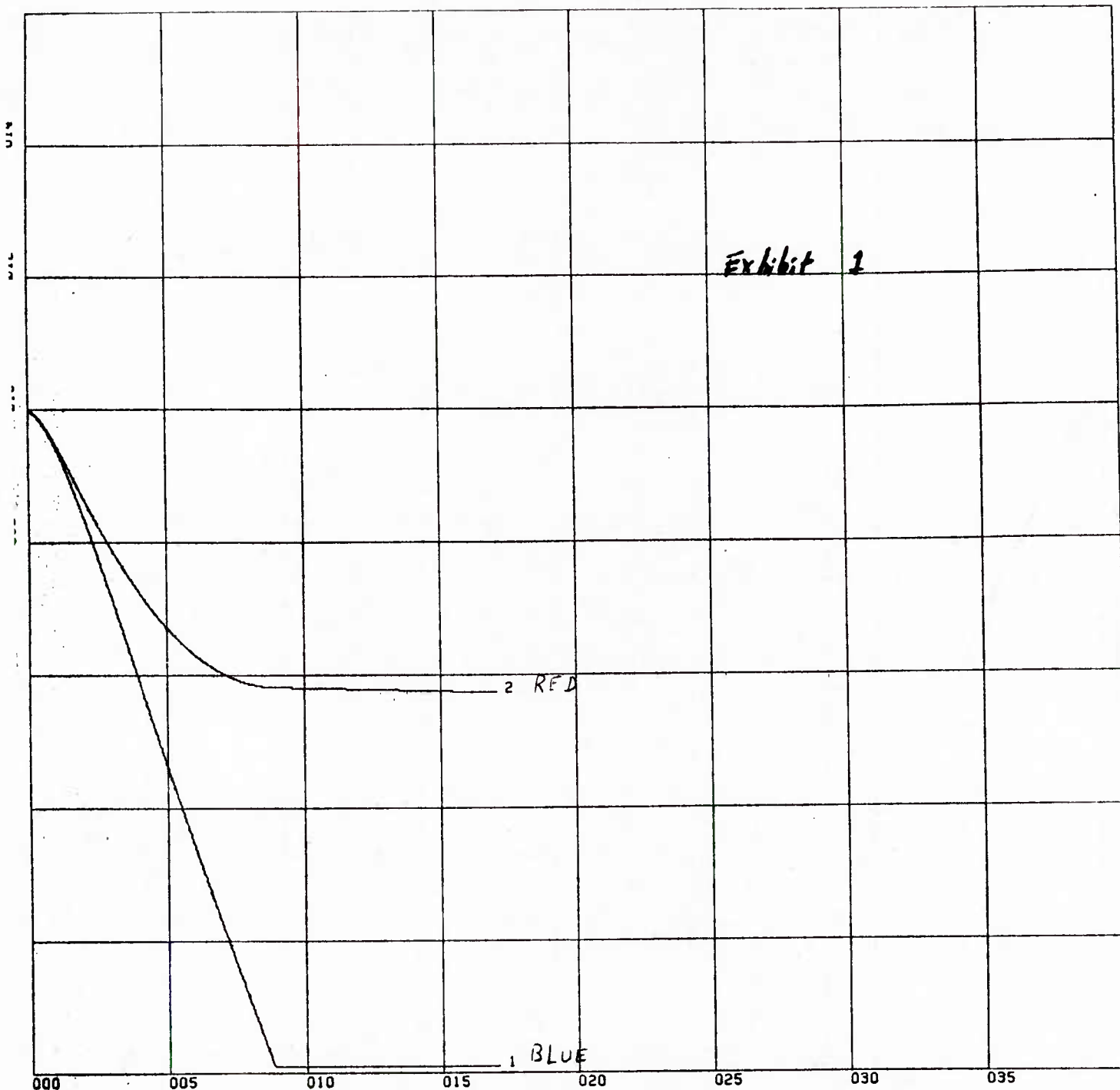

X-SCALE=5.00E+00 UNITS INCH.
 Y-SCALE=2.00E+01 UNITS INCH.

RUN 2

277 B AND R VS TIME

$r_{ua} = 0.5$

$b_{ua} = 1.5$

$\rho_u = 0.01$

$\eta_u = 0.02$

$\rho_a = 0.1$

$\eta_a = 0.2$

K . T

RED
 APART

RED
 APART

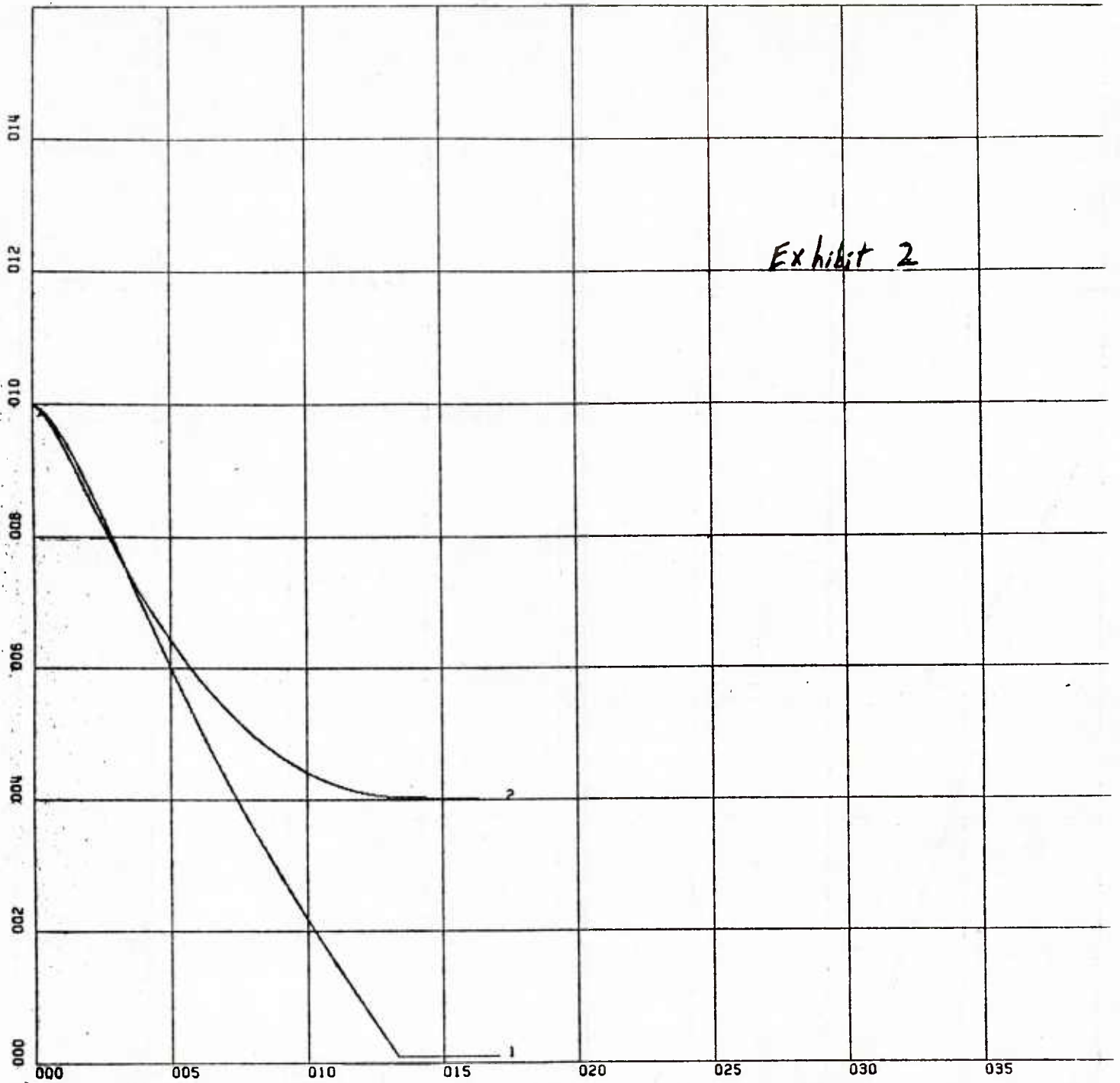

reel
reel

X-SCALE=5.00E+00 UNITS INCH.
Y-SCALE=2.00E+01 UNITS INCH.

$r_{ua} = 0.5$ $b_{ua} = 1.5$
 $\rho_u = 0.01$ $\eta_u = 0.015$
 $\rho_a = 0.1$ $\eta_a = 0.15$
 K . T

RUN 1 273 B AND R VS TIME

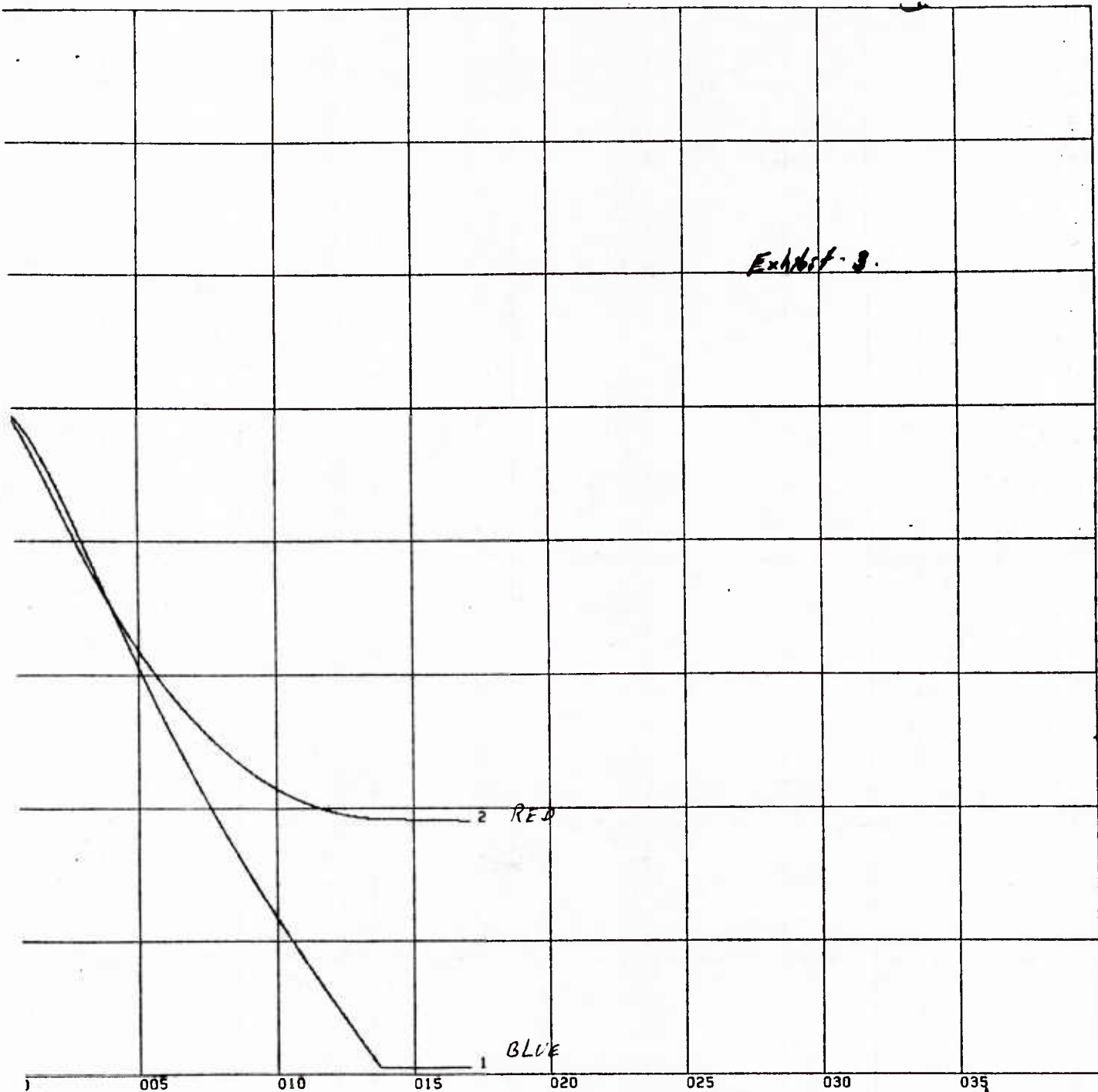

Exhibit 3.

2 RED

1 BLUE

-SCALE=5.00E+00 UNITS INCH.
 -SCALE=2.00E+01 UNITS INCH.

$$\rho_{ua} = 0.5$$

$$\rho_{ua} = 1.5$$

$$\rho_u = 0.015$$

$$\eta_u = 0.01$$

$$\rho_a = 0.1$$

$$\rho_a = 0.1$$

K . T (

RUN 3

B AND R VS TIME

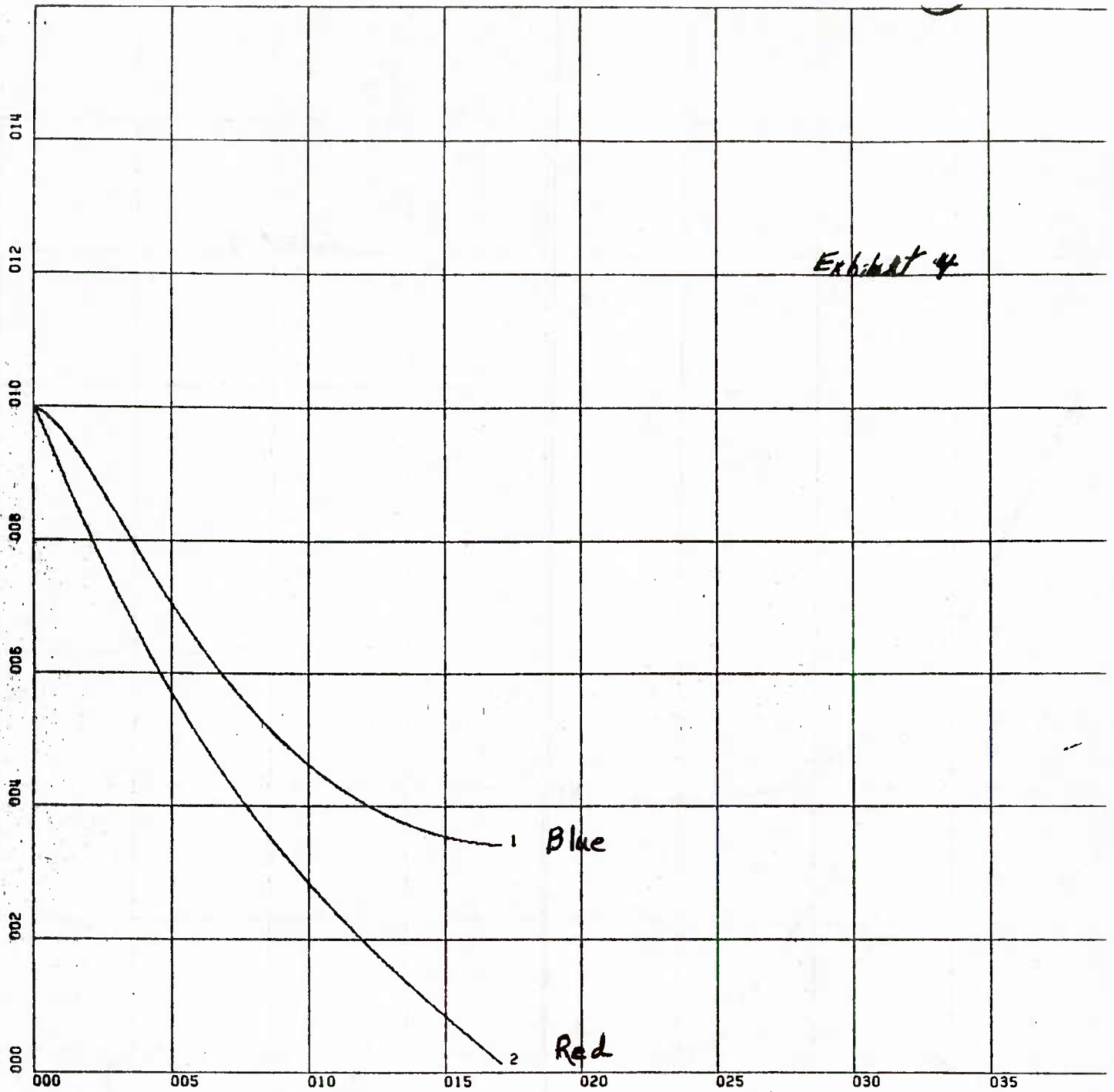

$$r_{ua} = 0.5$$

$$b_{ua} = 10$$

$$\rho_{ua} = 0.01$$

$$\eta_{ua} = 0.01$$

$$\rho'_{ua} = 0.1$$

$$\eta'_{ua} = 0.12$$

X-SCALE=5.00E+00 UNITS INCH.
 Y-SCALE=2.00E+01 UNITS INCH.

T U R K

RUN 5

B AND R VS TIME

250

Modifications for Aimed, Uncoordinated, Fire.

Aimed Fire (Classical):

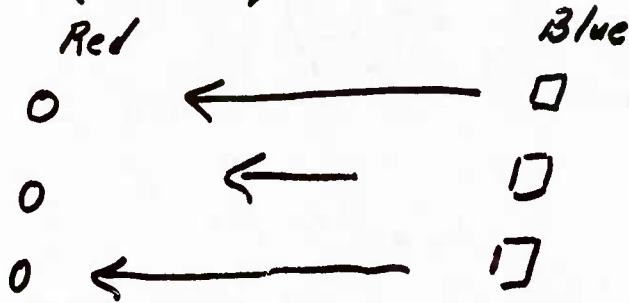

Aimed Fire (Uncoordinated)

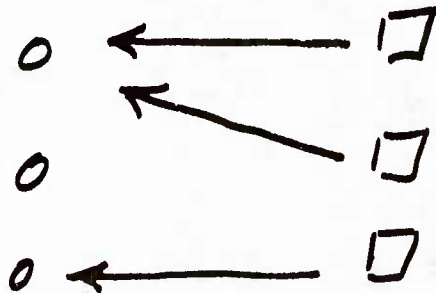

Expected # (different) Reds targeted by ^{Aimed} n Blues @ t :

$$[R_a(t) + R_u(t)] \left[1 - \left(1 - \frac{1}{R_a(t) + R_u(t)} \right)^{B_a(t)} \right]$$

Expected # " R_a 's" (Aimed Reds) targeted by ^{Aimed} n Blues @ t :
1st one only

$$\left[\frac{R_a(t)}{R_a(t) + R_u(t)} \right] [R_a(t) + R_u(t)] \left[1 - \left(1 - \left(\frac{1}{R_a(t) + R_u(t)} \right) \right)^{B_a(t)} \right]$$

Aimed - Un Coordinated Destruction Equations.

$$\frac{dR_A}{dt} = r_{UA} R_U(t) - P_{UA} \left(\frac{R_A(t)}{R} \right) B_U(t) -$$

$$\underbrace{- P_{AA} R_A(t) \left[1 - \left(1 - \frac{1}{R_A(t) + R_U(t)} \right)^{B_A(t)} \right]}$$

Etc.

Compare: Expand in Taylor Series; at $t \approx 0$, $B_U(t)$

small, \dots $\underbrace{\hspace{2cm}} \approx - P_{AA} R_A(t) \left[1 - \left(1 - \frac{B_A(t)}{R_A(t) + R_U(t)} \right) \right]$

$$= P_{AA} \left(\frac{R_A(t)}{R_A(t) + R_U(t)} \right) B_A(t).$$

Same as in Classical Coordinated Case (as should; too many targets per Blue to have significant overlap).

- Opportunity: introduce Coordination later in combat, or when aiming possible.

Exhibit 2'
 (Aimed - Uncoordinated)

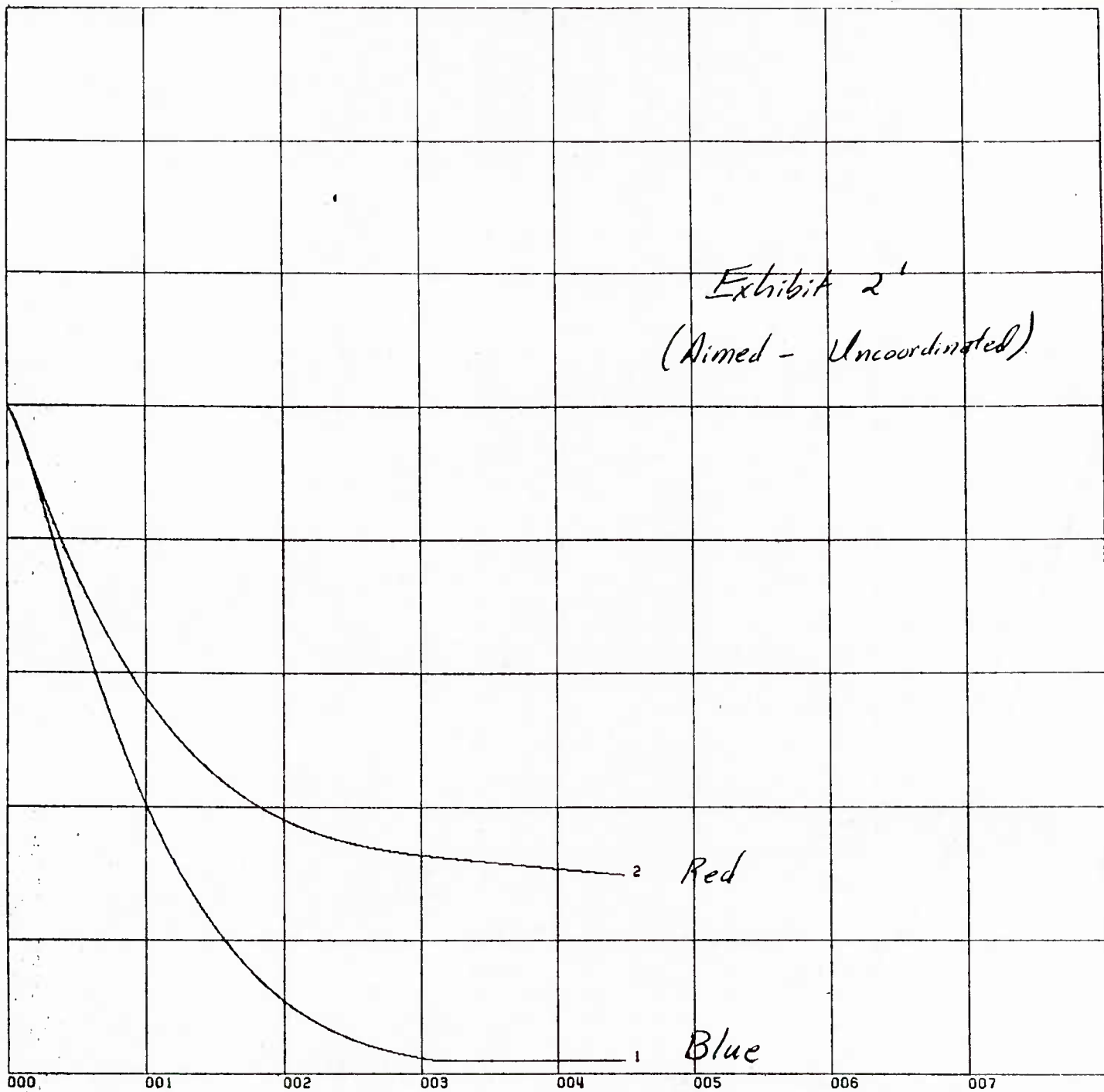

X-SCALE=1.00E+01 UNITS INCH.
 Y-SCALE=2.00E+01 UNITS INCH.

T U R K

RUN 1

B AND R VS TIME

283

$r_{ua} = 0.5$ $b_{ua} = 1.5$

$\rho_a = 0.01$; $\eta_a = 0.015$

$\rho'_a = 0.1$; $\eta'_a = 0.15$

Red
Attrition

Blue
Attrition

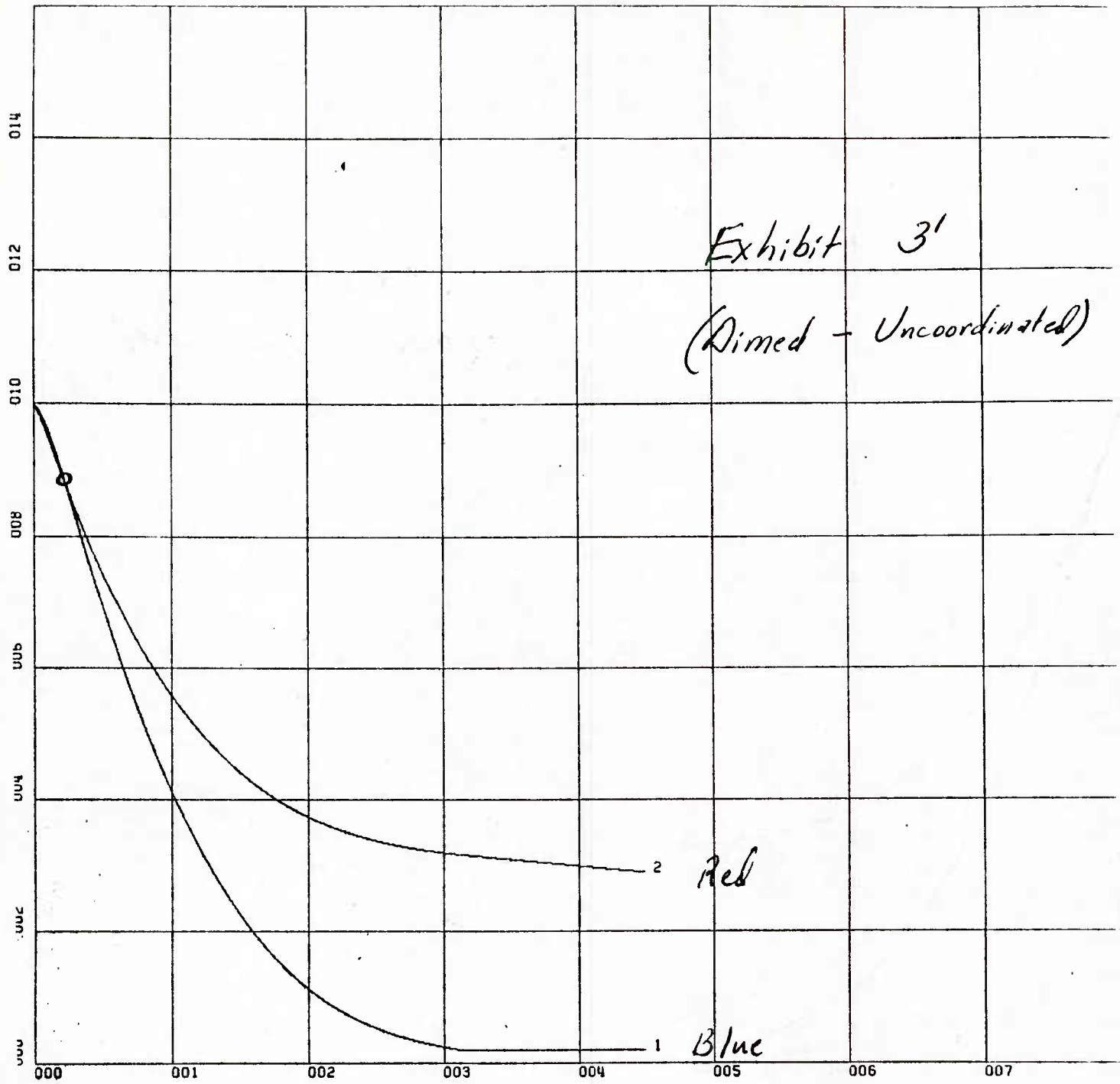

X-SCALE=1.00E+01 UNITS INCH.
 Y-SCALE=2.00E+01 UNITS INCH.

T U R K

RUN 4

284 B AND R VS TIME

$\rho_{un} = 0.5, b_{un} = 1.5$
 $\rho = 0.015; \eta_u = 0.0$
 $\rho' = 0.1; \eta_a = 0.1$
 Red Annit. Blue (by)

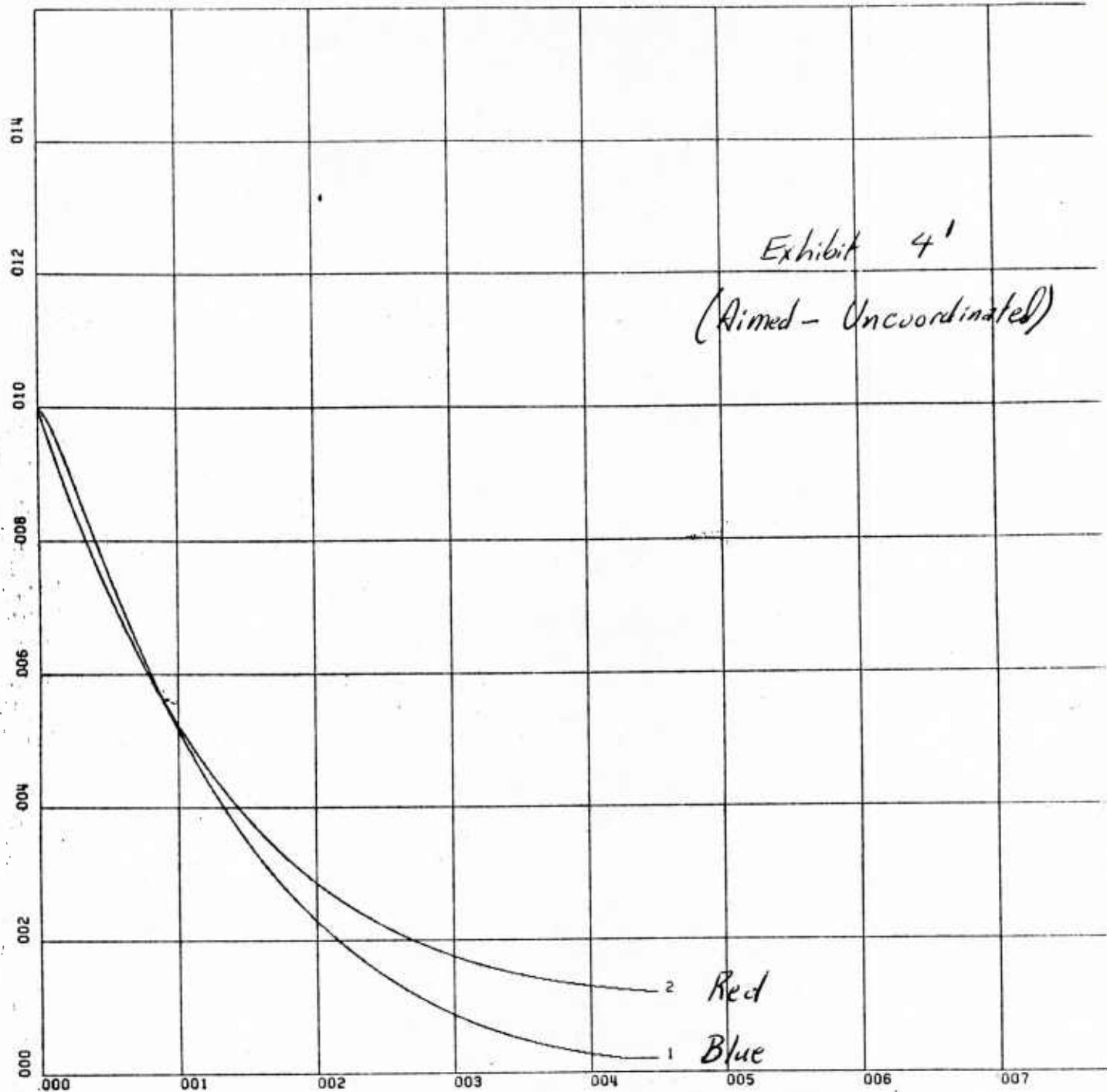

X-SCALE=1.00E+01 UNITS INCH.
 Y-SCALE=2.00E+01 UNITS INCH.

T U R K

RUN 5

B AND R VS TIME

285

$r_{ua} = 0.5$ $b_{ua} = 16$

$\rho = 0.01$ $\eta_m = 0.01$

$\rho' = 0.1$ $\eta_a = 0.12$

Red Attrit.

Blue Attrit

AN APPROACH TO THE EVALUATION OF TECHNOLOGY FOR UTILIZATION
IN NAVY COMMAND CONTROL AND COMMUNICATIONS

Scott Harmon
Naval Ocean Systems Center
Code 832
271 Catalina Boulevard
San Diego, California 92152
(617) 225-2083

OVERVIEW

TECHNOLOGY ASSESSMENT

HORIZONTAL TECHNOLOGY ASSESSMENT

VERTICAL TECHNOLOGY ASSESSMENT

C3 REFERENCE MODEL

ELEMENTARY THERMOPHYSICS CONCEPTS

ENERGY MODEL

DATA FLOW MODEL

TECHNOLOGY ASSESSMENT METHODOLOGY

HORIZONTAL TECHNOLOGY ASSESSMENT

PURPOSE- COLLECTION AND EVALUATION OF INFORMATION
CONCERNING TECHNOLOGIES APPLICABLE TO NAVY C3 FROM
A BROAD BUT SHALLOW PERSPECTIVE.

HORIZONTAL TECHNOLOGY ASSESSMENT

INFORMATION SOURCES

LIBRARY RESOURCES

ALERTS FROM SUCH DATABASES AS:

DDC

NTIS

SMITHSONIAN

SCIENCE CITATION INDEX

INSPEC

PERIODICAL REVIEW

CONFERENCE & WORKSHOP ATTENDANCE

HUMAN RESOURCES

HORIZONTAL TECHNOLOGY ASSESSMENT

INFORMATION SINKS

C2 TECHNOLOGY ASSESSMENT STATE OF THE ART REVIEWS
CONSISTS OF A QUARTERLY REPORT IN PERIODICAL FORMAT

VERTICAL TECHNOLOGY ASSESSMENT

PURPOSE- COLLECTION AND EVALUATION OF INFORMATION
CONCERNING TECHNOLOGIES APPLICABLE TO NAVY C3 FROM
A NARROW BUT IN-DEPTH PERSPECTIVE.

VERTICAL TECHNOLOGY ASSESSMENT

INFORMATION SOURCES

LIBRARY RESOURCES

SEARCHES OF SUCH DATABASES AS:

DDC

NTIS

SMITHSONIAN

SCIENCE CITATION INDEX

INSPEC

MAGAZINE INDEX

HUMAN RESOURCES

VERTICAL TECHNOLOGY ASSESSMENT

INFORMATION SINKS

VERTICAL TECHNOLOGY ASSESSMENT REPORTS

4 LEVELS OF CONSIDERATION AVAILABLE

- (1) BRIEF
- (2) SHALLOW ASSESSMENT
- (3) INTERMEDIATE ASSESSMENT
- (4) DEEP ASSESSMENT

THERMOPHYSICS CONCEPTS (THERMODYNAMICS)

2 FUNDAMENTAL CONCEPTS

(1) ENERGY FLUXES

(2) ENTROPY PRODUCTION

THERMOPHYSICS CONCEPTS

FIRST LAW OF THERMODYNAMICS (CONSERVATION OF ENERGY)

$$\frac{\partial u}{\partial t} + \nabla \cdot \vec{E} = 0$$

THERMOPHYSICS CONCEPTS

FIRST LAW RESTATED

$$\left[\begin{array}{c} \text{rate of change} \\ \text{of} \\ \text{stored energy} \end{array} \right] + \left[\begin{array}{c} \text{net} \\ \text{energy flux} \end{array} \right] = 0$$

YOU CAN'T WIN!

THERMOPHYSICS CONCEPTS

SECOND LAW OF THERMODYNAMICS (ENTROPY PRODUCTION)

$$\sigma \geq 0$$

THERMOPHYSICS CONCEPTS

SECOND LAW RESTATED

$$\left[\begin{array}{l} \text{net entropy} \\ \text{production} \end{array} \right] \geq 0$$

YOU CAN'T EVEN BREAK EVEN!

THERMOPHYSICS CONCEPTS

NONEQUILIBRIUM PROCESSES

$$\vec{E} \neq 0$$

THERMOPHYSICS CONCEPTS

IRREVERSIBLE PROCESSES

$$Q \neq 0$$

C³ REFERENCE MODEL

PURPOSE - QUANTITATIVE ASSESSMENT OF THE UTILITY OF
EMERGING TECHNOLOGY AS APPLIED TO NAVY C³ CAPABILITIES

ENERGY MODEL

FUNDAMENTAL CONCEPTS

FORCE = SYSTEM

ENERGY STORAGE = INTERNAL ENERGY

NONEQUILIBRIUM CONDITIONS

IRREVERSIBLE SITUATION

ENERGY MODEL

FIRST LEVEL COMPONENTS

- (1) OWN FORCE (SYSTEM)
- (2) SURROUNDINGS (EVERYTHING ELSE)

ENERGY MODEL

SINGLE FORCE ENERGY BALANCE

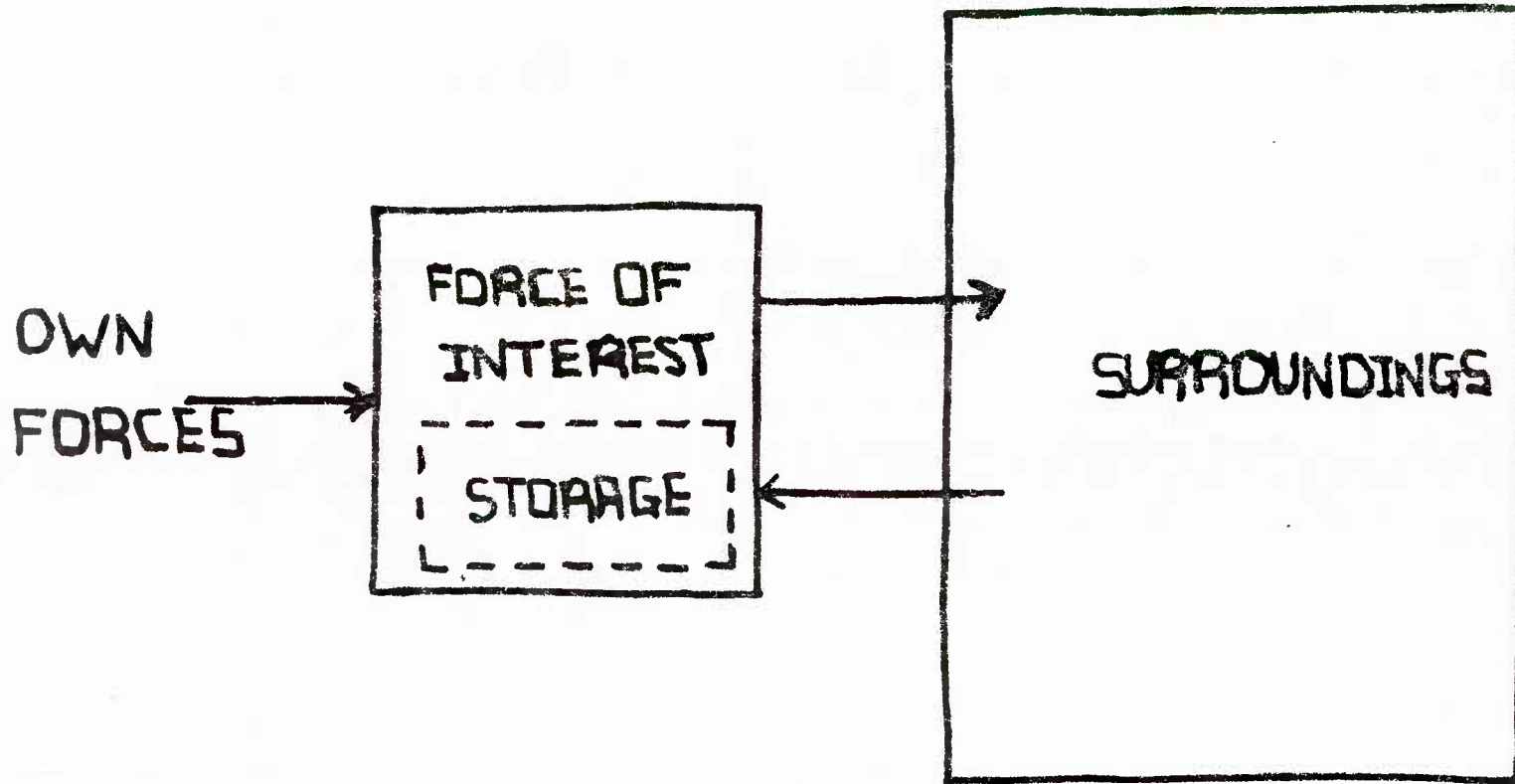

304



ENERGY FLUXES

ENERGY MODEL

2 COMPONENTS OF SURROUNDINGS

(1) ENVIRONMENT

(2) ENEMY FORCES

INTERACTING FORCES ENERGY BALANCE

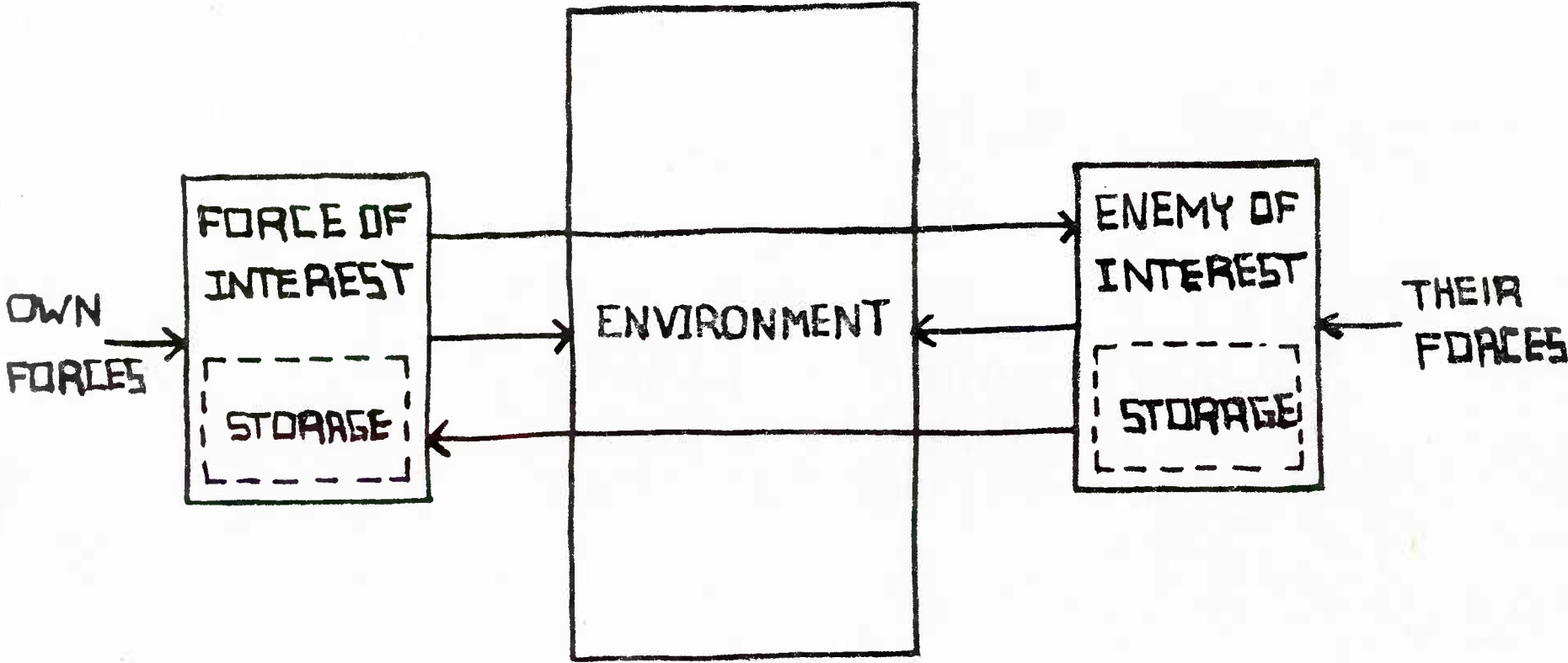

306

→
ENERGY FLUXES

ENERGY MODEL

2 DOMAINS OF ENERGY EXCHANGE BETWEEN FORCES

(1) DESTRUCTIVE (E.G., WEAPONS)

(2) INFORMATIVE (I.E., NONDESTRUCTIVE EMISSIONS)

ENERGY MODEL

INTERFORCE ENERGY FLUXES

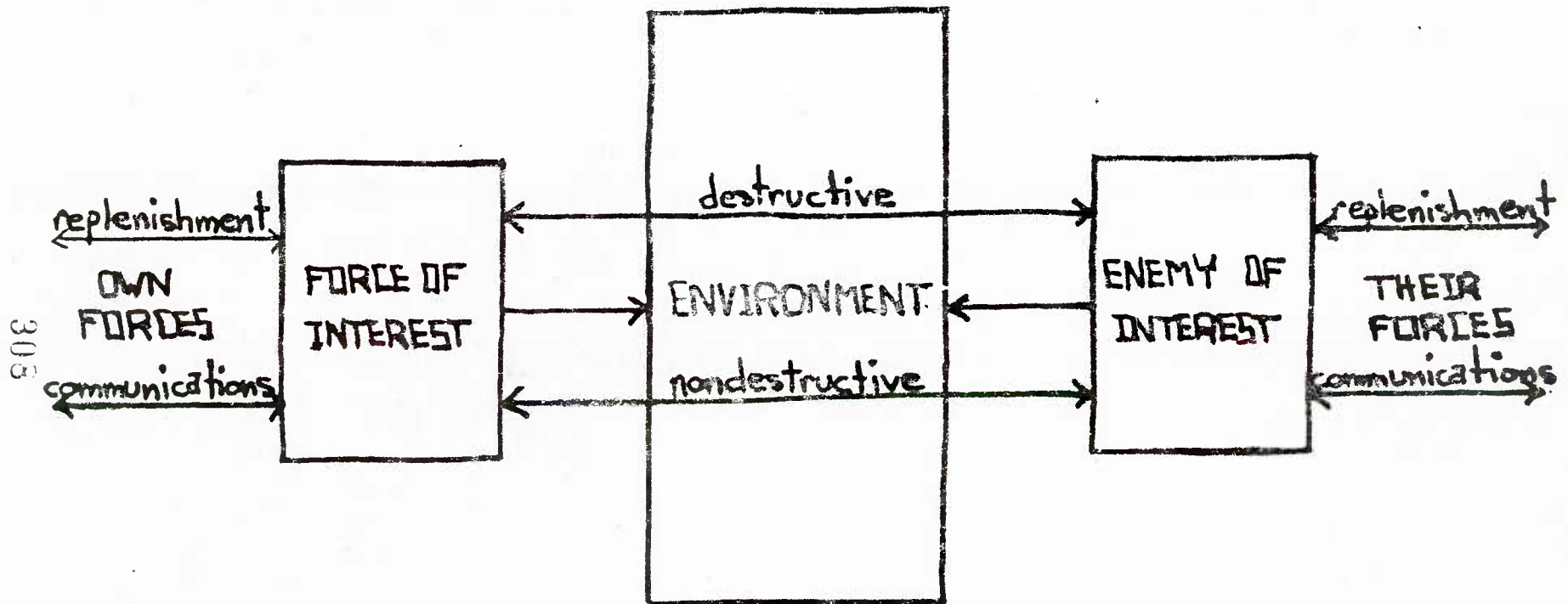

303

→
ENERGY FLUXES

ENERGY MODEL

4 TYPES OF FORCE CAPABILITIES

- (1) SENSORS
- (2) WEAPONS
- (3) COMMUNICATIONS
- (4) SUPPORT

ENERGY MODEL

PARAMETERS DESCRIBING FORCE CAPABILITIES

- (1) RESOURCES (CAPABILITY TYPE)
- (2) SPATIAL VARIABLES
- (3) TEMPORAL VARIABLES
- (4) ENVIRONMENT COUPLING
- (5) ENEMY COUPLING
- (6) SUPPORT COUPLING

ENERGY MODEL

C2 GOALS

- (1) MAXIMIZE WEAPON CHANNELS TO OPPOSING FORCES
- (2) MINIMIZE WEAPON CHANNELS FROM OPPOSING FORCES
- (3) MINIMIZE ND EMISSIONS CHANNELS TO OPPOSING FORCES
- (4) MAXIMIZE ND EMISSIONS CHANNELS FROM OPPOSING FORCES
- (5) MAXIMIZE REPLENISHMENT CHANNELS BETWEEN OWN FORCES
- (6) MINIMIZE REPLENISHMENT CHANNELS BETWEEN OPPOSING FORCES
- (7) MAXIMIZE COMMUNICATIONS CHANNELS BETWEEN OWN FORCES
- (8) MINIMIZE COMMUNICATIONS CHANNELS BETWEEN OPPOSING FORCES

ENERGY MODEL

MAJOR FORCE SUBSYSTEMS

- (1) WEAPONS
- (2) SENSORS
- (3) COMMUNICATIONS
- (4) REPLENISHMENT STORAGE
- (5) CONSUMPTION PROCESSING
- (6) DATA STORAGE
- (7) DATA PROCESSING
- (8) RESTORATION

DATA FLOW MODEL

4 COMPONENTS OF C3 NETWORK MODEL

3 TYPES OF NODES

- (1) SENSOR NODES
- (2) EFFECTOR NODES
- (3) DECISION NODES

1 TYPE OF LINK

- (4) COMMUNICATIONS LINKS

DATA FLOW MODEL

NETWORK MODEL OF C³ PROCESSES

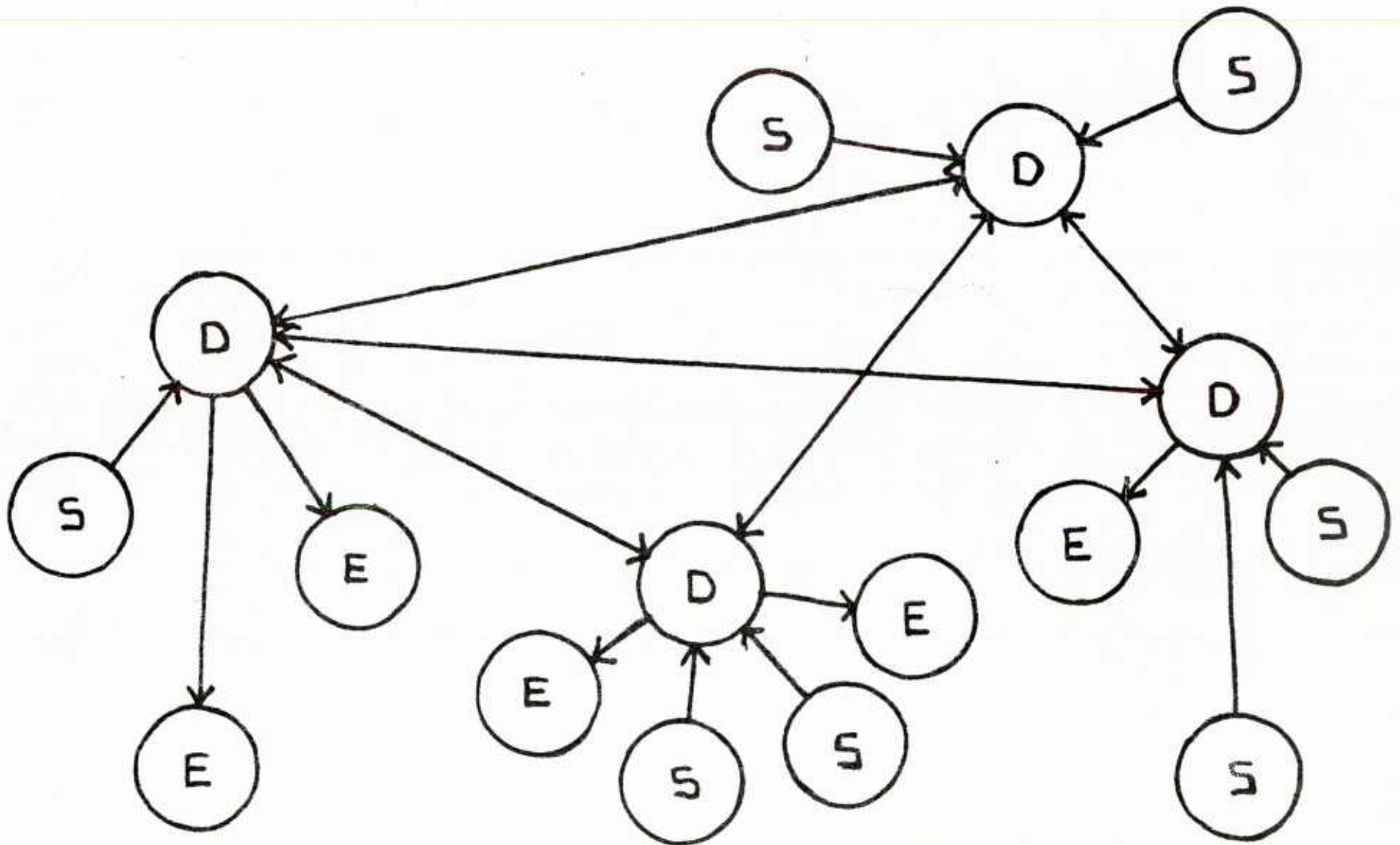

DATA FLOW MODEL

2 DATA FLOW PROCESS TYPES

(1) CONSERVATIVE

(2) NONCONSERVATIVE

DATA FLOW MODEL

NODES REPRESENT NONCONSERVATIVE PROCESSES
LINKS REPRESENT CONSERVATIVE PROCESSES

DATA FLOW MODEL

3 NONCONSERVATIVE PROCESS TYPES

(1) SOURCES (DATA GENERATION)

(2) SINKS (DATA RECEIPT)

(3) TRANSFORMS (DATA CONVERSION)

DATA FLOW MODEL

NODE CHARACTERISTICS

SENSORS & EFFECTORS

- (1) CAPACITY
- (2) INFORMATION COMPONENTS

DECISION

- (1) CAPACITY
- (2) TIME DELAY

LINK CHARACTERISTICS

- (1) CAPACITY
- (2) TIME DELAY

DATA FLOW MODEL
CANONICAL C³ MODEL

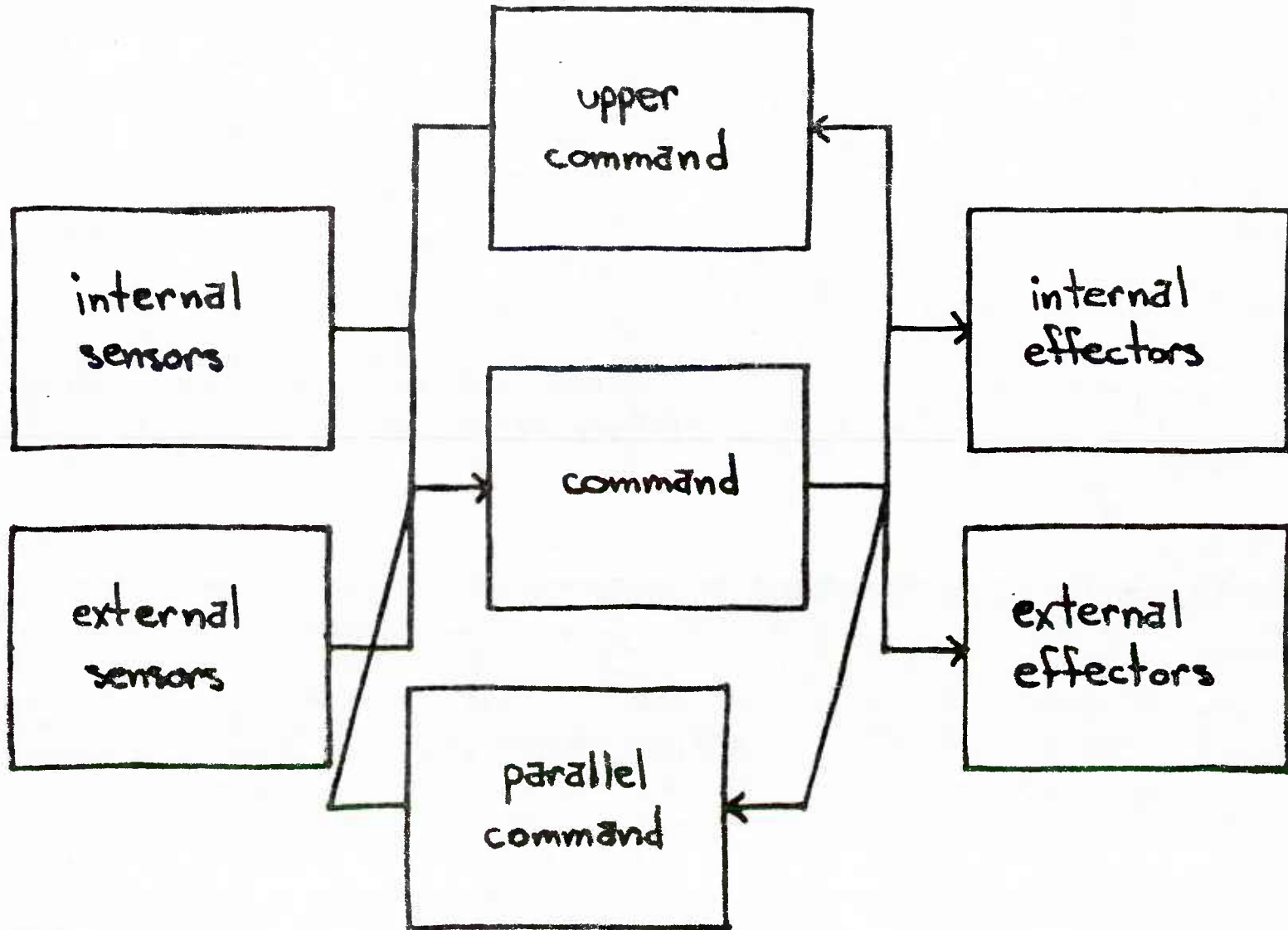

DATA FLOW MODEL

MESSAGE CONTENT TYPES

- (1) ENEMY STATUS INFORMATION
- (2) SELF STATUS INFORMATION
- (3) QUERIES (INFORMATION REQUESTS)
- (4) ACKNOWLEDGEMENTS

DATA FLOW MODEL

MESSAGE CHARACTERISTICS

- (1) MESSAGE LENGTH OR DENSITY
- (2) ACCURACY (RELIABILITY)
- (3) NOISE
- (4) COMPLETENESS

DATA FLOW MODEL

INFORMATION REQUIRED BY A COMMANDER

ENEMY STATUS

- (1) POSITION
- (2) CAPABILITIES
- (3) INTENTIONS

SELF STATUS

- (4) POSITION
- (5) CAPABILITIES
- (6) INTENTIONS

DATA FLOW MODEL

SECURITY IS APPROACHED BY:

- (1) PARTITIONING DATA CHANNELS
- (2) REGULATING DATA FLOW DIRECTION ACROSS PARTITIONS

DATA FLOW MODEL

DECISION NODE PROCESS MODEL

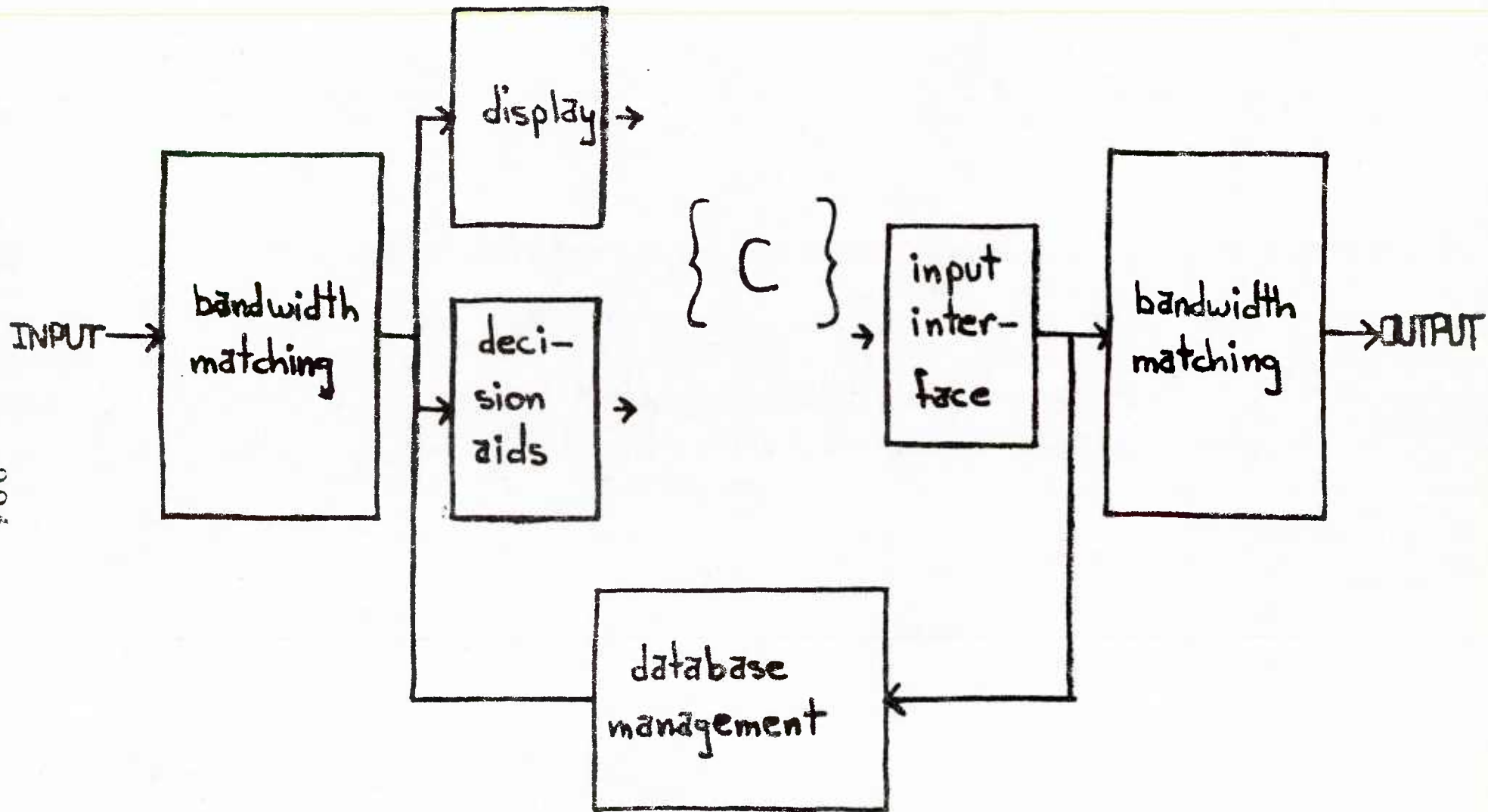

TECHNOLOGY ASSESSMENT METHODOLOGY

2 LEVELS OF APPROACH

- (1) FIRST ORDER TECHNOLOGY ASSESSMENT
- (2) SECOND ORDER TECHNOLOGY ASSESSMENT

TECHNOLOGY ASSESSMENT METHODOLOGY

FIRST ORDER TECHNOLOGY ASSESSMENT -
EMERGING TECHNOLOGY IS EVALUATED ONLY
IN TERMS OF GAINS IN CAPABILITIES PROVIDED.

TECHNOLOGY ASSESSMENT METHODOLOGY

RESPONSE TIMES FOR INTERACTING FORCES

FORCE A

$$t_a = \sum_{i=1}^m \Delta t_i$$

FORCE B

$$t_b = \sum_{j=1}^n \Delta t_j$$

TECHNOLOGY ASSESSMENT METHODOLOGY

RESPONSE TIME COMPARISON

DESIRABLE SITUATION FOR A

$$t_A \ll t_B$$

UNDESIRABLE SITUATION FOR A

$$t_A \gg t_B$$

TECHNOLOGY ASSESSMENT METHODOLOGY

CAPABILITIES PROVIDED BY AN EMERGING TECHNOLOGY CAN
BE COMPARED WITH:

- (1) EXISTING CAPABILITIES (BASELINE)
- (2) CAPABILITIES SUGGESTED BY OTHER EMERGING
TECHNOLOGIES

TECHNOLOGY ASSESSMENT METHODOLOGY

FIRST ORDER TECHNOLOGY ASSESSMENT ASSUMPTION

ALL INTERACTIONS WITH OTHER COMPONENTS OF THE FORCE
HAVE NEGLIGIBLE INFLUENCE ON THE VALUE OF THE
TECHNOLOGY

TECHNOLOGY ASSESSMENT METHODOLOGY

SECOND ORDER TECHNOLOGY ASSESSMENT - CONCEPTS FROM
THE ENERGY MODEL ARE APPLIED TO DERIVE AND EVALUATE
THE INTERACTIONS BETWEEN THE CANDIDATE TECHNOLOGY
AND THE FORCE

TECHNOLOGY ASSESSMENT METHODOLOGY

3 STEPS OF THE TECHNOLOGY ASSESSMENT PROCESS

- (1) DATA FLOW ANALYSIS (1ST ORDER TECHNOLOGY ASSESSMENT)
- (2) FORCE COMPONENT INTERACTION ANALYSIS (2ND ORDER TECHNOLOGY ASSESSMENT)
- (3) MATURITY RATE EVALUATION

TECHNOLOGY ASSESSMENT METHODOLOGY

ANOTHER TECHNOLOGY ASSESSMENT QUESTION

WHEN WILL THE TECHNOLOGY BE AVAILABLE FOR
OPERATIONAL APPLICATION?

TECHNOLOGY ASSESSMENT METHODOLOGY

SUMMARY OF APPROACH FEATURES

- (1) MISSION INDEPENDENT
- (2) PERSONALITY INDEPENDENT
- (3) REFLECTS NO ASPECTS OF DECISION OR ACTION APPROPRIATENESS DIRECTLY
- (4) CAPABILITY ANALYSIS EMPHASIZED
- (5) ALL PARAMETERS CLOSELY RELATED TO MEASURABLE QUANTITIES
- (6) MODELS FOUNDED UPON AND TRACEABLE TO FIRST PRINCIPLES OF PHYSICS
- (7) MODEL CAN BE DRIVEN BY
 - A. TECHNOLOGY FOR COMPARISON
 - B. REQUIREMENTS FOR TECHNOLOGY

CONCLUSIONS

- INFORMATION OF EMERGING TECHNOLOGY FOR NAVY
C³ R&D MANAGEMENT
- TWO PERSPECTIVES PROVIDED
 - A. BROAD & DIFFUSE
 - B. IN-DEPTH & NARROW
- ASSESSMENTS INTERPRETED THROUGH APPLICATION OF
THERMODYNAMICS

A METHODOLOGY FOR APPRAISING THE COMBAT EFFECTIVENESS OF
THE NAVY COMMAND AND CONTROL SYSTEM

George Harris
Code 34T
Fleet Command Center Representative
c/o CINCPACFLT Staff
Pearl Harbor, Hawaii
(808) 471-8636

A METHODOLOGY FOR APPRAISING THE
COMBAT EFFECTIVENESS OF THE NAVY
COMMAND AND CONTROL SYSTEM

by

George Harris

20 July 1979

TABLE OF CONTENTS

	<u>Page</u>
Table Of Contents	ii
List Of Figures	iii
Glossary Of Terms	iv
Abstract	v
Section 1 Introduction	1-1
Section 2 Background	2-1
Section 3 Analysis Methodology	3-1
Section 4 Application	4-1
Section 5 Operational Priorities	5-1
Section 6 Conclusion	6-1
Annex 1 Composite Time Estimates Determined	A-1
By Exponential Smoothing And Linear Regressions	
Annex 2 Learning Effect	A-2
Annex 3 Goal Programming	A-3
Bibliography	7-1

LIST OF FIGURES

<u>Figure</u>		<u>Page</u>
1	NCCS And WWMCCS Network Configuration	2-2
2	Targeting Steps	3-1
3	MOE Time Description Summary	3-3
4	Methodology Overview	3-6
5	Sample Calculation For The Time Imbalance In Event XXX	3-8
6	Value Of FCC And TFCC Events To Survival Of Afloat Units	4-2
7	Estimated Hours Of Survival Time Achieved As A Result Of Exercise Iteration	4-4
A1	Composite Time Forecast Estimates	A-1-2
A2	Steps Of Goal Programming Model Formulation	A-3-2
A3	Influence Of OPDEC On Timeliness Imbalance	A-3-4
A4	Goal Programming Model	A-3-5

GLOSSARY OF TERMS

ADP	Automatic Data Processing
C ³ COMEX	Command, Control, and Communications System Commence Exercise
FCC FINEX	Fleet Command Center Finish Exercise
MOE	Measure of Effectiveness
NCCS	Navy Command and Control System
OPDEC	Operational Deception
SOSS	Soviet Ocean Surveillance System
TFCC	Tactical Flag Command Center
WMCCS	Worldwide Military Command and Control System

ABSTRACT

The combat effectiveness of the Navy Command and Control System is evaluated according to its ability to provide timely information to the commanders. The appraisal methodology is designed for use in a computer oriented war game facility. The war game scenarios are theater level. The methodology includes a computer display of the measure of effectiveness and a modes of failure technique for the analyst.

" A lost battle is a battle one thinks one has lost."

Ferdinand Foch, Principes de Guerre

SECTION 1. INTRODUCTION

One of the difficulties in presenting a paper on command and control is that the command system literally touches everything. Everyone, including this author, has their private view of what is really important. A C^2 paper that satisfies everyone, and no one is bored, is unlikely. The best we can do is to be clear about what part of C^2 we are considering.

This paper addresses the combat performance of the Navy Command and Control System (NCCS). The assumption here is that battle is the acid test. If it works in battle it is good. What we need then is a battle model. Along with it we need a model of how to think about the questions we should ask. How do we think about a battle so that we can identify the significant performance variables? How do we separate the variables that belong to the command system from those that belong to weapons?

A battle is dynamic and time sequenced. However, most analyst tend to give you an end result box score. This does not account for the dynamics that caused the results. We need a standard frame of reference from which to view the dynamics. The frame of reference must be constant and apply to a whole series of battles without equivocation.

The targeting sequence is used here as either a means of achieving the operational objective, or of increasing survival while in

pursuit of the operational goal. NCCS is examined as an information system that supports the commander's ability to target the enemy and to deny the enemy the ability to target the commander.

The targeting process is the model for a battle. The targeting model and the C² investigative process are designed primarily for use with a computer oriented war game facility. The entire methodology measured in this paper has in fact been selected for incorporation in the software for the CINCPACFLT War Game Facility. The computer will thus provide a post exercise identification and display of all the targeting failures that occurred during the war game. The analyst will then be relieved of an enormous amount of pick and shovel work. He can proceed directly to the critical events for detailed analysis. The methodology continues through the initial analysis to the application of corrective variables to attain the operational goal.

SECTION 2. BACKGROUND

Analysis of NCCS as a combat system requires consideration of command systems for both the United States Navy and the Soviet Navy. NCCS is shown schematically in Figure 1. At the top of the chain of command, the Worldwide Military Command and Control System (WWMCCS) supports the National Military Command System. NCCS is the United States Navy's system that interfaces with WWMCCS. The functional supporting systems, along with WWMCCS, are worldwide networks. They provide information to each NCCS node in accordance with various interface and/or integration configurations.

The Soviet Navy Command and Control system can be compared with NCCS. The Soviet press has stated, in news media announcements of worldwide OKEAN exercises, that command and control of forward fleet units can be exercised from Moscow. This establishes an essential feature of analysis. Any simulation of the Soviet Navy Command System must include the total hierarchy, from forward fleet units to the highest echelon in Moscow.

Both the Soviet Command, Control, and Communications (C³) System and NCCS have the military functional requirement to support the attainment of target solutions on enemy units. The fact that they have different missions, different weapon systems, and different command philosophies in no way alters the basic and competitive requirement to target the enemy.

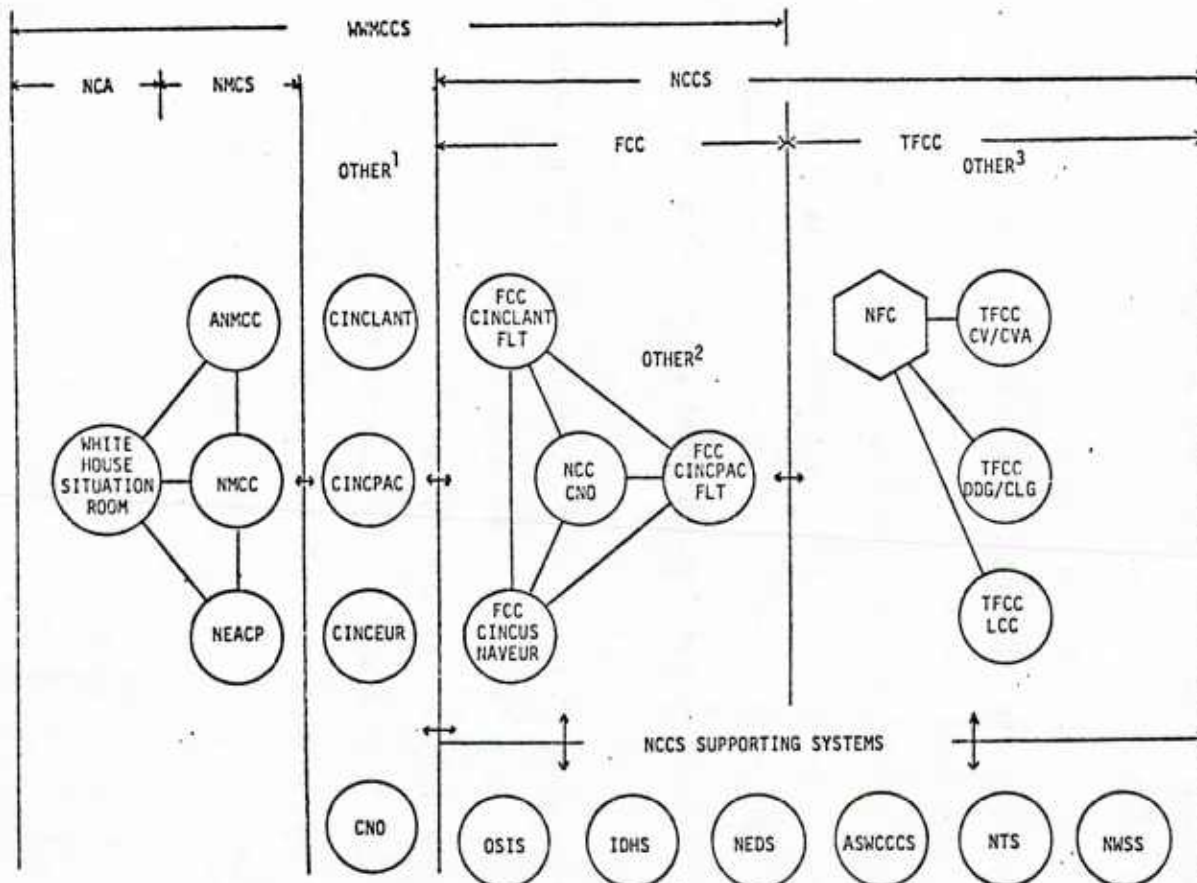

- ANMCC - Alternate National Military Command Center
- ASWCCCS - Antisubmarine Warfare Centers Command and Control System
- CINCEUR - Commander in Chief, Europe
- CINCLANT - Commander in Chief, Atlantic
- CINCLANTFLT - Commander in Chief, U. S. Atlantic Fleet
- CNO - Chief of Naval Operations
- CINCPAC - Commander in Chief, Pacific
- CINCPACFLT - Commander in Chief, U. S. Pacific Fleet
- CINCUSNAVEUR - Commander in Chief, U. S. Naval Forces, Europe
- CV/CVA - Aircraft Carrier/Attack Aircraft Carrier
- DDG/CLG - Guided Missile Destroyer/Guided Missile Light Cruiser
- FCC - Fleet Command Center
- IDHS - Intelligence Data Handling System
- LCC - Amphibious Landing Craft
- NCA - National Command Authority
- NCC - Navy Command Center
- NCCS - Navy Command and Control System
- NEACP - National Emergency Airborne Command Post
- NEDS - Naval Environmental Data System
- NFC - Numbered Fleet Commander
- NMCC - National Military Command Center
- NMCS - National Military Command System
- NTS - Navy Telecommunication System
- NWSS - Navy WWMCCS Standard Software
- OSIS - Ocean Surveillance Information System
- TFCC - Tactical Flag Command Center
- WWMCCS - Worldwide Military Command and Control System

1: CMDS, DEPTS, AGENCIES

2: SUBORDIANTE CMDS

3: NON TFCC UNITS

Figure 1. NCCS And WWMCCS Network Configuration

SECTION 3. ANALYSIS METHODOLOGY

The methodology was designed specifically to aid investigative analysis of the combat effectiveness of NCCS. Computers are used wherever possible to reduce the analysis manpower requirement. Computers collect the data and perform initial rough-cut analyses. The human analysis is then performed to qualify the data and investigate in detail the events identified by the computer analysis.

As pointed out in the assumptions, targeting effectiveness is the most critical single measure by which a combat operation can be judged. Targeting is composed of classic steps that are common to all weapons and any size of engagement. Figure 2 shows the targeting steps plus a factor called "mission survival."

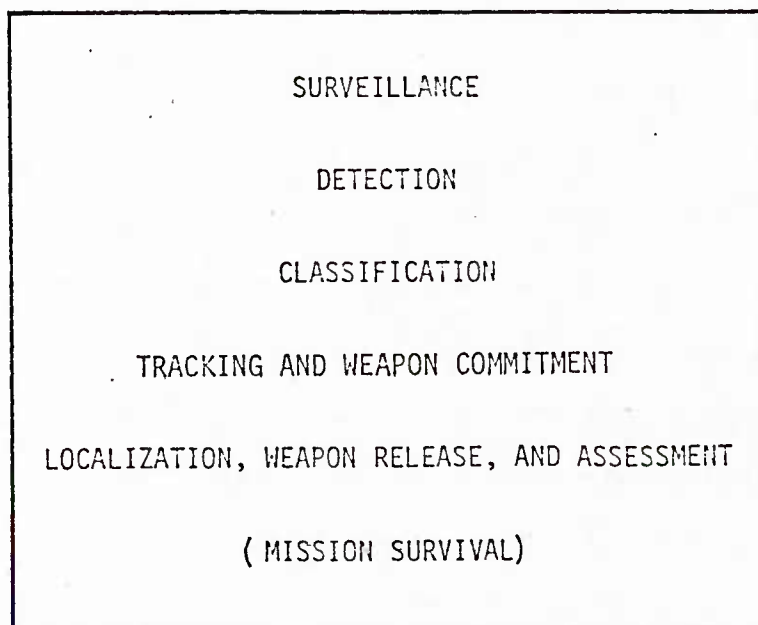

Figure 2. Targeting Steps

The targeting steps are in a critical time path. Each step constrains the following step. The completion of each step is measured in time. "Mission survival" is not a targeting step but it is a function of the steps and is achieved only when the opposing force does not achieve weapon release criteria before own force does.

In other words, mission accomplishment is a function of survival. Some minimum survival time is necessary for the performance of each mission. Force survival might exceed the minimum time and still be billed before the mission is successfully accomplished. Even so, the analysis of the competitive race for targeting will still reveal deficiencies in NCCS functioning as an information system. The relative targeting timeliness advantage that is achieved by one force over the opposing force is used as the basic Measure of Effectiveness (MOE) in this methodology.

Figure 3 shows the appropriate notation given to each force, each targeting step, and the equations to calculate the incremental and the cumulative MOEs. The measure is in scalar units of time over which there can be no confusion or equivocation. The steps themselves are understandable to technicians and operators. The MOE provides a standard frame of reference that supports additional detailed analysis as well as time standards for system operational performance.

The MOE targeting data is accumulated automatically in the MOE data base during the course of the simulation.

It should be noted that the characterization of this MOE belongs to the commander rather than the technician. The commander's success is literally governed by the stark reality of which side can target the

MOE for INCREMENTAL VALUES: $\delta_j = X_j - Y_j$

MOE for CUMULATIVE VALUES: $\Delta_j = \sum_{i=1}^j \delta_i$

TARGETING STEPS	C ³ SYSTEM TIME TO COMPLETE		TIME OF IMBALANCES	
	Threat X_i	Own Force Y_i	INCREMENTAL $\delta_i = X_i - Y_i$	CUMULATIVE $\Delta_j = \sum_{i=1}^j \delta_i$
Detection	X_1	Y_1	$\delta_1 = X_1 - Y_1$	$\Delta_1 = \delta_1$
Classification	X_2	Y_2	$\delta_2 = X_2 - Y_2$	$\Delta_2 = \delta_1 + \delta_2$
Tracking	X_3	Y_3	$\delta_3 = X_3 - Y_3$	$\Delta_3 = \delta_1 + \delta_2 + \delta_3$
Weapon Release	X_4	Y_4	$\delta_4 = X_4 - Y_4$	$\Delta_4 = \delta_1 + \delta_2 + \delta_3 + \delta_4$
Survival	X_5	Y_5	$\delta_5 = X_5 - Y_5$	

Where Threat is X and Own Force is Y

Figure 3. MOE Time Description Summary

other first. Targeting is the essence of combat. The force that can consistently achieve a targeting solution first is generally considered to be the victor. Given any event in which a Red missile impacts Blue unit, the MOE can then be used as an illuminator of where and when the engagement went wrong. It is up to the analyst to identify the thread and trace it to its source. The timeliness imbalance should be seen as the point of perspective from which to examine all weapons and the entire information handling system that caused the imbalance to occur.

The scope of the targeting process used here includes availability and deployment of sensors, processing of sensor input, authorization and commitment of platforms and weapons to a target, and achieving weapon release criteria sufficient to kill the target. Communication capability is considered to be part of each step in the process.

NCCS is appraised on its ability to function as a command information system. Its objective in combat situations is to provide timely information to support the targeting process. Any time the threat completes the process first, the NCCS process is inspected for its reciprocal actions during that event to determine possible modes-of-failure. This provides an opportunity to view the entire ashore and afloat NCCS structure from the analytic standpoint of how well it did or did not support that single tactical event.

Deficiencies related to a specific event can also be noted for weapon and sensor characteristics and operational procedures. The basic purpose of the analysis, however, is to investigate the combat information handling capabilities of NCCS.

Figure 4 shows the methodology overview. The first eight boxes are concerned with generating data by war gaming Blue forces against Red forces in a free play simulation exercise. The exercise can either be an at-sea major fleet exercise or a computer driven war game played with separate decision areas for Blue and Red teams.

The analysis plan in Box 1 contains provisions for all technical and operational requirements. It is based on a specific operational mission or task from higher authority. A Letter of Instruction goes to Red and Blue for use in preparing operational plans. Each commander estimates the minimum survival time required for his forces in order to accomplish the task. This estimated survival time will be used in the post exercise analysis. It can also be used as a basis for establishing standards of timeliness performance for NCCS. The forces technical weapon and sensor characteristics, including the respective C³ configurations, are in Automatic Data Processing (ADP) files.

The war game in Box 8 is played by Blue and Red teams.

The Soviet Ocean Surveillance System (SOSS) time estimates in Box 6 are based upon observed real world performance times combined with estimates from qualified observers. One suggested quantitative technique for doing this is to combine exponential smoothing with linear regression. Details of this process are shown in Annex 1.

The analysis function in Box 9 is supported by the computer-oriented time imbalance MOE in Box 10 and the manually oriented modes-of-failure analysis in Box 11.

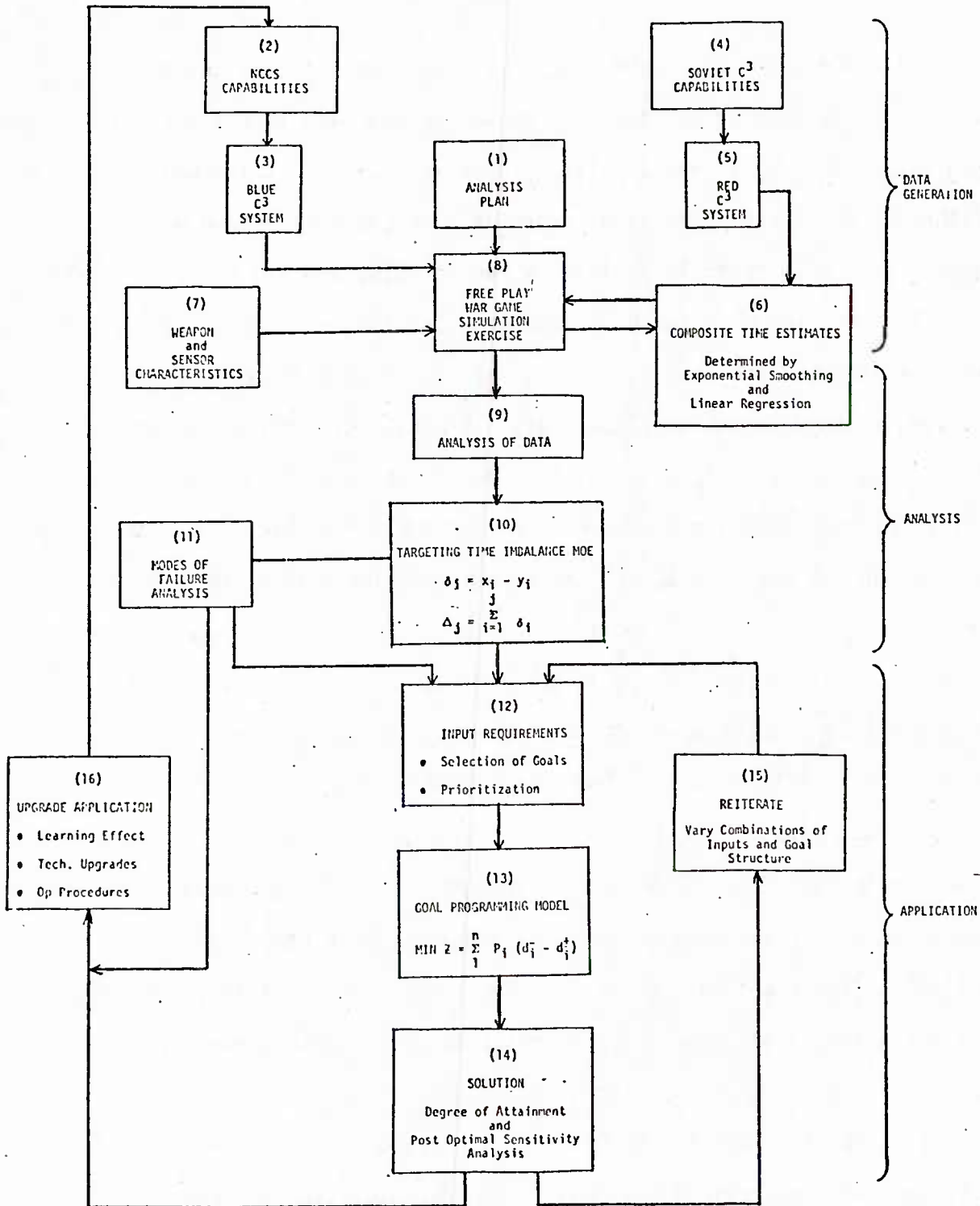

Figure 4. Methodology Overview

The MOE in Box 10 is based on the targeting steps described above. Mission survival time increases as the time required to complete the targeting process decreases relative to the threats time. The following equation is postulated:

$$T_s = \frac{1}{T_t}$$

where T_s = mission survival time

and T_t = targeting time relative to enemy targeting time

A sample of time calculation is shown in Figure 5. Assume, for example, that surveillance commenced for both sides at the same time. Detection occurs at 20 hours for Red and one-hour later for Blue. Blue classified faster than Red, but the -.54 hour cumulative time still favors Red. Red achieves weapon release and kills Blue while Blue is still in the tracking step. The 23.95 hour Blue survival time, in this case, is defined by the sum of the Red time to target.

The time imbalance MOE indicates a mode-of-failure for this event in the detection step. Manual analysis is then conducted to determine:

- a. How much of the -.54 hour time imbalance is due to an identifiable NCCS deficiency? Could NCCS reduce its processing time by -.54 hour?
- b. What information in the hands of the commander would have prevented the imbalance? What timeliness factor could have been achieved? What available assets could have been used?
- c. How much of the time imbalance is due to an identifiable operational procedure?
- d. What resource, external to NCCS, could account for the -.54 hour imbalance?
- e. What are all the significant related tactical imbalances that can be identified with this event, e.g., temporal, spatial, weapon, and sensor?

TARGETING STEPS	C ³ SYSTEM TIME TO COMPLETE		TIME OF IMBALANCES**	
	RED X _i (HOURS)	BLUE Y _i (HOURS)	INCREMENTAL $\delta_i = X_i - Y_i$ (HOURS)	CUMULATIVE $\Delta_j = \sum_{i=1}^j \delta_i$ (HOURS)
	DETECTION	20.0	21.0	-1=20-21
CLASSIFICATION	0.25	0.19	+0.06=.25-.19	-.54= -1+.06
TRACKING	3.5	Blue tracking was interrupted		
WEAPON RELEASE	0.2	Blue weapon release was not attempted		
SURVIVAL	Yes	23.95*		

* Blue survival is the sum of Red targeting time.

** A negative sign in the solution favors Red.
A positive sign favors Blue.

Figure 5. Sample Calculation
For The Time Imbalance In Event XXX

SECTION 4. APPLICATION

Depending on the analysis objectives set forth in the Analysis Plan, the results of the analysis can be applied in many ways. One of the most interesting is the area of support provided by the Fleet Command Center (FCC) ashore to the Tactical Flag Command Center (TFCC) afloat.

Figure 6 shows a time history of theoretical value curves for ashore and afloat events. The time line represents time and/or distance that separates the opposing Red and Blue forces. Commence Exercise (COMEX) occurs at time zero when the Red force deploys out of area and closes to attack Blue force. Finish Exercise (FINEX) occurs when a Red missile could impact its Blue target. The value axis represents Blue force survival time that is achieved by the sequence of events taken by the FCC and TFCC. The TFCC afloat line represents the survival value of the sequential targeting steps; i.e., surveillance, detection, classification, tracking, and weapon release. Each step has a greater value as the time of potential impact draws near.

Although the FCC ashore line has not yet had its sequence of events documented, the theory is advanced here that the earlier steps will have the greatest value. As the time approaches when the Red force crosses into the Blue area of tactical responsibility, the value of ashore events becomes less and the value of the TFCC afloat events becomes greater. The intersection occurs when Red force crosses into the area of tactical responsibility, the value of ashore events becomes less and the value of the TFCC afloat events becomes greater. The

355

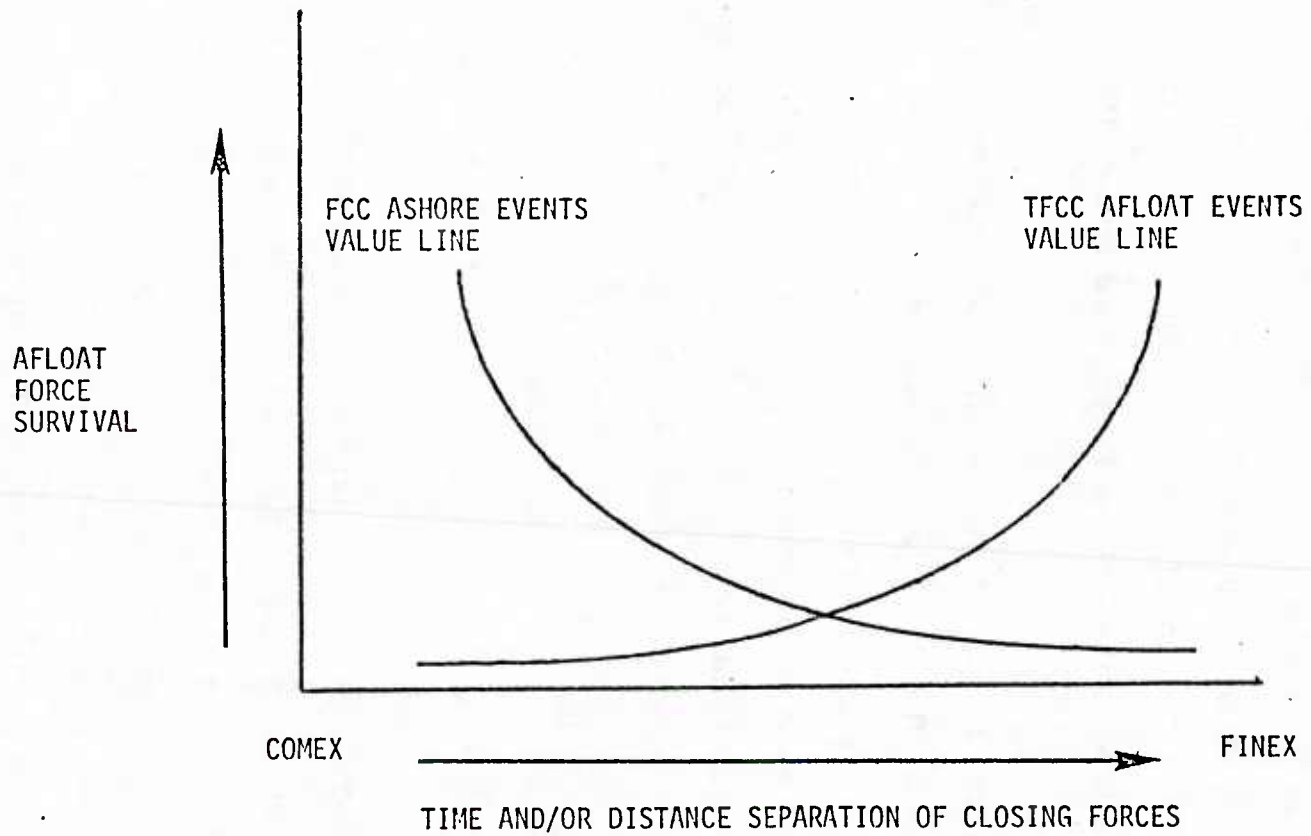

Figure 6. Value Of FCC And TFCC Events To Survival Of Afloat Units

intersection occurs when Red force crosses into the area of tactical responsibility of Blue force.

It is suggested that during periods of high emission control, when the TFCC must remain silent, the FCC can direct large ocean area cover and deception operations. This will have the effect of degrading the enemy targeting process. The end result will be a targeting timeliness advantage that favors own forces.

The result of each full simulation/exercise of a given mission will tend to be an increase in Blue survival time. This is based on an optimization factor that has been demonstrated in many technical and operational situations. It is called the "learning effect." (Annex 2.)

Briefly, it says that learning time is transient. For example, every time an attempt is made to target the enemy, the process will take less time than before. When targeting time is reduced, survival time goes up. Figure 7 shows that survival time increases up to a point as a function of the number of exercises devoted to a particular task. The operational rationale for the curve is as expressed earlier in the paper, namely that mission survival is inversely proportional to the relative timeliness advantage that is achieved in the targeting sequence. The MOE shown in Figure 3 develops the relative targeting timeliness.

The interesting thing about the learning curve is that it can be achieved by slowing the enemy C³ process down as well as by making NCCS process work faster. There are many operational situations in which slowing the threat down will be the only feasible alternative.

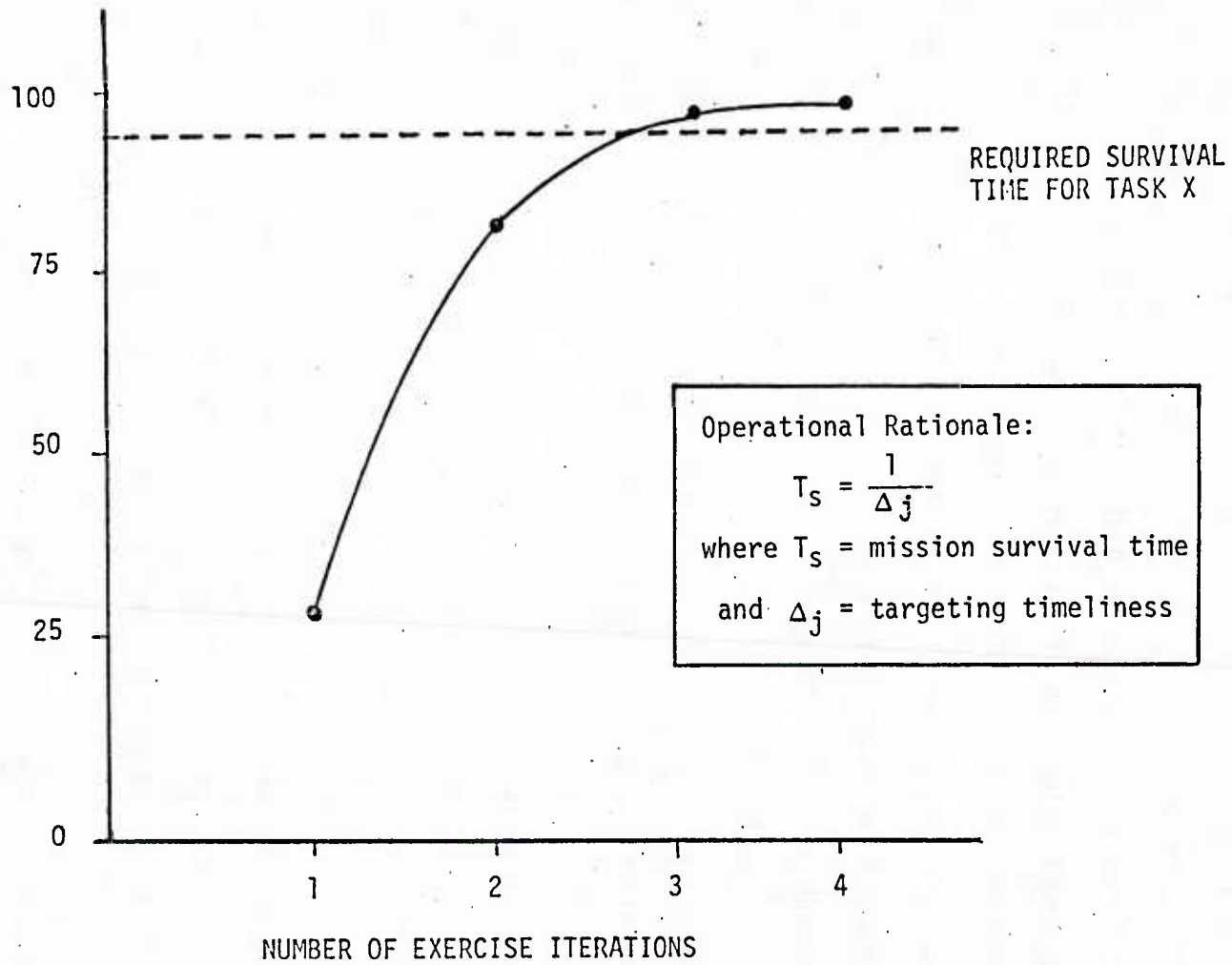

Figure 7. Estimated Hours Of Survival Time Achieved As A Result Of Exercise Iteration

SECTION 5. OPERATIONAL PRIORITIES

In a major operation there will be a problem in assigning priorities for the various timeliness goals. A method is needed to work with the goals, priorities, and resources. Goal programming is introduced here as a means of working with these timeliness factors.

Goal programming is used to illustrate the premise that linear mathematics can serve as our first approximation of real world C^3 problems. Goal programming is an extension of linear programming. Whereas linear programming deals with the attainment of a single goal by either maximization or minimization of the objective function, goal programming deals with the attainment of multiple goals by minimizing the underachievement or overachievement of goal constraints. Annex 3 contains a short tutorial on goal programming as well as an operational scenario in which a problem in timeliness priorities is formulated in goal programming equations.

SECTION 6. CONCLUSION

The following results, conclusions, and implications are made:

a. Results

(1) NCCS is described as an information system that supports ashore and afloat commanders in a warfare environment.

(2) An appraisal methodology is described.

b. Conclusions

(1) The appraisal methodology will identify vulnerabilities in NCCS as well as other significant elements of the targeting process, e.g., sensors, interceptors, and weapons.

(2) Targeting time, relative to the threat targeting time, can be reduced thus increasing survival time of own forces.

(3) Requirements for technology, operational procedures, and operational plans can be documented.

c. Implications

(1) War gaming will continue to be basically an exploratory device, but will tend to become connected with training functions.

(2) The appraisal process and its maturing will reveal many opportunities for management and organizational changes to accommodate advances in technology, and changes in warfare.

(3) The appraisal process will encourage experimentation with joint and combined operations.

ANNEX 1

COMPOSITE TIME ESTIMATES
DETERMINED BY EXPONENTIAL
SMOOTHING AND LINEAR REGRESSIONS

ESTIMATING RED C³ SYSTEM RESPONSE TIMES

The collective opinion of qualified analysts is a common and tractable form of making such estimates. The subjective belief of an intelligence analyst is as good as, or better than, what can be achieved by a more sophisticated quantitative approach.

A technique moving beyond the collective opinion approach uses a composite estimates mode which combines real world data with subjective estimates. The composite technique is shown graphically in Figure A1. First, an estimate is based on observed data alone. Subjective estimates are then made in the form of "expected," "high," and "low" values for each of four time periods. A linear regression analysis basically serves to average out the four points for each of the time periods. The composite forecast is thus based on exponential smoothing to analyze the past data and on subjective estimates to analyze the future.

The high, expected, and low estimates represent a range in values in the mind of the estimator. Exponential smoothing is a method of exponentially weighted moving averages. The basic formula is:

$$F_{i+1} = F_i + \alpha (D_i - F_i)$$

where F_i is the forecast for the i th period,

D_i is the demand (value of the variable) for the i th period

is a value such that $0 < \alpha < 1$.

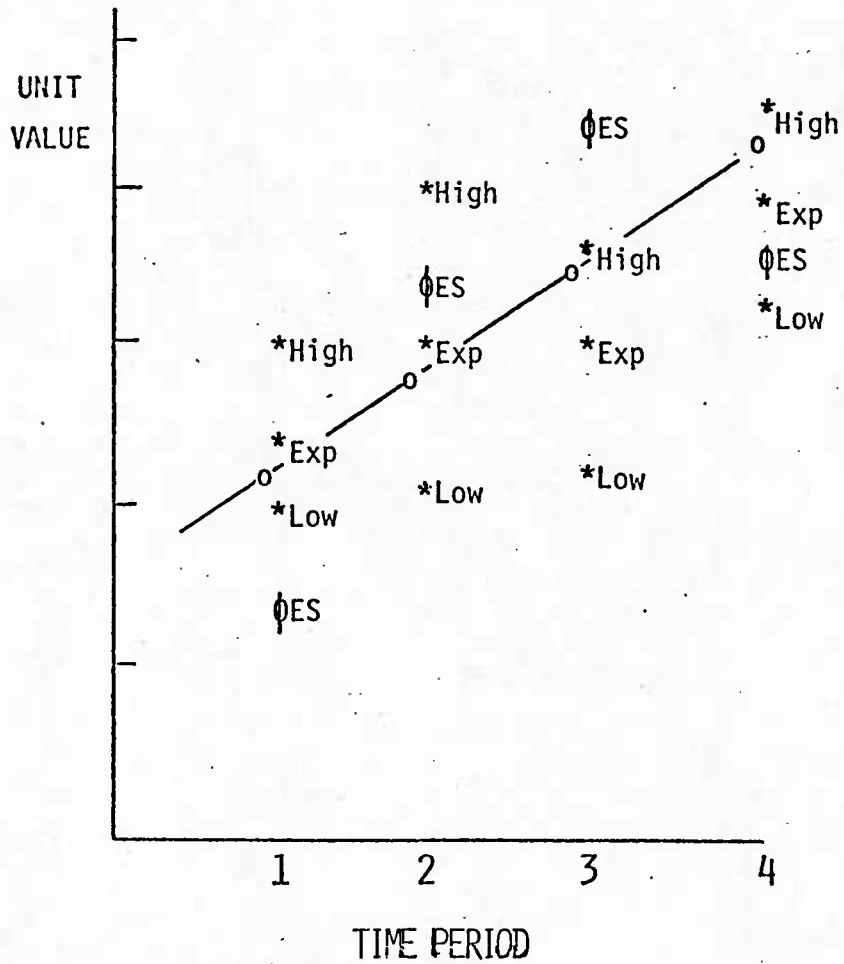

*Subjective estimates
 φ = Forecast provided by exponential smoothing.
 0 = Composite forecast value generated by regression analysis.

Figure A1. Composite Time Forecast Estimates

ANNEX 2

LEARNING EFFECT

PREDICTION OF OPERATOR PERFORMANCE DURING LEARNING OF REPETITIVE TASKS

- F. W. BEVIS,* C. FINNIEAR† AND D. R. TOWILL*

SUMMARY

Learning effects in the execution of repetitive tasks may often be adequately described by an exponential law commonly found in physical systems. This law is characterised by the rise time and the final value of output rate. An iterative method is developed for the determination of rise time and final value using only performance data recorded during early stages of learning, and is shown to predict these parameters sufficiently accurately for use in costing and in continuously updating time standards. Further uses of the predictive technique include highlighting the need for increased supervision, or the replacement of particular operatives.

When experimental data is oscillatory in nature, prediction errors are greatly reduced by three-point averaging tuned to the period of oscillation. Much of the experimental data has been recorded in industrial environments, frequently for long production runs.

INTRODUCTION

It has long been recognised that output per unit time is a continuously increasing quantity in many different industrial engineering tasks; the phenomenon is usually known as learning. Long (1957) has shown that learning data obtained in a wide range of production operations may be curve fitted by extending the composite mathematical model used in aircraft production (Wright, 1936). More recently, Bevis (1970) has reviewed 30 contributions related to learning phenomena and learning data curve fitting.

These papers are devoted either to understanding the factors affecting the mechanism of learning, or curve fitting in historical fashion over the full production run. In contrast this paper is concerned with predicting ultimate performance and the time scale in which it is approached. Furthermore, it is considered that there is a fundamental need for a predictive technique which will reliably estimate learning parameters from data recorded during the early part of the production run. Such parameters may then be used for: (a) costing purposes, (b) recognising the transient nature of time standards, (c) highlighting individual operator inadequacy, (d) indicating need for supervisory action.

Learning data may be presented in three different forms, as shown in Fig. 1. It is the output rate versus time form of Fig. 1 which is used in this paper.

*Industrial Engineering Unit, University of Wales Institute of Science and Technology, Cardiff CF1 3NU, Wales. (Mr. F. W. Bevis is now with the Management Services Training Section, Strip Mills Division, British Steel Corporation, Port Talbot, Glamorgan.)

†H.M. Inspectorate of Factories, Cardiff, Wales.

Received by Int. Jnl. Prod. Research, November 14, 1969.

The International Journal of Production Research (1970), Volume 8, No. 4.
Published by *The Institution of Production Engineers*, 10, Chesterfield Street, London, W.1, England.

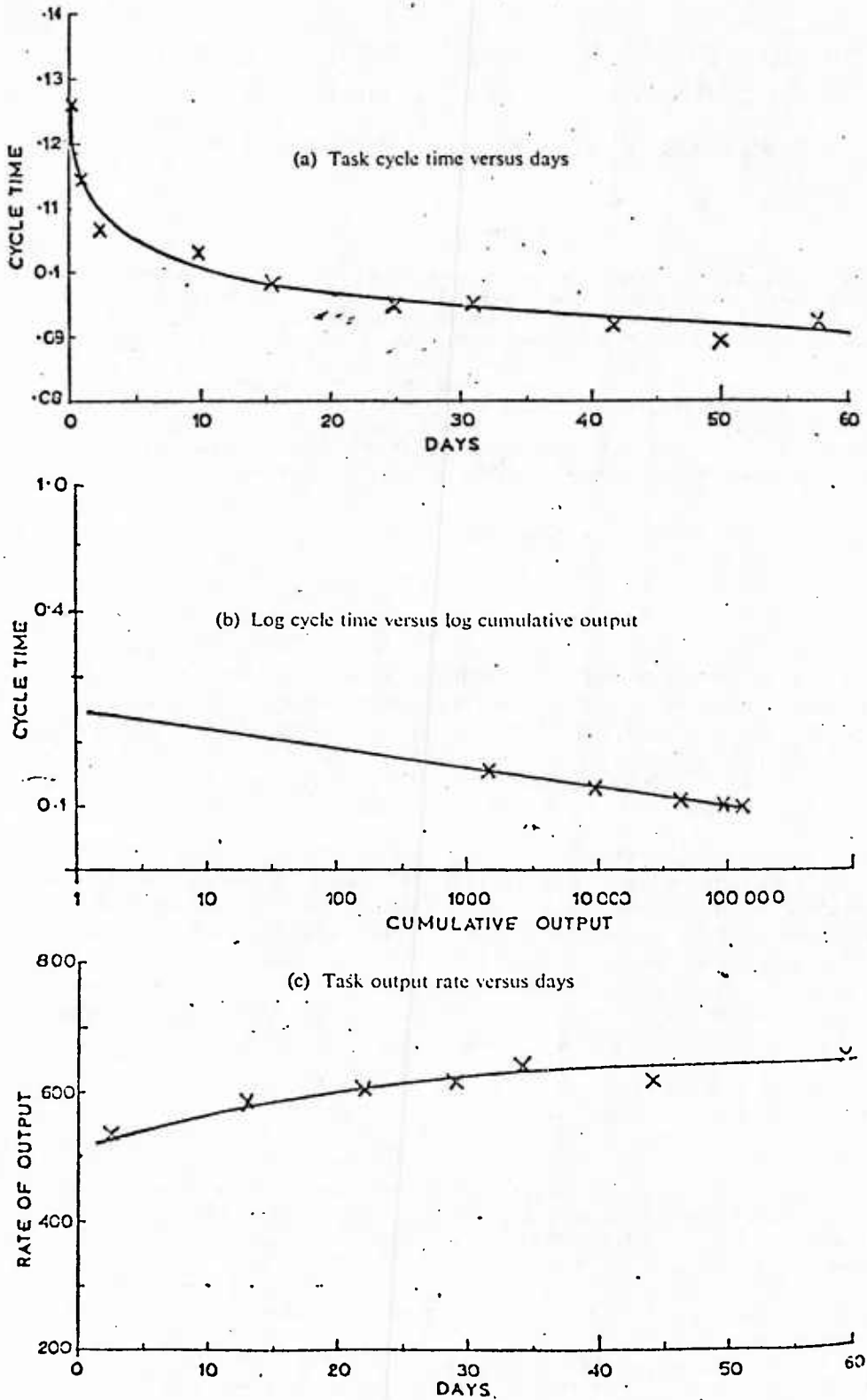

Fig. 1. Three alternative forms of presenting learning curve data

PREDICTION OF LEARNING IN REPETITIVE TASKS

EXPONENTIAL FORM OF OPERATOR OUTPUT

Bevis (1969) has analysed a variety of learning studies, and has shown that when plotted in the form of Fig. 1(c), the transient part of the output rate may be adequately described by the law

$$Y = Y_f(1 - e^{-t/\tau}) \quad (1)$$

The initial output rate is known and is therefore accounted for. A physical system with the same control law is shown in Fig. 2 (Shearer, Murphy & Richardson, 1967), and the law is well understood. For example, the transient part defined by equation (1) reaches 63 per cent of final value at time $t = \tau$, and reaches 95 per cent of final value at time $t = 3\tau$. τ is known as the rise time, or "time constant".

CURVE FITTING ERRORS

If N data points are available, the transient part of output rate is represented by the series Y_1, \dots, Y_N . At each data point the corresponding estimated series using a particular control law is given by $\bar{Y}_1, \dots, \bar{Y}_N$. The total error squared is then

$$E^2 = \sum_1^N E_i^2 = \sum_1^N (Y_i - \bar{Y}_i)^2 \quad (2)$$

To seek the values of Y_f and τ which minimise equation (2): the customary least squares minimisation analysis becomes unwieldy due to the non-linear nature of the subsequent equations and must be solved using hill-climbing techniques. A better solution for the data recorded to date is the utilisation of the Taylor series expansion in an iterative loop, the resulting equations are then linear and easily solved.

TAYLOR SERIES EXPANSION OF THE EXPONENTIAL CONTROL LAW

Replacing $1/\tau$ in equation (1) by Z , to simplify subsequent manipulation, the estimated value of Y at time t_i may be written as follows:

$$\bar{Y}_i = f(Y_f, t_i, Z) \quad (3)$$

Expanding equation (3) about the estimated value of \bar{Y}_i , using current best estimates of Y_f and Z (\bar{Y}_f and \bar{Z} respectively), terms above first order being ignored, yields:

$$\bar{Y}_i \approx f(\bar{Y}_f, t_i, \bar{Z}) + \frac{\partial f}{\partial Z} \Delta Z + \frac{\partial f}{\partial Y_f} \Delta Y_f \quad (4)$$

where

$$\frac{\partial f}{\partial Z} = t_i \cdot \bar{Y}_f \cdot e^{-t_i \bar{Z}} \quad (5)$$

$$\frac{\partial f}{\partial Y_f} = 1 - e^{-t_i \bar{Z}} \quad (6)$$

Substituting equations (5) and (6) into (4), the estimate becomes

$$\bar{Y}_{ir} \approx [\bar{Y}_{fr}(1 - e^{-t_i \bar{Z}_r})] + [t_i \bar{Y}_{fr} e^{-t_i \bar{Z}_r}] \Delta Z + [1 - e^{-t_i \bar{Z}_r}] \Delta Y_f \quad (7)$$

where the suffix r signifies the r th estimate.

After Q iterative loops adequate estimates of \bar{Y}_f and \bar{Z} are obtained, and since ΔY_f and ΔZ are negligible, equation (7) reduces to

$$\bar{Y}_{iQ} \approx \bar{Y}_{fQ}(1 - e^{-t_i \bar{Z}_Q}) \quad (8)$$

and prediction is then complete.

A Taylor series approach is herein proposed to predict best estimates in the least squares error sense. For an input of a given number of data points the predictive technique iterates until the increments sought in rise time and final value are both less than some chosen value. Where the data forms an oscillatory time series, the predictions are suitably smoothed, and this is shown to result in great increase in accuracy.

(For nomenclature, see page 302.)

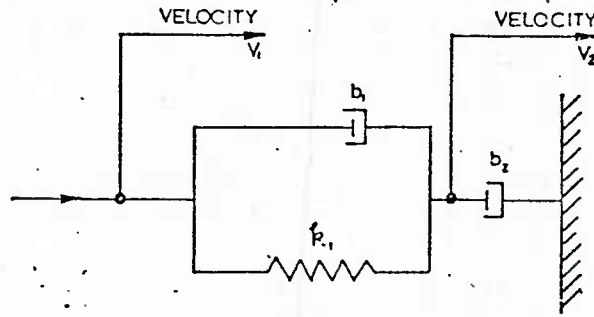

(a) Simple spring dashpot system

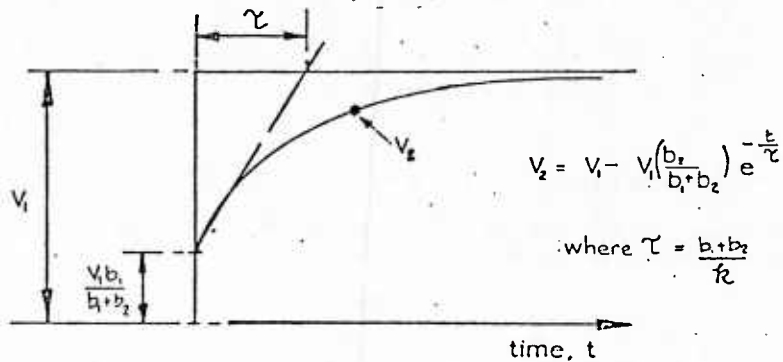

(b) Response of simple spring dashpot system to step change in V_1

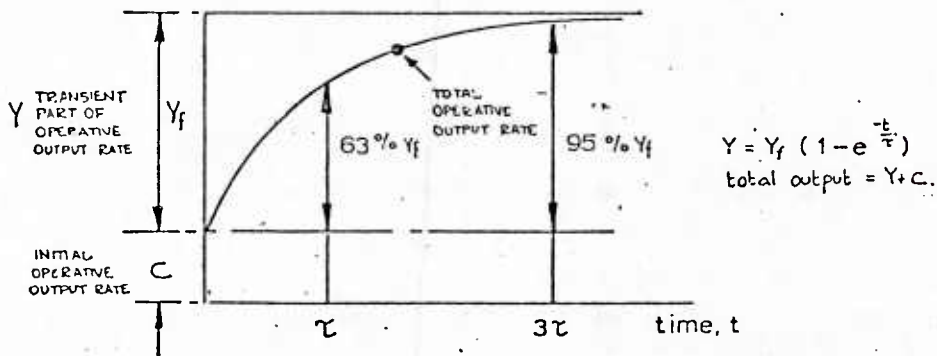

(c) Exponential form of learning curve

Fig. 2. Similarity between exponential form of learning curve and response of physical systems

TS 167

C66 Cost and Optimization Engineering
F.C. Jelen, Editor
New York: McGraw Hill, 1970

Chapter 9 - The Learning Curve, H. J. Behrens.

It is fundamental human characteristic that a person engaged in a repetitive task will improve his performance.

In a broad sense this quest for improvement is the basis of technological advancement which passes endlessly from generation to generation.

Chapter 12 - Optimization, M. S. Peters and F. C. Jelen.

Optimization or the urge for efficiency has a basic psychological origin. The human mind can confront a task or problem and recognize more than one action followed by a second phase, — the selection of what is considered the best course of action. The second phase is the decision step. The two steps taken together (recognition of alternatives and decision) constitute optimization. Optimization can be qualitative (judged by human preference) or quantitative (depicted by exact mathematical means). Optimization permeates society and technology to a far greater degree than is realized.

ANNEX 3

GOAL PROGRAMMING

In the Goal Programming Model in Figure A2, the $g_1, 1 = 2, 2, \dots$, are the goals to be achieved for the first set of m constraints or equations. This is called the goal constraint set. The d_1^- and d_1^+ are the possible deviations from the respective goals. Here, d_1^- represents an underachievement and d_1^+ an overachievement. Both of these cannot appear in the same goal equation; at least one must be zero. If both are zero, then the goal has been exactly achieved. The second set of p constraints represent non-goal restrictions which the model must satisfy at all times. The objective function Z seeks to minimize the deviations from the goals as much as possible, based on a priority scheme assigned to the various goals. In many cases, it may not be necessary to exactly achieve a goal. In the case of some goals, it might be permissible, even desirable, to exceed the goal. This preference may be reflected in the model by minimizing only the negative deviation d_1^- , or underachievement, in the objective function for the particular goal. Of course, both deviations are still present in the goal constraint. The same logic applies in reverse if it is desired to not exceed a particular goal or limit. In this case, only the positive deviation d_1^+ , or overachievement, is present in the minimization process of the objective function.

A scenario for illustrating the Goal Programming Model is simplified to a one-on-one engagement. A Red submarine (X), opposes a Blue high value force unit (Y). The Y commander has established the following conditions: The mission of Y is to conduct strike

STEP 1 - MISSION SURVIVAL GOAL CONSTRAINT

This is priority 1, in which it is desirable to minimize the underachievement of survival time (Fig. 14) as expressed below in the deviational variable d_1^- .

$$X_1 + X_2 + X_3 + X_4 + d_1^- - d_1^+ = 100 \text{ hours}$$

STEP 2 - Y DETECTION OF X GOAL CONSTRAINT

This is priority 2, in which it is desirable that Y detect and classify X prior to completion of tracking (X_3) by X. Thus it is desired to minimize the underachievement of this goal as expressed below by the deviational variable d_2^- .

$$X_1 + X_2 + X_3 - (Y_1 + Y_2) + d_2^- - d_2^+ = 0$$

STEP 3 - Y DETECTION AVOIDANCE GOAL CONSTRAINT

This is priority 3, in which it is desired to minimize the underachievement of detection time by X (X_1). This is expressed below by the deviational variable d_3^- .

$$X_1 + d_3^- - d_3^+ = 50$$

STEP 4 - OPDEC ABSOLUTE CONSTRAINT

(Not reflected in the objective function.)

$$X_2 + X_3 \geq 5 + 10 \alpha$$

However $\alpha = d_2^+$ (see Step 2, above)

Following appropriate substitution from Step 2,

$$10Y_1 + 10Y_2 - 10X_1 - 9X_2 - 9X_3 - 10d_2^- \geq 5$$

STEP 5 - OBJECTIVE FUNCTION

$$\text{MIN } Z = P_1 d_1^- + P_2 d_2^- + P_3 d_3^-$$

Figure A2. Steps Of Goal Programming Model Formulation

operations (A) in the objective area. Y must survive at least 100 hours to do A. It has also been estimated from the data base of timeliness imbalances that the delay of Y detection by X, (X_1) for 50 hours (the numbers in this scenario are illustrative), will greatly enhance the success of A.

Figure A3 shows the influence of operational deception on timeliness imbalance. If Y does not detect X until X has completed tracking (X_3) it is estimated, from prior analysis of timeliness imbalances, that it will take X five hours after X_1 to begin localization (X_4); that is, $X_2 + X_3$ is estimated to five hours. However, if Y detects and classifies X before X_3 it is estimated, on the basis of past imbalances, that by use of operational deception Y can delay X_4 by ten hours for every hour before X_4 that Y detects and classifies X.

The X commander has established that the X mission is to intercept and destroy Y.

Using the Y commander's conditions, it is now possible to show in Figure A4 the steps in formulating the Goal Programming Model that has as its objective the launching of a successful strike by Y (strike operations A).

The solution of the first goal programming run indicates the achievement of some goals and the exception of others. The solution identifies the input requirements (variables) necessary to attain all goals through analysis of the Simplex Tableau.

Although the results provide valuable information, it might be determined that if in reality the resources that are required far

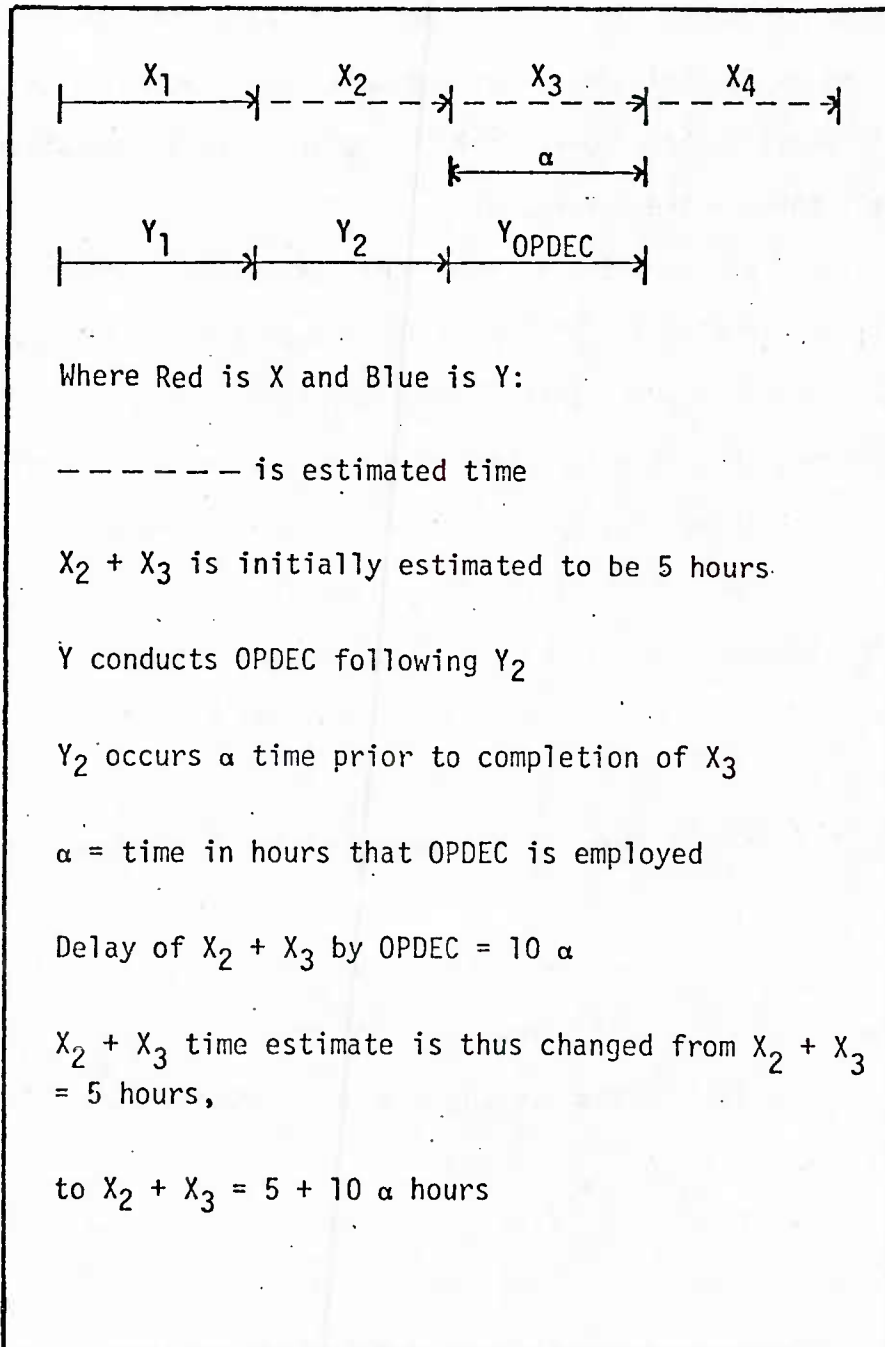

Figure A3. Influence Of OPDEC
On Timeliness Imbalance

$$\begin{aligned}
 \text{MINIMIZE } Z &= P_i(d_j^- + d_j^+) \\
 &\text{Subject to} \\
 a_{11}x_1 + a_{12}x_2 + \dots + a_{1n}x_n + d_1^- - d_1^+ &= g_1, \\
 a_{21}x_1 + a_{22}x_2 + \dots + a_{2n}x_n + d_2^- - d_2^+ &= g_2, \\
 \vdots & \\
 a_{m1}x_1 + a_{m2}x_2 + \dots + a_{mn}x_n + d_m^- - d_m^+ &= g_m, \\
 b_{11}x_1 + b_{12}x_2 + \dots + b_{1n}x_n &\leq c_1, \\
 b_{21}x_1 + b_{22}x_2 + \dots + b_{2n}x_n &\leq c_2, \\
 \vdots & \\
 b_{p1}x_1 + b_{p2}x_2 + \dots + b_{pn}x_n &\leq c_p \\
 x_j \geq 0, d_j^- \geq 0, d_j^+ \geq 0, i = 1, 2, \dots, m. \\
 & j = 1, 2, \dots, n.
 \end{aligned}$$

Figure A4. Goal Programming Model

exceed what is available or readily accessible, the priorities can then be changed and a new solution obtained.

With the results of general operational analysis, goal programming solution, post optimal analysis, and reiteration with variable priorities it is possible to conduct a quantitative appraisal of NCCS effectiveness. This will help to upgrade NCCS performance. The commander can seek new procedures, tactics, and strategies to support specific missions. The technical community has operational performance data that can be used to guide and justify new designs, trade-offs, and procurements.

RESULTS, CONCLUSIONS, RECOMMENDATIONS, AND IMPLICATIONS

a. Results

(1) Both the United States Navy and the Soviet Navy have C³ concepts that are based on system interaction of ashore and afloat nodes.

(2) The existing means of evaluating C³ performance does not test the full Red C³ System against the full Blue C³ System.

b. Conclusions

(1) The timeliness imbalance Measure of Effectiveness measures the operational performance of the afloat and ashore nodes of NCCS relative to the performance of the Soviet C³ System.

(2) The Measure of Effectiveness results can be used as factors for:

(a) Developing NCCS performance standards, e.g., readiness.

(b) Planning and monitoring real world operations.

(c) Supporting the articulation of operational requirements. These data can be understood and utilized as NCCS goals by both operator and technical developer alike.

(3) The relative nature of the NCCS appraisal rests on the assumption that Red C³ System performance can be estimated and used in free play exercises. The availability of threat staff expertise to simulate the Red C³ System during fleet exercises is critical to the usefulness of the appraisal methodology.

(4) Without the availability of a valid Red C³ System performance, there is only unilateral self-evaluation of the Blue C³ System. This means that we measure our performance only in terms of how much we think we are getting from available technology.

BIBLIOGRAPHY

- Presented by representative of Navy Electronic Systems Command.
"Soviet Ocean Surveillance System." CINCPACFLT Briefing,
1975.
- Cook, R.. "HULTECH Vulnerability Studies." Navy Ocean Systems
Center, 1977.
- Drandell, M. J.. "A Complete Forecasting Methodology for Manpower
Planning Utilizing Objective and Subjective Criteria." Academy
of Management Journal, September 1975.
- . "An Analysis of the Hoflander-Drandell Basic Model for
Insurance Management Utilizing Goal Programming." Presented at
the National Meeting of the American Risk and Insurance Associa-
tion, August 1975.
- Haiges, J.. "Cover and Deception." Briefings at Pearl Harbor, 1977.
- Harris, Goerge. "A Methodology for Appraising the Operational
Effectiveness of the Navy Command and Control System." Naval
Post Graduate School: Military Operations Research Symposium,
December 1977.
- . "Broadband Detection and Fixing." COMHUKFORLANT, May 1969.
- . "Human Factors in the Design of a Fleet Command Center."
Unpublished report, April 1978.
- . "Implications of the Mid East Crisis for the FCC." Unpub-
lished report, October 1973.
- . "Tactical Development for Acoustic Deception Devices."
ONR/COMTHIRDFLT, March 1973.
- Jelen, F.C.. "Cost and Optimization Engineering." New York:
McGraw Hill, 1979.
- Pitman, G. R.. "The Theory and Analysis of Conflict." Naval
Post Graduate School: Military Operations Research Symposium,
July 1975.

BIBLIOGRAPHY (Continued)

- Quade, Edward S. (Ed.). "Analysis for Military Decisions."
Chicago, Illinois: Rand McNally and Company, and Amsterdam,
The Netherlands: North-Holland Publ. Co., 1964.
- . "Analysis for Public Decision." New York: Elsevier
North-Holland, Inc., and Amsterdam, The Netherlands: Elsevier
Scientific Publ. Co., 1978.
- Wright, W. G.. "Operations Research." Briefings at CINCPAC, 1977.

PRELIMINARY THOUGHTS ON C³ SYSTEM MODELING AND SURVIVABILITY

Stephen Kahne
Department Systems Engineering
Case Institute of Technology
Case Western Reserve University
Cleveland, Ohio 44106
(216) 358-4466

DEPT. SYSTEMS ENGINEERING
CASE INSTITUTE OF
TECHNOLOGY

Case Western Reserve University
Cleveland, OH

Brosilow

Parke

✓ Buchner

Rose

✓ Haimes

✓ Krishnaprasad

✓ Kahne

~~Magdi "Survey of
Hierarchical Systems
Control" SMC Trans~~

✓ Leskowitz

✓ Loparo

Martin

✓ Mesarovic

Kahne et al "Automatic
Control by Distributed
Intelligence" Scientific
American, June 79.

Hierarchical System Theory

Resource planning

Industrial systems control

Global modelling

Multiobjective optimization

Stochastic systems analysis

Distributed computer control

System failure analysis

Overlapping hierarchies

Design of hierarchical structures

System diagnostics

System survivability

Survivability of distributed systems

Survivability

- No operationally useful definition or problem formulation
- Essential concept for C³I
- Components include -
 - maintainability
 - reconfigurability
 - graceful degradation
 - robustness
 - modularity in design and analysis
 - fault tolerance

Nature of distribution

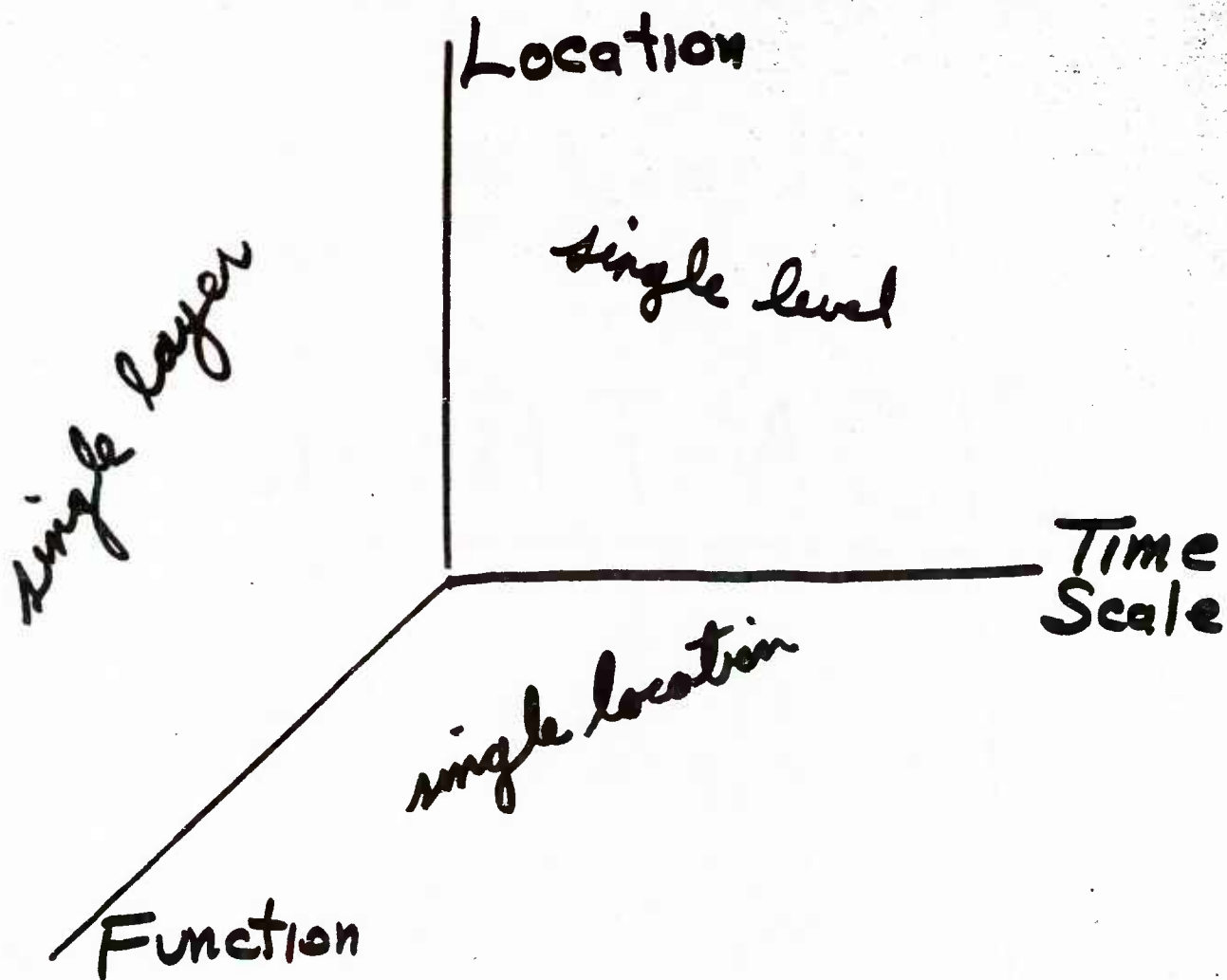

- hierarchies along axes
- distribution may be:

inherent
imposed

Design for

CONTROL

Models of C³I systems -

An object capable of receiving a finite number of inputs at discrete intervals and changing its internal state to one of several finite states in some probabilistic manner depending on these inputs. - stochastic automaton

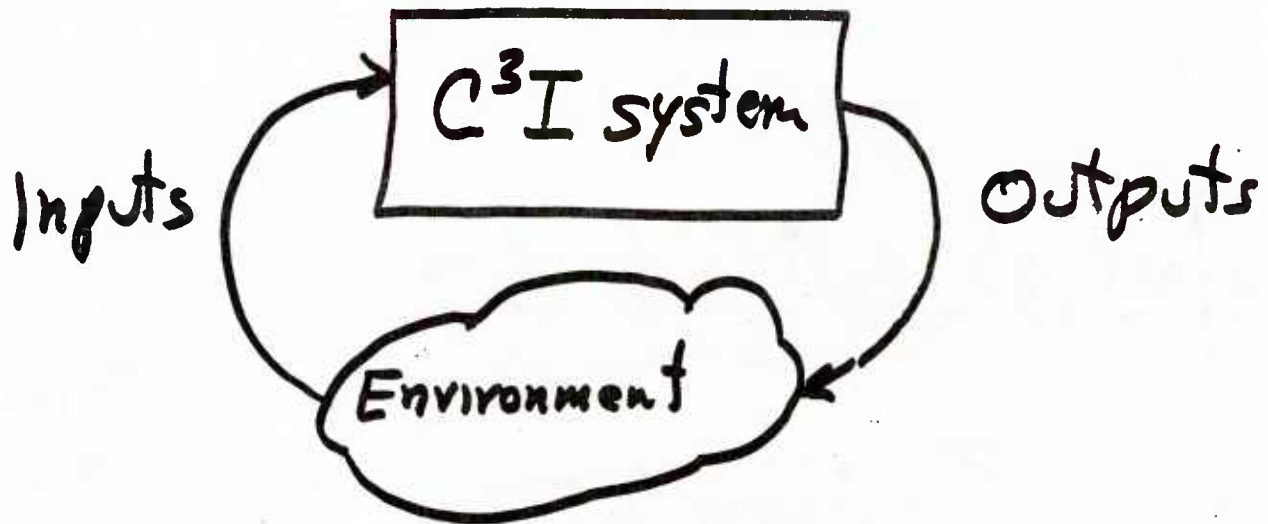

- Aggregation
- Alarm or failure states

Tolerance states: set of states
(for each mission) which must be
reached for mission success

Analyze probability of reaching
tolerance state.

Structure C³I system to "maximize"
that probability

Models of system failure

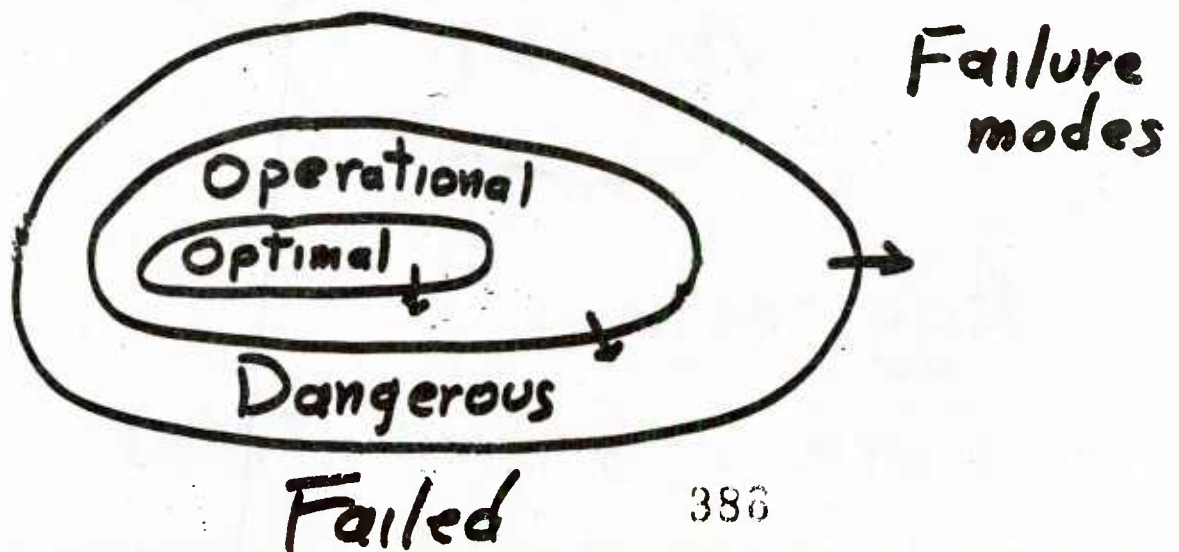

Failure states to be avoided by control strategies (transition prob.)

Need theory of failure in hierarchical structures

Overlapping hierarchies

Control migration strategies

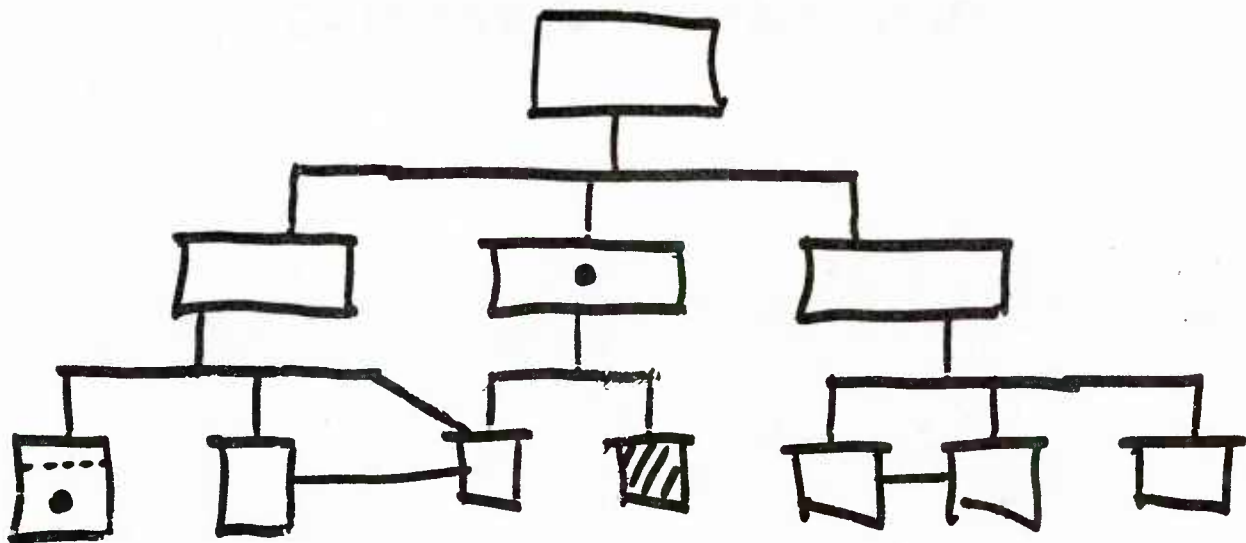

Control function migration

System diagnostics

Test beds

μ computer network simulation n.mPc

Fox lab - SPECTRUM: data biway based
process control network for
studies of distributed
hierarchical processes

SOME THOUGHTS ON NAVY COMMAND AND CONTROL
TECHNOLOGY BASE DEVELOPMENT

Robert C. Kolb
Naval Ocean Systems Center
San Diego, California 92152
(714) 225-6176

SOME THOUGHTS ON NAVY COMMAND AND CONTROL
TECHNOLOGY BASE DEVELOPMENT

R. C. KOLB
NAVAL OCEAN SYSTEMS CENTER
SAN DIEGO, CA

WHAT IS A C² TECHNOLOGY BASE?

HOW IS IT DEVELOPED?

WHAT ARE SOME OF THE CURRENT NAVY C² TECHNOLOGY DEVELOPMENTS?

HOW IS THE TECHNOLOGY BASE USED?

WHAT IS A C² TECHNOLOGY BASE?

CATEGORIES OF TECHNOLOGY BASE DEVELOPMENT

RESEARCH

"... IT PROVIDES FUNDAMENTAL KNOWLEDGE FOR THE SOLUTION OF IDENTIFIED MILITARY PROBLEMS. IT ALSO PROVIDES PART OF THE BASE FOR SUBSEQUENT EXPLORATORY AND ADVANCED DEVELOPMENTS IN DEFENSE-RELATED TECHNOLOGIES..."

EXPLORATORY DEVELOPMENT

"... DOMINANT CHARACTERISTIC ... IS THAT IT BE POINTED TOWARD SPECIFIC MILITARY PROBLEM AREAS WITH A VIEW TOWARD DEVELOPING AND EVALUATING THE FEASIBILITY AND PRACTICABILITY OF PROPOSED SOLUTIONS AND DETERMINING THEIR PARAMETERS. ..."

ADVANCED DEVELOPMENT

"INCLUDES ALL PROJECTS WHICH ARE MOVED INTO THE DEVELOPMENT OF HARDWARE FOR EXPERIMENTATION OR OPERATIONAL TEST. ..."

COMMAND AND CONTROL FUNCTIONS ARE PERFORMED THROUGH AN ARRANGEMENT
OF

- PERSONNEL
- EQUIPMENT
- COMMUNICATIONS
- FACILITIES
- PROCESSING

WHICH ARE EMPLOYED BY A COMMANDER IN PLANNING, DIRECTING, COORDINATING,
AND CONTROLLING FORCES AND OPERATIONS IN THE ACCOMPLISHMENT OF HIS
MISSION.

AN ARRANGEMENT OF

PERSONNEL

- DECISION MAKERS
- OPERATORS
- MAINTENANCE

EQUIPMENT

- HARDWARE
 - COMPUTERS
 - DISPLAYS
- SOFTWARE
 - OPERATIONAL
 - TRAINING
 - SUPPORT

COMMUNICATIONS

- VOICE
- DATA
- VIDEO

FACILITIES

- COMBAT INFORMATION CENTER
- COMMAND CENTER

PROCEDURES

- RULES OF ENGAGEMENT
- TACTICS

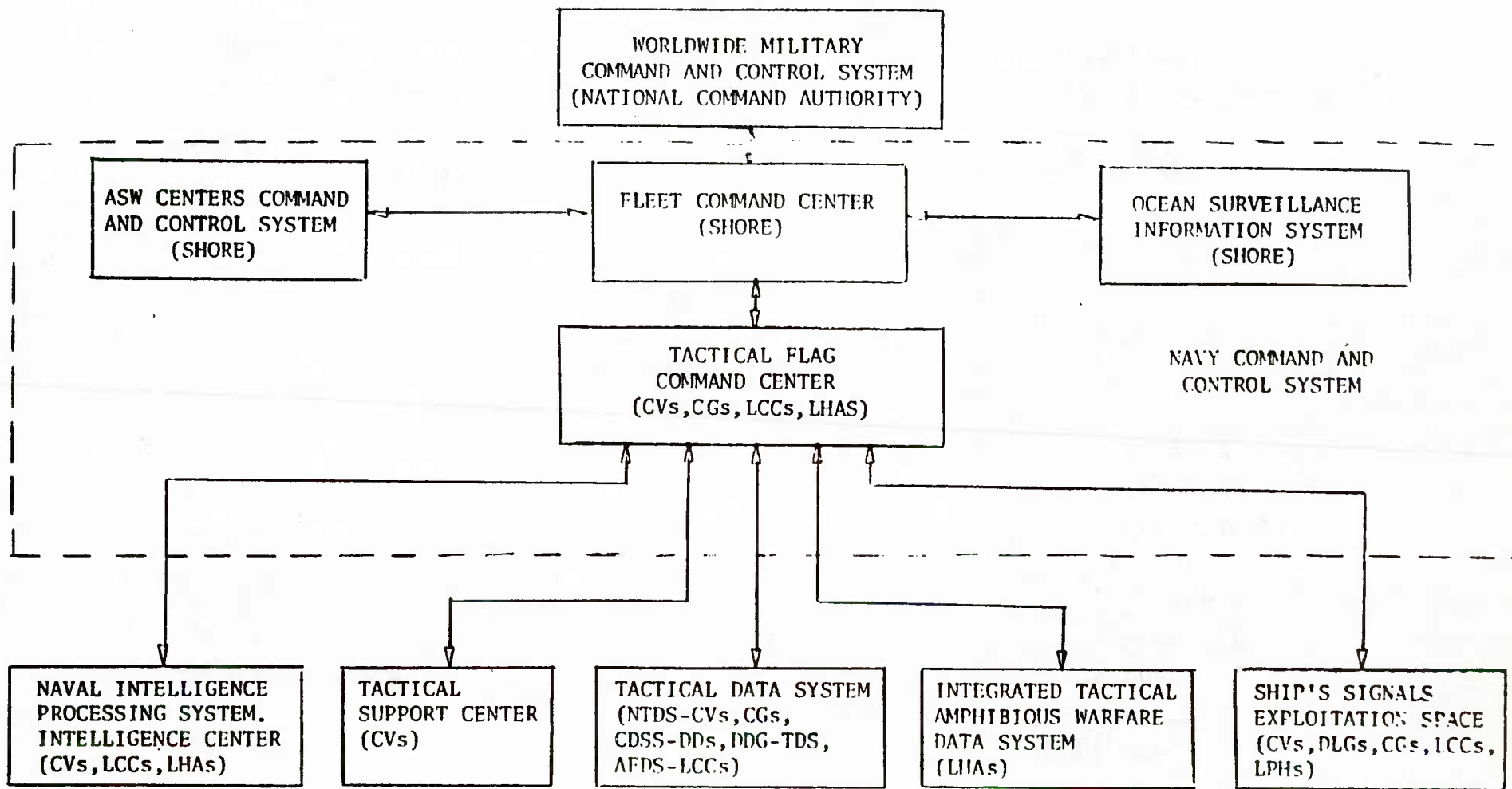

→ PRIMARY INTERFACE

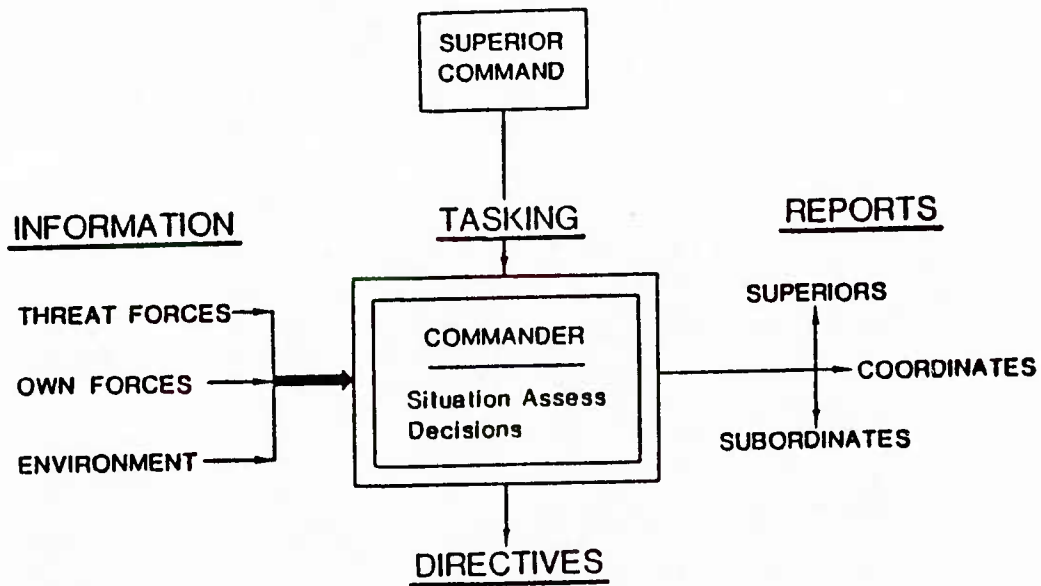

HOW IS IT DEVELOPED?

PROGRAM FORMULATION

DOD
CHIEF OF NAVAL OPERATIONS

NAVAL MATERIAL COMMAND
SYSTEM COMMANDS
OFFICE OF NAVAL RESEARCH

NAVY LABS
UNIVERSITIES
LABORATORIES

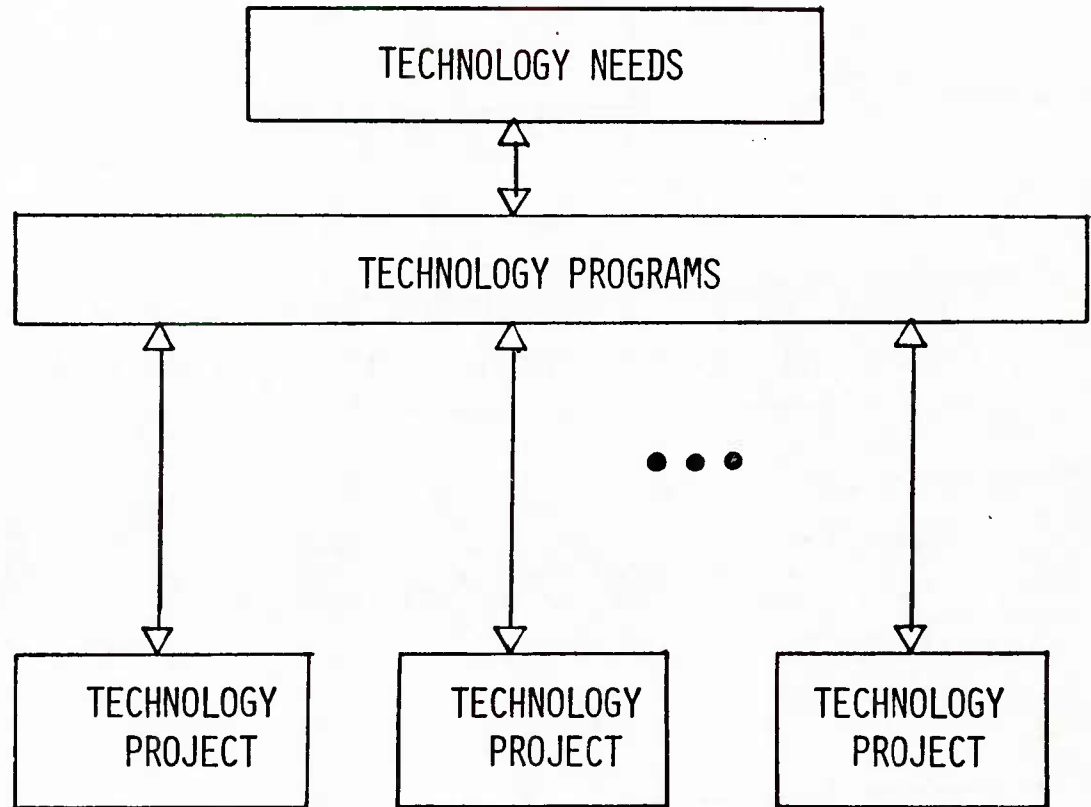

DEVELOPMENT PROCESS

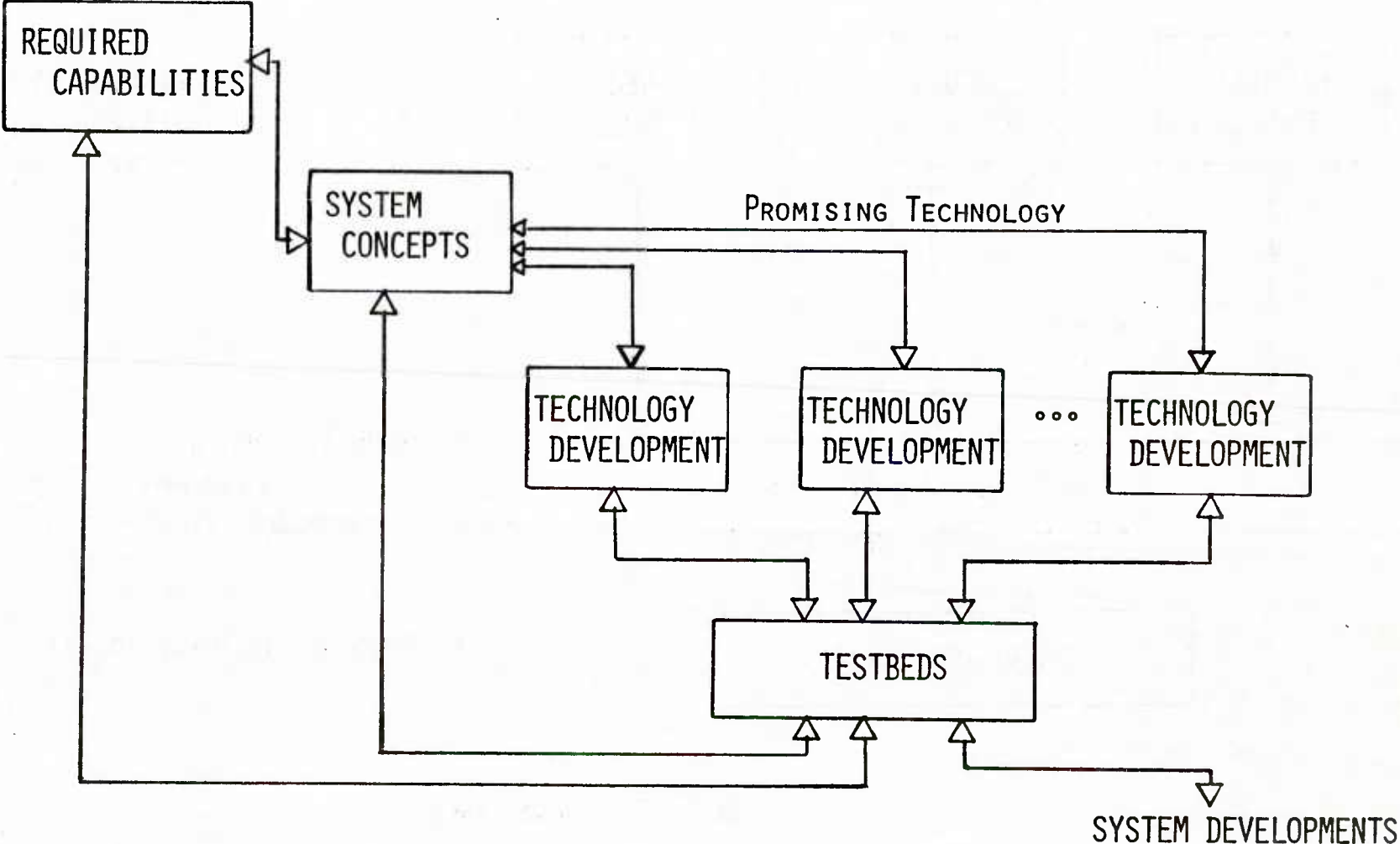

400

WHAT ARE SOME OF THE CURRENT NAVY C² TECHNOLOGY DEVELOPMENTS?

ADVANCED SENSOR INTEGRATION/TACTICAL DATA PROCESSING

CURRENT PROGRAM STRUCTURE

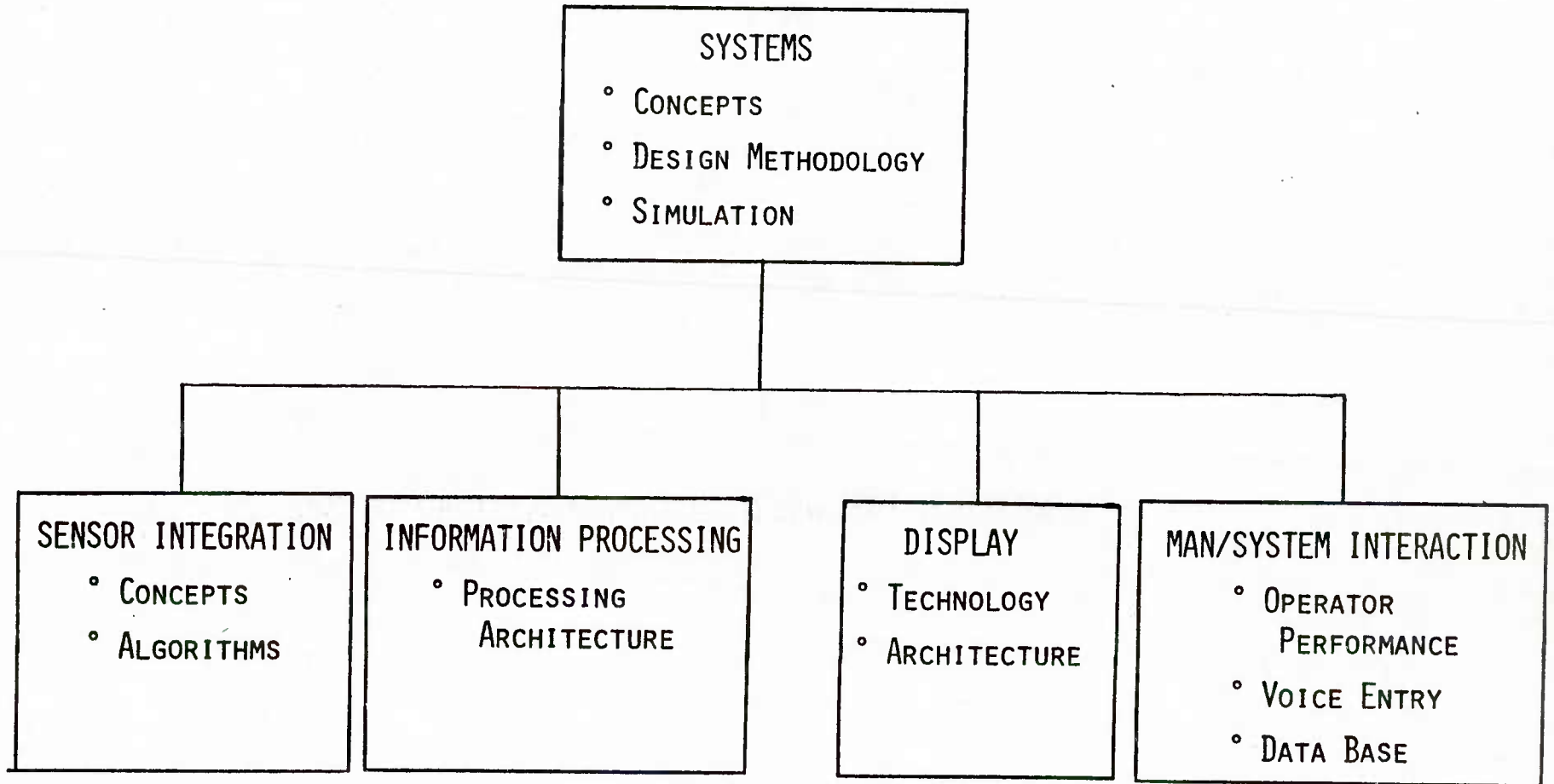

THE SHIP COMBAT SYSTEM SIMULATION (SCSS) Combat System Representation in the SCSS

Combat Systems are modelled as networks of NODEs, LINKs, and global data sets

- NODEs are decision &/or action points (e.g., radar, tracking module, missile launcher)
- Components in a Combat System usually are represented by a NODE in the SCSS
- NODEs are interconnected by LINKs
- Inter-NODE communication is via MESSAGEs sent over LINKs, or via global data sets
- NODEs are characterized by:
 - Input MESSAGEs
 - Output MESSAGEs
 - Functions
 - Misinformation model
 - Time delay model

THE SHIP COMBAT SYSTEM SIMULATION (SCSS) Phase 1 General Structure

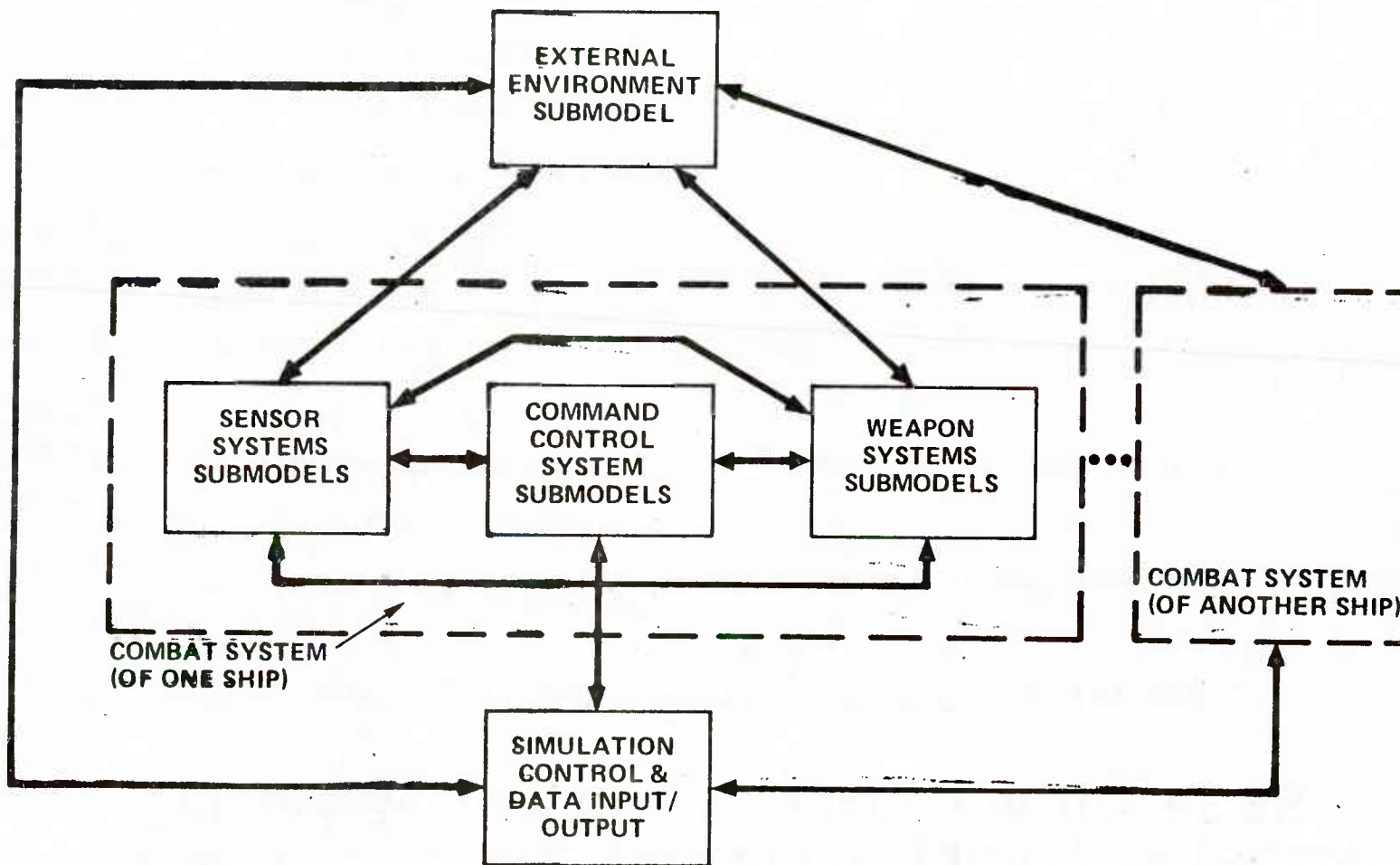

THE SHIP COMBAT SYSTEM SIMULATION (SCSS) Node/Message Structure

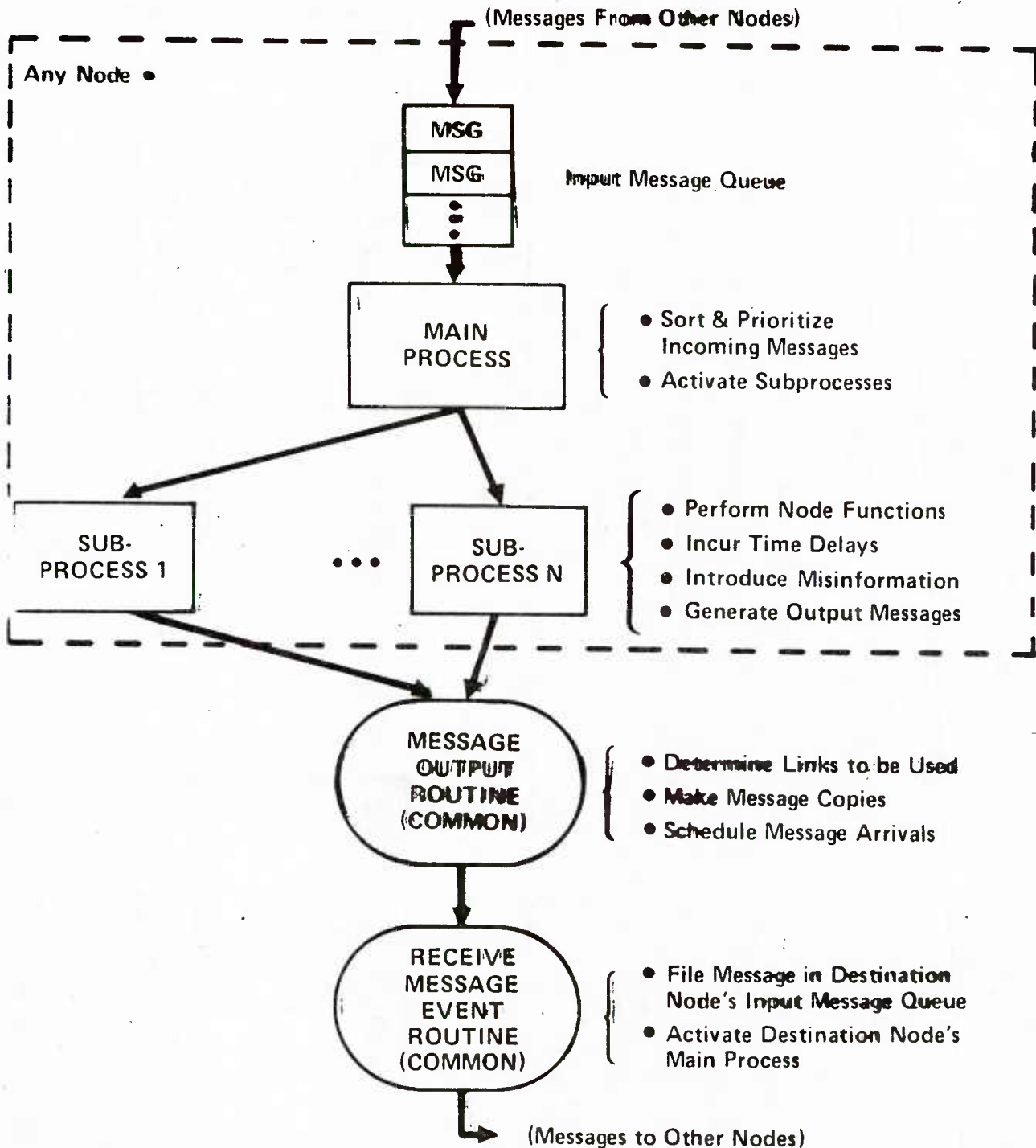

NOSC COMMAND AND CONTROL TECHNOLOGY PROGRAM
CURRENT PROGRAM STRUCTURE

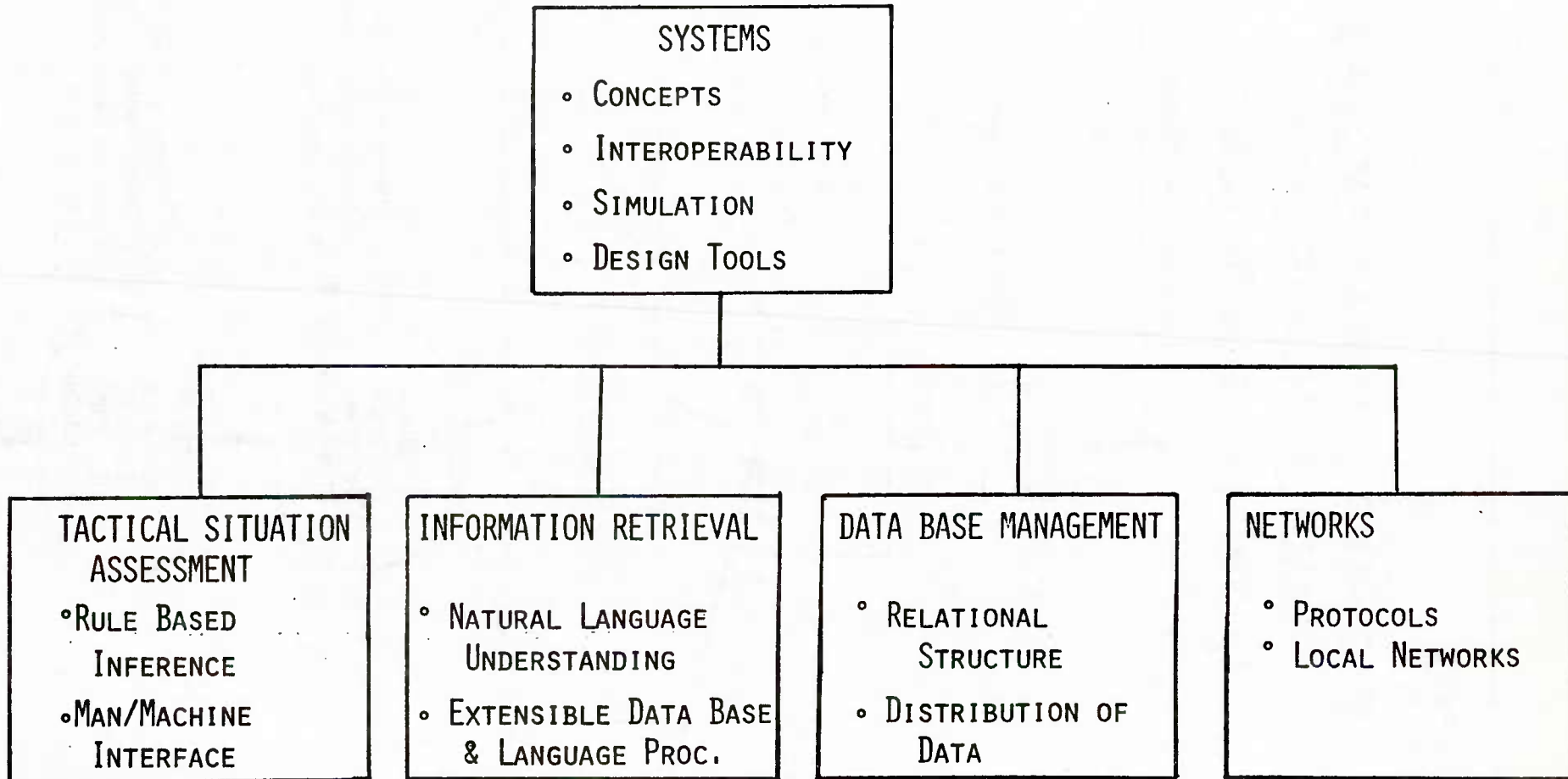

409

PROBLEM

- CHANGING REQUIREMENTS OF C² NOT ACCOMMODATED
- COMPONENTS OF EXISTING NCCS ARE "STAND-ALONE"
- MODIFICATION OF C² SUBSYSTEMS IS DIFFICULT
- MANUAL COMBINING OF DATA FROM SEPARATE C² SUBSYSTEMS
- INTERCONNECTION OF NEW C² SUBSYSTEMS WITH EXISTING C² SUBSYSTEMS IS DIFFICULT

LOCAL COMMAND CENTER NETWORK (LCCN)

OBJECTIVE: DEVISE A NEW METHOD OF IMPLEMENTING C² SUBSYSTEMS TO SUPPORT THE EVER-CHANGING REQUIREMENTS OF COMMAND AND CONTROL FOR SHIPBOARD ENVIRONMENT

APPROACH: COMBINE NETWORK AND DATA BUS TECHNOLOGIES, PROVIDING A FLEXIBLE TESTBED FOR INTERCONNECTION OF C² SUBSYSTEMS THROUGH 1990.

DESIGN, ANALYSIS AND SIMULATION OF A DISTRIBUTED SURVEILLANCE NETWORK

Richard Lacoss and Peter Green
Massachusetts Institute of Technology
Lincoln Laboratory
Lexington, Massachusetts 02138
(617) 253-7858

MASSACHUSETTS INSTITUTE OF TECHNOLOGY

LINCOLN LABORATORY

LEXINGTON, MASSACHUSETTS

Design, Analysis, and Simulation of a Distributed Surveillance Network*

By

Richard Lacoss

and

Peter Green

13 July 1979

*This work was sponsored by the Advanced Research Projects Agency of the Department of Defense.

DESIGN, ANALYSIS, AND SIMULATION OF A DISTRIBUTED SURVEILLANCE NETWORK*

By Richard Lacoss and Peter Green
Massachusetts Institute of Technology
Lincoln Laboratory
P.O. Box 73
Lexington, Massachusetts

ABSTRACT

The Lincoln Laboratory Distributed Sensor Networks (DSN) program is aimed at demonstrating innovative applications of new developments in computer networks and computer science to systems employing multiple spacially distributed inputs for target surveillance and tracking. Such a DSN would be made up of sensors, data bases, and processors distributed throughout an area and interconnected by an appropriate digital data communication system. It would serve users who are also distributed within the area and serviced by the same communication system. Problem areas of particular interest include: (1) Distribution of surveillance and system control functions, (2) Information flow within the system, (3) Adaptation to element failures, and eventually (4) Application of artificial intelligence methods to organize and control the system as well as to interpret surveillance data. Surveillance and tracking of low-flying aircraft by means of multiple sensors of limited capability and fields of view has been selected as a specific problem to focus the program.

*This work was sponsored by the Advanced Research Projects Agency of the Department of Defense.

The views and conclusions contained in this document are those of the contractor and should not be interpreted as necessarily representing the official policies, either expressed or implied, of the United States Government.

This paper reviews the general problem area, indicates why the surveillance and tracking of low-flying aircraft was selected as a specific application problem, and outlines a strawman system for that problem. The strawman uses many sensor nodes, each equipped with a computer, which communicate with each other using broadcast packet radio techniques. Some analysis of the strawman communication circuits is presented. The paper then goes on to describe the research into DSN systems, of which the strawman is an example, being performed by Lincoln. That research includes development of a three node experimental testbed, development of a software testbed to enable algorithms to be tested by simulating systems having many nodes, and development of algorithms for system control and sensor data interpretation.

1. Introduction

It is becoming clear that the use of computers as switching elements in packet communication systems in general and packet radio communication systems in particular offers the potential for significant improvements in military command and control systems [1]. A major related and unexplored question is how data from many distributed sensors can be analyzed, reduced, distributed, and integrated into such a system. This paper addresses this issue.

The Lincoln Laboratory Distributed Surveillance Networks (DSN) program is aimed at demonstrating innovative applications of new developments in computer networks and computer science to systems employing multiple spatially distributed inputs for target surveillance and tracking. Such a DSN would be made up of sensors, data bases, and processors distributed throughout an area and interconnected by an appropriate digital data communication system. It would serve users who are also distributed within the area and serviced by the same communication system. The case of particular interest is for individual inexpensive sensors which cannot view the entire surveillance area and can individually generate only limited information about targets in their field of view. The working hypothesis of the DSN program is that through suitable netting and distributed processing the information from many such sensors can be combined to yield effective and survivable and economical surveillance systems. The design may emphasize or optimize any of these attributes. Such Distributed Sensor

Networks represent an unconventional but important class of distributed computing systems.

Our particular problem of surveillance and tracking of low-flying aircraft or cruise missiles by means of multiple sensors of limited capability and fields of view has both tactical and strategic importance and is difficult to solve with traditional system approaches. The use of very many modest cost sensors may be the only alternative for a satisfactory ground-based system. The critical issues are how to interconnect and operate the system so that it can perform its function in a timely manner, have no single node failures which can disable the system, adapt to changing situations, and make the best use of available resources.

For small numbers of autonomous or nearly autonomous sensors the interactions are minimal and human operators can be used extensively for data interpretation as well as performing manually, by radio or telephone, the needed communications between sites and with the overall command, control, and communication system. This is the typical situation in practice now with radars. It works well when the radar has a large range, such as permitted with high flying aircraft, and when the need for information is predominantly local, such as in the case of the radars attached to a single surface to air battery. However the low-flying aircraft problem forces the deployment of sensors every few kilometers, if effective acquisition and surveillance is to be achieved. To give adequate warning of an attack, many hundreds of the sensors may be needed. The

normal mode of operation would completely fail in this situation so that computer based alternatives must be found. That is a major thrust of the DSN program.

We note that the normal mode of operation includes a person, a very advanced form of intelligence, at each sensor, as well as a computer. The normal mode, by virtue of this distributed intelligence, has some capability to adapt to changing circumstances and, with some exceptions, this capability is very survivable. A DSN must also have a distributed intelligence and be survivable. We are not concerned with systems which consist simply of large numbers of sensors with all processed or raw data communicated to a single command post where it may be further reduced and coordinated and distributed. Such a system would have a single point failure mode, which is unacceptable.

A strawman design for a system to accomplish distributed low-flying aircraft surveillance has been completed. The type of system is shown schematically in Figure 1. In the Figure the sensor type is left ambiguous to emphasize that a variety of sensors can be used, although the strawman system actually makes use of small acoustic arrays and small radars. As shown, the system consists of nodes distributed throughout an area with about 10 kilometer spacing. The entire system is netted together by packet switched radio broadcast communication using a single limited bandwidth channel. Each node, in addition to sensors and a considerable amount of processing and storage capability, includes a packet radio [2] with which

it communicates directly to nearby nodes and indirectly to more distant nodes. Similar systems for other applications have also been defined and are being investigated but will not be discussed here. The strawman system for low-flying aircraft poses some interesting problems. The sensors produce a very high data rate. This means that nodes must have considerable data analysis capability. However, each node may not have enough information to completely reduce the data, but must work cooperatively with its neighbors. The situation is further complicated by the fact that the information must be communicated to several command posts (users) which may have different needs.

As indicated in Figure 1 some users may be local and others may be remote from the DSN. In addition, an important functional distinction between the DSN, the users, and the command and control functions is somewhat obscured by the Figure. Figure 2 shows the more accurate functional situation representing the integration of the DSN and the rest of the command, control, and communication functions. The DSN contains considerable internal communications involved in the distributed sensor and computer system which reduces and distributes surveillance information. At some, in some instances all, of the DSN nodes the DSN is interfaced to the rest of the command, control, and communication network. Information flows from the DSN to such nodes and requests for services and information flow from those interfaces to wherever in the DSN they are directed.

The low-flying aircraft problem and the strawman system discussed above represent only part of the research effort. The strawman is one specific system upon which to focus. More details of its present status are given in the next Section. In the future it will be improved, adapted and modified as we better understand its capabilities and how to achieve many of the desirable system properties. How to achieve those properties is a fundamental distributed computer system question for a DSN. Other sections review other aspects of the ongoing program which will better identify and subsequently solve these general system questions as well as define and evaluate specific systems which could be developed and deployed for various military purposes. These other aspects include experimental work with a three node system, development of a software testbed, development and evaluation of techniques to obtain maximum information extraction from single and multiple node sensor data, and system adaptation with respect to the number and location of nodes with emphasis upon communication and user requirements.

Another aspect of our program, which is not directly discussed here, is the study of overall system problems, such as how well a DSN system detects and tracks targets under various scenarios.

DSN problems are being studied cooperatively by several groups, of which the Lincoln Laboratory group is one. We are oriented towards developing real and simulated distributed systems which can be used to test techniques and designs as they are developed. We also plan to develop and

test basic DSN methodology. An important part of our work will be to interact with other DSN researchers and to incorporate their ideas into our systems. Areas of interaction include: application of artificial intelligence to system operation, sensor data interpretation, and situation assessment; advanced detection and estimation technology; computer and communication hardware; special and general purpose protocols; and general developments in the area of distributed computer systems with weak interconnections.

2. A Strawman DSN for Surveillance and Tracking of Low-Flying Aircraft

To help identify and eventually solve realistic DSN issues we have produced an initial design for a system to detect and track low flying aircraft [3],[4]. Design objectives were for a system which would:

- Detect and track subsonic low-flying aircraft over large areas.
- Deliver timely information to users.
- Include cooperating multiple sensors and sensor types with limited individual capability.
- Automatically adapt to loss of system nodes and other changes in system configuration and element capabilities.
- be a system with highly distributed intelligence. There should be no single, or even small number of, fixed sites which are essential

for system operation.

Another long term objective is that the DSN should make the best use of the available sensors and facilities to satisfy user requirements. However the initial design was only required not to exclude such future possibility.

The system design meets these objectives to varying degrees. However, it is in the areas of automatic adaptability and distributed intelligence that the greatest opportunity for major improvements exist. In those areas in particular the strawman design leaves many questions unanswered and at best represents rudimentary capability based upon simple exploitation of sensor and communication redundancy. The strawman is not a completed system design but rather a foundation upon which to develop and test solutions to DSN problems. A brief overview of the strawman follows. A much more complete description and more discussion will be found in References [3] and [4].

Figure 3 shows the nominal deployment of DSN nodes. The basic separation of 10 kilometers was selected because of the target detection ranges which can be achieved by small acoustic arrays, reasonable radar detection ranges for very low flying targets in any but the smoothest terrain, and to obtain satisfactory communication connectivity. It is also consistent with expected target density and dynamics. The so-called sector nodes located every 50-kilometers in the grid are the nominal points of user interface and the interface to the general command and control functions. They were introduced into fixed locations for initial design and

studies although in principal any node could become such an interface.

Figure 4 shows the hardware associated with each node of the DSN. The small acoustic array consists of 10 microphones in a 3-meter area. It can be used to measure sound arrival direction and frequency content as a function of time. The radar is small and measures both range and azimuth, although azimuth resolution is limited. The Figure does not represent a detailed design but rather a general indication of the computation power which might be required at a DSN node. The parallel processor at the bottom is required to accomodate extensive acoustic and radar signal processing (tens of millions of floating point operations per second) while the processor in the center is designated more general tasks and tasks which do not easily decouple into indepenent parallel tasks.

Several kinds of communication service are required in the basic DSN system. We briefly discuss here single hop service which is required for local exchange of information between DSN nodes, and multiple hop report service to deliver information to sector nodes. In the strawman both are built upon a patterned sequence of node transmissions designed to avoid serious self-interference by the system.

The arrows in Figure 5 indicate the nodes which could receive a broadcast message from the node in the center of the Figure. More distant nodes will not receive the broadcast due to a combination of factors including the transmitter power and local propagation problems. In addition local propagation problems may exclude even some of the shorter

paths shown and even the useable paths may have substantial error rates. The receivers can detect errors and messages with error are just discarded. This is very different from the situation of a closely coupled distributed processor. By reciprocity the node in the center will be able to receive broadcasts from all of the nodes at the head of the arrows. Thus, it will be able to collect sensor and higher level information from those nodes to form its own best picture of the local situation. The basic design permits each node to broadcast locally significant information once each second. By repeated transmission and because sensor information is generally redundant, nodes receive and make use of substantial sensor information to formulate a local picture of the situation. It is worth noting that much of the DSN traffic is from one source to many receivers. As a result the usual one-to-one acknowledgement protocols are not valid and could saturate the channel. Moreover much of the traffic is non-critical in the sense that many messages must get through but the loss of a single one is generally not significant. The exception to this insensitivity to lost messages is low rate control and especially high value low rate surveillance traffic, which we do not discuss here except to note that it must rely upon separate services or make use of higher level protocols.

As noted above a potentially serious problem is self-interference. If traffic is high and channel access is not controlled the communication throughput can drop to almost zero. The strawman system communication requirements, relative to the assumed available communication capacity, are significant. A solution to this problem is to use a patterned sequence of

broadcasts such that they cannot interfere with each other. It may be that this will not be required and more random access to the channel will be adequate, but to be conservative we have constructed such a sequence for the nominal strawman configuration to indicate that it can be done and is not very complicated. The sequence is shown in Figure 6. In that Figure the entire DSN is grouped into areas shaped like a rhombus containing some 25 nodes. Each node in a rhombus has a unique label but the pattern of 25 is repeated throughout the DSN. The label indicates the order of transmission, for example, 1A...1F, 2A...2F, 3A...3F, 4, 5A...5F.

The strawman design is built upon several such communication sequences designed to avoid self-interference for several specific system functions. For example two functions are the local, one-hop, distribution of information mentioned above and the flow of surveillance information to sector nodes which is discussed below. In general the sequence is repeated once each second for each of the major system functions.

An important point to note is that the sequence of Figure 6 is a specific one for a specific situation. The self-establishment of such a sequence for an arbitrary system is presently an important and unsolved problem. It is part of the general startup and adaption problem which will receive much attention in future research. In the current design, a node broadcasts a message of 1500 data bits during its respective slot in the prescribed transmission sequence.

Report delivery to sector nodes (users) is more complex than the simple one-hop local distribution of information. The local distribution can be accomplished by no more than the establishment of a non-interfering pattern. However, the delivery of reports in general is a multiple hop problem. The initial approach adopted in the strawman for reporting purposes is to assign areas of interest to all of the nodes in the DSN. These areas may be larger than the coverage of the sensors locally attached to the node and may also exclude some of the coverage area of its own sensors. Once each second, conforming to a non-interfering broadcast pattern, each node broadcasts a report about its area of interest. Neighbors, who have properly coordinated areas of interest, hear the report, incorporate the information into their data base, and shortly (when their turn in the pattern occurs) transmit their own message. Each node thus acts as a very high level intelligent repeater.

We have run Monte-Carlo analyses of the flow of information from arbitrary nodes to sector nodes and have confirmed that simple strategems such as defining the area of interest to be all space within 30-kilometers of a node will work even with substantial numbers of nodes being non-functional. However, algorithms to establish optimal areas of interest and rules to get the best report flow are important areas of future research.

The examples we have considered serve to establish that the idea can work but the general configuration and load adaptation strategy require further effort. Also, a critical topic of future research is the exact or

approximate decomposition and distribution of such algorithms so that the system can self-organize without the need of a pre-defined central intelligence.

Although the strawman generally meets the basic system requirements it is more of a starting point for further detailed design and evaluation than a finished product. It appears to be satisfactory from the point of view of sensors and a deployment which is physically capable of the surveillance and tracking function. However, in its present state it does not furnish adequate answers with respect to the more difficult distributed processing and adaptation issues. We summarize here, in the form of requirements upon the DSN nodes, some topics which require more work.

- The nodes should individually and cooperatively make adaptive use of the communications facilities to optimize the transfer of high-level information (not data).
- The nodes should make adaptive use of their sensors and processing power to extract the maximum amount of information about the tactical scene.
- Nodes should share processing and decision making in a manner that adapts to the information requirements of the operators, the tactical situation and the functionality of the nodes at that instant of time.
- Nodes should have the ability to work with, combine and transfer incomplete information to the operators.

-Nodes should adapt their processing and communications strategies as nodes are eliminated, added or moved, communications fade, or information requirements change.

Overall the system is distributed and adaptive. The question of how much decentralization is optimal is still open. At any time, a hierarchy must exist to perform useful work. How it should be established and adapt is a major question in this research.

3. The Three Node Experiment

We are undertaking a modest three node experiment to demonstrate in the real world the cooperative real time detection and tracking of aircraft. This will help us to evaluate the effectiveness of cooperative processing techniques in tracking low flying aircraft.

For this initial experiment we have chosen to use acoustic sensors rather than radar sensors. There are three reasons for this choice.

First, one of the major characteristics of a DSN system should be its ability to work with incomplete information. Normal monostatic radars give rather complete position information for targets which they detect. Two or more can be used to improve location estimates but there is no fundamental need to use more than one to obtain a useful location. Very simple and perhaps multistatic radars giving more limited information could be considered. However, such sensors are not currently available and would

need to be developed. Acoustic sensors on the other hand give much lower quality data, and at least two cooperating nodes are needed to determine target position. This allows two primary aspects of the DSN to be tested on a small scale with little or no sensor development, namely cooperation and working with limited capability sensors.

Second, acoustic sensors are passive. As such, they are preferable to radars in some tactical situations, such as for detecting initial space penetration. However, the technology for extracting sensor information is not as well developed as for radars, and these techniques need to be developed if acoustic sensors are to be used in a DSN system.

Third, small acoustic arrays are a potentially important military surveillance tool for both low-flying and ground targets. Their use in our experiments will give important evaluation information independent of their DSN role.

Each experimental node will have an array of microphones, a mini-computer, an array processor and a packet radio as shown in Figure 7. As shown in Figure 8, each of the nodes will be connected back to the PDP-11/70 which we currently use for simulations and which itself is connected to the ARPA net [5] [6]. Different algorithms will be remotely loaded into the nodes and their performance monitored. Access to the experiment will be from any site on the ARPA net as well as from the PDP-11/70.

With this experimental setup, we hope to demonstrate adaptive, cooperative tracking of aircraft by a few nodes.

4. The Software Testbed

Experimental deployment of more than a few nodes is an expensive, major undertaking. Yet much of the useful behaviour of these systems only appears with many nodes [7]. To enable us to test algorithms in a multi-node configuration we are developing a software testbed.

This testbed will run the actual node algorithms as tasks. It will simulate the sensed environment by running other special tasks. Also it will simulate the effect of degraded communications.

There are expected to be a large number of tasks running to perform a simulation. As such the simulation cannot be run in real time. Each event, such as a sensor input or a message transmission, will be tagged with the simulated time at which it occurs. Then the running of the tasks will be keyed to this simulated time. In this way the simulation can be run in pseudo-time while maintaining event synchronism.

The running of the tasks is controlled by a kernel. For efficiency, the tasks are run in a pseudo-time sequence, rather than in a time sliced mode. When a task is run, it works on all data accumulated, emits time stamped messages, and only stops when it needs more data. It then communicates the next pseudo-time at which it expects to run to the kernel.

The kernel uses this information to run tasks in pseudo-time order. This approach helps overcome the swapping problem. By making sure that a task runs for as long as possible once in core, the swapping is minimized, as is the time to run a simulation.

The kernel manages the messages between the tasks. It also manages the running of the hardware simulation tasks to ensure that the correct input activates the tasks.

By using these techniques, we expect to be able to test algorithms in simulated experiments having many nodes. This is especially important with adaptive algorithms which can develop undesirable cooperative modes.

As an adjunct to this work, we are also developing some data description languages. These languages enable the user to rapidly describe different tactical scenarios, with different sensors and communications.

5. Algorithms and Analysis

In addition to developing experimental facilities and software testbeds for distributed sensor network algorithms, Lincoln is developing and evaluating algorithms for experimental and software testbed use.

One of the major areas of work is that of adaptive broadcast communications. As discussed in the strawman design section of this paper (Section 2), in a DSN network each node can broadcast messages. These messages are heard by several other nodes. The problem is to develop node

algorithms that will allow the transfer of information by this means to one or more requestors of information. A general overview of a patterned approach to information distribution has been described as has the need for much more investigation of how the system can accomplish its communication without the need for supervisory intelligence overlayed on the network. We have initiated research on how each node can be treated as an individual with intelligence, that finds his place in the system hierarchy by mutual negotiation.

We have been studying the "Rings of Power" algorithm. In this algorithm, each command center is appointed a center of power. It in turn appoints all nodes that can directly communicate with it as its "chiefs of staff". These in turn appoint their subordinates, and so forth as the rings of power spread out until they meet the borders of the network or another circle of power.

Subordinates communicate to the superior that is the least number of hops away from the center of power. If the superior is eliminated by enemy action or failure, then the subordinates try to find a new superior. If not, they become quiescent and wait until a new superior develops and is heard.

This algorithm is self starting on a randomly placed network. Some Monte-Carlo simulations have been performed in a situation with only one center of power which shows that it adapts well to network failures. Much more work needs to be done, in areas such as power contention between

leaders for the use of subordinates, negotiation of communications time allocation, and interaction with information requests. However, these decentralized adaptive algorithms do seem to offer excellent performance potential and a reduction in the total broadcast traffic in the system.

We have also been evaluating algorithms for sensor data reduction. These involve two parts, the correlation and processing of sensor inputs to develop plots of signal power as a function of time and other target related parameters and the extraction of possible target locations from these plots. For radar the target related parameters could be range and azimuth. For an acoustic array the parameters are frequency and signal wavenumber. In the case of acoustic sensors the extraction of target data must be done by correlating the plots from two nodes.

Current activity is focused upon acoustic array data. Initially we are studying non-adaptive extraction algorithms such as that of Capon [8] for acoustic frequency-wavenumber analysis, simple peak pickers for detection [9], and simple multiple site acoustic location and tracking algorithms [10]. However, in the future we hope to study adaptive algorithms and an artificial intelligence approach to the processing and interpretation of the sensor data. At the very least we will consider how to make better use of time continuity of events to improve performance and perhaps reduce processing loads.

REFERENCES

- [1] "C-cubed Research at DARPA," Colonel David C. Russel, USA; Signal: Journal of the Armed Forces Communications and Electronics Association; pp. 38-46 (March 1977).
- [2] "The Organization of Computer Resources into a Packet Radio Network", R. E. Kahn, National Computer Conference, 1975; pp. 177-186; (1975).
- [3] Distributed Sensor Networks Semiannual Technical Summary Report, Lincoln Laboratory, M.I.T. (30 September, 1978).
- [4] "Strawman Design for a DSN to Detect and Track Low Flying Aircraft;" R. Lacoss and R. Walton; Proceedings of Conference on Distributed Sensor Networks; Carnegie-Mellen University (December 1978).
- [5] "Resource Sharing Computer Communications Networks", Robert E. Kahn; Proc. IEEE, Vol. 60, No. 11, (November 1972).
- [6] "Resource Sharing with ARPANET", Edward P. Schelonka, National Telecommunications Conference 1974 Record; pp. 1045-1048; (1974).
- [7] "Distributed Intelligence for Situation Assessment," F. Hayes-Roth, and R. Wesson; Proceedings of Conference on Distributed Sensor Networks; Carnegie-Mellen University (December 1978).
- [8] "High-Resolution Frequency-Wavenumber Spectrum Analysis," J. Capon; Proc. IEEE Vol. 57, No. 8 (August 1969).
- [9] "Single-site Detection and Target Parameter Estimation", P. Demko; Proceeding at Conference on Distributed Sensor Networks; Carnegie-Mellon University (December 1978).
- [10] "Multi-site Acoustic Location", Robert Walton; Proceedings of Conference on Distributed Sensor Networks; Carnegie-Mellon University (December 1978).

FIGURE CAPTIONS

1. Distributed Sensor Network for low level air surveillance.
2. Relationship between the DSN, including its internal communications, and the users interfaced to a general command and control communication network.
3. Nominal distribution of strawman DSN nodes.
4. Strawman-node hardware configuration. Computer configuration based upon current commercial technology and is intended only to indicate that although node requirements are substantial they are easily within current state of the art.
5. Basic strawman communication links. Arrows show greatest number of nodes which might receive a direct broadcast from the central node. In practice not all links will be useable and even those which are may have substantial error rates.
6. Strawman communication pattern for local exchange of information between nodes and for accomplishing the flow of information from nodes to sector nodes. Situation shown for nominal system state and geographic distribution of sector nodes.
7. Experimental DSN node to be deployed in 3 node experiment.
8. Three node experiment.

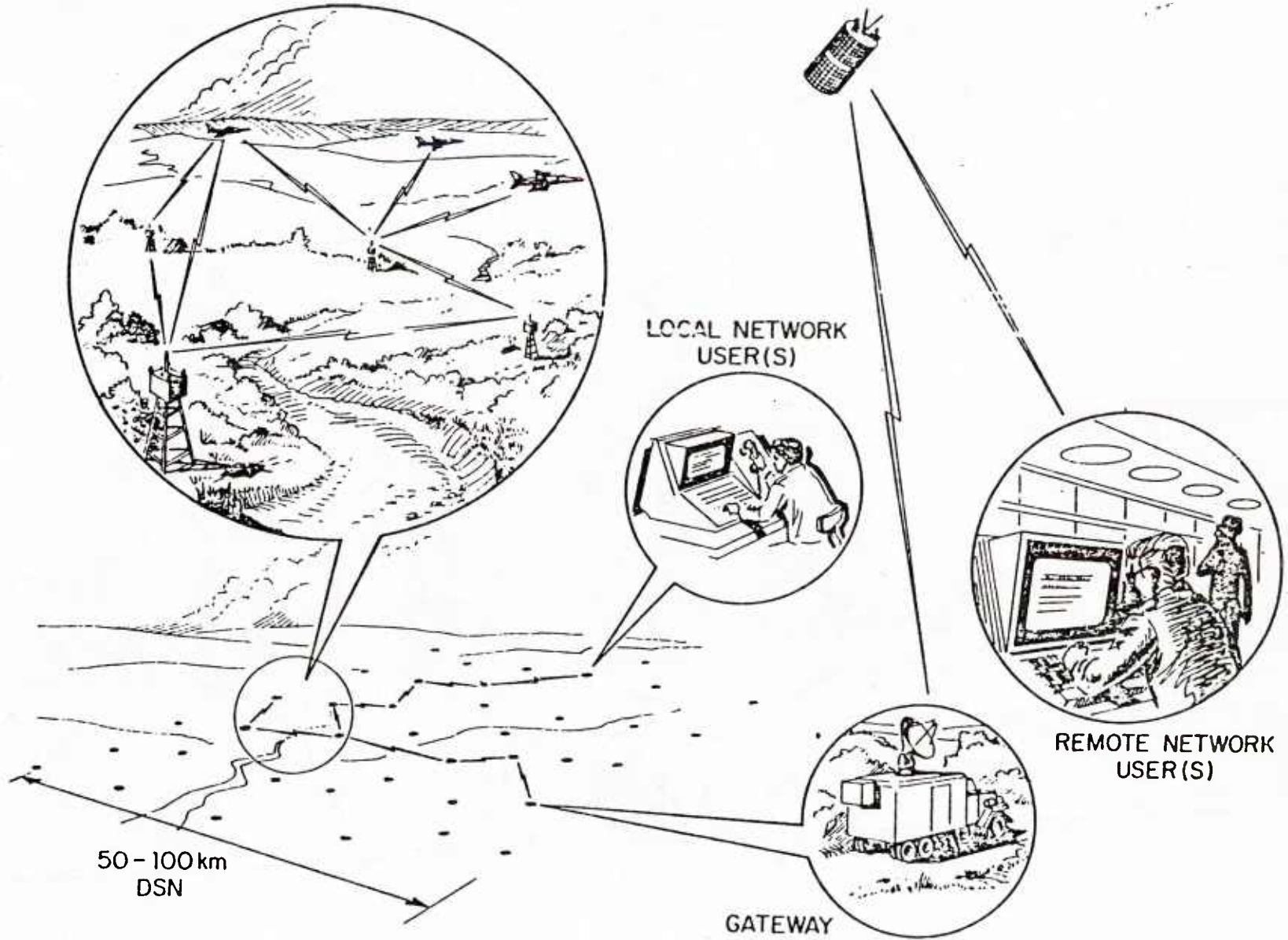

DISTRIBUTED SENSOR NETWORK LOW-LEVEL AIR SURVEILLANCE
FIGURE 1.

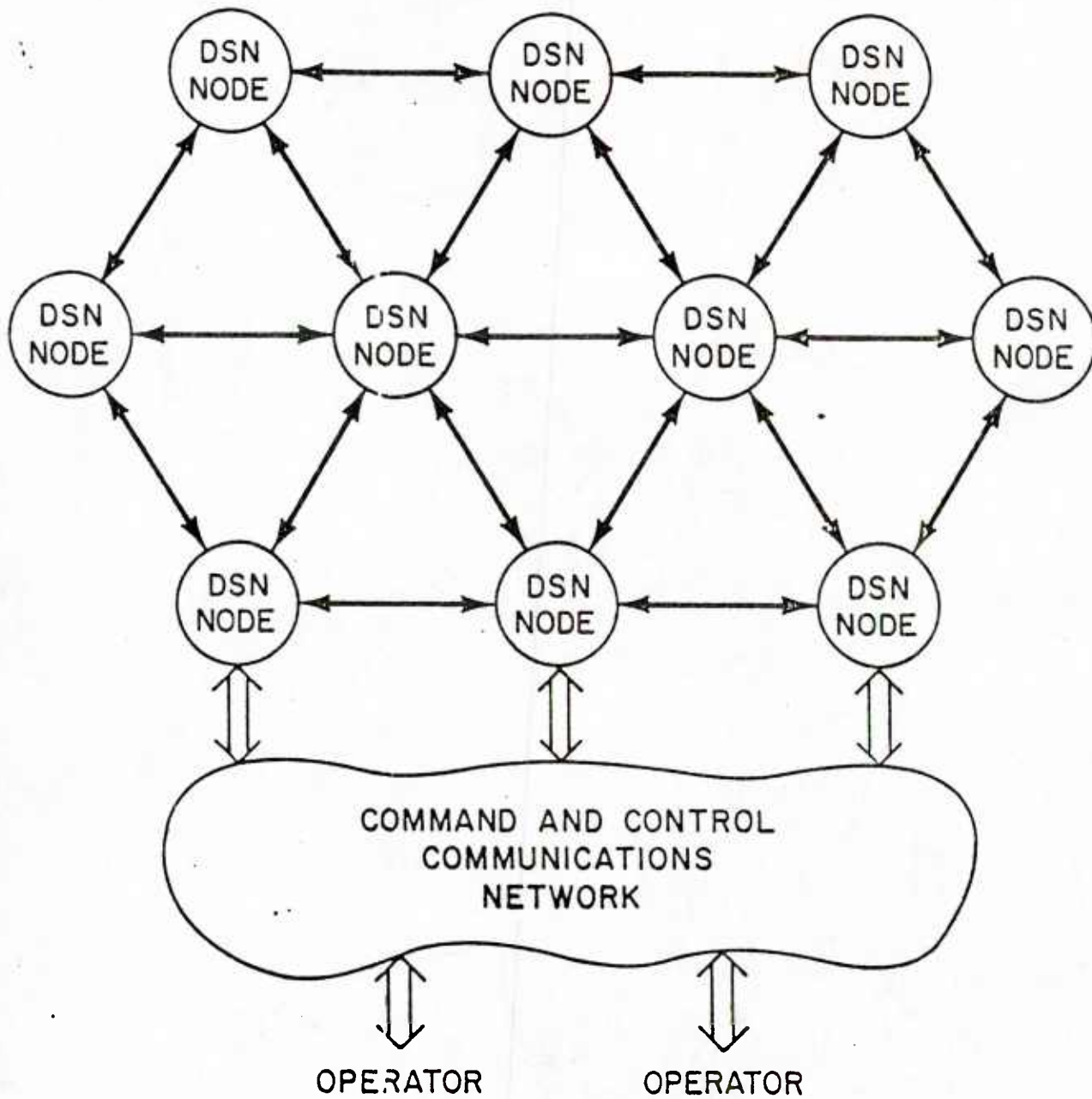

FIGURE 2.

• NODE

⊙ SECTOR NODE

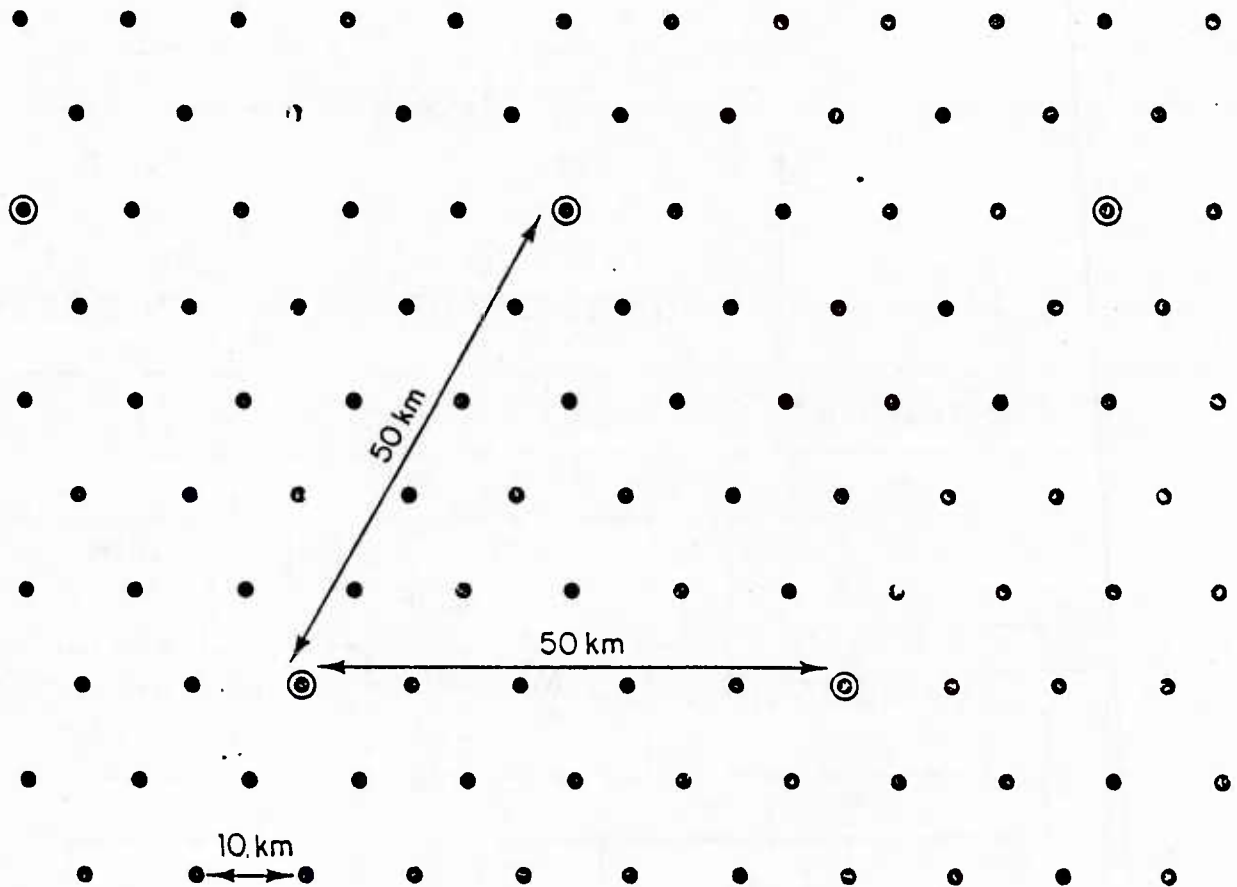
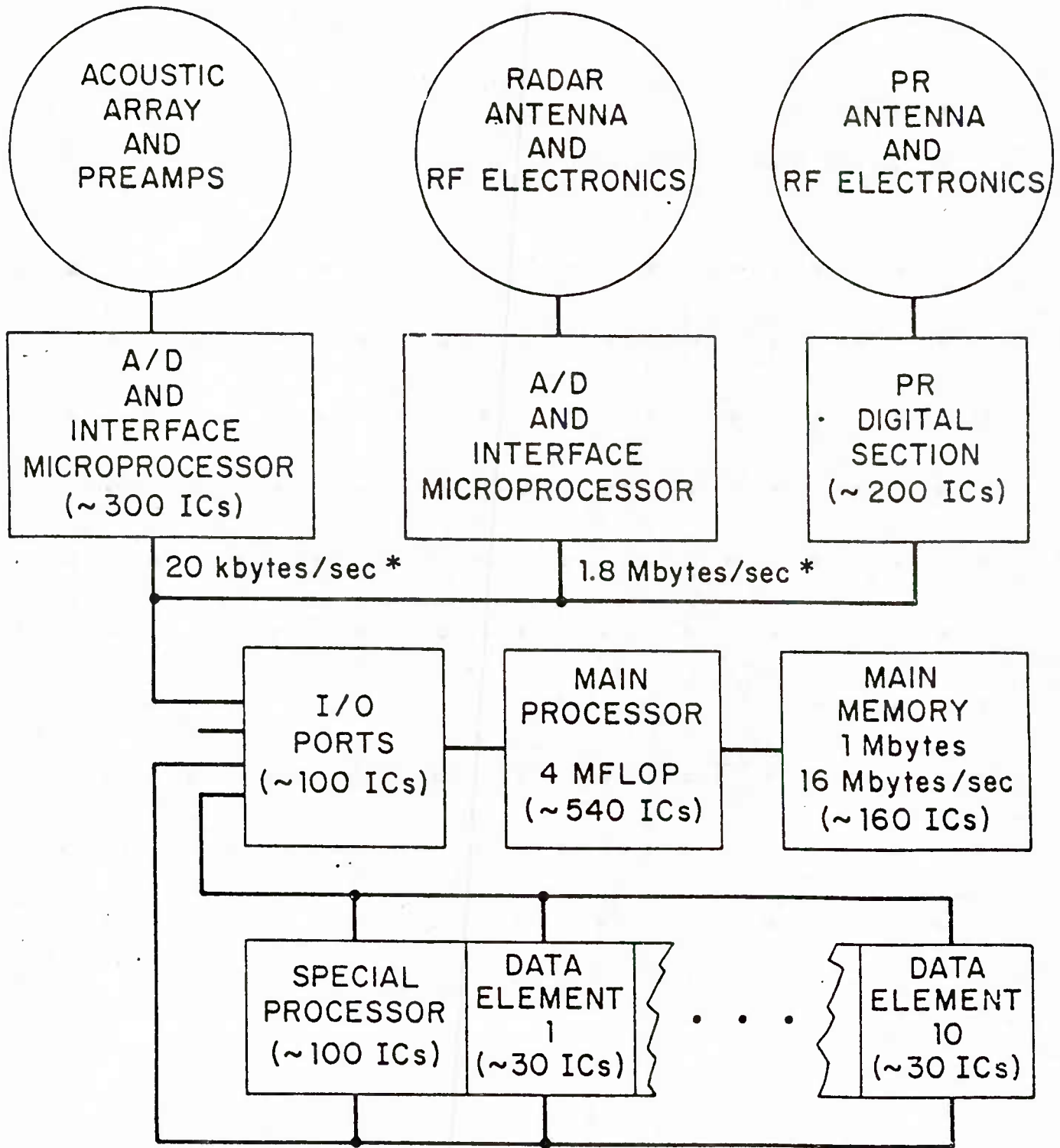

FIGURE 3.



* AVERAGE RATES

FIGURE 4.

18-00-15709

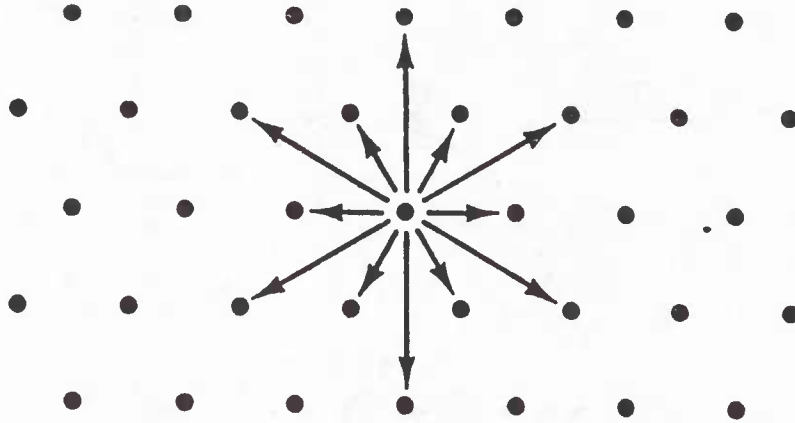
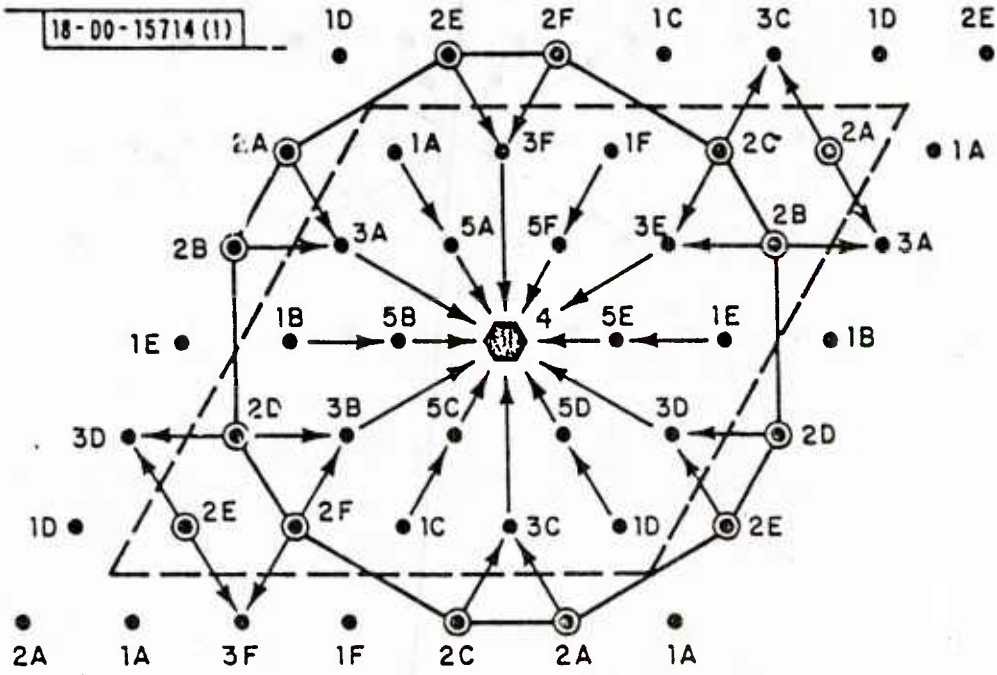

FIGURE 5.

18-00-15714 (1)



- DSN NODE (⊙ EQUIDISTANT BETWEEN SECTOR NODES)
- COMMUNICATION PATTERN CELL
- ENCLOSURES NODES REPORTING TO THIS SECTOR NODE AS CLOSEST SECTOR NODE

FIGURE 6.

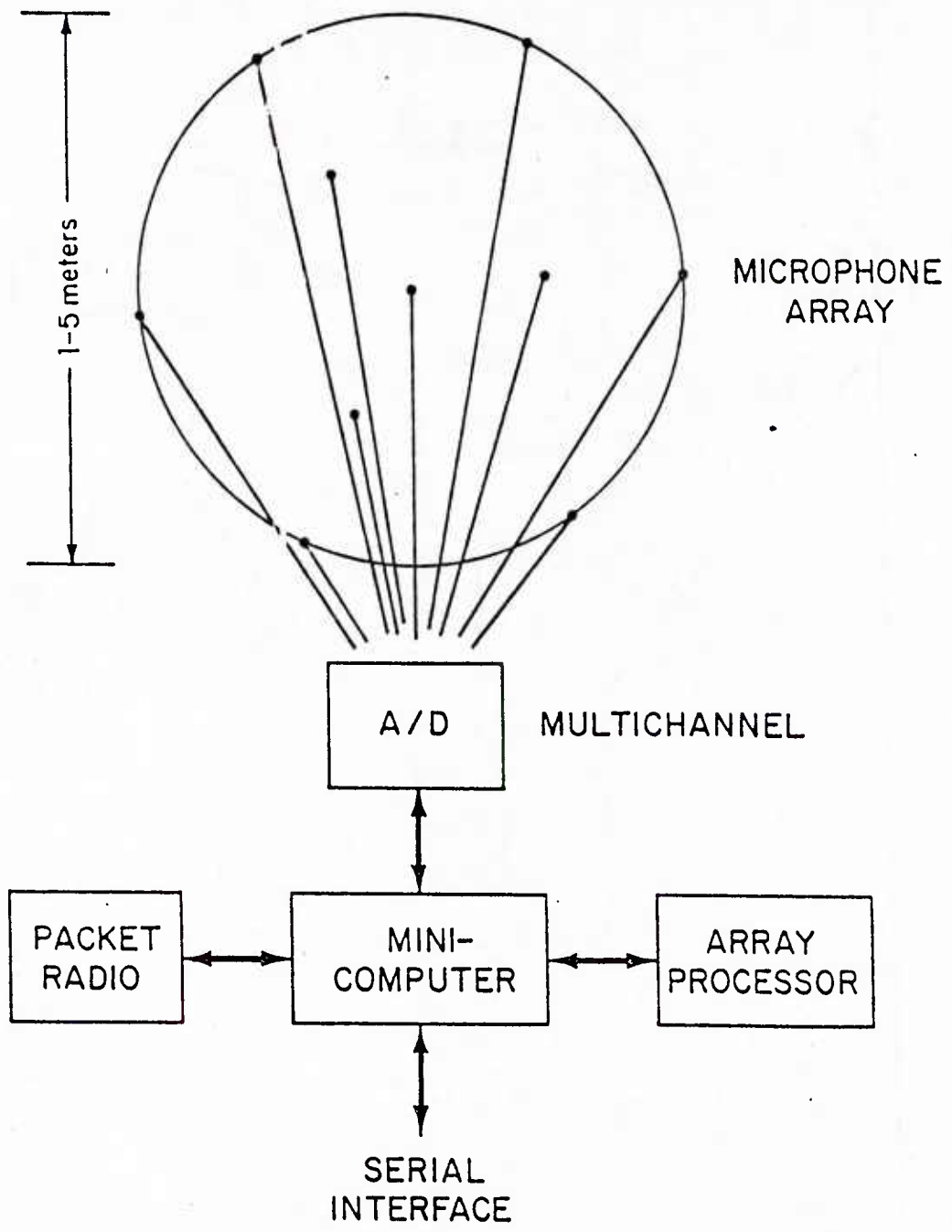

FIGURE 7.

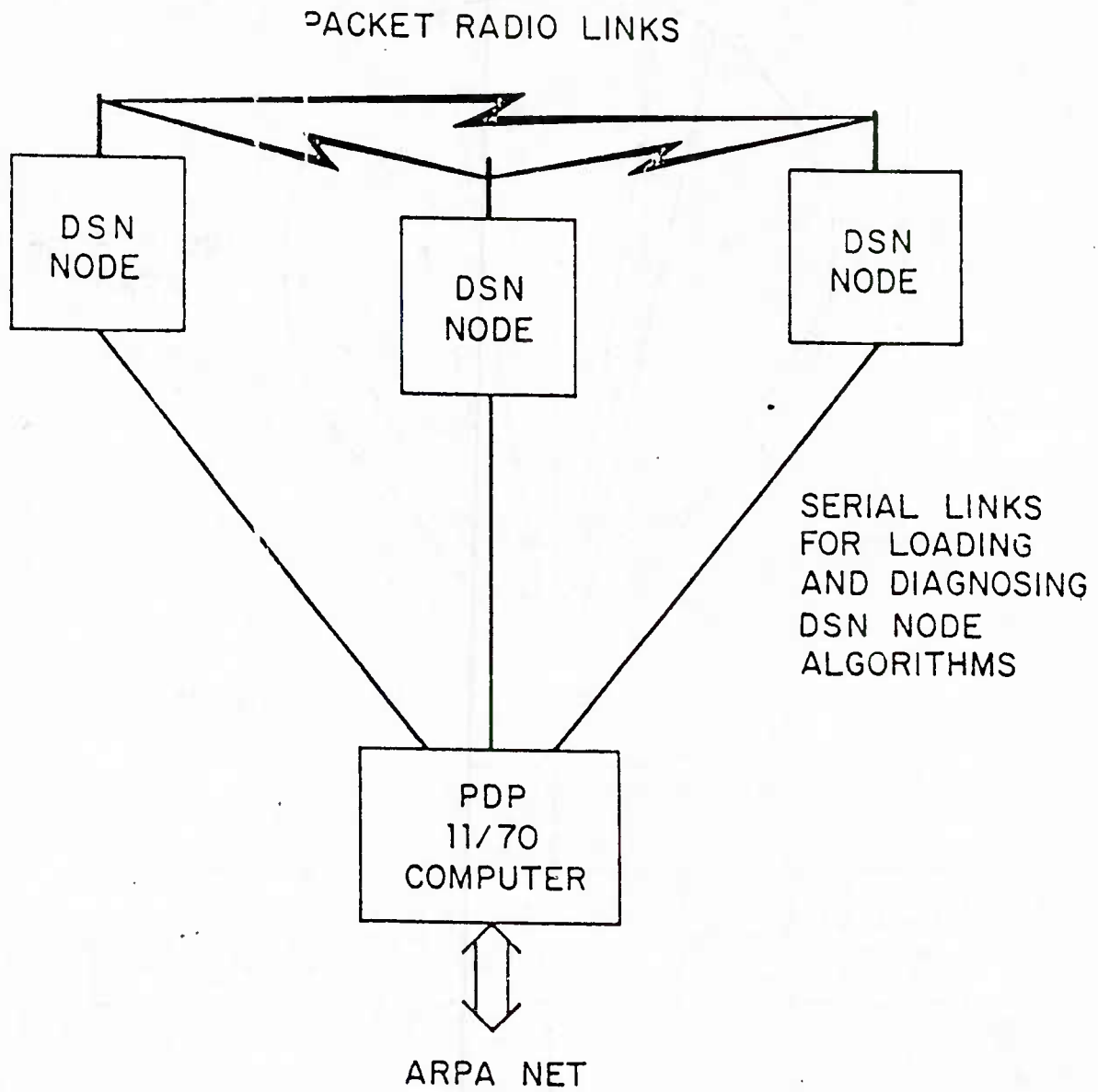
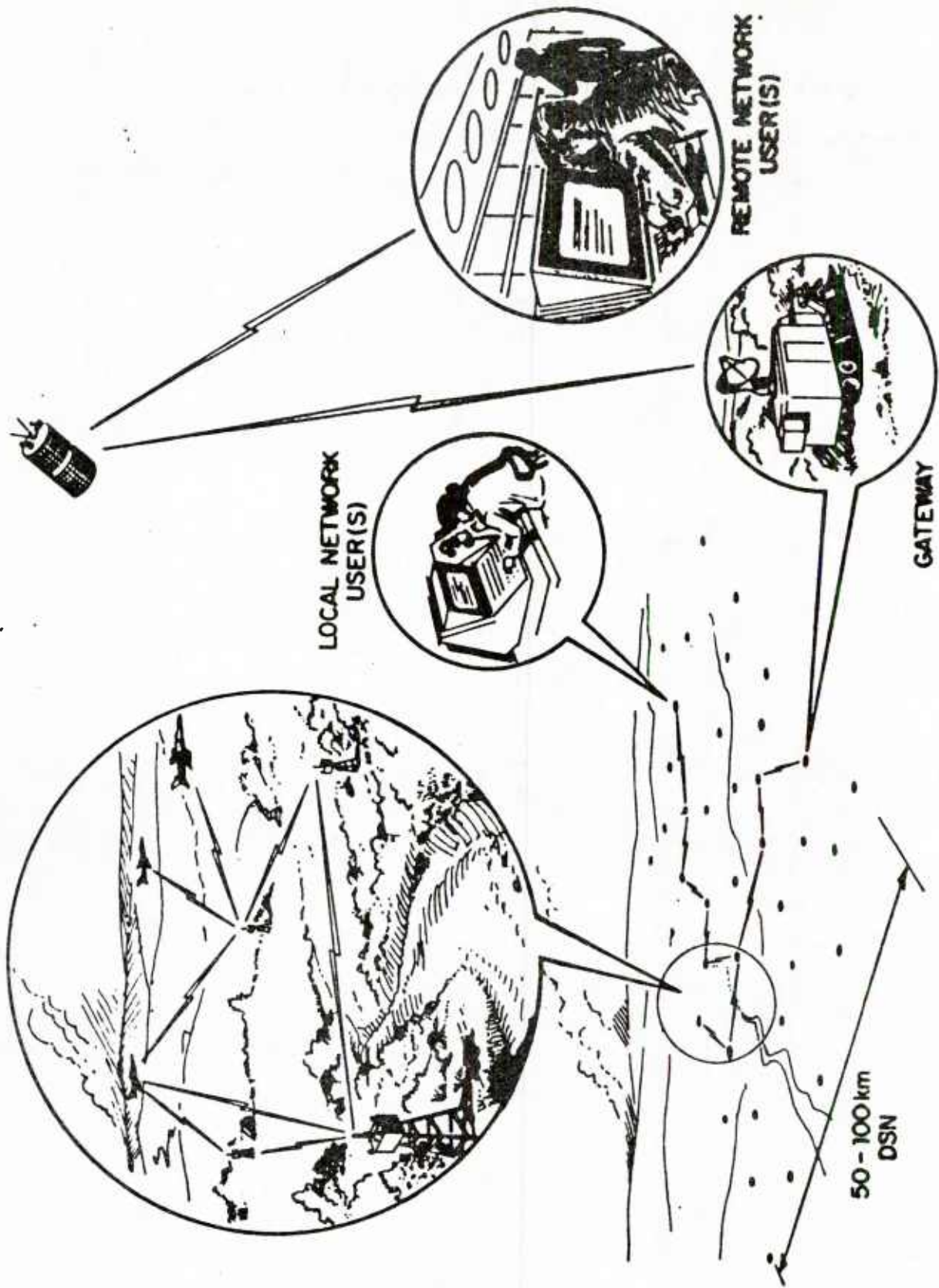

FIGURE 8.

Following are vignettes to be used to expand upon the preceding main text but which are not referenced in the text.



DISTRIBUTED SENSOR NETWORK LOW-LEVEL AIR SURVEILLANCE

LOW FLYING AIRCRAFT SENSOR OPTIONS

LONG RANGE RADAR

SHORT RANGE RADAR

SPECIAL MINI RADARS

MICROPHONES

IR

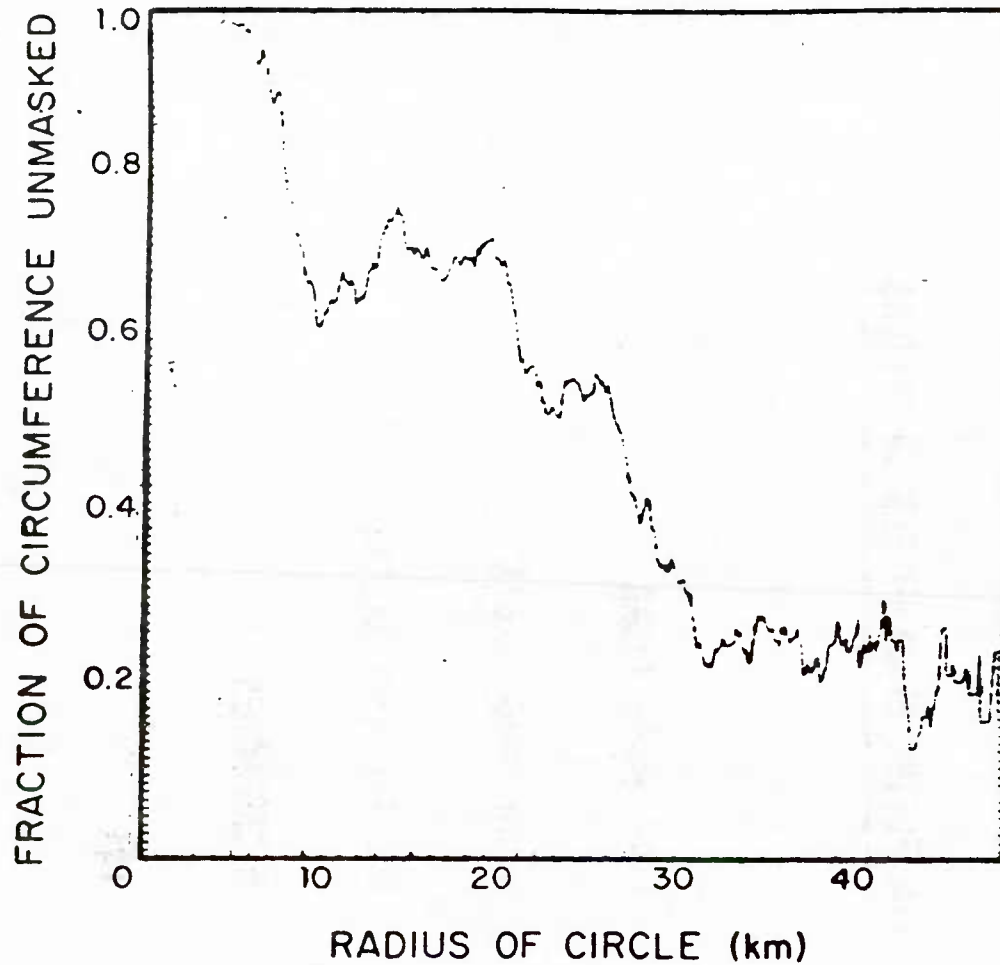

KATAHDIN HILL SITE
MISSILE ALTITUDE - 30m
ANTENNA HEIGHT - 30m
EQUIVALENT EARTH RADIUS - $\frac{4}{3} R_E$

LINE-OF-SIGHT RADAR COVERAGE STATISTICS

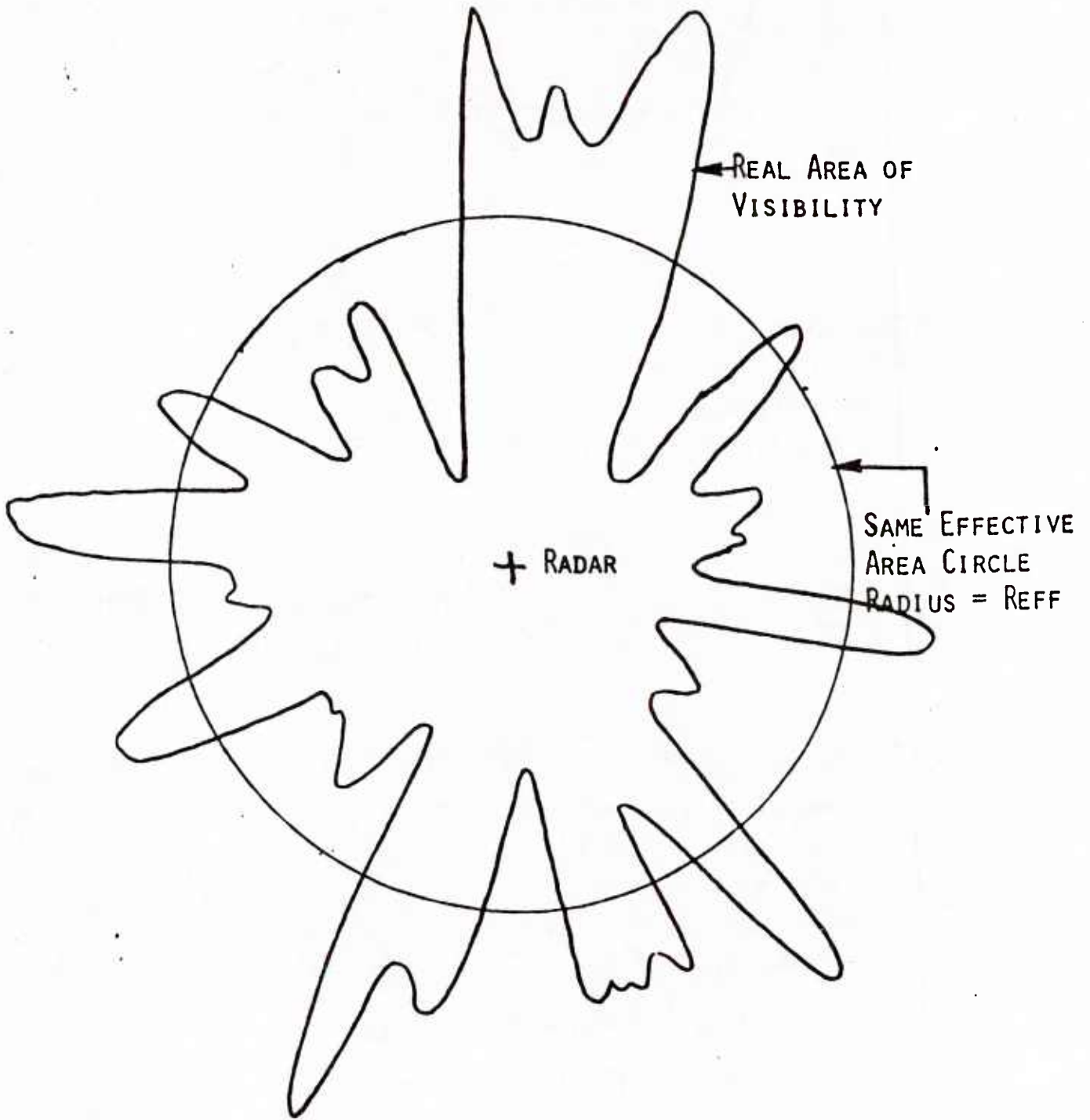

EFFECTIVE RANGE REFF.

EFFECTIVE RANGES OF RADARS

LAMBDA STUDY -

OPTIMAL SITING

SMOOTH TERRAIN
ROLLING HILLS ($\sigma=40\text{M}$)

19 KM
14 KM

CSA STUDY -

AREA COVERAGE WITH LOCAL
OPTIMIZATION

1. RADAR ANTENNA ABOVE VEGETATION

OPEN TERRAIN ($\sigma=30\text{ M}$)	4.1 KM
MOUNTAINS ($\sigma=116\text{ M}$)	2.3 KM

2. GROUND BASED RADAR

OPEN TERRAIN ($\sigma=30\text{ M}$)	0.8 KM
MOUNTAINS ($\sigma=116\text{ M}$)	1.5 KM

ACOUSTIC SENSORS

- RESULTS FROM INITIAL FIELD EXPERIMENTS
 - 10 TO 20 km DETECTION RANGES
 - AZIMUTH MEASUREMENT USING 5 METER MICROPHONE ARRAY
 - OVER ENTIRE DETECTION RANGE
 - RESOLUTION $< 5^\circ$
 - LIMITED ELEVATION ANGLE CAPABILITY
 - SOME POTENTIAL FOR NOISY OPERATION INDICATED
 - SPECTRAL DISCRIMINATION
 - SPATIAL DISCRIMINATION

CIRCUIT DESIGN PARAMETERS

<u>PARAMETERS</u>	<u>VALUES ANALYSED</u>
NODE LOCATIONS	REG. 10 KM HEX GRID
NODE FUNCTIONALITY	.1 - 1.0 (PROBABILITY)
LINK FUNCTIONALITY PROBABILITY	
10 KM	.7
17.3 KM	.5
>17.3 KM	0
RECEPTION SUCCESS PROBABILITY	.7
# OF RETRANSMITS	1 - 6
DELAY	0 - .25 SECOND
ROUTING ALGORITHM	"AREAS OF INTEREST" (30 KM)
CIRCUIT	PATTERENED ROUND-ROBIN RANDOM ROUND-ROBIN
MESSAGE PATH LENGTH	10, 17.3, 20, 27 KM

SENSOR COMMUNICATIONS

SENSOR COMMUNICATIONS

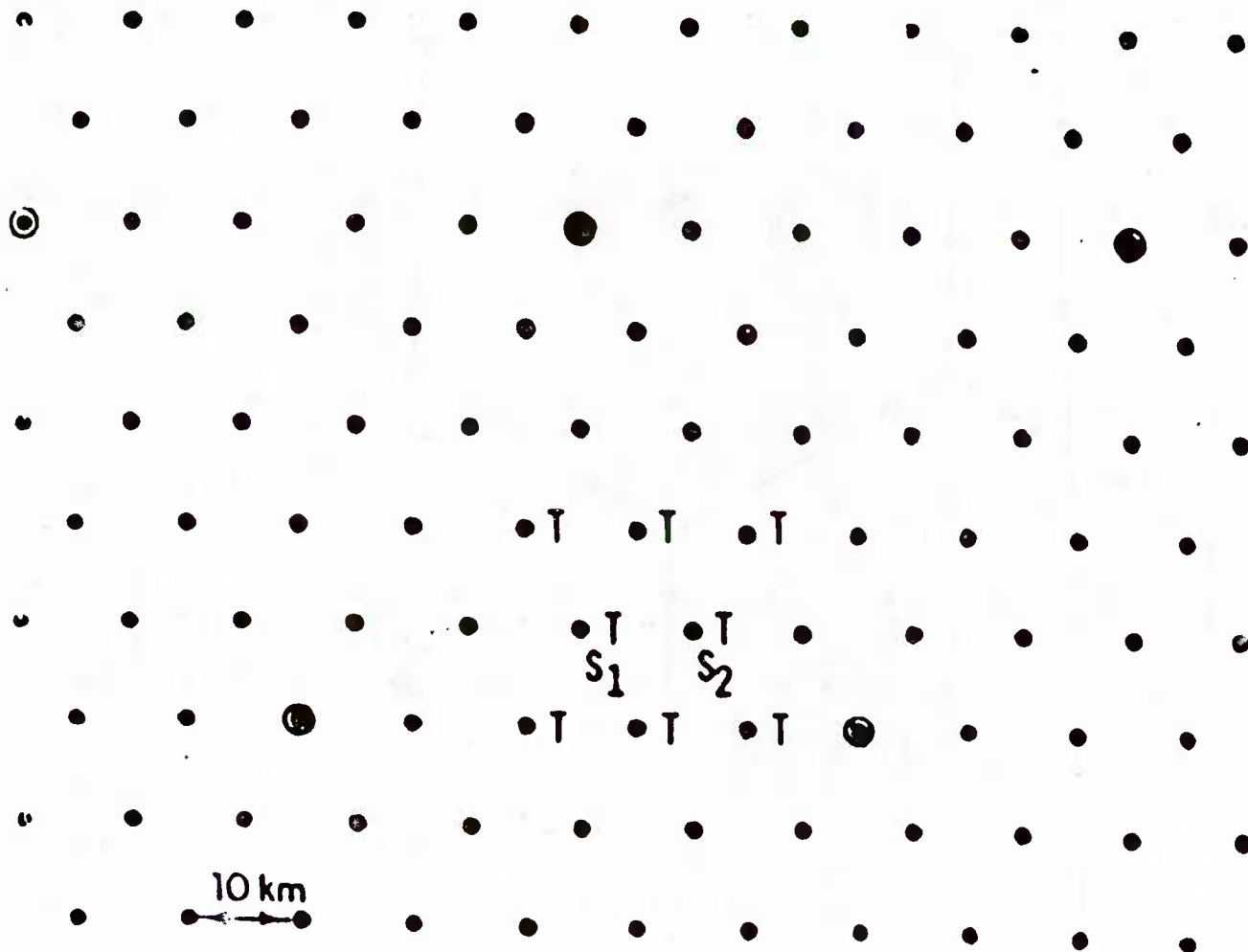

DEFECTS (2 NODE)

- FUNCTIONALITY (AT LEAST ONE OF THE PAIR DOES NOT FUNCTION)
- COMMUNICATIONS (BOTH NODES EXIST BUT NO NODES ARE TRACKING)

REPORT CIRCUIT COMMUNICATIONS

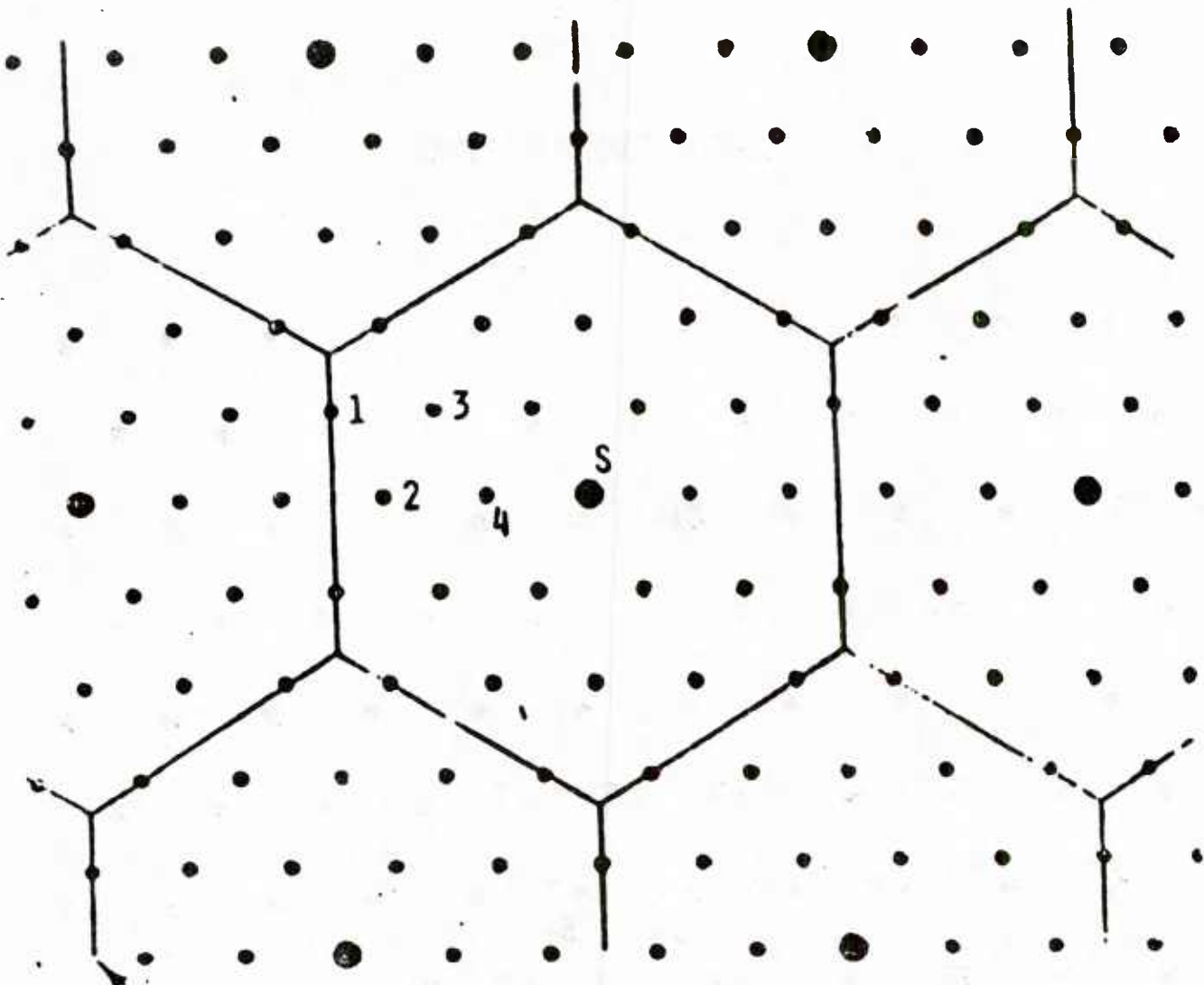

TYPES OF POSSIBLE DEFECTS

- CONNECTION \equiv NO COMMUNICATION PATH EXISTS BETWEEN SOURCE AND DESTINATION.
- COMMUNICATION \equiv NO CONNECTION DEFECT OCCURS BUT,
PROB (MSG + DESTINATION IN $\leq S$ SECONDS) $< P$
($P = .99$ OR $.9$)

LEAST S WITH PROBABILITY OF DEFECT $\leq .02$
 REPORT COMMUNICATIONS DEFECTS

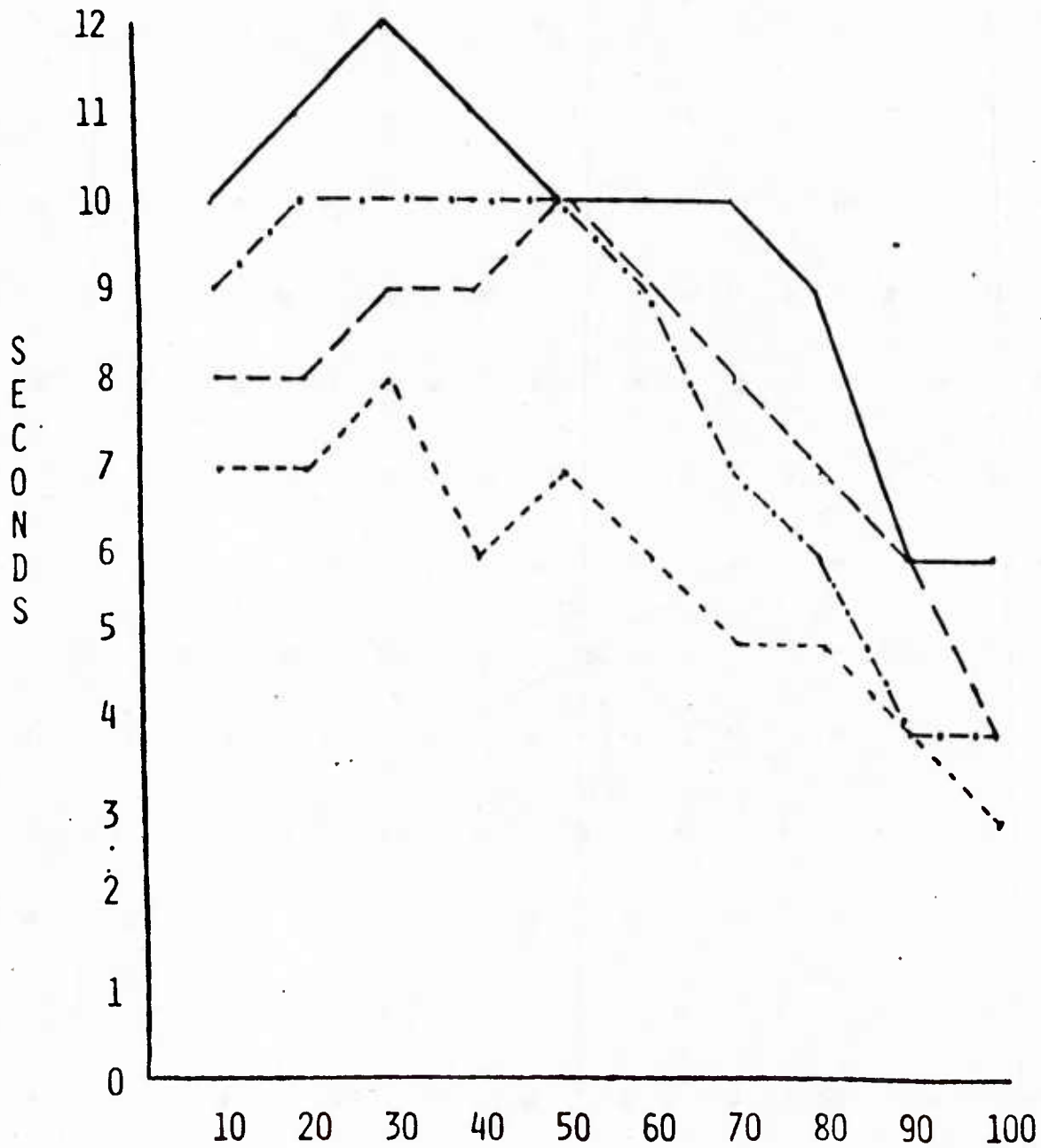

NODE FUNCTIONALITY (%)

- NODE 1 (27 KM) 250 MSEC DELAY
- NODE 2 (20 KM) P = .99
- .-.-.-. NODE 3 (17 KM) PATTERNED ROUND-ROBIN
- NODE 4 (10 KM) 6 RETRANSMITS

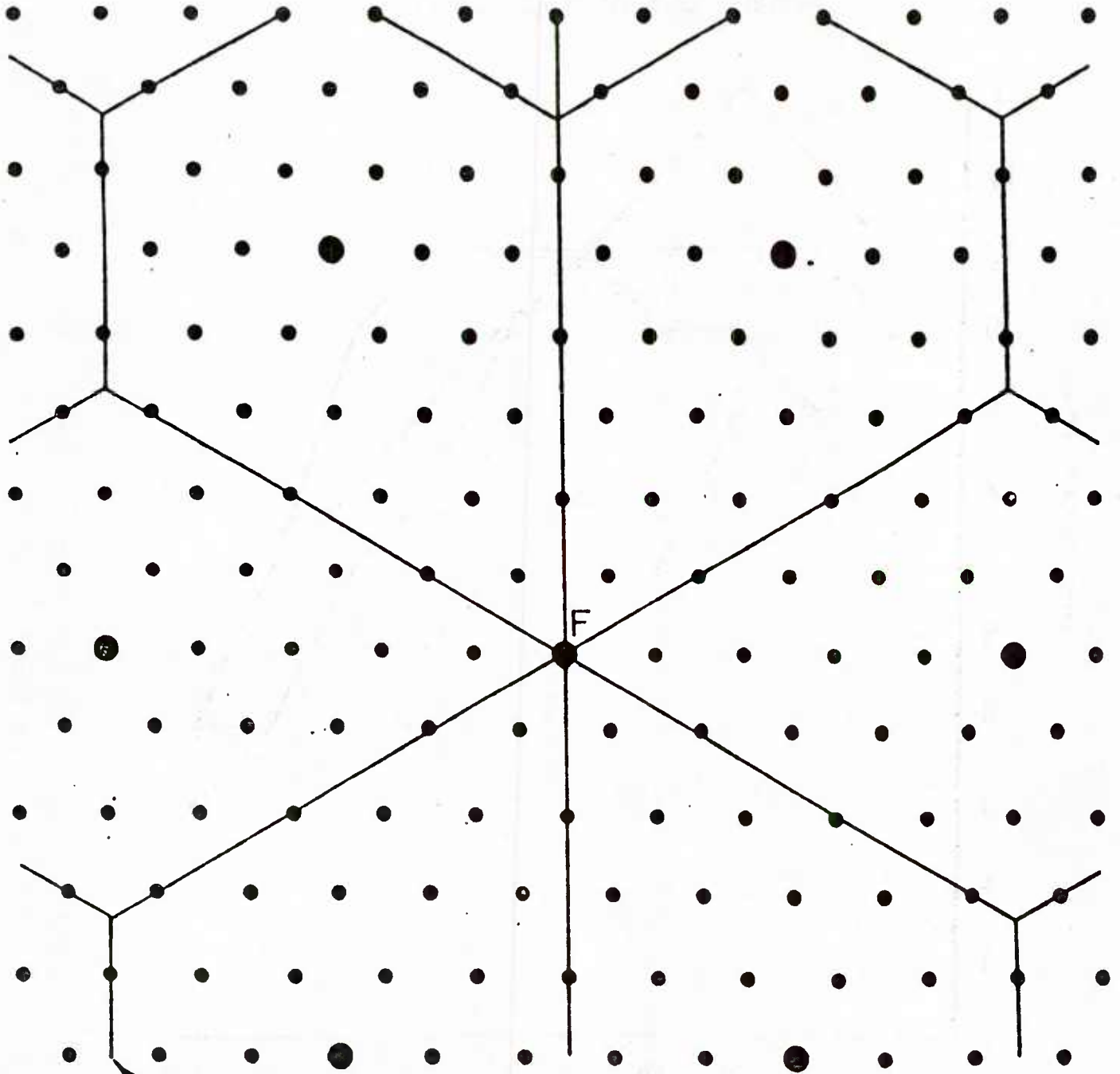

BOUNDARIES OF REDEFINED REPORTING SECTORS

- NODE
- SECTOR NODE
- ^F FAILED SECTOR NODE

STUDY OF SENSOR REDUNDANCY AND ADAPTIVE COMMUNICATIONS

S4

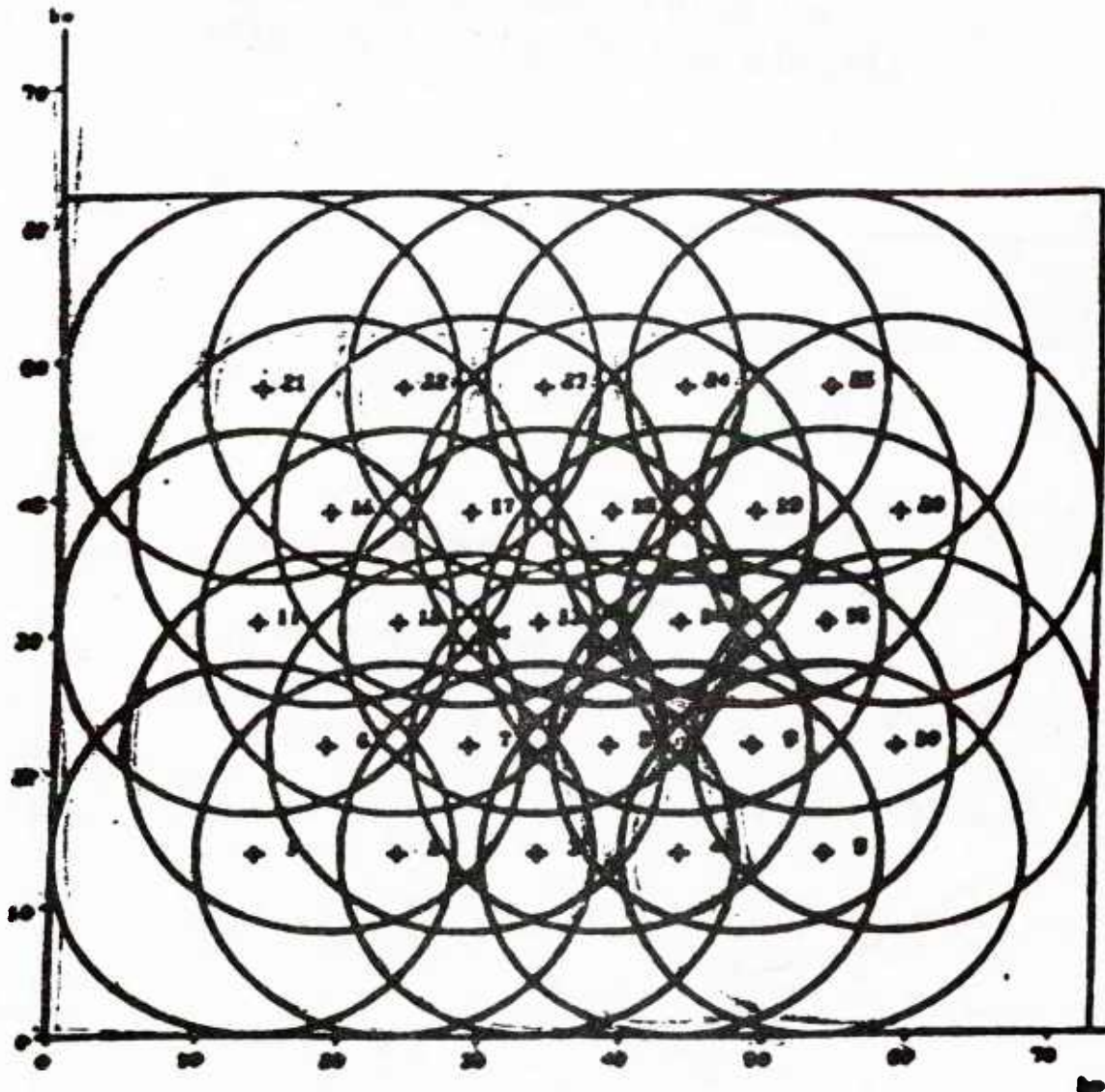

COVERAGE MAP FOR 25 NODE RADAR NETWORK
SPACING 10 KM RANGE 14 KM

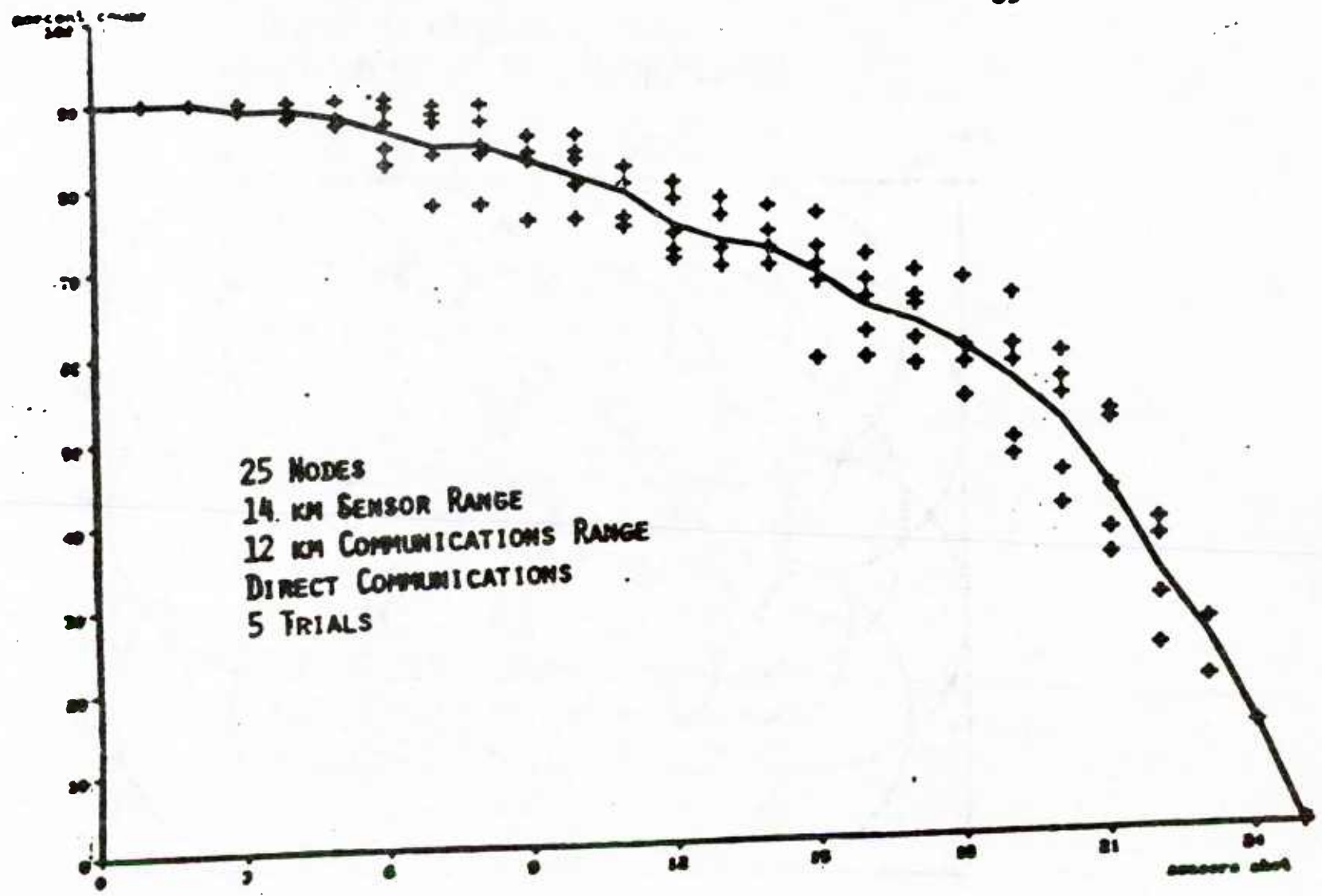

MONTE CARLO SIMULATION OF PERFORMANCE
DEGRADATION WITH NODE ELIMINATION
USING DIRECT COMMUNICATIONS

454

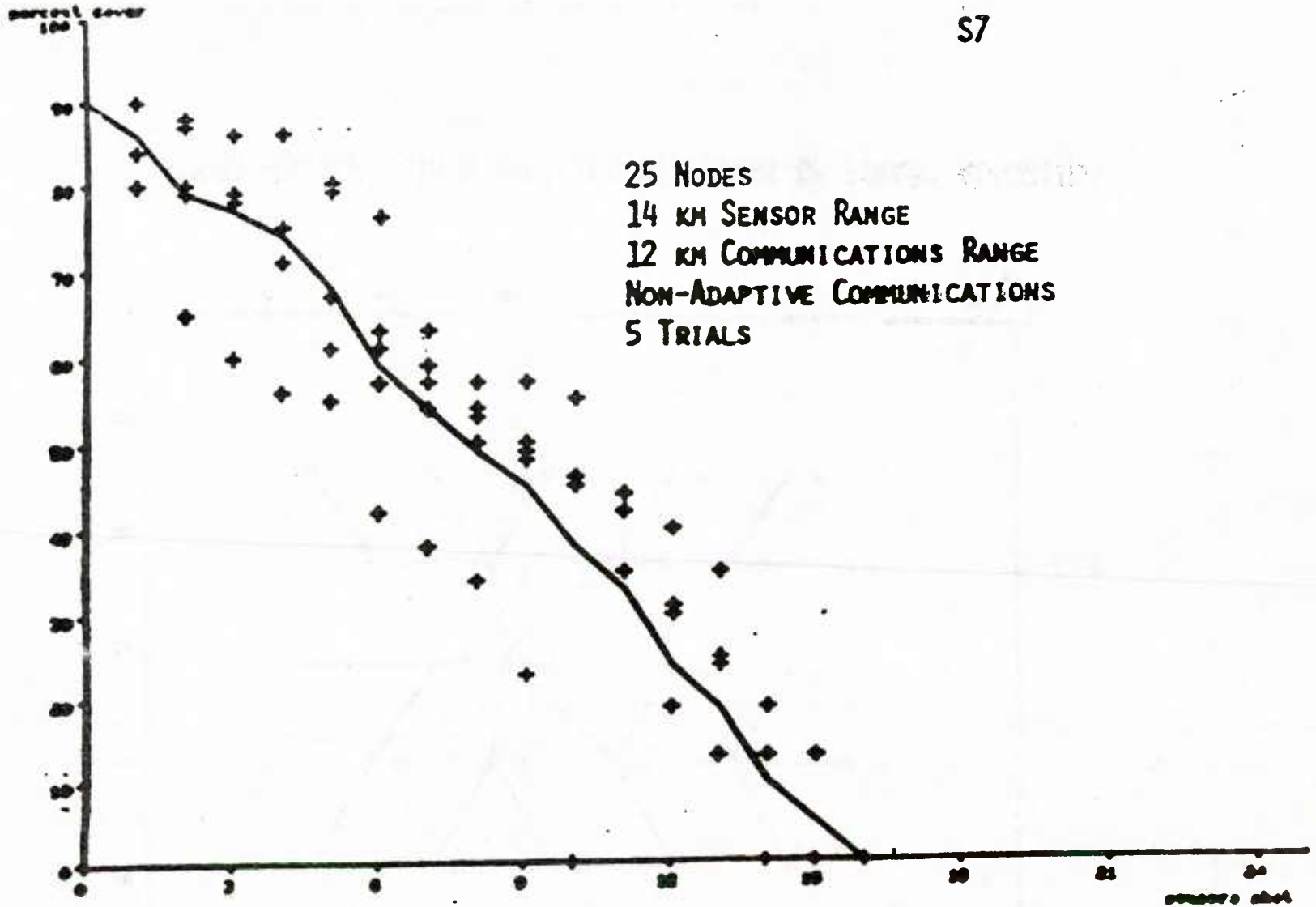

DEGRADATION IN EFFECTIVENESS WITH NODE ELIMINATION USING NON-ADAPTIVE COMMUNICATIONS

450

457

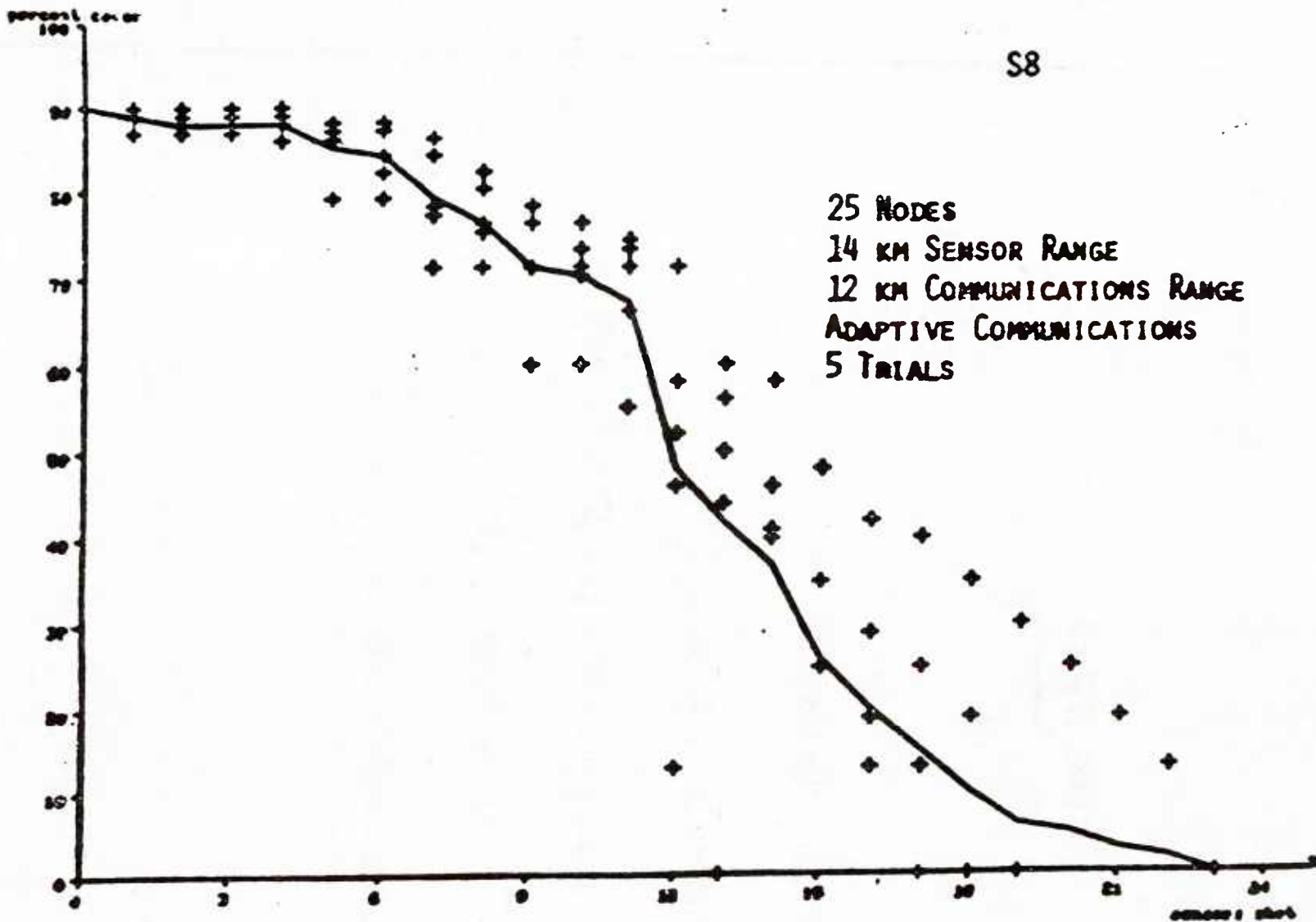

DEGRADATION IN EFFECTIVENESS OF DSM WITH NODE ELIMINATION USING
ADAPTIVE COMMUNICATIONS

SOFTWARE TESTBED

- SIMULATES DSN HARDWARE
- RUNS ON PDP 11/70 UNDER UNIX
- FOR DEVELOPING 3 NODE EXPERIMENT SOFTWARE
- FOR SIMULATING DSN'S TOO LARGE TO BUILD
- FOR PERFORMANCE STUDIES

SIM1B SIMULATOR

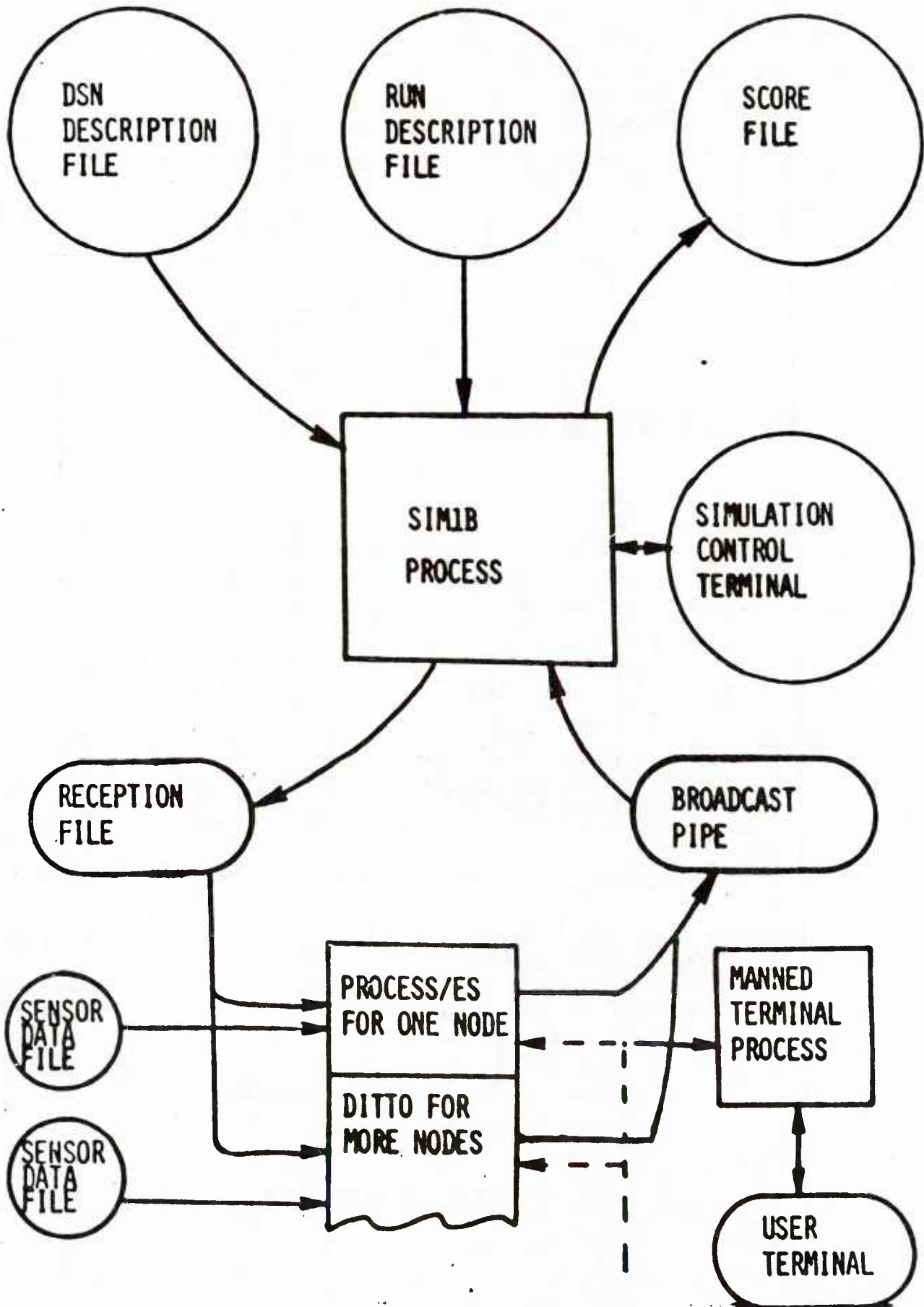

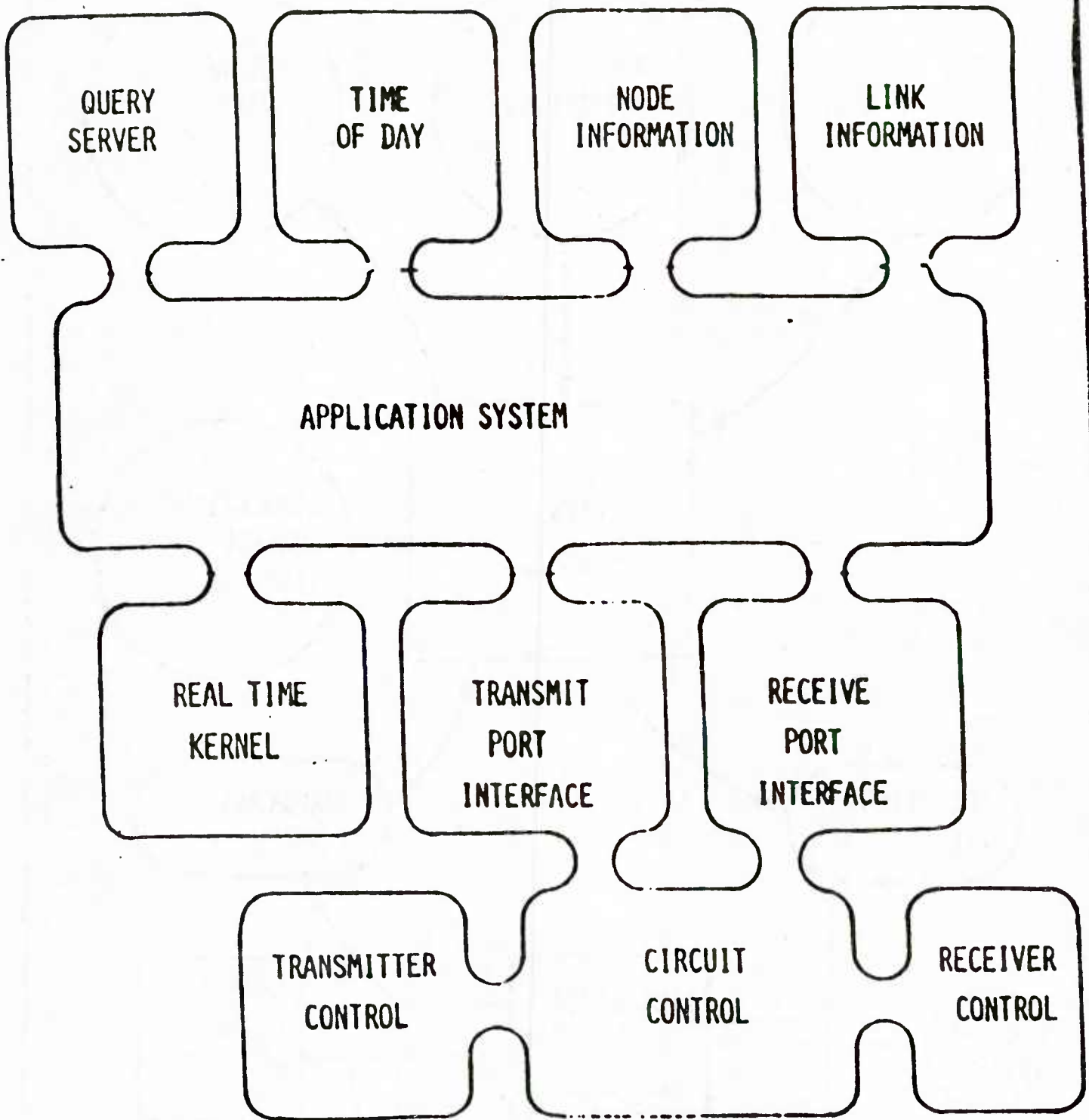

OVERALL DSN NODE SOFTWARE STRUCTURE

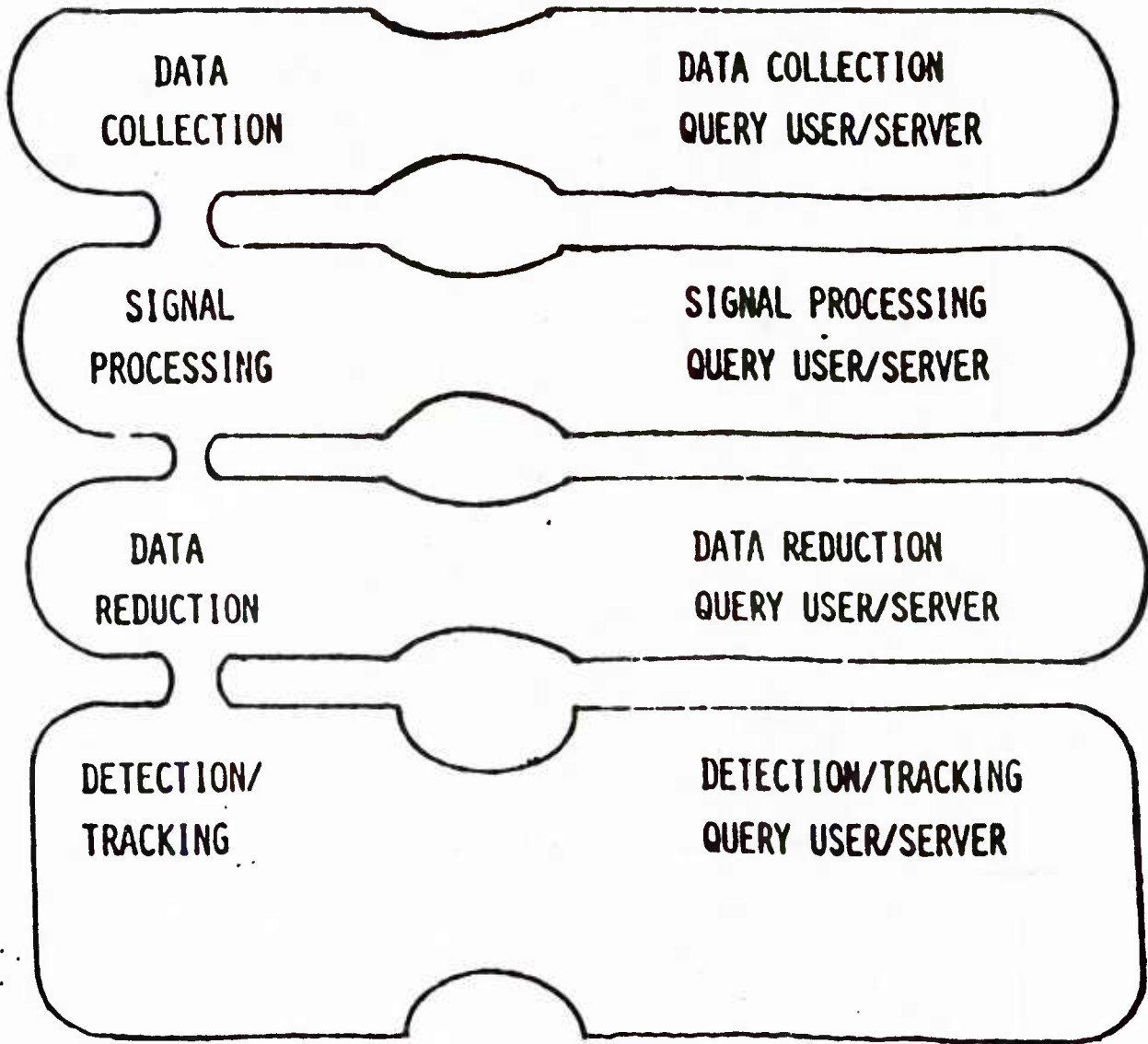

DSN NODE APPLICATION SOFTWARE STRUCTURE

THE STATE VARIABLES OF A COMMAND CONTROL SYSTEM

Joel S. Lawson
Technical Director
NAVELEX
Washington, DC 20360
(202) 692-8960

THE STATE VARIABLES OF A COMMAND CONTROL SYSTEM

There are many definitions of command control or command control systems in common usage, which is one reason why the subject is so difficult to discuss. Personally, I like to

Slide 1. define command control as the process by which a properly designated commander exercises authority and direction over assigned forces in the accomplishment of his mission.

And, in general terms, we can state his mission, or the purpose of the command control process, as controlling the environment in which the commander and his forces are embedded.

Slide 2. And that control generally is used to either maintain the status quo of the environment or to change it to some other, more desirable state. The ultimate aim of a command control process is then to control the changes of state of an environment.

Now, what are the elements that go to make up a command control system which can carry out or execute this process?

Slide 3. This slide shows you the conventional list with a couple of important additions.

First of all, the commander can't control the environment himself. His control derives from a real or threatened delivery of ordnance onto a target. So his forces must be considered as part of his command control system because they provide the means for him to control the environment around him.

And for the command control process or system to function, there must be a commander. There has to be a single will directing, at least in a macro sense, the activities of the forces. Besides--

COMMAND CONTROL IS THE PROCESS BY WHICH A PROPERLY
DESIGNATED COMMANDER EXERCISES AUTHORITY AND DIRECTION
OVER ASSIGNED FORCES IN THE ACCOMPLISHMENT OF HIS MISSION.

464

THE PURPOSE OF THE COMMAND CONTROL PROCESS
IS TO EITHER MAINTAIN OR CHANGE THE
EQUILIBRIUM STATE OF THE ENVIRONMENT,
AS DETERMINED BY A HIGHER AUTHORITY.

465

COMPONENTS OF A C² SYSTEM

SENSORS

COMMUNICATIONS

DATA PROCESSING

INFORMATION MANAGEMENT

DECISION AIDS

FORCES TO COMMAND

A COMMANDER

463

all too often we forget the commander designing things to please his staff, not to help him do his job. His staff is really only there to help him--to amplify his abilities to keep up with what's going on, and to watch out for conflicts between his own forces. (I'll come back to this point later on.)

Now what does the commander need to know about the environment in order to exercise control over it? Basically, he needs to know what state it's in now, and what state he'd like it to be in, so he knows which way to push it. And in a military--particularly naval--setting, the state of the environment

Slide 4. can best be described by the nature, identity, status and location of the "objects" or "things" in that environment.

This is the basic information that the commander needs. There are other things which might be nice to know, or even helpful to know, but these are fundamental to making the process work. And as you can easily see, these things can all be pretty well

Slide 5. represented by some kind of symbol on a map. So this leads us to what I consider the basic engineering problem in the command control world--producing an up-to-date geographic display of the location of "things" and, of course, their identity and status. And, of course, the reason for wanting a map-like display is that it is the spacial relationship of things that is the important parameter. And I might note that we'll see this emphasis on spacial relationship, and its time derivative, velocity, show up over and over again in our discussion of the C^2 process and the variables that affect it.

BASIC C² INFORMATION REQUIREMENTS

LOCATION OF THINGS

WHAT KIND OF THINGS

IDENTITY OF THINGS

STATUS OF THINGS

463

THE CENTRAL PROBLEM OF COMMAND CONTROL
IS PRODUCING AN UP-TO-DATE GEOGRAPHIC
DISPLAY OF THE LOCATION OF "THINGS."

463

Slide 6. Of course, this leads to the question of how "good" the geoplots has to be. I am inclined to oversimplify the requirements and state them as one mile and one minute in the local area and 10 miles and 10 minutes on a global basis.

If you take a reasonable missile and you know where the target is to within a mile and you're only a minute late, you have a pretty good chance of hitting it if the missile's not too stupid. And at the Presidential level, 10 miles in 10 minutes is probably enough unless it's a real crisis in which case you might want a hot line down to the one mile and one minute level. But those parameters don't differ by an order of magnitude; so we might as well treat it as one problem. There is the command control problem and if your design can't deal with an order of magnitude in scale, you've got the wrong system. So how big would the problem be if we tried to take care of everything in the world? It turns out there aren't very many things that are of naval interest. And one interesting point is that this is the whole Navy world. The

Slide 7. Army or the Marines face a very different problem because their targets are different. They have to deal with that number of objects on a not-very-large battlefield because their "objects" turn out to be individual radios or tanks or field pieces. In the Navy, these things are aggregated into one hull so that we have a smaller number of discrete objects with which to deal. So perhaps understanding and solving the Navy's command control problem will be much easier than solving the other Services'.

GEO-DISPLAY REQUIREMENTS

1. LOCATION AND IDENTITY OF ALL OBJECTS
2. 1 MILE AND 1 MINUTE IN LOCAL AREAS
3. 10 MILES AND 10 MINUTES WORLDWIDE

1. HOW MANY OBJECTS ARE THERE?

12,500 NAVAL VESSELS

62,000 MERCHANTS

2,500 MILITARY AND CIVIL AIRCRAFT

~ 80,000 OBJECTS

472

Now, what do we need to know about those 80,000 objects?

Slide 8. This slide makes the point that it really doesn't take very many bits of information to reduce your uncertainty about what something is where it is. And this data really doesn't change. Ships get launched and occasionally get sold and the names changed;

Slide 9. but these data are constants that go with the object. On the other hand, there are about an equal number of bits required to describe those things about an object of military interest which do, in fact, change. Now if you know that much about what some blip on a radar scope is, you really know enough--assuming that you know whether you're at war or peace--to know whether you want to sink it or not. There are other things you might like to know. But this 400 bits worth of information is really what's crucial. So we see that a few million bits of disc file is enough to contain all the data about everything in the world that the Navy cares about. And you could update an entry in the file with a report of a couple hundred bits. So keeping an up-to-date display for all the commanders in the world, from the White House down to a ship captain, would just about fit in a couple of voice bandwidths.

MODEL OF A C² SYSTEM

Now, having discussed the general nature of the command control process, let's see if we can develop some sort of model, which will let us investigate some of the variables which influence the system or the process. In keeping with our previous discussion, a convenient model of a command control process can be derived by

STATIC DATA

NUMERICAL RANGE

NO. OF BITS

FILE ENTRY NUMBER	80,000	17
NATIONALITY (OWNER)	150	8
NATIONALITY (FLAG)	150	8
TYPE	30	5
CLASS	200	8
NAME	12 CHARACTERS	96
RF SIGNATURE	1,000	10
ACCOUSTIC SIGNATURE	1,000	10
STATUS	500	9
PAGE NUMBER IN JANES	650	10

181

474

<u>DYNAMIC DATA</u>	<u>NUMERICAL RANGE</u>	<u>NO. OF BITS</u>
LATITUDE/LONGITUDE	86,400 (x2)	34
UNCERTAINTY	30 (x2)	10
ALTITUDE	132,000	17
UNCERTAINTY	30	5
COURSE/SPEED	360°/25,000	24
UNCERTAINTY	8 (x2)	6
IDENTITY OF OBSERVER	2,000	11
TIME OF OBSERVATION	43,200	16
CURRENT POSITION	86,400 (x2)	34
UNCERTAINTY	30 (x2)	10
DESTINATION	21,600 (x2)	28

195

considering it to be a cybernetic system which is attempting to control the environment around it. Such a system is shown in the next slide. Basically, the process starts with a sensing of the environment. This is followed by a comparison of the resulting perception of the environment with some "desired state" of that environment, generally established by higher authority. Based on this comparison, decisions are made and actions initiated to bring the environment into closer conformance to the "desired state."

That is, we postulate that the purpose of a command control process is to either maintain or change the environment around it, and this is the simplest model which portrays that purpose.

Obviously this representation can be expanded upon, as shown here, to accommodate some of the additional complexities of a real C^2 process. The sensed data must be processed in some way to provide a perception of the environment. Data on the environment can be provided by external sources. Rules of engagement and policies or directives limit the decisions available to the commander. And, of course, he has to keep higher authority informed of what he is doing.

Now, in general, command control processes are apt to have areas of concern or responsibility which overlap, as shown here. This overlap imposes on their mutual superior the requirement that he avoid setting goals or desired states for his subordinates which put them in contention. (It is the superior's responsibility to see to it that his air defense people do not shoot down his own returning strike aircraft.) It will later appear that this is an important function of a C^2 system--the avoidance of contention

477

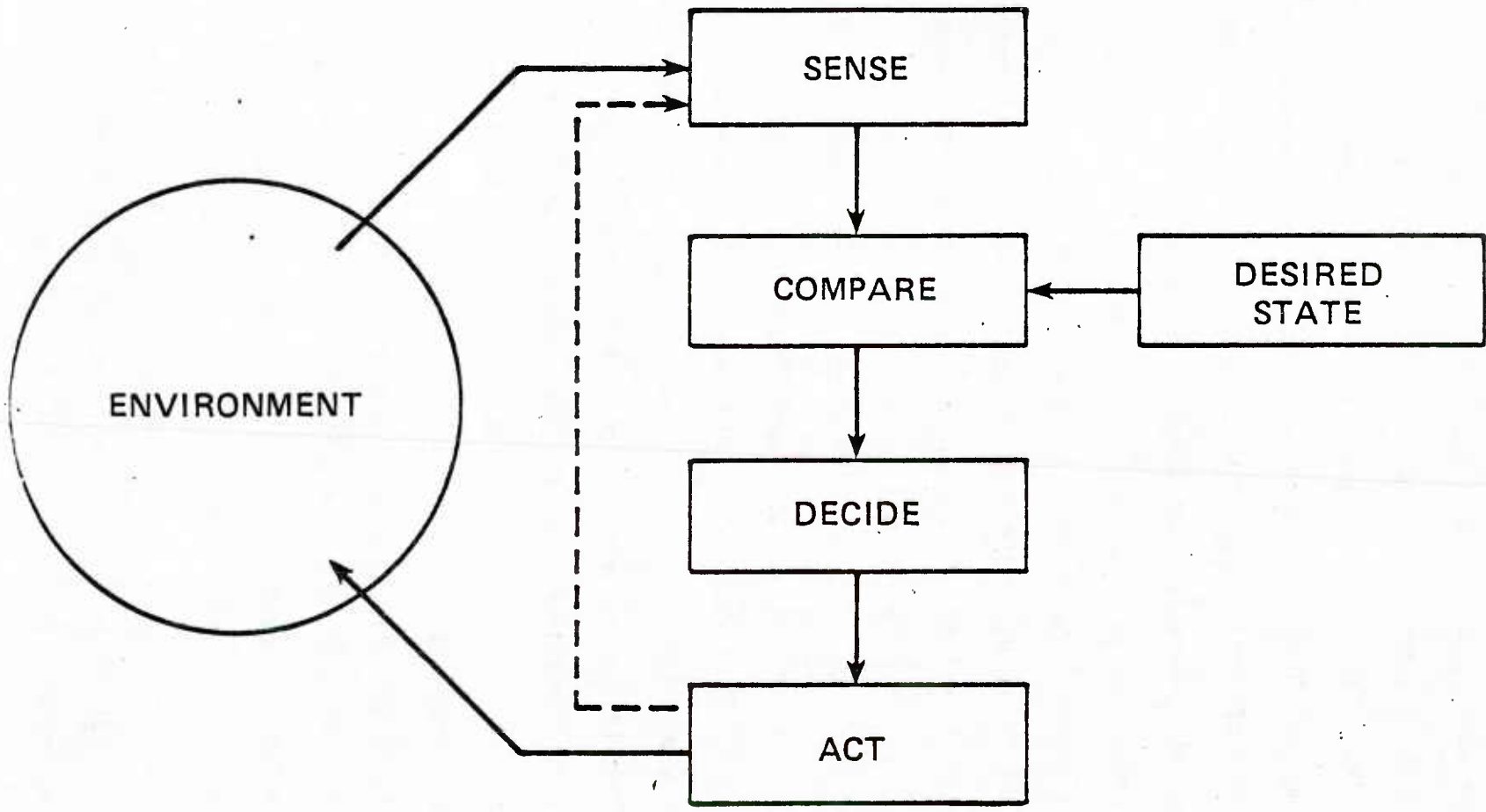

FIGURE 1. BASIC MODEL OF C² PROCESS

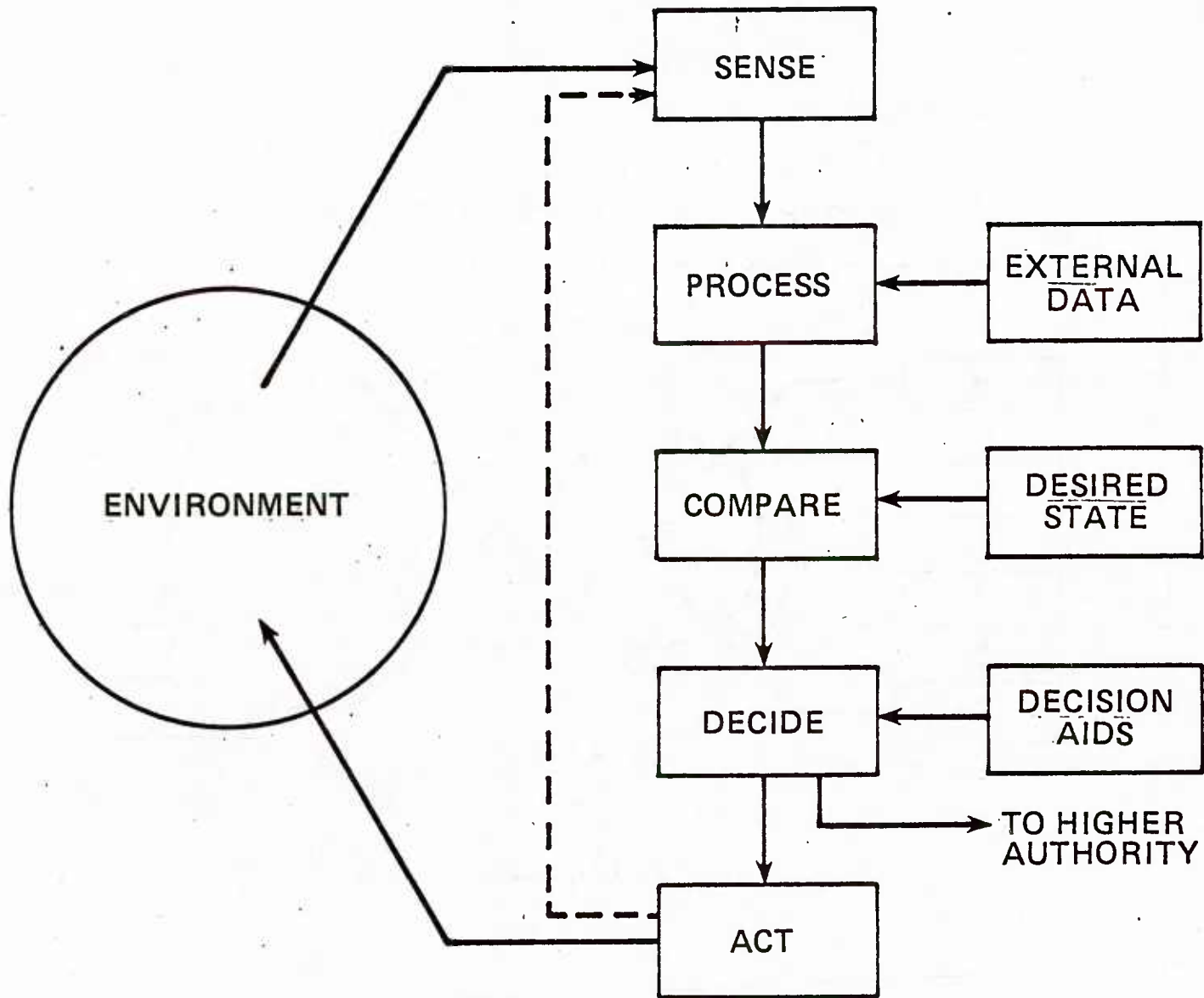

FIGURE 4. DETAILED MODEL OF C² PROCESS

473

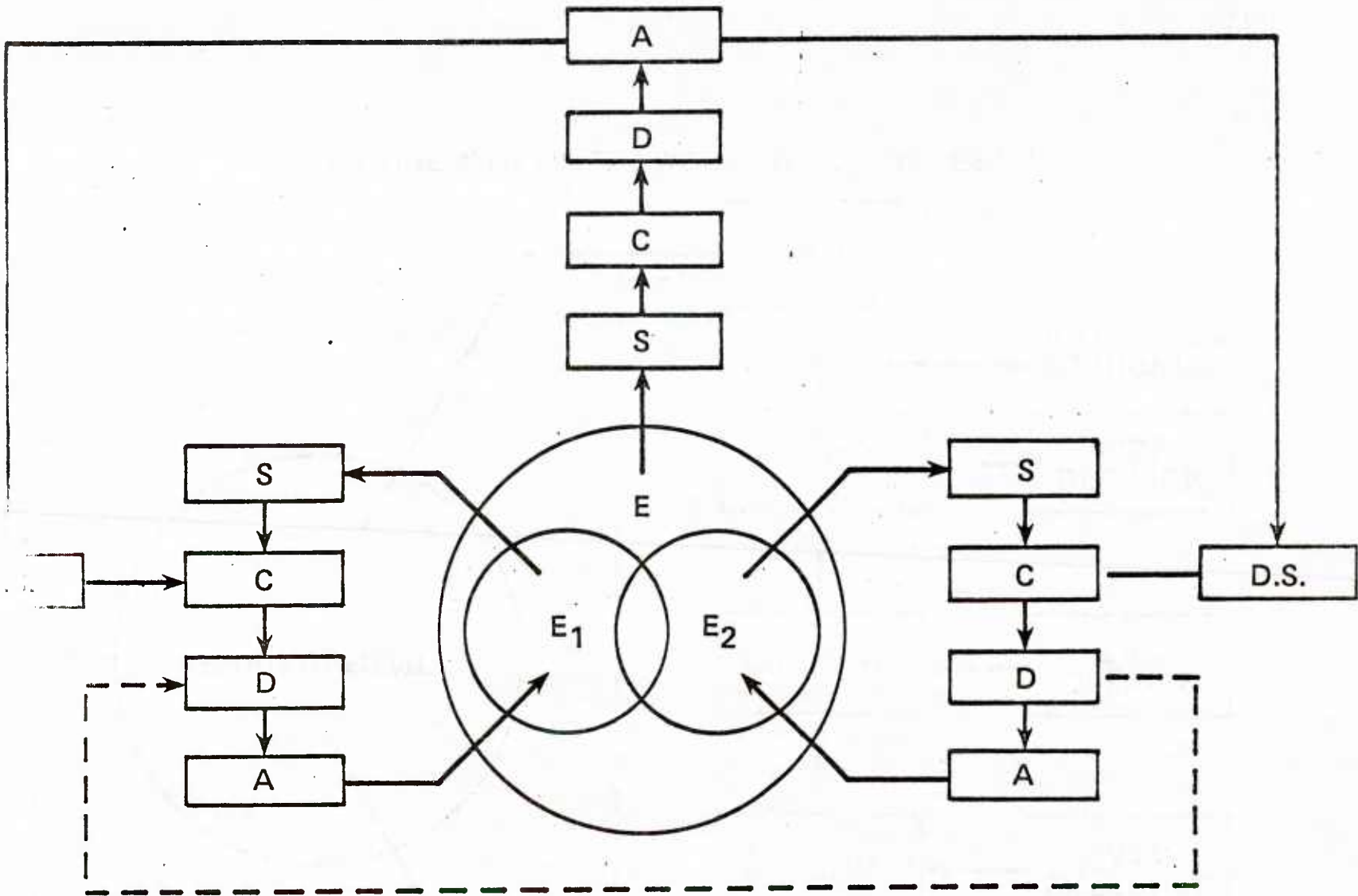

FIGURE 3. COORDINATION OF C² PROCESSES

between subordinates. This function is usually called coordination, which tends to hide its importance.

Finally, we note that what we usually think of as a "command control system" really has no direct effect on its environment. To model a process or system which can affect its environment, we must include the forces assigned to that commander. That is, the commander can only really control changes in his environment

Slide 13. by the threatened or actual delivery of ordnance on one or more targets. This slide shows such a model, in which we have included provision for interaction between the environment and the command control process through its assigned forces.

In this model, the C^2 process begins to take on some of the appearance of a thermodynamic system. The functions or activities in the boxes collectively serve to control the actions of the forces assigned in order to influence the state of the surrounding environment.

So, if we visualize the command control process as going on inside the circle labeled "own forces," then the curved arrows might represent the thermodynamic work done or heat absorbed from, the environment.

So, with this model in mind, let us go on and see if we can find some useful state variables or properties of our command control system.

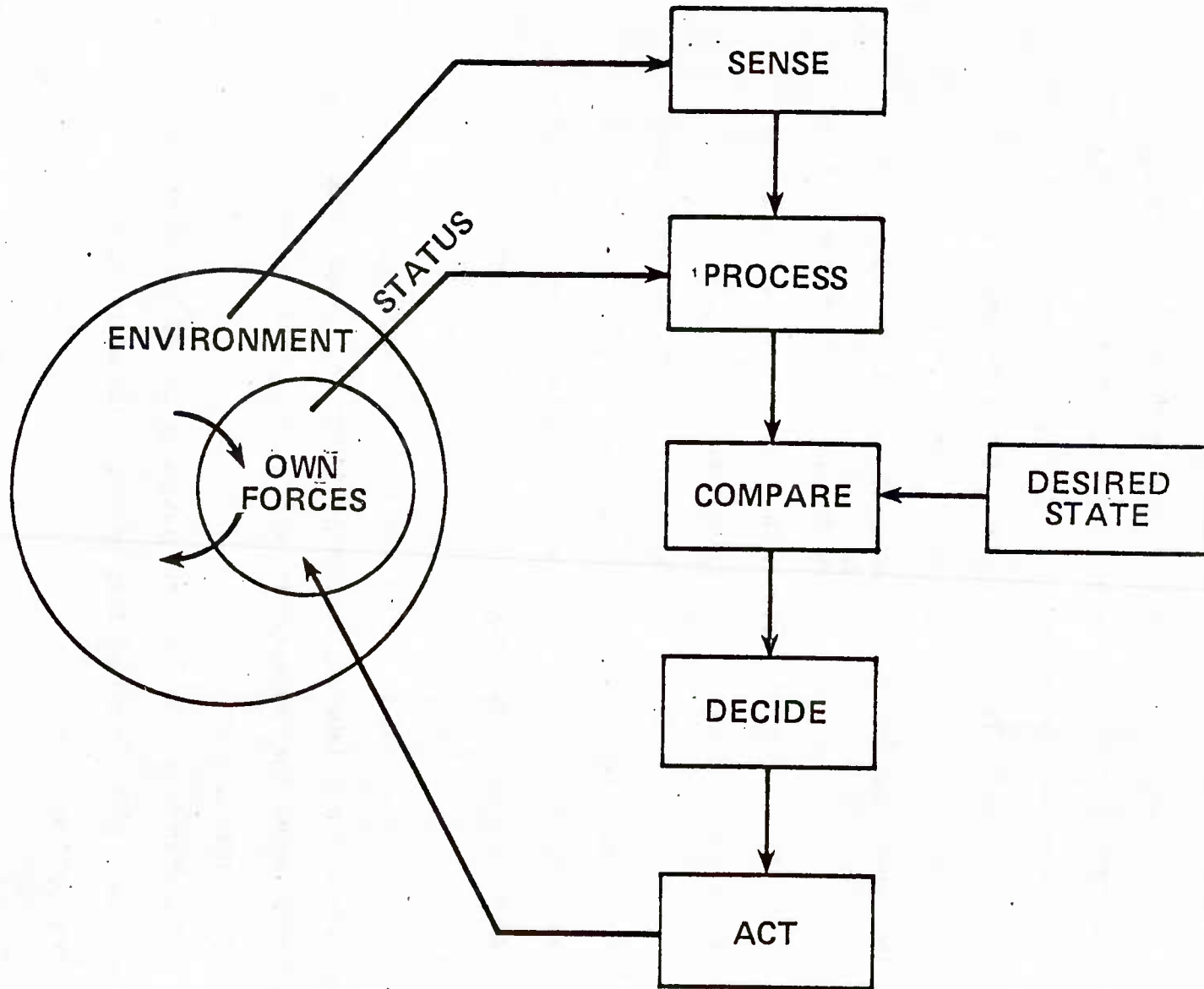

FIGURE 8. THERMODYNAMIC MODEL

AN "IDEAL GAS" ANALOGY

As a first attempt to identify some state variables, let's pursue an interesting, or at least amusing, analogy.

To do this, we note that it is obvious that the "military pressure" or influences which can be brought to bear is generally proportional to the number of forces involved. Similarly, if the tempo of operations is increased, the military pressure is increased. On the other hand, with fixed forces, if the volume within which they are to exert influence is increased, then the military pressure at any particular point must of necessity decrease.

These simple observations suggest that there is a military analogy to the "ideal gas law." In fact, we can write down just such a law:

Slide 14.

$$P_m V_r = k N T \quad (1)$$

where:

P_m = military pressure

V_r = volume to be pressured or controlled

N = number of forces

T = tempo of operations

k = arbitrary constant

This may not be very profound, but it does agree with observation. There remains, of course, the problem of settling on what units we use to measure our variables. Volume, of course, is length cubed.

$$P_M V_R = N K T$$

P_M = MILITARY PRESSURE

V_R = VOLUME TO BE CONTROLLED

N = NUMBER OF FORCES

T = "TEMPO OF OPERATIONS"

K = CONSTANT

Number of forces might be measured in terms of "equivalents."

Tempo of operations could be miles steamed or flown per unit time.

Slide 15. With these choices, we have

$$P_m(L^3) = k \cdot (\text{number of destroyers}) (L/T) \quad (2)$$

or, giving k the dimensions of time

$$P_m = (\text{number of destroyers})/L^2 \quad (3)$$

Equating military pressure or influence to the number of destroyers per square mile is not an unreasonable thing to do, even though it may not be a startling discovery, and in a similar way, we note that if pressure is measured as destroyers per square mile, then integrating over an area would give us the total force, measured in destroyers. And by analogy with physics we can define "work" or energy as force times distance. So our unit of work becomes "destroyer" miles.

And that is not an unreasonable definition of "military work." The number of miles that a task force or tank battalion advances is a useful way of describing the military work done.

This analogy may be more amusing than profound, but it does serve to point out four state variables which are important from the National Command Authority's point of view. Specifically, how much pressure or persuasion do you want to apply, over how large an area (or volume), how many forces are avoidable, and can they sustain a tempo of operations which will produce the desired equilibrium state?

$$V \sim L^3$$

$$N \sim \text{destroyer equivalents}''$$

$$T \sim \text{miles steamed} / t$$

$$K \sim t$$

$$\therefore P_m = (\text{no. of destroyers}) / L^2$$

$$\int_A P dA = \text{total forces}$$

$$\text{Work} = \text{destroyer} \cdot \text{miles}$$

It remains to be seen whether we can develop sensible coefficients of compressibility, or Hooke's Law constants, which apply to this system. In fact, there is no proof that these are really system properties in the sense that there are suitable relationships between the differentials of one with respect to another.

A PHASE SPACE ANALOGY

In a somewhat different analogy, we can consider our model of a command control process from the viewpoint of the commander who is embedded in the process.

His first concern, of course, must be the condition or status of his command control system, itself, as the term is conventionally used. That is, how well is he informed about the environment, can he communicate with his forces, and so on. Secondly, he is concerned with the status of his forces--are they adequately supplied with fuel and munitions and is their equipment in good working order? And finally, he is concerned with his environment--how large is it? what state is it in? and how different is it from the desired state set by higher authority?

Slide 16. This leads us to consider a three-dimensional "phase space" in which the command control process can be viewed as existing, as shown in the next slide. Interestingly enough, the Navy already has in common usage, terms which can be thought of as the names of regions along each of these coordinate axis. For instance, the

487

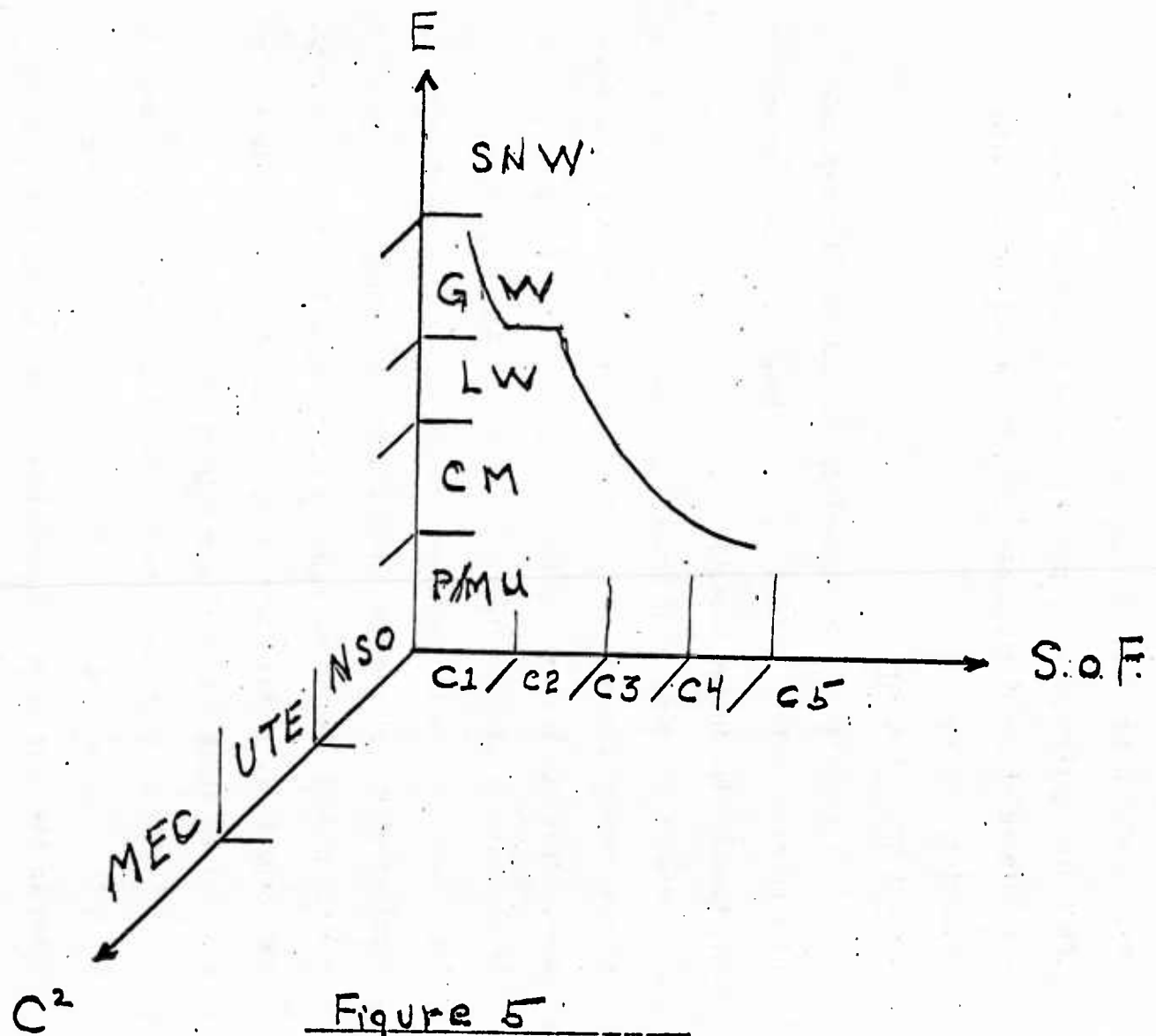

Figure 5

terms to describe Operations (NSO), Unimpaired Tactical Effectiveness (UTE), and Minimum Essential Communicatives (MEC) refer to three successively more degraded levels of communications system performance. C1 through C4 are common terms to describe the readiness of forces. And, the terms Political/Military Uncertainty (PMU), Crisis Management (CM), Limited War (LW), General War (GW), and Strategic Nuclear War (SNW) are commonly used to describe the geopolitical situation in the surrounding environment.

It is easy to draw an analogy between these conditions or states and the equivalent phases of a thermodynamic system such as solid, liquid, and vapor. And this analogy serves to remind us that the "equation of state" of our command control process may change significantly as we transition from one "phase" to another. In fact, there is some reason to believe that the transition between crisis management and limited war, or NSO and UTE, might put a greater strain on our command control process than the continuing conduct of operations wholly within any of the phases.

In fact, we can even sketch in a curve which might represent the acceptable behavior of our forces as a function of the geopolitical environment. In a cold war or PMU situation, an admiral might be willing to accept a large part of his forces in an unready, or C4 condition. As the situation deteriorates, he will demand a higher and higher readiness state. Then, with the outbreak of

general war, there is a discontinuity, and he would like to see that all his forces be C1, fully combat ready. Thus our curve might be viewed as the "operating characteristic of an admiral." As long as he is to the left of it, he's only moderately grumpy; but when he is to the right of it, oh my!

In an extension of this decomposition of the phase space of a command control system, we can again decompose each of these coordinate axis into three subcoordinates, and then repeat this process, apparently ad infinitum. In this slide we show such a decomposition carried to the third level.

Slide 17. There is one interesting point to be made from this breakdown. Even at this level, it is evident that we can describe the condition of our "C² system" in numbers or at most a few words. The condition of our forces may take a sentence or two; and the status of the geopolitical environment may take a paragraph or two for each component.

In addition, the commander more or less determines the status of his C² system locally, while the status of forces flows "up" to him from below. He, in turn, condenses it and passes it on up the chain of command. Much of the environmental information, on the other hand, flows "down" the chain of command, and his responsibility is to separate and amplify it and pass the appropriate parts to his subordinates.

So we are led to wonder if the total information input to a command center may not have a direct relation to the total information output. This would be an interesting subject for further research.

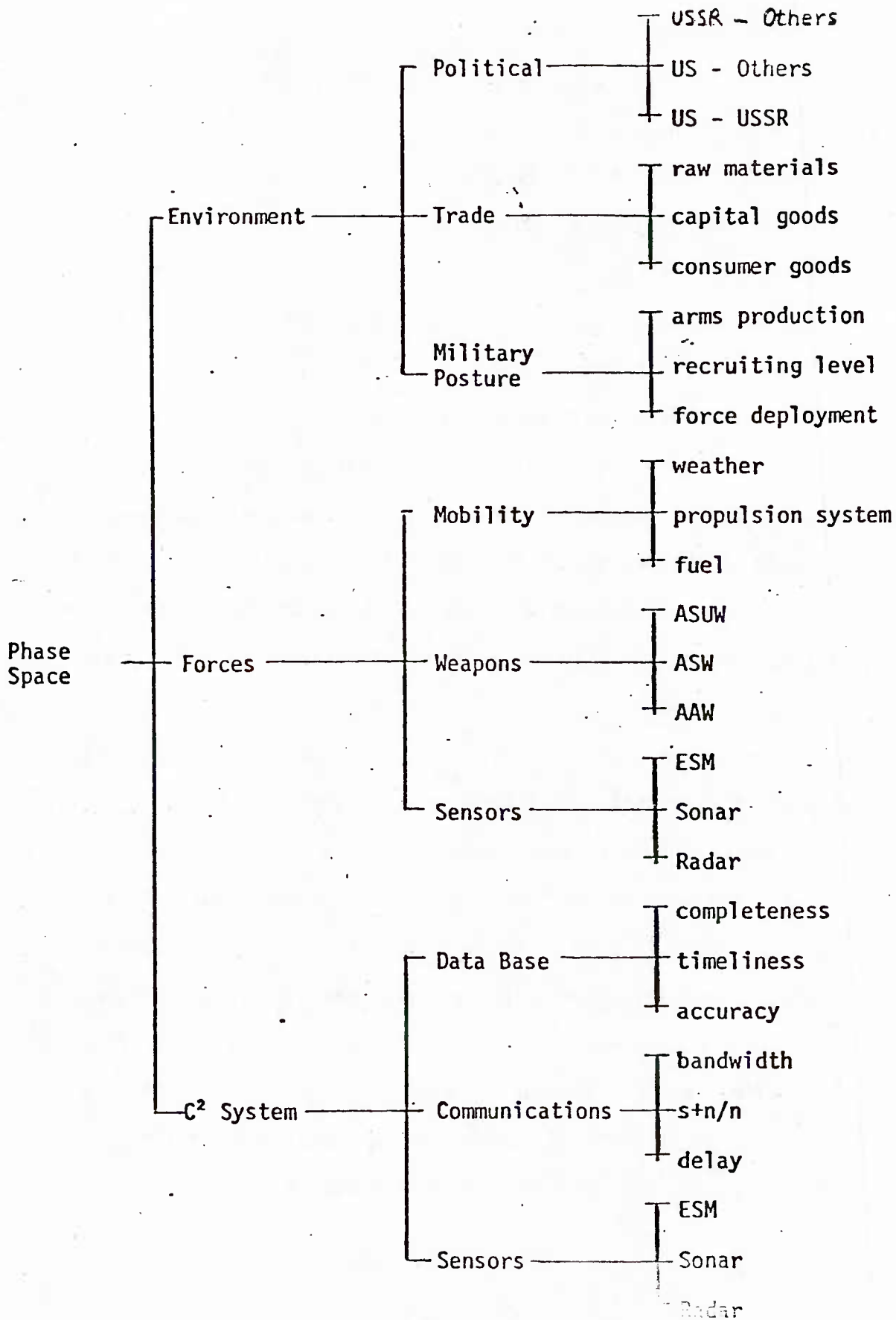

But, rather than pursue the line of inquiry, let us again shift our analogy, and examine another representation of a part of our command control process.

A COMMUNICATIONS SYSTEM ANALOGY

We have just seen that we can identify various sorts of information which our commander would like to have or which his command control process must be able to provide him. This leads us to consider the more local question of what information is critical to his activities and functions.

It has been argued elsewhere (1) that the most important element of the commander's information resources is a geographic display of the positions of "things" in his environment. That is, he must have an up-to-date representation of the spacial relationships of objects within his environment in order to effectively employ his forces.

Slide 18. Now, if we go back to figure 2, we can draw an analogy with Shannon's description of a communication system.

Our sensor becomes an encoder, sending us signals which represent a message about the state of the environment. This message, which in general has been selected by the environment, is in fact a possible choice from a Markov chain stochastic process. Given that a ship was at some position an hour ago, there are a limited number of places we can detect it now. And furthermore, if we had an estimate of its course and speed, some of the presently possible locations are more probable than others.

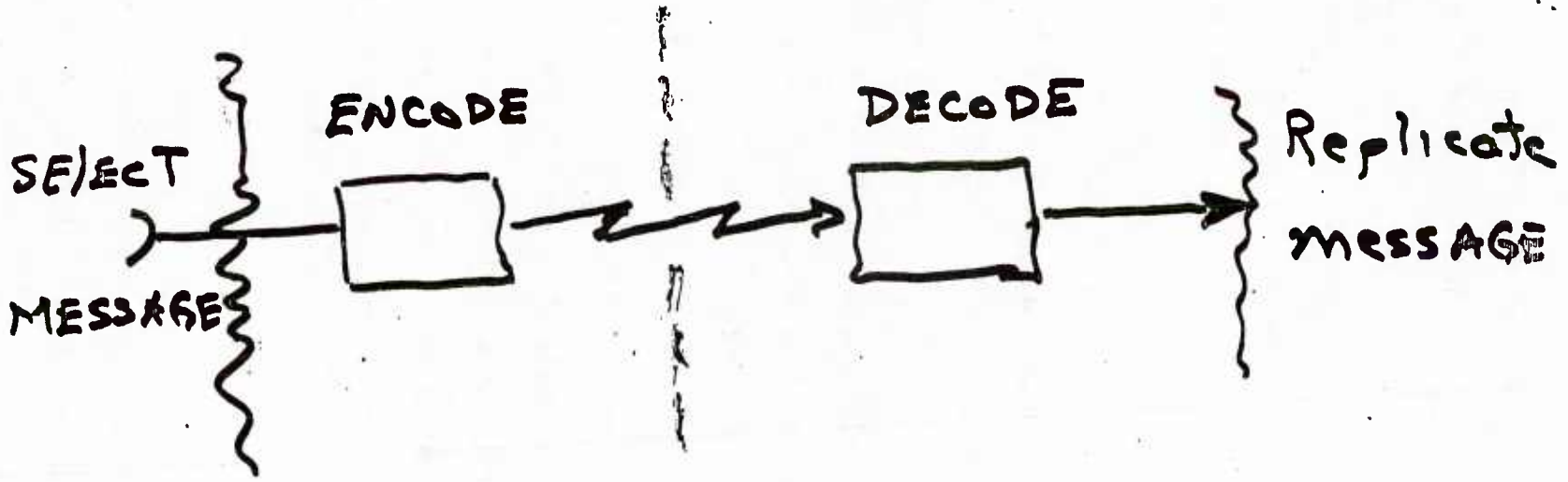
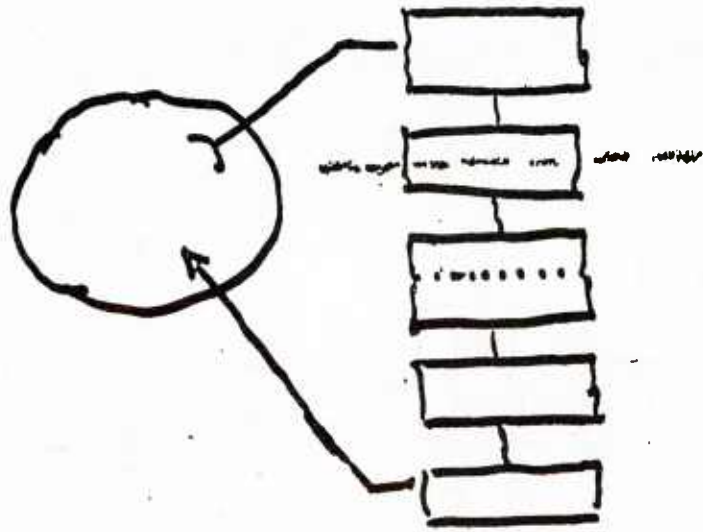

And it is a brief step from this realization to the recognition that, while the value of "information" is hard to quantify, its converse--the "reduction in uncertainty"--can easily be measured in bits. Knowing a particular ship is south of the equator and in west longitude is worth exactly two bits out of a possible 34 if we choose to divide the world into a quarter-mile grid.

And this, of course, brings us full circle; for in the next breath Shannon goes on to point out that in this sense, information is closely related to the thermodynamic property of entropy.

That is, entropy in the classical thermodynamic sense, mostly highly developed by Gibbs, is a measure of the randomness of a chemical system, and hence our uncertainty of the detailed structure of the system.

This, in turn, leads us to consider the entropy--or relative entropy--of our command control system.

While it is hard to see just where this concept fits into our thermodynamic model of a total C^2 process, there is one obvious application. Some targets have much more apparent randomness than others. Fishing vessels appear to be quite unconstrained in their motions than merchant ships--and in equal time intervals, aircraft can move into many more locations than can ships.

So we are led to thinking of some targets as having high inherent entropy, like fishing vessels, while others may only appear to have a high entropy because of the rate at which we

have chosen to sample their position. In Shannon's terms, we have selected but not transmitted several messages in between the ones actually received. Thus, the Markov process appears to have a much less probabilistic nature than it in fact has.

But now that we have found something which is analogous to entropy in our model of the C^2 process, let us return to some other considerations which our first, ideal gas, analogy hinted at.

SOME ELEMENTARY RELATIONSHIPS

If we return to equation (1),

$$P_m V_r = N k T \quad (1)$$

one of the first things we can ask is how the volume of responsibility is to be defined. In a chemical system, it is the volume of some form of container with which we understand we are dealing. What is the analogous volume in a command control system or process?

Because the lateral extent of military operations generally greatly exceeds their vertical extent, let us normalize our equation to a unit height, and deal only with area explicitly. In this case, we can define several areas (or volumes) with which we are concerned.

Following Dr. Conley's usage, we can recognize an area of responsibility A_r which is generally assigned the commander by higher authority. In addition, we can define an area of influence (A_I) within which the commander can exert his influence or control, and an area of surveillance (A_S) within which he can keep track of where things are. It will also be convenient at times to discuss an area of awareness (A_a) within which he knows where things are by

means of data supplied to him from the external to his command control process.

Now let us consider how we can determine the size of some of these areas. Although there is an analogous development for the offensive case, the defensive case is perhaps easiest to see.

Slide 19. Let us suppose our system is to deny an enemy the ability to inflict damage within a circle of radius R_d ($A_r = \pi R_d^2$). If the enemy has available air-launched missiles of range R_w , we would like to engage and destroy the aircraft before it had a chance to launch its weapon. Under these conditions, if the attacking aircraft have velocity V_a and the defending aircraft have velocity V_d , we must commit the defense well before the attacker reaches a distance R_w from the perimeter of the defended area.

In fact, it is easy to see that, if the defenders were launched immediately on the detection of an incoming raid, we would need to extend our surveillance area beyond the weapons range by enough distance to allow the defenders to reach and engage the enemy prior to weapons release. This condition sets the radius to which our surveillance must be extended around the force (R_s). In particular, it can be shown that:

$$R_s = (R_w + R_d) \left(1 + \frac{V_a}{V_d}\right) \quad (2)$$

Thus for a simple case in which both aircraft have the same speed, and we are defending only a small area, our surveillance must reach at least twice as far as the weapon range. So for a reasonable

Defended Area = πR_D^2

Weapon Range = R_W

Attack Velocity = V_A

Defense Velocity = V_D

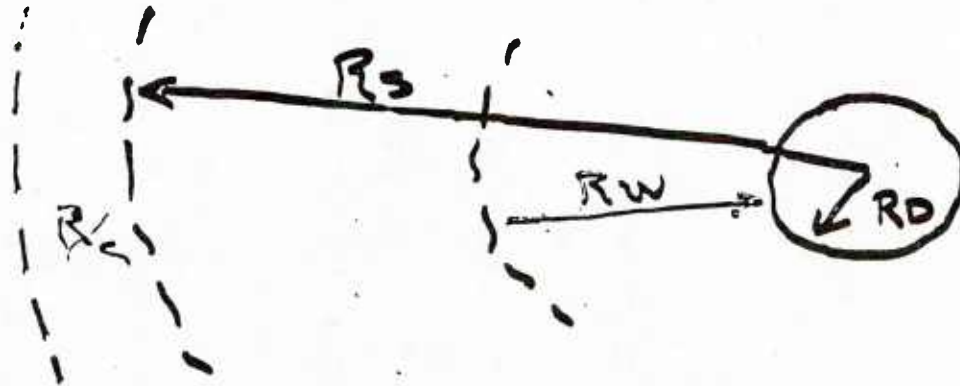

$$t = \frac{R_D + R_W}{V_D} = \frac{R_S - (R_W + R_D)}{V_A}$$

$$R_S = R_W \left(1 + \frac{V_A}{V_D} \right)$$

$$R_e = V_A t_c$$

t_c = Command decision time

missile range of perhaps 200 miles--the environment with which we must deal extends out to 500 to 600 miles.

In addition, if the process of detecting and classifying the target and deciding to engage it takes a time t_c , then our surveillance range must be extended by an additional "decision radius" R_c given by:

$$R_c = V_a t_c \quad (3)$$

Slide 20. For a numerical example, let us assume that $V_a = V_d = 600$ knots, and t_c is five minutes. If we have $R_d = 0$ and $R_w = 250$ miles, then the area we have to surveil goes from

$$A_1 = \pi R_s^2 + 7.85 \times 10^5 \text{ sq. miles} \quad (4)$$

$$A_2 = \pi(R_s + R_c)^2 = 9.50 \times 10^5 \text{ sq. miles} \quad (5)$$

So that five minutes delay in our C^2 process means that we have nearly an additional hundred fifty thousand square miles of ocean which we have to keep under surveillance. Now, of course, in the real world there are constraints which confine likely threats to certain general sectors, and so on. But the fact remains that the size of the environment we must deal with depends on both the weapons range and on the response time of our C^2 process.

$$V_R = V_D = 600 \text{ knots}$$

$$R_D = 0 \text{ (point defense)}$$

$$R_W = 250 \text{ miles}$$

$$\underline{t_c = 0:}$$

$$A_S = \pi R_S^2 = 7.8 \times 10^5 \text{ sq miles}$$

$$\underline{t_c = 5 \text{ min:}}$$

$$A_S = \pi (R_S + R_c)^2 = 9.5 \times 10^5 \text{ sq. mi.}$$

In our ideal gas equation, we included T as the "tempo of operations" and assigned the arbitrary constant k the units of time. So it seems that somewhere in here there should be a means of determining another relationship which would allow us to evaluate the constant k. This relation has not yet been found, but perhaps there is a "quantum of time" which applies to C^2 system.

There is another relationship which we can devise from first principles which connects the weapons range to at least part of the number of forces (N) which we must have to maintain equilibrium in our system.

In order to be able to maintain a reasonable up-to-date geographic display, we need reasonably frequent reports on the location of the objects within our surveillance area.

And it can be shown that the probability of correctly associating a report with the object to which it belongs has the form:

$$P = \frac{1}{T + \rho \Delta A} \quad (6)$$

where ρ is the density of objects per square mile and ΔA is the uncertainty in the (dead-reckoned) present position of the object in the data base.

Now, if there are N_0 objects in the surveillance area,

$$\rho = \frac{N_0}{A_s} \quad (7)$$

$$P = \frac{1}{1 + \rho \Delta A}$$

$$\rho = \frac{N_0}{A_s}$$

$$P = \frac{1}{1 + N_0 \left(\frac{\Delta A}{A_s} \right)}$$

$$\left(\frac{\Delta A}{A_s} \right) \approx \text{Entropy?}$$

and we can rewrite (6) in the form:

$$p = \frac{1}{1 + N_0 \left(\frac{\Delta A}{A_S} \right)} \quad (8)$$

And we see that the quantity $(\Delta A/A_S)$ is a dimensionless fraction which looks like the uncertainty in that object's location. This, in turn, reminds us that the entropy of a system is related to the sum of the probabilities that it is located in various states. So we are tempted to refer to this ratio $(\Delta A/A_S)$ as the entropy value of that object.

Slide 22. Going on, we note that if we are dead reckoning an object, and the uncertainty in our estimate of its course and speed are $\pm\Delta\theta$ and $\pm\Delta v_0$, then our "uncertainty area" for that object is given by:

$$\Delta A = 4V_0 \cdot \Delta\theta \cdot \Delta V_0 \cdot t^2 \quad (9)$$

where: V_0 = speed of the object

$\Delta\theta$ = uncertainty in object's course

ΔV_0 = uncertainty in object's speed

t = time since last observation.

using equation (2), we see our surveillance area is given by:

$$A_S = 2\pi R_S^2 = 2\pi R_S^2 \left(1 + \frac{V_a}{V_d}\right)^2 \quad (10)$$

which gives us one way to calculate the "entropy value" of the object in terms of the performance values (ranges and speeds) of real military objects and systems.

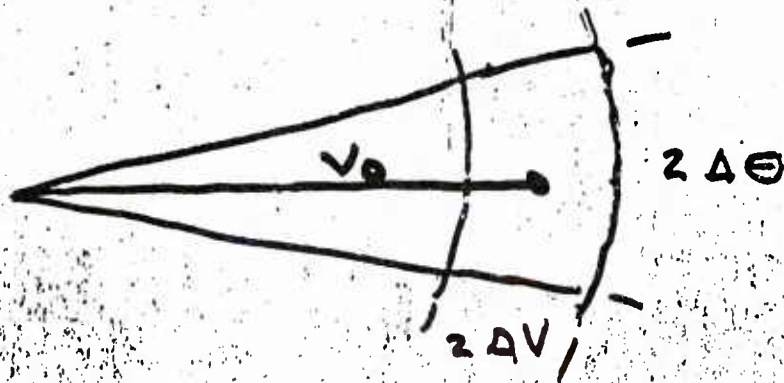

$$\Delta A = 4 v_0 \cdot \Delta\Theta \cdot \Delta V \cdot t^2$$

$$A_s = \pi R_s^2 = \pi \left(1 + \frac{v_A}{v_0}\right)^2 R_w^2$$

$$A_s = N_s v_s S t \quad \text{sq. mi}$$

$$t = \frac{A_s}{N_s v_s S}$$

Another substitution allows us to estimate the surveillance forces needed. If we have N_s surveillance aircraft, equipped with radars which give them an effective sweep width of S miles and they have a velocity V_s , then the area they can search in time t is just:

$$A_s = N_s \cdot V_s \cdot S \cdot t \text{ sq. miles} \quad (11)$$

From this it is evident that the minimum time between observations of a particular object is just

$$t = \frac{A_s}{N_s \cdot V_s \cdot S} \quad (12)$$

substituting (12) into (9) we have that

$$\Delta A = 4V_o \cdot \Delta\theta \cdot \Delta V_o \left(\frac{A_s}{N_s V_s S} \right)^2 \quad (13)$$

Slide 23

Using equation (10), we can rewrite (6) in the form:

$$P = \frac{1}{1 + \gamma (R_s^4 / N_s^2)} \quad (14)$$

where $\gamma = 4\rho V_o \cdot \Delta\theta \cdot \Delta V_o \cdot \Pi^2 (V_s S)^{-2}$

If we assume we want a probability of correctly associating reports of 85 percent and we assume reasonable values for the other quantities, we can solve this equation for the dependence

$$P = \frac{1}{1 + \gamma \left(\frac{R_s^4}{N_s^2} \right)}$$

$$\gamma = 4\rho V_0 \cdot \Delta\theta \cdot \Delta V_0 \cdot \pi^2 (V_s S)^{-2}$$

$$V_0 = 20 \text{ knots}$$

$$\Delta\theta = 30$$

$$\Delta V_0 = 2 \text{ knots}$$

$$V_s = 300 \text{ knots}$$

$$S = 200 \text{ miles}$$

$$\rho = 5 \times 10^{-4}$$

$$\gamma = 1.15 \times 10^{-17}$$

For $P = .85$:

$$N_s = 8.06 \times 10^{-6} R_s^2$$

of surveillance force weapons range. For example,
for the values in table I:

$V_0 = 20$ knots	$V_S = 300$ knots
$\Delta\theta = 3^\circ$	$S = 200$ miles
$\Delta V_0 = 2$ knots	$\rho = 5 \times 10^{-4}$

Table I.

We have:

$$\gamma = 1.15 \times 10^{-11} \quad (10)$$

and:

$$P = \frac{1}{1 + 11.5 \times 10^{-12} (R_S^4 / N_S^2)} \quad (11)$$

$$\text{or for } P = .85: \quad N_S = 8.06 \times 10^{-6} R_S^2 \quad (12)$$

So for our previous case of a 500-mile surveillance radius, we need two surveillance aircraft, but we must increase the number to three to maintain our performance if we have the five-minute delay in decision making we postulated before.

Of course, if the defending interrupters had a speed advantage over the attacking missile launchers, we could reduce our surveillance radius with a corresponding savings in surveillance aircraft.

There is another, , calculation that one can do with regard to a long range missile. Suppose we have a missile which will fly out and attack the first thing it sees after some given range. It's fairly simple to calculate the probability of hitting a target given the target's velocity, the missile speed, and the shipping

Slide 24. density. This slide shows a nomograph of such a scenario. With it you can do all kinds of trade-offs between missile speeds and launch ranges and other interesting things. And in particular, a change in the accuracy with which the target location is known at the time of launch is equivalent to moving along the axis on the box labelled "missile speed." For instance, a three-mile uncertainty in target location would move the vertical line out to nine miles and drop the probability of attacking the correct target to .84 from .90. Of course you could "buy" back some of that performance by using a much faster missile, as can easily be seen from the nomograph.

The interesting conclusion that all this leads to is that we can do some sort of micro-state calculations about the command control process. We can actually sit down and calculate what missile speed we need for a given hit probability as a function of the number of surveillance aircraft we have to update our target file.

507

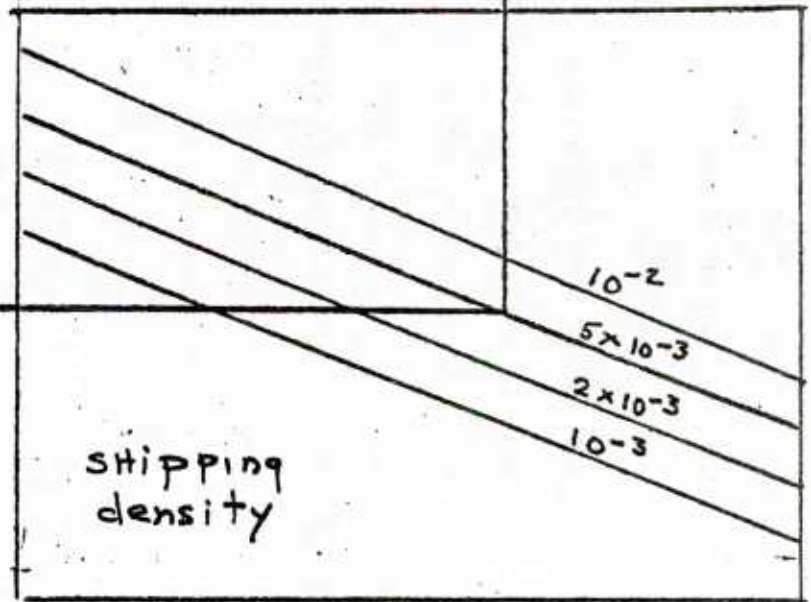
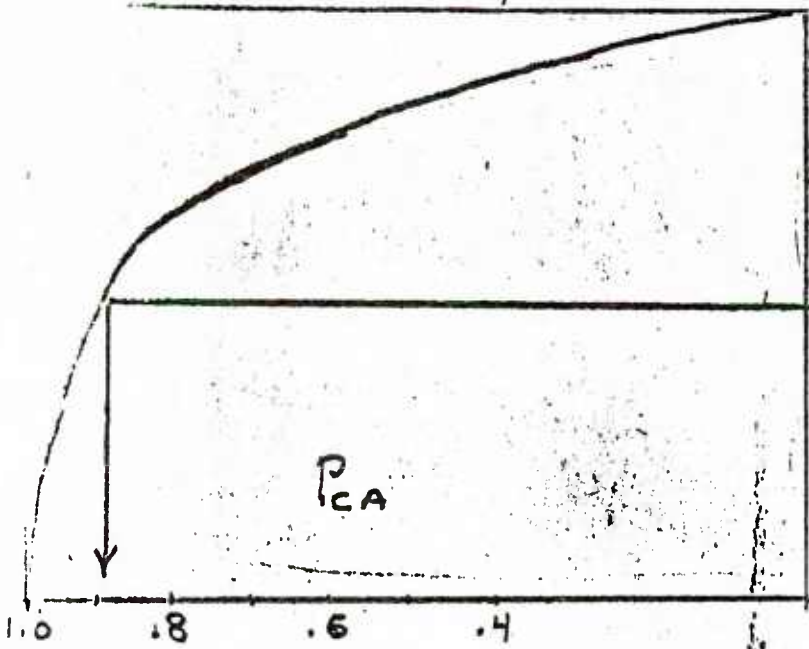
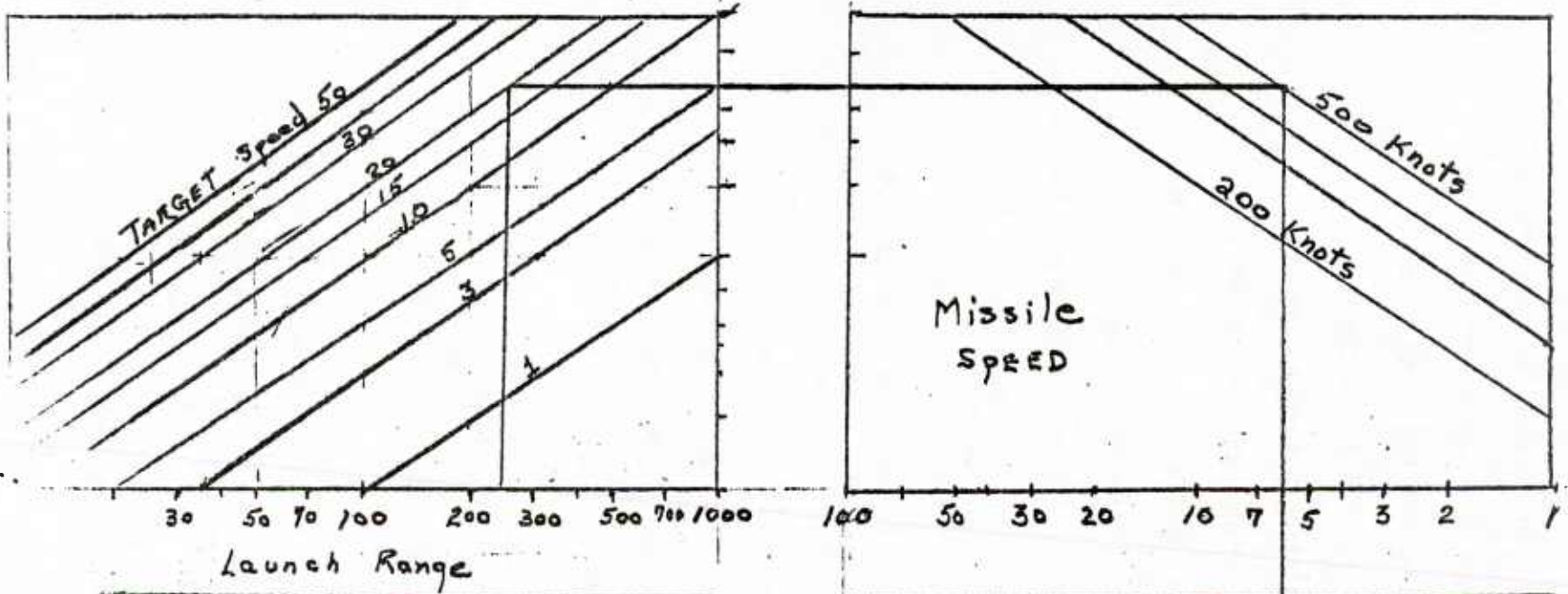

These relations are all very interesting, but they don't really involve the sorts of things we have come to think of as state variables in classical thermodynamics. Yet they clearly seem to be closely related--just as the individual momentum vectors of the molecules of a gas add up to produce what we call the pressure of the gas.

In closing, I'd like to return to my "ideal gas" analogy and extend it one more step--into quantum mechanics! When I first put this equation, $PV = NKT$, up, I suggested that T might be thought of as the "tempo of operations" and gave as an example the miles steamed per unit time. If, instead of that, we use a definition of tempo as "actions" per unit time (which may make more sense) then we are led immediately to an interesting analogy. Recalling that frequency is the reciprocal of time, we can express T in terms very familiar to the quantum mechanical world. Specifically, T looks like a quantum of energy, $h\nu$.

What this means, I don't know; but it does look as though an interesting thing to do would be to work out a definition of a military quantum. Could it be delivering one round on a target, or drafting a message, or transmitting one report? I'm not sure, but I think that if we had a concept of what an elementary military action was, perhaps that would be the key to relating an infinity of complicated little micro-states with a more generalized, macrostate view of the command control process.

$$P_M V_R = N k T$$

T = "Tempo of Operations"

T \neq miles steamed / time!

T = "Actions" / time

= Action · frequency

$T \approx h \nu$?

Perhaps during the rest of this workshop, with all of
you working on the problem, we can arrive at such a concept.

(Editor's note: we didn't!) Thank you.

U249480

DUDLEY KNOX LIBRARY - RESEARCH REPORTS



5 6853 01064052 7

