



## Report Title

### Normal Coagulation

#### ABSTRACT

##### Maintenance

life. Blood flow may be lost because of pump failure, leakage of blood, or blood vessel obstruction. The coagulation system has evolved to deal with the last two events by providing qualities that maintain blood in a fluid state within the vasculature. This challenge is met by a three-component system that promotes vascular blood fluidity while anticipating the requirement for blockade of extravascular blood flow. The system involves vascular endothelial cells, blood, and extravascular tissue. These three compartments maintain fluidity or produce an integrated response to attenuate blood leakage by localized clotting at the site of vascular injury, with the dimensions of the response in proportion to the injury.

The processes of blood coagulation and fibrinolysis are the primary defense systems of the vasculature. The opposing forces of fibrin clot formation and dissolution maintain hemostasis and preserve vascular function and integrity. Procoagulant events that culminate in generation of  $\alpha$ -thrombin and formation of a fibrin clot protect the vasculature from perforating injury and excessive blood loss. Fibrinolysis removes the clot and initiates mechanisms involved in tissue repair and regeneration. Hemostasis therefore refers to multiple discrete processes that center on  $\alpha$ -thrombin generation, fibrin clot formation, and fibrin clot dissolution.

Circulating and adherent cells and circulating and cell membrane-associated proteins carry out key roles in the coagulation and fibrinolytic pathways. Hemostasis is not a passive state but instead is actively maintained by the vascular system. Specific cellular and protein interactions are required to maintain a state of equilibrium. When the system is perturbed, an integrated series of processes are required to initiate procoagulant events and to promote fibrinolysis and tissue repair. Each individual process that contributes to hemostasis must operate properly or the entire system is compromised. A balance among procoagulant, anticoagulant, and fibrinolytic factors is required to prevent uncontrolled bleeding or, conversely, excessive clot formation.<sup>1</sup>

Many of the processes involved in hemostasis are not well understood. Epidemiologic studies have expanded our knowledge about key factors that determine the risk of cardiovascular disease.

However, cardiovascular disease is still the primary cause of death in the United States and western

Europe. To more effectively treat and ultimately prevent cardiovascular events, we continue to examine the processes that contribute to blood coagulation and fibrinolysis. In the following sections, we summarize the current concepts governing the roles of protein components: their structures, functions, and regulation. This is followed by descriptions of their dynamic relationships and techniques for monitoring of these processes.

## SECTION 7

# BLEEDING AND CLOTTING

FRED A. WEAVER

- CHAPTER 34 **Normal Coagulation** 528  
KENNETH G. MANN / KATHLEEN E. BRUMMEL-ZIEDINS
- CHAPTER 35 **Antithrombotic Therapy** 549  
IQBAL H. JAFFER / JEFF I. WEITZ
- CHAPTER 36 **Thrombolytic Agents** 567  
WESLEY K. LEW / FRED A. WEAVER
- CHAPTER 37 **Coagulopathy and Hemorrhage** 582  
JEFFREY H. LAWSON / KYLA M. BENNETT
- CHAPTER 38 **Hypercoagulable States** 599  
HOWARD A. LIEBMAN / ILENE CEIL WEITZ

Author: Cronenwett & Johnston;

## CHAPTER 34

c00034

# Normal Coagulation

KENNETH G. MANN / KATHLEEN E. BRUMMEL-ZIEDINS

p0010 **M**aintenance of blood flow is essential to life. Blood flow may be lost because of pump failure, leakage of blood, or blood vessel obstruction. The coagulation system has evolved to deal with the last two events by providing qualities that maintain blood in a fluid state within the vasculature. This challenge is met by a three-component system that promotes vascular blood fluidity while anticipating the requirement for blockade of extravascular blood flow. The system involves vascular endothelial cells, blood, and extravascular tissue. These three compartments maintain fluidity or produce an integrated response to attenuate blood leakage by localized clotting at the site of vascular injury, with the dimensions of the response in proportion to the injury.

p0015 The processes of blood coagulation and fibrinolysis are the primary defense systems of the vasculature. The opposing forces of fibrin clot formation and dissolution maintain hemostasis and preserve vascular function and integrity. Procoagulant events that culminate in generation of  $\alpha$ -thrombin and formation of a fibrin clot protect the vasculature from perforating injury and excessive blood loss. Fibrinolysis removes the clot and initiates mechanisms involved in tissue repair and regeneration. Hemostasis therefore refers to multiple discrete processes that center on  $\alpha$ -thrombin generation, fibrin clot formation, and fibrin clot dissolution.

p0020 Circulating and adherent cells and circulating and cell membrane-associated proteins carry out key roles in the coagulation and fibrinolytic pathways. Hemostasis is not a passive state but instead is actively maintained by the vascular system. Specific cellular and protein interactions are required to maintain a state of equilibrium. When the system is perturbed, an integrated series of processes are required to initiate procoagulant events and to promote fibrinolysis and tissue repair. Each individual process that contributes to hemostasis must operate properly or the entire system is compromised. A balance among procoagulant, anticoagulant, and fibrinolytic factors is required to prevent uncontrolled bleeding or, conversely, excessive clot formation.<sup>1</sup>

p0025 Many of the processes involved in hemostasis are not well understood. Epidemiologic studies have expanded our knowledge about key factors that determine the risk of cardiovascular disease. However, cardiovascular disease is still the primary cause of death in the United States and western

Europe. To more effectively treat and ultimately prevent cardiovascular events, we continue to examine the processes that contribute to blood coagulation and fibrinolysis. In the following sections, we summarize the current concepts governing the roles of protein components: their structures, functions, and regulation. This is followed by descriptions of their dynamic relationships and techniques for monitoring of these processes.

## PROCOAGULANT, ANTICOAGULANT, AND FIBRINOLYTIC PROTEINS, INHIBITORS, AND RECEPTORS

s0010

### History and Nomenclature

s0015

Current knowledge of the components involved in the p0030 complex process of blood coagulation (Fig. 34-1) is the result of observations that date to the second century, when it was noted that if two brothers died of bleeding after circumcision, the third must not be circumcised.<sup>2</sup> During the centuries, many hypotheses were envisioned about the transformation of fluid blood to a gel-like mass as it escaped the body.<sup>3</sup> These included speculations that blood clotted because it cooled on exposure to air or that it dried as it left the body.<sup>4</sup> The realization that clots stem blood loss did not occur until the beginning of the 18th century,<sup>3,4</sup> and it was not until the 19th century that the existence of thrombin, the key enzyme in blood coagulation, was recognized.<sup>3,5</sup>

In 1905, Paul Morawitz hypothesized that in the presence p0035 of  $\text{Ca}^{2+}$  and “thromboplastin,” prothrombin was converted to thrombin, which in turn converted fibrinogen to the fibrin clot.<sup>6</sup> Four clotting factors were identified: factor I, fibrinogen; factor II, prothrombin; factor III, thromboplastin; and factor IV, calcium ion. As more coagulation factors were identified, initially by bleeding pathology and subsequently by laboratory clotting tests,<sup>7,8</sup> they were assigned consecutive Roman numerals, with activated forms distinguished by an *a* after the Roman numeral designation.

To describe the multiple simultaneous processes involved p0040 in generation of a hemostatic response, we identify an inventory of the procoagulant, anticoagulant, and fibrinolytic participants in blood coagulation. Subsequently we describe the

F

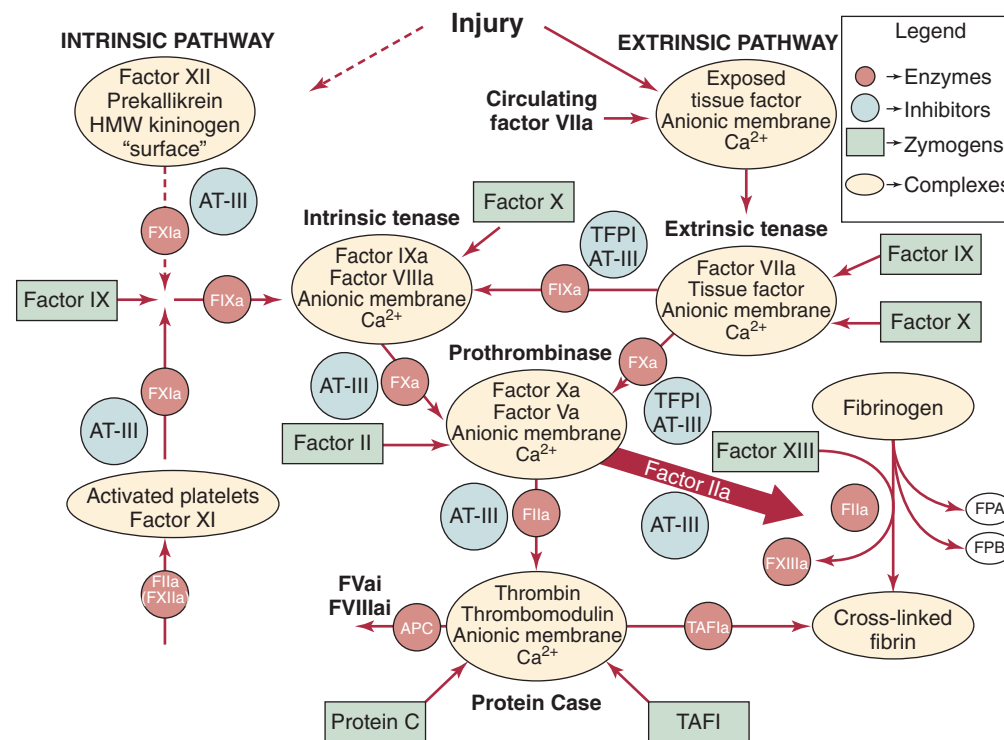

**Figure 34-1** Overview of hemostasis. Two pathways can be used to initiate coagulation: the primary extrinsic pathway (shown on the right) and the accessory pathway (historically called the contact or intrinsic pathway, shown on the left). *AT*, Antithrombin; *HMW*, high-molecular-weight; *TAFI*, thrombin-activatable fibrinolysis inhibitor; *TFPI*, tissue factor pathway inhibitor. (Modified from Brummel-Ziedins K, et al: Chapter 21 In Lee GR, et al, editors: *Wintrobe's clinical hematology*, ed 11, Philadelphia, 2003, Lippincott Williams & Wilkins.)

f0010

connections between these components and the dynamics of the process.

### s0020 Vitamin K-Dependent Proteins

p0045 The vitamin K-dependent proteins, synthesized in the liver, play central roles through either procoagulant or anticoagulant functions. The family includes the procoagulant factors VII, IX, X and prothrombin and the anticoagulants protein C, protein S, and protein Z (Fig. 34-2 and Tables 34-1 and 34-2). Except for protein S and protein Z, these proteins in their active forms are serine proteases related to trypsin. Cleavage of specific peptide bonds converts the vitamin K-dependent zymogens to their active serine protease forms. All share noncatalytic domains, each of which is characterized by highly conserved regions that provide specific binding characteristics essential for their function. The domain organizations of the vitamin K-dependent proteins are illustrated in Figure 34-2. (For reviews on vitamin K-dependent proteins, see references 9 to 13).

p0050 Vitamin K is essential for the biosynthesis of these clotting factors by participating in a cyclic oxidation and reduction process that converts 9 to 13 amino-terminal glutamate residues into  $\gamma$ -carboxyglutamate residues (Gla) (for review, see references 12, 14, and 15). This posttranslational modification enables the vitamin K-dependent proteins to interact with  $\text{Ca}^{2+}$  and membranes.<sup>16,17</sup> Inhibition of the Gla residue modification is the basis for “blood-thinning” anticoagulant therapy with coumarin derivatives (e.g., warfarin), which are chemically similar in structure to vitamin K and interfere with the redox cycle. The level of anticoagulation achieved

with vitamin K antagonist therapy in individuals taking the same dose regimen is variable.<sup>18,19</sup> Altered sensitivity to warfarin has been identified in patients when it is prescribed after surgery.<sup>20</sup> Factors affecting the efficacy of treatment include liver function in the synthesis of clotting factors, influence of other medications, and dietary intake and absorption of vitamin K.<sup>21</sup> Therefore, monitoring of oral anticoagulant therapy with the prothrombin time is essential.<sup>18,19</sup> New specific, active site-directed synthetic oral anticoagulants that do not require monitoring have recently been approved (i.e., rivaroxaban, dabigatran).<sup>22</sup>

$\text{NH}_2$ -terminal Gla domains are followed by either a Kringle domain in factor II or an epidermal growth factor like-domain in factor VII, factor IX, factor X, protein C, protein S, and protein Z (see Fig. 34-2). Protein S is not a serine protease precursor but instead contains a thrombin-sensitive region before the epidermal growth factor domain and a sex hormone-binding globulin-like domain in the COOH terminus.<sup>23</sup> Protein Z contains a “pseudo-catalytic domain” in the COOH terminus and is not a zymogen.<sup>24</sup>

### Cofactor Proteins

Cofactor proteins (Fig. 34-3) either circulate in plasma (factor V and factor VIII) or are the cell-bound tissue factor (TF) and thrombomodulin (TM).

### Soluble Plasma Procofactors

**Factor V.** Factor V is a large single-chain glycoprotein<sup>25-28</sup> that circulates in plasma (see Fig. 34-3A and Table 34-1) and in the alpha granules of platelets; the 18% to 25% of the total

SECTION 7  
BLEEDING AND CLOTTING  
s0025

F

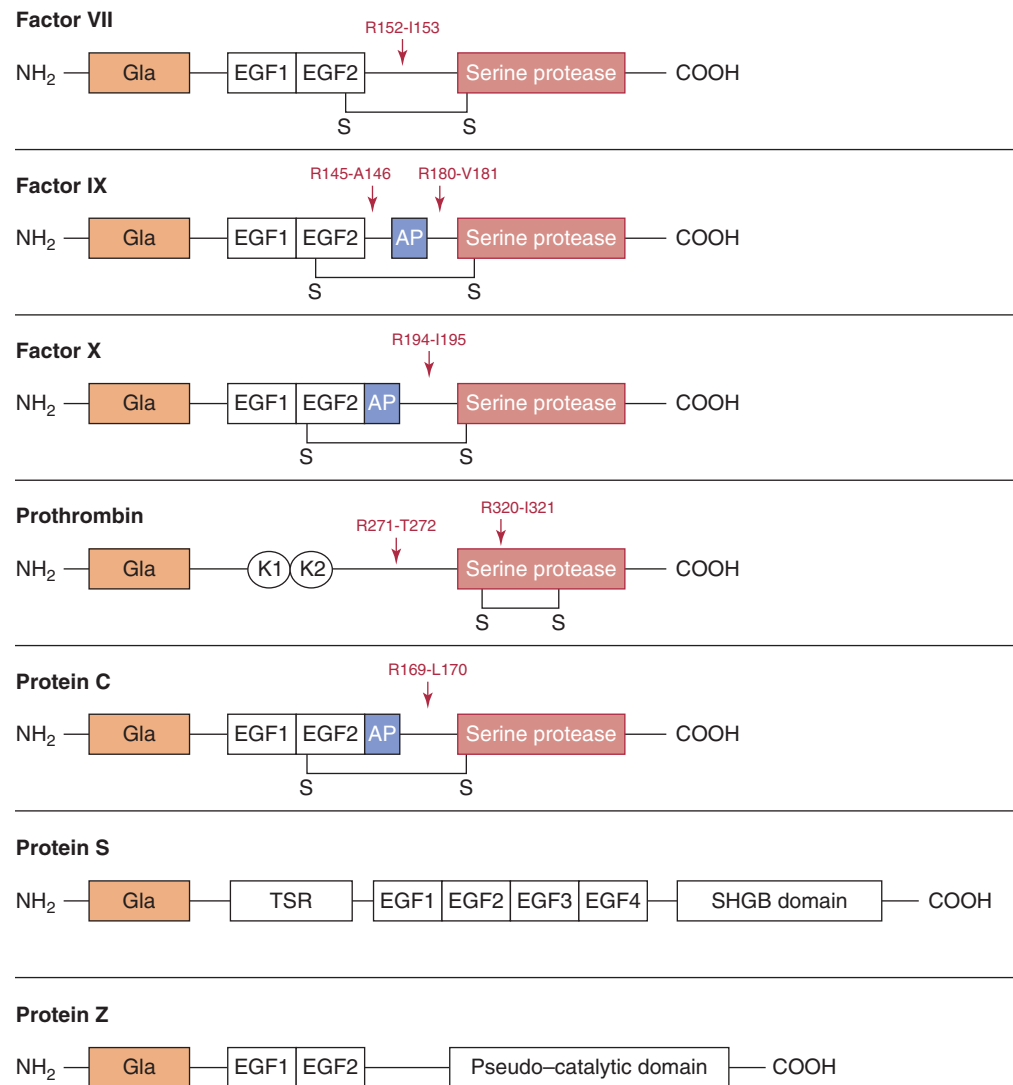

f0015

**Figure 34-2** Schematic representation of the vitamin K–dependent proteins. The building blocks for these proteins include an NH<sub>2</sub>-terminal Gla domain with 9 to 13  $\gamma$ -carboxyglutamate residues followed by either an epidermal growth factor (EGF)–like domain in factor VII, factor IX, factor X, protein C, protein S, and protein Z or kringle (K) domains in prothrombin. Activation cleavage sites, disulfide bonds (-S-S-), and activation peptides (AP) are illustrated. The sex hormone–binding globulin (SHBG) and thrombin-sensitive regions (TSR) are also represented in proteins.

factor V present in platelets<sup>29</sup> is secreted on platelet activation. Factor V is cleaved at several sites by  $\alpha$ -thrombin to the cofactor factor Va.<sup>30</sup> The cleavage sites shown in Figure 34-3A excise the B region and provide a two-chain factor Va molecule that functions as a factor Xa receptor and a positive modulator of factor Xa catalytic potential in the prothrombinase complex.<sup>31</sup> Factor Va is proteolytically inactivated by activated protein C (APC)<sup>32,33</sup> with cleavage sites shown in Figure 34-3A. Cleavage at R506 reduces activity, whereas the slower cleavage at R306 eliminates activity. The importance of this regulatory mechanism is illustrated by the “APC resistance” syndrome associated with factor V Leiden.<sup>34</sup> Individuals with factor V Leiden have a G-to-A substitution at nucleotide 1691 in the factor V gene that results in an Arg506→Gln mutation.<sup>35</sup> Factor Va Leiden has normal cofactor activity in the prothrombinase complex. However,

factor Va Leiden is more slowly inactivated because the Arg506→Gln mutation eliminates the faster cleavage site. A review is available of factor V in hemostasis.<sup>31</sup>

**Factor VIII.** The procofactor factor VIII, or antihemophilic s0040 factor, circulates in plasma in complex with the large multi- p0070 meric protein von Willebrand factor (vWF; see Fig. 34-3A).<sup>36</sup> The molecule is synthesized as a single chain but proteolyzed at a variety of sites in the B chain and secreted as a two-chain molecule.<sup>37</sup> Factor VIII is activated by  $\alpha$ -thrombin cleavage at three sites (Arg372, Arg740, and Arg1689) to generate the heterotrimeric cofactor factor VIIIa.<sup>38</sup> The vWF binding site at the NH<sub>2</sub> terminus of the light chain is removed from the factor VIII protein through cleavage by  $\alpha$ -thrombin at Arg1689. Factor VIIIa forms a complex with the serine protease factor IXa, Ca<sup>2+</sup>, and a membrane, which results in the

t0010

Protein	M <sub>r</sub> (kD)	Plasma Concentration		Plasma t <sub>1/2</sub> (Days)	Clinical Phenotype*		Functional Classification
		(nmol/L)	(μg/mL)		H	T	
Factor XII	80	500	40	2-3	–		Protease zymogen
HMW kininogen	120	670	80		–		Cofactor
LMW kininogen	66	1300	90				Cofactor
Prekallikrein	85/88	486	42				Protease zymogen
Factor XI	160	30	4.8	2.5-3.3	±		Protease zymogen
Tissue factor	44			N/A			Cell-associated cofactor
Factor VII	50	10	0.5	0.25	+	±	VKD protease zymogen
Factor X	59	170	10	1.5	+		VKD protease zymogen
Factor IX	55	90	5	1	+		VKD protease zymogen
Factor V	330	20	6.6	0.5	+	+	Soluble procofactor
Factor VIII	285	1.1-1.5 <sup>†</sup>	0.3-0.4	0.3-0.5	+	–	Soluble procofactor
vWF	255	Varies	10		+		Carrier for factor VIII
Factor II	72	1400	100	2.5	+	–	VKD protease zymogen
Fibrinogen	340	7400	2500	3-5	+	±	Structural clot protein
Factor XIII	320	94	30	9-10	+	±	Transglutaminase zymogen

HMW, High-molecular-weight; LMW, low-molecular-weight; VKD, vitamin K–dependent; vWF, von Willebrand factor.

\*Clinical phenotype, the expression of either hemorrhagic or thrombotic phenotype in deficient individuals: H, hemorrhagic disease/hemophilia; T, thrombotic disease/thrombophilia; +, presence of phenotype; –, absence of phenotype; ±, some individuals present with the phenotype and others do not.

<sup>†</sup>Butenas S, et al: The influence of von Willebrand factor on factor VIII activity measurements. *J Thromb Haemost* 7:132-137, 2009; Butenas S, et al: The “normal” factor VIII concentration in plasma. *Thromb Res* 126:119-123, 2010.

“intrinsic” factor tenase. Factor VIIIa function is downregulated by the spontaneous dissociation of the noncovalently associated A<sub>2</sub> subunit produced by inactivation and by APC. Factor VIII is homologous (40% identity) with factor V.<sup>39</sup>

p0075 Deficiency of factor VIII, or hemophilia A, is a well-characterized bleeding disorder linked to the X chromosome. Severe hemophilia A therefore occurs almost exclusively in males with a frequency of 1 in 5000 to 10,000.<sup>40</sup>

### Cell-Bound Cofactors

s0045

**Tissue Factor.** TF is a transmembrane protein that functions as a nonenzymatic cofactor with factor VIIa in the extrinsic tenase complex (Fig. 34-4).<sup>41</sup> TF is not expressed in blood in the absence of injury or inflammatory stimulus. Presentation of TF to blood triggers the primary “extrinsic” pathway for hemorrhage control (see Fig. 34-1).<sup>42-44</sup> There are no known

s0050  
p0080

t0015

Protein	M <sub>r</sub> (kD)	Plasma Concentration		Plasma t <sub>1/2</sub> (Days)	Clinical Phenotype*		Functional Classification
		(nmol/L)	(μg/mL)		H	T	
Protein C	62	65	4	0.33		+	Proteinase zymogen
Protein S	69	300	20	1.75	+		Inhibitory cofactor
Protein Z	62	47	2.9	2.5	±		Inhibitory cofactor
Thrombomodulin	100	N/A	N/A	N/A			Cofactor/modulator
Tissue factor pathway inhibitor	40	1-4	0.1	6.4 × 10 <sup>-4</sup> to 1.4 × 10 <sup>-3</sup>			Proteinase inhibitor
Antithrombin	58	2400	140	2.5-3			Proteinase inhibitor
Heparin cofactor II	66	500-1400	33-90	2.5	+	±	Proteinase inhibitor
Protein C inhibitor	57	90	5	1			Proteinase inhibitor
α <sub>2</sub> -Macroglobulin	735	2700-4000	2-3000	0.002			Proteinase inhibitor
α <sub>1</sub> -Proteinase inhibitor	53	28,000-65,000	1,500-3,500	6			Proteinase inhibitor
Endothelial protein C receptor							Receptor

\*Clinical phenotype, the expression of either hemorrhagic or thrombotic phenotype in deficient individuals: H, hemorrhagic disease/hemophilia; T, thrombotic disease/thrombophilia; +, presence of phenotype; –, absence of phenotype; ±, some individuals present with the phenotype and others do not.

F

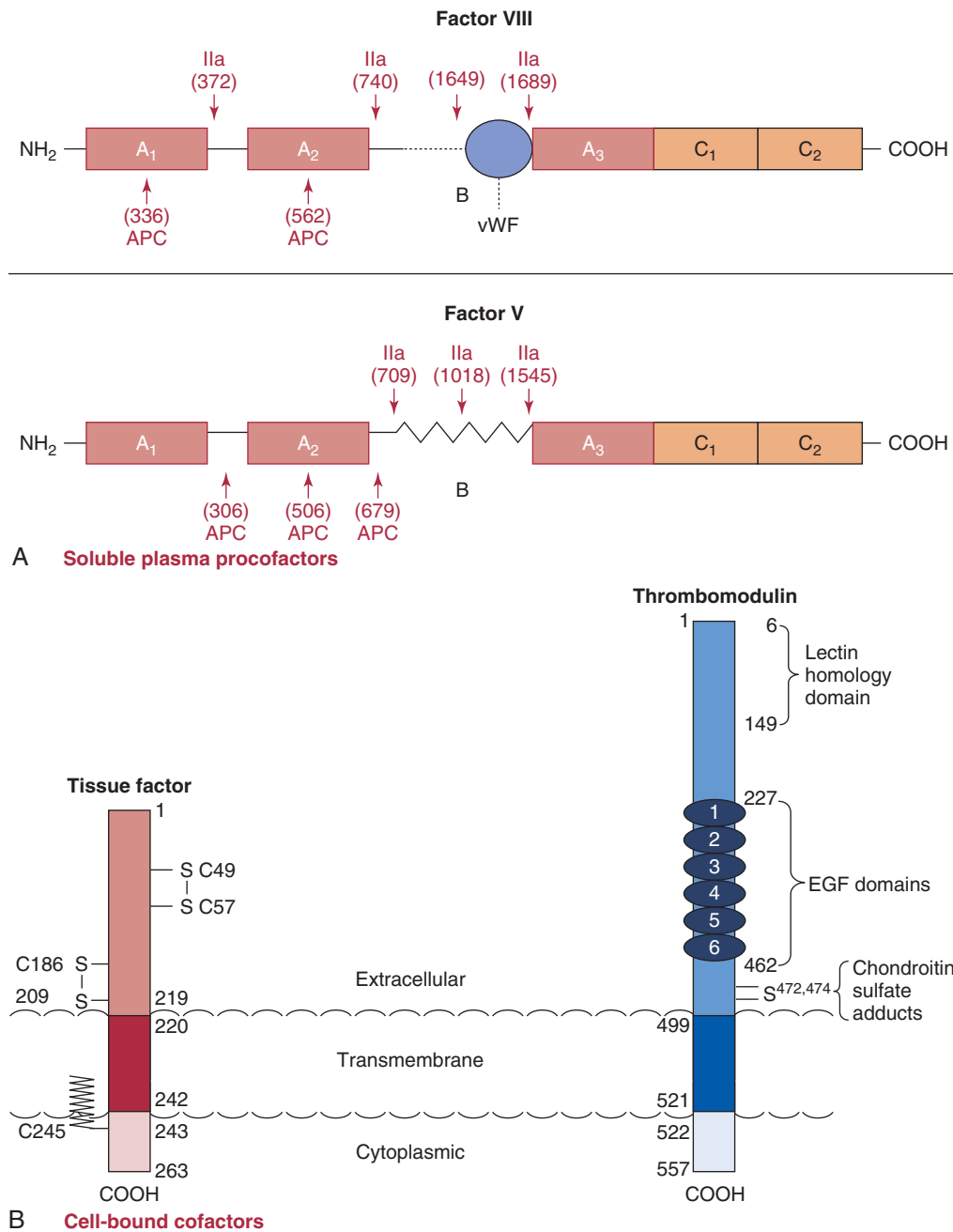

f0020

**Figure 34-3** Cofactors. **A**, Plasma procofactors factor VIII and factor V. The linear domain structures (A<sub>1</sub>-A<sub>2</sub>-A<sub>3</sub>-C<sub>1</sub>-C<sub>2</sub>) are represented. APC, Activated protein C; vWF, von Willebrand factor. **B**, Cell-bound cofactors tissue factor and thrombomodulin. Epidermal growth factor (EGF), transmembrane, and cytoplasmic domains are illustrated.

deficiencies of human TF, and absence of TF in mice is lethal during embryonic development.<sup>45</sup> The most commonly accepted sources of functional TF are the subendothelium exposed after vascular damage and monocytes stimulated by cytokines; however, there is also controversy about functional TF circulating in blood.<sup>46-50</sup>

p0085 TF is composed of an extracellular domain, a transmembrane domain, and a cytoplasmic domain. Two disulfide bonds (S-S) are identified in the extracellular domain, and the cytoplasmic cysteine (C245) is found in a thiol ester linkage to a fatty acid (see Fig. 34-3B). The extracellular

cysteines have been suggested to provide regulatory functions.

**Thrombomodulin.** TM is a type 1 transmembrane protein constitutively expressed on the surface of vascular endothelial cells (see Fig. 34-3B). Five distinct domains can be identified in TM: a lectin-like domain, a domain containing six epidermal growth factor-like regions, a small extracellular domain rich in threonine and serine residue (two, S472 and S474, as sites of chondroitin sulfate adducts), a membrane-spanning region, and a cytoplasmic tail.

F

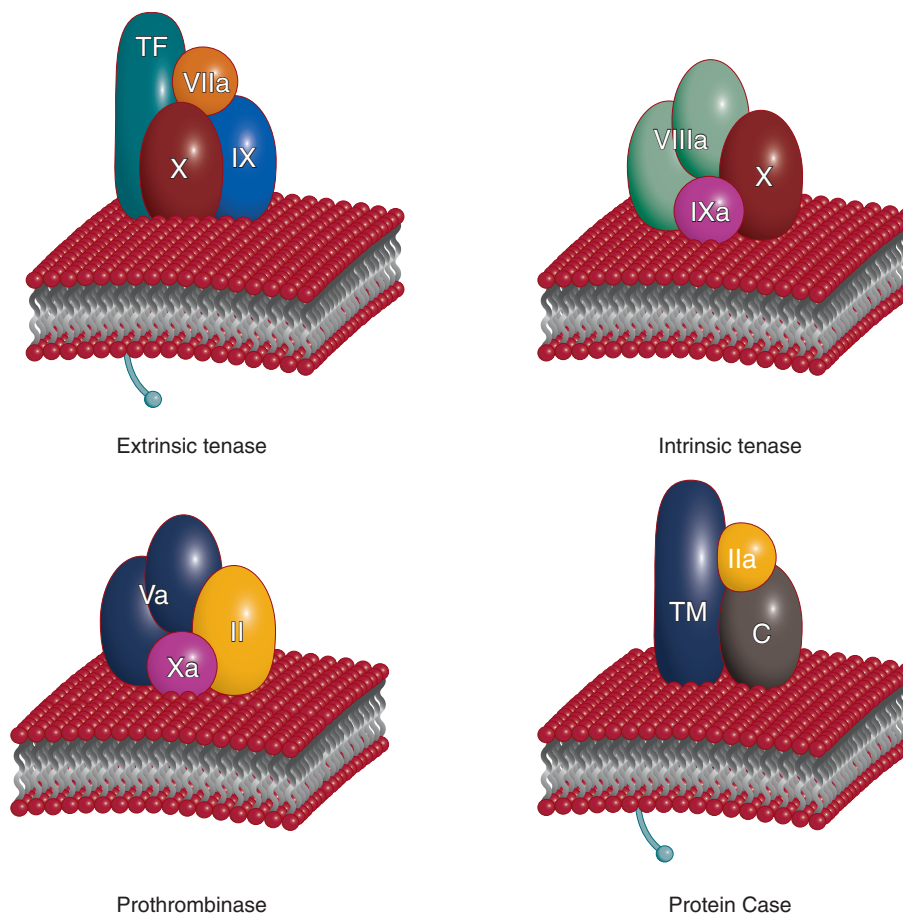

**Figure 34-4** Vitamin K-dependent complexes. Three procoagulant complexes (extrinsic tenase, intrinsic tenase, and prothrombinase) and one anticoagulant complex (protein Case) are illustrated. Each serine protease is shown in association with the appropriate cofactor protein and zymogen substrate or substrates on the membrane surface. Calcium ion is not shown. *TF*, Tissue factor; *TM*, thrombomodulin. (Redrawn from Mann KG: *Coagulation explosion*, Vermont Business Graphics, 1997.)

f0025

p0095 TM is a high-affinity receptor for  $\alpha$ -thrombin and meizothrombin and acts as a cofactor for the activation of protein C.<sup>51</sup> The endothelial cell protein C receptor provides cell-specific binding sites for both protein C and APC.<sup>52,53</sup> Once  $\alpha$ -thrombin is bound to TM, its procoagulant activities (e.g., generate fibrin; activate factor V, factor VIII, factor XI, and platelets) are neutralized and the rate of inactivation of  $\alpha$ -thrombin by antithrombin is increased.<sup>54-56</sup> Conversely, meizothrombin, an intermediate in  $\alpha$ -thrombin formation by cleavage at R320 (see Fig. 34-2), is an efficient protein C activator. APC activation by the thrombin-TM complex leads to inactivation of the cofactors factor Va and factor VIIIa, suppressing thrombin formation (see Fig. 34-2).<sup>57</sup> The thrombin-TM (protein Case) complexes also have an antifibrinolytic role through activation of thrombin-activatable fibrinolysis inhibitor (TAFI).<sup>58-60</sup>

p0100 TM activity on the surface of endothelial cells is increased by inflammatory cytokines,<sup>61</sup> and this decrease may contribute to hypercoagulation in inflammatory states.

### s0060 Complexes

p0105 Vitamin K-dependent protein complexes are essential for establishing hemostatic balance (see Fig. 34-4). Each complex is composed of a serine protease (factor VIIa, factor IXa, factor Xa, or thrombin [factor IIa]), a cofactor that

functions as a receptor/enhancer for the enzyme (factor VIIIa, factor Va, TF, TM),  $\text{Ca}^{2+}$ , and a negatively charged membrane presented by cells (e.g., endothelial cells, monocytes, platelets). There are four vitamin K-dependent enzyme complexes (see Fig. 34-4): the extrinsic tenase complex (factor VIIa-TF), the intrinsic tenase complex (factor IXa-factor VIIIa), the prothrombinase complex (factor Xa-factor Va), and the anticoagulant protein Case complex (thrombin-TM).

These membrane-bound complexes serve to localize enzymatic activity to the appropriate regional site required for their enzymatic functions. The formation of the protease-cofactor-membrane enzymatic complexes results in the only biologically relevant enzymatic activity for factor VIIa, factor IXa, and factor Xa. The thrombin-TM complex effectively converts thrombin from being a procoagulant to an anticoagulant enzyme.

When the serine protease enzyme is associated with its respective cofactor on an appropriate membrane with  $\text{Ca}^{2+}$ , the specific reactions occur at enhanced rates,  $10^4$ - to  $10^9$ -fold greater than the enzyme-substrate combination in solution.<sup>62</sup> The importance of these complexes in the formation of a hemostatic plug is to note that if it takes 4 minutes for blood to clot in a healthy person, in the absence of membrane and cofactor, blood clot formation would take approximately 3.8 years.

s0065 **Intrinsic (Accessory) Pathway Proteins**

p0120 The designation intrinsic (accessory) pathway emerged as the relationships between genetic deficiencies and bleeding pathologic processes have been established. Deficiencies of proteins associated with the intrinsic or accessory pathway (factor XII, prekallikrein, and high-molecular-weight kininogen [HMWK]) are not associated with abnormal bleeding, even after surgical challenge.<sup>63-65</sup> These proteins were initially found through laboratory clotting tests. In contrast, deficiencies of the protein components of the extrinsic or primary pathway (prothrombin and factors V, VII, VIII, IX, and X) can lead to severe bleeding diatheses.<sup>66-71</sup> The physiologic role of the accessory pathway is therefore not understood.<sup>72</sup>

p0125 Factor XI represents an intersection point for the two pathways. Individuals with factor XI deficiency (hemophilia C) express variable bleeding with surgical challenge,<sup>73,74</sup> thus establishing a role for factor XI in hemostasis. During the hemostatic process, formation of factor XIa appears to be catalyzed by  $\alpha$ -thrombin as part of a positive feedback loop stemming from  $\alpha$ -thrombin generation.<sup>75</sup> Factor XIa then functions in the propagation phase of  $\alpha$ -thrombin generation in association with the primary pathway by activation of factor IX.<sup>76</sup>

p0130 Three proteins, factor XII, prekallikrein, and HMWK, are required for activity of the intrinsic or accessory pathway, which does not require biologic activation. Factor XII and prekallikrein are zymogens that are activated to generate serine proteases, and HMWK is a nonenzymatic procofactor

(Fig. 34-5). Activation of this pathway in vitro is accomplished when factor XII autoactivates to factor XIIa with exposure to foreign surfaces, including glass, kaolin, dextran sulfate, and sulfatides.<sup>77-79</sup> The substrates for factor XIIa, prekallikrein and factor XI, exist in a noncovalent complex with HMWK and become activated to kallikrein and factor XIa, respectively.<sup>80</sup> Positive feedback loops exist in which kallikrein cleaves HMWK, thereby freeing bradykinin and allowing more prekallikrein and factor XI to associate and activate.<sup>81</sup> This pathway is also negatively regulated through cleavage of HMWK by factor XIa.<sup>82</sup>

Although these proteins have no defined role in hemorrhage control, the accessory pathway factors may play roles in disseminated intravascular coagulation associated with systemic inflammatory response syndromes<sup>83,84</sup>; they may also be involved in the promotion of thrombus stability<sup>85,86</sup> and thus may provide targets to control pathologic coagulation.<sup>87</sup> Recent evidence suggests that biologic activation of the contact pathway system may be accomplished through assembly of these proteins on endothelial cell membranes and that prekallikrein is activated by an endothelial cell membrane cysteine protease rather than by factor XII.<sup>88,89</sup> The accessory pathway is important in cardiopulmonary bypass because of contact between blood components and synthetic surfaces.<sup>84</sup>

**Stoichiometric Inhibitors**

An array of inhibitors is present in blood with both specific and broad-spectrum actions. Inhibitors of clot formation

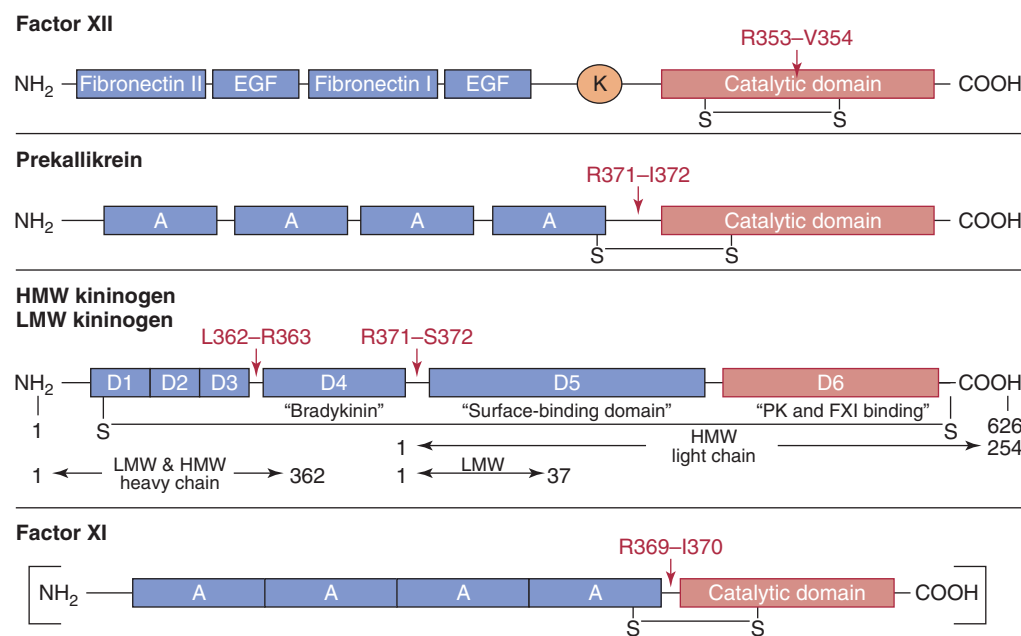

f0030

**Figure 34-5** Schematic representation of the intrinsic (accessory) pathway proteins. Factor XII, prekallikrein (PK), high-molecular-weight (HMW) kininogen, low-molecular-weight (LMW) kininogen, and factor XI (FXI) are shown with their various domains depicted. *A*, Apple domain; *EGF*, epidermal growth factor domain; *K*, kringle domain. Cleavage sites and key interchain disulfide bonds (S-S) are shown. For the kininogens, horizontal arrows indicate the amino acid residues defining heavy- and light-chain regions of the activated forms of the cofactors. The factor XI molecule is a dimer of the illustrated monomer. Factor XI is a disulfide-linked homodimer with each subunit containing four apple domains, which provide binding sites for high-molecular-weight kininogen, thrombin, factor XIIa, platelets, and heparin. Activation of factor XI (by thrombin or factor XIIa) results in a conformational change that permits factor IX binding to the apple 3 domain.

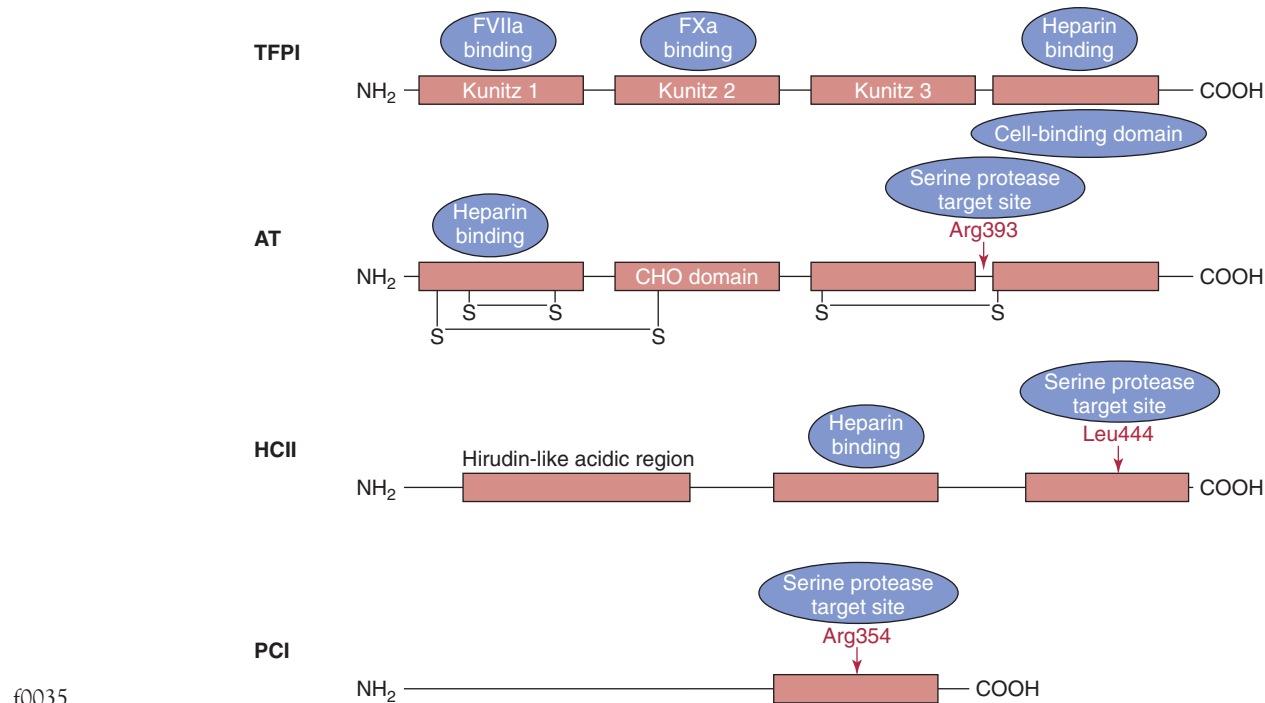

**Figure 34-6** Stoichiometric inhibitors. Tissue factor pathway inhibitor (TFPI) has three Kunitz domains (the residues are illustrated below each domain). The Kunitz 1 domain binds factor VIIa, the Kunitz 2 domain binds factor Xa, and the Kunitz 3 domain has been reported to bind protein C. The COOH terminus of TFPI contains a basic region, the cell-binding domain that also binds to heparin. Antithrombin (AT) has two intrachain disulfide bonds (-S-S-) at its NH<sub>2</sub> terminus and one in its COOH terminus with a carbohydrate-rich domain (CHO) in between. The region of interaction between the active sites of target proteases and AT is called the reactive center loop, R393-S394. Heparin binding occurs in the NH<sub>2</sub> terminus. Heparin cofactor II (HCII) contains an NH<sub>2</sub>-terminal hirudin-like region, a heparin- or dermatan sulfate-binding region, and a reactive center loop. The reactive site is Leu444. Protein C inhibitor (PCI) is a serine protease inhibitor that inhibits several proteases, including activated protein C, thrombin, and factor Xa. It is also a potent inhibitor of the thrombin-thrombomodulin complex. The reactive bond (Arg354) in the reactive center loop is shown.

are antithrombin, tissue factor pathway inhibitor (TFPI), heparin cofactor II, and protein C inhibitor (Fig. 34-6). These function to localize, limit, and control coagulation.

### s0075 Antithrombin

p0145 Antithrombin is a member of the serpin proteinase family and circulates in blood as a single-chain glycoprotein (see Fig. 34-6).<sup>90</sup> Congenital antithrombin deficiency exhibits an autosomal dominant pattern of inheritance, with an incidence of 1 in 2000 to 5000.<sup>91</sup> Individuals with this deficiency have partial expression of antithrombin and are prone to thromboembolic disease.<sup>92</sup> Complete absence of antithrombin is lethal.

p0150 Antithrombin is a broad-spectrum anticoagulant, interacting with most proteases participating in the coagulation cascade (see Fig. 34-1), including  $\alpha$ -thrombin, factor Xa, factor IXa, factor VIIa-TF, factor XIa, factor XIIa, plasma kallikrein, and HMWK.<sup>93-95</sup> Heparins and heparan sulfates potentiate these reactions and are used in the treatment of thrombosis. When antithrombin is complexed with heparin, its rate of inhibition of several coagulation proteases is accelerated by up to 10,000-fold. The general mechanism of inhibition involves reaction of the active site of the enzyme with a peptide loop structure (the reactive center loop) of antithrombin to form a tight, equimolar (1:1) complex.

Inactivation proceeds through the formation of a covalent bond between antithrombin and the protease, followed by structural rearrangements of both antithrombin and the protease. Antithrombin inhibits at a slower rate when it is not bound to heparin because the reactive center loop is not completely exposed in the absence of heparin.

Antithrombin also displays antiproliferative and anti-inflammatory properties that primarily derive from its ability to inhibit thrombin. In addition, latent or cleaved forms of antithrombin have antiangiogenic activity.<sup>96</sup>

### Tissue Factor Pathway Inhibitor

TFPI (also called extrinsic pathway inhibitor or lipoprotein-associated coagulation inhibitor) is a multivalent, Kunitz-type inhibitor that circulates in plasma as a heterogeneous collection of partially proteolyzed forms (see Fig. 34-6).<sup>97-100</sup> Ninety percent of circulating TFPI is found associated with lipoproteins, primarily low-density lipoprotein.<sup>99,101,102</sup> Parenteral TFPI is cleared from the circulation principally by the liver and has an unusually short half-life (minutes) compared with other proteinase inhibitors.

Several reviews of TFPI have been published.<sup>103-109</sup> The importance of TFPI in blood coagulation is illustrated with transgenic mice that exhibit complete deficiency (-/-) of TFPI, which is incompatible with birth and survival.<sup>110</sup>

However, this lethality can be rescued by heterozygous or homozygous factor VII deficiency,<sup>111</sup> which implies that diminishing the level of factor VII lessens the need for TFPI-mediated inhibition of the factor VIIa-TF coagulation pathway during embryogenesis.<sup>111</sup> Mice bred to have a combined heterozygous TFPI deficiency and homozygous apolipoprotein E deficiency exhibit an increased atherosclerotic burden.<sup>112</sup> These observations suggest a role for TFPI in protection from atherosclerosis and as a potential regulator of thrombosis.

p0170 TFPI is the principal stoichiometric inhibitor of the extrinsic factor tenase complex (factor VIIa-TF).<sup>113</sup> Effective TFPI inhibition of the factor VIIa-TF complex depends on the presence of factor Xa. Thus, inhibition of the extrinsic factor tenase by TFPI occurs only after significant generation of factor Xa. Inhibition by TFPI is achieved by formation of the stable quaternary complex TF-factor VIIa-TFPI-factor Xa and by formation of the factor Xa-TFPI complex.

#### s0085 Heparin Cofactor II

p0175 Heparin cofactor II is a member of the serpin family (see Fig. 34-6). Like antithrombin, heparin cofactor II inhibits thrombin in a reaction that is accelerated more than 1000-fold by heparin.<sup>114</sup> However, unlike antithrombin, the only coagulation enzyme inhibited by heparin cofactor II appears to be thrombin.<sup>115</sup> Heparin cofactor II may play a role in protection from thrombosis during pregnancy. Increased levels of dermatan sulfate in the maternal and fetal circulation<sup>116</sup> along with increased levels of heparin cofactor II in pregnant women have been reported.<sup>117,118</sup>

#### s0090 Protein C Inhibitor

p0180 Protein C inhibitor is a serpin also known as plasminogen activator inhibitor-3 (PAI-3). Protein C inhibitor is considered nonspecific in that its targets range from procoagulant (serine proteinases), anticoagulant, and fibrinolytic enzymes to plasma and tissue kallikreins, the sperm protease acrosin, and prostate-specific antigen.<sup>119,120</sup> The major target of protein C inhibitor, as its name suggests, is APC.<sup>121-123</sup> Because no patients have been documented with a deficiency, the actual function of protein C inhibitor in vivo is yet to be elucidated.

#### s0095 Endothelium and Platelets

p0185 Blood cells and the vasculature are crucial to normal hemostasis. Multiple processes involving components of the vessel wall, circulating platelets, and plasma protein moieties interact to maintain blood fluidity. These processes must be precisely choreographed to allow the vasculature to perform myriad complex physiologic activities (Fig. 34-7).

p0190 The early work of Seegers identified the phospholipid requirements for coagulation.<sup>124</sup> The biologic elements contributing to the phospholipid requirements include damaged vascular tissue, activated platelets, and inflammatory cells. These contributions of the membrane to the formation and expression of procoagulant complexes are essential. However,

the nature of the membranes that support procoagulant reactions is poorly understood. Mechanically damaged cells can provide the anionic membrane bilayer inner leaflet phospholipids, which can support general procoagulant complex formation, but more subtle cellular activation events also generate selective complex-forming sites on intact cells. Activated platelet membranes express individual binding sites for the factor IXa-factor VIIIa and factor Xa-factor Va complexes. Pathologic hemorrhage is therefore associated with thrombocytopenia and is also seen in a rare disease, Scott's syndrome, which appears to result from the improper presentation of these platelet binding sites.<sup>125</sup>

#### Endothelium

s0100

The endothelium plays key roles because of its strategic interface with organs, tissues, and circulating blood. The endothelium varies considerably in morphology and physiologic function in different parts of the vasculature. This complex cellular network not only provides a structural barrier to contain flowing blood but also actively regulates blood pressure, vascular tone, permeability, and processes involving other cells, such as smooth muscle cells, leukocytes, and platelets, and deposits an intricate basement membrane and extracellular matrix.<sup>126</sup> In addition, the endothelium is involved in inflammatory and immune responses and angiogenesis.<sup>127</sup> Defects in vascular endothelial function therefore have profound physiologic implications. Excessive bleeding can result from structural abnormalities of the endothelial cell layer or supporting matrix. Impaired plasminogen activator inhibitor-1 (PAI-1) expression or secretion (or both) by the endothelium likewise promotes bleeding through increased fibrinolytic activity.<sup>128</sup> Conversely, endothelial cells are also involved in mediating processes that lead to the formation of atherosclerotic plaque and thrombotic disease.

It is well established that activated platelets, white blood cells, and microparticles in blood can serve the receptor function for the assembly of the procoagulant complexes.<sup>129</sup> Recently, it has been observed that red blood cells, in addition to participating in the blood clotting process through their biophysical effect of causing the margination of platelets at the vessel wall during blood flow, also participate biochemically by expressing phosphatidylserine-like membrane sites that support the assembly of procoagulant complexes.<sup>130</sup>

#### Platelets

s0105

Platelets are vital to procoagulant events and contribute to the fibrinolytic process as well. Like the endothelium, the undisturbed platelet presents a nonthrombogenic surface. Important components of platelet physiology are surface adhesion protein complexes and platelet secretory granules: alpha granules, lysosomes, and dense granules. The contents of alpha granules include procoagulant and adhesive proteins such as fibrinogen, fibronectin, thrombospondin, vWF, P-selectin, HMWK, platelet factor 4, osteonectin, factor V,<sup>29</sup> and factor XI.<sup>131</sup> Other alpha granule contents,  $\alpha_1$ -antitrypsin, protein S, TFPI, and platelet inhibitor of factor XI, are

F

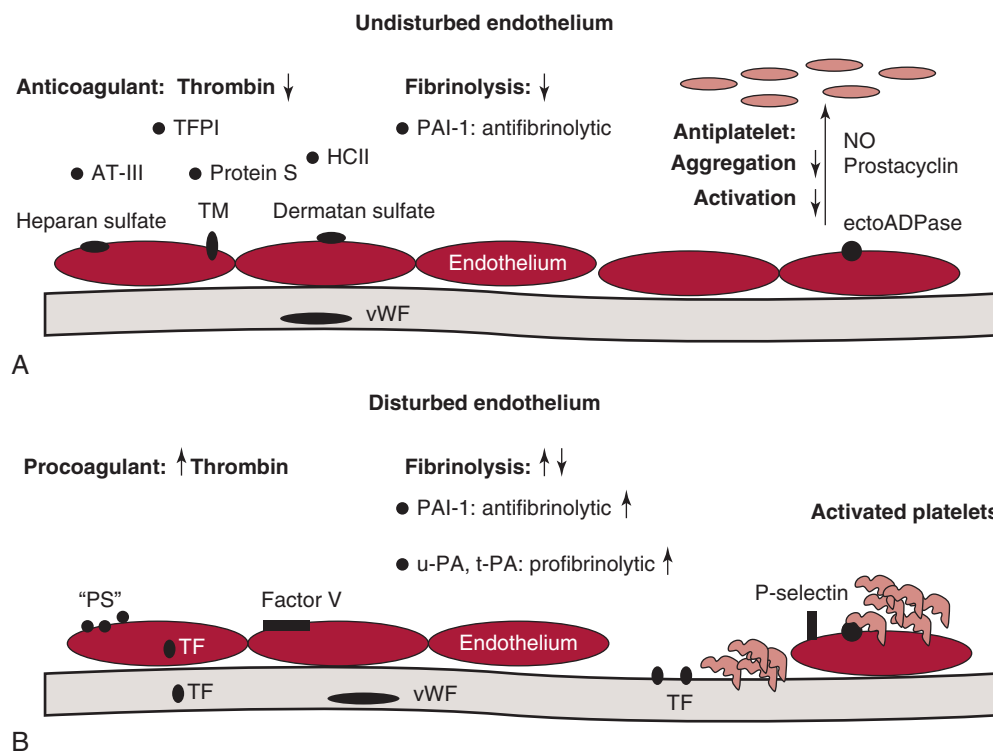

f0040

**Figure 34-7** The endothelium in hemostasis. **A**, Under normal conditions and in the absence of injury or chemical stimulus, the undisturbed endothelium actively downregulates thrombin generation through production of tissue factor pathway inhibitor (TFPI), antithrombin (AT), protein S, heparin cofactor II (HCII), heparan sulfate, thrombomodulin (TM), and dermatan sulfate. The undisturbed endothelium is also antifibrinolytic and secretes plasminogen activator inhibitor-1 (PAI-1). In the absence of stimulus, the endothelium is likewise antiplatelet and prevents platelet adhesion, activation, secretion, and aggregation through production of nitric oxide (NO), prostacyclin, and the membrane-associated protein ectoADPase. **B**, When the endothelium is disturbed, the endothelium becomes procoagulant and accelerates thrombin formation by exposing or expressing anionic phospholipid ("PS"), limited tissue factor (TF), and factor V. The fibrinolytic response is modulated by the release of both antifibrinolytic and profibrinolytic molecules. Urokinase (urinary plasminogen activator, u-PA) and tissue plasminogen activator (t-PA) are profibrinolytic and serve to activate plasminogen, whereas PAI-1 inhibits both enzymes and is antifibrinolytic. Platelet activation, secretion, and aggregation are also promoted under conditions in which the endothelium is disrupted. Exposure of von Willebrand factor (vWF) in the subendothelial matrix allows platelets to attach to the surface of the vessel. P-selectin likewise promotes platelet attachment.

involved in anticoagulant activities.<sup>132-134</sup> The alpha granule also contains proteins that mediate both profibrinolytic and antifibrinolytic processes. These proteins include plasminogen,  $\alpha_2$ -antiplasmin, factor XIII, and PAI-1.<sup>135-139</sup> In the unstimulated platelet, the granule contents remain internalized, and anionic phospholipid is sequestered in the inner leaflet of the plasma membrane. The release of prostaglandin  $I_2$  and nitric oxide from endothelial cells, the presence of CD39, and the inability of normal plasma vWF to bind spontaneously to the platelet surface are the inhibitory mechanisms that keep platelets unactivated.

p0210 When the vascular system is perturbed, platelet plug formation occurs in stages. Initially, platelets adhere and are activated by exposure to collagen, vWF, and other matrix components (Fig. 34-8). The cytoskeleton spreads, platelet-fibrinogen aggregates are formed, and the contents of the granules are secreted.<sup>140-142</sup> The activated platelets adhere to each other, endothelial cells, leukocytes, and components of the subendothelial matrix.<sup>143</sup> The phosphatidylserine-rich internal face of cell membranes is exposed and presents a highly procoagulant surface to the circulation. In addition, activated platelets express specific receptors or binding sites,

or both, for assembly of the procoagulant multiprotein complexes. There are approximately 6000 factor Va binding sites on the activated platelet membrane.<sup>144</sup> Factor Va forms part of the receptor for factor Xa. Factor Xa is also reported to bind to effector cell protease receptor-1 molecules expressed on activated platelets.<sup>144-147</sup>

$\alpha$ -Thrombin is the most potent activator of platelets, p0215 able to overcome most pharmacologic and cytokine inhibitors that depress platelet function. The mechanism by which thrombin activation of platelets occurs is novel and involves two proactivator membrane proteins on the platelet surface, platelet-activated receptors 1 and 4, which when cleaved by thrombin present new  $NH_2$  termini that insert themselves into adjacent receptors to trigger platelet activation. Platelet-activated receptor 1 appears to be the more prominent receptor activated by thrombin. Synthetic peptides representing a newly presented membrane-bound  $NH_2$ -terminus sequence can activate platelets independent of thrombin proteolytic cleavage.

During the extension phase of platelet plug formation, p0220 activated platelets accumulate on top of the initial monolayer of platelets bound to collagen. The presence of receptors on

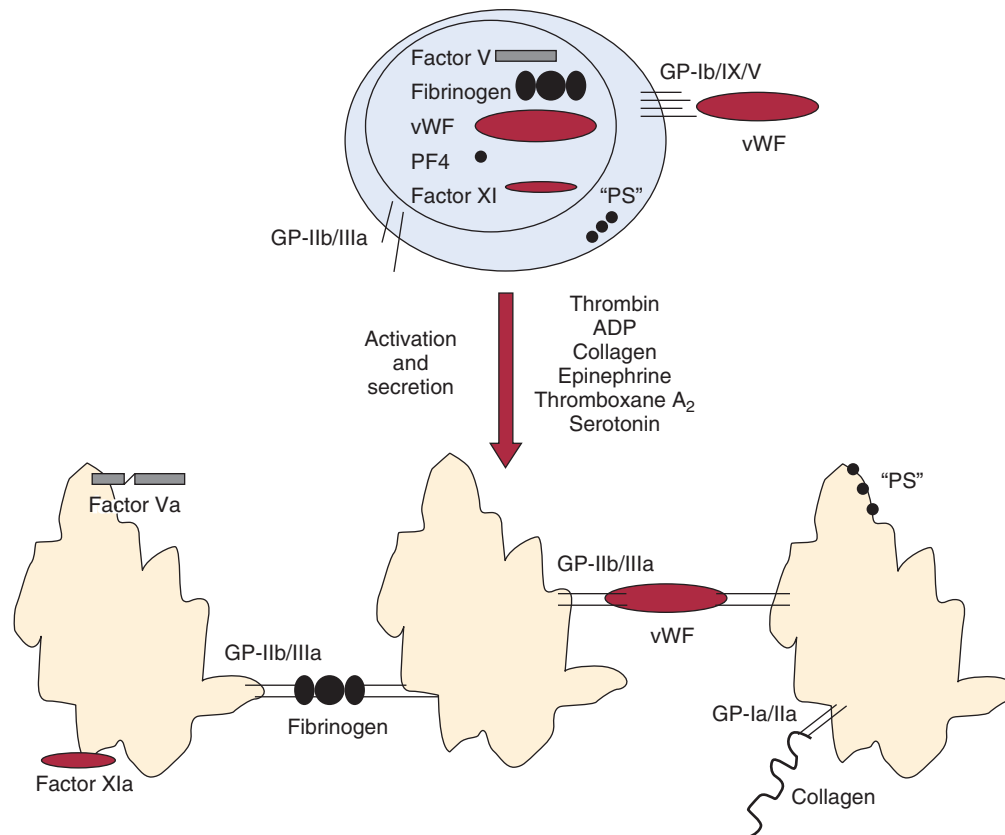

f0045

**Figure 34-8** Activation, secretion, and aggregation of platelets. Platelets have multiple functions in hemostasis. They serve as reservoirs of factor V, fibrinogen, von Willebrand factor (vWF), platelet factor 4 (PF4), and factor XI. Platelets also contribute a significant portion of the anionic phospholipid (“PS”) necessary for membrane-dependent complex formation and function. In the unstimulated state, proteins and other molecules are sequestered in the platelet granules. Anionic phospholipid is found only in the inner leaflet of the platelet membrane and is not exposed to flowing blood. The glycoprotein Ib/IX/V (GP-Ib/IX/V) complex that recognizes vWF is an active receptor, whereas the GP-IIb/IIIa receptor that recognizes a variety of molecules, including fibrinogen and vWF, is not active. The GP-Ib/IX/V receptor probably allows unstimulated platelets to attach to exposed subendothelial vWF and promotes procoagulant events before platelet activation. On activation by a variety of agonists, platelets secrete granule contents, activate and bind factor V/Va and factor XI/XIa, and expose anionic phospholipid. The GP-IIb/IIIa receptor serves to link platelets to each other and the vessel wall. Collagen receptors such as GP-Ia/IIa promote both platelet activation and aggregation.

the platelet surface allows agonists such as thrombin, adenosine diphosphate, and thromboxane A<sub>2</sub> to further recruit circulating platelets into the growing hemostatic plug. Subsequently, during the platelet plug formation perpetuation phase, close contact between platelets promotes growth and stabilization of the hemostatic plug, in part through contact-dependent signaling mechanisms.<sup>148</sup>

### s0110 Clot Proteins

p0225 The primary proteins of the clot are fibrin and the transglutaminase factor XIIIa. A central event in blood coagulation is the conversion of soluble fibrinogen (factor I) to insoluble fibrin (see Fig. 34-1; for review, see references 149 and 150). Fibrinogen serves as a molecular bridge to support interplatelet aggregation, and it is the precursor of fibrin, which is the main component of the protein scaffolding of the forming hemostatic plug (Fig. 34-9). Platelet aggregation critically depends on fibrinogen binding to activated platelets through

the platelet fibrinogen receptor glycoprotein IIb/IIIa (integrin  $\alpha\beta$ ) as well as on fibrin adhesion. Fibrinogen/fibrin also regulates thrombin activity<sup>151,152</sup> and thrombin exosite binding to fibrin, which limits the diffusion of thrombin and thereby regulates clot extension.

Although it is primarily recognized for its role in hemostasis, fibrinogen is also associated with inflammation. Fibrinogen is an acute-phase reactant, with levels increasing during inflammation. In inflammatory states, fibrinogen functions as a bridging molecule in cell-cell interactions. Fibrin and fibrinogen can modulate a variety of different cell types, including endothelial cells, epithelial cells, leukocytes, platelets, and fibroblasts. Cellular receptors that can bind fibrinogen and fibrin include the integrins  $\alpha_{IIb}\beta_3$ ,  $\alpha_v\beta_3$ , and  $\alpha_5\beta_1$  and the cellular adhesion molecules intercellular adhesion molecule-1 and vascular endothelial cadherin. The fibrin clot is stabilized by the transglutaminase factor XIIIa,<sup>153-155</sup> whose function is to cross-link fibrin and other adhesive proteins, including integrin receptors, to provide a stable network

F

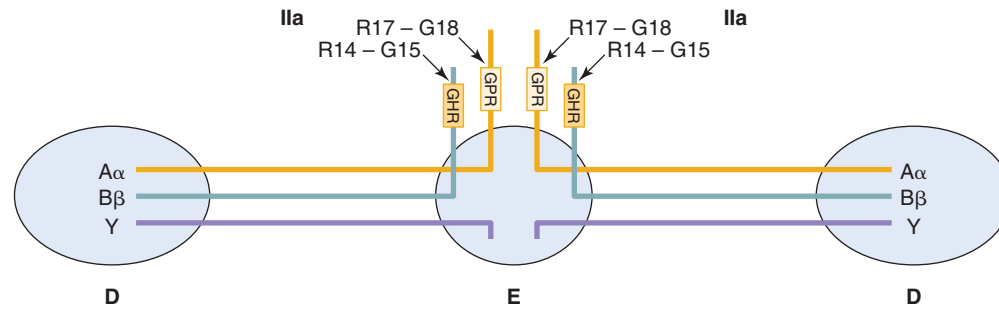

f0050

**Figure 34-9** A schematic representation of human fibrinogen. Fibrinogen is composed of six polypeptide chains (two  $A\alpha$ , two  $B\beta$ , and two  $\gamma$ ). These are organized into two identical half-molecules. All six  $NH_2$  termini are linked by disulfide bonds in the central or E domain. The three chains extend out from this domain through coiled coils in either direction, terminating in the globular D domains. Thrombin (IIa) cleavage sites at the N termini of the  $A\alpha$  and  $B\beta$  (arrows) are indicated, with the new N termini (box) that associate with "holes" in the D domains to form fibrin.

(Fig. 34-10). The protransglutaminase factor XIII circulates in plasma as a tetramer and is also present as a dimer in platelets. Activation of the protein by thrombin cleavage and  $Ca^{2+}$  binding yields factor XIIIa, which cross-links fibrin by forming exopeptide bonds between the  $\epsilon$ -amino lysyl residues and the  $\gamma$ -carboxamide groups of glutamine residues. The clot resulting from thrombin cleavage of fibrinogen to form the clot fibrin and factor XIII cross-linking create an insoluble network that, with platelets, seals the perforation in the blood vessel with a temporary scaffold, stopping further blood loss. This scaffold is ultimately removed in the fibrinolytic process and replaced by cellular reconstruction of the perforated vessel.

### s0115 Fibrinolysis Proteins

p0235 Clot formation is integrated with clot dissolution. The mechanisms of clot dissolution center on fibrin-specific reactions. The key proteins involved are plasminogen; the plasminogen activators tissue plasminogen activator (t-PA) and urokinase

or urinary plasminogen activator (u-PA); thrombin; and the inhibitors PAI-1,  $\alpha_2$ -antiplasmin, and TAFIa (Fig. 34-11 and Table 34-3).

### Fibrinolysis Activators

s0120

**Plasminogen/Plasmin.** Plasminogen is the inactive precursor of the enzyme plasmin, the primary catalyst of fibrin degradation.<sup>156</sup> Hereditary plasminogen deficiency is described either as a deficiency of plasminogen antigen and activity (type I) or as a normal antigen level but reduced activity (type II, dysplasminogenemia).<sup>157</sup> Plasminogen is also an acute phase reactant protein.<sup>158,159</sup> Homozygous plasminogen-deficient mice are viable but exhibit severe thrombosis with systemic fibrin deposition and die prematurely.<sup>160</sup> Plasminogen is synthesized in the liver and is present in a wide variety of tissues and body fluids, including saliva, lacrimal gland secretions, seminal vesicle fluid, and prostate secretions. The zymogen is converted to the serine protease plasmin by cleavage of the Arg561-Val562 peptide bond by the activators. Activation of plasminogen occurs through three pathways:

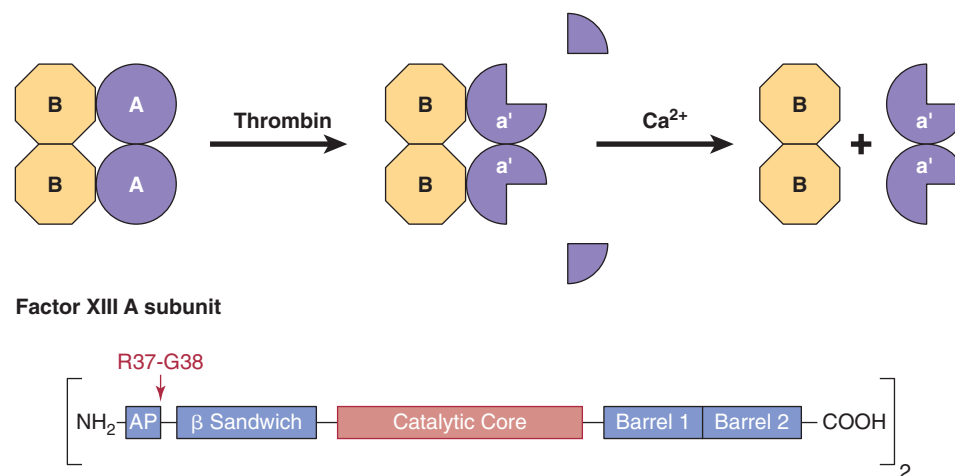

f0055

**Figure 34-10** Plasma factor XIII. Thrombin-catalyzed activation of plasma factor XIII ( $A_2B_2$ ; 320,000 Da) occurs in two steps. First, thrombin cleaves the R37-G38 bond. This releases the activation peptides (residues 1 to 37) from the A chains, producing the inactive intermediate  $a'_2B_2$ . In the second  $Ca^{2+}$ -dependent step, the B chains dissociate from the  $a'_2B_2$  intermediate, exposing the active site cysteine, Cys314, of the  $a'$  subunits. The enzyme  $a'_2$  catalyzes the formation of isopeptide bonds between glutamine residues and lysine residues of adjoining polypeptide chains.

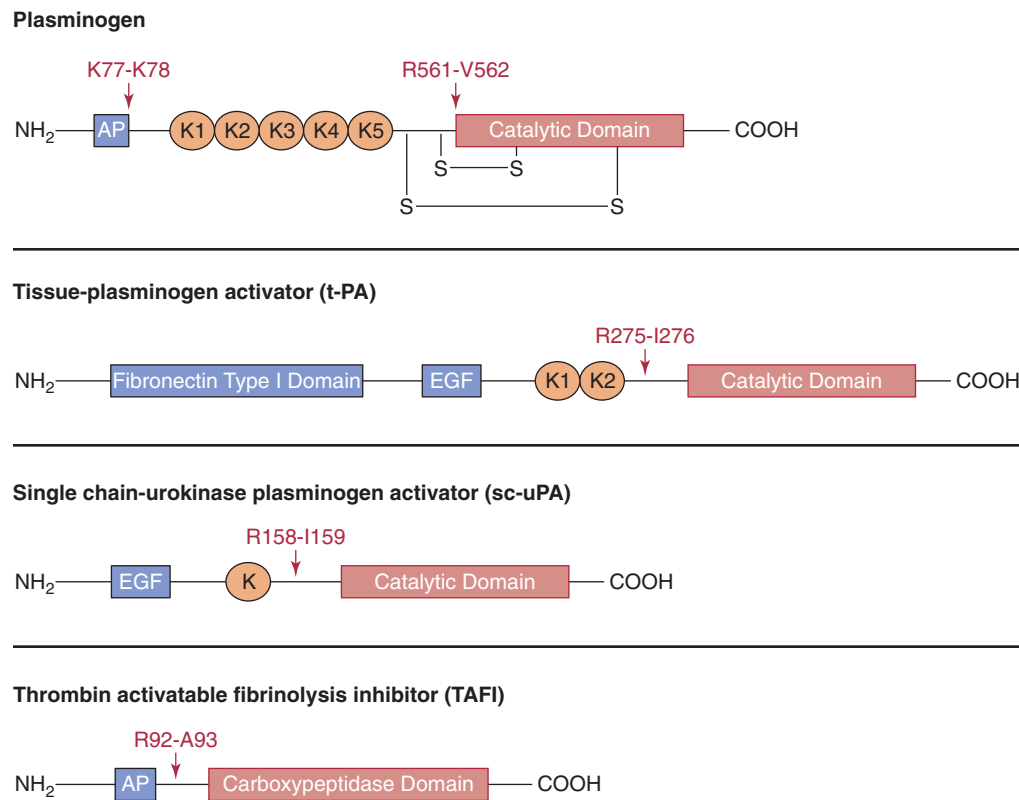

**Figure 34-11** A schematic representation of proteins of the fibrinolytic system. Plasminogen, tissue-type plasminogen activator, urokinase plasminogen activator, and thrombin-activatable fibrinolysis inhibitor are shown with their various domains depicted. Cleavage sites with the specific amino acid residues are shown. *AP*, Activation peptide; *K*, kringle domain; *EGF*, epidermal growth factor domain.

(1) the intrinsic activator system (analogous to the contact system of blood coagulation), (2) the extrinsic activators (t-PA and u-PA), and (3) the exogenous activation system involving pharmacologic agents (thrombolytic drugs). The ordinary path in vivo appears to be the extrinsic pathway, catalyzed by t-PA and u-PA. The extent to which the intrinsic pathway functions is the subject of debate.

Plasminogen activation is primarily inhibited by PAI-1, p0245 which targets u-PA and t-PA. PAI-1 also has a role in tissue remodeling by interfering with the vitronectin-dependent processes of cell adhesion and migration.<sup>160,161</sup> Congenital deficiency of PAI-1 is rare, with homozygous individuals displaying abnormal bleeding in response to trauma.<sup>161</sup>

**Table 34-3** Fibrinolytic Proteins, Inhibitors, and Receptors

Protein	M <sub>r</sub> (kD)	Plasma Concentration		Plasma t <sub>1/2</sub> (Days)	Clinical Phenotype*		Functional Classification
		(nmol/L)	(μg/mL)		H	T	
Plasminogen	88	2000	200	2.2			Proteinase zymogen
t-PA	70	0.07	0.005	0.00167			Proteinase zymogen
u-PA	54	0.04	0.002	0.00347			Proteinase zymogen
TAFI	58	75	4.5	0.00694		+	Carboxypeptidase
FSAP	64	190	12				Fibrinolytic zymogen
PAI-1	52	0.2	0.01	<0.00694	+		Proteinase inhibitor
PAI-2	47/60	<0.070	<0.005	–			Proteinase inhibitor
α-Antiplasmin	70	500	70	2.6	+		Proteinase inhibitor
u-PAR	55						Cell membrane receptor

*FSAP*, Factor VII-activating protease; *PAI*, plasminogen activator inhibitor; *TAFI*, thrombin-activatable fibrinolysis inhibitor; *t-PA*, tissue plasminogen activator; *u-PA*, urinary plasminogen activator (urokinase); *u-PAR*, urokinase-type plasminogen activator receptor.

\*Clinical phenotype, the expression of either hemorrhagic or thrombotic phenotype in deficient individuals: H, hemorrhagic disease/hemophilia; T, thrombotic disease/thrombophilia; +, presence of phenotype; –, absence of phenotype; ±, some individuals present with the phenotype and others do not.

p0250 In plasma or bound to fibrin in a blood clot, activation of plasminogen by either t-PA or u-PA converts Glu-plasminogen to Glu-plasmin. The two-chain enzyme can degrade fibrin, fibrinogen, and many other molecules. Glu-plasmin autolyzes by cleaving itself at Lys77 to generate Lys-plasmin.<sup>162,163</sup> Both Glu and Lys plasmin cleave after basic amino acid residues. The lysine analogues  $\epsilon$ -aminocaproic acid and tranexamic acid can compete with lysyl residues in proteins for binding to plasminogen and hence are inhibitors of fibrinolysis.<sup>164,165</sup>

p0255 Inhibition of plasmin by  $\alpha_2$ -antiplasmin is the primary route for regulation of plasmin's hemostatic function; suppression of plasmin activity beyond the locale of fibrin deposition is imperative if systemic fibrinogenolysis is to be prevented. Plasmin bound through its lysine binding sites to fibrin reacts more slowly with  $\alpha_2$ -antiplasmin than when it is free in solution. This differential reactivity effectively localizes plasmin activity to the fibrin clot.

s0130 **Tissue Plasminogen Activator.** t-PA is predominantly a p0260 product of endothelial cells,<sup>166-170</sup> but it is also produced by vascular smooth muscle cells,<sup>171</sup> neuronal cells,<sup>172</sup> megakaryocytes,<sup>173,174</sup> mast cells,<sup>175,176</sup> monocytes,<sup>177</sup> and fibroblasts.<sup>178</sup> Factors that regulate its secretion and release from the endothelium are important mediators of blood clotting or inflammation. These include thrombin, histamine, acetylcholine, bradykinin, epinephrine, interleukins, shear stress, and vaso-occlusion.<sup>179,180</sup> Functional t-PA concentrations have been reported to be less than 20 pmol/L, with most t-PA found in complex with PAI-1.<sup>181-183</sup> (The half-life in plasma is short; pharmacokinetic modeling indicates a half-life of 2.4 minutes for active t-PA and 5 minutes for the t-PA/PAI-1 complex.<sup>184,185</sup>) No cases of congenital deficiency of t-PA have been reported. Transgenic mice lacking a functional t-PA gene develop normally and display a normal basal hemostatic phenotype.<sup>186</sup> Mice in which both the t-PA and u-PA genes are disabled have shortened life spans and experience severe spontaneous thrombotic episodes.<sup>186,187</sup>

p0265 Regulation of t-PA activity in blood is accomplished by three primary mechanisms: (1) control of its catalytic potential by the fibrin dependence of plasminogen activation; (2) control of systemic levels of functional t-PA by the concerted processes of rapid t-PA removal by hepatic clearance and inhibition by the circulating serpin PAI-1; and (3) control of t-PA activity levels at the site of injury by the competing processes of increased t-PA secretion by traumatized and recruited cells versus PAI-1 release by activated platelets.

p0270 t-PA manifests its full fibrinolytic potential only when it is bound to fibrin.<sup>188-190</sup> This binding interaction aligns t-PA and plasminogen on the fibrin surface so that the catalytic efficiency of t-PA is enhanced several hundredfold. This is vital to the localization of plasmin generation at the site of fibrin deposition. Release of t-PA from the vessel wall is another important regulator of fibrinolysis.<sup>191,192</sup> The rate at which clots lyse depends on how rapidly t-PA is secreted by the relevant cells in the vicinity of an injury.<sup>193,194</sup> For example, activated platelets secrete serotonin, which can

induce endothelial cells to release t-PA; they also release PAI-1 from their alpha granules. Although only a fraction of this PAI-1 is in the active form, it functions to downregulate plasminogen activation.<sup>195,196</sup>

**Urokinase Plasminogen Activator.** u-PA was first identified s0135 in urine,<sup>197-199</sup> in which it is present at relatively high concentrations (40 to 80  $\mu\text{g/L}$  [800 to 1600 nmol/L]),<sup>199,200</sup> and in the media of cultured human kidney cells, endothelial cells, malignant cell lines, tumors, and plasma.<sup>201-204</sup> u-PA is a serine protease that is synthesized as a single-chain molecule, prourokinase, or single-chain u-PA (scu-PA). u-PA has a short half-life (approximately 5 minutes), and metabolism occurs in both the liver and the kidney. scu-PA has a very low level of proteolytic activity.<sup>205</sup>

Conversion of scu-PA to the more active two-chain form, p0280 tcu-PA, occurs principally through cleavage of the Lys158-Ile159 bond. The mechanism by which scu-PA is converted to tcu-PA remains poorly defined. It has been postulated that within a thrombus, t-PA initially activates plasminogen bound to fibrin to form plasmin and that it is this fibrin-localized plasmin that converts scu-PA to tcu-PA,<sup>206-208</sup> which results in amplification of the rate of plasmin formation. In addition, both kallikrein and factor XIIa<sup>209</sup> hydrolyze this bond. Other proteases that cleave the Lys158-Ile159 bond are cathepsin,<sup>210-213</sup> mast cell tryptase,<sup>214</sup> nerve growth factor- $\gamma$ ,<sup>215</sup> human T-cell serine proteinase-1,<sup>216</sup> and factor VII-activating protease.<sup>217</sup> A second, catalytically active form of two-chain urokinase, known as low-molecular-weight tcu-PA, is found in plasma when fibrinolysis is stimulated. It is formed by an additional plasmin cleavage at Lys135-Lys136. This cleavage produces a more efficient enzyme, and this low-molecular-weight form is used clinically for thrombolytic therapy. Another low-molecular-weight form of scu-PA arises from cleavage of the Glu143-Leu144 bond by the matrix metalloproteinases Pump 1 and metalloproteinase-3.<sup>218-220</sup> This form appears to be a better clot-lysing agent than low-molecular-weight tcu-PA.<sup>221</sup>

The main site of urokinase-driven plasminogen activation p0285 appears to be extravascular, where it has an important role in promoting degradation of the extracellular matrix by triggering the activation of plasminogen and, possibly, matrix metalloproteinases.<sup>222</sup> Regulation of urokinase is important for normal and pathologic processes, including embryogenesis, wound healing, tumor cell invasion, and metastasis.<sup>223-225</sup> Inhibitors of urokinase have been shown to suppress the growth of primary tumors and to interfere with metastasis of tumor cells.<sup>226-233</sup>

t-PA appears to be the primary plasminogen activator in p0290 the vasculature, with conversion of fibrin-localized scu-PA to tcu-PA, the latter acting as an amplifying rather than an initiating mechanism for plasmin formation.<sup>208,234</sup> Direct scu-PA activation of the Glu-plasminogen bound to COOH-terminal lysine residues found in partially proteolyzed fibrin has been proposed as contributing to clot lysis.<sup>235-237</sup> This catalytic role of scu-PA, although direct, still depends temporarily on t-PA-derived plasmin to create the circumstance

(plasmin-proteolyzed fibrin) under which it can contribute to overall fibrinolysis.

s0140 **Fibrinolysis Inhibitors**

s0145 **Plasminogen Activator Inhibitor-1.** PAI-1, the primary p0295 physiologic inhibitor of plasminogen activation in blood, targets u-PA and t-PA (Fig. 34-12). It also appears to have a role, independent of its antiproteolytic function, in tissue remodeling by interfering with the vitronectin-dependent processes of cell adhesion and migration. Congenital deficiency of PAI-1 is rare, with homozygous individuals displaying abnormal bleeding in response to trauma.<sup>238-242</sup> In the normal population, plasma PAI-1 concentrations vary over a 15-fold range (6 to 80 ng/mL; mean, 10 ng/mL [0.2 nmol/L])<sup>243,244</sup> and exhibit circadian variations.<sup>245</sup> Some of this variability stems from polymorphisms in the PAI-1 gene; however, a larger fraction of the variability appears to derive from the responsiveness of PAI-1 gene expression to a

wide variety of physiologic effectors and conditions as well as pharmacologic agents.<sup>246</sup> Higher levels of plasma PAI-1 delay fibrin removal by shortening the functional lifetime of plasminogen activators, delaying fibrinolysis.<sup>247</sup> The half-life of PAI-1 in blood is less than 10 minutes. Potential sites of constitutive PAI-1 synthesis in humans include the liver, spleen, adipose tissue, and cells of the vasculature, including endothelial cells, smooth muscle cells, macrophages, and megakaryocytes. A major fraction of PAI-1 in blood is present in platelets, apparently synthesized and stored in alpha granules during the maturation of megakaryocytes.<sup>248</sup> Although 75% to 80% of platelet PAI-1 is present in the latent form, there appears to be enough active PAI-1 released from platelets at sites of thrombus formation to contribute to the suppression of fibrinolysis.<sup>195,196,249</sup>

PAI-1 also appears to be involved in regulating cell adhesion and migration by a mechanism independent of its function as a protease inhibitor. Its high-affinity association

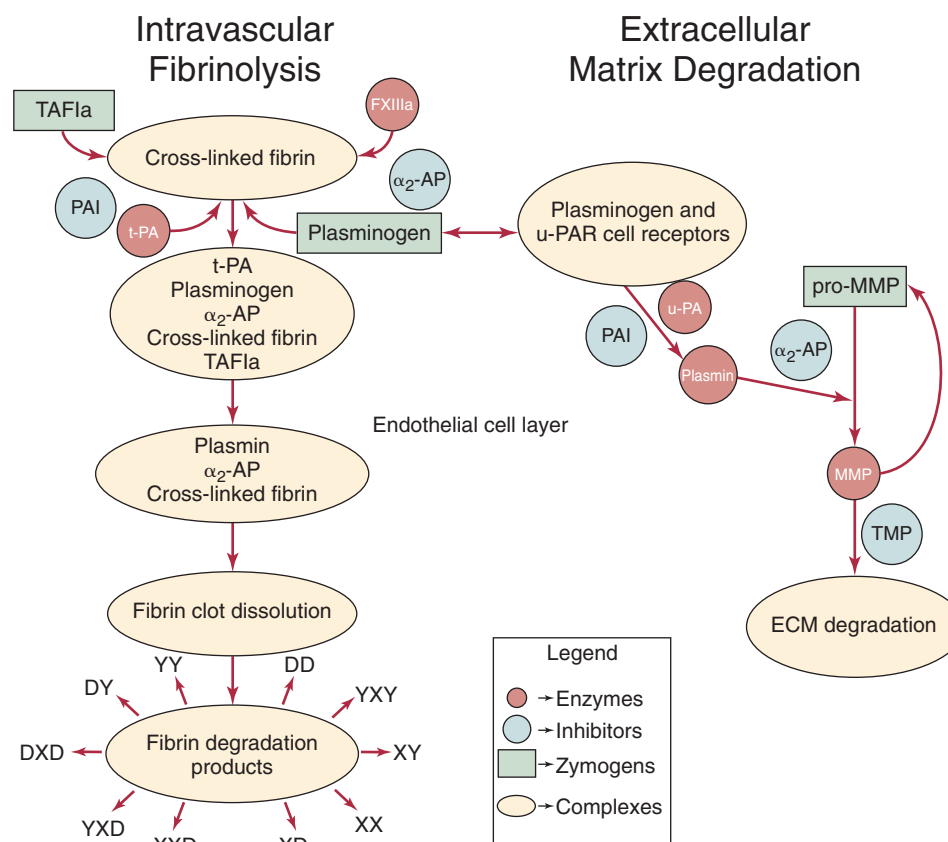

f0065

**Figure 34-12** Schematic of the dynamic interaction between the proteins and inhibitors of intravascular fibrinolysis and extracellular matrix degradation. Cross-linked fibrin formation (*left*) is integrated with fibrin clot dissolution and degradation of its products. Two pathways are shown: intravascular fibrinolysis and extracellular matrix degradation, separated by an endothelial cell layer. The enzymes, inhibitors, zymogens, and complexes are illustrated in simplified form to show this multicomponent process. Degradation of fibrin occurs by cleavage of plasmin at the D-E-D domains of fibrin polymers to yield a variety of polymers, as illustrated. Plasminogen can cross the endothelial cell layer and become converted to plasmin by urokinase (urinary plasminogen activator; u-PA) (*right*). Plasmin can convert latent matrix metalloproteinases (pro-MMP) to their active form (MMP). MMPs themselves can act in a positive feedback mechanism to convert pro-MMP to more MMP and ultimately degrade the extracellular matrix. Plasmin-mediated effects are inhibited by plasminogen activator inhibitor (PAI) and  $\alpha_2$ -antiplasmin. MMP-mediated effects are inhibited by tissue inhibitors (TMP).  $\alpha_2$ -AP,  $\alpha_2$ -Antitrypsin; ECM, extracellular matrix; t-PA, tissue plasminogen activator; TAFI, thrombin-activatable fibrinolysis inhibitor; u-PAR, u-PA receptor.

F

with the somatomedin B domain of vitronectin makes it an effective competitor with other ligands that also bind to vitronectin at this site, such as urokinase-type plasminogen activator receptor<sup>250-253</sup> and integrins, including  $\alpha_v\beta_3$ .<sup>254</sup> The ability to interfere with the binding of such cell-associated ligands to matrix-associated vitronectin suggests a role for PAI-1 as a regulator of the interaction of cells with the extracellular matrix.

s0150  **$\alpha_2$ -Antiplasmin.**  $\alpha_2$ -Antiplasmin (or  $\alpha_2$ -plasmin inhibitor) is  
p0305 the primary plasmin inhibitor<sup>255-258</sup> and thus is an important regulator of fibrinolysis (see Fig. 34-12). Congenital deficiency of  $\alpha_2$ -antiplasmin is rare, with homozygous individuals displaying a moderate to severe bleeding disorder.<sup>259</sup> The primary site of synthesis is the liver, although the kidney may be another contributing source<sup>260</sup>; its in vivo half-life is 2.6 days.<sup>261,262</sup>

s0155 **Thrombin-Activatable Fibrinolysis Inhibitor.** TAFI is a  
p0310 plasma procarboxypeptidase B synthesized in the liver and is thought to circulate in blood in complex with plasminogen.<sup>263</sup> Activation of TAFI yields an exopeptidase (TAFIa) with carboxypeptidase B substrate specificity. It catalyzes the removal of basic amino acids (arginines, lysines) from the COOH termini of polypeptides. Its primary physiologic activator appears to be the thrombin-TM complex, thus defining TAFIa as a coagulation-dependent activity.<sup>264</sup> The COOH-terminal lysyl residues of peptides produced during fibrin degradation are the primary substrates for TAFIa. The initial phase of plasmin proteolysis of fibrin produces products that amplify activation of plasminogen by t-PA. These fibrin degradation products contribute a positive feedback process that accelerates clot lysis. Removal of these terminal lysine residues by TAFIa reduces the number of plasminogen binding sites, thus downregulating the rate of plasmin generation and thereby the rate of clot lysis. As a result, TAFI/TAFIa functions as an antifibrinolytic factor by suppressing the positive feedback pathway of fibrinolysis.

p0315 Activation of TAFI in vitro is catalyzed by trypsin,<sup>263</sup> plasmin,<sup>263,265</sup> the plasmin-anionic glycosaminoglycan complex,<sup>265</sup>  $\alpha$ -thrombin,<sup>263,266</sup> the  $\alpha$ -thrombin-TM complex,<sup>264</sup> and the meizothrombin-TM complex.<sup>267</sup> The relative contributions of thrombin and plasmin to TAFI generation in vivo may be regulated by the availability of their respective cofactors at the site of vascular injury: cell-associated TM versus the extent of exposure of subendothelial extracellular matrix.

## s0160 CONNECTIVITY AND DYNAMICS OF BLOOD COAGULATION

p0320 In the healthy state, the three-compartment system consisting of vascular endothelium, blood, and extravascular tissue functions to maintain fluidity or to produce an integrated response to attenuate leakage of blood by localized activation at the site of vascular injury, with the

dimensions of the response relevant to the injury. The endothelial cell lining of the blood vessel is an active anticoagulant that secretes small molecules and enzymes to maintain blood platelets in a quiescent state. The endothelium also provides constituent anticoagulant proteins that inhibit the blood coagulation system. These vascular anticoagulant/fibrinolytic systems are both passive and dynamic and function in cooperation with plasma components. Blood supplies procoagulant and anticoagulant proteins through plasma, and platelets contribute to the coagulation reaction. When the endothelial lining is disrupted, the extravascular compartment and blood interact to rapidly produce a vigorous local coagulation response that attenuates blood loss and initiates the vascular repair process in four phases: initiation; propagation; termination; and elimination/fibrinolysis, which overlap.

### Initiation

Exposure of the subendothelial TF activates blood coagulation through binding to preexistent plasma factor VIIa, which is already present in its active form at 1% to 2% of the factor VII zymogen concentration.<sup>42,268</sup> Before binding to TF, the plasma serine protease factor VIIa is essentially inert from the catalytic perspective and therefore impervious to the abundant protease inhibitors in plasma.<sup>269</sup> Factor VII competes with factor VIIa for TF binding, thus serving as a negative regulator, buffering the overall reaction. Together, TF, factor VIIa, anionic membrane, and  $Ca^{2+}$  form the extrinsic tenase complex that activates the zymogens factor IX and factor X.<sup>270,271</sup> Factor X is the more efficient and abundant substrate. The TF-factor VIIa-factor Xa product complex is under tight supervision by TFPI.<sup>272,273</sup> TFPI is present in low abundance in blood (see Table 34-2) and can be released from the vasculature by the action of heparin.<sup>274</sup> If the initiating procoagulant stimulus is sufficient to overcome the level of this anticoagulant response, a threshold is exceeded and the downstream complexes can form and lead to an explosive burst of thrombin generation.

The small amounts of factor Xa produced that escape inhibition by TFPI and AT can activate small amounts of prothrombin to thrombin on an activated membrane surface.<sup>275</sup> Although this process is inefficient, this initial thrombin is essential to the acceleration of the process by serving as the activator for platelets through cleavage of the platelet-activated receptors 1 and 4 membrane proteins<sup>276</sup> and activation of the procofactors factor V and factor VIII.<sup>75</sup> Thrombin also activates factor XI to factor XIa,<sup>76</sup> thereby initiating the accessory pathway that enhances activation of factor IX.<sup>277</sup>

The initial thrombin begins activating factor XIII to factor XIIIa<sup>278</sup> and converts some fibrinogen to fibrin.<sup>151</sup> At this point, clot formation is observed, and all fibrinogen/fibrin (with some product already cross-linked) disappears from the fluid phase of the reaction. Thus, the "initial clot" is a mixture composed of fibrin and fibrinogen.

s0165

p0325

p0330

p0335

p0340

p0345

p0350

p0355

p0360

p0365

p0370

p0375

p0380

p0385

p0390

p0395

p0399

p0403

p0407

p0411

p0415

p0419

p0423

p0427

p0431

p0435

p0439

p0443

p0447

p0451

p0455

p0459

p0463

p0467

s0170 **Propagation**

p0340 Once the cofactor factor VIIIa is formed, it combines on activated platelets with the serine protease factor IXa that was generated by the factor VIIa-TF complex to form the intrinsic tenase complex. This complex is the major activator of factor X; it is 50 times more efficient than factor VIIa-TF in catalyzing the activation of factor X<sup>279,280</sup> and is not under the control of TFPI.<sup>281,282</sup> In the absence of factor VIII or factor IX, the intrinsic tenase complex cannot be assembled, and thus no amplification of factor Xa generation occurs. This is the principal defect observed in hemophilia A and hemophilia B.<sup>283,284</sup> The initial production of factor Xa by the TF-factor VIIa complex is inadequate to efficiently stem blood flow.

p0345 Factor Xa combines with factor Va on activated platelet membrane and other surfaces at specific receptor sites<sup>285</sup> to form the prothrombinase complex, the principal generator of thrombin. This process serves as a major amplification loop of blood coagulation. The factor IXa and factor Xa constituents of prothrombinase and the intrinsic tenase complex are protected from inhibition by antithrombin and other plasma inhibitors when they are in the complexed form.

p0350 When a sufficient stimulus is provided to overcome the antagonist inhibitor threshold, the accumulating mass of activated platelets will support increasing intrinsic and prothrombinase complex formation on their surfaces at specific platelet receptors and overwhelm the available local inhibitor concentrations. These platelet-bound catalysts execute the propagation phase of the reaction, during which massive amounts of thrombin are produced efficiently and continuously as long as more blood enters the wound site to resupply the procoagulant catalytic process.

s0175 **Termination**

p0355 Once flow has ceased because of the formation of a fibrin-platelet “dam,” the velocity of thrombin formation diminishes and the overwhelming concentration of inhibitors present in blood, including TFPI and antithrombin, heparin cofactor II,  $\alpha_2$ -macroglobulin,  $\alpha_1$ -antitrypsin, and protein C inhibitor, can “catch up” and inhibit the various proteases as they dissociate from their respective complexes. In the intact vasculature surrounding the growing thrombus, procoagulant enzymes and cofactors escaping the wound site are quenched rapidly under normal circumstances by the stoichiometric and dynamic inhibitory systems of blood in cooperation with elements of the vascular endothelium. The free serine proteases (thrombin, factor IXa, factor Xa) of the coagulation system in the plasma environment are rapidly inhibited by the surplus of antithrombin molecules, and the reaction is significantly accelerated by the interaction of antithrombin with heparan sulfate proteoglycans presented constitutively on the surface of vascular endothelial cells.

p0360 Any thrombin escaping from the wound site may bind resident TM constitutively present on vascular endothelial cells. When it is TM bound, thrombin is converted from a

procoagulant enzyme to an anticoagulant enzyme. The thrombin-TM-protein C complex activates protein C, which in turn downregulates the intrinsic tenase and prothrombinase procoagulants by cleaving factor VIIIa and factor Va. Rates of APC inactivation of factor Va and factor VIIIa are enhanced by protein S. TAFI is also activated by protein C and acts to prolong clot lysis (see other sources<sup>58,286</sup> for review). Cleavage of factor Va by APC and inhibition of thrombin generation also reduce thrombin-TM-mediated TAFI activation.<sup>287</sup>

When it is operating properly, this system of attenuation p0365 of blood leakage displays the appropriate level of procoagulant required to obstruct blood loss but is precluded from systemic activation of the coagulation system. The converse to hemostasis occurs when the damaging insult to the vasculature is internal to the vessel lumen.

**Elimination/Fibrinolysis**

s0180

The thrombus restricting blood flow is structurally composed p0370 of aggregated platelets and cross-linked fibrin. Other plasma proteins and blood cells are also trapped within the clot. Clot formation is integrated with clot dissolution by plasmin to maintain hemostatic balance. The lytic system has two roles: t-PA generates plasmin at the fibrin surface and governs fibrin homeostasis, whereas u-PA binds to a cellular u-PA receptor and generates pericellular plasmin, which plays an important role in tissue remodeling and cellular migration. The latter function is, to a great extent, mediated by plasmin activation of matrix metalloproteinases, which degrade the extracellular matrix. t-PA and u-PA are secreted by vascular endothelial cells and regulated by cellular cytokines and components produced during the clotting cascade, including thrombin.

In the absence of fibrin, t-PA is a poor enzyme. However, p0375 both t-PA and plasminogen bind to the fibrin surface with a resulting 100-fold enhancement of plasminogen activation. Thus, t-PA activation of fibrinolysis is primarily initiated by and localized to fibrin.<sup>188,190</sup> Plasmin digests fibrin in a pattern that produces a collection of degradation products,<sup>288</sup> including fragment X, fragment Y, and the core fragments D and E (see Fig. 34-12). The first step in degrading fibrin is removal of the  $\alpha$  chains to expose the coiled coils. As these coils are cleaved, different-sized fragments are released.<sup>289</sup> Fibrinogen is represented as a trinodular structure (D-E-D domains), with each E domain and D domain separated by a coiled coil domain. On formation of fibrin, the cross-links occur between alternating molecules of fibrin at the D domain (D=D). As plasmin degrades fibrin, various-sized fragments are released, the smallest of which is the D=D or D-dimer.<sup>290,291</sup> D-dimer has been identified in the blood of patients with various thrombotic or thrombolytic disorders.<sup>292</sup>

Fibrinolysis is regulated primarily by PAI-1, PAI-2,  $\alpha_2$ - p0380 antiplasmin, and TAFI. The antagonism between PAI-1 and the plasmin activators u-PA and t-PA provides a threshold response of the fibrinolytic process in much the same way as the procoagulant/anticoagulant balance provides an activation threshold for the clotting process.<sup>293</sup>

F

p0385 The elimination phase begins the process of tissue repair by dissolving the fibrin-platelet clot generated in the earlier phases of hemostasis. The damaged vascular tissue requires plasmin not only to clear the fibrin clot but also to initiate removal of damaged tissue so that cells can migrate into the injured area.<sup>294,295</sup> Plasmin activates a variety of matrix metalloproteinases that degrade subendothelial matrix components and extricate the damaged tissue.<sup>295,296</sup> These processes mark the beginnings of the final stages of the hemostatic response, repair, and regeneration process.

p0390 The importance of tight regulation of these processes is perhaps best illustrated by malfunctions of the hemostatic response. An inappropriate response can lead to one of two opposing but equally undesirable outcomes. Failure to form a sufficient hemostatic plug to arrest blood flow subsequent to vascular injury can result in pathologic hemorrhage. Excessive clot formation or failure to efficiently lyse a clot may result in thrombosis with consequent vascular obstruction. Under normal circumstances, the vascular endothelium together with the aforementioned positive and negative feedback loops within the procoagulant pathways prevents these negative outcomes by actively controlling the coagulation process until a triggering stimulus of sufficient magnitude threatens vascular integrity. Initiation of the procoagulant response also initiates the fibrinolytic response simultaneously with the repair and regeneration processes.

s0185 **BLOOD COAGULATION MONITORING**

p0395 Most clinical assays use fibrin clot formation as a means to assess hemostasis, for example, the prothrombin time (PT) and activated partial thromboplastin time (aPTT). In vitro,

formation of a visible fibrin clot occurs during the initiation phase of coagulation at only 3% to 5% of the total amount of thrombin produced.<sup>297,298</sup> The majority of thrombin (~95%) is generated after clot formation during the propagation phase,<sup>297</sup> during which most hemostatic and thrombotic physiology is occurring, and not captured by the fibrin clotting endpoints. Hemostasis is not synonymous with the clot endpoint of the reaction, and the latter is not a sufficient descriptor of the pathologic process associated with hemostatic disorders. The survival of mice<sup>299,300</sup> and male patients<sup>301,302</sup> with the afibrinogenemic genotypes also supports the concept that critically important events are taking place beyond the observation of initial fibrin formation. In this section, we review classic tests and newer assays used to evaluate blood coagulation.

**Plasma Clotting Tests**

s0190

Figure 34-13 represents a simplified continuity diagram for the coagulation system and interrogation of that system by common plasma assays, including the PT, aPTT, and thrombin time (TT). These tests are conducted with citrated plasma.

**Prothrombin Time**

s0195

The PT assay, developed by Quick in the 1930s,<sup>7</sup> is used to investigate the continuity of the extrinsic pathway of coagulation. The three main uses of the PT assay are monitoring of oral anticoagulant therapy, assessment of liver function in patients with severe liver disease, and screening for deficiencies in the extrinsic and common pathways. This assay

**Figure 34-13** Schematic of plasma coagulation tests. The prothrombin time evaluates the tissue factor (TF) or extrinsic activated pathway of blood coagulation. This test uses thromboplastin as an initiator of blood coagulation. The plasma test for evaluation of the intrinsic (contact or accessory) pathway is referred to as the partial thromboplastin time. This test uses a foreign surface (e.g., kaolin) as the activator of blood coagulation. The thrombin time, also known as the thrombin clotting time, specifically evaluates conversion of fibrinogen to fibrin through the action of thrombin. *HMWK*, High-molecular-weight kininogen; *PK*, prekallikrein.

f0070

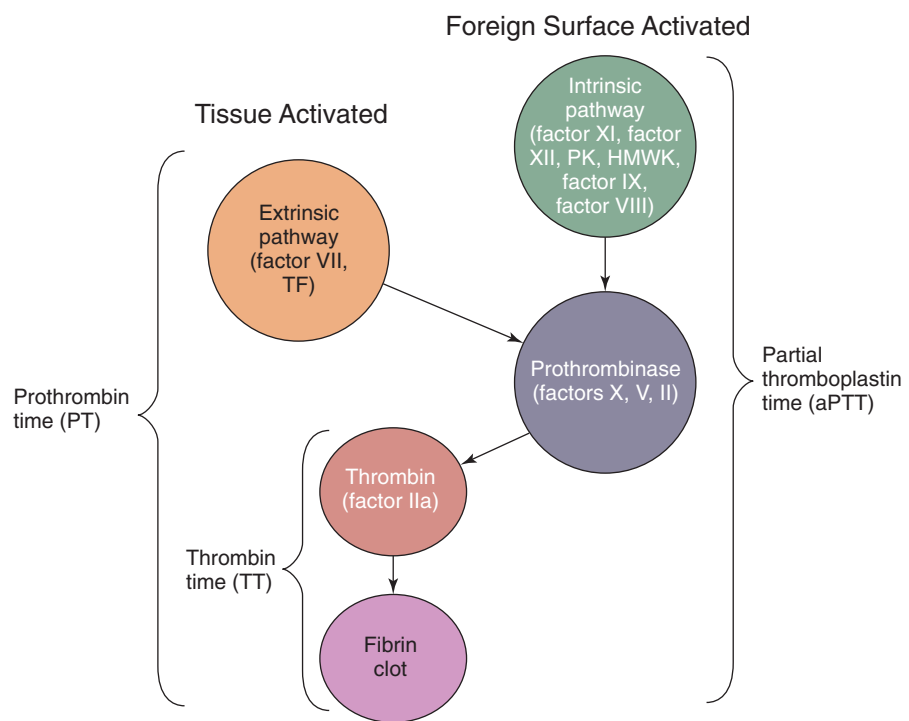

SECTION 7  
BLEEDING AND CLOTTING

F

depends on the infusion of  $\text{Ca}^{2+}$  and exogenous TF-lipid preparation (thromboplastin, recombinant or prepared from human placenta or rabbit brain) to citrated plasma. The intrinsic pathway contributions to coagulation in the PT assay are negligible because of the large amount of TF-lipid used. PT results are standardized by the international normalized ratio, which was adopted by the World Health Organization in 1983 to account for variations in the thromboplastin reagents.<sup>303</sup>

p0410 The TF pathway drives the formation of some of the reactive elements of the intrinsic pathway of coagulation, including factor XI, factor VIII, and factor IX. However, the contributions of these elements are not recognized in the PT assay because of the overwhelming amount of TF added to the reaction and the clot endpoint. This assay is most sensitive to factor II, factor V, factor VII, factor X, and fibrinogen; however, mild deficiencies in any of these factors can go undetected with the PT assay.

#### s0200 Activated Partial Thromboplastin Time

p0415 The continuity of the intrinsic (contact/accessory) pathway of coagulation is assessed by the aPTT, which involves adding phospholipid,  $\text{Ca}^{2+}$ , and a foreign “surface” (e.g., silica) to citrated plasma in the absence of TF.<sup>8</sup> This test evaluates the ability of the intrinsic pathway catalysts (i.e., factor XII, prekallikrein, HMWK, factor XI, factor VIII, and factor IX) and components of the common pathway (i.e., fibrinogen, prothrombin, factor V, and factor X) to produce a clot. The primary utility of the aPTT is that it provides identification of the congenital hemostatic defects associated with hemophilia A (factor VIII deficiency) and hemophilia B (factor IX deficiency). The aPTT is also used to monitor therapy with unfractionated heparin and to detect lupus anticoagulant.

#### s0205 Thrombin Time

p0420 The TT tests the ability of plasma fibrinogen to be transformed into fibrin to form a clot. The test detects direct inhibitors of thrombin or fibrin polymerization. The TT is particularly sensitive to heparin, fibrin degradation products, and hypofibrinogenemia or dysfibrinogenemia. Thus, this screening test is useful in evaluating a prolonged PT or aPTT by discriminating between a problem in thrombin generation and inhibition of thrombin activity. The TT is also used for monitoring the extent of the lytic state during thrombolytic therapy.

#### s0210 CAT Assays

p0425 An integrated view of the ability of plasma samples to generate thrombin on stimulation with either contact pathway activator or TF has more recently come into use. CAT (calibrated automated thrombogram) assays are conducted in a fluorometer with recalcified citrate plasma in the presence of a synthetic fluorescent substrate for thrombin.<sup>304-306</sup> During the assay, thrombin is produced and hydrolyzes the substrate to give a fluorescent signal that is continuously recorded, providing evaluation of the entire process of thrombin generation with respect to the initiation, propagation, and

termination phases of the reaction. As a consequence, the assay provides an integrated view of the reaction process. One caveat in interpretation, however, is that the fluorescent substrate used is also a competitive inhibitor of thrombin, and this interferes with the thrombin feedback reactions required to generate the catalysts of the propagation phase. However, these assays provide a great deal more information for the continuity of the reaction system than is available with clot-based assays.

#### Platelet Function Tests

s0215

Platelet function tests are used to aid diagnosis (e.g., platelets not functioning normally or thrombocytopenia), to predict risk (e.g., hemorrhage or thrombosis), and to monitor therapy (e.g., antiplatelet agents). The ideal platelet function test would be one that is able to perform accurately in all three areas. To date, there is still no reliable assay that can detect platelet hyperreactivity and thus identify a prothrombotic state.<sup>307</sup> As well, there is no one test that identifies all problems with platelet function, nor is there widespread agreement on which tests are best for each circumstance.<sup>307-310</sup> If platelets are not functioning normally or a decreased amount is present (thrombocytopenia), a patient is at an increased risk of excessive bleeding. A platelet count can be performed, but the overall function of the platelet is more difficult to measure. We discuss a few of these tests, including the bleeding time, the PFA-100, and platelet aggregometry.

#### Bleeding Time

s0220

The bleeding time involves placement of a blood pressure cuff on the patient's arm at standard pressure (40 mm Hg); then, with an automatic device, one or two short, shallow cuts or scratches are made on the inner forearm. The amount of time it takes for the bleeding to stop (platelet plug) is documented. If bleeding occurs for an extended time, the patient is considered to be at a higher risk for excessive bleeding during an invasive procedure such as surgery. The bleeding time procedure has fallen from favor in recent years. Many hospitals are no longer offering it, and several national organizations have issued position statements against its routine use as a presurgical screen. The bleeding time is not sensitive or specific, and it does not necessarily reflect the risk or severity of surgical bleeding. It is poorly reproducible, can be affected by aspirin ingestion and by the skill of the person performing the test, and frequently leaves small thin scars on the forearm.

#### PFA-100 (Platelet Function Analyzer–100)

s0225

More recently, the PFA-100 is being used in the hospital as the main testing device for platelet function screening. The test is performed by drawing a tube of blood from a vein in the arm, and then a portion of the blood is put into a test cartridge. The blood is then drawn by vacuum through a very thin glass tube that has been coated with collagen and with either epinephrine or adenosine diphosphate (ADP). The coating activates the platelets in the moving blood sample and promotes the platelets to adhere and aggregate. Clot

formation is measured as a closure time, which is defined as the time it takes for a clot to form inside the glass tube and to prevent further blood flow. The initial screen is done with collagen/epinephrine. If the closure time results are normal, it is unlikely that a platelet dysfunction exists. If the collagen/epinephrine test results are abnormal, a collagen/ADP test is run to confirm the abnormal results. If the results of both tests are abnormal, it is likely that the patient has a platelet dysfunction, and further testing for inherited or acquired bleeding disorders is indicated. If the collagen/ADP test result is normal, the abnormal collagen/epinephrine test response may be due to aspirin ingestion. This is the most frequently encountered abnormal collagen/epinephrine result as a single dose of aspirin can affect a person's platelet function for about 10 days. Although the PFA-100 has gained acceptance as a useful screen for platelet dysfunction, it has not been shown to be able to predict the likelihood that a patient will bleed excessively during surgery, and its full clinical utility has yet to be established.

s0230 **Platelet Aggregometry**

p0445 With platelet aggregometry, the laboratory can analyze how particular stimulators (agonists) affect platelets in a milieu of plasma (platelet-rich plasma) or whole blood. Aggregometry can be performed at low or high shear rates (velocity of a fluid expressed as inverse seconds). Light transmission aggregometry and whole-blood aggregometry are both performed by analyzers using a low-shear environment. The platelet function analyzer is one example of a high-shear system. Instruments providing both these environments are commercially available, making aggregometry readily accessible to a clinical laboratory. This test is used to diagnose inherited and acquired platelet function disorders. It is affected by aspirin and a variety of other drugs that alter platelet function.

s0235 **Other Platelet Function Tests**

p0450 There are many other platelet function tests that measure particular aspects of platelet aggregation or clot formation. Some are still being used only for research, whereas others are being used in hospitals for specific purposes. These tests have been reviewed<sup>310</sup> and include IMPACT, VerifyNOW, Plateletworks, platelet surface P-selectin, platelet surface

activated glycoprotein IIb/IIIa, leukocyte-platelet aggregates (flow cytometry), VASP phosphorylation state, platelet-derived microparticles, serum thromboxane B<sub>2</sub>, urinary 11-dehydrothromboxane B<sub>2</sub>, plasma sCD40L, plasma GPV, and alpha granule constituents in plasma (platelet factor 4 and  $\beta$ -thromboglobulin).

**Whole-Blood Assays**

s0240

There is renewed interest in "global coagulation testing" p0455 with methods enabling on-site measurements of coagulation that provide rapid and continuous information on coagulation. The use of whole blood gives a better picture of the situation in vivo because all blood components are allowed to interact during the test. The whole-blood, on-site assays in common use in surgery and cardiovascular percutaneous interventions are the activated clotting time (ACT) and thromboelastography.

**Activated Clotting Time**

s0245

The ACT, introduced by Hattersley in 1966,<sup>311</sup> is an adjusted p0460 aPTT test for samples of citrated whole blood. The ACT involves a proprietary device that includes a specialized tube containing activators of the intrinsic (contact) pathway. The ACT assay can evaluate the influence of coagulation inhibitors such as heparin and the direct thrombin inhibitors (e.g., bivalirudin [Angiomax]).<sup>312,313</sup> It is one of the most frequently performed coagulation assays and has shown utility as a point-of-care evaluation of the hemostatic response in surgical and interventional suites to control treatment with intravenous unfractionated heparin during vascular procedures.<sup>314</sup>

**Thromboelastography**

s0250

Thromboelastography uses technology that has existed for p0465 more than 40 years.<sup>315,316</sup> The modern iterations of the thromboelastograph are computerized, user-friendly devices that provide on-site evaluations of clotting performance and the potency of in situ fibrinolysis. These devices are viscometers that measure the increasing viscosity of blood during the coagulation process and produce a time-based record of the process. From the tracing obtained (Fig. 34-14), different semiquantitative parameters that evaluate the quality and

**Figure 34-14** Representation of a thromboelastographic tracing. Evaluation of the quality and timing of clot formation and lysis is illustrated in terms of semiquantitative parameters: R, the reaction time, estimates the time to initial clot formation; K and  $\alpha$  estimate the rate of fibrin formation and cross-linking; MA estimates the maximum amplitude of the fibrin clot and its strength; TMA calculates the time to MA. A<sub>30</sub> is the amplitude at 30 minutes.

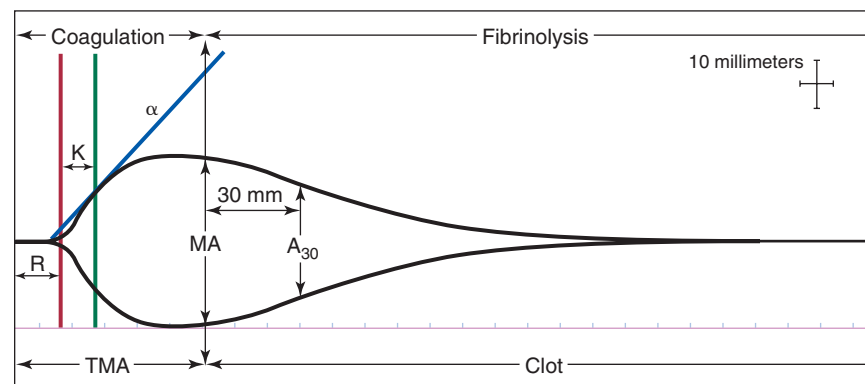

F

timing of clot formation and lysis are measured. The reaction time R estimates the time to clot (initial platelet-fibrin clot formation). K and  $\alpha$  are evaluators of the rate of clot buildup and cross-linking. The maximum amplitude is an estimate of the overall resistance or strength of the fibrin clot and depends on platelet number and function and fibrinogen levels. Protracted evaluations yield parameters (LY30, LY60, estimated percentage lysis) associated with clot lysis.

p0470 Like the aforementioned CAT technologies, thromboelastography involves analysis of whole-blood coagulation initiated by the contact pathway. This technology, however, is being expanded to define the mechanistic significance of the various thromboelastographic parameters by the development of methods that involve the use of either citrated whole blood that is recalcified or purely TF-dependent whole blood<sup>317</sup> containing a contact pathway suppressant.<sup>318</sup> Thromboelastography has been used to monitor blood coagulation during surgery,<sup>319</sup> trauma management,<sup>320</sup> and treatment with fibrinolytic agents.<sup>321-325</sup>

#### s0255 Future Coagulation Assays

p0475 The advent of new, direct-acting procoagulants and anticoagulants is leading to the development of new plasma-based and on-site whole-blood assays. These new assays have the potential to accurately report the quality of an anticoagulant response and will, it is hoped, mirror the phenotypic physiologic response to new, enzyme-specific inhibitors currently being developed in ongoing clinical trials. Some clinical studies have concluded that the currently available point-of-care technology may be less useful than is generally accepted,<sup>326-328</sup> thus suggesting the need for expanded new technologies with a focus on total thrombin generation in global assays. These new tests have the potential to be responsive to many of the newer anticoagulants being developed for therapeutic intervention. The ultimate utility of

these new assay technologies, however, is dependent on their established use and predictive qualities in the cardiology and surgical suites.

#### Acknowledgment

s0260

This chapter was supported in part by NIH HL 46703 to p0480 K.G.M. (Project 1) and K.B.Z. (Project 5) and by ARO W911NF-10-10376 to K.G.M. and K.B.Z.

#### SELECTED KEY REFERENCES

- Blomback B: Fibrinogen and fibrin—proteins with complex roles in hemostasis and thrombosis. *Thromb Res* 83:1–75, 1996.  
*A review of fibrinogen to fibrin formation and fibrinolysis.*
- Brummel-Ziedins KE, Pouliot RL, Mann KG: Thrombin generation: phenotypic quantitation. *J Thromb Haemost* 2:281–288, 2004.  
*An illustration of the heterogeneity of human blood response to tissue factor activation.*
- Colleen D, Lijnen HR: The tissue-type plasminogen activator story. *Arterioscler Thromb Vasc Biol* 29:1151–1155, 2009.  
*A review of the history of t-PA.*
- Davie EW: A brief historical review of the waterfall/cascade of blood coagulation. *J Biol Chem* 278:50819–50832, 2003.  
*The development of a “systems biology” approach to the mechanism of blood coagulation.*
- Esmon CT: The protein C pathway. *Chest* 124:S26–S32, 2003.  
*An important short review of the protein C anticoagulant pathway.*
- Mann KG: Thrombin generation in hemorrhage control and vascular occlusion. *Circulation* 124:225–235, 2011.  
*A review of thrombin generation in hemorrhage control and vascular occlusion.*
- Mann KG, Butenas S, Brummel KE: The dynamics of thrombin formation. *Arterioscler Thromb Vasc Biol* 23:17–25, 2003.  
*A review of the various phases of the blood coagulation process.*
- Mann KG, Nesheim ME, Church WR, Haley P, Krishnaswamy S: Surface-dependent reactions of the vitamin K–dependent enzyme complexes. *Blood* 76:1–16, 1990.  
*An important review of the significance of the assembled blood coagulation complexes to the rate of clot formation.*

The reference list can be found on the companion Expert Consult website p0485 at [www.expertconsult.com](http://www.expertconsult.com).

## REFERENCES

1. Mann KG: Normal hemostasis. In Kelley WN, editor: *Textbook of internal medicine*, Philadelphia, 1992, JB Lippincott, pp 1240–1245.
2. Brinkhous KM: A short history of hemophilia, with some comments on the word “hemophilia.” In Brinkhous KM, et al, editors: *Handbook of hemophilia*, New York, 1975, American Elsevier Publishing.
3. Ratnoff OD: The evolution of knowledge about hemostasis. In Ratnoff OD, et al, editors: *Disorders of hemostasis*, Philadelphia, 1996, WB Saunders, pp 1–22.
4. Owen CA, Jr: *A History of blood coagulation*, Rochester, MN, 2001, Mayo Foundation for Medical Education and Research.
5. Owen CA: Older concepts of blood coagulation. In Nichols WL, et al, editors: *A history of blood coagulation*. Rochester, 2001, Mayo Foundation for Medical Education and Research, pp 7–16.
6. Morawitz P: Die Chemie der Blutgerinnung. *Ergebn Physiol* 4:307, 1905.
7. Quick AJ: The prothrombin time in haemophilia and in obstructive jaundice. *J Biol Chem* 109:73–74, 1935.
8. Langdell RD, et al: Effect of antihemophilic factor on one-stage clotting tests: a presumptive test of hemophilia and a single one-stage anti-hemophilic factor assay procedure. *J Lab Clin Med* 41:7637–7647, 1953.
9. Girolami A, et al: Congenital bleeding disorders of the vitamin K-dependent clotting factors. *Vitam Horm* 78:281–374, 2008.
10. Stafford DW: The vitamin K cycle. *J Thromb Haemost* 3:1873–1878, 2005.
11. Nelsestuen GL, et al: Vitamin K-dependent proteins. *Vitam Horm* 58:355–389, 2000.
12. Stenflo J: Contributions of Gla and EGF-like domains to the function of vitamin K-dependent coagulation factors. *Crit Rev Eukaryot Gene Expr* 9:59–88, 1999.
13. Sunnerhagen M, et al: The relative orientation of Gla and EGF domains in coagulation factor X is altered by Ca<sup>2+</sup> binding to the first EGF domain. A combined NMR–small angle x-ray scattering study. *Biochemistry* 35:11547–11559, 1996.
14. Berkner KL: Vitamin K-dependent carboxylation. *Vitam Horm* 78:131–156, 2008.
15. Oldenburg J, et al: The vitamin K cycle. *Vitam Horm* 78:35–62, 2008.
16. Nelsestuen GL, et al: Interaction of vitamin K dependent proteins with membranes. *Biochemistry* 17:2134–2138, 1978.
17. Schwalbe RA, et al: Protein structural requirements and properties of membrane binding by  $\gamma$ -carboxyglutamic acid-containing plasma proteins and peptides. *J Biol Chem* 264:20288–20296, 1989.
18. Hirsh J: Optimal intensity and monitoring warfarin. *Am J Cardiol* 75:B39–B42, 1995.
19. Hirsh J, et al: Oral anticoagulants. Mechanism of action, clinical effectiveness, and optimal therapeutic range. *Chest* 108:S231–S246, 1995.
20. Schulman S, et al: Clinical factors influencing the sensitivity to warfarin when restarted after surgery. *J Intern Med* 263:412–419, 2008.
21. Cosgriff SW: The effectiveness of an oral vitamin K in controlling excessive hypothermia during anticoagulant therapy. *Ann Intern Med* 45:14–22, 1956.
22. Yeh C, et al: Oral direct factor Xa inhibitors. *Circ Res* 111:1069–1078, 2012.
23. Joseph DR, et al: Sex hormone-binding globulin, androgen-binding protein, and vitamin K-dependent protein S are homologous to laminin A, merosin, and *Drosophila crumbs* protein. *FASEB J* 6:2477–2481, 1992.
24. Prowse CV, et al: The isolation of a new warfarin-sensitive protein from bovine plasma. *Biochem Soc Trans* 5:255–256, 1977.
25. Kane WH, et al: Purification and characterization of human coagulation factor V. *J Biol Chem* 256:1002–1007, 1981.
26. Nesheim ME, et al: Isolation and characterization of single chain bovine factor V. *J Biol Chem* 254:508–517, 1979.
27. Bajzar L, et al: An antifibrinolytic mechanism describing the prothrombotic effect associated with factor V Leiden. *J Biol Chem* 271:22949–22952, 1996.
28. Katzmann JA, et al: Isolation of functional human coagulation factor V by using a hybridoma antibody. *Proc Natl Acad Sci U S A* 78:162–166, 1981.
29. Tracy PB, et al: Radioimmunoassay of factor V in human plasma and platelets. *Blood* 60:59–63, 1982.
30. Monkovic DD, et al: Activation of human factor V by factor Xa and thrombin. *Biochemistry* 29:1118–1128, 1990.
31. Mann KG, et al: Factor V: a combination of Dr Jekyll and Mr Hyde. *Blood* 101:20–30, 2003.
32. Esmon CT: The subunit structure of thrombin-activated factor V. Isolation of activated factor V, separation of subunits, and reconstitution of biological activity. *J Biol Chem* 254:964–973, 1979.
33. Mann KG, et al: Activated protein C cleavage of factor Va leads to dissociation of the A2 domain. *J Biol Chem* 272:20678–20683, 1997.
34. Dahlback B, et al: Familial thrombophilia due to a previously unrecognized mechanism characterized by poor anticoagulant response to activated protein C: prediction of a cofactor to activated protein C. *Proc Natl Acad Sci U S A* 90:1004–1008, 1993.
35. Bertina RM, et al: Mutation in blood coagulation factor V associated with resistance to activated protein C. *Nature* 369:64–67, 1994.
36. Leyte A, et al: The interaction between human blood-coagulation factor VIII and von Willebrand factor. Characterization of a high-affinity binding site on factor VIII. *Biochem J* 257:679–683, 1989.
37. Foster PA, et al: An immunogenic region within residues Val<sup>1670</sup>-Glu<sup>1684</sup> of the factor VIII light chain induces antibodies which inhibit binding of factor VIII to von Willebrand factor. *J Biol Chem* 263:5230–5234, 1988.
38. Butenas S, et al: Evaluation of the initiation phase of blood coagulation using ultrasensitive assays for serine proteases. *J Biol Chem* 272:21527–21533, 1997.
39. Jenny RJ, et al: Complete cDNA and derived amino acid sequence of human factor V. *Proc Natl Acad Sci U S A* 84:4846–4850, 1987.
40. Hoyer LW: Hemophilia A. *N Engl J Med* 330:38–47, 1994.
41. Nemerson Y, et al: Tissue factor accelerates the activation of coagulation factor VII: the role of a bifunctional coagulation cofactor. *Thromb Res* 40:351–358, 1985.
42. Nemerson Y: Tissue factor and hemostasis [published erratum appears in *Blood* 71:1178, 1988]. *Blood* 71:1–8, 1988.
43. Edgington TS, et al: The structural biology of expression and function of tissue factor. *Thromb Haemost* 66:67–79, 1991.
44. Nakagaki T, et al: Initiation of the extrinsic pathway of blood coagulation: evidence for the tissue factor dependent autoactivation of human coagulation factor VII. *Biochemistry* 30:10819–10824, 1991.
45. Toomey JR, et al: Targeted disruption of the murine tissue factor gene results in embryonic lethality. *Blood* 88:1583–1587, 1996.
46. Morel O, et al: Procoagulant microparticles: disrupting the vascular homeostasis equation? *Arterioscler Thromb Vasc Biol* 26:2594–2604, 2006.
47. Butenas S, et al: Tissue factor activity in whole blood. *Blood* 105:2764–2770, 2005.
48. Giesen PL, et al: Blood-borne tissue factor: another view of thrombosis. *Proc Natl Acad Sci U S A* 96:2311–2315, 1999.
49. Osterud B: The role of platelets in decrypting monocyte tissue factor. *Semin Hematol* 38:2–5, 2001.
50. Zillmann A, et al: Platelet-associated tissue factor contributes to the collagen-triggered activation of blood coagulation. *Biochem Biophys Res Commun* 281:603–609, 2001.
51. Esmon NL, et al: Isolation of a membrane-bound cofactor for thrombin-catalyzed activation of protein C. *J Biol Chem* 257:859–864, 1982.
52. Fukudome K, et al: Identification, cloning, and regulation of a novel endothelial cell protein C/activated protein C receptor. *J Biol Chem* 269:26486–26491, 1994.
53. Bangalore N, et al: High affinity binding sites for activated protein C and protein C on cultured human umbilical vein endothelial cells. Independent of protein S and distinct from known ligands. *Thromb Haemost* 72:465–474, 1994.

548.e2 SECTION 7 Bleeding and Clotting

54. Hofsteenge J, et al: Effect of thrombomodulin on the kinetics of the interaction of thrombin with substrates and inhibitors. *Biochem J* 237:243–251, 1986.
55. Bourin MC, et al: Functional domains of rabbit thrombomodulin. *Proc Natl Acad Sci U S A* 83:5924–5928, 1986.
56. Preissner KT, et al: Binding of thrombin to thrombomodulin accelerates inhibition of the enzyme by antithrombin III. Evidence for a heparin-independent mechanism. *Biochemistry* 26:2521–2528, 1987.
57. Kalafatis M, et al: The mechanism of inactivation of human factor V and human factor Va by activated protein C. *J Biol Chem* 269:31869–31880, 1994.
58. Nesheim M: Fibrinolysis and the plasma carboxypeptidase. *Curr Opin Hematol* 5:309–313, 1998.
59. Bajzar L, et al: Thrombin activatable fibrinolysis inhibitor: not just an inhibitor of fibrinolysis. *Crit Care Med* 32:S320–S324, 2004.
60. Mosnier LO, et al: Regulation of fibrinolysis by thrombin activatable fibrinolysis inhibitor, an unstable carboxypeptidase B that unites the pathways of coagulation and fibrinolysis. *Arterioscler Thromb Vasc Biol* 26:2445–2453, 2006.
61. Conway EM, et al: Tumor necrosis factor suppresses transcription of the thrombomodulin gene in endothelial cells. *Mol Cell Biol* 8:5588–5592, 1988.
62. Mann KG, et al: Surface-dependent reactions of the vitamin K-dependent enzyme complexes. *Blood* 76:1–16, 1990.
63. Hathaway WE, et al: Evidence for a new plasma thromboplastin factor. I. Case report, coagulation studies and physicochemical properties. *Blood* 26:521–532, 1965.
64. Colman RW, et al: Williams trait. Human kininogen deficiency with diminished levels of plasminogen proactivator and prekallikrein associated with abnormalities of the Hageman factor-dependent pathways. *J Clin Invest* 56:1650–1662, 1975.
65. Hoak JC, et al: Myocardial infarction associated with severe factor-XII deficiency. *Lancet* 2:884–886, 1966.
66. Hoyer LW: Factor VIII. In Colman RW, et al, editors: *Hemostasis and thrombosis: basic principles and clinical practice*, Philadelphia, 1987, JB Lippincott, pp 48–59.
67. Hoyer LW: Molecular pathology and immunology of factor VIII (hemophilia A and factor VIII inhibitors). *Hum Pathol* 18:153–161, 1987.
68. Biggs R, et al: Christmas disease: a condition previously mistaken for hemophilia. *Br Med J* 2:1384, 1952.
69. Tefler TP, et al: A “new” coagulation defect. *Br J Haematol* 2:308–312, 1956.
70. Owren PA, et al: Parahemophilia. *Arch Intern Med* 95:194–201, 1955.
71. Roberts HR, et al: *Inherited disorders of prothrombin conversion*, Philadelphia, 1987, JB Lippincott, pp 162–181.
72. Schmaier A, et al: Contact activation and its abnormalities. In Colman RW, et al, editors: *Hemostasis and thrombosis: basic principles and clinical practice*, Philadelphia, 1987, JB Lippincott, pp 18–33.
73. Rapaport SI, et al: The mode of inheritance of PTA deficiency: evidence for the existence of major PTA deficiency and minor PTA deficiency. *Blood* 18:149–155, 1961.
74. Sidi A, et al: Factor XI deficiency: detection and management during urological surgery. *J Urol* 119:528–530, 1978.
75. Lawson JH, et al: A model for the tissue factor pathway to thrombin. I. An empirical study. *J Biol Chem* 269:23357–23366, 1994.
76. Gailani D, et al: Factor XI activation in a revised model of blood coagulation. *Science* 253:909–912, 1991.
77. Schmaier AH: Assembly, activation, and physiologic influence of the plasma kallikrein/kinin system. *Int Immunopharmacol* 8:161–165, 2008.
78. Wiggins RC, et al: The autoactivation of rabbit Hageman factor. *J Exp Med* 150:1122–1133, 1979.
79. Silverberg M, et al: Autoactivation of human Hageman factor. Demonstration utilizing a synthetic substrate. *J Biol Chem* 255:7281–7286, 1980.
80. Mandle RJ, et al: Identification of prekallikrein and high-molecular-weight kininogen as a complex in human plasma. *Proc Natl Acad Sci U S A* 73:4179–4183, 1976.
81. Scott CF, et al: Cleavage of human high molecular weight kininogen markedly enhances its coagulant activity. Evidence that this molecule exists as a procofactor. *J Clin Invest* 73:954–962, 1984.
82. Scott CF, et al: Cleavage of human high molecular weight kininogen by factor XIa in vitro. Effect on structure and function. *J Biol Chem* 260:10856–10863, 1985.
83. Bone R: Sepsis and multiple organ failure: consensus and controversy. In Lamy M, et al, editors: *Mediators of sepsis*, New York, 1992, Springer-Verlag, pp 3–12.
84. Colman RW: Contact activation pathway: inflammatory, fibrinolytic, anticoagulant, antiadhesive and antiangiogenic activities. In Colman RW, et al, editors: *Hemostasis and thrombosis: basic principles and clinical practice*, Philadelphia, 2001, Lippincott Williams & Wilkins, pp 103–121.
85. Renne T, et al: Defective thrombus formation in mice lacking coagulation factor XII. *J Exp Med* 202:271–281, 2005.
86. Kleinschnitz C, et al: Targeting coagulation factor XII provides protection from pathological thrombosis in cerebral ischemia without interfering with hemostasis. *J Exp Med* 203:513–518, 2006.
87. Schousboe I: Pharmacological regulation of factor XII activation may be a new target to control pathological coagulation. *Biochem Pharmacol* 75:1007–1013, 2008.
88. Schmaier AH: Plasma contact activation: a revised hypothesis. *Biol Res* 31:251–262, 1998.
89. Rojkaer R, et al: Factor XII does not initiate prekallikrein activation on endothelial cells. *Thromb Haemost* 80:74–81, 1998.
90. Rosenberg RD, et al: The purification and mechanism of action of human antithrombin-heparin cofactor. *J Biol Chem* 248:6490–6505, 1973.
91. Perry DJ, et al: Molecular genetics of human antithrombin deficiency. *Hum Mutat* 7:7–22, 1996.
92. Harper PL, et al: The incidence of dysfunctional antithrombin variants: four cases in 210 patients with thromboembolic disease. *Br J Haematol* 77:360–364, 1991.
93. Olson ST, et al: Kinetic characterization of heparin-catalyzed and uncatalyzed inhibition of blood coagulation proteinases by antithrombin. *Methods Enzymol* 222:525–559, 1993.
94. Olson ST, et al: Demonstration of a two-step reaction mechanism for inhibition of alpha-thrombin by antithrombin III and identification of the step affected by heparin. *J Biol Chem* 257:14891–14895, 1982.
95. Casu B, et al: The structure of heparin oligosaccharide fragments with high anti-(factor Xa) activity containing the minimal antithrombin III-binding sequence. Chemical and <sup>13</sup>C nuclear-magnetic-resonance studies. *Biochem J* 197:599–609, 1981.
96. O'Reilly MS, et al: Antiangiogenic activity of the cleaved conformation of the serpin antithrombin. *Science* 285:1926–1928, 1999.
97. Olivera BM: E.E. Just Lecture, 1996. Conus venom peptides, receptor and ion channel targets, and drug design: 50 million years of neuropharmacology. *Mol Biol Cell* 8:2101–2109, 1997.
98. Broze GJ, Jr, et al: Heterogeneity of plasma tissue factor pathway inhibitor. *Blood Coagul Fibrinolysis* 5:551–559, 1994.
99. Novotny WF, et al: Purification and characterization of the lipoprotein-associated coagulation inhibitor from human plasma. *J Biol Chem* 264:18832–18837, 1989.
100. Bajaj MS, et al: Cultured normal human hepatocytes do not synthesize lipoprotein-associated coagulation inhibitor: evidence that endothelium is the principal site of its synthesis. *Proc Natl Acad Sci U S A* 87:8869–8873, 1990.
101. Sanders NL, et al: Inhibition of tissue factor/factor VIIa activity in plasma requires factor X and an additional plasma component. *Blood* 66:204–212, 1985.
102. Lesnik P, et al: Anticoagulant activity of tissue factor pathway inhibitor in human plasma is preferentially associated with dense subspecies of LDL and HDL and with Lp(a). *Arterioscler Thromb* 13:1066–1075, 1993.
103. Golino P, et al: Role of tissue factor pathway inhibitor in the regulation of tissue factor-dependent blood coagulation. *Cardiovasc Drug Rev* 20:67–80, 2002.

F

104. Kato H: Regulation of functions of vascular wall cells by tissue factor pathway inhibitor: basic and clinical aspects. *Arterioscler Thromb Vasc Biol* 22:539–548, 2002.
105. Broze GJ, Jr: Tissue factor pathway inhibitor. *Thromb Haemost* 74: 90–93, 1995.
106. Broze GJ, Jr, et al: Regulation of blood coagulation by protease inhibitors. In Stamatoyanopoulos G, et al, editors: *The molecular basis of blood diseases*. Philadelphia, 1994, WB Saunders, pp 629–656.
107. Sandset PM: Tissue factor pathway inhibitor (TFPI)—an update. *Haemostasis* 26(Suppl 4):154–165, 1996.
108. Lindahl AK: Tissue factor pathway inhibitor: from unknown coagulation inhibitor to major antithrombotic principle. *Cardiovasc Res* 33:286–291, 1997.
109. Schwartz AL, et al: Tissue factor pathway inhibitor. *Trends Cardiovasc Med* 7:234–239, 1997.
110. Huang ZF, et al: Tissue factor pathway inhibitor gene disruption produces intrauterine lethality in mice. *Blood* 90:944–951, 1997.
111. Chan JC, et al: Factor VII deficiency rescues the intrauterine lethality in mice associated with a tissue factor pathway inhibitor deficit. *J Clin Invest* 103:475–482, 1999.
112. Westrick RJ, et al: Deficiency of tissue factor pathway inhibitor promotes atherosclerosis and thrombosis in mice. *Circulation* 103:3044–3046, 2001.
113. Crawley JT, et al: The haemostatic role of tissue factor pathway inhibitor. *Arterioscler Thromb Vasc Biol* 28:233–242, 2008.
114. Tollefsen DM, et al: Activation of heparin cofactor II by dermatan sulfate. *J Biol Chem* 258:6713–6716, 1983.
115. Parker KA, et al: The protease specificity of heparin cofactor II. Inhibition of thrombin generated during coagulation. *J Biol Chem* 260:3501–3505, 1985.
116. Andrew M, et al: An anticoagulant dermatan sulfate proteoglycan circulates in the pregnant woman and her fetus. *J Clin Invest* 89:321–326, 1992.
117. Massouh M, et al: Heparin cofactor II activity in plasma during pregnancy and oral contraceptive use. *J Lab Clin Med* 114:697–699, 1989.
118. Liu L, et al: Inhibition of thrombin by antithrombin III and heparin cofactor II in vivo. *Thromb Haemost* 73:405–412, 1995.
119. Geiger M, et al: Protein C inhibitor (PCI). *Immunopharmacology* 32:53–56, 1996.
120. Seregini E, et al: Biochemical characteristics and recent biological knowledge on prostate-specific antigen. *Tumori* 82:72–77, 1996.
121. Laurell M, et al: Turnover of \*I-protein C inhibitor and \*I-alpha 1-antitrypsin and their complexes with activated protein C. *Blood* 76:2290–2295, 1990.
122. Heeb MJ, et al: Inhibition and complexation of activated protein C by two major inhibitors in plasma. *Blood* 73:446–454, 1989.
123. Hoogendoorn H, et al: A qualitative and quantitative analysis of the activation and inactivation of protein C in vivo in a primate model. *Blood* 75:2164–2171, 1990.
124. Ware AG, et al: Procedure for the quantitative determination of prothrombin concentration. *Am J Clin Pathol* 19:471–482, 1949.
125. Weiss HJ, et al: Role of shear rate and platelets in promoting fibrin formation on rabbit subendothelium. Studies utilizing patients with quantitative and qualitative platelet defects. *J Clin Invest* 78:1072–1082, 1986.
126. Griendling KK, et al: Endothelial control of the cardiovascular system: recent advances. *FASEB J* 10:283–292, 1996.
127. Rodgers GM: Endothelium and the regulation of hemostasis. In Lee GR, et al, editors: *Wintrobe's clinical hematology*, Baltimore, 1999, Williams & Wilkins, pp 765–773.
128. Colman RW, et al: Overview of hemostasis. In Colman RW, et al, editors: *Hemostasis and thrombosis: basic principles and clinical practice*, Philadelphia, 1994, JB Lippincott, pp 3–18.
129. Tracy PB, et al: Human prothrombinase complex assembly and function on isolated peripheral blood cell populations. *J Biol Chem* 260: 2119–2124, 1985.
130. Whelihan M, et al: Prothrombin activation in blood coagulation: the erythrocyte contribution to thrombin generation. *Blood* 120:3837–3845, 2012.
131. Tuszyński GP, et al: Factor XI antigen and activity in human platelets. *Blood* 59:1148–1156, 1982.
132. Bagdasarian A, et al: Subcellular localization and purification of platelet alpha<sub>1</sub>-antitrypsin. *Blood* 51:139–156, 1978.
133. Novotny WF, et al: Platelets secrete a coagulation inhibitor functionally and antigenically similar to the lipoprotein associated coagulation inhibitor. *Blood* 72:2020–2025, 1988.
134. Schwarz HP, et al: Identification and quantitation of protein S in human platelets. *Blood* 66:1452–1455, 1985.
135. McDonagh J, et al: Factor XIII in human plasma and platelets. *J Clin Invest* 48:940–946, 1969.
136. Erickson LA, et al: The primary plasminogen-activator inhibitors in endothelial cells, platelets, serum, and plasma are immunologically related. *Proc Natl Acad Sci U S A* 82:8710–8714, 1985.
137. Plow EF, et al: The presence and release of alpha<sub>2</sub>-antiplasmin from human platelets. *Blood* 58:1069–1074, 1981.
138. Holt JC, et al: Secretion of plasminogen by washed human platelets. *Circulation* 62:342, 1980.
139. Kruihof EK, et al: Studies on the release of a plasminogen activator inhibitor by human platelets. *Thromb Haemost* 55:201–205, 1986.
140. White JG: Views of the platelet cytoskeleton at rest and at work. *Ann N Y Acad Sci* 509:156–176, 1987.
141. Parise LV, et al: Platelets in hemostasis and thrombosis. In Foersten J, et al, editors: *Wintrobe's clinical hematology*, Baltimore, 1999, Williams & Wilkins, pp 661–683.
142. Hartwig JH: Platelet morphology. In Lescalzo J, et al, editors: *Thrombosis and hemorrhage*, Baltimore, 1998, Williams & Wilkins, pp 207–228.
143. Nurden AT: Human platelet membrane glycoproteins. In Bloom AL, et al, editors: *Hemostasis and thrombosis*, New York, 1994, Churchill Livingstone, pp 115–165.
144. Bouchard BA, et al: Effector cell protease receptor-1, a platelet activation-dependent membrane protein, regulates prothrombinase-catalyzed thrombin generation. *J Biol Chem* 272:9244–9251, 1997.
145. Altieri DC, et al: Protease-dependent T cell activation: ligation of effector cell protease receptor-1 (EPR-1) stimulates lymphocyte proliferation. *Cell Immunol* 155:372–383, 1994.
146. Altieri DC, et al: Identification of effector cell protease receptor-1. A leukocyte-distributed receptor for the serine protease factor Xa. *J Immunol* 145:246–253, 1990.
147. Altieri DC, et al: Sequential receptor cascade for coagulation proteins on monocytes. Constitutive biosynthesis and functional prothrombinase activity of a membrane form of factor V/Va. *J Biol Chem* 264:2969–2972, 1989.
148. Brass LF: Thrombin and platelet activation. *Chest* 124:S18–S25, 2003.
149. Blomback B: Fibrinogen: evolution of the structure-function concept. Keynote address at fibrinogen 2000 congress. *Ann N Y Acad Sci* 936:1–10, 2001.
150. Doolittle RF, et al: Crystal structure studies on fibrinogen and fibrin. *Ann N Y Acad Sci* 936:31–43, 2001.
151. Bailey K, et al: Action of thrombin in the clotting of fibrinogen. *Nature* 167:233–234, 1951.
152. Blomback B: Studies on the action of thrombotic enzymes on bovine fibrinogen as measured by N-terminal analysis. *Arkiv Kemi* 12:321, 2003.
153. Laki K, et al: On the solubility of fibrin clots. *Science* 108:280, 1948.
154. Lorand L: A study on the solubility of fibrin clots in urea. *Acta Physiol Acad Sci Hung* 1:192–196, 1948.
155. Lorand L: Factor XIII: structure, activation, and interactions with fibrinogen and fibrin. *Ann N Y Acad Sci* 936:291–311, 2001.
156. Marder VJ, et al: Plasmin degradation of cross-linked fibrin. *Ann N Y Acad Sci* 408:397–406, 1983.
157. Bachmann F: Plasminogen-plasmin enzyme system. In Colman RW, et al, editors: *Hemostasis and thrombosis: basic principles and clinical practice*, Philadelphia, 2001, Lippincott Williams & Wilkins, pp 275–320.

548.e4 SECTION 7 Bleeding and Clotting

158. Jenkins GR, et al: Regulation of plasminogen gene expression by interleukin-6. *Blood* 89:2394–2403, 1997.
159. Muller MF, et al: Electron microscopy of fine fibrin clots and fine and coarse fibrin films. Observations of fibers in cross-section and in deformed states. *J Mol Biol* 174:369–384, 1984.
160. Bugge TH, et al: Plasminogen deficiency causes severe thrombosis but is compatible with development and reproduction. *Genes Dev* 9:794–807, 1995.
161. Ploplis VA, et al: Effects of disruption of the plasminogen gene on thrombosis, growth, and health in mice. *Circulation* 92:2585–2593, 1995.
162. Violand BN, et al: Mechanism of the urokinase-catalyzed activation of human plasminogen. *J Biol Chem* 251:3906–3912, 1976.
163. Claeys H, et al: Physico-chemical and proenzyme properties of NH<sub>2</sub>-terminal glutamic acid and NH<sub>2</sub>-terminal lysine human plasminogen. Influence of 6-aminohexanoic acid. *Biochim Biophys Acta* 342:351–359, 1974.
164. Thorsen S, et al: Substrate composition and the effect of epsilon-aminocaproic acid on tissue plasminogen activator and urokinase-induced fibrinolysis. *Thromb Diath Haemorrh* 32:306–324, 1974.
165. Violand BN, et al: The effect of alpha-omega-amino acids on human plasminogen structure and activation. *J Biol Chem* 253:5395–5401, 1978.
166. Booyse FM, et al: Immunological identification and comparison of plasminogen activator forms in cultured normal human endothelial cells and smooth muscle cells. *Thromb Res* 24:495–504, 1981.
167. Goldsmith GH, Jr, et al: Studies on plasminogen activator and other proteases in subcultured human vascular cells. *Exp Mol Pathol* 35:257–264, 1981.
168. Levin EG, et al: Cultured bovine endothelial cells produce both urokinase and tissue-type plasminogen activators. *J Cell Biol* 94:631–636, 1982.
169. Levin EG: Latent tissue plasminogen activator produced by human endothelial cells in culture: evidence for an enzyme-inhibitor complex. *Proc Natl Acad Sci U S A* 80:6804–6808, 1983.
170. Allen RA, et al: Isolation and properties of human vascular plasminogen activator. *Thromb Haemost* 45:43–50, 1981.
171. Papadaki M, et al: Differential regulation of protease activated receptor-1 and tissue plasminogen activator expression by shear stress in vascular smooth muscle cells. *Circ Res* 83:1027–1034, 1998.
172. Wang Y, et al: Functional and morphologic evidence of the presence of tissue-plasminogen activator in vascular nerves: implications for a neurologic control of vessel wall fibrinolysis and rigidity. *J Neurosci Res* 53:443–453, 1998.
173. Brisson-Jeanneau C, et al: Presence of functionally active tissue plasminogen activator in human CFU-M derived megakaryocytes in vitro. *Fibrinolysis* 4:107–115, 1990.
174. Brisson-Jeanneau C, et al: Tissue-plasminogen activator RNA detected in megakaryocytes by in situ hybridization and biotinylated probe. *Histochemistry* 95:23–26, 1990.
175. Bankl HC, et al: Mast cells are augmented in deep vein thrombosis and express a profibrinolytic phenotype. *Hum Pathol* 30:188–194, 1999.
176. Sillaber C, et al: The mast cell as site of tissue-type plasminogen activator expression and fibrinolysis. *J Immunol* 162:1032–1041, 1999.
177. Hart PH, et al: Human monocytes can produce tissue-type plasminogen activator. *J Exp Med* 169:1509–1514, 1989.
178. Tyagi SC, et al: Stretch-induced membrane type metalloproteinase and tissue plasminogen activator in cardiac fibroblast cells. *J Cell Physiol* 176:374–382, 1998.
179. Collen D, et al: Tissue-type plasminogen activator. A review of its pharmacology and therapeutic use as a thrombolytic agent. *Drugs* 38:346–388, 1989.
180. Lucas RV, et al: The fibrinolytic system. Recent advances. *Cleve Clin J Med* 55:531–541, 1988.
181. Stalder M, et al: Release of vascular plasminogen activator (v-PA) after venous stasis: electrophoretic-zymographic analysis of free and complexed v-PA. *Br J Haematol* 61:169–176, 1985.
182. Booth NA, et al: Plasminogen activator in normal subjects after exercise and venous occlusion: t-PA circulates as complexes with C1-inhibitor and PAI-1. *Blood* 69:1600–1604, 1987.
183. Eitzman DT, et al: Plasminogen activator inhibitor-1. In Becker RC, editor: *Textbook of coronary thrombosis and thrombolysis*, Boston, 1997, Kluwer Academic, pp 65–78.
184. Chandler WL, et al: Clearance of tissue plasminogen activator (TPA) and TPA/plasminogen activator inhibitor type 1 (PAI-1) complex: relationship to elevated TPA antigen in patients with high PAI-1 activity levels. *Circulation* 96:761–768, 1997.
185. Garabedian HD, et al: Dose-dependent thrombolysis, pharmacokinetics and hemostatic effects of recombinant human tissue-type plasminogen activator for coronary thrombosis. *Am J Cardiol* 58:673–679, 1986.
186. Carmeliet P, et al: Physiological consequences of loss of plasminogen activator gene function in mice. *Nature* 368:419–424, 1994.
187. Carmeliet P, et al: Targeted gene manipulation and transfer of the plasminogen and coagulation systems in mice. *Fibrinolysis* 10:195–213, 1996.
188. Hoylaerts M, et al: Kinetics of the activation of plasminogen by human tissue plasminogen activator. Role of fibrin. *J Biol Chem* 257:2912–2919, 1982.
189. Zamarron C, et al: Kinetics of the activation of plasminogen by natural and recombinant tissue-type plasminogen activator. *J Biol Chem* 259:2080–2083, 1984.
190. Loscalzo J: Structural and kinetic comparison of recombinant human single- and two-chain tissue plasminogen activator. *J Clin Invest* 82:1391–1397, 1988.
191. Dichek D, et al: Thrombin regulation of mRNA levels of tissue plasminogen activator and plasminogen activator inhibitor-1 in cultured human umbilical vein endothelial cells. *Blood* 74:222–228, 1989.
192. Diamond SL, et al: Fluid flow stimulates tissue plasminogen activator secretion by cultured human endothelial cells. *Science* 243:1483–1485, 1989.
193. Emeis JJ: Regulation of the acute release of tissue-type plasminogen activator from the endothelium by coagulation activation products. *Ann N Y Acad Sci* 667:249–258, 1992.
194. Eijnden-Schrauwen Y, et al: Studies on the acute release of tissue-type plasminogen activator from human endothelial cells in vitro and in rats in vivo: evidence for a dynamic storage pool. *Blood* 85:3510–3517, 1995.
195. Fay WP, et al: Platelets inhibit fibrinolysis in vitro by both plasminogen activator inhibitor-1-dependent and -independent mechanisms. *Blood* 83:351–356, 1994.
196. Levi M, et al: Inhibition of plasminogen activator inhibitor-1 activity results in promotion of endogenous thrombolysis and inhibition of thrombus extension in models of experimental thrombosis. *Circulation* 85:305–312, 1992.
197. Steffens GJ, et al: The complete amino acid sequence of low molecular mass urokinase from human urine. *Hoppe Seylers Z Physiol Chem* 363:1043–1058, 1982.
198. Gunzler WA, et al: The primary structure of high molecular mass urokinase from human urine. The complete amino acid sequence of the A chain. *Hoppe Seylers Z Physiol Chem* 363:1155–1165, 1982.
199. Husain SS, et al: Purification and partial characterization of a single-chain high-molecular-weight form of urokinase from human urine. *Arch Biochem Biophys* 220:31–38, 1983.
200. Stump DC, et al: Urokinase-related proteins in human urine. Isolation and characterization of single-chain urokinase (pro-urokinase) and urokinase-inhibitor complex. *J Biol Chem* 261:1267–1273, 1986.
201. Shatos MA, et al: Alpha-thrombin stimulates urokinase production and DNA synthesis in cultured human cerebral microvascular endothelial cells. *Arterioscler Thromb Vasc Biol* 15:903–911, 1995.
202. van Hinsbergh VW: Regulation of the synthesis and secretion of plasminogen activators by endothelial cells. *Haemostasis* 18:307–327, 1988.
203. Wun TC, et al: Isolation and characterization of urokinase from human plasma. *J Biol Chem* 257:3276–3283, 1982.

F

204. Stump DC, et al: Purification and characterization of single-chain urokinase-type plasminogen activator from human cell cultures. *J Biol Chem* 261:1274–1278, 1986.
205. Collen D, et al: Activation of plasminogen by pro-urokinase. II. Kinetics. *J Biol Chem* 261:1259–1266, 1986.
206. Gurewich V, et al: Characterization of the intrinsic fibrinolytic properties of pro-urokinase through a study of plasmin-resistant mutant forms produced by site-specific mutagenesis of lysine<sup>158</sup>. *J Clin Invest* 82:1956–1962, 1988.
207. Gurewich V, et al: Fibrin binding and zymogenic properties of single-chain urokinase (pro-urokinase). *Semin Thromb Hemost* 13:146–151, 1987.
208. Pannell R, et al: Activation of plasminogen by single-chain urokinase or by two-chain urokinase—a demonstration that single-chain urokinase has a low catalytic activity (pro-urokinase). *Blood* 69:22–26, 1987.
209. Ichinose A, et al: The activation of pro-urokinase by plasma kallikrein and its inactivation by thrombin. *J Biol Chem* 261:3486–3489, 1986.
210. Kobayashi H, et al: Cathepsin B efficiently activates the soluble and the tumor cell receptor-bound form of the proenzyme urokinase-type plasminogen activator (Pro-uPA). *J Biol Chem* 266:5147–5152, 1991.
211. Nauland U, et al: Activation of thrombin-inactivated single-chain urokinase-type plasminogen activator by dipeptidyl peptidase I (cathepsin C). *Eur J Biochem* 223:497–501, 1994.
212. Schmitt M, et al: Effective activation of the proenzyme form of the urokinase-type plasminogen activator (pro-uPA) by the cysteine protease cathepsin L. *Fibrinolysis* 6 (Suppl 2):122, 1992.
213. Drag B, et al: Activation of pro-urokinase by cathepsin G in the presence of glucosaminoglycans. *Fibrinolysis* 8:192–199, 1994.
214. Stack MS, et al: Human mast cell tryptase activates single-chain urinary-type plasminogen activator (pro-urokinase). *J Biol Chem* 269:9416–9419, 1994.
215. Wolf BB, et al: Nerve growth factor- $\gamma$  activates soluble and receptor-bound single chain urokinase-type plasminogen activator. *J Biol Chem* 268:16327–16331, 1993.
216. Brunner G, et al: Activation of pro-urokinase by the human T cell-associated serine proteinase HuTSP-1. *FEBS Lett* 260:141–144, 1990.
217. Romisch J, et al: The FVII activating protease cleaves single-chain plasminogen activators. *Haemostasis* 29:292–299, 1999.
218. Marcotte PA, et al: The matrix metalloproteinase pump-1 catalyzes formation of low molecular weight (pro)urokinase in cultures of normal human kidney cells. *J Biol Chem* 267:13803–13806, 1992.
219. Ugwu F, et al: Proteolytic cleavage of urokinase-type plasminogen activator by stromelysin-1 (MMP-3). *Biochemistry* 37:7231–7236, 1998.
220. Orgel D, et al: The cleavage of pro-urokinase type plasminogen activator by stromelysin-1. *Clin Chem Lab Med* 36:697–702, 1998.
221. Collen D, et al: Basic and clinical aspects of fibrinolysis and thrombolysis. *Blood* 78:3114–3124, 1991.
222. Lijnen HR: Elements of the fibrinolytic system. *Ann N Y Acad Sci* 936:226–236, 2001.
223. Hansson GK: Inflammation, atherosclerosis, and coronary artery disease. *N Engl J Med* 352:1685–1695, 2005.
224. Blasi F: Proteolysis, cell adhesion, chemotaxis, and invasiveness are regulated by the u-PA-u-PAR-PAI-1 system. *Thromb Haemost* 82:298–304, 1999.
225. Quax PH, et al: Protein and messenger RNA levels of plasminogen activators and inhibitors analyzed in 22 human tumor cell lines. *Cancer Res* 50:1488–1494, 1990.
226. Evans DM, et al: Time and dose dependency of the suppression of pulmonary metastases of rat mammary cancer by amiloride. *Clin Exp Metastasis* 16:353–357, 1998.
227. Banerji A, et al: The field bean protease inhibitor has the potential to suppress B16F10 melanoma cell lung metastasis in mice. *Cancer Lett* 129:15–20, 1998.
228. Kobayashi H, et al: Inhibition of the metastasis of Lewis lung carcinoma by antibody against urokinase-type plasminogen activator in the experimental and spontaneous metastasis model. *Thromb Haemost* 71:474–480, 1994.
229. Xiao G, et al: Suppression of breast cancer growth and metastasis by a serpin myoepithelium-derived serine proteinase inhibitor expressed in the mammary myoepithelial cells. *Proc Natl Acad Sci U S A* 96:3700–3705, 1999.
230. Rabbani SA, et al: Prevention of prostate-cancer metastasis in vivo by a novel synthetic inhibitor of urokinase-type plasminogen activator (uPA). *Int J Cancer* 63:840–845, 1995.
231. Alonso DF, et al: Inhibition of mammary tumor cell adhesion, migration, and invasion by the selective synthetic urokinase inhibitor B428. *Anticancer Res* 18:4499–4504, 1998.
232. Alonso DF, et al: Effects of synthetic urokinase inhibitors on local invasion and metastasis in a murine mammary tumor model. *Breast Cancer Res Treat* 40:209–223, 1996.
233. Jankun J, et al: Inhibitors of urokinase reduce size of prostate cancer xenografts in severe combined immunodeficient mice. *Cancer Res* 57:559–563, 1997.
234. Robbins KC, et al: The peptide chains of human plasmin. Mechanism of activation of human plasminogen to plasmin. *J Biol Chem* 242:2333–2342, 1967.
235. Fleury V, et al: Mechanism of the enhanced intrinsic activity of single-chain urokinase-type plasminogen activator during ongoing fibrinolysis. *J Biol Chem* 268:18554–18559, 1993.
236. Longstaff C, et al: Kinetics of plasmin activation of single chain urinary-type plasminogen activator (scu-PA) and demonstration of a high affinity interaction between scu-PA and plasminogen. *J Biol Chem* 267:173–179, 1992.
237. Lenich C, et al: The effect of the carboxy-terminal lysine of urokinase on the catalysis of plasminogen activation. *Thromb Res* 64:69–80, 1991.
238. Dieval J, et al: A lifelong bleeding disorder associated with a deficiency of plasminogen activator inhibitor type 1. *Blood* 77:528–532, 1991.
239. Fay WP, et al: Brief report: complete deficiency of plasminogen-activator inhibitor type 1 due to a frame-shift mutation. *N Engl J Med* 327:1729–1733, 1992.
240. Lee MH, et al: Deficiency of plasma plasminogen activator inhibitor 1 results in hyperfibrinolytic bleeding. *Blood* 81:2357–2362, 1993.
241. Fay WP, et al: Human plasminogen activator inhibitor-1 (PAI-1) deficiency: characterization of a large kindred with a null mutation in the PAI-1 gene. *Blood* 90:204–208, 1997.
242. Minowa H, et al: Four cases of bleeding diathesis in children due to congenital plasminogen activator inhibitor-1 deficiency. *Haemostasis* 29:286–291, 1999.
243. Declerck PJ, et al: Purification and characterization of a plasminogen activator inhibitor 1 binding protein from human plasma. Identification as a multimeric form of S protein (vitronectin). *J Biol Chem* 263:15454–15461, 1988.
244. Declerck PJ, et al: Measurement of plasminogen activator inhibitor 1 in biologic fluids with a murine monoclonal antibody-based enzyme-linked immunosorbent assay. *Blood* 71:220–225, 1988.
245. Wiman B, et al: The fibrinolytic enzyme system and its role in the etiology of thromboembolic disease. *Semin Thromb Hemost* 16:207–216, 1990.
246. Stiko A, et al: Plasminogen activator inhibitors. In Colman RF, et al, editors: *Hemostasis and thrombosis: basic principles and clinical practice*, Philadelphia, 2002, Lippincott Williams & Wilkins, pp 355–365.
247. Huber K: Plasminogen activator inhibitor type-1 (part two): role for failure of thrombolytic therapy. PAI-1 resistance as a potential benefit for new fibrinolytic agents. *J Thromb Thrombolysis* 11:195–202, 2001.
248. Alessi MC, et al: Detection of plasminogen activator inhibitor-1 (PAI-1) mRNA in human megakaryocytes by in situ hybridization. *Thromb Haemost* 72:931–936, 1994.
249. Braaten JV, et al: Regulation of fibrinolysis by platelet-released plasminogen activator inhibitor 1: light scattering and ultrastructural examination of lysis of a model platelet-fibrin thrombus. *Blood* 81:1290–1299, 1993.
250. Kjoller L, et al: Plasminogen activator inhibitor-1 represses integrin- and vitronectin-mediated cell migration independently of its function as an inhibitor of plasminogen activation. *Exp Cell Res* 232:420–429, 1997.

548.e6 SECTION 7 Bleeding and Clotting

251. Waltz DA, et al: Plasmin and plasminogen activator inhibitor type 1 promote cellular motility by regulating the interaction between the urokinase receptor and vitronectin. *J Clin Invest* 100:58–67, 1997.
252. Kanse SM, et al: The urokinase receptor is a major vitronectin-binding protein on endothelial cells. *Exp Cell Res* 224:344–353, 1996.
253. Deng G, et al: Is plasminogen activator inhibitor-1 the molecular switch that governs urokinase receptor-mediated cell adhesion and release? *J Cell Biol* 134:1563–1571, 1996.
254. Stefansson S, et al: The serpin PAI-1 inhibits cell migration by blocking integrin  $\alpha_v\beta_3$  binding to vitronectin. *Nature* 383:441–443, 1996.
255. Collen D: Identification and some properties of a new fast-reacting plasmin inhibitor in human plasma. *Eur J Biochem* 69:209–216, 1976.
256. Mullertz S, et al: The primary inhibitor of plasmin in human plasma. *Biochem J* 159:545–553, 1976.
257. Moroi M, et al: Isolation and characterization of  $\alpha_2$ -plasmin inhibitor from human plasma. A novel proteinase inhibitor which inhibits activator-induced clot lysis. *J Biol Chem* 251:5956–5965, 1976.
258. Collen D, et al: Immunochemical distinction between antiplasmin and  $\alpha_1$ -antitrypsin. *Thromb Res* 7:245–249, 1975.
259. Favier R, et al: Congenital  $\alpha_2$ -plasmin inhibitor deficiencies: a review. *Br J Haematol* 114:4–10, 2001.
260. Menoud PA, et al: The kidney is a major site of  $\alpha_2$ -antiplasmin production. *J Clin Invest* 97:2478–2484, 1996.
261. Collen D, et al: Turnover of antiplasmin, the fast-acting plasmin inhibitor of plasma. *Blood* 53:313–324, 1979.
262. Mast AE, et al: Analysis of the plasma elimination kinetics and conformational stabilities of native, proteinase-complexed, and reactive site cleaved serpins: comparison of  $\alpha_1$ -proteinase inhibitor,  $\alpha_1$ -antichymotrypsin, antithrombin III,  $\alpha_2$ -antiplasmin, angiotensinogen, and ovalbumin. *Biochemistry* 30:1723–1730, 1991.
263. Eaton DL, et al: Isolation, molecular cloning, and partial characterization of a novel carboxypeptidase B from human plasma. *J Biol Chem* 266:21833–21838, 1991.
264. Bajzar L, et al: TAFI, or plasma procarboxypeptidase B, couples the coagulation and fibrinolytic cascades through the thrombin-thrombomodulin complex. *J Biol Chem* 271:16603–16608, 1996.
265. Mao SS, et al: Characterization of plasmin-mediated activation of plasma procarboxypeptidase B. Modulation by glycosaminoglycans. *J Biol Chem* 274:35046–35052, 1999.
266. Bajzar L, et al: Purification and characterization of TAFI, a thrombin-activable fibrinolysis inhibitor. *J Biol Chem* 270:14477–14484, 1995.
267. Cote HC, et al: Functional characterization of recombinant human meizothrombin and meizothrombin(desF1). Thrombomodulin-dependent activation of protein C and thrombin-activatable fibrinolysis inhibitor (TAFI), platelet aggregation, antithrombin-III inhibition. *J Biol Chem* 272:6194–6200, 1997.
268. Morrissey JH, et al: Quantitation of activated factor VII levels in plasma using a tissue factor mutant selectively deficient in promoting factor VII activation. *Blood* 81:734–744, 1993.
269. Komiyama Y, et al: Proteolytic activation of human factors IX and X by recombinant human factor VIIa: effects of calcium, phospholipids, and tissue factor. *Biochemistry* 29:9418–9425, 1990.
270. Jesty J, et al: Kinetics of the tissue factor-dependent activation of coagulation factors IX and X in a bovine plasma system. *J Biol Chem* 254:12337–12345, 1979.
271. Osterud B, et al: Activation of factor IX by the reaction product of tissue factor and factor VII: additional pathway for initiating blood coagulation. *Proc Natl Acad Sci U S A* 74:5260–5264, 1977.
272. Girard TJ, et al: Functional significance of the Kunitz-type inhibitory domains of lipoprotein-associated coagulation inhibitor. *Nature* 338:518–520, 1989.
273. Baglia FA, et al: Thrombin-mediated feedback activation of factor XI on the activated platelet surface is preferred over contact activation by factor XIIIa or factor XIa. *J Biol Chem* 275:20514–20519, 2000.
274. Novotny WF, et al: Purification and properties of heparin-releasable lipoprotein-associated coagulation inhibitor. *Blood* 78:394–400, 1991.
275. Rapaport SI: The extrinsic pathway inhibitor: a regulator of tissue factor-dependent blood coagulation. *Thromb Haemost* 66:6–15, 1991.
276. Coughlin SR, et al: Characterization of a functional thrombin receptor. Issues and opportunities. *J Clin Invest* 89:351–355, 1992.
277. Naito K, et al: Activation of human blood coagulation factor XI independent of factor XII. Factor XI is activated by thrombin and factor XIa in the presence of negatively charged surfaces. *J Biol Chem* 266:7353–7358, 1991.
278. Lorand L, et al: Activation of the fibrin-stabilizing factor of plasma by thrombin. *Arch Biochem Biophys* 105:58, 1964.
279. Lawson JH, et al: Cooperative activation of human factor IX by the human extrinsic pathway of blood coagulation. *J Biol Chem* 266:11317–11327, 1991.
280. Ahmad SS, et al: Components and assembly of the factor X activating complex. *Semin Thromb Hemost* 18:311–323, 1992.
281. van't Veer C, et al: Regulation of tissue factor initiated thrombin generation by the stoichiometric inhibitors tissue factor pathway inhibitor, antithrombin-III, and heparin cofactor-II. *J Biol Chem* 272:4367–4377, 1997.
282. Hockin MF, et al: A model for the stoichiometric regulation of blood coagulation. *J Biol Chem* 277:18322–18333, 2002.
283. Cawthorn KM, et al: Blood coagulation in hemophilia A and hemophilia C. *Blood* 91:4581–4592, 1998.
284. Butenas S, et al: Mechanism of factor VIIa-dependent coagulation in hemophilia blood. *Blood* 99:923–930, 2002.
285. Tracy PB, et al: Platelet factor Xa receptor. *Methods Enzymol* 215:329–360, 1992.
286. Bajzar L: Thrombin activatable fibrinolysis inhibitor and an antifibrinolytic pathway. *Arterioscler Thromb Vasc Biol* 20:2511–2518, 2000.
287. Bajzar L, et al: The profibrinolytic effect of activated protein C in clots formed from plasma is TAFI-dependent. *Blood* 88:2093–2100, 1996.
288. Francis CW, et al: Plasmic degradation of crosslinked fibrin. Characterization of new macromolecular soluble complexes and a model of their structure. *J Clin Invest* 66:1033–1043, 1980.
289. Gaffney PJ, et al: Subunit structure of the plasmin-induced degradation products of crosslinked fibrin. *Biochim Biophys Acta* 295:308–313, 1973.
290. Marder VJ: Physicochemical studies of intermediate and final products of plasmin digestion of human fibrinogen. *Thromb Diath Haemorrh* 80:187–195, 1970.
291. Larrieu MJ, et al: Effects of fibrinogen degradation products on platelets and coagulation. *Thromb Diath Haemorrh Suppl* 20:215–226, 1966.
292. Righini M, et al: D-Dimer for venous thromboembolism diagnosis: twenty years later. *J Thromb Haemost* 6:1059–1071, 2008.
293. Loskutoff DJ: Type 1 plasminogen activator inhibitor and its potential influence on thrombolytic therapy. *Semin Thromb Hemost* 14:100–109, 1988.
294. Collen D: Ham-Wasserman lecture: role of the plasminogen system in fibrin-homeostasis and tissue remodeling. *Hematology Am Soc Hematol Educ Program* 1–9, 2001.
295. Ellis V, et al: The urokinase receptor: involvement in cell surface proteolysis and cancer invasion. *Ann N Y Acad Sci* 667:13–31, 1992.
296. Lijnen HR: Plasmin and matrix metalloproteinases in vascular remodeling. *Thromb Haemost* 86:324–333, 2001.
297. Brummel KE, et al: Thrombin functions during tissue factor-induced blood coagulation. *Blood* 100:148–152, 2002.
298. Rand MD, et al: Blood clotting in minimally altered whole blood. *Blood* 88:3432–3445, 1996.
299. Suh TT, et al: Resolution of spontaneous bleeding events but failure of pregnancy in fibrinogen-deficient mice. *Genes Dev* 9:2020–2033, 1995.
300. Holmback K, et al: Impaired platelet aggregation and sustained bleeding in mice lacking the fibrinogen motif bound by integrin  $\alpha_{IIb}\beta_3$ . *EMBO J* 15:5760–5771, 1996.
301. Crabtree GR: The molecular biology of fibrinogen. In Stamatoyanopolous G, et al, editors: *The molecular basis of blood diseases*, Philadelphia, 1987, WB Saunders, pp 631–661.
302. Neerman-Arbez M, et al: Deletion of the fibrinogen [correction of fibrogen] alpha-chain gene (FGA) causes congenital afibrinogenemia. *J Clin Invest* 103:215–218, 1999.
303. WHO Expert Committee on Biological Standardization 33rd Report. *World Health Organ Tech Rep Ser* 167:81–105, 1983.

F

304. Hemker HC, et al: The calibrated automated thrombogram (CAT): a universal routine test for hyper- and hypocoagulability. *Pathophysiol Haemost Thromb* 32:249–253, 2002.
305. Hemker HC: Calibrated automated thrombinography (CAT). *Thromb Res* 115:255, 2005.
306. Ninivaggi M, et al: Whole-blood thrombin generation monitored with a calibrated automated thrombogram-based assay. *Clin Chem* 58:1252–1259, 2012.
307. Gorog DA, et al: Platelet function tests in clinical cardiology: unfulfilled expectations. *J Am Coll Cardiol* 61:2115–2129, 2013.
308. Janssen PW, et al: Platelet function testing and tailored antiplatelet therapy. *J Cardiovasc Transl Res* 6:316–328, 2013.
309. de Gaetano G, et al: Variability of platelet indices and function: acquired and genetic factors. *Handb Exp Pharmacol* 210:395–434, 2012.
310. Michelson AD: Platelet function testing in cardiovascular diseases. *Circulation* 110:e489–e493, 2004.
311. Hattersley PG: Activated coagulation time of whole blood. *JAMA* 196:436–440, 1966.
312. Zucker ML, et al: Sensitivity of a modified ACT test to levels of bivalirudin used during cardiac surgery. *J Extra Corpor Technol* 37:364–368, 2005.
313. Martin ME, et al: Argatroban for anticoagulation during cardiac surgery. *Eur J Haematol* 78:161–166, 2007.
314. Spinler SA, et al: Anticoagulation monitoring part 2: unfractionated heparin and low-molecular-weight heparin. *Ann Pharmacother* 39:1275–1285, 2005.
315. Hartert HS: Blutgerinnungsstudien mit der Thromboelastographie, einem neuen Untersuchungsverfahren. *Klin Wochenschr* 26:577–583, 1948.
316. Hartert HS: The physical and biological constants of thrombelastography. *Biorheology* 1:31–39, 1962.
317. Sorensen B, et al: Whole blood coagulation thromboelastographic profiles employing minimal tissue factor activation. *J Thromb Haemost* 1:551–558, 2003.
318. Mann KG, et al: Citrate blood: a century of artifact. *Blood* 108:459a, 2006.
319. Spiess BD, et al: Changes in transfusion therapy and reexploration rate after institution of a blood management program in cardiac surgical patients. *J Cardiothorac Vasc Anesth* 9:168–173, 1995.
320. Kaufmann CR, et al: Usefulness of thrombelastography in assessment of trauma patient coagulation. *J Trauma* 42:716–720, 1997.
321. Avidan MS, et al: The effects of aprotinin on thromboelastography with three different activators. *Anesthesiology* 95:1169–1174, 2001.
322. Grosse H, et al: The use of high dose aprotinin in liver transplantation: the influence on fibrinolysis and blood loss. *Thromb Res* 63:287–297, 1991.
323. Himmelreich G, et al: Different aprotinin applications influencing hemostatic changes in orthotopic liver transplantation. *Transplantation* 53:132–136, 1992.
324. Ramsay MA, et al: Intravascular thrombosis and thromboembolism during liver transplantation: antifibrinolytic therapy implicated? *Liver Transpl* 10:310–314, 2004.
325. Chavez JJ, et al: A novel thrombelastograph tissue factor/kaolin assay of activated clotting times for monitoring heparin anticoagulation during cardiopulmonary bypass. *Anesth Analg* 99:1290–1294, 2004.
326. Brener SJ, et al: Relationship between activated clotting time and ischemic or hemorrhagic complications: analysis of 4 recent randomized clinical trials of percutaneous coronary intervention. *Circulation* 110:994–998, 2004.
327. Tadros GM, et al: Intracoronary macrothrombus formation during percutaneous coronary intervention despite optimal activated clotting time using bivalirudin—a case report. *Angiology* 56:761–765, 2005.
328. Baird CW, et al: Anticoagulation and pediatric extracorporeal membrane oxygenation: impact of activated clotting time and heparin dose on survival. *Ann Thorac Surg* 83:912–919, 2007.