

ZnNi data

Keith Legg
ASETSDefense Technical Manager
Rowan Technology Group
Libertyville, IL

Report Documentation Page

Form Approved
OMB No. 0704-0188

Public reporting burden for the collection of information is estimated to average 1 hour per response, including the time for reviewing instructions, searching existing data sources, gathering and maintaining the data needed, and completing and reviewing the collection of information. Send comments regarding this burden estimate or any other aspect of this collection of information, including suggestions for reducing this burden, to Washington Headquarters Services, Directorate for Information Operations and Reports, 1215 Jefferson Davis Highway, Suite 1204, Arlington VA 22202-4302. Respondents should be aware that notwithstanding any other provision of law, no person shall be subject to a penalty for failing to comply with a collection of information if it does not display a currently valid OMB control number.

1. REPORT DATE NOV 2014		2. REPORT TYPE		3. DATES COVERED 00-00-2014 to 00-00-2014	
4. TITLE AND SUBTITLE ZnNi data				5a. CONTRACT NUMBER	
				5b. GRANT NUMBER	
				5c. PROGRAM ELEMENT NUMBER	
6. AUTHOR(S)				5d. PROJECT NUMBER	
				5e. TASK NUMBER	
				5f. WORK UNIT NUMBER	
7. PERFORMING ORGANIZATION NAME(S) AND ADDRESS(ES) Rowan Technology Group,1590 S. Milwaukee Avenue Ste 205,Libertyville,IL,60048				8. PERFORMING ORGANIZATION REPORT NUMBER	
9. SPONSORING/MONITORING AGENCY NAME(S) AND ADDRESS(ES)				10. SPONSOR/MONITOR'S ACRONYM(S)	
				11. SPONSOR/MONITOR'S REPORT NUMBER(S)	
12. DISTRIBUTION/AVAILABILITY STATEMENT Approved for public release; distribution unlimited					
13. SUPPLEMENTARY NOTES ASETSDefense 2014: Sustainable Surface Engineering for Aerospace and Defense, 18-20 Nov 2014, Fort Myer, VA.					
14. ABSTRACT					
15. SUBJECT TERMS					
16. SECURITY CLASSIFICATION OF:			17. LIMITATION OF ABSTRACT Same as Report (SAR)	18. NUMBER OF PAGES 13	19a. NAME OF RESPONSIBLE PERSON
a. REPORT unclassified	b. ABSTRACT unclassified	c. THIS PAGE unclassified			



Additional Corrosion Testing



Table 1 - Machine vs. Carbide Scribed Corrosion Test

Group No.	Test Specimen* Identification	Plating Material	Conversion Coat Type	Plating Thickness (mils)	Primer + Topcoat	Type of Scribe	Test Duration**	Test Results
1	BC1	Zn-Ni	TriCr	0.6 +/- 0.15	Yes	Machined Scribe	1000 hrs	PASS
	BC2	Zn-Ni	TriCr	0.7 +/- 0.1	Yes	Machined Scribe	1000 hrs	PASS
	BC3	Zn-Ni	TriCr	0.7 +/- 0.1	Yes	Machined Scribe	1000 hrs	PASS
2	HC1	Zn-Ni	TriCr	0.8 +/- 0.2	Yes	Machined Scribe	1000 hrs	PASS
	HC2	Zn-Ni	TriCr	0.8 +/- 0.1	Yes	Machined Scribe	1000 hrs	PASS
	HC3	Zn-Ni	TriCr	0.8 +/- 0.2	Yes	Machined Scribe	1000 hrs	PASS
3	HC4	Cd	HexCr	0.8 +/- 0.05	Yes	Machined Scribe	1000 hrs	PASS
	HC5	Cd	HexCr	0.7 +/- 0.1	Yes	Machined Scribe	1000 hrs	PASS
	HC6	Cd	HexCr	0.5 +/- 0.1	Yes	Machined Scribe	1000 hrs	PASS
4	BS1	Zn-Ni	TriCr	0.8 +/- 0.05	No	Machined Scribe	1000 hrs	PASS
	BS2	Zn-Ni	TriCr	0.7 +/- 0.05	No	Machined Scribe	1000 hrs	PASS
	BS3	Zn-Ni	TriCr	0.8 +/- 0.05	No	Machined Scribe	1000 hrs	PASS
5	HS1	Zn-Ni	TriCr	0.8 +/- 0.1	No	Machined Scribe	1000 hrs	PASS
	HS2	Zn-Ni	TriCr	0.8 +/- 0.05	No	Machined Scribe	1000 hrs	PASS
	HS3	Zn-Ni	TriCr	0.8 +/- 0.1	No	Machined Scribe	1000 hrs	PASS
6	HS4	Cd	HexCr	0.8 +/- 0.1	No	Machined Scribe	1000 hrs	FAIL
	HS5	Cd	HexCr	0.7 +/- 0.1	No	Machined Scribe	1000 hrs	FAIL
	HS6	Cd	HexCr	0.8 +/- 0.1	No	Machined Scribe	1000 hrs	FAIL
7	BS4	Zn-Ni	None	0.8 +/- 0.1	No	Machined Scribe	1000 hrs	FAIL ****
	BN1	Zn-Ni	None	0.7 +/- 0.1	No	No Scribe	1000 hrs	PASS ****

**** Group 7 test coupons were run without conversion coating and were not required to pass (i.e. information only)

BR&T ASTM B 117 Corrosion Test Results



Additional LHE Zn-Ni Hydrogen Re-Embrittlement Testing



- **The original LHE Zn-Ni test coupons failed due to poor plating in notch**
- **The reason for the poor plating on the original LHE Zn-Ni 1a.1 re-embrittlement coupons are as follows:**
 - **LHE Zn-Ni tank contamination**
 - **Spring '09 Lab analysis showed organic contamination**
 - **The PVC tank liner had begun to break down and had to be replaced in the Summer '09 with a more robust grade of PVC liner**
 - **Two years operating with new liner with no problems**
 - **Inconsistent plating in notch area**
 - **Specimens were chained in series when they were plated for the first series of tests**
 - **Now a fixture and conformal anode is used to ensure that there is uniform plating throughout the notch area per production process specification**
 - **Also circulation has been added around the notch area during plating**



Additional LHE Zn-Ni Hydrogen Re-Embrittlement Testing



Original Coupons Chained in Series

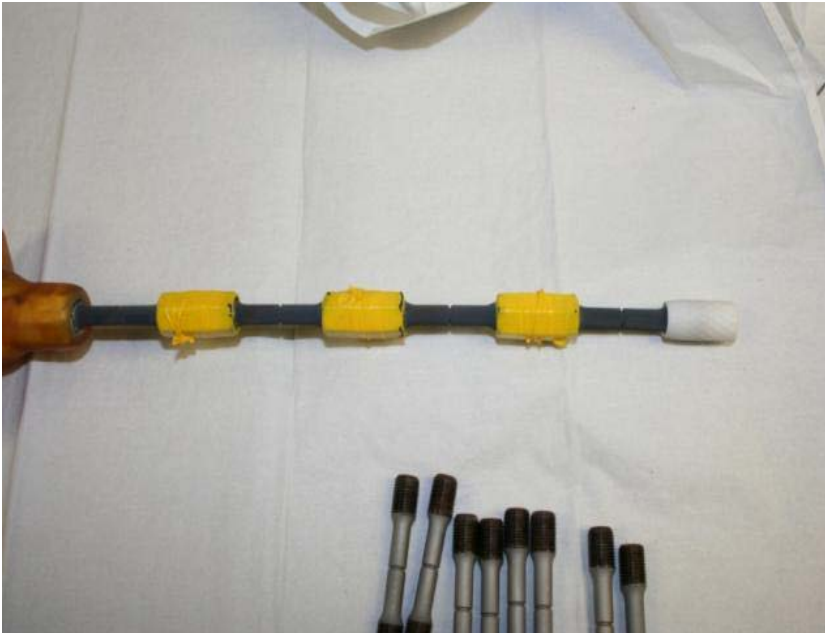

New fixture and Conformal Anode

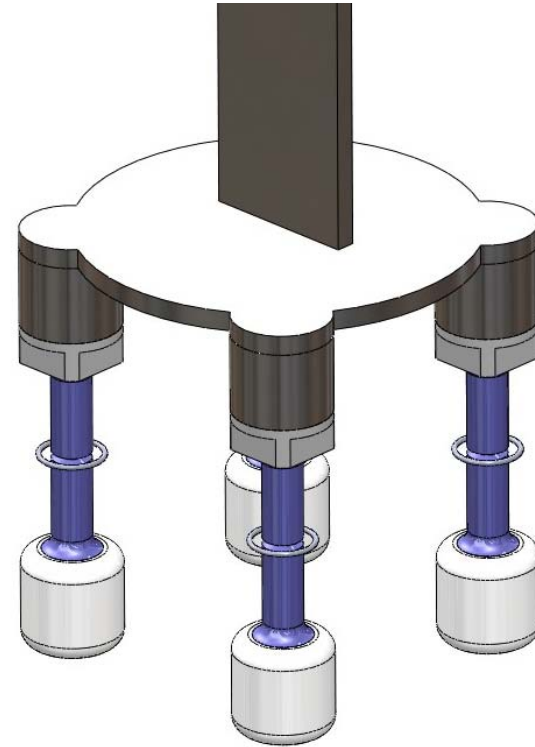



Additional LHE Zn-Ni Hydrogen Re-Embrittlement Testing

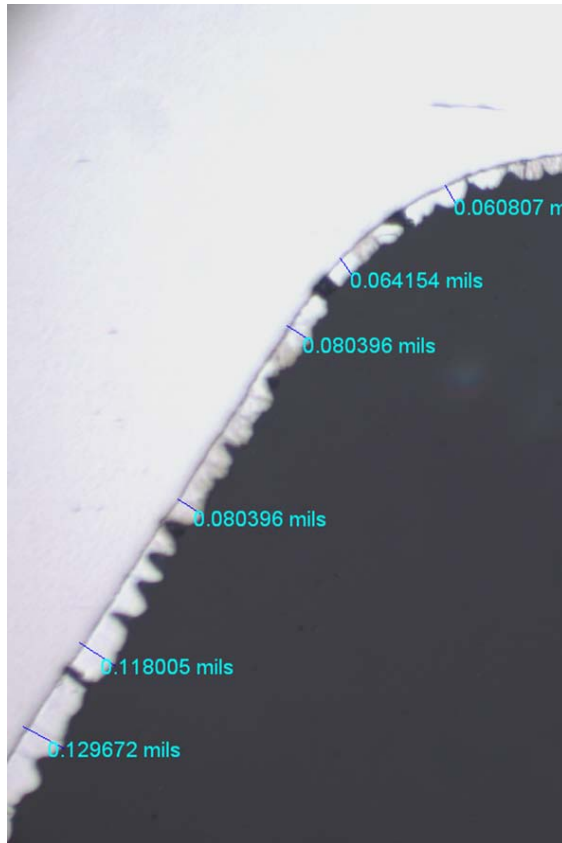

Current plating with fixture
and conformal anode

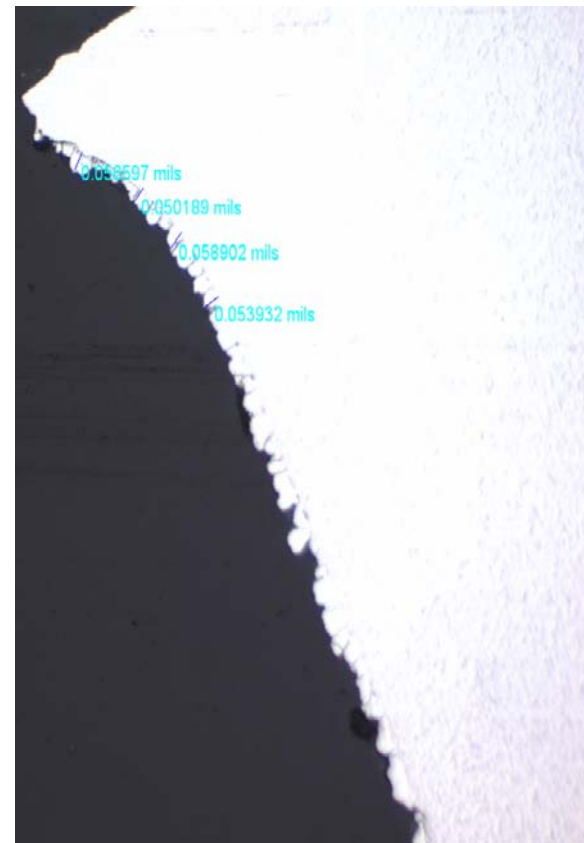

Contaminated plating
chained in series



Additional LHE Zn-Ni Hydrogen Re-Embrittlement Testing



- Additional, 3.5% salt water, re-embrittlement testing was conducted on LHE Zn-Ni plated coupons and they all passed the ASTM 519-06 150 hour requirement
- Cadmium and IVD Aluminum coupons were not re-tested because they are already approved for use on high strength steel

Re Embrittlement Test Matrix

Plating	Test Solution					
	Distilled Water @ Room Temp Tested 45% NFS for 150Hrs	3.5% Salt Water @ Room Temp Tested 45% NFS for 150Hrs	Dwg 9825019* Diluted Calla 296 @ Max Temp 180 °F Tested 75% NFS for 200Hrs	Dwg 9825019* Diluted Calla 602 LF Max Temp 160 °F Tested 75% NFS for 200Hrs	Concentrated Calla 296 @ Room Temp tested 45% NFS for 150Hrs	Concentrated Calla 602LF @ Room Temp tested 45% NFS for 150Hrs
LHE Zn-Ni	Passed	Passed	Passed	Passed	Passed	Passed
Cadmium	Passed	Failed	Passed	Passed	Passed	Passed
IVD	Failed	Failed	Not Tested	Not Tested	Not Tested	Not Tested

*The specimens were immersed in the cleaning compound at the manufacturer's maximum recommended temperature, and appropriate cleaning concentration, for 30 minutes. Removed. Air dried and loaded to 75% NFS for 200Hrs.

- In addition Boeing, Heroux have also carried out HE testing and passed, so that issue is resolved
- Concern over dezincification

Zinc-nickel alloy coatings



Corrosion protection and alloy composition / NO post-treatment

Zn/Ni in ISO 9227 NSS / time until red corrosion alloy

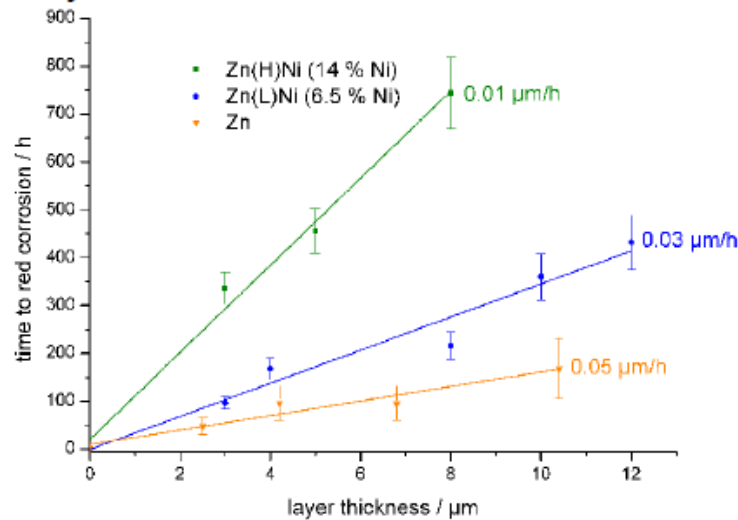

Ni₂Zn₁₁ γ-phase conc. vs Ni fraction in

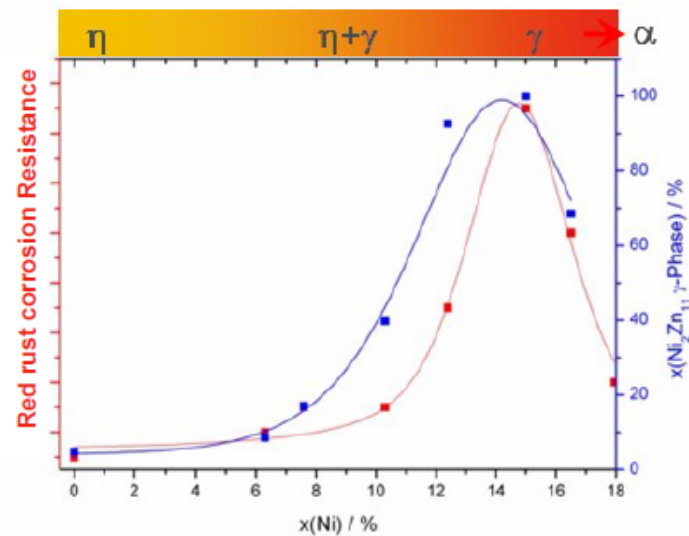

Best cathodic corrosion protection with γ-zinc-nickel alloy!

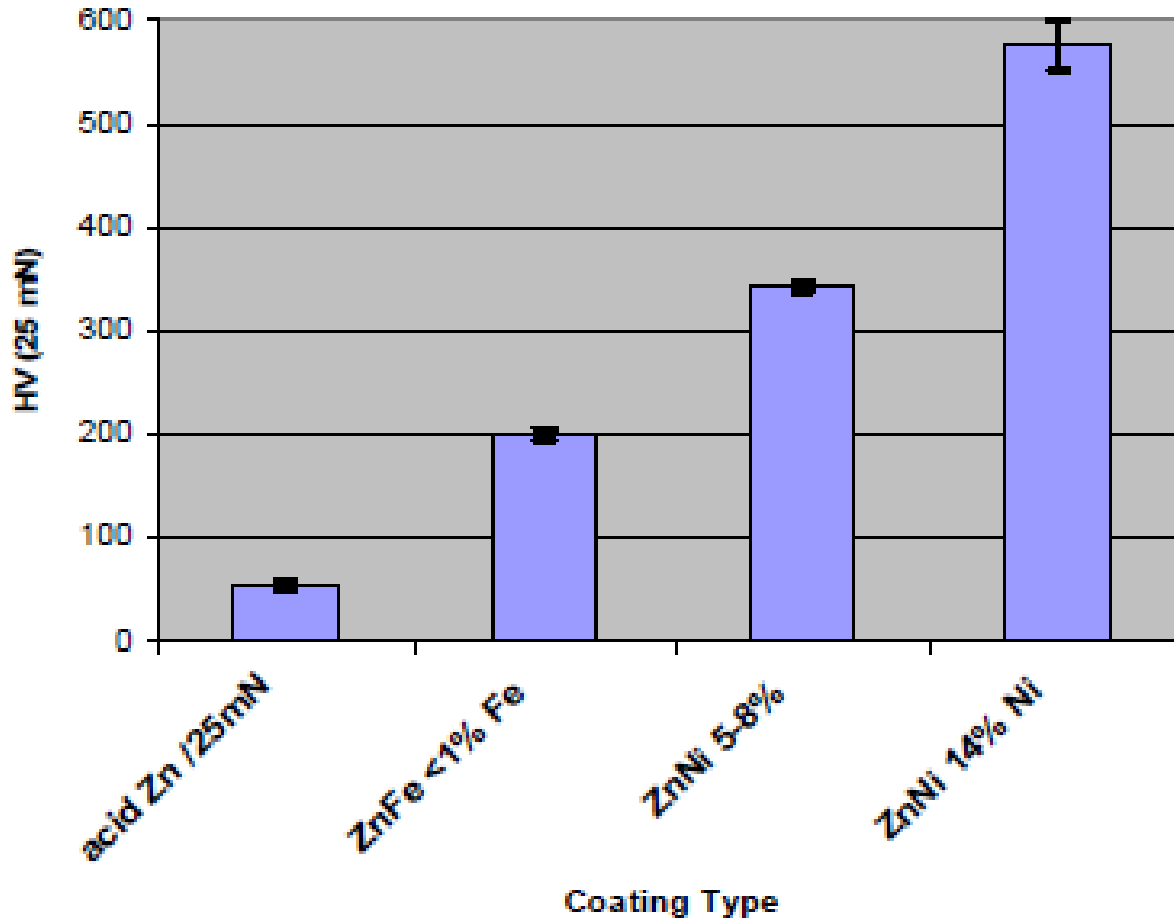

Not sure others have measured same hardness, but ZnNi is a lot harder than Cd



De-Zincification Testing

- Questions have been raised about the potential impact of dezincification of the Zn-Ni plating
- 417 SCMS/GUEA, BR&T and ES3 are currently reviewing past industry de-zincification studies
 - Initial findings show that the corrosion electro-potential is consistent throughout the corrosion process
- 417 SCMS/GUEA, BR&T and ES3 will identify any additional testing that might be required to address dezincification

I suspect it does not lose Zn because it is a true single phase alloy

Fatigue Test Results (Alkaline Zinc-Nickel, Phase IV)

- Nickel Alloy 718 Bolts – 3/8” diameter
Cd or Zn-Ni plated
- Test Nuts – MIL-STD-1312 uncoated
- Test setup – Per NASM1312-11
- Test parameters
 - Cycle = 24 Hz, RT
 - Tension-tension at 1090 lbs (low) and 10900 lbs (high)
- Requirement
 - Acceptance = 100000 cycles or meets statistical requirement
- Results – Alkaline Zn-Ni plating on fasteners performed comparable to Cd

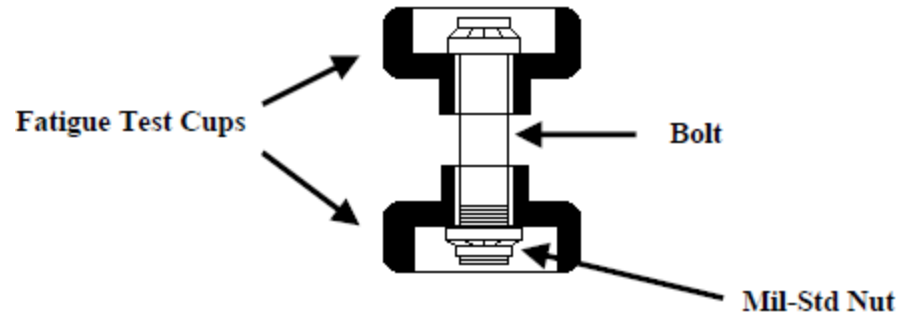

Part No.	Fastener Combination	
Bolt	BACB30US(Cadmium)	BACB30US(Zn-Ni)
Nut	MIL-STD-1312	MIL-STD-1312
Test No.	Cycles	Cycles
1	130000	119410
2	130000	130000
3	130000	130000
4	130000	130000
5	130000	130000
6	130000	108618
Average	130000	124671

Louie Tran, Boeing
ASETSDefense 2009

- Passes all testing as equal to or better than Cd
- Being adopted throughout world for aircraft structures and fasteners
- Not necessarily best for connectors
 - ❑ Non-Cr passivates have too high impedance
 - ❑ SERDP work on alternative passivate ongoing



Database



<http://db2.asetdefense.org/fmi/webd>

<http://db.asetdefense.org>



Main Menu

Documents Search

Reports, approvals, etc

Coatings Search

Coating alternatives, specs, etc.

Search instructions:

Choose Documents Search or Coatings Search.
Set up search using boxes at top of search page.
Mouse over cells for full content.
Click links for details.