

Advanced Underwater Port Security Systems

John Kloske
Department of Marine Science
University of South Florida
140 Seventh Ave. South
St. Petersburg, FL 33701
Phone (727) 553-1099 fax (727) 553-3967 email marops@marine.usf.edu

Scot T. Tripp
General Engineer
United States Coast Guard
Research and Development Center
Groton, CT 06340
Phone (860) 441-2680 fax (860) 441-2792 email strip@rdc.uscg.mil

Grant #: N00014-02-1-0859

LONG-TERM GOALS

To show the efficacy of autonomous underwater technologies in basic applications that are of value to the Coast Guard. Operationally, the AUV will scan harbor bottoms, seawalls and ship hulls.

OBJECTIVES

- Continuing testing of Laser Line Scanner (ROBOT) using the remotely controllable underwater vehicle ROVEX
- Modify the current Laser Line Scanning system to allow for the scanning of objects off to either side or above or below an AUV as required for scanning seawalls, harbor bottoms and ship hulls. The new Laser Line Scanning payload will be reduced in size to work with the new 12.75” diameter AUV.
- To integrate the ONR developed micro-modem with the AUV to facilitate the Coast Guards request that the AUV be able to operate under topside supervisory control. The use of these micro-modems will allow monitoring of the vehicle and the imaging sensor status via an acoustic communication link. Efforts will be made to electronically integrate the topside acoustic modem unit with the Ultra Short Baseline (USBL) acoustic tracking system thereby simplifying the required hardware, provide acoustic transmission synchronization and combine the modem and USBL topside transducers into to a single hydrophone assembly.
- Work with NUWC toward the potential integration of the Laser Line Scanner/Mobile Inspection Package (ONR Award # N00014-03-1-0708 and # N00014-03-1-0750) with their 12.75” AUV.
- Develop for the above Coast Guard tasks additional AUV mission control path planning routines, surface following controller and asynchronous data fusion software.
- Conduct demonstrations of the AUV as a sensor platform in support of the USCG Port security efforts.

Report Documentation Page

Form Approved
OMB No. 0704-0188

Public reporting burden for the collection of information is estimated to average 1 hour per response, including the time for reviewing instructions, searching existing data sources, gathering and maintaining the data needed, and completing and reviewing the collection of information. Send comments regarding this burden estimate or any other aspect of this collection of information, including suggestions for reducing this burden, to Washington Headquarters Services, Directorate for Information Operations and Reports, 1215 Jefferson Davis Highway, Suite 1204, Arlington VA 22202-4302. Respondents should be aware that notwithstanding any other provision of law, no person shall be subject to a penalty for failing to comply with a collection of information if it does not display a currently valid OMB control number.

1. REPORT DATE 30 SEP 2003		2. REPORT TYPE		3. DATES COVERED 00-00-2003 to 00-00-2003	
4. TITLE AND SUBTITLE Advanced Underwater Port Security Systems				5a. CONTRACT NUMBER	
				5b. GRANT NUMBER	
				5c. PROGRAM ELEMENT NUMBER	
6. AUTHOR(S)				5d. PROJECT NUMBER	
				5e. TASK NUMBER	
				5f. WORK UNIT NUMBER	
7. PERFORMING ORGANIZATION NAME(S) AND ADDRESS(ES) Department of Marine Science, University of South Florida,,140 Seventh Ave. South,,St. Petersburg,,FL, 33701				8. PERFORMING ORGANIZATION REPORT NUMBER	
9. SPONSORING/MONITORING AGENCY NAME(S) AND ADDRESS(ES)				10. SPONSOR/MONITOR'S ACRONYM(S)	
				11. SPONSOR/MONITOR'S REPORT NUMBER(S)	
12. DISTRIBUTION/AVAILABILITY STATEMENT Approved for public release; distribution unlimited					
13. SUPPLEMENTARY NOTES					
14. ABSTRACT To show the efficacy of autonomous underwater technologies in basic applications that are of value to the Coast Guard. Operationally, the AUV will scan harbor bottoms, seawalls and ship hulls.					
15. SUBJECT TERMS					
16. SECURITY CLASSIFICATION OF:			17. LIMITATION OF ABSTRACT	18. NUMBER OF PAGES	19a. NAME OF RESPONSIBLE PERSON
a. REPORT unclassified	b. ABSTRACT unclassified	c. THIS PAGE unclassified			

APPROACH

USF will design and fabricate a 12.75" diameter payload housing the ROBOT system (Figures 1, 2 and 3) that will adapt to ROVEX and will work as part of the Mobile Inspection Package (MIP). ROVEX will be used to operate the payload until USF takes delivery of the Bluefin 12 UUV in May of 2005 (ONR Awards N00014-02-1-0719 and N00014-02-1-0825).

USF will subcontract the acoustic modem work to Lee Freitag at WHOI and will work with Bluefin to integrate this system with their 12.75" UUV. USF will also coordinate with ORE for the integration of the micro-modem with their TrackPoint II USBL system.

USF will attend NUWC's 12.75" AUV design review and will meet with NUWC to work towards the integration of the MIP with NUWC's vehicle.

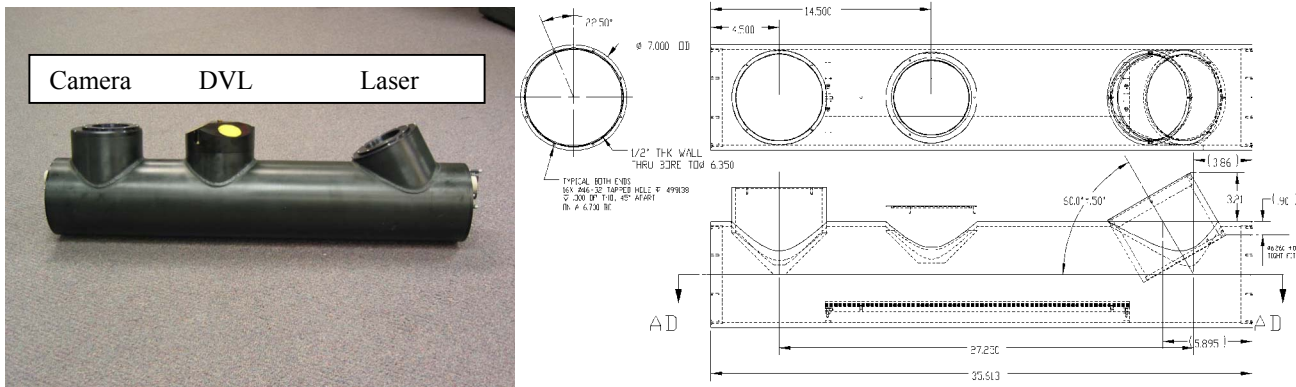

Figure 1. Laser Line Scanner (ROBOT) Pressure vessel for 12.75" payload

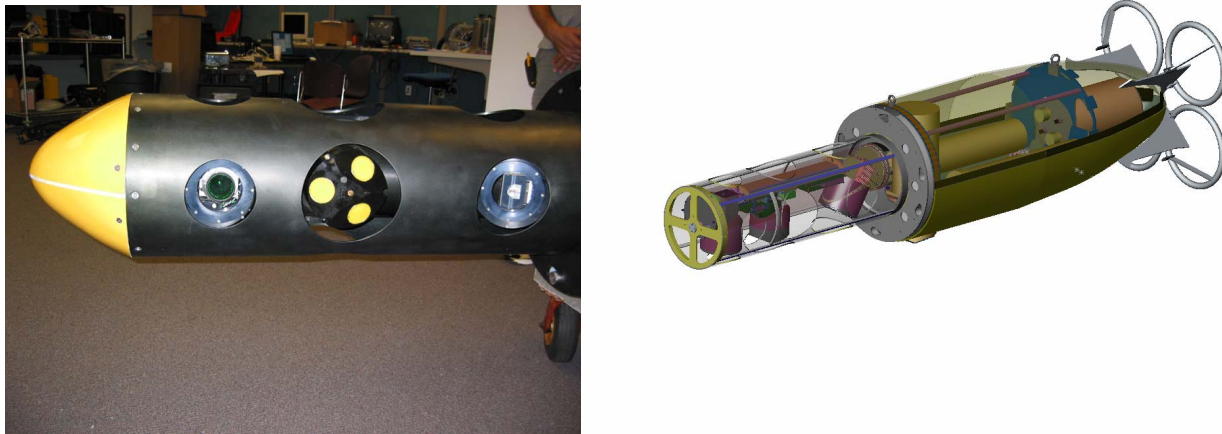

Figure 2. 12.75" Laser Line Scanner payload looking sideways and transparent drawing of payload installed on ROVEX looking down



Figure 3. 12.75" Laser Line Scanner payload installed on ROVEX during July operations

WORK COMPLETED

- Designed, fabricated, and integrated 12.75" diameter Laser Line Scanner payload to work with the MIP and with ROVEX (also ONR# N00014-03-1-0708). The payload was designed to look up, down and sideways to scan ship hulls, seafloors and seawalls. The payload was built to work with the new 12.75" standard vehicles.
- Micro-modem design has been subcontracted and work is proceeding towards completion.
- Attended NUWC 12.75" vehicle design review meeting.
- Conducted four one-week operations with the MIP configured with the Laser Line Scanning and ISS laser scaling camera payload during the months of February, April, July and September of 2003. Operations were conducted in the Port of St. Petersburg and just north of the ship channel outside of Tampa Bay to work in real world conditions. The February operations were conducted with the assistance of the local Coast Guard Aids to Navigation group and utilizing their Construction Tender *Vise* as a scanning target.
- Data was collected with the Laser Line Scanning and the ISS laser scaling camera payload (ONR Award # N00014-03-1-0750).

ONGOING TASKS

- Bluefin AUV will not be delivered until May of 2005 so work on the AUV mission control path planning routines, surface following controller and asynchronous data fusion software has not been completed.

RELATED PROJECTS

This project is for the development of Advanced Port Security Systems. Related projects would include ONR# N00014-03-1-0708, Development of a Mobile Inspection Platform, ONR# N00014-03-1-0750, Testing and Evaluation of the Mobile Inspection Platform, ONR# N00014-02-1-0719 and ONR# N00014-02-1-0825, Autonomous Underwater Vehicle for Homeland Defense.