



Naval Fuels & Lubricants

Cross Functional Team

Test Report

Impact of 50% Alcohol to Jet Blends on Aviation Turbine Fuel Filtration and Coalescence

NF&LCFT REPORT 441/14-015

20 June 2014

Prepared By:

TERRENCE DICKERSON
Chemical Engineer
AIR-4.4.5.1

NAVAIR Public Release 2014-1041
Distribution Statement A - Approved for public release; distribution is unlimited

Report prepared and released by:



**Naval Air Systems Command
Naval Fuels & Lubricants CFT
22229 Elmer Road
Patuxent River MD 20670-1534**

Reviewed and Approved by:

RICHARD A. KAMIN Fuels Team Lead AIR- 4.4.5
--

JOHN BUFFIN Aviation ISE Team Lead AIR- 4.4.5.1
--

Released by:

DOUGLAS F. MEARNES Fuels & Lubricants Systems Engineer AIR-4.4.1

TABLE OF CONTENTS

LIST OF TABLES	iv
LIST OF FIGURES	iv
EXECUTIVE SUMMARY	v
LIST OF ACRONYMS/ABBREVIATIONS	vi
DEFINITIONS.....	vi
1.0 BACKGROUND	1
2.0 OBJECTIVE	1
3.0 APPROACH	2
4.0 DISCUSSION	4
5.0 CONCLUSIONS.....	6
6.0 RECOMMENDATIONS.....	6
7.0 REFERENCES	6
APPENDIX A. TEST FUEL CHEMICAL AND PHYSICAL PROPERTIES.....	A-1
APPENDIX B. METHOD FOR INJECTING FUEL ADDITIVES TO THE TEST FLUID	B-1
APPENDIX C. TEST RIG SCHEMATIC.....	C-1
APPENDIX D. TEST RESULTS	D-1

LIST OF TABLES

Table	Title	Page
Table 1.	Test Overview.....	3
Table D-1.	Test Results.....	D-1

LIST OF FIGURES

Figure	Title	Page
Figure 1:	Effluent Free Water Concentration	5
Figure 2:	Effluent Particulate Contamination.....	5
Figure 3:	Test Housing Differential Pressure	6
Figure 4.	Test Rig Schematic.....	C-1

EXECUTIVE SUMMARY

In October 2009, Secretary of the Navy Ray Mabus directed the Navy to decrease its reliance on fossil fuels. The Secretary set a goal of operating with at least 50% of energy consumption coming from alternative sources by 2020. He also set forth the goal of demonstrating a Great Green Fleet, operating on 50% alternative fuel, by 2012 and deploying by 2016. The use of alternative/petroleum sourced aviation fuel blends is a critical component to achieving these goals. The alternative sourced fuels will come from non-food sources and must be compatible with all existing hardware without compromising performance, handling or safety. The increased use of alternative sources to produce naval tactical fuels will increase the Navy's energy independence while improving national security, decreasing environmental impact and strengthening the national economy. The objective of this test program is to ensure that all proposed alternative fuels perform equally or better than existing petroleum sourced fuels.

Alcohol to Jet (ATJ) fuels is an alternative sourced aviation fuel that is currently being evaluated. ATJ fuels are synthetic paraffin fuels produced from alcohols (isobutanol or n-butanol). Sugars, corn, grass/wood/biomass, and power plant/industrial CO₂ are all potential ATJ feedstocks. ATJ fuels are comprised of a mixture of C8, C12, C16, and C20 paraffins. The degree of branching is dependent on the alcohol starting material used.

ATJ had no negative impacts on filter separator performance and did not disarm coalescer or separator media when blended with JP-5 at a 1:1 by volume ratio as evident by satisfactory compliance with sediment removal, water removal, and differential pressure performance criteria defined in section 3.6 of MIL-PRF-32148 and sections 3.1.1(a & b), 3.1.3.1, and 3.1.4.1 of EI 1581 5th Edition. It is recommended that 50/50 ATJ fuel blends be approved for use with EI 1581 5th edition Category M and MIL-PRF-32148 qualified filter separators.

LIST OF ACRONYMS/ABBREVIATIONS

ATJ.....	Alcohol to Jet
GPM.....	gallons per minute
NAS.....	Naval Air Station
NATOPS	Naval Air Training and Operating Procedures Standardization
PPM.....	parts per million by volume
PSEF	Propulsion Systems Evaluation Facility
USAF	United States Air Force

DEFINITIONS

Biomass	plant material, vegetation, or agricultural waste used as the feedstock in the production of fuel
Coalescence	the ability to shed water
Effluent	stream leaving a system
Turnover	time required to flow the entire volume of fluid in a container, also known as residence time (volume of fuel ÷ volumetric flow rate)

Impact of 50% Alcohol to Jet Blends on Aviation Turbine Fuel Filtration and Coalescence

1.0 BACKGROUND

In October 2009, Secretary of the Navy Ray Mabus directed the Navy to decrease its reliance on fossil fuels. The Secretary set a goal of operating with at least 50% of energy consumption coming from alternative sources by 2020. He also set forth the goal of demonstrating a Great Green Fleet, operating on 50% alternative fuel, by 2012 and deploying by 2016. The use of alternative/petroleum sourced aviation fuel blends is a critical component to achieving these goals. The alternative sourced fuels will come from non-food sources and must be compatible with all existing hardware without compromising performance, handling or safety. The increased use of alternative sources to produce Naval tactical fuels will increase the Navy's energy independence while improving national security, decreasing environmental impact and strengthening the national economy. The objective of this test program is to ensure that all proposed alternative fuels perform equally or better than existing petroleum sourced fuels.

Alcohol to Jet (ATJ) fuels is an alternative sourced aviation fuel that is currently being evaluated. ATJ fuels are synthetic paraffin fuels produced from alcohols (isobutanol or n-butanol). Sugars, corn, grass/wood/biomass, and power plant/industrial CO₂ are all potential ATJ feedstocks. ATJ fuels are comprised of a mixture of C8, C12, C16, and C20 paraffins. The degree of branching is dependent on the alcohol starting material used.

The US Navy is in the process of evaluating 50% (by vol) ATJ fuel blends to determine their impacts on engine performance, handling and safety. In order for a 50/50 ATJ blend to be considered a drop-in replacement for petroleum derived aviation fuel, the blend must be compatible with all current fuel system components including filter separator systems.

Filter separators are commonly used onboard naval vessels and at shore stations to reduce solid and free water contamination to acceptable levels. As specified in MIL-DTL-5624V (JP-5) and MIL-DTL-83133H (JP-8), the maximum allowable level of solid contamination is 1.0 mg/L. MIL-STD-3004C¹ allows a maximum free water concentration of 10 ppm in JP-8. Naval Air Training and Operating Procedures Standardization (NATOPS) Aircraft Refueling Manual NAVAIR 00-80T-109 allows a maximum free water concentration of 10 ppm in JP-5.

2.0 OBJECTIVE

The objective of this test, in accordance with Navy SWP44FL-006: Naval Fuels & Lubricants CFT Aviation Qualification Protocol for Alternative Fuel/Fuel Sources², was to determine the effects of ATJ on filter separator performance when present in aviation turbine fuels at a concentration of 50% by volume.

3.0 APPROACH

3.1 Test Fuel

The effects of ATJ on filter separator performance were determined by testing a 50/50 JP5/ATJ fuel blend. The ATJ of the 50/50 JP-5/ATJ fuel blend was manufactured by Gevo[®] and procured by the United States Air Force (USAF). The ATJ was transferred from Wright-Patterson Air Force Base to the Propulsion Systems Evaluation Facility (PSEF) located at Naval Air Station (NAS) Patuxent River, MD in April 2014. ATJ was then blended with JP-5 at 1:1 by volume to produce a 50/50 blend. The test fuel met all MIL-DTL-5624V physical and chemical properties except for density at 15°C and flash point (see Appendix A). Both of these properties fell below the JP-5 limits due to the lower density and flash point of ATJ (the test fuel's density at 15°C and flash point were within the requirements of JP-8 as defined in MIL-DTL-83133H). However, these properties do not impact the validity of this test as any improvement in separation due to the lower density fuel is negligible (less than 1% difference between the density of the test fuel and the minimum spec requirement).

Prior to testing the 50/50 blend test fuel was water washed, recirculated through a filter separator, and then clay treated to remove additives (microseparator rating >95), sediment (<0.26 mg/L), and free water (<5 ppm). Directly prior to testing, the following additives were added in accordance with (IAW) Appendix B:

- A. Static Dissipater Additive, Stadis 450[®] (Octel America, Newark DE) at a concentration of 2.0 ± 0.2 mg/L.
- B. Fuel System Icing Inhibitor in accordance with MIL-DTL-85470 at a concentration of 0.15 percent (by volume) ± 0.01 percent.
- C. Corrosion Inhibitor, DCI-4A in accordance with MIL-DTL-25017 at a concentration of 15 ± 1 mg/L.

3.2 Test Overview

Testing was conducted IAW section 4.6.3 of MIL-PRF-32148³ (identical to EI1581 5th edition Section 4.3 for category M fuels and Type S filter separators⁴). These test conditions are summarized in Table 1.

Table 1. Test Overview

Test Condition	MIL-PRF-32148	EI 1581 5 th Ed.	Duration, minutes	Sampling Interval	Contaminant Level
Element Conditioning	4.6.3.1	4.3.2.4.2	30	N/A	No Contaminant Added
Water Injection	4.6.3.2	4.3.2.5.1	30	At 0, 5, 10 ^{s/s} , 20 ^{s/s} , and 30 ^{s/s} minutes	100 ppm
Solids Injection	4.6.3.3	4.3.2.6.1	75	Every 15 minutes before and after stop/start	72 mg/gal
Water Injection	4.6.3.4	4.3.2.7.1	150	At 0, 2, 5, 15, 30 ^{s/s} , 45, 60 ^{s/s} , 75, 90 ^{s/s} , 105, 120 ^{s/s} , 135, and 150 ^{s/s} min	100 ppm
Water Injection	4.6.3.5	4.3.2.7.2	30	At 2, 5, 10 ^{s/s} , 20 ^{s/s} , and 30 minutes	30,000 ppm
Filter Inspection	-	4.3.2.8	Post-Test	-	-

^{s/s} Measurements made after a stop/start. A stop/start procedure is achieved by shutting and then immediately opening a downstream valve from the test housing within 4 seconds.

A schematic of the test rig can be found in Appendix C. For this test, a Velcon Filters Inc. test housing (part number VV1033150NVY) was used. Two 20 inch long by 3.75 inch O.D Velcon I-420MMF coalescer elements conforming to MIL-PRF-32148 (listed on MIL-QPL-32148⁵) and one 24 inch long by 4.25 inch O.D. Facet SS-424Z-COM separator were used. The total flow rate through the test housing was 100% of the rated flow rate of the elements, 35 gallons per minute (17.5 gallons per coalescer).

The addition of 100 ppm and 30,000 ppm water was achieved by injecting 13.2 mL/min and 1.0 gpm of water, respectively. To ensure sufficient mixing, the water was injected upstream of a centrifugal supply pump having a rotational speed of 2,500 RPM. The concentration of free water in the effluent stream was determined using ASTM method D3240. The test instrument used for the measurement was a D-2 Hydro-Light JF-WA1 water pad tester.

The solids injection rate of 72 mg/gal was attained by injecting the test fuel with a concentrated fuel and dirt slurry (10.0 g dirt/gal). A 10% by weight Copperas Red Iron Oxide R-9998 and 90% by weight Arizona A1 Ultrafine Test Dust ISO 12103-1 mixture was used as the solid contaminant. The concentrated slurry was injected at a rate of 0.25 gpm upstream of the filter/separator housing. The solid concentration of the filter/separator effluent fuel stream was measured per ASTM D2276 during the solids holding phase.

Due to limited tank availability, a single pass of the test fuel through the test housing was not possible. The risks associated with recirculating the fuel such as introduction of additional contamination and degradation of the fuel were mitigated by filtering the fuel through an additional filter/separator housing prior to the fuel returning to the supply tank in addition to using 7,500 gallons of test fuel. The total volume of fuel used during this test represents only 1.5 turnovers of the 7,500 gallons in the supply tank.

3.3 Acceptance Criteria

As defined in section 3.6 of MIL-PRF-32148:

In order to successfully pass the single-element test, the differential pressure across the element in combination with the separator stage shall not exceed 6 pounds per square inch (psi) at 100 percent rated flow when using a fuel containing less than 0.26 mg/L solids and 5 ppm free water. During the solids injection phase, the differential pressure across the element at rated flow shall not be greater than 15 psi before 50 minutes and 45 psi before 75 minutes.

The average weight of solids in the effluent fuel samples shall be not greater than 0.26 mg/L and the weight of solids in any single sample shall be not greater than 0.5 mg/L when measured in accordance with ASTM D2276. The effluent fuel samples shall contain not more than 10 parts per million by volume (ppm) of undissolved water when measured in accordance with ASTM D3240.

Acceptable performance criteria defined in section 3.6 of MIL-PRF-32148 are identical to requirements stated in sections 3.1.1(a & b), 3.1.3.1, and 3.1.4.1 of EI 1581 5th Edition with the exception that MIL-PRF-32148 requires effluent undissolved water concentrations not more than 10 ppm. EI 1581 5th edition requires undissolved water concentrations not more than 15 ppm in the effluent.

4.0 DISCUSSION

At no point during the test did the concentration of free water in the effluent exceed 10 ppm as can be seen in Figure 1. Influent free water concentrations were also measured at the beginning of each 0.01% water injection phase to ensure the presence of free water. Influent free water concentrations of 82.3 ppm and 102.4 ppm were measured during the first and second 0.01% water injection phases, respectively.

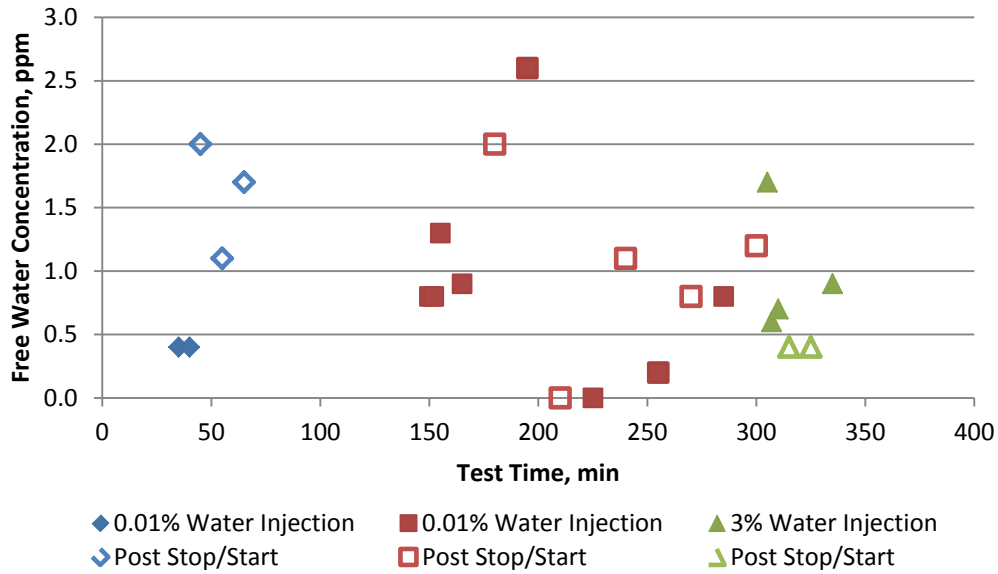

Figure 1: Effluent Free Water Concentration

The results from the solid holding phase of testing can be found in Figure 2. The average concentration of solids measured in the effluent fuel stream during the solids holding phase was 0.03 mg/L (0.05 mg/L prior to stop/starts, 0.01 mg/L after stop/starts). No sample contained more than 0.50 mg/L of sediment. The largest amount of sediment measured in an effluent sample was 0.18 mg/L.

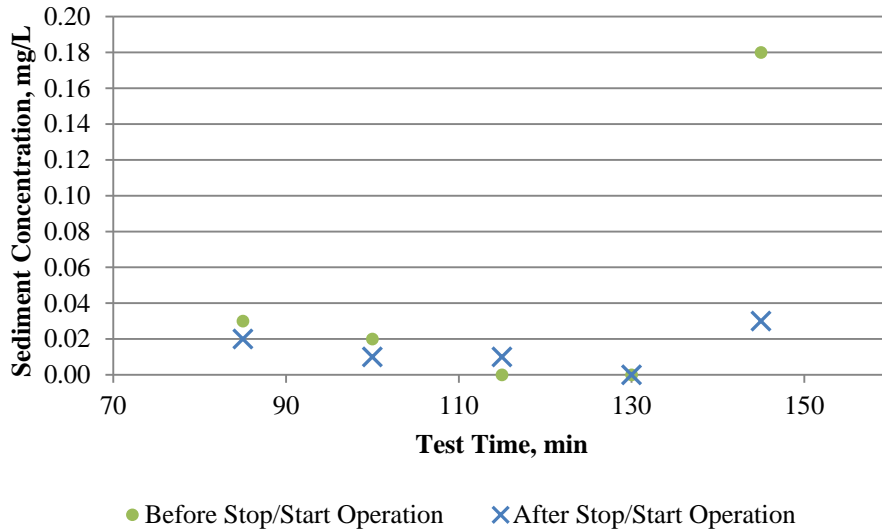

Figure 2: Effluent Particulate Contamination

Additionally, the differential pressure across the filter/separator housing satisfactorily met all of the differential pressure requirements stated in Section 3.3 (Figure 3). All test data can be found in Appendix D.

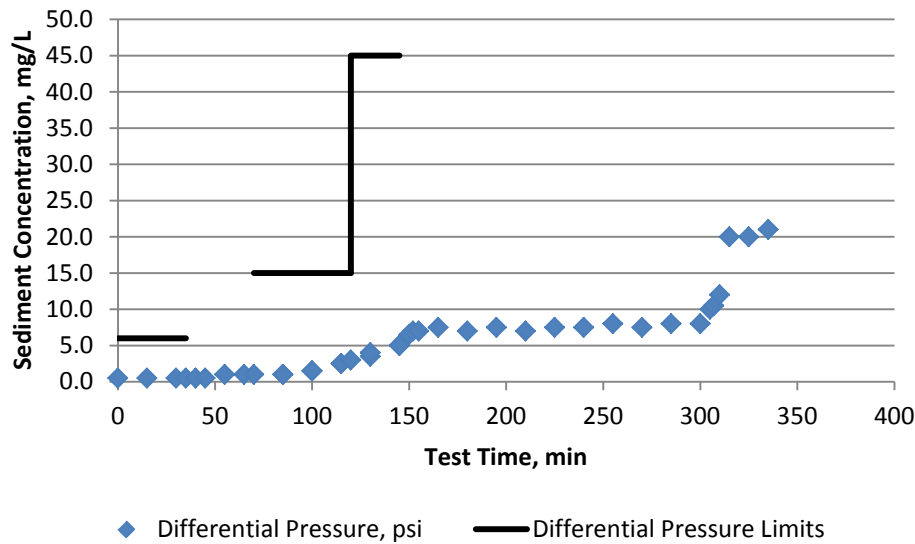

Figure 3: Test Housing Differential Pressure

5.0 CONCLUSIONS

ATJ had no negative impacts on filter separator performance and did not disarm coalescer or separator media when blended with JP-5 at a 1:1 ratio. 50/50 fuel blends met all sediment removal, water removal, and differential pressure performance criteria defined in section 3.6 of MIL-PRF-32148 and stated in section 3.3 of this test report.

6.0 RECOMMENDATIONS

It is recommended that 50/50 JP-5/8/ATJ fuel blends be approved for use with EI 1581 5th edition Category M and MIL-PRF-32148 qualified filter separators.

7.0 REFERENCES

1. U.S. Department of Defense, August 2011. *MIL-STD-3004C Quality Assurance/Surveillance for Fuels, Lubricants and Related*
2. United States Navy-Naval Fuels & Lubricants CFT. *SWP44FL-006 Naval Fuels & Lubricants CFT: Aviation Qualification Protocol for Alternative Fuel/Fuel Sources*
3. U.S. Department of Defense, July 2005. *MIL-PRF-32148 Performance Specification Filter Separator Elements, Fluid, Pressure, Aviation and Distillate Fuel, Naval Shipboard*
4. Energy Institute, July 2002. *EI 1581 5th Edition Specifications and Qualification Procedures For Aviation Jet Fuel Filter/Separators*
5. U.S. Department of Defense, April 2010. *MIL-QPL-32148: Filter Separator Elements, Fluid, Pressure, Aviation and Distillate Fuel, Naval Shipboard*

APPENDIX A. TEST FUEL CHEMICAL AND PHYSICAL PROPERTIES

Test (Units)	Method	JP-5, MIL-DTL-5624V Requirements		50/50 JP-5/ATJ
		Minimum	Maximum	
Color, Saybolt	D6045	Report		14
Total Acid Number (mgKOH/g)	D3242		0.015	0.003
Aromatics (volume %)	D1319	8.0 ^a	25.0	9.3
Sulfur, Mercaptan (mass %) or, Doctor Test	D3227		0.002	0.001
	D4952		Negative	-
Sulfur, Total				
XRF (mass %), or	D4294		0.20	0.07
UV Fluorescence (mg/kg)	D5453		2000	-
Distillation	D86			
Initial (°C)			Report	172
10% Recovered (°C)			205	183
20% Recovered (°C)			Report	187
50% Recovered (°C)			Report	196
90 % Recovered (°C)			Report	235
End Point (°C)			300	263
Residue (volume %)			1.5	1.5
Loss (volume %)			1.5	0.1
Flash Point (°C)	D93	60.0		57.0^b
Density at 15 °C (kg/L)	D4052	0.788	0.845	0.784^b
Freezing Point (°C)	D5972		-46	-58
Viscosity at -20 °C (mm ² /s)	D445		8.5	5.0
Net Heat of Combustion (MJ/kg)	D4809	42.6		43.4
Ignition Quality, Derived Cetane Number	D6890		Report	35.7
Hydrogen Content (mass %)	D7171	13.4		14.5
Smoke Point (mm)	D1322	19.0		27.9
Copper Strip Corrosion, two hours at 100 °C	D130		1	1a
Thermal stability				
Pressure Drop (mm Hg)	D3241		25	0
Heater Tube Deposit			<3	1
Existent Gum (mg/100 mL)	D381		7.0	5.0
Particulate Matter (mg/L)	D5452		1.0	0.2
Filtration Time (minutes)	MIL-DTL-5624V		15	6
Micro Separometer Rating	D3948	^c		63 ^d
Fuel System Icing Inhibitor (volume %)	D5006	0.10	0.15	0.13 ^d

^a Requirement only applies to fuels containing synthetic blending components.

^b These properties meet the JP-8 MIL-DTL83133H specification limits but not the JP-5 MIL-DTL-5624V specification limits.

^c Value is dependent on additives in the fuel. No minimum requirement for fuels containing SDA, as SDA is not approved for use in JP-5

^dMSEP and FSII values of test fuel measured after adding additives and prior to testing (sect 3.1).

This Page Intentionally Left Blank

APPENDIX B. METHOD FOR INJECTING FUEL ADDITIVES TO THE TEST FLUID

B.1 SCOPE

B.1.1 Scope. This appendix details the method to be used for injecting the test fluid with the required additives.

B.2 PROCEDURE

B.2.1 Test fuel cleanup. The test fluid shall be filtered until an AquaGlo reading of 5 parts per million or less is obtained when tested in accordance with ASTM-D3240. The test fluid shall then be clay filtered until a Micro-Separometer (MSEP) Surfactants value of 95 or greater is obtained when tested in accordance with ASTM-D3948. All filtration equipment shall be bypassed before adding the additives.

B.2.2 Additive injection. The test fuel shall be inhibited according to the amounts specified in 3.1. To determine the duration of recirculation needed to achieve a homogenous mixture of fuel and inhibitors, the following procedure shall be used. Inject additive A upstream of the main pump. The conductivity shall be measured at 5-minute intervals after the additive is introduced to the fuel. The elapsed time from the initial addition of the additive to the time when three successive conductivity measurements at 5-minute intervals are within ± 20 pico Siemens/meter (pS/m) shall be noted as the mixing time. Additives B shall then be added in the same manner allowing the same mixing time. Next additive C shall be added allowing the same mixing time before beginning the test.

B.3 CAUTION

B.3.1 Handling of additives. Refer to manufacturer's safety data sheets for precautions to be taken while handling fuel inhibitors.

This Page Intentionally Left Blank

APPENDIX C. TEST RIG SCHEMATIC

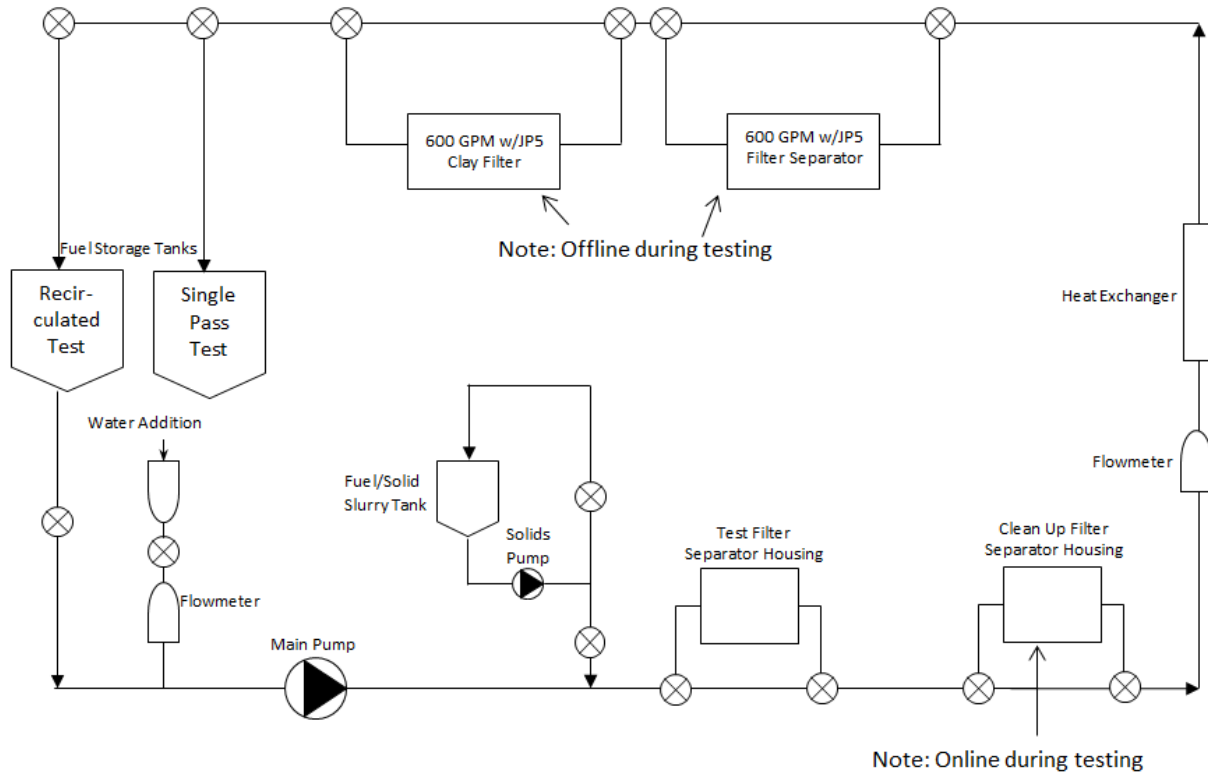

Figure 4. Test Rig Schematic

This Page Intentionally Left Blank

APPENDIX D. TEST RESULTS

Table D-1. Test Results

Phase	Cum. Time, min	Fuel Flow Rate, gpm	ΔP , psi	k, pS/m	Free Water Conc, ppm	Solids Conc, mg/L	Temp, °F
Baseline	0	34.46	0.5	528	0.3 (inlet)	0.09 (inlet)	88.5
	15	34.46	0.5				88.5
	30	34.46	0.5	633			88.7
Water Coalescence, 100 ppm	35	34.46	0.5	702	0.4		88.5
	40	34.46	0.5		0.4		88.2
	45 s/s	34.46	0.5		2.0		88.1
	55 s/s	34.46	1.0		1.1		88.0
	65 s/s	34.46	1.0	815	1.7		88.0
Solids Holding, 72 mg/gal	70	34.46	1.0	815			87.5
	85	34.46	1.0		0.8	0.03	87.4
	85 s/s	34.46	1.0			0.02	87.4
	100	34.46	1.5	806		0.02	87.4
	100 s/s	34.46	1.5			0.01	87.4
	115	34.46	2.5		0.7	0.00	87.2
	115 s/s	34.46	2.5			0.01	87.1
	120	34.46	3.0				87.4
	130	34.46	3.5	845		0.00	87.3
	130 s/s	34.46	4.0			0.00	87.4
	145	34.46	5.0		0.4	0.18	87.2
	145 s/s	34.46	5.0			0.03	87.2
Low Water Coalescence, 100 ppm	150	34.46	6.5	838	0.8		87.4
	152	34.46	7.0		0.8		87.3
	155	34.46	7.0		1.3		87.4
	165	34.46	7.5	835	0.9		87.1
	180 s/s	34.46	7.0		2.0		86.8
	195	34.46	7.5		2.6		86.5
	210 s/s	34.46	7.0	857	0.0		86.4
	225	34.46	7.5		0.0	0.21	85.8
	240 s/s	34.46	7.5		1.1		85.7
	255	34.46	8.0	840	0.2		87.6
	270 s/s	34.46	7.5		0.8		87.4
	285	34.46	8.0		0.8	0.07	87.5
	300 s/s	34.46	8.0		1.2		87.4

Appendix D. Test Results Cont'd

Phase	Cum. Time, min	Fuel Flow Rate, gpm	ΔP , psi	k, pS/m	Free Water Conc, ppm	Solids Conc, mg/L	Temp, °F
High Water Coalescence, 30,000 ppm	305	34.46	10.0	830	1.7		87.5
	307	34.46	10.5		0.6		87.4
	310	34.46	12.0		0.7		87.2
	315 s/s	34.46	20.0	830	0.4		86.7
	325 s/s	35.07	20.0		0.4		86.2
	335	34.46	21.0	856	0.9		86.2

s/s= indicates measurements taken after a stop/start flow interruption

REPORT DOCUMENTATION PAGE

Form Approved
OMB No. 0704-0188

Public reporting burden for this collection of information is estimated to average 1 hour per response, including the time for reviewing instructions, searching existing data sources, gathering and maintaining the data needed, and completing and reviewing this collection of information. Send comments regarding this burden estimate or any other aspect of this collection of information, including suggestions for reducing this burden to Department of Defense, Washington Headquarters Services, Directorate for Information Operations and Reports (0704-0188), 1215 Jefferson Davis Highway, Suite 1204, Arlington, VA 22202-4302. Respondents should be aware that notwithstanding any other provision of law, no person shall be subject to any penalty for failing to comply with a collection of information if it does not display a currently valid OMB control number. **PLEASE DO NOT RETURN YOUR FORM TO THE ABOVE ADDRESS.**

1. REPORT DATE (DD-MM-YYYY) 20-06-2014		2. REPORT TYPE Technical		3. DATES COVERED (From - To) 28-05-2014-01-01-2014	
Impact of 50% Alcohol to Jet Blends on Aviation Turbine Fuel Filtration and Coalescence				5a. CONTRACT NUMBER N/A	
				5b. GRANT NUMBER N/A	
				5c. PROGRAM ELEMENT NUMBER N/A	
6. AUTHOR(S) Dickerson, Terrence; Author Buffin, Jack.; Editor Kamin, Richard ; Editor Mearns, Douglas ; Editor				5d. PROJECT NUMBER N/A	
				5e. TASK NUMBER N/A	
				5f. WORK UNIT NUMBER N/A	
7. PERFORMING ORGANIZATION NAME(S) AND ADDRESS(ES) Naval Fuels & Lubricants Cross Functional Team 22229 Elmer Road Patuxent River, MD 20670				8. PERFORMING ORGANIZATION REPORT NUMBER NF&LCFT Report 441/14-015	
9. SPONSORING / MONITORING AGENCY NAME(S) AND ADDRESS(ES) Mobility Fuels Program Chief of Navy Operations N45 Rm 2E258 2000 Navy Pentagon Washington DC 20350-2000				10. SPONSOR/MONITOR'S ACRONYM(S) N/A	
				11. SPONSOR/MONITOR'S REPORT NUMBER(S) N/A	
12. DISTRIBUTION / AVAILABILITY STATEMENT A Approved for public release; distribution is unlimited.					
13. SUPPLEMENTARY NOTES N/A					
14. ABSTRACT <p>In October 2009, Secretary of the Navy Ray Mabus directed the Navy to decrease its reliance on fossil fuels. The Secretary set a goal of operating with at least 50% of energy consumption coming from alternative sources by 2020. He also set forth the goal of demonstrating a Great Green Fleet, operating on 50% alternative fuel, by 2012 and deploying by 2016. The use of alternative/petroleum sourced aviation fuel blends is a critical component to achieving these goals.</p> <p>Alcohol to Jet (ATJ) fuels is an alternative sourced aviation fuel that is currently being evaluated. ATJ fuels are synthetic paraffin fuels produced from alcohols (isobutanol or n-butanol). Sugars, corn, grass/wood/biomass, and power plant/industrial CO₂ are all potential ATJ feedstocks. ATJ fuels are comprised of a mixture of C8, C12, C16, and C20 paraffins. The degree of branching is dependent on the alcohol starting material used.</p> <p>ATJ had no negative impacts on filter separator performance and did not disarm coalescer or separator media when blended with JP-5 at a 1:1 by volume ratio as evident by satisfactory compliance with sediment removal, water removal, and differential pressure performance criteria defined in section 3.6 of MIL-PRF-32148 and sections 3.1.1(a & b), 3.1.3.1, and 3.1.4.1 of EI 1581 5th Edition. It is recommended that 50/50 ATJ fuel blends be approved for use with EI 1581 5th edition Category M and MIL-PRF-32148 qualified filter separators.</p>					
15. SUBJECT TERMS ATJ, JP-5, 50/50 JP-5/ATJ, Filter Separator, Qualification					
16. SECURITY CLASSIFICATION OF:			17. LIMITATION OF ABSTRACT Unclassified Unlimited	18. NUMBER OF PAGES 21	19a. NAME OF RESPONSIBLE PERSON Douglas F. Mearns
a. REPORT UNCLASSIFIED	b. ABSTRACT UNCLASSIFIED	c. THIS PAGE UNCLASSIFIED			19b. TELEPHONE NUMBER (include area code) 301-757-3421