



WALLACE H. COULTER SCHOOL OF ENGINEERING  
*Technology Serving Humanity*

## MEMORANDUM

Subject: Progress Report 015–  
Chaotic LIDAR for Naval Applications: FY14 Q3 Progress Report (4/1/2014– 6/30/2014)

This document provides a progress report on the project “Chaotic LIDAR for Naval Applications” covering the period of 4/1/2014–6/30/2014.

20150309456

## **FY14 Q3 Progress Report: Chaotic LIDAR for Naval Applications**

This document contains a **Progress Summary for FY14 Q3**.

### **Progress Summary for FY14 Q3**

The use of chaotic lidar for underwater system experiments progressed in this quarter. Experiments were set up for ranging using the chaotic system. Channel identification experiments continued, using a high speed receiver and adaptive signal processing.

The chaotic lidar project was presented at the Defense, Sensing, and Security conference in Baltimore, MD on 07 May, with a talk entitled "Chaotic Lidar for Underwater Channel Identification". The slides from this presentation are attached.

# Chaotic Lidar for Underwater Channel Identification

Luke Rumbaugh

Department of Electrical and Computer Engineering  
Clarkson University, Potsdam, NY

SPIE DSS 2014  
Ocean Sensing and Monitoring  
07 May 14

- Introduction
- Channel Identification
- Chaotic Lidar
- Preliminary Results
- Status and Future Work
- Conclusion

- Context
  - Intensity-modulated optical system operating in water (sensor, communications, ranging, imaging, mapping)
- Problem statement
  - Measure variation in system response as a function of frequency of intensity modulation
  - i.e., transfer function  $H(f)$  of the water

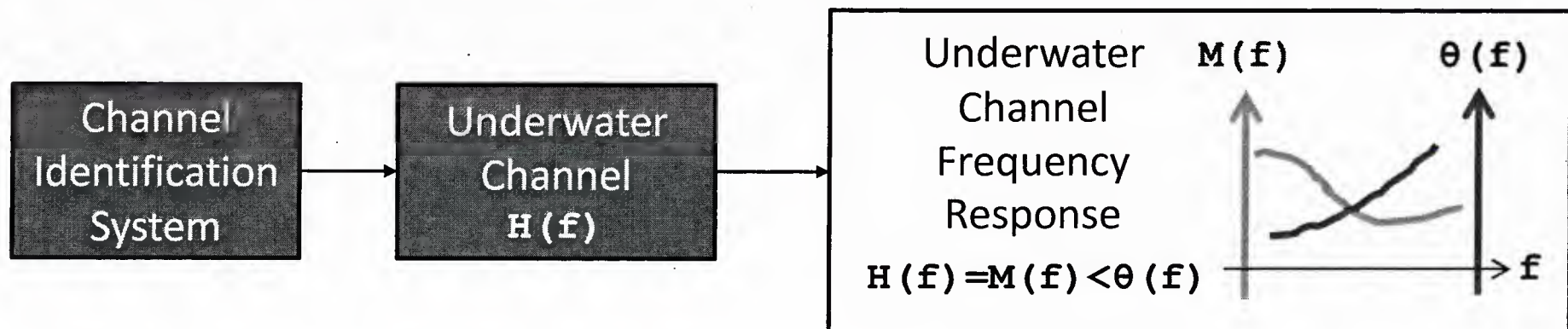

- Modulate optical carrier with radar signals
- Modulation discrimination against scattered light
  - Scattered light decorrelates as phase randomized
  - Decorrelation increases exponentially with frequency
  - Electrical discrimination improves performance
- Continuous monitoring of modulation response
  - Decorrelation effect changes with water conditions
  - Would like to explore frequency spectrum to 1 GHz

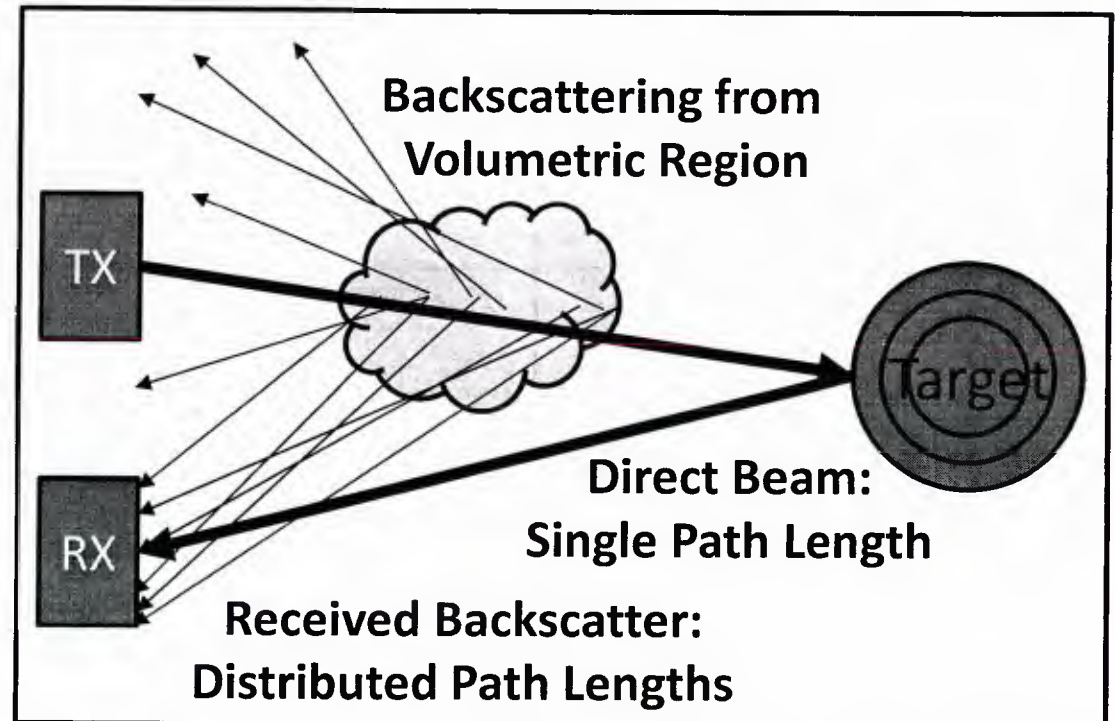
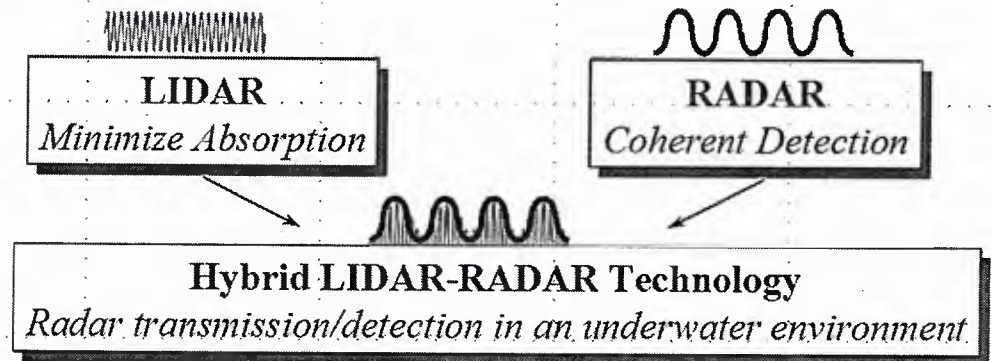

- Technology challenge for channel ID:  
GHz modulation with W power
- Systems to date
  - Bulk CW lasers with external modulators
  - Diodes with direct current modulation
  - Mode-locked pulsed lasers
  - Fiber lasers with high speed modulator
- Proposed: Internally modulated fiber laser
  - No modulator subsystem
  - Fiber laser allows high frequency
  - Fiber amplifiers allow high power
  - Frequency doubler for NIR → green

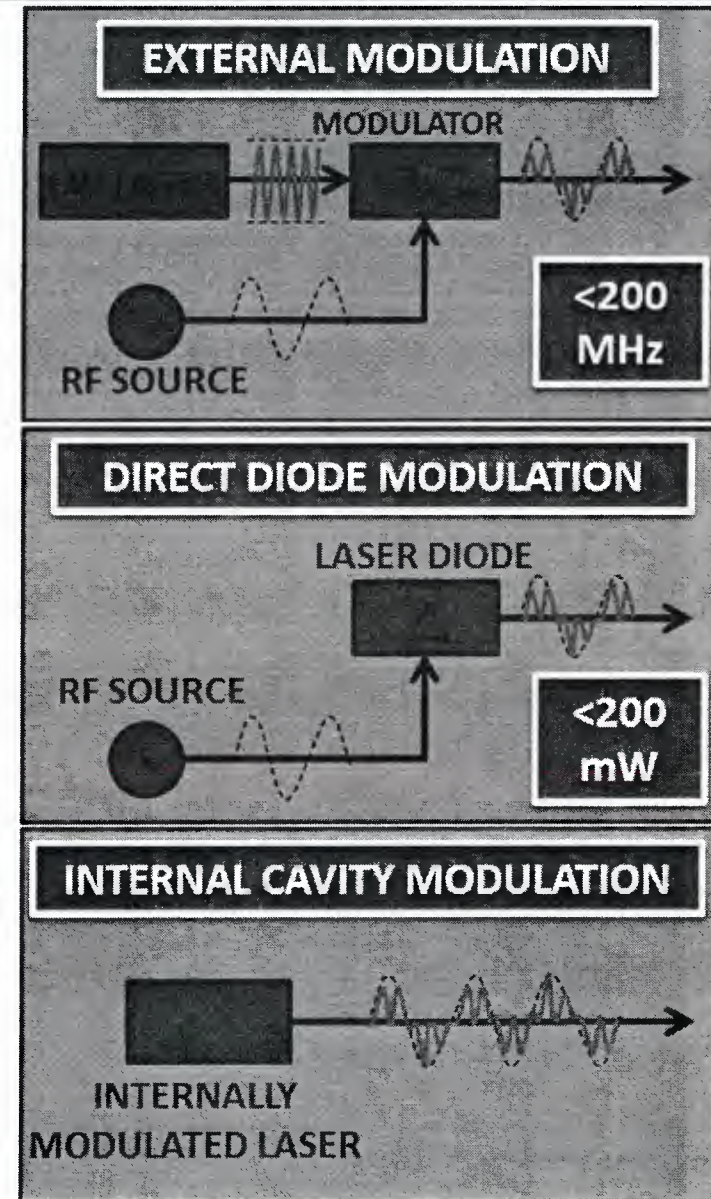

- Chaotic ytterbium-doped fiber laser
- Uses ultralong cavity (>100 m) to encourage simultaneous, incoherent lasing of many chaotically competing resonant modes

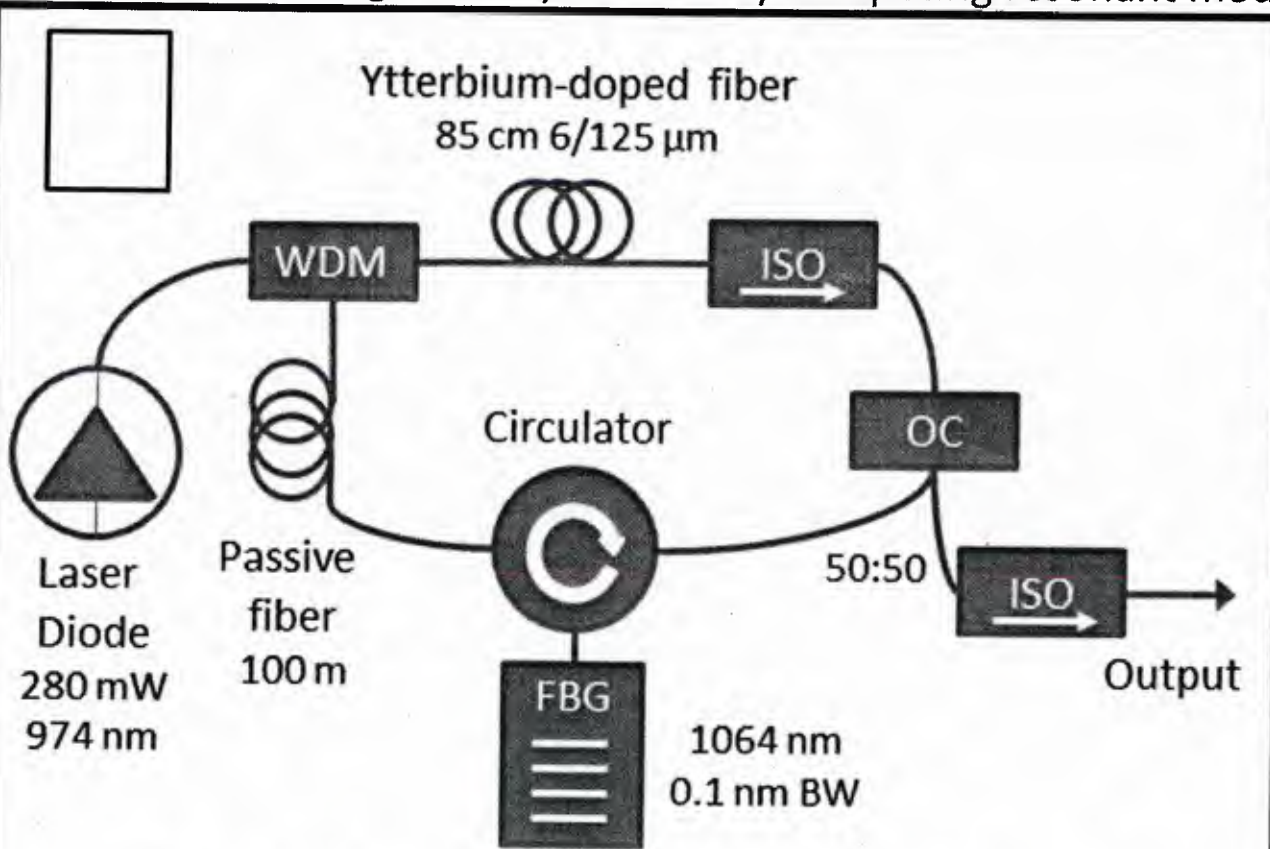
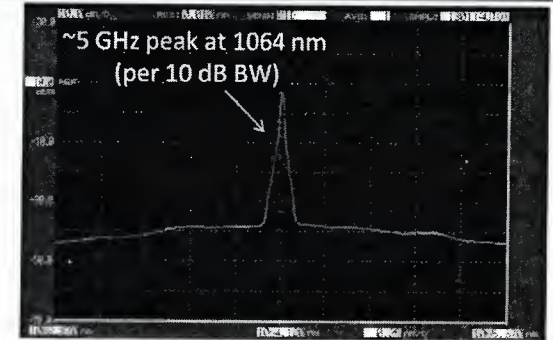

WDM: Wavelength-division multiplexer; ISO: Isolator;  
OC: Output coupler; FBG: Fiber Bragg grating

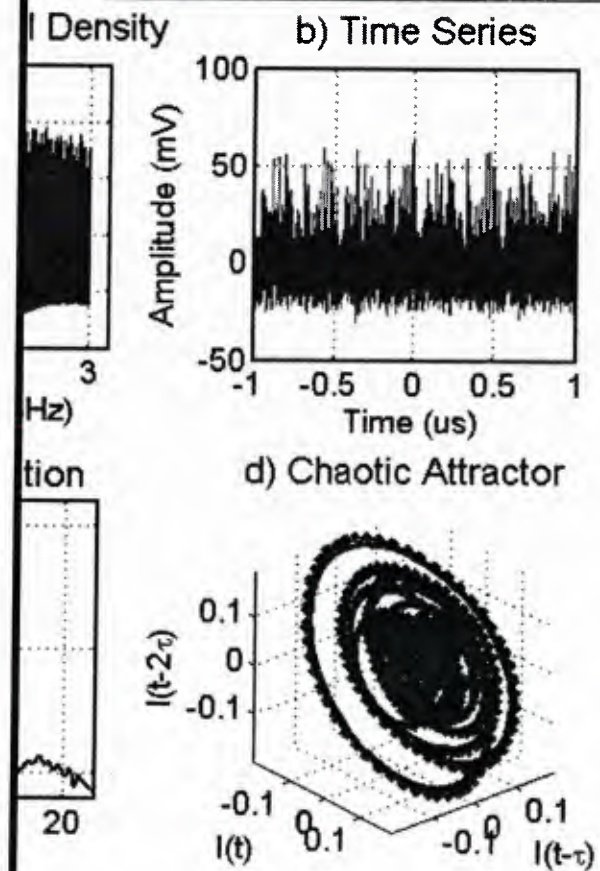

- Numerical modeling of fiber amplifiers using custom code to solve rate equations
- Both steady state and dynamic simulations

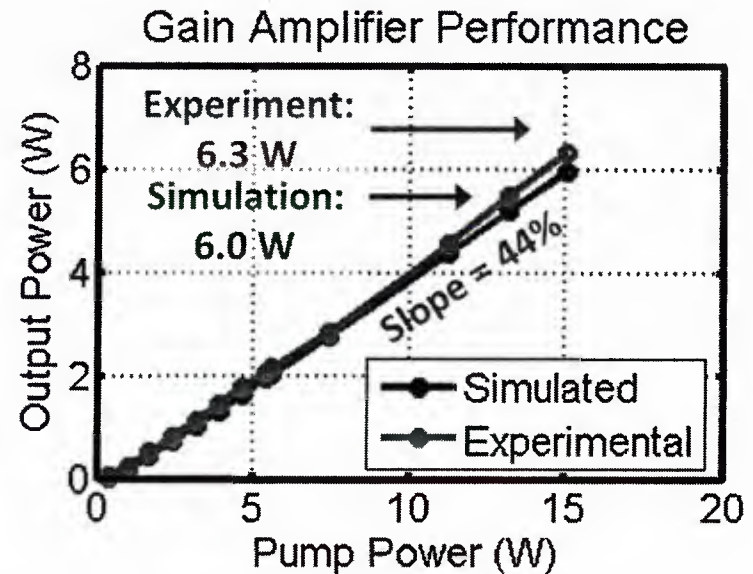
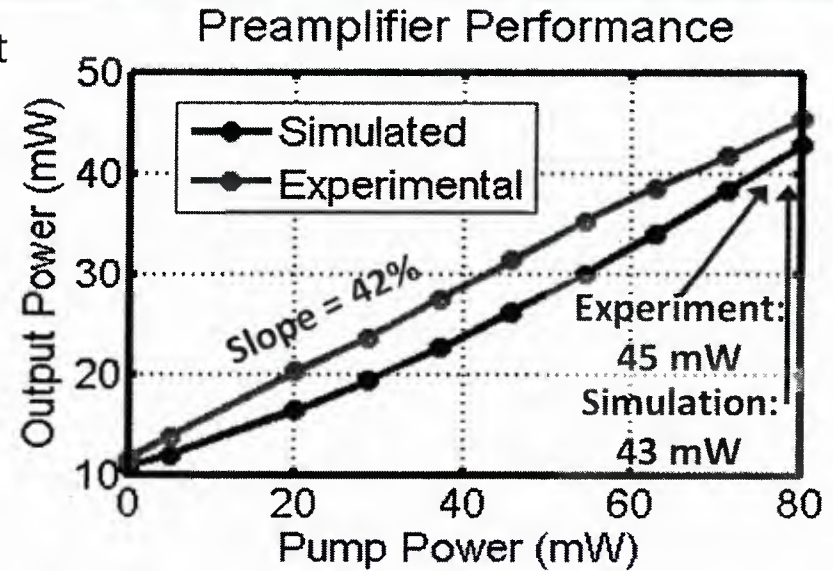
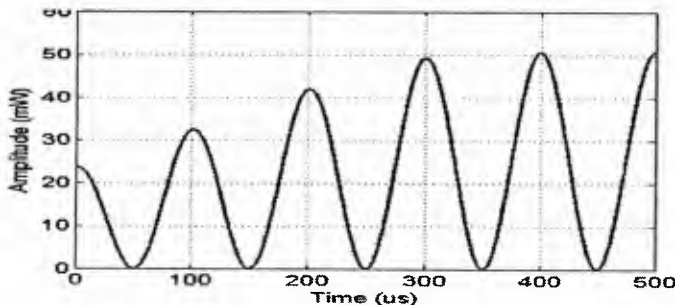
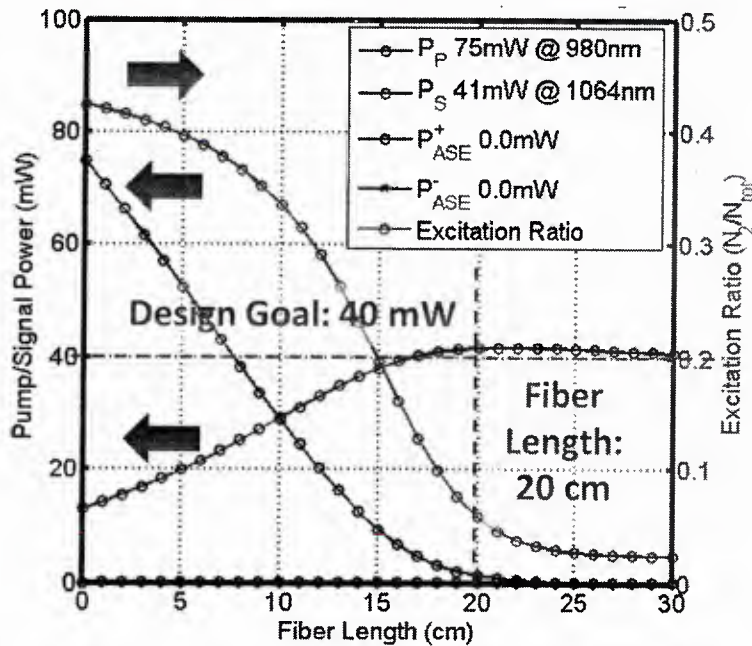

# Chaotic Lidar Transmitter

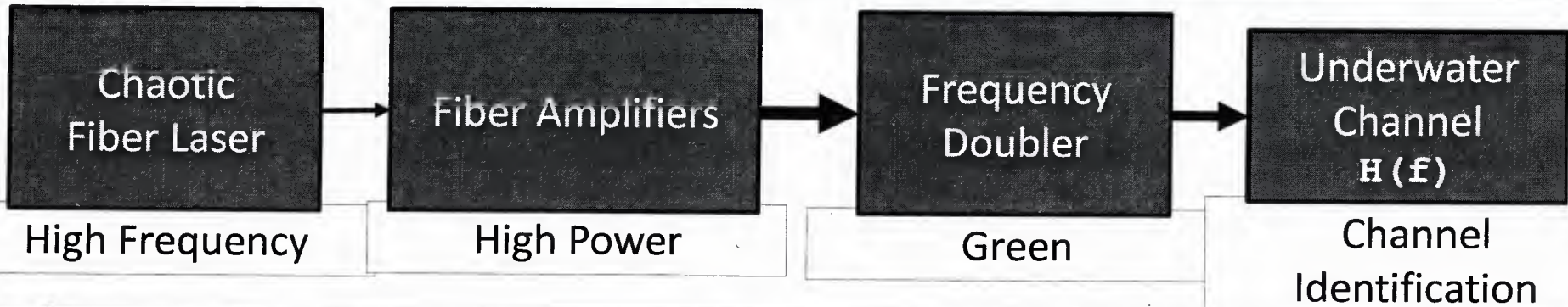

## Fiber Laser and Amplifier



Gain amplifier  
on board

Fiber  
output to  
free space

Fiber laser  
and pre-  
amplifier in  
enclosure

## Frequency Doubler



Focusing  
optics

Nonlinear  
crystal

Output  
optics

Receiver  
optics

## Correlation-based ranging:

- Wideband  $\rightarrow$  high resolution
- Processing gain  $\rightarrow$  sensitivity
- Unambiguous thumbtack peak

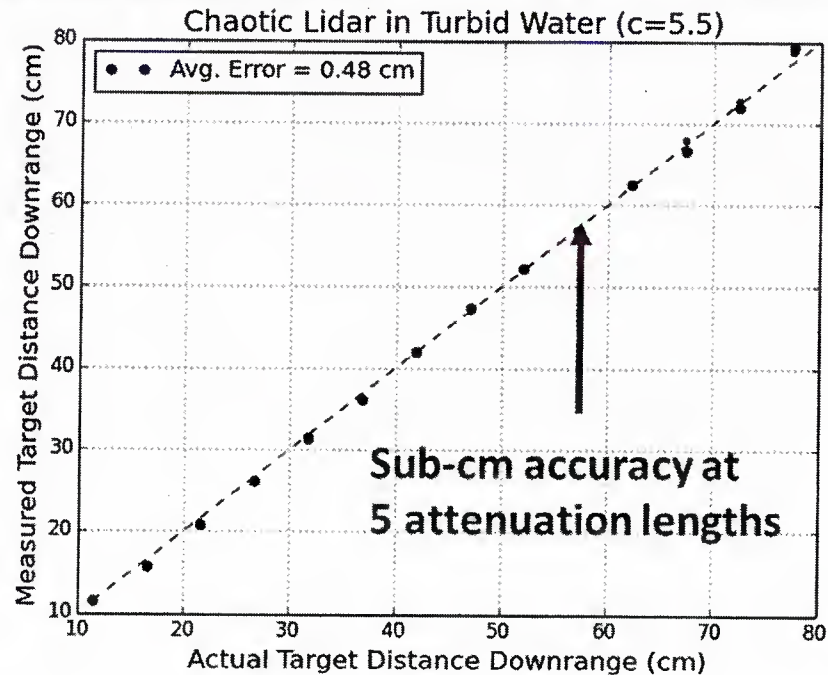
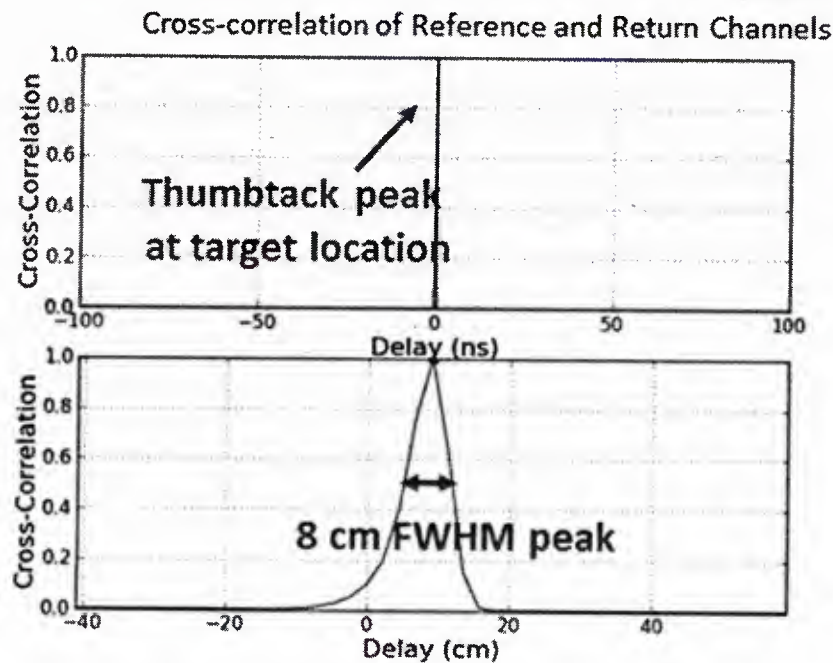
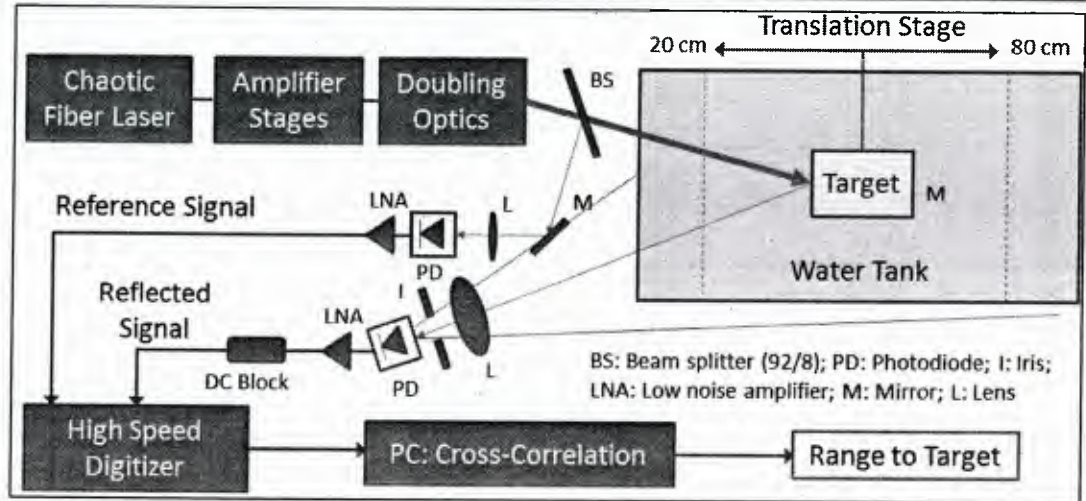

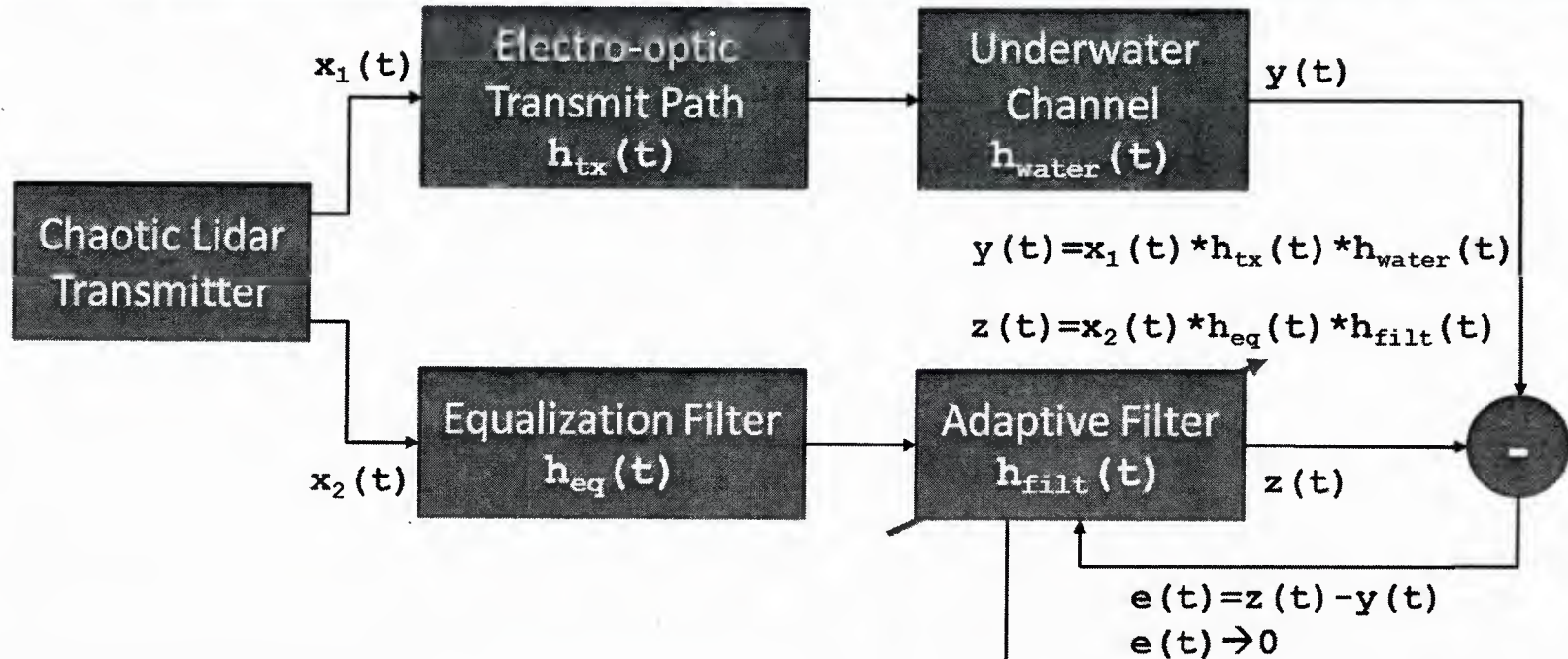

- Approach used in communications channel identification
- Leverages wideband chaotic signal as probe

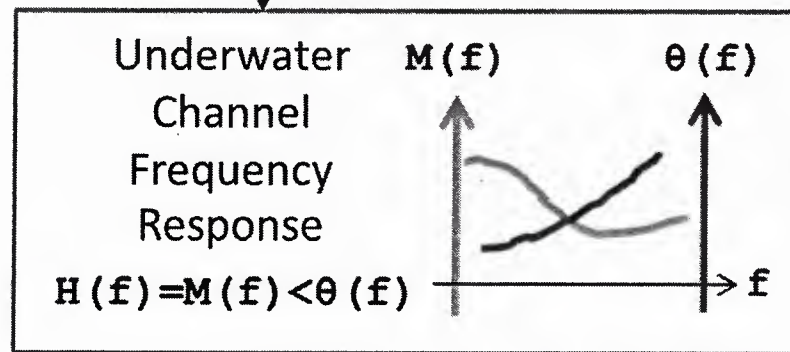

- Digitized chaotic signal used for channel identification on known digital filter

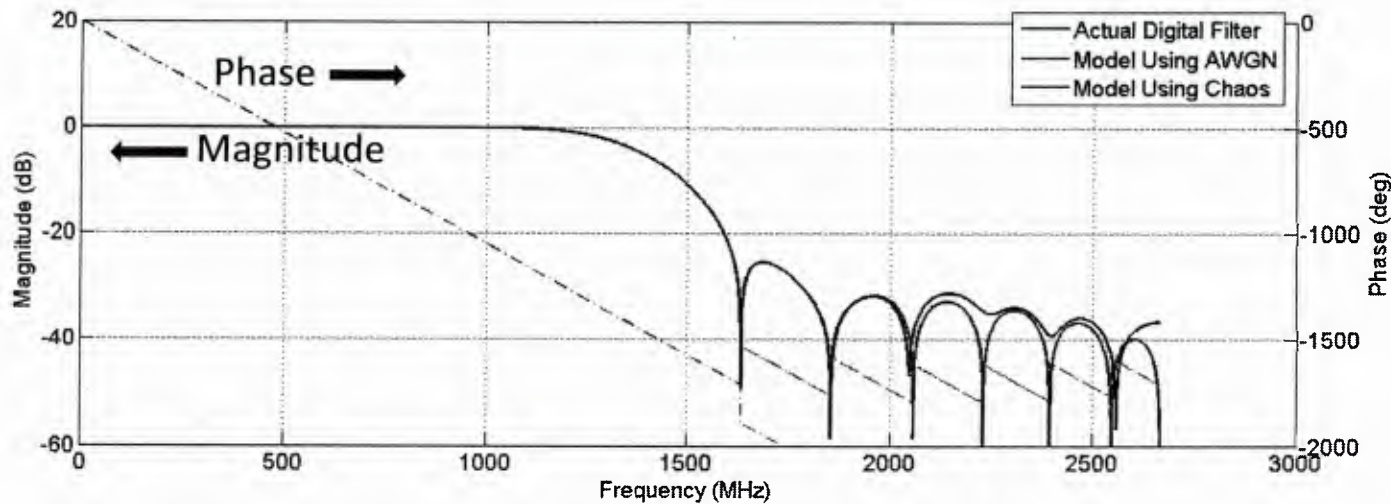

- Free space channel identification using known digital filter as DUT

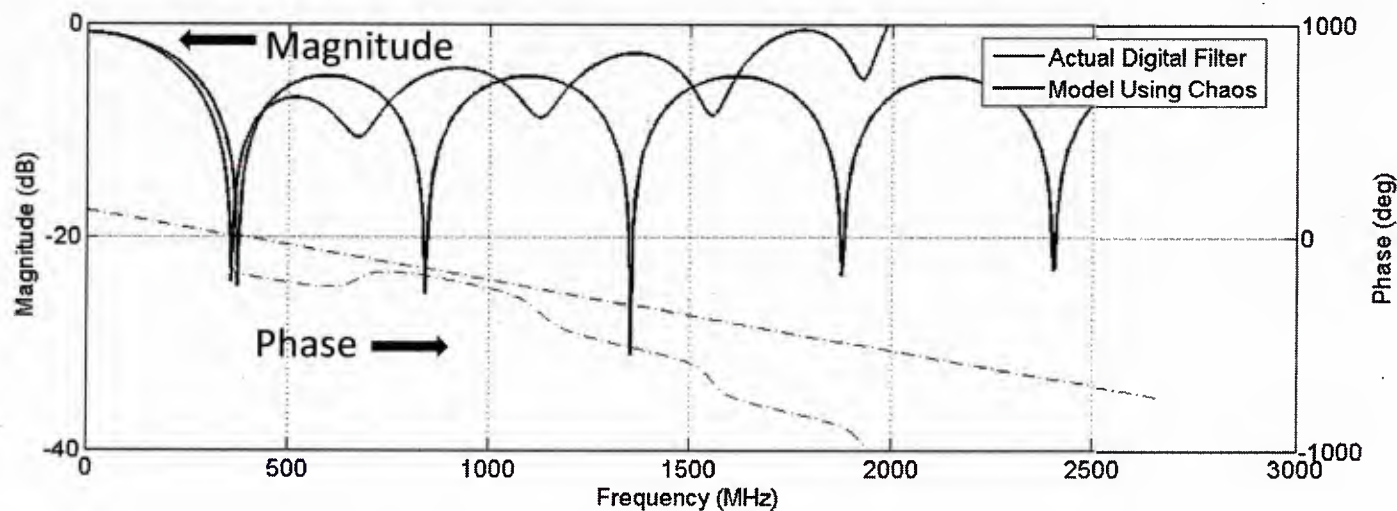

# Channel Identification Experimental Setup

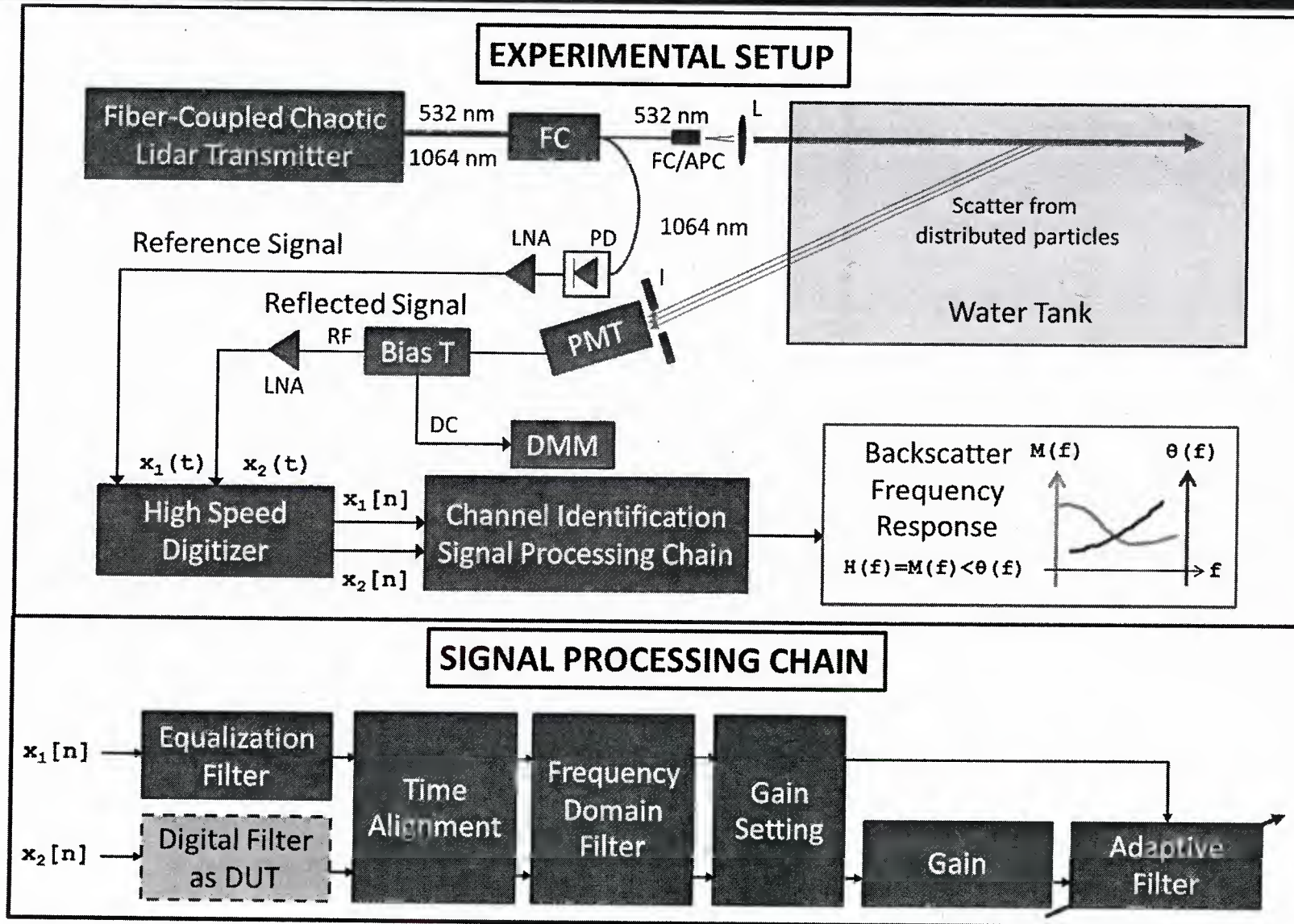

FC: Fiber coupler; L: Lens; PD: Photodiode; M: Mirror; LNA: Low-noise amplifier; PMT: Photomultiplier tube;  
RF: Radio frequency; DC: Direct current; DMM: Digital multimeter; DUT: Device under test

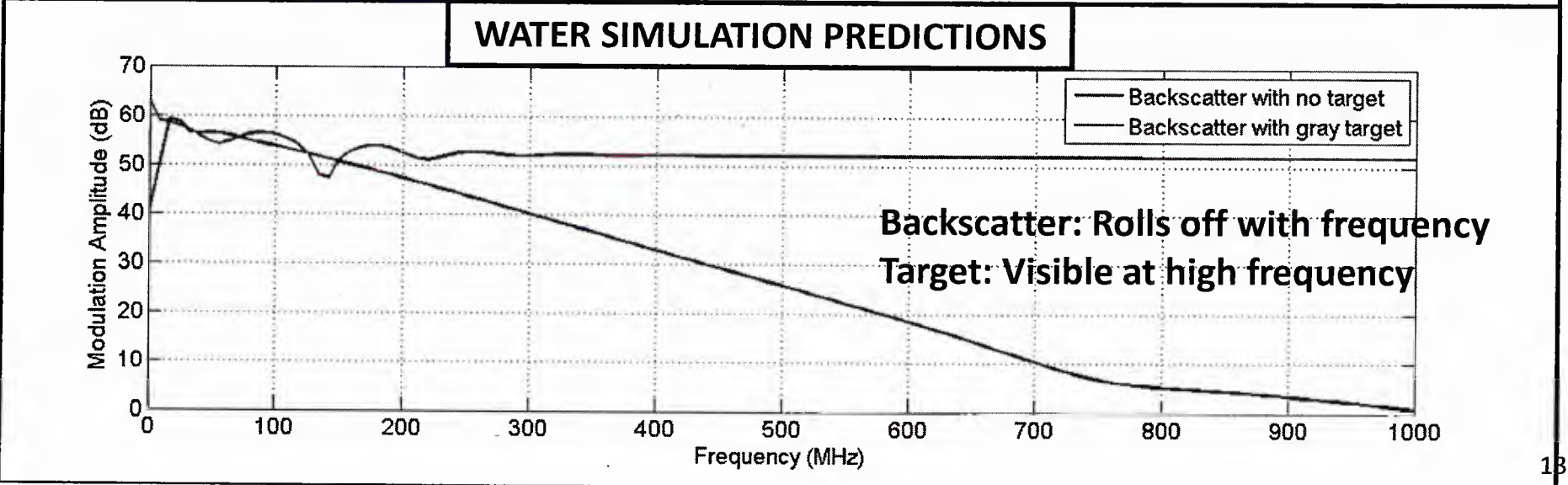
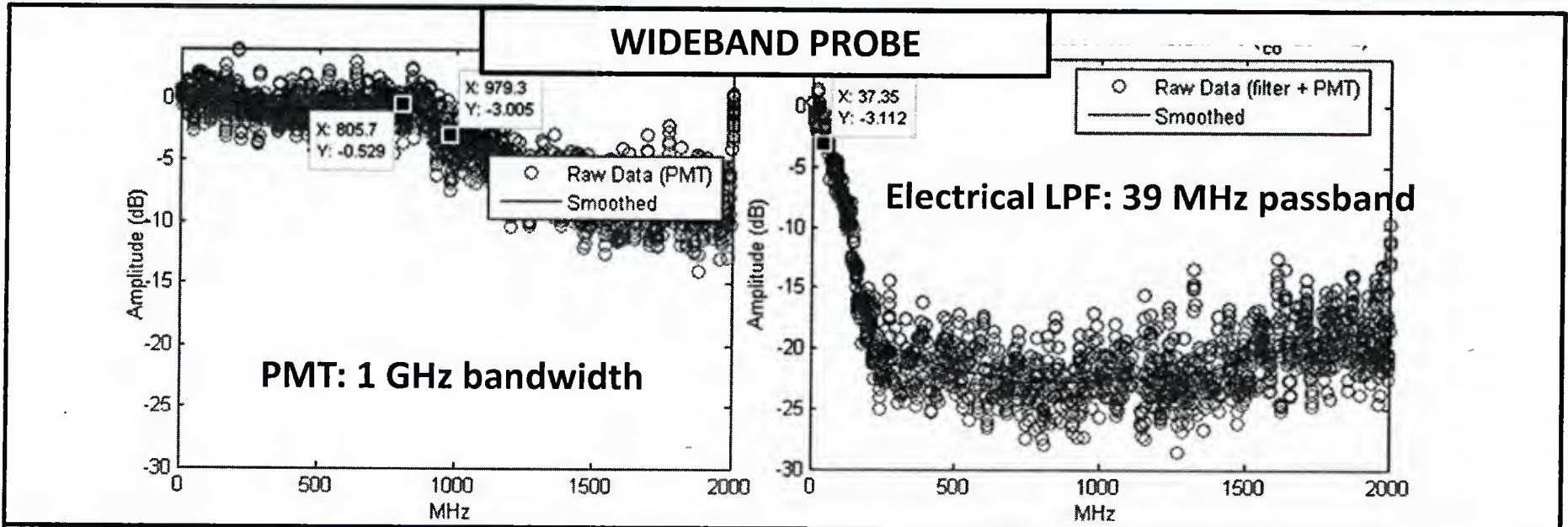

- Design high frequency, scalable power transmitter
- Adaptive receiver to model channel
- Characterize electro-optic components
- Water measurements: Show frequency response of scatter, impact on performance

- New tool for water measurements
  - Motivation for channel identification
  - Internally modulated fiber laser addresses technology challenges for transmitter
  - Adaptive receiver provides usable model of channel