



**NAVAL  
POSTGRADUATE  
SCHOOL**

**MONTEREY, CALIFORNIA**

**THESIS**

**A SYSTEMS ENGINEERING APPROACH TO ALLOCATE  
RESOURCES BETWEEN PROTECTION AND SENSORS FOR  
GROUND SYSTEMS FOR OFFENSIVE OPERATIONS IN AN  
URBAN ENVIRONMENT**

by

Ceying Foo

September 2014

Thesis Co-Advisors:

Douglas Nelson  
Eugene Paulo

**Approved for public release; distribution is unlimited**

THIS PAGE INTENTIONALLY LEFT BLANK

<b>REPORT DOCUMENTATION PAGE</b>			<i>Form Approved OMB No. 0704-0188</i>
Public reporting burden for this collection of information is estimated to average 1 hour per response, including the time for reviewing instruction, searching existing data sources, gathering and maintaining the data needed, and completing and reviewing the collection of information. Send comments regarding this burden estimate or any other aspect of this collection of information, including suggestions for reducing this burden, to Washington headquarters Services, Directorate for Information Operations and Reports, 1215 Jefferson Davis Highway, Suite 1204, Arlington, VA 22202-4302, and to the Office of Management and Budget, Paperwork Reduction Project (0704-0188) Washington, DC 20503.			
<b>1. AGENCY USE ONLY (Leave blank)</b>	<b>2. REPORT DATE</b> September 2014	<b>3. REPORT TYPE AND DATES COVERED</b> Master's Thesis	
<b>4. TITLE AND SUBTITLE</b> A SYSTEMS ENGINEERING APPROACH TO ALLOCATE RESOURCES BETWEEN PROTECTION AND SENSORS FOR GROUND SYSTEMS FOR OFFENSIVE OPERATIONS IN AN URBAN ENVIRONMENT		<b>5. FUNDING NUMBERS</b>	
<b>6. AUTHOR(S)</b> Ceying Foo			
<b>7. PERFORMING ORGANIZATION NAME(S) AND ADDRESS(ES)</b> Naval Postgraduate School Monterey, CA 93943-5000		<b>8. PERFORMING ORGANIZATION REPORT NUMBER</b>	
<b>9. SPONSORING /MONITORING AGENCY NAME(S) AND ADDRESS(ES)</b> N/A		<b>10. SPONSORING/MONITORING AGENCY REPORT NUMBER</b>	
<b>11. SUPPLEMENTARY NOTES</b> The views expressed in this thesis are those of the author and do not reflect the official policy or position of the Department of Defense or the U.S. Government. IRB Protocol number ___N/A___.			
<b>12a. DISTRIBUTION / AVAILABILITY STATEMENT</b> Approved for public release; distribution is unlimited		<b>12b. DISTRIBUTION CODE</b>	
<b>13. ABSTRACT (maximum 200 words)</b>  This thesis describes the effects of using unconventional armor, such as explosive reactive armor, active protection systems, signature management measures, and additional sensing capability in the form of an unmanned aerial vehicle, to improve the survivability and performance of armored platforms in an urban environment during an offensive operation. Variations in the force structure of an armored unit are also examined.  The variation in factors was performed using design of experiments, which generates combinations of different factors to be used in the modeling of the combat scenario using the Map Aware Non-Uniform Automata software. Regression analyses were performed on the results of the simulation using JMP Pro 10, and a combination of factors that were found to be significant were identified for further research and study.  Partition tree analysis was also performed to identify the relative importance of the significant factor combinations with the identification of their respective thresholds. It was discovered that the thickness of conventional armor, the presence of explosive reactive armor, active protection systems, the mobility of the armored vehicles, and the presence a heavy force structure were important to the survivability and performance of the armored platforms. These insights are of importance to military commanders and planners.			
<b>14. SUBJECT TERMS</b> armor, mobility, ERA, APS, Armored Company Team, survivability		<b>15. NUMBER OF PAGES</b> 173	
		<b>16. PRICE CODE</b>	
<b>17. SECURITY CLASSIFICATION OF REPORT</b> Unclassified	<b>18. SECURITY CLASSIFICATION OF THIS PAGE</b> Unclassified	<b>19. SECURITY CLASSIFICATION OF ABSTRACT</b> Unclassified	<b>20. LIMITATION OF ABSTRACT</b> UU

THIS PAGE INTENTIONALLY LEFT BLANK

**Approved for public release; distribution is unlimited**

**A SYSTEMS ENGINEERING APPROACH TO ALLOCATE RESOURCES  
BETWEEN PROTECTION AND SENSORS FOR GROUND SYSTEMS FOR  
OFFENSIVE OPERATIONS IN AN URBAN ENVIRONMENT**

Ceying Foo  
Major, Republic of Singapore Army  
B.Eng, National University of Singapore, 2009

Submitted in partial fulfillment of the  
requirements for the degree of

**MASTER OF SCIENCE IN SYSTEMS ENGINEERING**

from the

**NAVAL POSTGRADUATE SCHOOL  
September 2014**

Author: Ceying Foo

Approved by: Douglas Nelson  
Thesis Co-Advisor

Eugene Paulo  
Thesis Co-Advisor

Clifford Whitcomb  
Chair, Department of Systems Engineering

THIS PAGE INTENTIONALLY LEFT BLANK

## **ABSTRACT**

This thesis describes the effects of using unconventional armor, such as explosive reactive armor, active protection systems, signature management measures, and additional sensing capability in the form of an unmanned aerial vehicle, to improve the survivability and performance of armored platforms in an urban environment during an offensive operation. Variations in the force structure of an armored unit are also examined.

The variation in factors was performed using design of experiments, which generates combinations of different factors to be used in the modeling of the combat scenario using the Map Aware Non-Uniform Automata software. Regression analyses were performed on the results of the simulation using JMP Pro 10, and a combination of factors that were found to be significant were identified for further research and study.

Partition tree analysis was also performed to identify the relative importance of the significant factor combinations with the identification of their respective thresholds. It was discovered that the thickness of conventional armor, the presence of explosive reactive armor, active protection systems, the mobility of the armored vehicles, and the presence a heavy force structure were important to the survivability and performance of the armored platforms. These insights are of importance to military commanders and planners.

THIS PAGE INTENTIONALLY LEFT BLANK

# TABLE OF CONTENTS

<b>I.</b>	<b>INTRODUCTION.....</b>	<b>1</b>
	<b>A. BACKGROUND .....</b>	<b>1</b>
	<b>B. PROBLEM STATEMENT .....</b>	<b>1</b>
	<b>C. RESEARCH QUESTIONS .....</b>	<b>2</b>
	<b>D. SURVIVABILITY CONCEPT .....</b>	<b>3</b>
	<b>E. VULNERABILITY CONCEPT .....</b>	<b>5</b>
	<b>F. SUSCEPTIBILITY CONCEPT .....</b>	<b>5</b>
	<b>G. WHY THE URBAN OPERATIONS SCENARIO? .....</b>	<b>5</b>
<b>II.</b>	<b>SYSTEMS ENGINEERING APPROACH .....</b>	<b>7</b>
	<b>A. BOUNDARIES AND INTERACTIONS .....</b>	<b>7</b>
	<b>B. STAKEHOLDER ANALYSIS .....</b>	<b>10</b>
	<b>C. ARCHITECTURE .....</b>	<b>12</b>
	<b>1. Operational Architecture .....</b>	<b>15</b>
	<b>2. Functional Architecture .....</b>	<b>17</b>
	<b>D. MEASURES OF EFFECTIVENESS.....</b>	<b>22</b>
	<b>1. Percentage BLUE Casualties .....</b>	<b>24</b>
	<b>2. Force Exchange Ratio (FER) .....</b>	<b>24</b>
	<b>3. Probability of Completing Mission.....</b>	<b>25</b>
	<b>4. Time Steps Taken to Complete Mission.....</b>	<b>25</b>
<b>III.</b>	<b>SYSTEMS ANALYSIS METHODOLOGY .....</b>	<b>27</b>
	<b>A. TYPES OF MODELS AND SIMULATIONS.....</b>	<b>27</b>
	<b>B. MAP AWARE NON-UNIFORM AUTOMATA (MANA) .....</b>	<b>28</b>
	<b>1. Advantages of MANA.....</b>	<b>29</b>
	<b>2. Disadvantages of MANA .....</b>	<b>30</b>
	<b>C. FACTORS SELECTION .....</b>	<b>31</b>
	<b>1. Passive Armor Thickness Percentage .....</b>	<b>34</b>
	<b>2. Presence of Active Protection System (APS) .....</b>	<b>35</b>
	<b>3. Presence of Explosive Reactive Armor (ERA) .....</b>	<b>36</b>
	<b>4. Mobility Percentage .....</b>	<b>37</b>
	<b>5. Signature Management Measures .....</b>	<b>38</b>
	<b>6. Presence of Additional Sensor (UAV) .....</b>	<b>39</b>
	<b>7. Force Structure .....</b>	<b>40</b>
	<b>D. DESIGN OF EXPERIMENTS .....</b>	<b>41</b>
	<b>E. DATA FARMING AND ANALYSIS.....</b>	<b>44</b>
<b>IV.</b>	<b>COMBAT OPERATIONS .....</b>	<b>45</b>
	<b>A. OFFENSIVE OPERATIONS .....</b>	<b>45</b>
	<b>B. MISSION SETS OF OFFENSIVE OPERATIONS .....</b>	<b>45</b>
	<b>C. URBAN ENVIRONMENT .....</b>	<b>46</b>
	<b>D. GROUND PLATFORMS OVERVIEW .....</b>	<b>47</b>
	<b>1. BLUE Forces .....</b>	<b>47</b>
	<b>b. Infantry Carrying Vehicles (ICV) .....</b>	<b>49</b>

	2.	Threats .....	50
E.		PROTECTION.....	52
	1.	Passive Protection .....	52
	2.	Active Protection.....	52
		a. <i>Hard Kill Active Protection System</i> .....	53
		b. <i>Explosive Reactive Armor (ERA)</i> .....	54
F.		SENSORS .....	54
G.		FORCE STRUCTURE OF ARMORED COMPANY TEAM .....	55
V.		SCENARIO MODELING.....	57
	A.	HYPOTHETICAL OPERATIONAL SCENARIO.....	57
	B.	REAL LIFE REFERENCE .....	59
	C.	OPERATIONAL ORDERS.....	59
		1. Terrain .....	61
		2. Enemy Situation .....	62
		3. Friendly Situation .....	62
		4. Mission .....	63
		5. Execution .....	63
	D.	CONDITIONS FOR MISSION SUCCESS.....	64
		1. Destruction of 50% of Enemy (RED) Forces .....	64
		2. Isolation of Enemy Forces by Capturing the Two Bridges across the River .....	64
	E.	AGENTS SUMMARY.....	65
VI.		RESULTS ANALYSIS .....	67
	A.	INDICATORS OF SIGNIFICANCE OF RESULTS .....	67
		1. R <sup>2</sup> Value .....	69
		2. t-Statistic .....	69
	B.	INITIAL SIMULATION RESULTS .....	70
		b. <i>Force Exchange Ratio</i> .....	74
		c. <i>Probability of Completing Mission</i> .....	77
		d. <i>Time Steps taken to Complete Mission</i> .....	80
		e. <i>Most Important Main Effects</i> .....	83
		f. <i>Insignificant Factors</i> .....	83
	C.	REFINED SIMULATION RESULTS .....	84
		1. Pair Wise Analysis of Results Based on MOEs.....	85
		a. <i>Percentage BLUE Casualties</i> .....	85
		b. <i>Force Exchange Ratio (FER)</i> .....	90
		c. <i>Time Steps Taken to Complete Mission</i> .....	98
		2. MOE Equations.....	104
		a. <i>MOE Equation Insights</i> .....	104
		3. Partition Tree Analysis for Insights on MOEs.....	105
		a. <i>Percentage BLUE Casualties Insight</i> .....	107
		b. <i>Force Exchange Ratio (FER) Insights</i> .....	111
		c. <i>Probability of Completing Mission Insights</i> .....	115
		d. <i>Time Steps Taken to Complete Mission Insights</i> .....	119
		e. <i>Insights Summary</i> .....	123

<b>VII. CONCLUSION .....</b>	<b>126</b>
<b>A. SUMMARY AND CONCLUSIONS .....</b>	<b>126</b>
<b>B. FUTURE WORK .....</b>	<b>128</b>
<b>APPENDIX A. MODEL PARAMETERS .....</b>	<b>131</b>
<b>APPENDIX B. DESIGN OF EXPERIMENTS AND SIMULATION RESULTS .....</b>	<b>133</b>
<b>A. INITIAL SIMULATION DESIGN POINTS GENERATED USING MINITAB AND SIMULATION RESULTS .....</b>	<b>133</b>
<b>B. REFINED SIMULATION DESIGN POINTS GENERATED USING NOLH MINITAB AND SIMULATION RESULTS.....</b>	<b>137</b>
<b>LIST OF REFERENCES .....</b>	<b>143</b>
<b>INITIAL DISTRIBUTION LIST .....</b>	<b>147</b>

THIS PAGE INTENTIONALLY LEFT BLANK

## LIST OF FIGURES

Figure 1.	Survivability Onion concept (from Kempinski and Murphy 2012).....	3
Figure 2.	Global urbanization trend (from United Nations 2012).....	6
Figure 3.	Operational View-2 for the Armored Company Team.....	8
Figure 4.	Interest and influence matrix of the Armored Company Team stakeholders.....	11
Figure 5.	Capabilities of Armored Company Team.....	14
Figure 6.	Operational View 5a - Operational Activity decomposition tree of the Armored Company Team.....	16
Figure 7.	Functional architecture of Armored Company Team.....	18
Figure 8.	Mapping of functions of the Armored Company Team to respective Operational Activities – Part 1.....	19
Figure 9.	Mapping of functions of the Armored Company Team to respective Operational Activities – Part 2.....	20
Figure 10.	Mapping of functions of the Armored Company Team to respective Operational Activities – Part 3.....	21
Figure 11.	Mapping of Operational Activities to respective MOEs.....	23
Figure 12.	Modeling and simulation pyramid and broad characteristics (from Coolahan 2003).....	27
Figure 13.	Tracing of Design Factors to Functional Architecture of the Armored Company Team.....	33
Figure 14.	Increase of Armor Thickness on Vehicles since the Conception of Armored Warfare (from Yap 2012).....	35
Figure 15.	Trophy APS Intercepting an Incoming Hostile Projectile (from Armada 2013).....	36
Figure 16.	M2 Bradley AFV Mounted with ERA Cassettes (from Osborn 2007).....	37
Figure 17.	Thermo-Variable Tiles Mounted on a Combat Vehicle (CV) – 90 (from Armada 2013).....	38
Figure 18.	The center picture demonstrates the vast reduction in the vehicle’s thermal and infrared red signature with the employment of Signature Management Measures in the form of Thermo-Variable tiles (from Armada 2013).....	39
Figure 19.	RQ-11 RAVEN UAV.....	39
Figure 20.	NOLH for the final simulation runs.....	43
Figure 21.	M1A2 Main Battle Tank (from Yap 2012).....	48
Figure 22.	M2 Bradley AFV (from Yap 2012).....	49
Figure 23.	Stryker Infantry Carrying Vehicle (from Army Technology 2013).....	50
Figure 24.	Chronology of events for the functioning of a generic Hard-Kill Active Protection System (from Treml 2013).....	53
Figure 25.	APS (Trophy) mounted on a Merkava Mk 3 of the Israel Defense Forces (from Armada 2013).....	54
Figure 26.	Initial layout of BLUE and RED Forces for the simulation of an attack operation by an Armor Combat Team to capture an urban objective using MANA.....	58

Figure 27.	Operations overlay for the scenario. ....	60
Figure 28.	JMP output example. ....	68
Figure 29.	Initial regression results for MOE - % BLUE Casualties. ....	72
Figure 30.	Parameter estimates for MOE – % BLUE Casualties. ....	73
Figure 31.	Initial regression results for MOE – FER. ....	75
Figure 32.	Parameter estimates for MOE – FER. ....	76
Figure 33.	Initial regression results for MOE – Probability of Completing Mission. ....	78
Figure 34.	Parameter estimates for MOE – Probability of Completing Mission. ....	79
Figure 35.	Initial regression results for MOE – Time steps taken to Complete Mission. ....	81
Figure 36.	Parameter estimates for MOE – Time steps taken to Complete Mission. ....	82
Figure 37.	Pair-wise regression results for MOE - % BLUE Casualties. ....	86
Figure 38.	Effects of the factors and combinations on MOE - % BLUE Casualties. ....	87
Figure 39.	Pair-wise regression results for MOE – FER. ....	91
Figure 40.	Effects of the factors and combinations on MOE – FER. ....	92
Figure 41.	Pair-wise regression results for MOE–Probability of Completing Mission. ....	95
Figure 42.	Effects of the factors and combinations on MOE–Probability of Completing Mission. ....	96
Figure 43.	Pair-wise regression results for MOE – Time step taken to Complete Mission. ....	99
Figure 44.	Effects of the factors and combinations on MOE – Time steps taken to Complete Mission. ....	100
Figure 45.	Partition tree analysis of MOE – % BLUE Casualties. ....	107
Figure 46.	MOE #1 factors of combination of choice – Combination 1. ....	108
Figure 47.	Combination 1 – Comparison of outcome of MOE #1 with the presence and absence of Explosive Reactive Armor. ....	108
Figure 48.	Combination 1 – Comparison of outcome of MOE #1 with the presence and absence of Active Protection System. ....	109
Figure 49.	Combination 2 – Comparison of outcome of MOE #1 with difference in Armor Thickness percentage. ....	110
Figure 50.	Combination 2 – Comparison of outcome of MOE #1 with difference in Force Structure. ....	110
Figure 51.	Partition tree analysis of MOE – FER. ....	111
Figure 52.	MOE #2 factors of combination of choice – Combination 1. ....	112
Figure 53.	Combination 1 – Comparison of outcome of MOE #2 with the difference in Force Structure. ....	112
Figure 54.	Combination 1 – Comparison of outcome of MOE #2 with the difference in Armor Thickness percentage. ....	113
Figure 55.	Combination 2 – Comparison of outcome of MOE #2 with the presence and absence of Explosive Reactive Armor and Active Protection System. ....	113
Figure 56.	Combination 2 – Comparison of outcome of MOE #2 with the difference in Mobility percentage. ....	114
Figure 57.	Partition tree analysis of MOE – Probability of Completing Mission. ....	115
Figure 58.	MOE #3 factors of combination of choice – Combination 1. ....	116
Figure 59.	Combination 1 – Comparison of outcome of MOE #3 with the presence and absence of Explosive Reactive Armor. ....	116

Figure 60.	Combination 1 – Comparison of outcome of MOE #3 with the difference in Force Structure.....	117
Figure 61.	Combination 2 – Comparison of outcome of MOE #3 with the difference in Force Structure.....	118
Figure 62.	Combination 2 – Comparison of outcome of MOE #3 with the difference in Armor Thickness percentage. ....	118
Figure 63.	Partition tree analysis of MOE – Time steps taken to Complete Mission. ....	119
Figure 64.	MOE #4 factors of combination of choice – Combination 1 .....	120
Figure 65.	Combination 1 – Comparison of outcome of MOE #4 with the difference in Mobility percentage. ....	120
Figure 66.	Combination 1 – Comparison of outcome of MOE #4 with the difference in Force Structure.....	121
Figure 67.	Combination 1 – Comparison of outcome of MOE #4 with the presence and absence of Explosive Reactive Armor. ....	121
Figure 68.	Combination 1 – Comparison of outcome of MOE #4 with the difference in Mobility percentage. ....	122
Figure 69.	Combination 2 – Comparison of outcome of MOE #4 with the presence and absence of Explosive Reactive Armor. ....	123

THIS PAGE INTENTIONALLY LEFT BLANK

## LIST OF TABLES

Table 1.	Stakeholders analysis of the Armored Company Team.....	10
Table 2.	Summary of advantages and disadvantages of MANA. ....	29
Table 3.	Summary of the Seven Factors Variations and the Resultant Effects. ....	34
Table 4.	Force Structure of the Armored Company Team and its associated number of vehicles. ....	41
Table 5.	Military symbols and their meanings.....	59
Table 6.	Summary of agents used in the simulations.....	65
Table 7.	Summary of design factors that are significant in determining the outcome of the respective MOEs based on t-statistic values (Green = Very Significant, Yellow = Significant, Orange = Not so Significant, Red = Not Significant).....	83
Table 8.	Summary of the effect of the factors and various factors combinations on the MOEs (Green = Beneficial, Red = Detrimental, Black = N/A).....	103
Table 9.	Summary of the importance of the factors and their threshold values on the MOEs. ....	124
Table 10.	MANA input parameters.....	131
Table 11.	Initial DOE and results – Part 1. ....	133
Table 12.	Initial DOE and results – Part 2. ....	134
Table 13.	Initial DOE and results – Part 3. ....	135
Table 14.	Initial DOE and results – Part 4. ....	136
Table 15.	Refined DOE and results – Part 1. ....	137
Table 16.	Refined DOE and results – Part 2. ....	138
Table 17.	Refined DOE and results – Part 3. ....	139
Table 18.	Refined DOE and results – Part 4. ....	140
Table 19.	Refined DOE and results – Part 5. ....	141

THIS PAGE INTENTIONALLY LEFT BLANK

## LIST OF ACRONYMS AND ABBREVIATIONS

AFV	Armored Fighting Vehicle
AO	Area of Operations
APFSDS-T	Armored Piercing Fin Stabilized Discarding Sabot
APS	Active Protection System
ATGM	Anti-Tank Guided Missile
BDA	Battlefield Damage Assessment
DOD	Department of Defense
DOE	Design of Experiments
ERA	Explosive Reactive Armor
FER	Force Exchange Ratio
FSO	Full Spectrum Operations
HHS	High Hardness Steel
IED	Improvised Explosive Device
ICV	Infantry Carrying Vehicle
ISR	Intelligence, Surveillance and Reconnaissance
HEAT	High Explosive Anti-Tank
MANA	Map Aware Non-uniform Automata
MBT	Main Battle Tank
MOE	Measure of Effectiveness
NLT	No Later Than
NOLH	Nearly Orthogonal Latin Hypercube
RHA	Rolled Homogeneous Armor
RPG	Rocket Propelled Grenade
SITREP	Situation Report
TOW	Tube-Launched, Optically-Tracked, Wire-Guided
TRL	Technology Readiness Level
UAV	Unmanned Aerial Vehicle

THIS PAGE INTENTIONALLY LEFT BLANK

## **EXECUTIVE SUMMARY**

With the proliferation of asymmetrical threats and the advancement of conventional threats to armored ground vehicles, the traditional method of improving protection and survivability of armored vehicles by adding metal has dramatically decreased in its effectiveness. In addition, the global trend of conflicts and battles taking place in the urban environment is inevitable. It is envisioned by many military thinkers and scholars that the majority of future conflicts will take place in an urban setting. Furthermore, the expanded mission sets that are required of armored forces dictate the requirement of a force with high survivability in order to perform the myriad of tasks required.

Hence, this study addresses the allocation of resources to improve survivability, via a combination of conventional and asymmetric means, of armored vehicles in an offensive operation in an urban environment, and it is done in the context of an Armored Company Team.

The study has taken the following approach and methodology:

(1) Systems Engineering Approach

A systems engineering approach has been applied initially to define the boundaries of the problems and to identify the respective stakeholders. The operational and functional architectures required by an Armored Company Team are also defined. This allows the identification of four important Measures of Effectiveness (MOE), namely Percentage of BLUE Casualties, Force Exchange Ratio, Probability of Completing Mission, and Time Steps taken to Complete Mission.

(2) Analysis Methodology

Agent-based simulation is the analysis tool used in the study. The simulation software of choice is Map Aware Non-Uniform Automata (MANA) software developed by the New Zealand Defense Force. A robust design of experiments is then conducted for both the initial and refined simulation runs to generate sets of comprehensive design points for the study.

### (3) Combat Operations and Scenario

The various mission sets required for the conduct of Offensive Operations by an Armored Company Team, along with the characteristics of the urban environment, are established. A review of the present capabilities and makeup of both the BLUE forces and the associated threats are conducted. These, along with a description of the scenario and a truncated version of the typical operational orders, provide reference for the study and simulation.

### (4) Factor Selection

The factors that are identified for variation and study in the simulation include: Armor Thickness Percentage, Presence of Active Protection System, Presence of Explosive Reactive Armor, Mobility Percentage, Presence of Signature Management Measures, Presence of Additional Sensor and Force Structure.

### (5) Results Analysis

The results of the simulations are analyzed using the statistical software, JMP Pro 10. It was revealed that only the following factors were significant to the four MOEs: Armor Thickness Percentage, Presence of Active Protection System, Presence of Explosive Reactive Armor, Mobility Percentage, and Force Structure.

Further analysis on these factors was done and it yielded a set of equations that allows the prediction of the outcome of the four MOEs. A partition tree was also obtained for each MOE where the relative importance and threshold values of the factors were identified.

### (6) Conclusion and Recommendations

The findings of this study would enable the military commanders and planners to have an indication, based on the four MOEs, of the outcome of their conduct of offensive operations in an urban environment using an Armored Company Team. In addition, the identification of the important factors sets the direction for the investment of resources to upgrade current armored vehicles or in the design of the next generation of armored vehicles in order to improve their survivability.

Future research should address the following areas.

- Setting the scenario in a different environment and type of operation.
- Using a more robust design of experiments and using other simulation software, such as COMBAT XXI, to further expand and validate the current findings.
- Using the actual values for the attributes of the armored vehicles in simulation as the current values are derived from open sources and may deviate from the actual classified values.

THIS PAGE INTENTIONALLY LEFT BLANK

## **ACKNOWLEDGMENTS**

I would like to express my sincere appreciation to Associate Professor Douglas Nelson and Associate Professor Eugene Paulo for their patient instruction and constant encouragement. They shared a wealth of knowledge and it was my privilege to work with them. Their guidance and kind support had spurred me on. In addition, I am grateful to Senior Lecturer Gregory Miller for his efforts as my second reader.

I thank Ms. Mary McDonald for her unwavering support and for sacrificing much of her precious time to guide me in the use of the simulation software, MANA, which was instrumental to the conduct of this study. Special thanks to the authors of various books, articles, and journals, which provided much useful information and insights.

My gratitude also extends to the Singapore Armed Forces for putting their faith in me and providing me this opportunity.

Last but not least, to my wife, Wendy, for becoming my pillar of strength.

THIS PAGE INTENTIONALLY LEFT BLANK

# **I. INTRODUCTION**

## **A. BACKGROUND**

War has been present throughout the history of mankind. As mankind engages in conflict, the idea of protecting oneself remains central in mankind's evolution and progress. In the early ages, armor started out as merely thick hides or leather that was draped over the body for protection. As human kind evolved, the armor employed became progressively more effective and sophisticated.

Armor such as chain mail and iron plates left their mark in history as the cutting edge protection system of their time. As technology advanced, the need for protection gradually extended from the infantry soldiers and animals, such as war horses, to vehicles and equipment. The thundering of the British-made Mark 1 tanks across the infantry trenches during the Battle of the Somme on 15 September 1916 heralded in the age of armored warfare (Yap 2012).

Since then, having seen the value and decisiveness of armored vehicles and tanks on the battlefield, the preoccupation of the armies of the world has been to improve the lethality of the armored vehicles in their military inventory, as well as to improve the armor protection of the vehicles. This technological race has especially been evident during and after major modern conflicts like the Second World War, the Yom Kippur War of 1973, Operation Desert Storm in 1991, and Operation Iraqi Freedom in 2003.

However, the improvement of armor protection by adding on more metal as passive armor is unlikely to keep pace with the development of the anti-armor weapons. Hence, asymmetrical ways of improving armor protection must be sought to improve survivability of the armored vehicles in a combat environment.

## **B. PROBLEM STATEMENT**

With the rapid advancement of anti-armor weapon penetration capability, the traditional approach to mitigate the threat by simply adding more armor on tanks and armored vehicles has become progressively ineffective as it approaches the physical

limitation of the sheer amount of armor that can be mounted on a vehicle for it to navigate terrain and fight effectively in its area of operations.

In addition, with the current capability of the armor to withstand the penetration threat, is there a further need to bolster its armor protection to improve its combat survivability? Conversely, would it be more worthwhile to invest resources in asymmetric protection such as sensor capabilities to better detect and hence actively engage or avoid the threat to improve survivability?

This thesis aims to determine the allocation of resources among the procurement of more armor protection for the ground systems (to better defeat the threat or survive a hit), improvement of the ground platforms' mobility as a form of passive defense, and the procurement of more sensor capabilities to detect the threat earlier (to better defeat the threat or evade it). The context of the research will be focused on an offensive operation in a hypothetical combat environment and involves three classes of ground platforms, namely main battle tank, armored fighting vehicle (tracked), and infantry carrying vehicle (wheeled).

Specifically, this thesis will focus on the operations of an Armored Company Team, which is comprised of a company of nine to 12 armored vehicles, based on its force structure of a mixture main battle tanks, armored fighting vehicles, or infantry carrying vehicles.

### **C. RESEARCH QUESTIONS**

The following research questions guided the direction of the research for this study.

1. What are the primary design factors for a ground combat vehicle in order to achieve mission success and survivability in offensive operations in an urban environment?
2. How does the tradeoff of one parameter affect the platform's survivability and performance as a whole?
3. What is the relative importance of attributes on the platform?

## D. SURVIVABILITY CONCEPT

The concept of combat survivability is often encapsulated in the form of a Survivability Onion (Kempinski and Murphy 2012) which serves to illustrate and enhance the survivability design of a combat system based on several “onion-like” layers, with the innermost layer being the most important. Figure 1. is an illustration of the survivability onion concept.

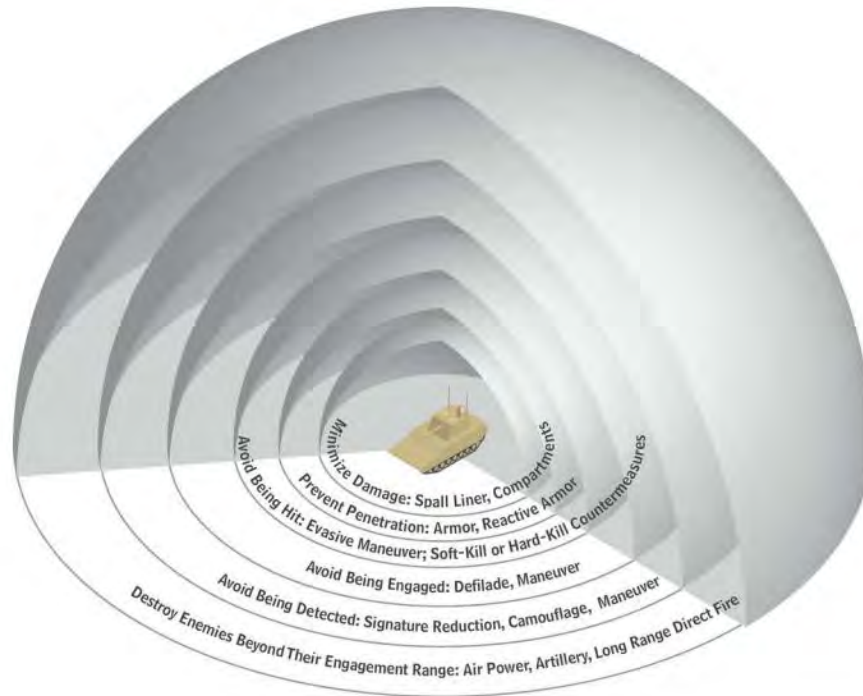

Figure 1. Survivability Onion concept (from Kempinski and Murphy 2012).

### (1) Destroy Enemy beyond their Engagement Range

This is the outermost layer of the Survivability Onion and it addresses the concept of engaging and destroying the enemy before the enemy can engage the friendly forces, thereby preventing the friendly forces from being engaged and destroyed by the enemy. The force of choice normally consists of long range strike capability such as air power and artillery pieces, which is beyond that of an armored company team.

(2) Avoid Being Detected

This layer of the onion deals with two factors, signature reduction and enhancing situation awareness. Signature reduction refers to reducing the “tell-tale” signs of the presence of an armored vehicle, such as the vehicle’s infrared emissions, while enhancing situation awareness for the armored vehicle allows it to sense and detect the presence of enemy more effectively and take evasive measures to avoid it if necessary. These two factors enhance the system’s survivability by reducing the probability of the armored vehicle being detected by enemy forces.

(3) Avoid Being Engaged

This layer addresses the likelihood of a system being targeted and tracked by an adversary. It involves using terrain and obstacles, along with tactical maneuvers, to prevent being engaged or fired upon by the enemy.

(4) Avoid Being Hit

This layer addresses the probability of the system being hit after being seen and acquired by the enemy. It utilizes the Soft Kill, which includes measures such as electronic spoofing that prevents the incoming threat from remaining locked onto the armored vehicle and thereby failing to hit it. It also utilizes the Hard Kill, which includes measures that actively detect and destroy the incoming threat by firing projectiles to intercept the threat (Kempinski and Murphy 2012). Both types of measures enhance its survivability.

(5) Prevent Penetration

This layer deals with the likelihood of a system being penetrated by a projectile after it is hit. It depends on its active protection and base layer of passive armor for system survival.

(6) Minimize Damage

This is the innermost layer of the onion and it addresses the probability of a system being killed or destroyed after being penetrated. All its defenses and protection

suites have already been rendered ineffective and it depends on system design to limit the damage sustained and improve survivability (Trembl 2013).

#### **E. VULNERABILITY CONCEPT**

Vulnerability is the inability of the system to withstand damage in a hostile environment. It is the liability to sustain serious damage that results in a mission kill or destruction when hit by enemy fire (Trembl 2013).

Vulnerability is largely influenced by the following factors:

1. Size, number, and type of projectiles that impact the system
2. System design

#### **F. SUSCEPTIBILITY CONCEPT**

Susceptibility is defined as the inability of the system to avoid being damaged by mechanisms generated by a hostile environment. Susceptibility of a system is influenced by the following factors (Trembl 2013):

1. Threat characteristics, operations, and effectiveness
2. System's signature, countermeasures, and protection suites
3. The encounter scenario between the system and the threat

#### **G. WHY THE URBAN OPERATIONS SCENARIO?**

There is no doubt that our world is being urbanized more comprehensively than ever before, with the urban population being expected to reach 6.3 billion in the year 2050 (United Nations 2012). As illustrated in Figure 2, the percentage of world population that resides in an urban environment has increased from 29.4% in 1950 to a projected value of 67.2% in 2050.

An increasing number of people are being crammed into cities and urban environments with ill-equipped infrastructure to handle such an influx of people. Hence, competition for resources and security will ensue. Under these stresses and conditions, the simmering ethnic and economic tension can explode and precipitate into a flashpoint of violence that requires military intervention (Krulak 1999).

<i>Development group</i>	<i>Percentage urban</i>					<i>Rate of urbanization</i>			
						<i>(percentage)</i>			
	<i>1950</i>	<i>1970</i>	<i>2011</i>	<i>2030</i>	<i>2050</i>	<i>1950-1970</i>	<i>1970-2011</i>	<i>2011-2030</i>	<i>2030-2050</i>
World.....	29.4	36.6	52.1	59.9	67.2	1.09	0.86	0.74	0.57
More developed regions.....	54.5	66.6	77.7	82.1	85.9	1.01	0.38	0.29	0.23
Less developed regions.....	17.6	25.3	46.5	55.8	64.1	1.81	1.48	0.95	0.69

Figure 2. Global urbanization trend (from United Nations 2012).

It is no coincidence that urban terrains are the battlefield of choice by militaries that are less technologically advanced. The network of roads and houses serves to negate the military advantages of the technologically advanced forces as it denies these forces the freedom to use their weaponry to engage and destroy targets efficiently and effectively (Graham 2009).

As this global trend suggests, there is no doubt that the future of military combat and warfare lies in the urban environment, where it is dominated by streets, buildings, and houses. The importance of urban military operations is highlighted in the “Three Blocks War” theory (Krulak 1999). Thus, it is unavoidable that military combat operations in urban environments are of great concern to the defense community and have markedly increased in importance in recent times (Peters 1996).

## **II. SYSTEMS ENGINEERING APPROACH**

The research on the identified problem is framed using a systems engineering approach, whereby the boundaries of the problem and the key stakeholders are identified. The architecture of the Armored Company Team was analyzed and the important Measures of Effectiveness (MOEs) were determined (SE Handbook Working Group 2010).

### **A. BOUNDARIES AND INTERACTIONS**

The Armored Company Team is expected to interact with numerous external systems that exist within its area of operations. The external systems are namely the Command Element of the Armored Company Team, Enemy Platforms, Intelligence Elements, Friendly Forces, and the Environment. The Operational View-2 (Operational Resource Flow Description) for the boundaries and interaction of the Armored Company Team is illustrated in Figure 3.

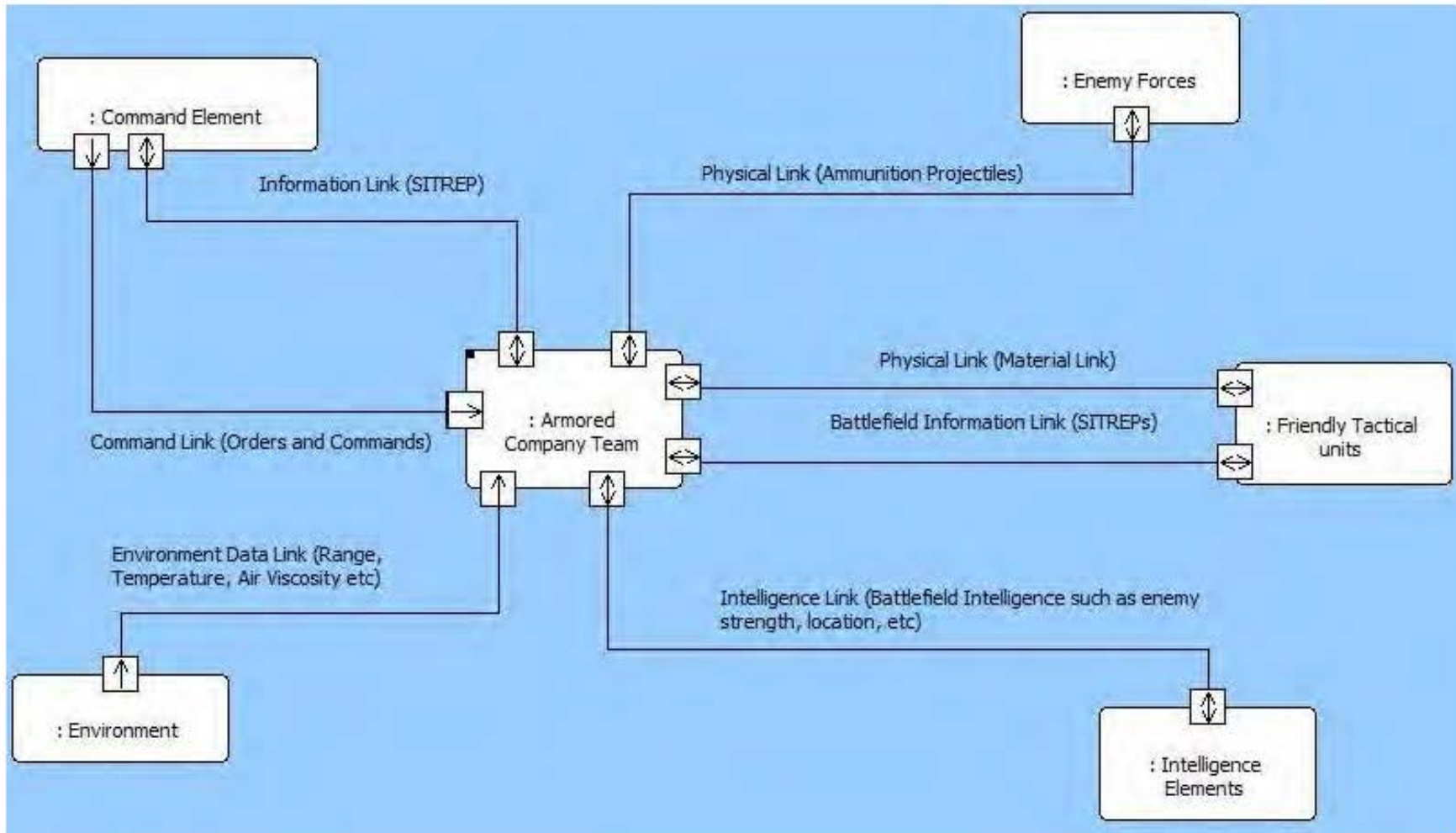

Figure 3. Operational View-2 for the Armored Company Team

(1) Command Element

The Command Element is expected to interact with the Armored Company Team via a Command Link where orders and commands can be issued to the tactical units from higher echelons. In addition, an Information Link exists between the Command Element, which is the higher echelon, and the Armored Company Team where information regarding the battle can be actively conveyed and shared via Situation Reports (SITREPs).

(2) Enemy Platforms

The interaction between the Armored Company Team and the Enemy units is via a Physical Link where they attempt to engage and destroy each other using physical projectiles and weaponry.

(3) Intelligence Elements

The Armored Company Team interacts with the Intelligence Elements via an information link where the intelligence data regarding the battle and mission are exchanged.

(4) Friendly Forces

The Armored Company Team interacts with the other friendly tactical units via a Physical link (where the transfer of materials such as food, water, ammunition, and equipment occurs) and a Battlefield Information Link where the data and information regarding the battle is exchanged.

(5) Environment

The system can sense and measure from the environment information such as the temperature, air viscosity, and wind speed to the Armored Company Team for processing by its fire control computer in order to derive a firing solution for its weapon system.

**B. STAKEHOLDER ANALYSIS**

The stakeholders that are involved in the Armored Company Team are the U.S. Department of Defense (DOD), the U.S. Army, and the crew for the Armored Company Team, and the industry that will design and build the system. The various needs, goals, and objectives of the stakeholders are listed in Table 1.

Table 1. Stakeholders analysis of the Armored Company Team

S/N	STAKEHOLDERS	TYPE	NEEDS	GOALS	OBJECTIVES
1	US Department of Defense (DoD)	Sponsor	To have the capability to win any ground military operations.	To successfully win any ground military operations.	To have a tactically superior ground platform.
2	U.S. Army	High Level User	To support the US DoD.	To win the ground military operations.	To accomplish any given missions.
3	Armored Company Team Crew	Direct User	To have a superior armor platform against the enemy's platform.	To accomplish mission.	To destroy enemy forces and survive the engagement.
4	Industry	Developer	To earn and generate profit to sustain the industry.	To become the manufacturer of the Armored Company Team.	To design and built the Armored Company Team at an economical and effective manner.
5	Enemy	Adversary	To maintain at least tactical parity with that of the BLUE forces' ground forces.	To defeat or prevent defeat by the BLUE forces in any military operations.	To have a ground platform of at least tactical parity with that of the BLUE forces' ground platform.

The prioritization of the stakeholders was carried out using an Interest and Influence matrix as part of the stakeholders’ analysis as illustrated in **Error! Reference source not found.**The stakeholders were categorized into four groups—Engage Actively, Keep Satisfied, Keep Informed, and Monitor—based on their respective influence over the system as well as their interest in the system.

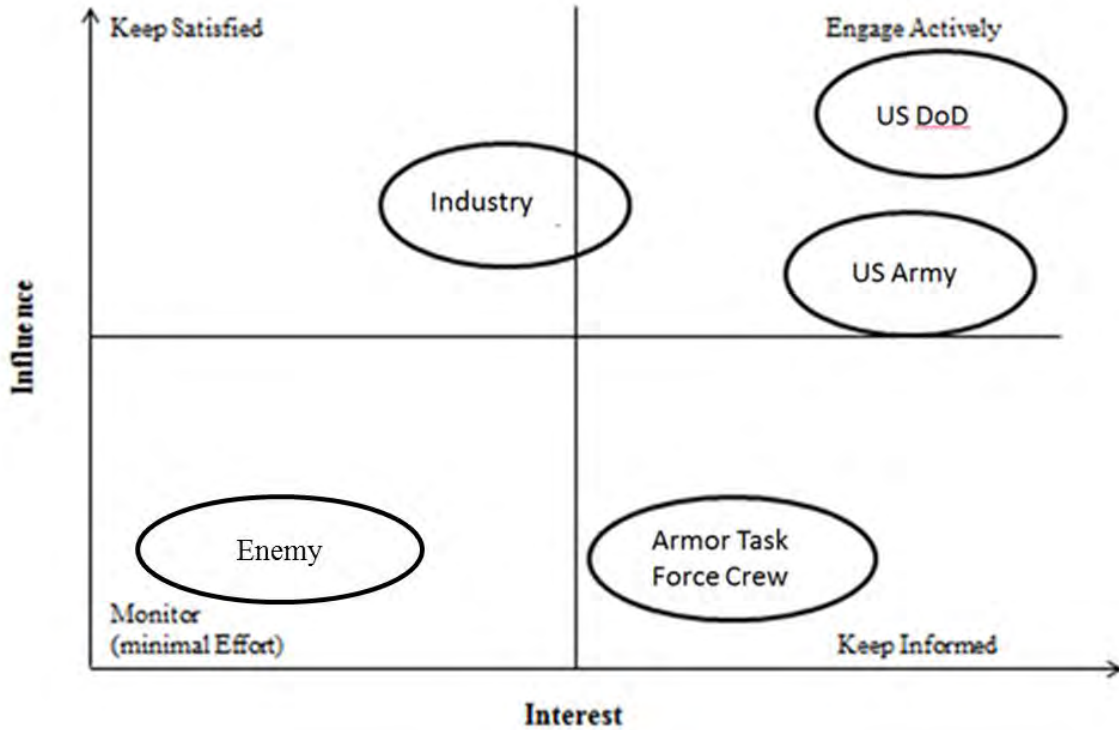

Figure 4. Interest and influence matrix of the Armored Company Team stakeholders.

The stakeholders were arranged in descending order of priority as follows:

- (1) Engage Actively

The U.S. DOD and U.S. Army are classified under the category of “Engage Actively” as they are the important stakeholders of the Armored Company Team. The U.S. DOD, with its responsibility of defending the nation with military might, has the overall authority and interest in the Armored Company as it needs a tactically superior ground platform to win any ground military operations. Hence, it has the most interest and influence over the design of an Armored Company Team.

The U.S. Army is a subset of the U.S. DOD. It fulfills the commands and needs of the U.S. DOD by having the capability of winning ground military operations. Likewise, in order to do so, it requires tactically superior ground platforms. Thus, it has as much interest as the U.S. DOD but lesser influence due to its lower hierarchy.

(2) Keep Satisfied

The military industry that produces and designs the Armored Company Team has an interest in the design of the Armored Company Team. As a private contractor and manufacturer, it has substantial influence on the Armored Company Team, and hence, it is being classified under the “Keep Satisfied” category.

(3) Keep Informed

The Armored Company Team crew members have a lot of interest in having a tactically superior ground platform as they live and die with the platform they operate in during a military operation. It is in their interest to have a tactically superior platform to enhance their chances of victory and survival. However, being the end user, they have less influence, as compared to the DOD and U.S. Army, over the design of the Armored Company Team and hence are classified into the “Keep Informed” category.

(4) Monitor

The enemy will always try its best to outperform the BLUE forces. The enemy will always strive to have the tactical edge over the BLUE forces. However, it does not have direct influence over the Armored Company Team. At the same time, it is also necessary to keep track of the technological advancement of the enemy’s arsenal. Hence, the enemy is being classified into the “Monitor” category.

**C. ARCHITECTURE**

The architecture of the Armored Company Team was analyzed as part of the effort to have a deeper understanding of the composition and functions required of the Armored Company Team.

(1) Capabilities Need

The sole capability need of the Armored Company Team is the need for the U.S. military forces to effectively dominate and succeed in any ground military campaign.

(2) Capabilities

The overarching capability of the Armored Company Team is to enable domination and to triumph in the ground military campaign. To do this, the Armored Company Team must provide a tactical advantage for the U.S. military forces while engaging the enemy through the conduct of various ground military operations in accordance with the Armored Brigade Combat Team Mission Essential Task List (U.S. Army 2012), namely:

1. Conduct Offensive Operations
2. Conduct Defensive Operations
3. Conduct Security Operations
4. Conduct Area Security
5. Conduct Stability Operations
6. Provide Fire Support
7. Conduct Civil Support Operations

The focus of this study will be solely on the Conduct Offensive Operations. The hierarchy of the Armored Company Team Capabilities is illustrated in Figure 5.

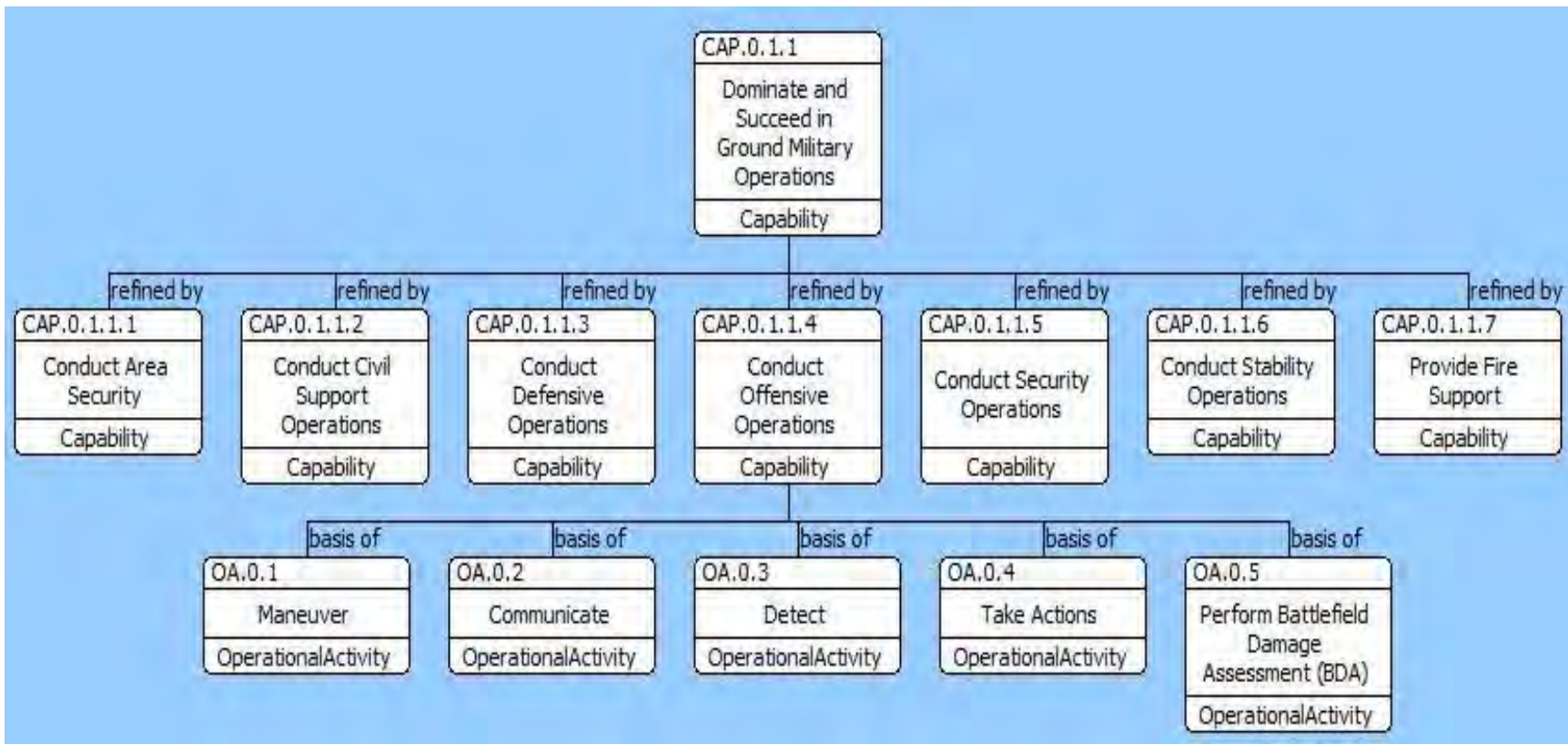

Figure 5. Capabilities of Armored Company Team.

## **1. Operational Architecture**

The operational architecture allows the Armored Company Team to fulfill and accomplish its mission of conducting Offensive Operations. In order to fulfill the conduct of Offensive Operations, the Armored Company Team must be able to perform the Operational Activities illustrated in Figure 6. In compliance with DOD Architecture Framework definition of architecture, the Operational Architecture is illustrated in the form of an Operational Activity Decomposition Tree, also labeled as the Operational View - 5a.

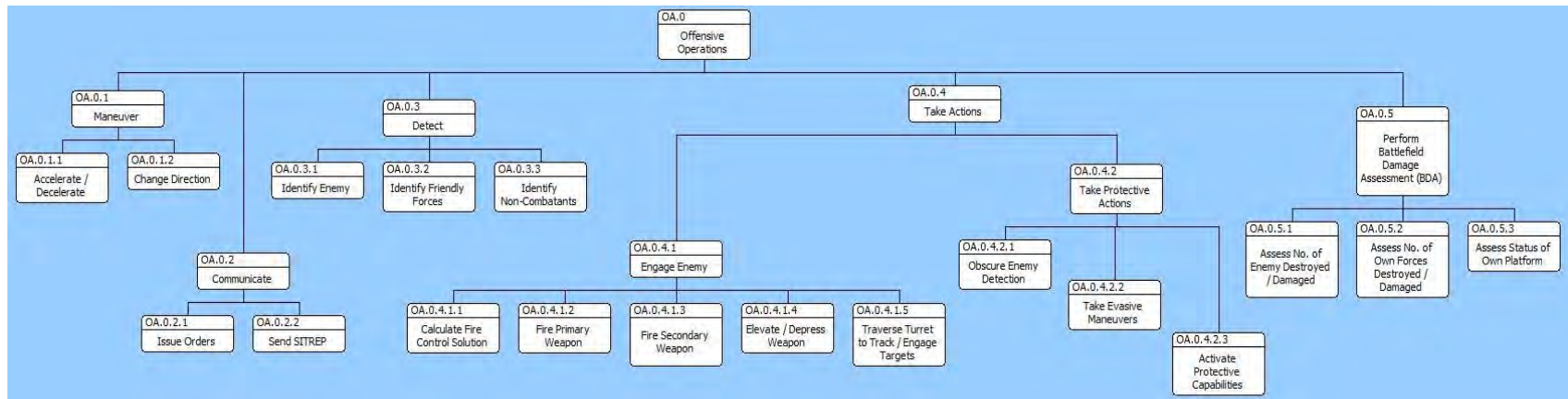

Figure 6. Operational View 5a - Operational Activity decomposition tree of the Armored Company Team.

## **2. Functional Architecture**

In order to fulfill its function of “Performing Offensive Operations,” the Armored Company Team has to carry out various functions that are aggregated in the following manner: To Maneuver, To Communicate, To Sense, To Take Action, and To Perform Battlefield Damage Assessment (BDA). The entire suite of the Armored Company Team functions is decomposed in the following manner, as illustrated in Figure 7.

Functional architecture supports the operational architecture. The functions serve to fulfill the operational activities that are required of the Armored Company Team to accomplish its mission. It is also constructed with the perspective of the survivability of the Armored Company Team in the conduct of offensive operations. The mapping of the functions to the respective operational activities under the operational architecture of the Armored Company Team is shown in Figure 8. Figure 9. Figure 10.

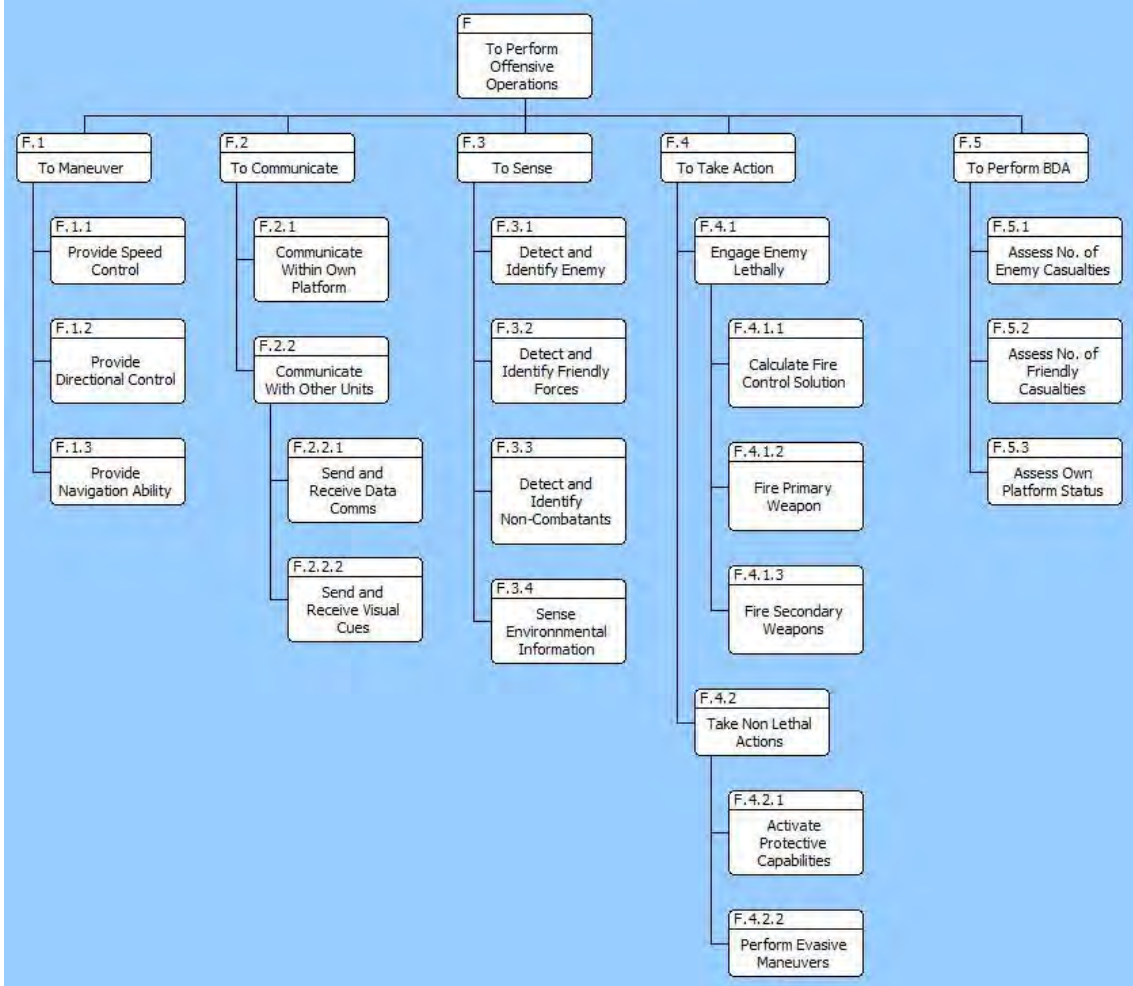

Figure 7. Functional architecture of Armored Company Team.

		OA.0	OA.0.1	OA.0.1.1	OA.0.1.2	OA.0.2	OA.0.2.1	OA.0.2.2	OA.0.3	OA.0.3.1	OA.0.3.2	OA.0.3.3
		Offensive Operations	Maneuver	Accelerate / Decelerate	Change Direction	Communicate	Issue Orders	Send SITREP	Detect	Identify Enemy	Identify Friendly Forces	Identify Non-Combatants
<b>F</b>	<b>To Perform Offensive Operations</b>	✓										
<b>F.1</b>	<b>To Maneuver</b>	✓										
F.1.1	Provide Speed Control		✓	✓								
F.1.2	Provide Directional Control		✓		✓							
F.1.3	Provide Navigation Ability		✓	✓	✓							
<b>F.2</b>	<b>To Communicate</b>	✓				✓						
F.2.1	Communicate within Own Platform					✓	✓	✓		✓	✓	✓
F.2.2	Communicate with Other Units					✓	✓	✓				
<b>F.3</b>	<b>To Sense</b>	✓										
F.3.1	Detect and Identify Enemy								✓	✓		
F.3.2	Detect and Identify Friendly Forces								✓		✓	
F.3.3	Detect and Identify Non-Combatants								✓			✓
F.3.4	Sense Environmental Information								✓			
<b>F.4</b>	<b>To Take Action</b>	✓										
F.4.1	Engage Enemy Lethally									✓	✓	
F.4.1.1	Calculate Fire Control Solution											
F.4.1.2	Fire Primary Weapon											
F.4.1.3	Fire Secondary Weapons											
F.4.2	Take Non Lethal Actions											
F.4.2.1	Activate Protective Capabilities											
F.4.2.2	Perform Evasive Maneuvers											
<b>F.5</b>	<b>To Perform BDA</b>	✓										
F.5.1	Assess No. of Enemy Casualties											
F.5.2	Assess No. of Friendly Casualties											
F.5.3	Assess Own Platform Status											

Figure 8. Mapping of functions of the Armored Company Team to respective Operational Activities – Part 1.

		OA.0.4	OA.0.4.1	OA.0.4.1.1	OA.0.4.1.2	OA.0.4.1.3	OA.0.4.1.4	OA.0.4.1.5	OA.0.4.2	OA.0.4.2.1	OA.0.4.2.2	OA.0.4.2.3
		Take Actions	Engage Enemy	Calculate Fire Control Solution	Fire Primary Weapon	Fire Secondary Weapon	Elevate / Depress Weapon	Traverse Turret to Track / Engage Targets	Take Protective Actions	Obscure Enemy Detection	Evasive Maneuvers	Activate Protective Capabilities
<b>F</b>	<b>To Perform Offensive Operations</b>											
<b>F.1</b>	<b>To Maneuver</b>											
F.1.1	Provide Speed Control										✓	
F.1.2	Provide Directional Control										✓	
F.1.3	Provide Navigation Ability											
<b>F.2</b>	<b>To Communicate</b>											
F.2.1	Communicate within Own Platform		✓	✓	✓	✓	✓	✓	✓		✓	✓
F.2.2	Communicate with Other Units											
<b>F.3</b>	<b>To Sense</b>											
F.3.1	Detect and Identify Enemy			✓								
F.3.2	Detect and Identify Friendly Forces											
F.3.3	Detect and Identify Non-Combatants											
F.3.4	Sense Environmental Information			✓								
<b>F.4</b>	<b>To Take Action</b>											
F.4.1	Engage Enemy Lethally	✓	✓	✓	✓	✓	✓	✓				
F.4.1.1	Calculate Fire Control Solution	✓	✓	✓								
F.4.1.2	Fire Primary Weapon		✓		✓		✓	✓				
F.4.1.3	Fire Secondary Weapons		✓			✓	✓	✓				
F.4.2	Take Non Lethal Actions	✓							✓	✓		✓
F.4.2.1	Activate Protective Capabilities	✓										
F.4.2.2	Perform Evasive Maneuvers	✓									✓	
<b>F.5</b>	<b>To Perform BDA</b>											
F.5.1	Assess No. of Enemy Casualties											
F.5.2	Assess No. of Friendly Casualties											
F.5.3	Assess Own Platform Status											

Figure 9. Mapping of functions of the Armored Company Team to respective Operational Activities – Part 2.

		OA.0.5	OA.0.5.1	OA.0.5.2	OA.0.5.3
		Perform BDA	Assess No. of Enemy Destroyed / Damaged	Assess No. of Own Forces Destroyed / Damaged	Assess Status of Own Platform
<b>F</b>	<b>To Perform Offensive Operations</b>				
<b>F.1</b>	<b>To Maneuver</b>				
F.1.1	Provide Speed Control				
F.1.2	Provide Directional Control				
F.1.3	Provide Navigation Ability				
<b>F.2</b>	<b>To Communicate</b>				
F.2.1	Communicate within Own Platform				
F.2.2	Communicate with Other Units				
<b>F.3</b>	<b>To Sense</b>				
F.3.1	Detect and Identify Enemy		✓		
F.3.2	Detect and Identify Friendly Forces			✓	
F.3.3	Detect and Identify Non-Combatants				
F.3.4	Sense Environmental Information				
<b>F.4</b>	<b>To Take Action</b>				
F.4.1	Engage Enemy Lethally				
F.4.1.1	Calculate Fire Control Solution				
F.4.1.2	Fire Primary Weapon				
F.4.1.3	Fire Secondary Weapons				
F.4.2	Take Non Lethal Actions				
F.4.2.1	Activate Protective Capabilities				
F.4.2.2	Perform Evasive Maneuvers				
<b>F.5</b>	<b>To Perform BDA</b>				
F.5.1	Assess No. of Enemy Casualties	✓	✓		
F.5.2	Assess No. of Friendly Casualties	✓		✓	
F.5.3	Assess Own Platform Status	✓			✓

Figure 10. Mapping of functions of the Armored Company Team to respective Operational Activities – Part 3.

#### **D. MEASURES OF EFFECTIVENESS**

MOEs are defined as the “operational” measures of success that are closely related to the achievement of the mission, or the operational objective being evaluated, in the intended operational environment under specified sets of conditions (i.e., how well the solution achieves the intended purpose) (SE Handbook Working Group 2010).

For the purpose of this research, the following four MOEs that are important and relevant to any military commanders and planners were studied. The importance and justification of the selection of the individual MOEs are elaborated in the following section while Figure 11. illustrates the operational activities from the operational architecture of the Armored Company Team that serve to support the respective MOEs.

OPERATIONAL ACTIVITIES		MOE #1	MOE #2	MOE #3	MOE #4
		Percentage BLUE Casualties	Force Exchange Ratio (FER)	Probability of Completing Mission	Time Steps taken to Complete Mission
<b>OA.0</b>	<b>Offensive Operations</b>				
<b>OA.0.1</b>	<b>Maneuver</b>			✓	✓
OA.0.1.1	Accelerate / Decelerate	✓		✓	✓
OA.0.1.2	Change Direction	✓		✓	✓
<b>OA.0.2</b>	<b>Communicate</b>			✓	✓
OA.0.2.1	Issue Orders			✓	✓
OA.0.2.2	Send SITREP	✓	✓	✓	✓
<b>OA.0.3</b>	<b>Detect</b>	✓	✓	✓	✓
OA.0.3.1	Identify Enemy	✓	✓	✓	✓
OA.0.3.2	Identify Friendly Forces		✓	✓	✓
OA.0.3.3	Identify Non-Combatants		✓		
<b>OA.0.4</b>	<b>Take Actions</b>			✓	
OA.0.4.1	Engage Enemy	✓	✓	✓	
OA.0.4.1.1	Calculate Fire Control Solution	✓	✓	✓	
OA.0.4.1.2	Fire Primary Weapon	✓	✓	✓	
OA.0.4.1.3	Fire Secondary Weapon	✓	✓	✓	
OA.0.4.1.4	Elevate / Depress Weapon	✓	✓	✓	
OA.0.4.1.5	Traverse Turret to Track / Engage Targets	✓	✓	✓	
OA.0.4.2	Take Protective Actions	✓	✓	✓	
OA.0.4.2.1	Obscure Enemy Detection	✓	✓	✓	
OA.0.4.2.2	Evasive Maneuvers	✓	✓	✓	
OA.0.4.2.3	Activate Protective Capabilities	✓	✓	✓	✓
<b>OA.0.5</b>	<b>Perform BDA</b>	✓			
OA.0.5.1	Assess No. of Enemy Destroyed / Damaged		✓		
OA.0.5.2	Assess No. of Own Forces Destroyed / Damaged	✓	✓		
OA.0.5.3	Assess Status of Own Platform	✓			

Figure 11. Mapping of Operational Activities to respective MOEs.

## **1. Percentage BLUE Casualties**

This MOE is important and chosen as the number of casualties sustained is one of the primary concerns of a military commander in a combat operation. The number of casualties incurred directly impacts and affects the amount of combat power that a military commander has to bring to bear on the enemy. In addition, on a more strategic level, the number of casualties sustained has a significant impact on the citizens' positive support of the war effort (Larson 1996).

This MOE is attained by calculating the ratio of the total number of BLUE casualties sustained in the mission over the initial total number of BLUE units that took part in the mission.

$$\text{Percentage BLUE Casualties} = (\text{Number of Blue Casualties} / \text{Total Number of BLUE Units}) \times 100\% \quad (1)$$

This MOE is actually a subset of MOE #2, Force Exchange Ratio. The MOE that addresses Percentage of BLUE Casualties is included as it will provide a quick and unambiguous measurement and indication in the number of casualties that an operation is likely to incur for the BLUE forces. This insight will prove invaluable to military commanders and planners when deciding the size force required.

## **2. Force Exchange Ratio (FER)**

This metric is important as it provides an indication of the effectiveness and lethality of own forces' capability against that of the adversary. In addition, a positive outcome of this MOE (high FER) would aid in reducing the negative impact of the number of casualties sustained by the BLUE forces (Boettcher III and Cobb 2006) and, hence, would aid in garnering positive public perception and support for the combat operations.

This MOE measures the effectiveness of the Armored Company Team in its ability to inflict casualties on the enemy and protecting itself at the same time. It is derived by taking the ration of percentage of RED casualties over the percentage of BLUE Casualties.

$$\text{FER} = \% \text{ Red Casualties} / \% \text{ BLUE Casualties} \quad (2)$$

### **3. Probability of Completing Mission**

The ability to have an indication of the outcome of a combat operation is beneficial. As combat and conflicts are risky and costly affairs, having an indication of the likelihood of success would enable the military commander to make the tough decision of whether to partake in or refrain from fighting (P. L. Sullivan 2008). In addition, it allows the military commander to determine the amount of resources required for the success of the operation.

This MOE provides an indication of the likelihood of the Armored Company Team accomplishing its given mission, hence achieving Mission Success. The conditions required for Mission Success are defined in Chapter V. It is derived by taking the ratio of the number of simulation runs whereby the mission is accomplished over the total number of simulation runs conducted for each individual set of parameters.

$$\text{Probability of Completing Mission} = \text{Number of Runs with Mission Success} / \text{Total Number of Simulation Runs per set of parameters} \quad (3)$$

### **4. Time Steps Taken to Complete Mission**

This metric is important as it provides an indication of the expected length of the conflict. In turn, it allows the military commanders and planners to plan and allocate human and materiel resources that are required to sustain the operation until success is achieved. In addition, increasing the length of the conflict will increase the likelihood of public resentment of the combat operations (L. P. Sullivan 2008). Hence, on a more strategic level, this metric provides the military commanders and planners with a tool to manage and measure public support for the combat operations.

This MOE provides a brief insight into the length of time required by the Armored Company Team to accomplish its mission. It is derived from the direct measurement of the number of time steps taken to accomplish the mission in the simulation model, where each time step is representative of 25 milliseconds in real time.

THIS PAGE INTENTIONALLY LEFT BLANK

### III. SYSTEMS ANALYSIS METHODOLOGY

The systems analysis methodology used for creating the simulation scenario and the analysis of the data for this study are explained in this section. The process begins with the determination of the type of simulations required, followed by choosing the modeling software to create the scenario and farm data. The set of design parameters were determined by means of a design of experiment (DOE) created by statistical software. The results from the simulation were processed and analyzed with statistical software as well.

#### A. TYPES OF MODELS AND SIMULATIONS

A model is defined as a physical, mathematical, or otherwise logical representation of a system, entity, phenomenon, or process. Simulation is defined as a method of implementing a model over time (Coolahan 2003).

The DOD often categorizes models and simulations into four different levels: Engineering, Engagement, Mission and Campaign. The hierarchy of the different types of models is illustrated in the Modeling and Simulation Pyramid in Figure 12.

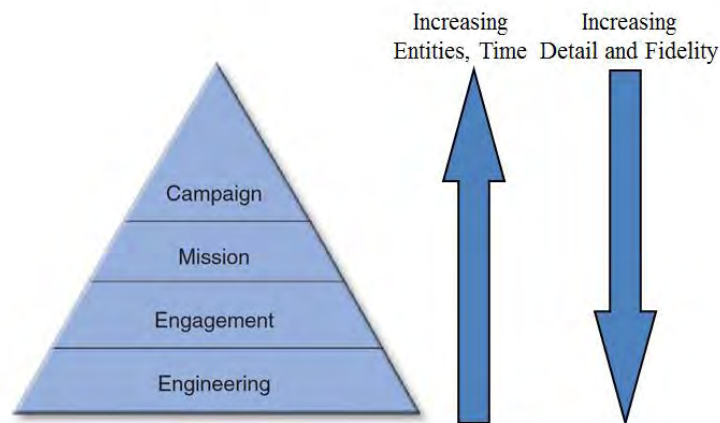

Figure 12. Modeling and simulation pyramid and broad characteristics (from Coolahan 2003).

As the hierarchy increases, the factors of the models, such as time and effects, become more pronounced and accurate at the expense of the detail and fidelity of the model. The different models are typically used by the DOD in the following manner (Coolahan 2003):

(1) Campaign Model

Analysts and experimenters in the DOD typically use the Campaign Model for warfare analysis at a strategic force level.

(2) Mission Model

The Mission Model is used in a similar fashion except in a lower tactical level type of scenario to simulate and model smaller engagements.

(3) Engagement Model

The Engagement Model is used mostly in weapons projects that are being carried out in the DOD.

(4) Engineering Model

Engineering Model is an equation or curve fit based on empirical data that is used to study background phenomenology on military systems by the DOD.

This study gravitated toward the interactions and effects of tactical armor units and enemy forces in a ground mission which is more of a tactical nature. Hence, a “Mission” type of model was deemed to be suitable for use.

**B. MAP AWARE NON-UNIFORM AUTOMATA (MANA)**

MANA was developed by the Defense Technology Agency of the New Zealand Defense Force. MANA is an agent-based, time-stepped, stochastic, map aware modeling tool. The advantages and disadvantages of the modeling software are discussed in the following sections and summarized in Table 2. The following discussion on MANA was referenced from a recent capstone project report on the Distributed Surface Force by the

SEA 20 project team, where the author of this thesis was a co-author (SEA Cohort 20 2014).

Table 2. Summary of advantages and disadvantages of MANA.

ADVANTAGES OF MANA	DISADVANTAGES OF MANA
1. Map awareness	1. Targeting is limited to agent vs. agent
2. In-built degree of randomness in agents	2. General lack of command and control ability
3. Realistic representation of environment	3. Inadequate in modeling physics of projectiles
4. Non-uniform properties of agents	4. Little fidelity in modeling fluctuating environment conditions
5. Areas of interest can be realistically constructed and modeled	5. Does not distinguish point of impact of projectile on agents
6. Intuitive user interface	

### 1. Advantages of MANA

MANA exhibits map awareness, allowing agents in the model to move and react according to specific preset decision processes. Similar to modeling tools where specific waypoint guidance directs individual agents from point to point, MANA has the added benefit of being able to alter the movement of individual squads according to the environment. Real life friction of units in the battle space is simulated through the use of varying levels of randomness in the movement of each unit through its predetermined path space (SEA Cohort 20 2014). This is advantageous as it adds realism to the outcome.

In addition, the designer is able to add realistic landmasses and shallow waters that inhibit travel into the scenario as MANA allows for units to be programmed such that they can only travel over specific environments. Limits can also be set on the

maximum and minimum distances to between units. This enables the designer to evaluate the concept of operations, as well as standard operating procedures that may be employed in the design of the armored vehicles of the future.

Another interesting feature of MANA is the non-uniform aspect of the model. The model allows for each individual unit or squad to be programmed with unique characteristics and limitations. This enables the capabilities and specific features of each unit to be tailored, independently of the group, which is later found to be invaluable in the design of experiments.

Each unit in MANA behaves as a separate and individual complex entity. This means that while each unit will operate according to a specific set of loosely defined guidelines, slight differences in the environment or conditions of two identical units can result in drastically different behavioral actions. Again, this accounts for some friction in the battle space, as well as provides a realistic behavioral outcome for individual units in combat.

Another advantage of using MANA is its ease of use. The user interface is fairly intuitive and does not require advance programming knowledge. Significant resources are available to aid the user in overcoming specific knowledge gaps. Accurate and realistic threat regions can be constructed with relative ease. For example, overlaying global satellite data images allows for terrain manipulation to reflect these images to be completed quickly and intuitively. This is particularly important if the user intends on evaluating specific forces in multiple threat regions.

Finally, the model is time-stepped, making it faster to run multiple scenarios in a given time frame.

## **2. Disadvantages of MANA**

There are some disadvantages to using MANA and a major limitation is agent vs. agent targeting. Offensive units are required to target specific enemy units in order to engage, rather than shooting in the general direction of an incoming group of targets.

Technology advancements have made this a rather significant limitation as advanced weapons systems under consideration utilize individual targeting technologies.

The other major disadvantage to this simulation program is the general lack of a command and control capability. There are no headquarters or command element to control or issue orders to sub-units in the MANA simulation software.

In addition, MANA is inadequate in modeling incoming projectiles. The physics of projectiles, such as trajectory, flight time, etc., are not displayed during engagements. For example, a missile fired by the RED agent hits a BLUE agent instantaneously when conditions are met, without the possibility of interception even if the BLUE agent possesses the capability in actuality. Furthermore, the MANA model has little fidelity in terms of the fluctuating environmental conditions in the operation scenarios. Effects of variation in environmental factors, such as humidity and lighting on mobility and efficiency of the armored vehicles' behaviors cannot be modeled directly and accurately during simulation. In order to mimic environmental influences, proxies such as reduction in speed and weapon hit probabilities have to be used instead, which consequently decreases model fidelity.

Finally, the algorithms in MANA do not discern the location or compartment that is hit when a projectile strikes an agent. This removes the ability to simulate hits on critical components on agents resulting in either catastrophic kills or mission kills.

Hence, after deliberation over the advantages and disadvantages of the MANA modeling software, it was decided that MANA is suitable to be used as the modeling software for this study.

### **C. FACTORS SELECTION**

In order to have a holistic investigation and research into the problem, seven factors that will affect the survivability of an Armored force in urban environment are selected, namely Armor Thickness Percentage, Presence of Active Protection System (APS), Presence of Explosive Reactive Armor (ERA), Mobility Percentage, Signature Management Measures, Presence of Additional Sensor (UAV), and Force Structure.

The selection of the factors aims to address key components of the survivability concept, susceptibility and vulnerability, with respect to the ground armored vehicles. The portion of the survivability concept addressed by each factor is listed. The tracing of the factors to the functional architecture of the Armored Company Team is provided in

**Error! Reference source not found.**

1. Armor Thickness Percentage – Vulnerability
2. Presence of Active Protection System – Susceptibility
3. Presence of Explosive Reactive Armor – Vulnerability
4. Mobility Percentage – Susceptibility
5. Signature Management Measures – Susceptibility
6. Presence of Additional Sensor – Susceptibility
7. Force Structure – Vulnerability and Susceptibility

		FACTORS						
		Armor Thickness %	Presence of Active Protection System	Presence of Explosive Reactive Armor	Mobility %	Signature Management Measures	Presence of Additional Sensors	Force Structure
<b>F</b>	<b>To Perform Offensive Operations</b>							
<b>F.1</b>	<b>To Maneuver</b>				✓			
F.1.1	Provide Speed Control				✓			
F.1.2	Provide Directional Control				✓			
F.1.3	Provide Navigation Ability				✓			
<b>F.2</b>	<b>To Communicate</b>				✓			
F.2.1	Communicate within Own Platform				✓			
F.2.2	Communicate with Other Units				✓			
<b>F.3</b>	<b>To Sense</b>						✓	
F.3.1	Detect and Identify Enemy						✓	
F.3.2	Detect and Identify Friendly Forces						✓	
F.3.3	Detect and Identify Non-Combatants						✓	
F.3.4	Sense Environmental Information						✓	
<b>F.4</b>	<b>To Take Action</b>						✓	
F.4.1	Engage Enemy Lethally						✓	
F.4.1.1	Calculate Fire Control Solution						✓	✓
F.4.1.2	Fire Primary Weapon							✓
F.4.1.3	Fire Secondary Weapons							✓
F.4.2	Take Non Lethal Actions		✓	✓	✓	✓		
F.4.2.1	Activate Protective Capabilities	✓	✓	✓		✓		✓
F.4.2.2	Perform Evasive Maneuvers				✓			✓
<b>F.5</b>	<b>To Perform BDA</b>						✓	
F.5.1	Assess No. of Enemy Casualties						✓	
F.5.2	Assess No. of Friendly Casualties						✓	
F.5.3	Assess Own Platform Status						✓	

Figure 13. Tracing of Design Factors to Functional Architecture of the Armored Company Team.

A summary of the factors and their scope of variations in the simulation, along with the intended effects and the affected portion of survivability concept, are illustrated in **Error! Reference source not found.**

Table 3. Summary of the Seven Factors Variations and the Resultant Effects.

FACTORS	SCOPE OF VARIATION	EFFECTS	PORTION OF SURVIVABILITY CONCEPT ADDRESSED
Passive Armor Thickness Percentage	100% - 140%	Decrease the probability of a hostile projectile penetrating the vehicle	Vulnerability
Presence of Active Protection System (APS)	Present / Absent	50% reduction in Hit Probability of Incoming Projectile	Susceptibility
Presence of Explosive Reactive Armor	Present / Absent	Increasing the number of hits to kill the agent from 1 to 3	Vulnerability
Mobility Percentage	60% to 100%	Varies the speed of the agent from 60% to 100% of original top speed	Susceptibility
Signature Management Measures	Present / Absent	Reduction of IR / Thermal targeting of agent by 30%	Susceptibility
Presence of Additional Sensor (UAV)	Present / Absent	Improve situational awareness of BLUE Forces	Susceptibility
Force Structure	Make up of Armor Company Team from Pure MBT to mix of Bradleys and Strykers	Different ORBAT of the Armor Company Team to investigate the outcomes of the MOEs	Vulnerability and Susceptibility

### 1. Passive Armor Thickness Percentage

The most obvious method to improve the protection of an armored vehicle would be to further pile on more armor to increase the thickness of the armor between the hostile projectile and the occupants and critical components inside the vehicle. The rapid increase in the thickness of armor mounted on vehicles is depicted in Figure 14.

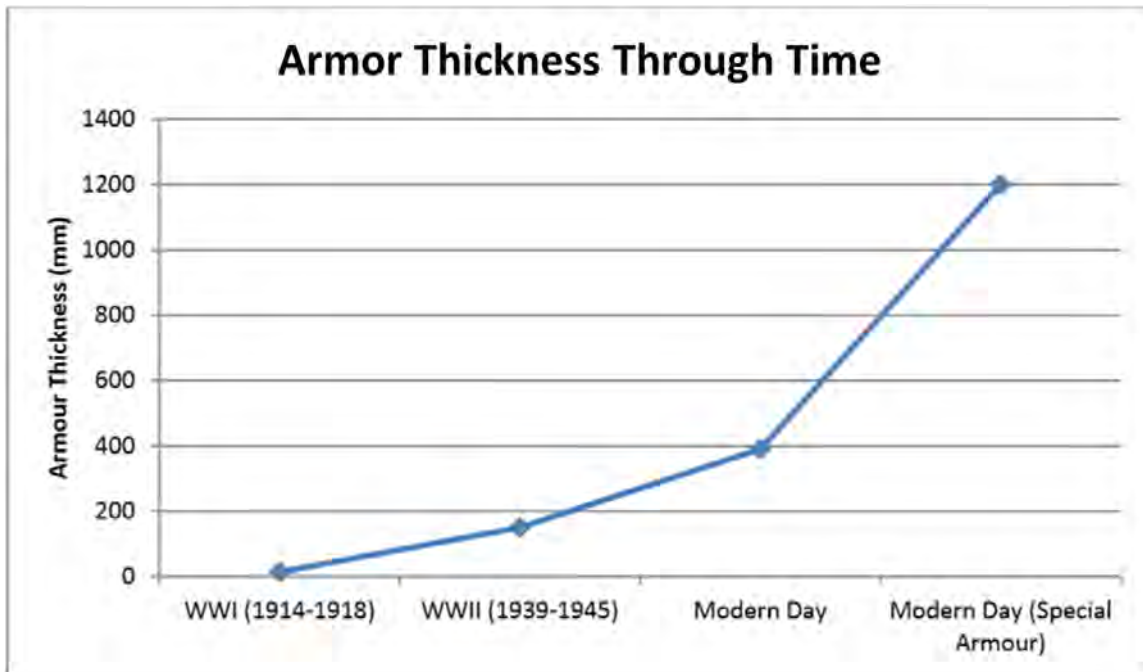

Figure 14. Increase of Armor Thickness on Vehicles since the Conception of Armored Warfare (from Yap 2012).

However, while this may appear to be the obvious method, there is an inflexion point and limitation to the amount of armor that can be mounted on a vehicle due to weight and space constraints on the vehicle. On the other hand, while it is not investigated and based on the author's experience, it would be unwise to reduce the current level of passive armor mounted on armored vehicles. Hence, it is in the interest of this research to vary the armor thickness percentage of the vehicles from the present day value of 100% to a maximum of 140%, which is taken as the physical limit on the amount of armor that can be installed on a vehicle. This is referenced from the author's experience as an armored vehicle operator and background in the defense industry.

## 2. Presence of Active Protection System (APS)

Active Protection System has been employed as a solution to improve the protection of armor vehicles without piling on additional weight in the form of passive armor. It is designed to prevent the incoming hostile projectiles from hitting the vehicle it is intended to protect, as discussed in previous chapters. Active Protection Systems, such

as the Trophy, have proved to be effective in improving vehicle protection as evidenced in the recent Israel – Palestinian conflict (Rogoway 2014) and an illustration of the Trophy system intercepting a projectile is provided in **Error! Reference source not found.**



Figure 15. Trophy APS Intercepting an Incoming Hostile Projectile (from Armada 2013).

Although the effectiveness of the Trophy APS is proven, the Israel Defense Force is currently the only military in the world to widely employ such protection systems. Hence, the agents equipped with APS in the simulation would have an advantage of a 50% hit probability reduction by incoming projectiles.

### 3. Presence of Explosive Reactive Armor (ERA)

ERA has been employed by many militaries around the globe as an asymmetric means of improving the protection of their vehicles without increasing the weight of the vehicle drastically. The ERA prevents the incoming hostile projectile from hitting the vehicle by detonating its explosive when impacted by the projectile, causing the projectile to be destroyed or deviated, hence rendering it ineffective at penetrating the vehicle. **Error! Reference source not found.** illustrates the mounting of ERA on an armored vehicle.



Figure 16. M2 Bradley AFV Mounted with ERA Cassettes (from Osborn 2007).

As the ERA is mounted on vehicles in the form of tiles called “cassette,” it must be noted that once an ERA cassette is hit, it is not regenerative and a hit in the same area would offer no additional protection. However, short of using a tandem shaped-charge projectile, hitting the same spot twice is unlikely under combat conditions. Hence, in this simulation, agents equipped with ERA are given the property of requiring three hits before the hostile projectile is able to penetrate the vehicle.

#### **4. Mobility Percentage**

Mobility of vehicles is an important attribute to its capability. Mobility is also viewed as a form of passive defense as it is increasingly difficult to track, engage, and hit a target moving with increasing velocity (Sher, Refael and Luria 1988). The addition of protection capabilities such as passive armor and ERA cassettes would no doubt increase the weight of the vehicle and correspondingly decrease the mobility of the vehicle (Morris n.d.).

Hence, it is in the interest of this research to vary the mobility of the agents from 100% of original mobility to 60% of their original mobility value. This is referenced from

the author's experience as an armored vehicle operator and background in the defense industry.

## 5. Signature Management Measures

Signature Management Measures is another asymmetric effort in improving the survivability of the vehicle without piling on extra weight and reducing mobility. Signature Management Measures are applied in the form of thermo-variable tiles, as illustrated in **Error! Reference source not found.** which can be mounted on the vehicle to manage and reduce its thermal and infrared red emissions, rendering it more “stealthy” and harder to detect by the adversary (Armada 2013).



Figure 17. Thermo-Variable Tiles Mounted on a Combat Vehicle (CV) – 90 (from Armada 2013).

The effect of reducing the signature emissions of the vehicles mounted with the thermo-variable tiles is that the vehicles are significantly harder to be detected and targeted by the thermal and infrared sighting systems that are employed on the adversary's armored vehicles and anti-tank weapons, as illustrated in Figure 18. This in turn, improves the vehicle's survivability. In the interest of the simulations, agents with

Signature Management Measures employed would have an arbitrary value of 30% reduction in probability of being detected and targeted by adversary agents.



Figure 18. The center picture demonstrates the vast reduction in the vehicle's thermal and infrared red signature with the employment of Signature Management Measures in the form of Thermo-Variable tiles (from Armada 2013).

## 6. Presence of Additional Sensor (UAV)

The additional sensor deployed in the simulation exists in the form of a RAVEN Unmanned Aerial Vehicle (UAV) as shown in Figure 19. The UAV is capable of undertaking Intelligence, Surveillance, and Reconnaissance (ISR) tasks and providing real-time intelligence on enemy dispositions to the BLUE Forces agents (Oestergaard 2014), thus enhancing their situational awareness and enabling the ground platforms to avoid enemy strongholds or capitalize on weakness in enemy's defense.



Figure 19. RQ-11 RAVEN UAV.

It is in the interest of this study to investigate how the presence of increased combat intelligence and improved situational awareness affects survivability of the armored vehicles and the probability of achieving mission success in an urban environment. Hence, the UAV agent is activated and present in certain sets of simulations.

## **7. Force Structure**

For a military outfit to undertake and be successful in a Full Spectrum Operations (FSO), including urban operations, it must be capable of swapping and changing its force structure quickly. The ability to quickly change its force structure is also paramount to maintaining and improving its combat power (United States Army 2008).

It is in the interest of this study to vary the constituent and force structure of the Armored Company Team that is tasked to capture the urban objective in the simulation. The degree of force structure of the Armored Company Team is limited to three armored platoons, ranging from the force structure of having purely MBT platoons (four vehicles each) to having two Bradley AFV platoons (three vehicles each) and 1 Stryker ICV platoon (three vehicles each). Having a heavier force structure for an Armored Company Team would improve its vulnerability and at the same time, with better firepower, it can take out enemy units more effectively and hence reduce its probability of being targeted by the enemy.

Table 4. illustrates the eight different sets of force structures used in the simulation, along with their assigned value for the conduct of design of experiment and the number of vehicles in the Armored Company Team.

Force Structure (Number of Platoons)	Value for DOE	Number of Vehicles
3 M1A2 MBT	8	12
2 M1A2 MBT + 1 Bradley AFV	7	11
2 M1A2 MBT + 1 Stryker ICV	6	11
1 M1A2 MBT + 2 Bradley AFV	5	10
3 Bradley AFV	4	9
1 M1A2 MBT + 1 Bradley AFV + 1 Stryker ICV	3	10
1 M1A2 MBT + 2 Stryker ICV	2	10
2 Bradley AFV + 1 Stryker ICV	1	9

Table 4. Force Structure of the Armored Company Team and its associated number of vehicles.

#### D. DESIGN OF EXPERIMENTS

A DOE is required for the conduct of the study. DOE allows the logical, systematic, and intelligent conduct of simulations that involves numerous factors and design points. It allows the study to fully define and explore the design space, hence allowing the simulation to have the best chance of generating significant results that address the research questions.

A robust DOE can be accomplished by using factorial designs. Factorial designs allow the analysis of more than one factor at a time. Through the analysis, the important factors and their interactions can be identified and singled out for further study and analysis (Sanchez 2005).

The full factorial design is a  $2^k$  factorial design, where  $k$  is the number of factors. Each factor has only two levels of inputs, namely High and Low. This basic DOE approach allows quick and thorough examination and coverage of the extreme and boundaries of the entire design space. Hence, a full factorial design of seven factors would entail 128 sets of design points ( $2^7 = 128$ ). The DOE software, MINITAB, was used to generate the 128 sets of design points that made up the initial set of simulations for this study.

Once the important factors were identified using regression analysis, the factors were decomposed into finer levels of inputs to reveal more insights and complexities of

the entire design space. The downside to this is that a massively large number of design points will be generated and require substantial effort and time for a complete execution of the simulations.

To circumvent this, the space filling property of the Nearly Orthogonal Latin Hypercube (NOLH) was being utilized to sieve out the more important and significant design points. This allowed more factors to be included within a fixed sample size with good space-filling properties. Good space-filling DOE is defined as one where the design points are scattered throughout the experimental region with minimal unsampled region (Cioppa and Lucas 2007). As a result, 129 sets of design points were constructed for the refined set of simulations. In addition, the space filling properties of the entire design of experiment is illustrated in Figure 20.

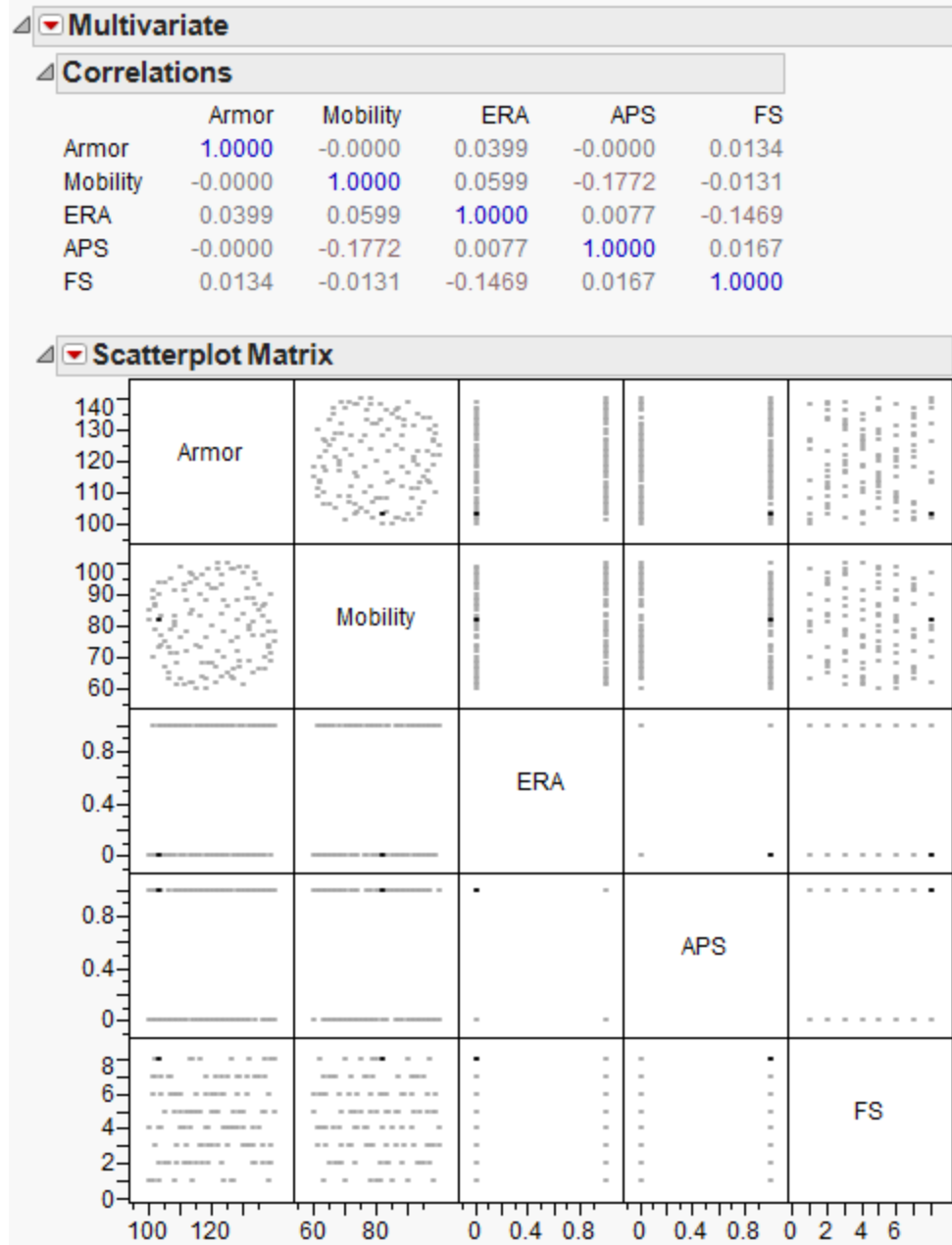

Figure 20. NOLH for the final simulation runs.

As observed in Figure 20. generated using the statistical software JMP Pro 10, the set of design points is well spread out and fills the design space adequately. While the space filling outcome for the design factors of Explosive Reactive Armor (ERA) and Active Protection System (APS) may appear vacant, it must be noted that they are two-state factors, which means the simulation is only affected by their presence or absence.

Hence, the design space involving ERA and APS was actually well sampled in the two extremes by the NOLH.

#### **E. DATA FARMING AND ANALYSIS**

The data obtained from MANA was analyzed using statistical software, JMP Pro 10. The motivations for using this particular software were that this software is appropriate for the study as it allows the thorough regression analysis of the large amount of simulation results. In addition, the software generates good and intuitive graphics for easy comprehension.

The data was analyzed using regression analysis (Princeton University 2007) to identify the main effects and their important interactions in determining the outcomes of the four important MOEs, which essentially is the gist of the research, which will be explained in later chapters. The results from the analysis provide insights and serve as a guide to military planners and commanders on the employment of their military assets, in addition to answering the research questions listed in Chapter I that spurred this study.

## **IV. COMBAT OPERATIONS**

In any military campaign, the armored forces would be expected to operate in several tactical scenarios such as taking part in offensive or defense operations.

### **A. OFFENSIVE OPERATIONS**

Offensive operations are the decisive form of battle. The primary purpose of the offense is to defeat, destroy, or neutralize an enemy force. A commander may also take offensive actions to deceive or divert the enemy, deprive him of resources or decisive terrain, develop intelligence, or hold an enemy in position. Armor forces are especially well suited to perform this operation (United States Army 2013).

### **B. MISSION SETS OF OFFENSIVE OPERATIONS**

Armor forces are especially well suited and adaptive in performing the high tempo and high mobility missions or tasks that are typical of offensive operations. The sets of missions that are associated with the conduct of offensive operations are the following (United States Army 2013).

1. Attack
2. Frontal Attack
3. Movement to Contact
4. Penetration
5. Envelopment
6. Infiltration
7. Appropriate March Techniques

This paper explores and researches the operation for an Armored Company Team to attack and capture an urban objective, which involves all the listed mission sets. These are related to the operational activities for offensive operations described in Chapter II as the attack and capture of an urban objective is indeed an offensive operation.

## **C. URBAN ENVIRONMENT**

An urban area is defined as the area of a city. Most of the urban area's populace has nonagricultural jobs. Urban areas are highly developed, with a high density of man-made structures such as buildings, roads, bridges, and railways (GlobalSecurity.org 2006).

### **(1) Buildings and Infrastructures**

Operating in an urban environment poses several considerations. The most obvious is the presence of a large number of densely situated buildings. The buildings provide cover and concealment and, at the same time, severely limit the field of observations and fire. The presence of the buildings also imposes restrictions on the movement of troops and vehicles. In addition, the buildings provide a third dimension of combat by allowing engagements to be initiated and take place from rooftops.

### **(2) Roads and Streets**

The presence of roads and streets is another characteristic of the urban environment. They provide avenues of approach and facilitate the movement of vehicles. However, the roads and streets often are canalized by the presence of buildings and the urban terrain offers little mounted maneuverability off the roads and streets.

### **(3) Airspace**

The airspace over the urban terrain offers the unique ability of rapid deployment of troops and forces. The air assets have more freedom of movement, as compared to ground forces, as they are less affected by the physical constraints posed by the buildings and infrastructures.

### **(4) Civilians**

The unavoidable consequence of operating in an urban environment is the close proximity of a large number of civilian non-combatants. This poses significant problems and restrictions to the ethical military commander. Issues of target legitimacy remain

debatable. In the recent Israel and Hamas conflict in the Gaza strip, it is notable that a significant number of civilians became casualties of war.

(5) Impedance for Armor Forces

Armor forces were designed to operate in high tempo and mobility operations in an open terrain. Their characteristic heavy firepower, mobility, and longer range of observations and engagement are severely limited in the urban environment where these attributes are significantly degraded. The restrictions for effective armor operations in urban terrain would spell impending doom to the crew of an armored vehicle as it becomes trapped and falls victim in the urban terrain (Urban Warfare Special 2006).

## **D. GROUND PLATFORMS OVERVIEW**

The ground military units that are used in the research and simulation are discussed in the following section.

### **1. BLUE Forces**

The ground combat platforms for the BLUE forces are classified as Main Battle Tanks (MBT), Armored Fighting Vehicle (AFV), and Infantry Carrying Vehicles (ICVs). While it is difficult to get an accurate value for the armor thickness of each vehicle type, the main battle tanks have the thickest armor, followed by the armored fighting vehicles and the infantry carrying vehicle. The openly accepted value of the armor thickness of the hulls of the various types of armored vehicles is stated in the following sections.

(1) Main Battle Tanks (MBT)

The MBT used in this simulation is the M1A2 Abrams Main Battle Tank. The MBT boasts a 120mm Main Gun that fires the Armor Piercing Fin Stabilized Discarding Sabot-Tracer (APFSDS-T) and High Explosive Anti-Tank (HEAT) ammunition. In addition, the secondary armament of the M1A2 MBT includes a .50 caliber Machine Gun, a co-axially mounted 7.62mm Machine Gun, and a 7.62mm Loader's Machine Gun. The MBT has the heaviest armor complement of all ground platforms and the armor thickness of its hull is equivalent to 960mm of rolled homogenous armor (RHA). The

vehicle is fully tracked and is operated by a crew of four (Kable Intelligence Limited 2014). A pictorial illustration of the M1A2 MBT is shown in Figure 21.



Figure 21. M1A2 Main Battle Tank (from Yap 2012).

## (2) Armored Fighting Vehicle (AFV)

The Armored Fighting Vehicle used in this simulation is the M2 Bradley. The vehicle boasts a 25mm cannon with a complement of the Tube Launched, Optical Tracked and Wire Guided (TOW) Anti-Tank Guided Missile (ATGM). It has a lighter armor outfit as compared to the M1A2 MBT and the armor thickness of its hull is equivalent to 500mm of RHA. The M2 Bradley is operated by a crew of three and has the capacity to carry six fully equipped infantry soldiers (Army Technology 2014). A pictorial illustration of the M2 Bradley AFV is shown in Figure 22.



Figure 22. M2 Bradley AFV (from Yap 2012).

***b. Infantry Carrying Vehicles (ICV)***

The Stryker is used as the Infantry Carrying Vehicle in the simulation. Its armament consists of a .50 caliber machine gun and a 40mm Automatic Grenade Launcher. The vehicle has the lightest armor in the suite of ground platforms used in the simulation and the armor thickness of its hull is equivalent to 250mm of RHA. The Stryker is wheeled and boasts the capability of operating quietly in an urban environment as compared to tracked vehicles. The Stryker is also capable of carrying a squad of fully equipped infantry soldiers (Army Technology 2013). A pictorial illustration of the Stryker ICV is shown in Figure 23.



Figure 23. Stryker Infantry Carrying Vehicle (from Army Technology 2013).

## 2. Threats

Ground military platforms are subjected to a wide spectrum of threats from all dimensions. The main threats present themselves in the form of adversary Main Battle Tanks and Armored Vehicles, Anti-Tank Weapons, Improvised Explosive Devices, and mines. This list is by no means exhaustive and the following section discusses the ground threats faced by the Armored Company Team.

### (1) Adversary Main Battle Tanks and Armored Vehicles

The best way to defeat an armored vehicle is to use another armored vehicle of similar or heavier class. The enemy armored vehicles used in this simulation are the T-90 MBT and the BMP-2 AFV. These adversary armored vehicles have similar characteristics, protection, mobility, and firepower as their counterparts in the BLUE forces.

### (2) Anti-Tank Weapons

The Anti-Tank Weapons used in the research are the Rocket-Propelled Grenades (RPG) and the Anti-Tank Guided Missile (ATGM) such as the Milan. The RPGs are shoulder-launched weapons with a High Explosive Shaped Charge to defeat the armor of

the ground platforms. It has a relatively short range and inferior accuracy. The RPG used in the simulation is the RGP-29 (Defense Update 2006).

For ATGMs, the damage mechanism is through the means of a high-explosive warhead contained in the missile. The ATGM has a longer range as compared to the RPG and a higher accuracy due to the presence of visual or imaging infrared seekers installed in the missile. The ATGM is man portable and can also be installed on vehicles (abcNEWS 2014).

### (3) Mines and Improvised Explosive Devices (IED)

Anti-Tank Mines feature high-explosive warheads. They are designed to be deployed on the ground and where the pressure or vibrations from an armored vehicle triggers its detonation when the vehicle rolls over the mines unknowingly. The mines are designed to attack the weakest part of the armor, which is found at the under belly of the vehicle (Bonsor 2012).

Improvised Explosive Devices (IEDs), as the name suggests, are made of haphazard materials and are essentially homemade bombs. Their damage mechanism ranges from high explosives to shaped charges and explosively formed penetrators. They function similarly to the anti-tank mines, relying on concealment and surprise to prey on the unsuspecting crews of armored vehicles (National Academies 2012).

### (4) Technicals

Technicals are haphazardly modified trucks or automobiles that are outfitted with weaponry ranging from the .50 caliber machine gun, RPG toting insurgents, or the even more deadly ATGMs. They have little or no armor protection and rely on their high mobility and ambush tactics to survive and destroy their targets (Somaiya 2010).

### (5) Small Arms

Although most of the heavy armored vehicles such as the MBTs are impervious to small arms fire, AFVs and IFVs with their relatively lighter armor are still susceptible to small arms such as the hardened steel core Armor-Piercing rounds from a 50 caliber

machine gun, which is commonly found on other armored vehicles or mounted on the back of a technical (Federation of American Scientist 1999).

## **E. PROTECTION**

One of the functions of the armored vehicle is to survive in order to carry out its orders and accomplish its mission. To achieve that, it must have a credible and effective protection system installed. In general, the types of protection systems found on armored vehicles can be broadly classified into Passive and Active Protection Systems.

### **1. Passive Protection**

Passive protection exists in the form of static armor which is a protective device that protects against kinetic and chemical energy ammunition by absorbing the energy of the projectile. It is the most prevalent and most basic form of protection that is found on armored vehicles (Kwok and Lim 2013). Common types of Passive Armor are made of armor steel materials or composite materials such as:

1. Rolled Homogeneous Armor (RHA)
2. High Hardness Steel (HHS)
3. Laminate Armor
4. Composite Armor
5. Slat Armor

### **2. Active Protection**

Active protection is defined as a system that is employed to prevent anti-armor line of sight weapons from acquiring or destroying a target. Active protection is often classified into Hard Kill, where it destroys the incoming threat decisively, or Soft Kill, where it prevents the threat from hitting or destroying the target although touted to be more effective than the passive armor, active protection is largely limited to its inherent high cost which prevents its prevalent employment. Systems such as Explosive Reactive Armor, Trophy, Iron Fist, and Iron Curtain are common APS (Armada 2013).

*a. Hard Kill Active Protection System*

The Hard Kill APS employs the concept of destroying the incoming projectile before it hits the armored vehicle. It functions by having a sensor which detects the incoming projectile and by making split second calculations; the APS launches a projectile of its own to intercept the hostile projectile and destroy it, thereby preventing the armored vehicle from being hit. In the recent Israel and Hamas conflict in the Gaza strip, there were confirmations and reports of an APS, Trophy, mounted on the Israel Merkava MBT intercepting an RPG that was fired at it. This validates the concept and effectiveness of the APS (Armada 2013). Figure 24. illustrates the chronology of events of a generic active protection system and Figure 25. illustrates the mounting of an APS on a MBT.

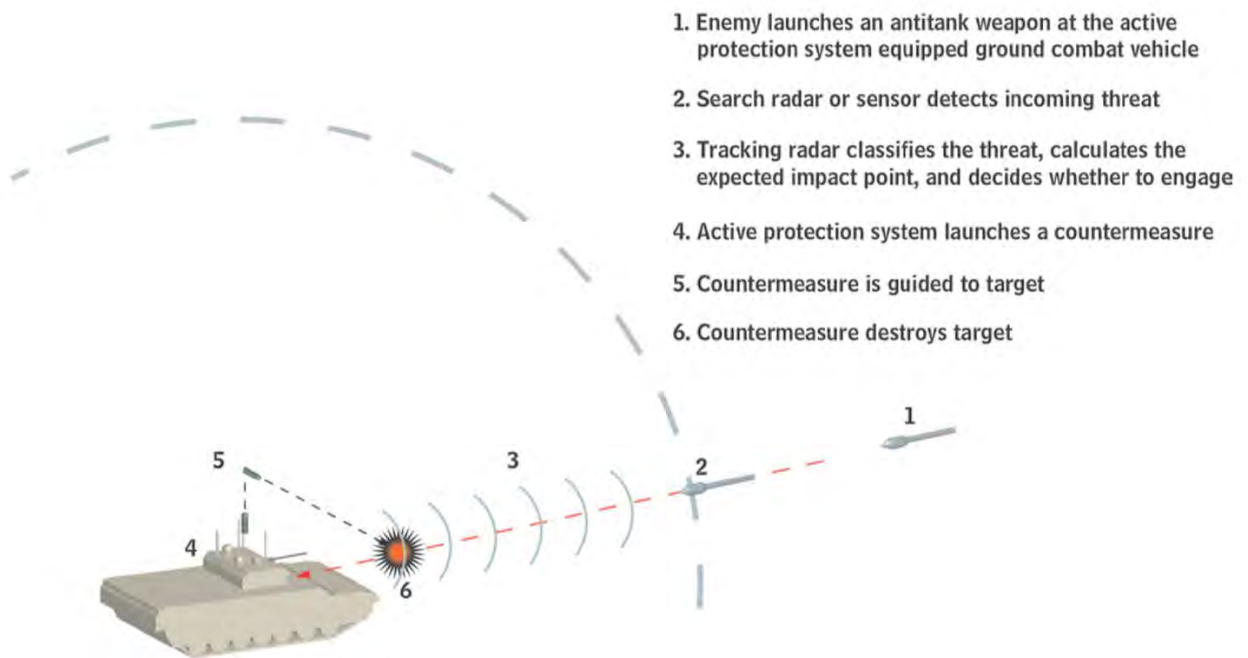

Figure 24. Chronology of events for the functioning of a generic Hard-Kill Active Protection System (from Treml 2013).



Figure 25. APS (Trophy) mounted on a Merkava Mk 3 of the Israel Defense Forces (from Armada 2013).

***b. Explosive Reactive Armor (ERA)***

The ERA consists of an explosive liner that is placed in between two metal plates in the form of a “cassette.” The ERA is typically mounted on the hull and turret of the armor vehicles as that is the area that is most likely to be subjected to hits by hostile projectiles. The explosive liner is detonated upon impact by an incoming projectile, creating energy that defeats or deflects the hostile projectile, thereby reducing its effectiveness and protecting the armored vehicle (Osborn 2007).

There are other APS available such as the counter measures for electronic warfare. However, they were not included in the simulation and remain a source for future work in this area of research.

**F. SENSORS**

To sense and detect enemy and friendly forces is an essential function of any armored vehicle. The sensors are broadly classified into Armored Vehicle Sensors and the Unmanned Aerial Vehicle (UAV) in this study.

(1) Armored Vehicle Sensors

An armored vehicle is typically equipped with an optical primary sensor that is being used to obtain its target and for aiming purposes when operating the main weapon system. The primary sensor is augmented by a thermal sensor that detects and tracks targets by the temperature difference with the ambient environment. This secondary sensor often has a lesser degree of magnification but a wider field of view as compared to the primary optical sensor (Foo 2014).

(2) Unmanned Aerial Vehicle (UAV)

The UAV functions as an additional sensor to the armored vehicle. It is often deployed in orbit above the area of operations and transmits information of enemy activities and deployments back to the friendly forces to enhance their situational awareness and decision making process. This is being done using electro-optics and infrared red sensors.

**G. FORCE STRUCTURE OF ARMORED COMPANY TEAM**

Military task forces are inherently made up of smaller, independent tactical units. Military commanders on the ground often have the prerogative to alter an Armored Company Team's organic and assigned assets to provide better resources to their subordinate commanders for the mission at hand. The alteration of the Armored Company Team's organization is also often precipitated by the need for better command and control based on the situation (United States Army 2005).

For the purpose of this research, the Armored Company Team has the option of eight different force structure combinations of varying strength and firepower, which will be further elaborated in Chapter V.

THIS PAGE INTENTIONALLY LEFT BLANK

## **V. SCENARIO MODELING**

The motivation, considerations, and constraints in developing the operational scenario are discussed in this chapter.

### **A. HYPOTHETICAL OPERATIONAL SCENARIO**

The scenario used in the modeling portion of the research is that of an operation undertaken by an Armored Combat Team (BLUE Forces), with variation in force structure and consisting of three armored platoons, to capture an urban terrain objective, OBJ MEGAN. The scenario map used in the simulation measures approximately 10 miles by 7 miles. The attackers (BLUE Forces), aided with an UAV, start the operation by attacking from the east. Their task of capturing OBJ MEGAN will be considered successful upon capturing one of the two land links across the river at the western edge of the objective or with the destruction of the defenders' forces. The BLUE forces faced a numerically superior enemy force (RED Forces), consisting a mixture of MBTs, AFVs, troops with anti-tank weapons, technical, mines, and IEDs. The RED Forces were dug in and defending the urban objective as illustrated in Figure 26.

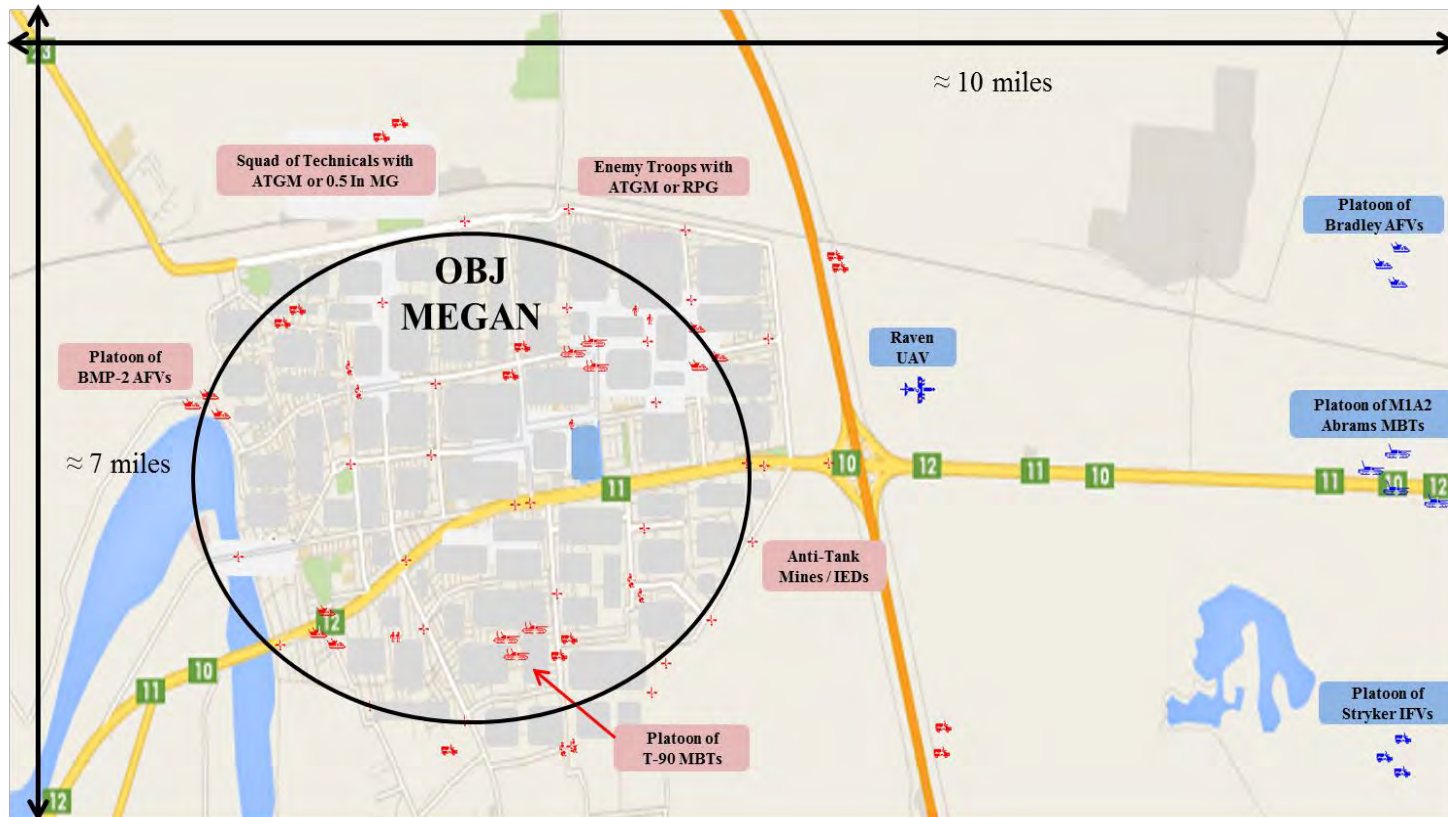

Figure 26. Initial layout of BLUE and RED Forces for the simulation of an attack operation by an Armor Combat Team to capture an urban objective using MANA.

## B. REAL LIFE REFERENCE

An example of the modern military’s violent and successful assault on and capture of an urban terrain using purely armored forces is documented in the book titled *Thunder Run: The Armored Strike to Capture Baghdad*. The city of Baghdad was taken by a surprise assault by the Second Brigade of the Third Infantry Division (Mechanized) using three battalions of a mixture of M1A2 MBTs and Bradley AFVs (Zucchini 2004).

In addition, the recent Israel-Palestinian conflict has provided many references and instances that depict and reinforce the notion of frequent fighting in an urban environment (Associated Press 2014). These two examples laid the foundation and motivation for the construction of the modeling scenario for the research.

## C. OPERATIONAL ORDERS

A short snippet of the typical operational orders issued to an Armored Combat Team Commander for assault operations is included to provide a better understanding of the modeling scenario. An operation overlay is provided in Figure 27. to facilitate the understanding of the scenario. **Error! Reference source not found.** provides the meanings of the military symbols used in the operations overlay.

Table 5. Military symbols and their meanings.

BLUE FORCES		RED FORCES		MISC	
ICONS	MEANING	ICONS	MEANING	ICONS	MEANING
	Platoon of M1A2 Abrams MBT		T-90 MBT Tank Team on Patrol		Task and Purpose of Units
	Platoon of M2 Bradley AFV		BMP-2 on Patrol		Key Terrain for BLUE Forces
	Platoon of Stryker ICV		Technicals with ATGM or 50 cal MG on Patrol		
	Main Effort		Troops with ATGM		
	Supporting Effort		Troops with RPG		
			Enemy Defense Position		

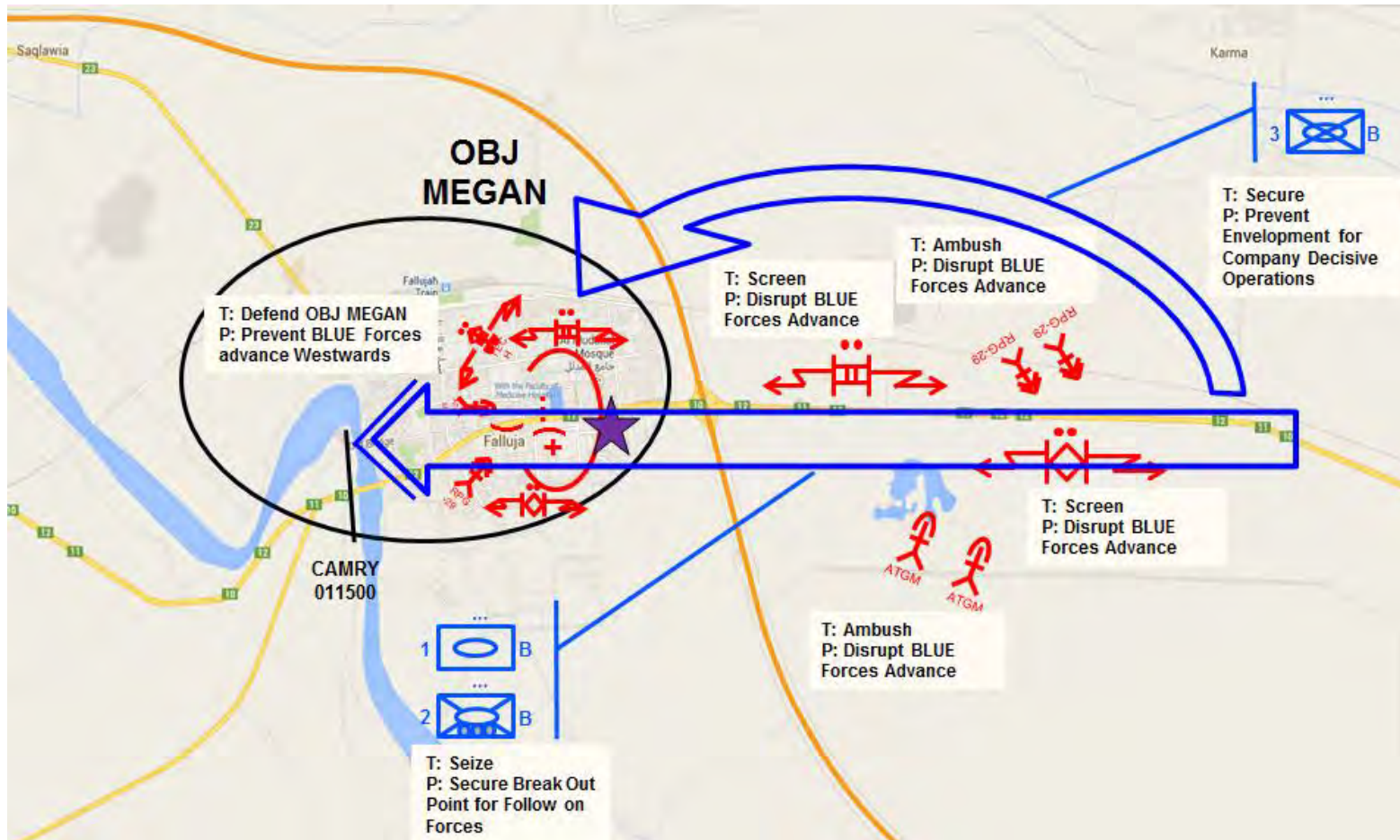

Figure 27. Operations overlay for the scenario.

## **1. Terrain**

### **(1) Obstacles**

The most significant natural obstacle is the river at the western edge of the Area of Operations (AO). There are several water bodies that are dispersed throughout the AO. There are no significant man made obstacles in the AO. However, protective obstacles in the form of concertina wires around the buildings in the objective can be expected. In addition, IEDs and undetected mines can be expected in the AO as well.

### **(2) Avenue**

In general, the AO can be easily approached by armored forces as it is comprised mainly of desert terrain. There are two main paved roads in the AO – one running from the north to south while the other runs from the east to the west across the AO. The east to west paved road is identified as the main avenue of approach into the urban objective. The intersection of the two paved roads denotes the eastern most boundary of the objective.

### **(3) Key Terrain**

The Key Terrain is identified as the two land link or bridges across the river at the western edge of the objective. This is because the land links facilitate the reinforcement, resupply and withdrawal of the defenders of the objective.

### **(4) Observations**

The general terrain of the AO offers good observation due to its relatively flat gradient. However, once inside the urban environment, fields of observations and fires will be severely restricted by the presence of a large number of buildings and structures.

### **(5) Cover and Concealment**

The general terrain of the AO offers very poor cover and concealment, due to its open dessert like terrain. However, cover and concealment drastically improves once inside the urban terrain due to the presence of large number of buildings and structures that offer good cover and concealment.

## **2. Enemy Situation**

### **(1) General Enemy Situation**

In the past 120 hours, RED forces have dug in and fortified OBJ MEGAN in an effort to halt the advance of BLUE forces westward.

### **(2) Composition and Strength**

The enemy is comprised of a Battalion that is made up of T-90 MBTs and BMP-2 AFVs, along with an unidentified number of anti-tank weapons from dismounted troops and technicals.

The enemy is organized into a screening force and the main defense force. The screening force is expected to be made up of technicals mounted with anti-tank weapons that conduct patrols on the eastern and northern edge of the objective.

The main bulk of the RED forces make up the main defense force, consisting of up to two platoons of T-90 MBTs and three platoons BMP-2 AFVs, along with dismounted troops and technicals with anti-tank weapons. The RED forces are expected to deploy mines and IEDs to disrupt the BLUE forces advance.

### **(3) End State**

The RED forces are envisioned that at the end state of the conflict to be achieving victory, with the repulsion and destruction of the advancing BLUE forces, with the objective being intact to the RED force.

## **3. Friendly Situation**

### **(1) Brigade Commander's Intent**

The Brigade Commander's Intent is to secure at least one break out point in the AO to facilitate the passage of follow-on forces from the division.

(2) Battalion Commander's Intent

The Battalion Commander's Intent is to capture the urban objective to the east of the river in the AO in order to secure a breakout point for the passage of follow-on forces no later than (NLT) 011500 hours (Day 01 and Time 1500).

**4. Mission**

B/1-2 is to capture OBJ MEGAN NLT 011500 hours in order to facilitate the passage of follow-on forces.

**5. Execution**

(1) Commander's Intent

The Company Commander's intent is to rapidly capture OBJ MEGAN and the two land links across the river to the west of the objective, while inflicting maximum casualties to the RED forces at the same time.

(2) Operation's Purpose

This will allow the rapid collapse of the RED force's defense in OBJ MEGAN and facilitate the capture of OBJ MEGAN to allow the passage of follow on forces.

(3) Concept of Operation

This operation is achieved by an envelopment assault on OBJ MEGAN. This operation is supported by an UAV to provide real-time intelligence and information.

(4) End state

End states of the operations are:

(5) Own Forces

BLUE Forces to remain combat effective (less than one-third of its forces attrited) at the end of the operation.

(6) Enemy

Maximum RED force casualties inflicted.

(7) Terrain

One of the two land links across the river secured by the BLUE Force.

**D. CONDITIONS FOR MISSION SUCCESS**

All military operations will have a goal or objective in mind as mandated in the Principles of War (United States Army 2008). The conditions for military success must be clearly defined and attainable, and in this instance, the objectives are two-fold and achieving either will constitute mission success.

**1. Destruction of 50% of Enemy (RED) Forces**

The destruction of half of the defending enemy forces will conclude the capture of the urban objective. Being rendered combat ineffective and unable to hold and defend the objective effectively, the defense of the urban terrain by the RED forces will be untenable and the BLUE forces will have achieved its mission of capturing the urban objective.

**2. Isolation of Enemy Forces by Capturing the Two Bridges across the River**









From the perspective of the defender (RED forces), the main consideration of defensive operations, other than repelling the attackers would be to prevent being cut off or isolated by the attackers (BLUE forces). Isolation can rapidly cause a drastic drop in morale and military options for soldiers and commanders and precipitate the downfall of the entire defensive operation (United States Army 2008).

Hence, in this modeled scenario, the arrival of the BLUE forces' agents at the two bridges spanning the river in the western portion of the objective and capturing them would effectively isolate the RED forces in defense. This would render their defense untenable and facilitate an early downfall of their defensive positions as the RED forces have no choice but to give up their defensive positions and fall back.

## E. AGENTS SUMMARY

Table 6. summarizes the number and type of agents (both BLUE and RED forces) that are used in the simulations. The parameters of all the agent attributes used in the simulation are illustrated in Appendix A.

Table 6. Summary of agents used in the simulations.

BLUE FORCES			RED FORCES		
ICONS	TYPE	NUMBER	ICONS	TYPE	NUMBER
	M1A2 Abrams MBT	12		T-90 MBT	6
	M2 Bradley AFV	9		BMP-2	9
	Stryker ICV	9		Technicals with ATGM or 0.5 In MG	14
	Raven UAV	1		Troops with ATGM or RPG	12
				Anti-Tank Mines / IED	30
<b>Total Number:</b>		<b>31</b>	<b>Total Number:</b>		<b>71</b>

It must be noted that the table tabulates the number of agents that are being used in the simulations. The number is accurate for the RED forces for each different set of simulation as the strength of the RED forces is not one of the factors being studied and hence their numbers are not varied.

However, for the BLUE forces, the number of agents varies from nine to 12. A platoon of M1A2 MBTs consists of four vehicles while a Bradley or Stryker platoon consists of three vehicles each. Hence, depending on the force structure of the three platoons that constitute the Armored Combat Team, the number of BLUE ground agents can range from 12 agents, when task organized as a pure MBT Combat Team, or nine agents when task organized otherwise. This will be further elaborated in Chapter VI.

THIS PAGE INTENTIONALLY LEFT BLANK

## **VI. RESULTS ANALYSIS**

The purpose of the simulations was to determine the design factors of an Armored Company Team that are significant in determining the outcome of the four previously discussed MOEs. As a recap, the seven design factors are Armor Thickness (%), Presence of Active Protection System, Presence of Explosive Reactive Armor, Mobility (%), Presence of Signature Management Measures, Presence of Additional Sensors, and Force Structure. In addition, the four MOEs are Percentage of BLUE Casualties, Force Exchange Ratio, Probability of Completing Mission, and Time Steps taken to Complete Mission.

### **A. INDICATORS OF SIGNIFICANCE OF RESULTS**

As mentioned in earlier chapters, the analysis of the simulation results was performed with the statistical software, JMP Pro 10. JMP Pro 10 takes all the factors used in the simulation and the associated results into account when performing regression analysis and attempts to fit a regression line for all the data points by generating a prediction of the results based on the interactions of the factors. The fidelity of the regression model, magnitude of effects of each factor, and their significance to the result of the MOES were then presented in the form of graphs and tables. Figure 28. illustrates and explains the generic output of JMP Pro 10 when performing the analysis of the results derived from the simulations.

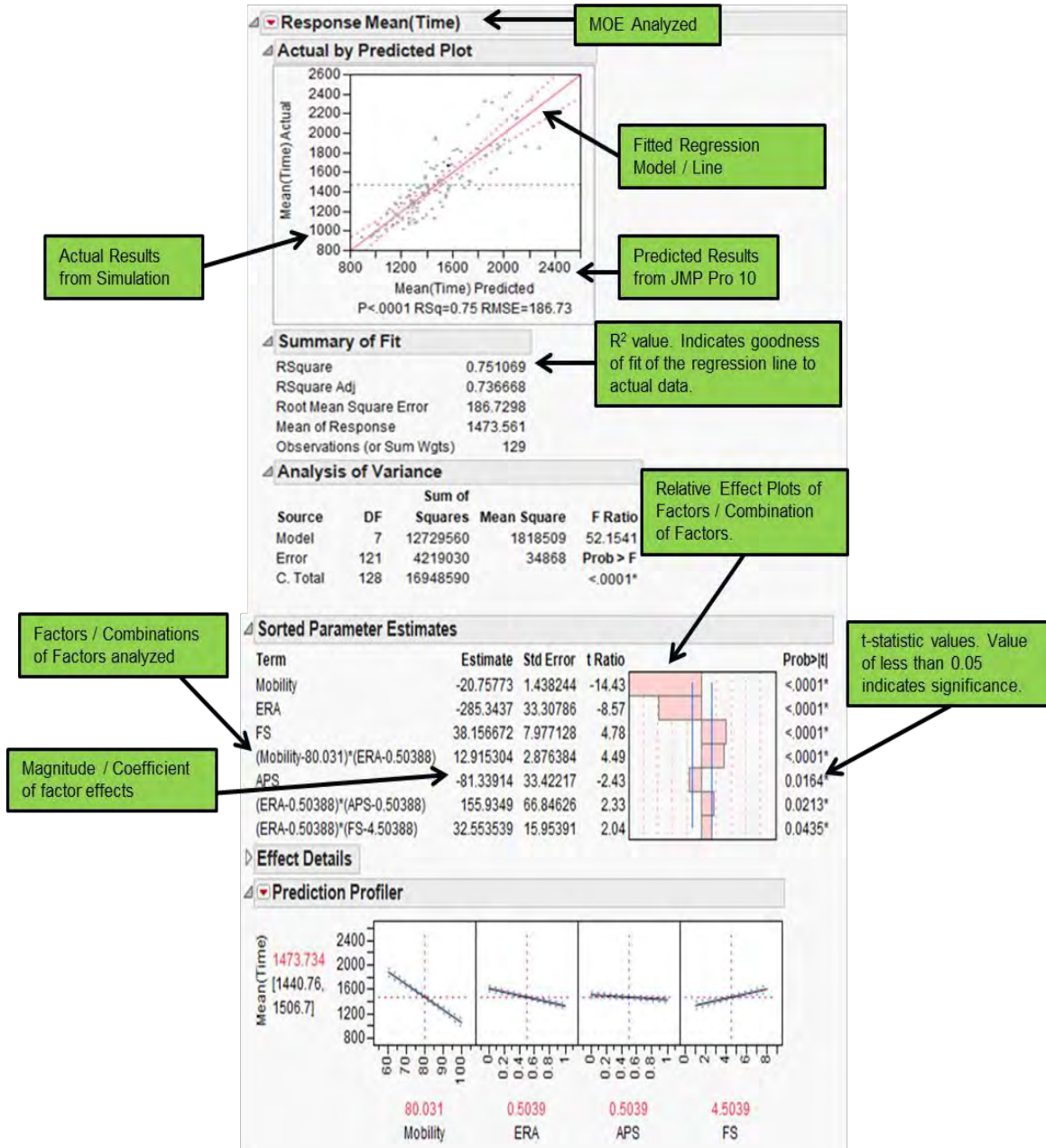

Figure 28. JMP output example.

The following two measures were used to indicate and measure the significance of the results obtained.

## **1. R<sup>2</sup> Value**

The coefficient of determinant, also known as the R<sup>2</sup> value, provides a goodness-of-fit measure. It indicates the proportion of the total variation of a dependent variable around its average that is accounted for by the independent variable in a regression function (Ragsdale 2012). The R<sup>2</sup> value ranges from the lowest value of 0 to the maximum value of 1.

The analysis of the simulation data was performed with the fitting of a regression line. A high R<sup>2</sup> value would indicate that the data points are closer to the fitted regression line. This implies that most of the observed data can be explained by the fitted model. A R<sup>2</sup> value that can be considered “good” is typically above 0.7 (Hayter 2012).

## **2. t-Statistic**

The “discrepancy” between the data set and the null hypothesis is measured through a t-statistic (Hayter 2012, 354).

The value of the t-statistic lies in the fact that it provides a probability of any further data point that will fall outside of the notional range of value at a certain confidence interval (Hayter 2012), assuming that the null hypothesis is correct. For example, at a 95% confidence interval for any set of data under regression analysis, a t-statistic of value 0.01 would mean that there is only a 1% probability that any further observed data would fall outside the boundary of the notional range of 95% of all data points. A value of t-statistic that is larger than (1 – 95%) would render the factor insignificant. Hence, the smaller the value of the t-statistic, the more likely is it to be close to the notional value and the more significant it is. As the analysis of results uses a 95% confidence interval, factors with a t-statistic value of less than 0.05 would be considered to have significant effect on the outcome of the respective MOEs.

## **B. INITIAL SIMULATION RESULTS**

A total of 128 different sets of simulations, each with 50 repetitions, were conducted as an initial foray into the research. The results were analyzed using the statistical software, JMP Pro 10, and the analysis is discussed in the subsequent paragraphs. The generated design points for the initial simulations, along with the simulation results, are illustrated in Appendix B.

### **(1) Main Effect Model**

During the analysis of the results from the initial simulations, only the Main Effects, which are effects of individual factors without any interactions with other factors, of the model were being considered.

### **(2) Analysis of Main Effects on MOEs**

The effects of the factors on the various MOEs are discussed in the following sections.

### (3) Percentage BLUE Casualties

As observed in both Figure 29. and Figure 30. the model has a good fit with a high  $R^2$  value of 0.75836. This means that a large proportion of the data points (actual results from the simulation) are being accounted for and explained by the predicted model that is used to fit the regression line, and the model is accurate in predicting the outcomes of the MOE. In addition, the factors that are significant in determining the outcome of this particular MOE (at 95% confidence interval) are Armor Thickness (%), Presence of APS, Presence of ERA, Mobility (%), and Force Structure as the value of their respective t-statistic (Prob > |t|) is below that of 0.05.

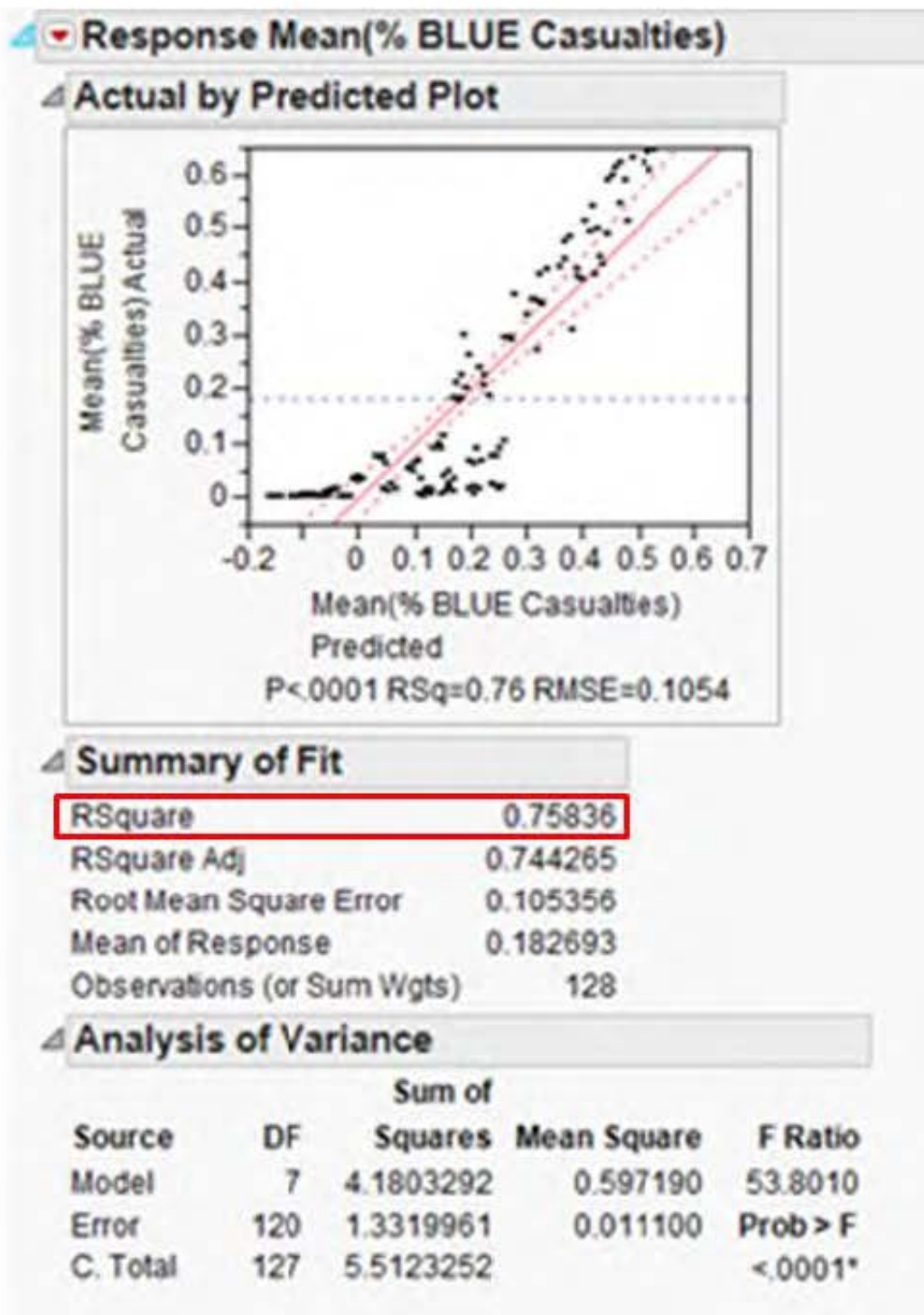

Figure 29. Initial regression results for MOE - % BLUE Casualties.

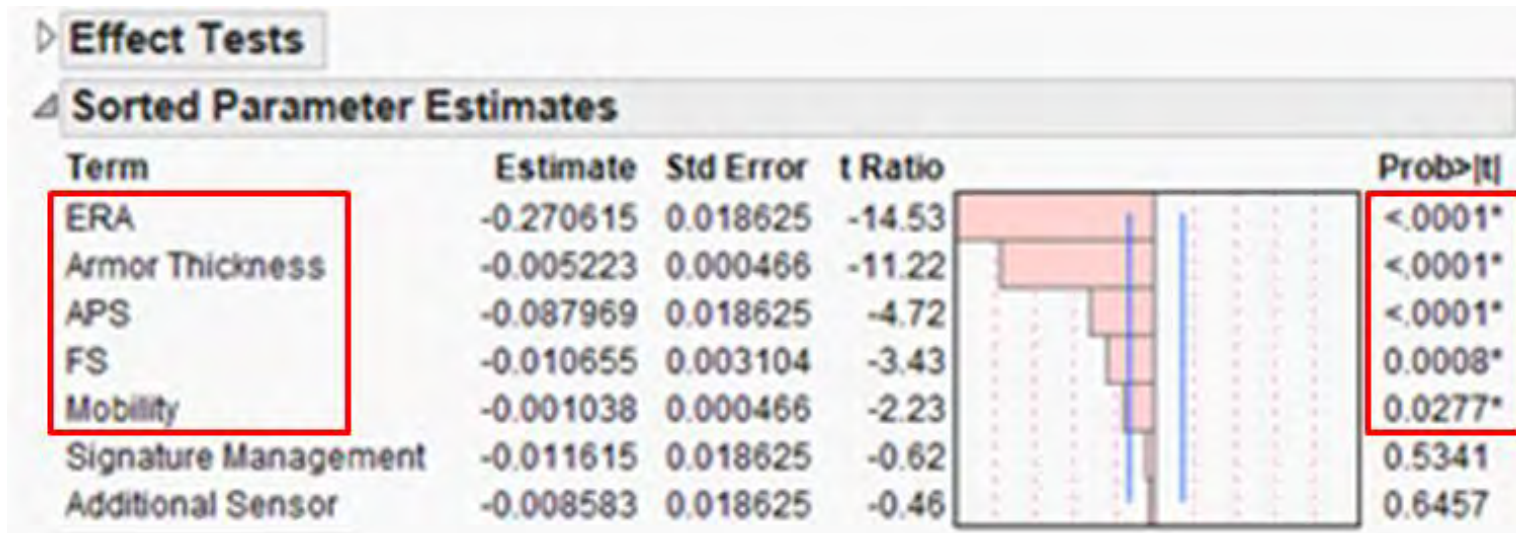

Figure 30. Parameter estimates for MOE – % BLUE Casualties.

***b. Force Exchange Ratio***

As observed in both Figure 31. and Figure 32. the model has a good fit with a high  $R^2$  value of 0.746795. This means that a large proportion of the data points (actual results from the simulation) are being accounted for and explained by the predicted model that is used to fit the regression line, and the model is accurate in predicting the outcomes of the MOE. In addition, the factors that are significant in determining the outcome of this particular MOE are Armor Thickness (%), Presence of APS, Presence of ERA, and Force Structure as the value of their respective t-statistic (Prob > |t|) is below that of 0.05.

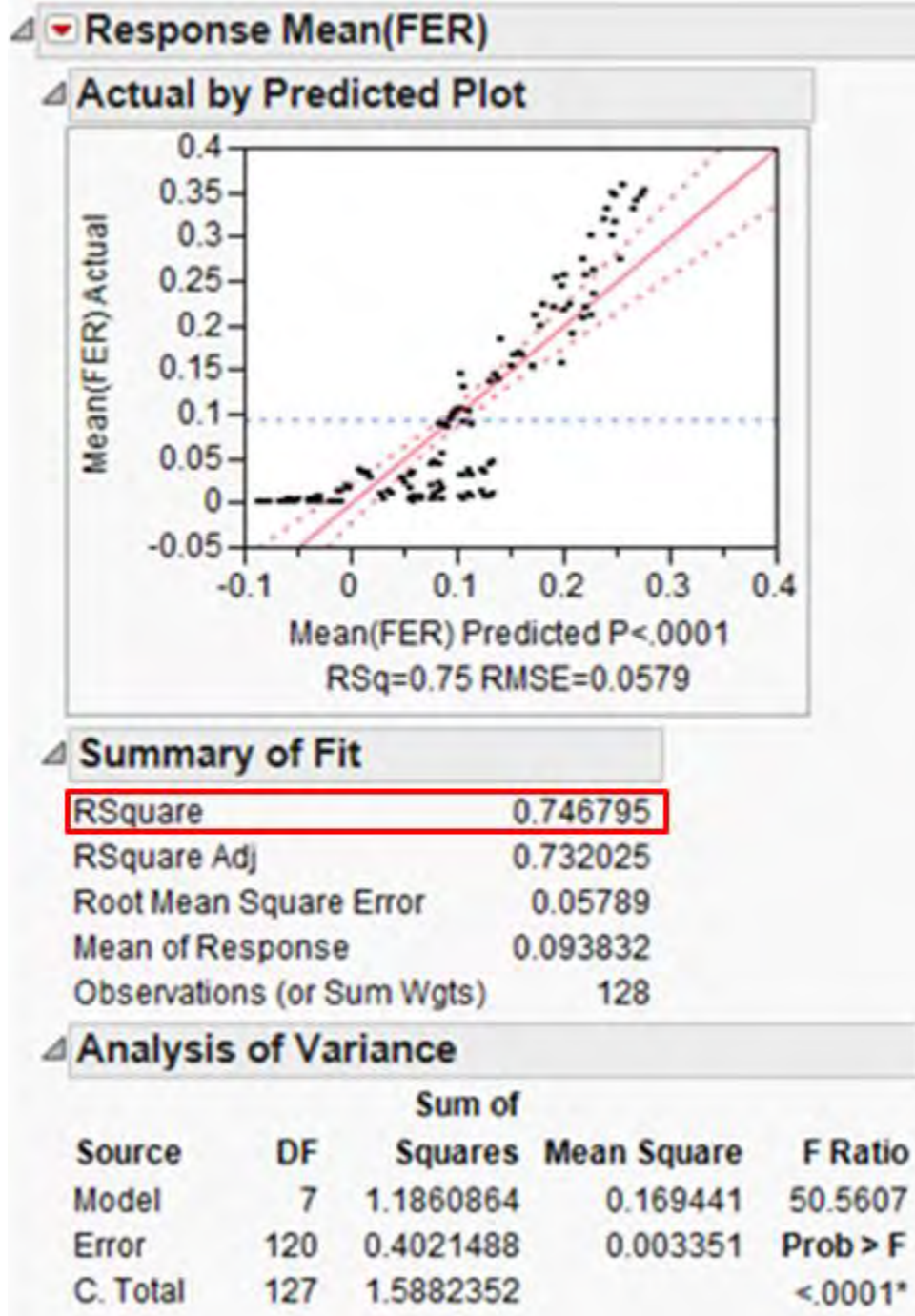

Figure 31. Initial regression results for MOE – FER.

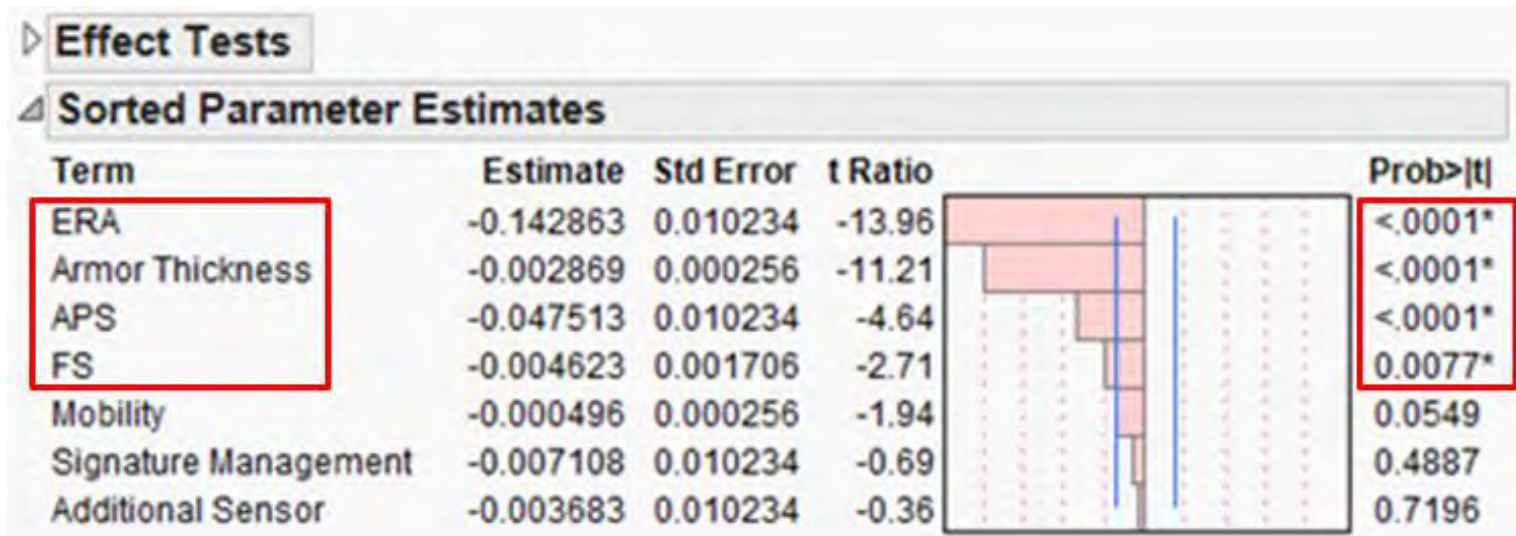

Figure 32. Parameter estimates for MOE – FER.

*c. Probability of Completing Mission*

As observed in both Figure 33. and Figure 34. the model has an average fit with an  $R^2$  value of 0.589924. This means that approximately half of the data points (actual results from the simulation) are being accounted for and explained by the predicted model that is used to fit the regression line, and the model is less accurate in predicting the outcome of the MOE. In addition, the factors that are significant in determining the outcome of this particular MOE are Armor Thickness (%), Presence of APS, Presence of ERA, and Mobility (%) as the value of their respective t-statistic (Prob > |t|) is below that of 0.05.

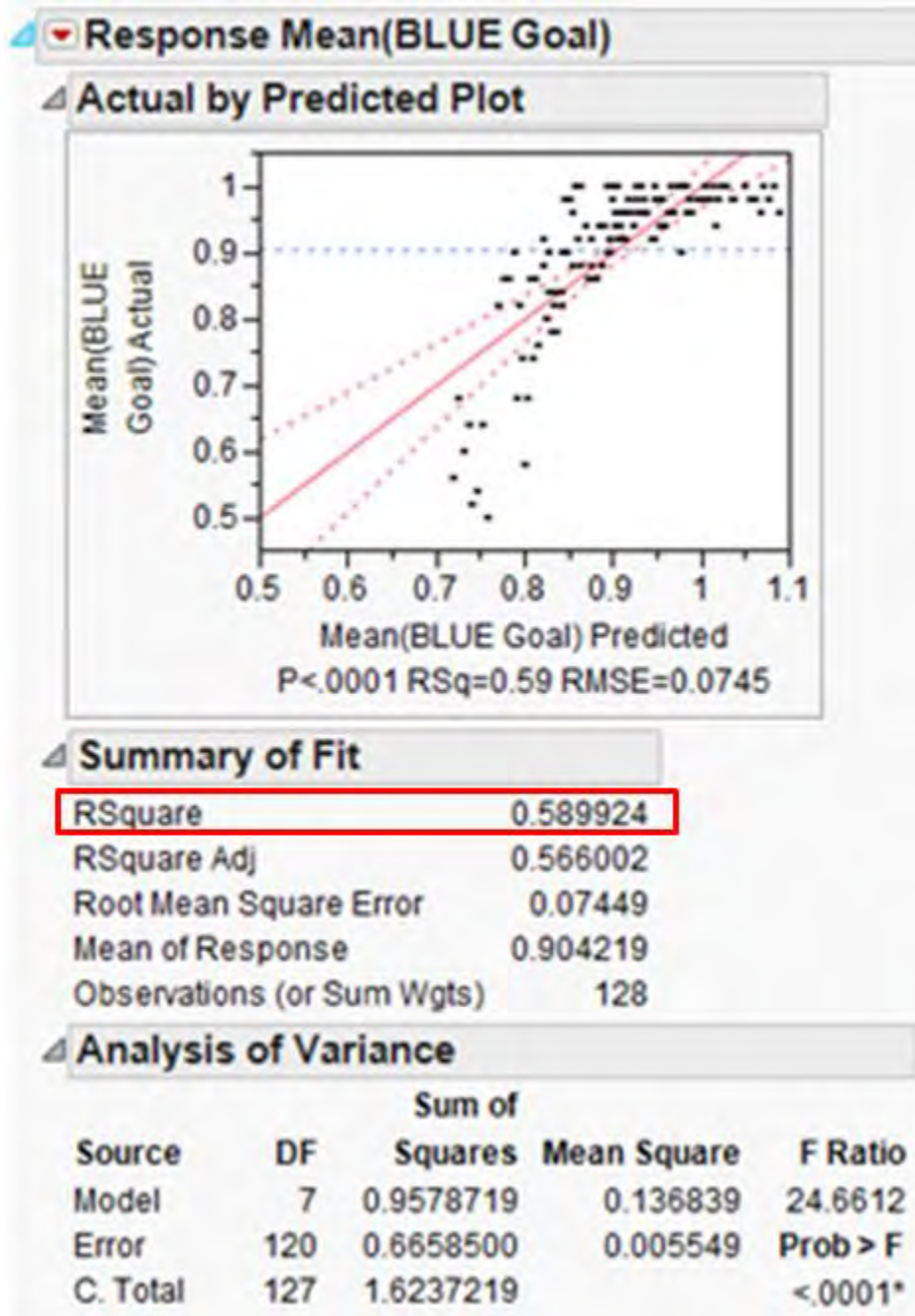

Figure 33. Initial regression results for MOE – Probability of Completing Mission.

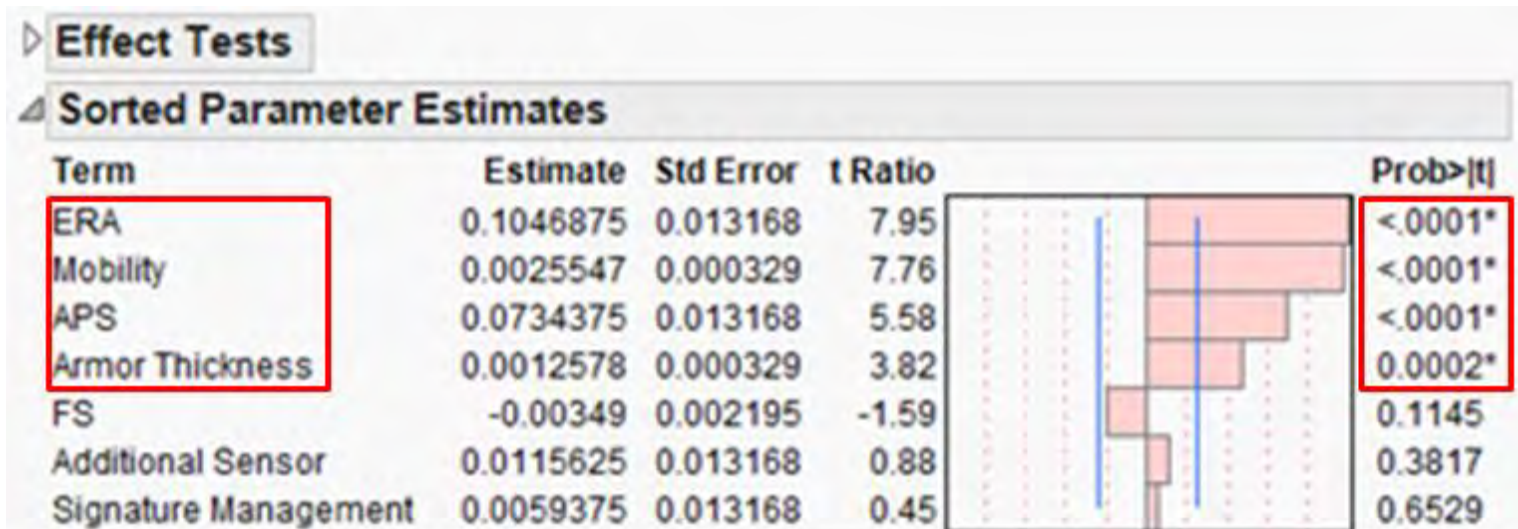

Figure 34. Parameter estimates for MOE – Probability of Completing Mission.

***d. Time Steps taken to Complete Mission***

As observed in both Figure 35. and Figure 36. the model has an excellent fit with a high  $R^2$  value of 0.935199. This means that almost all of the data points (actual results from the simulation) are being accounted for and explained by the predicted model that is used to fit the regression line, and the model is very accurate in predicting the outcome of this MOE. In addition, the factors that are significant in determining the outcome of this particular MOE are Armor Thickness (%), Presence of APS, Presence of ERA, Mobility (%), and Force Structure as the value of their respective t-statistic (Prob > |t|) is below that of 0.05.

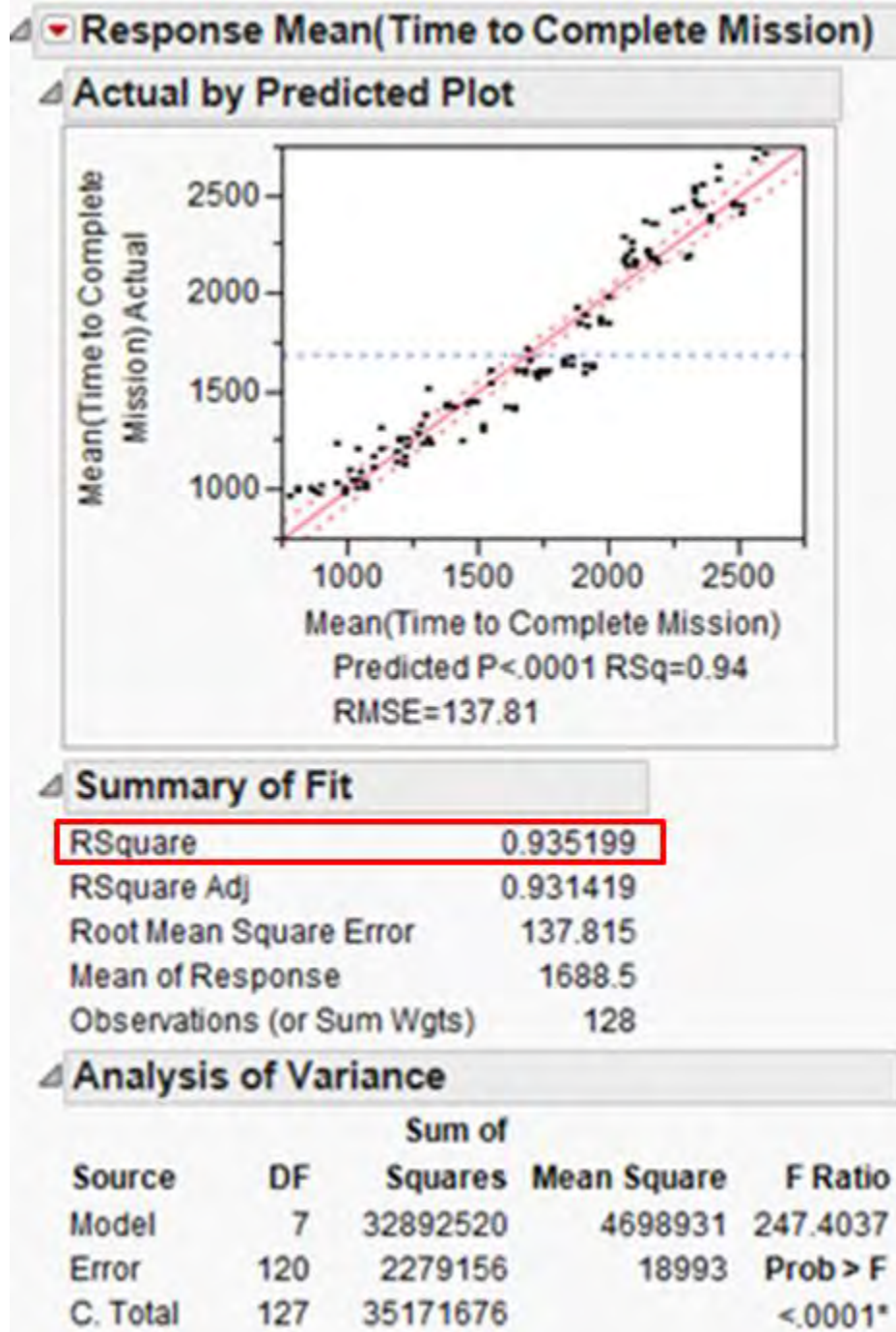

Figure 35. Initial regression results for MOE – Time steps taken to Complete Mission

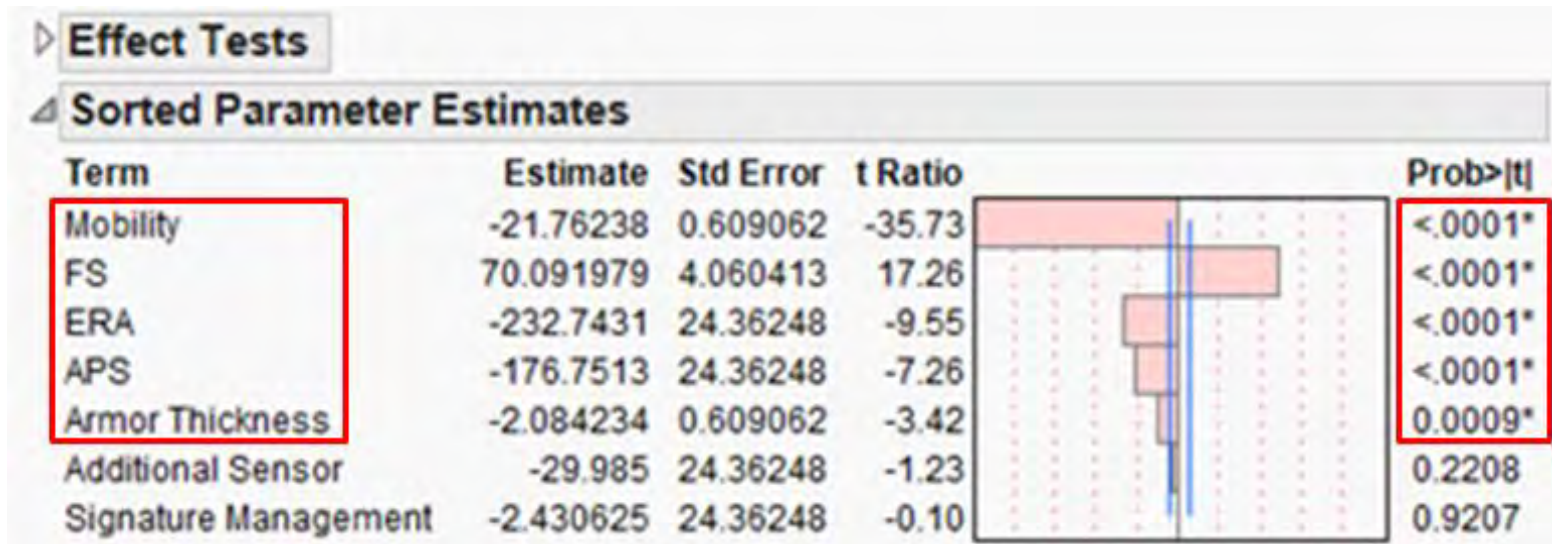

Figure 36. Parameter estimates for MOE – Time steps taken to Complete Mission.

*e. Most Important Main Effects*

It can be observed from the previous analysis that each MOE has largely the same design factors that are significant in determining its outcome. A summary of the initial results is provided in Table 7.

Table 7. Summary of design factors that are significant in determining the outcome of the respective MOEs based on t-statistic values (Green = Very Significant, Yellow = Significant, Orange = Not so Significant, Red = Not Significant)

MOEs	Significance of Design Factors						
	Armor Thickness %	APS	ERA	Mobility %	Signature Management	Additional Sensor	Force Structure
% BLUE Casualties	Green	Green	Green	Yellow	Red	Red	Yellow
FER	Green	Green	Green	Red	Red	Red	Yellow
Prob of Completing Mission	Yellow	Green	Green	Green	Red	Red	Red
Time Steps taken to Complete Mission	Yellow	Green	Green	Green	Red	Red	Green

*f. Insignificant Factors*

While the significance of the factors Armor Thickness (%), Presence of APS, Presence of ERA, Mobility (%), and Force Structure will be discussed after further and more refined analysis, the insignificance of the two factors in any of the four MOEs, Presence of Signature Management and Presence of Additional Sensors, warrants an explanation.

(1) Presence of Signature Management

As previously discussed, the urban terrain is a very cluttered and dense environment, with range of observation and engagement often being limited to less than a few hundred meters. The effect of Signature Management is largely to minimize the

infrared (IR) signature of the armored vehicle and reduce its detection by the adversary's thermal sighting system from a distance away.

This effect is largely negated in the urban environment as the acquiring of targets is often being accomplished by the naked eye and the optical sighting system present on the platform, due to the short distances of observation and engagement presented by the urban clutter.

Hence, the presence of Signature Management measures does little to contribute to reducing the casualties count and the Force Exchange Ratio. The increase in friendly casualties will result in the reduction of combat fit units and no doubt lead to the reduction in the ability of the unit to accomplish its mission and the time taken to do so.

#### (2) Presence of Additional Sensor

The insignificance of having an additional sensor can again be attributed to the unique and cluttered characteristics of an urban environment. No doubt having an additional sensor in the form of an UAV will provide the ground forces with an increased detection range; the urban environment permits only short engagement ranges of less than a few hundred meters. The advantage of being able to "see" far is negated by the inability of the ground units to shoot far in an urban environment.

Hence, the presence of an additional sensor does little to affect the results of the engagements and is insignificant in the determination of the outcomes of the various MOEs.

### **C. REFINED SIMULATION RESULTS**

Based on the results of the initial simulations, where the following design factors Armor Thickness (%), Presence of APS, Presence of ERA, Mobility (%), and Force Structure are determined to be significant, a further refined sets of design points were obtained using the NOLH as discussed in Chapter III. This approach further generated 129 sets of different simulations, each with 50 repetitions to ensure statistical significance. The results were also analyzed using JMP Pro 10 and are discussed in the

following sections. The generated design points for the refined simulations, along with the simulation results, are illustrated in Appendix B.

## **1. Pair Wise Analysis of Results Based on MOEs**

The author acknowledges that it is insufficient to merely analyze the main effects of the five significant factors on the MOEs. Analysis of the interactions and combined effects of the factors must be performed for a more holistic and accurate study.

### ***a. Percentage BLUE Casualties***

Based on Figure 37. the model is deemed to have a good fit with a high  $R^2$  value of 0.861881. This means that a large proportion of the data points (actual results from the simulation) are being accounted for and explained by the predicted model that is used to fit the regression line, and the model is accurate in predicting the outcomes of the MOE.

It is also observed from Figure 38. that there are ten factors and combinations of factors with  $\text{Prob } >|t|$  smaller than 0.05. This means that there is more than 95% confidence that the factors or combinations of factors are really significant in affecting the output of the MOE.

However, there are several factors that are beneficial (decreasing the percentage casualties of BLUE forces) in terms of improving the MOE while some are detrimental and they are analyzed in the following subsection.

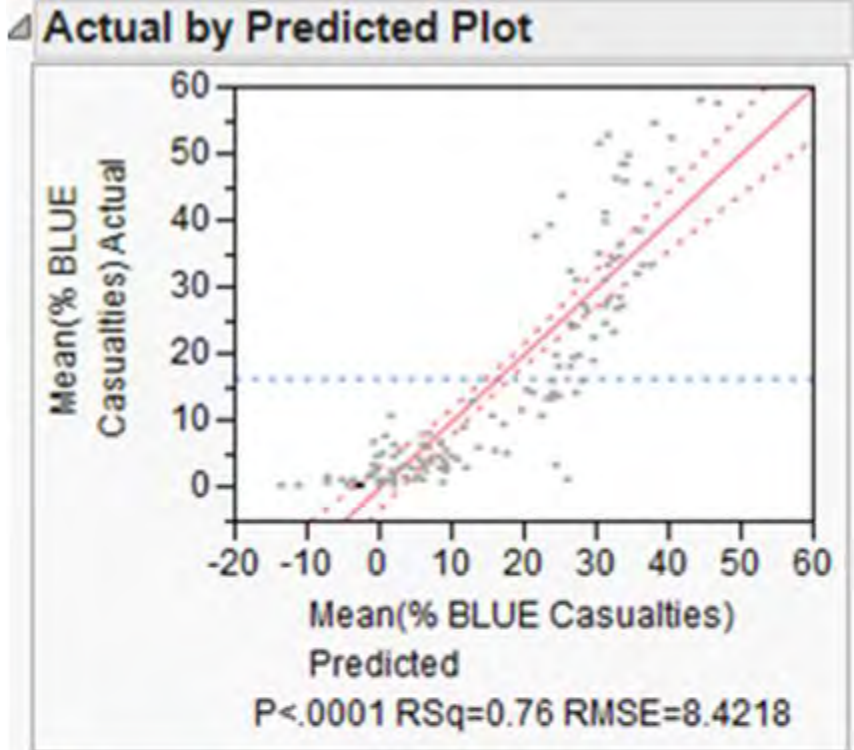

**Summary of Fit**

RSquare	0.760718
RSquare Adj	0.750991
Root Mean Square Error	8.421803
Mean of Response	16.44212
Observations (or Sum Wgts)	129

**Analysis of Variance**

Source	DF	Sum of Squares	Mean Square	F Ratio
Model	5	27734.985	5547.00	78.2074
Error	123	8723.993	70.93	Prob > F
C. Total	128	36458.978		<.0001*

Figure 37. Pair-wise regression results for MOE - % BLUE Casualties.

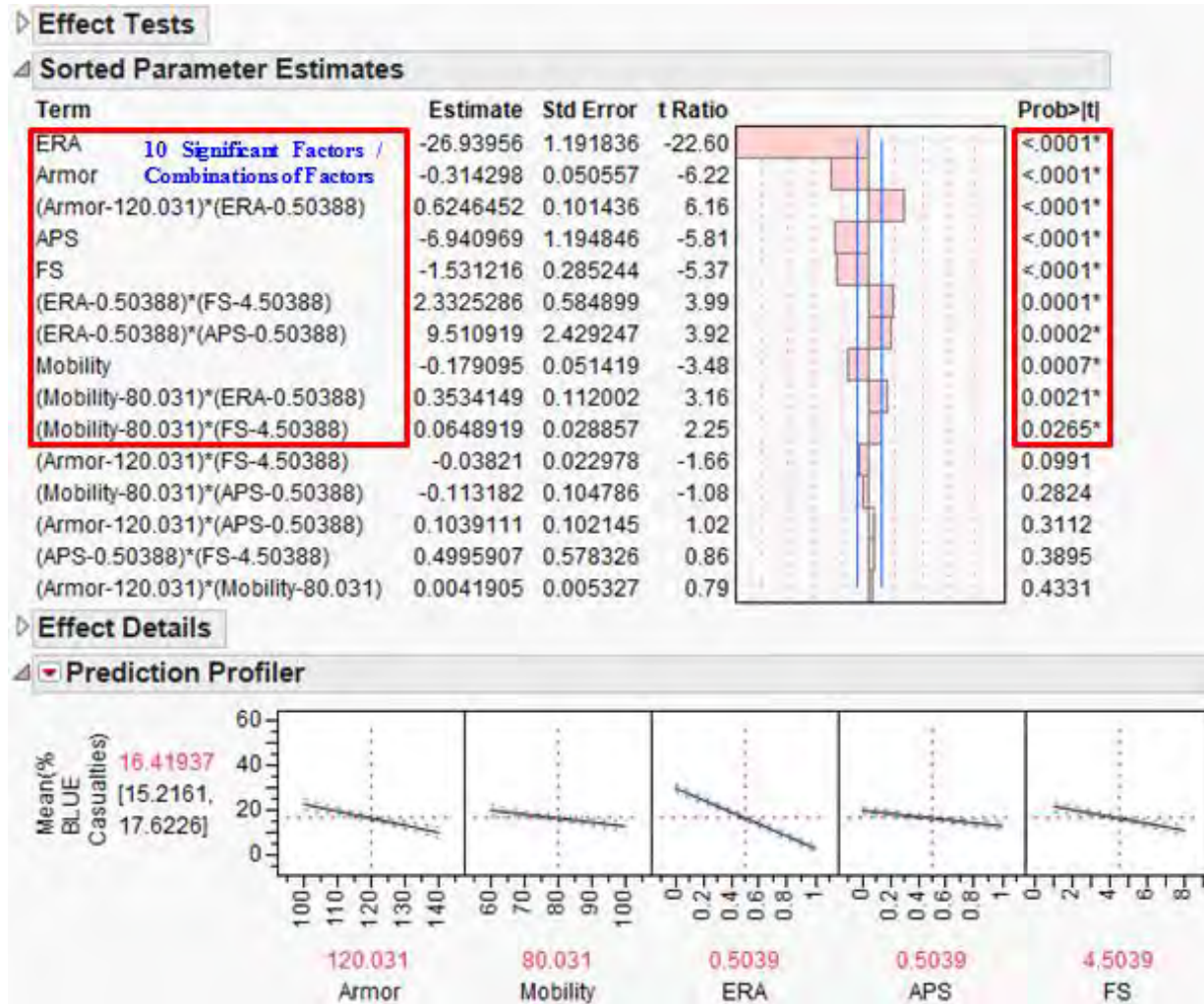

Figure 38. Effects of the factors and combinations on MOE - % BLUE Casualties.

### (1) Beneficial Factors and Combinations

The following factors are beneficial to the outcome of the MOE:

- Armor Thickness (%)
- Presence of Active Protection System (APS)
- Presence of Explosive Reactive Armor (ERA)

The armor of a vehicle and the presence of ERA or APS are the attributes that are designed to increase the survivability of the vehicle. Hence, it is of no surprise that with increasing Armor Thickness, having the presence of APS or ERA, will improve the MOE and reduce the percentage of casualties taken by the BLUE units.

### (2) Mobility (%)

Mobility, as discussed earlier, can be viewed as a form of passive defensive measures. The axiom of the faster the target is moving, the more difficult it is to hit the target is apparent in this instance. Hence, increasing the Mobility of a vehicle will improve the chances of it not being hit and becoming a casualty.

### (3) Force Structure

In terms of Force Structure, the higher the assigned number, the more “powerful” is the force structure of the Armored Company Team. This will improve the lethality of the BLUE units, resulting in improved survivability and, in turn, benefits the MOE by reducing the casualties taken by the BLUE forces.

### (4) Detrimental Factors and Combinations

The following combinations of factors are detrimental to the outcome of the MOE:

- Armor Thickness (%) and Presence of ERA

The detrimental effect of the combination of the factors Armor Thickness (%) and the Presence of ERA can be attributed to the fact that the interaction of the two factors negates the benefits of each individual factor. ERA was designed to circumvent the pitfall of having to continually increase the Armor Thickness for greater protection by providing an asymmetrical solution. Having ERA, which has substantial weight in itself, and yet

continually increasing the Armor Thickness will no doubt increase the total weight of the platform and decrease the mobility of the platform, hence subjecting the platform to a higher probability of being spotted, targeted, engaged, and hit by the enemy, leading to an increase in the casualties.

- Presence of ERA and Presence of APS

The detrimental combination of the factors Presence of ERA and Presence of APS can be explained by the fact that ERA and APS were each designed to be sufficient on its own. This would mean that the platform's survivability should be improved satisfactorily with either one of the two defensive attributes. Combining both yields no significant benefits while it decreases the mobility of the platform due to the increase in weight, hence again increasing the number of casualties.

- Mobility (%) and Presence of ERA

The combination of Mobility (%) and Presence of ERA is detrimental as well. The increase in casualties taken by the BLUE forces can be attributed to the resulting decrease in mobility of the platforms. The presence of the ERA will increase the weight of the platform and hence decrease its mobility.

- Mobility (%) and Force Structure

The combination of Mobility (%) and Force Structure is detrimental. The increase in the assigned Force Structure number would entail a force structure of heavier platforms for the BLUE forces, which inherently reduces its mobility. With mobility being viewed as a passive defense, the resultant decrease in mobility of the platforms due to the combination of the factors contributed to an increase in the percentage of BLUE casualties.

- Presence of ERA and Force Structure

The detrimental effects of combining the Presence of ERA and Force Structure are intriguing. Intuitively, the presence of ERA and a heavier force structure would improve the survivability of the BLUE forces. However, this is not in agreement with the regression results and the deviation from the expected intuitive observations can be attributed to the fact that the presence of ERA and a heavier force structure again

decreases the mobility of the BLUE forces, resulting in the increase in number of casualties taken.

- Effects of Factors

As observed in Figure 38. it can be concluded that the factors Presence of ERA and Armor Thickness (%) have the largest degree of effect, based on their steeper gradient in the prediction profiler and the relatively minute value of the t-statistic on the determination of the outcome of the MOE.

***b. Force Exchange Ratio (FER)***

Based on Figure 39. the model is deemed to have an average fit with an  $R^2$  value of 0.458333. This means that approximately half of the data points (actual results from the simulation) are being accounted for and explained by the predicted model that is used to fit the regression line, and the model is reasonably accurate in predicting the outcome of the MOE.

It also can be observed from Figure 40. that there are six factors and combinations of factors with Prob  $>|t|$  smaller than 0.05. This means that there is more than a 95% confidence that the factors or combinations of factors are really significant in affecting the output of the MOE.

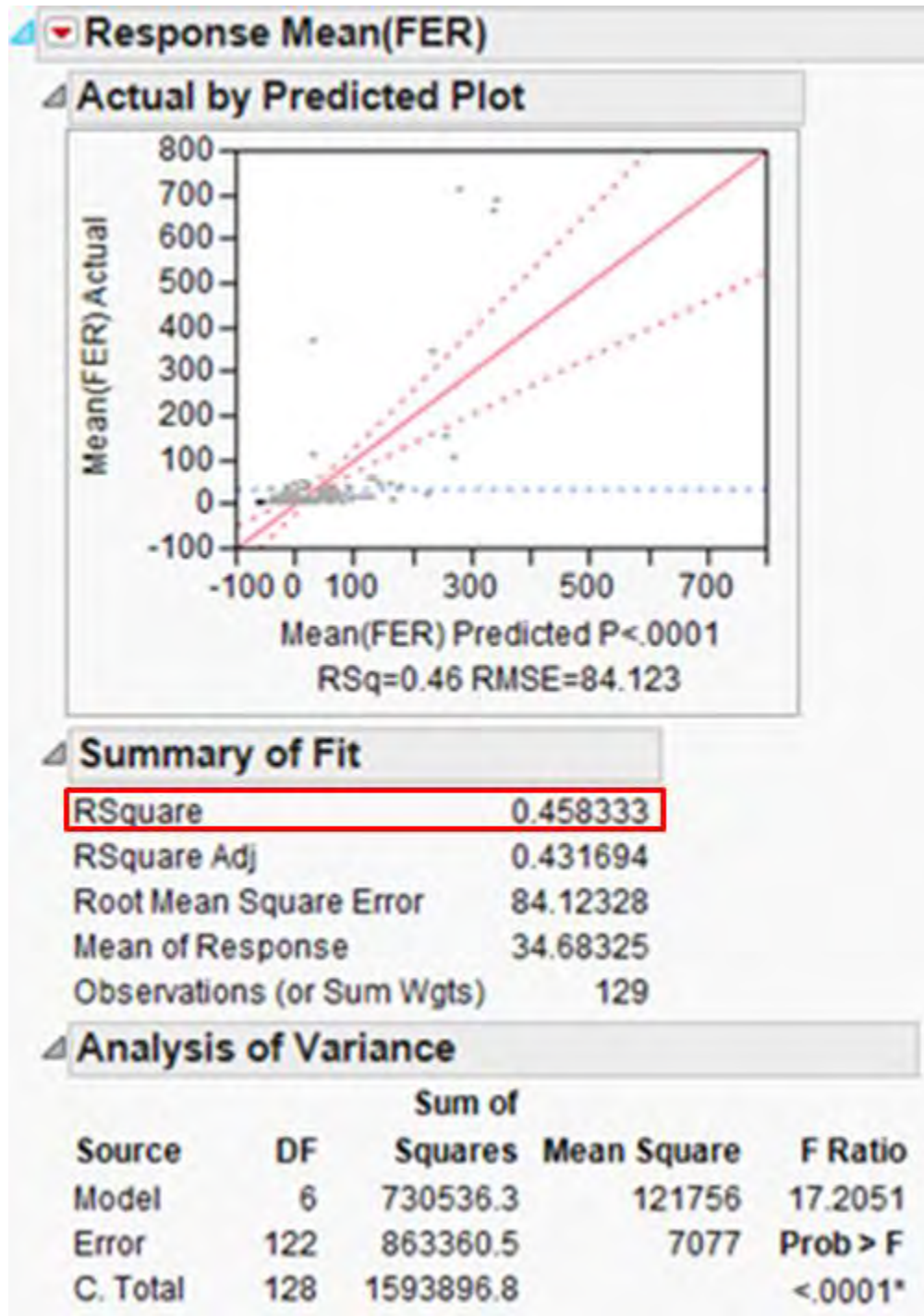

Figure 39. Pair-wise regression results for MOE – FER.

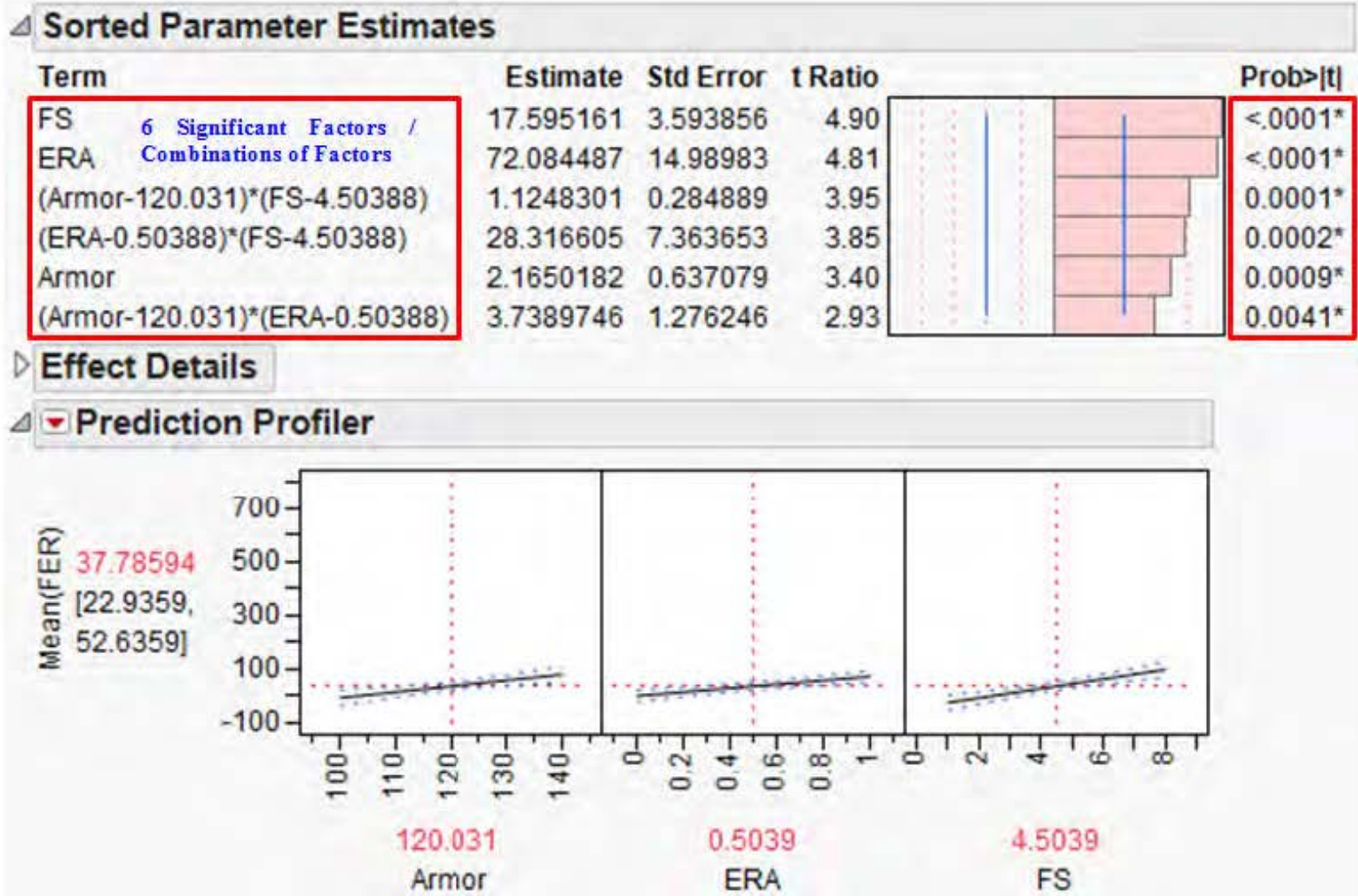

Figure 40. Effects of the factors and combinations on MOE – FER.

## (1) Beneficial Factors and Combinations

The following factors are beneficial to the outcome of the MOE:

- Armor Thickness (%)

The increasing thickness in armor will improve the protection and defensive capability of the platforms, hence improving their survivability. This allows the platform to stay in the conflict for a longer period of time, giving it more opportunities to engage and destroy enemy forces and, hence, it yields an increase in the FER. It is noted that the results obtained contradict the aforementioned MOE. The disparity of the results warrants further detailed study with more refined and improved simulations and design of experiments.

- Presence of ERA

Likewise, the presence of ERA will improve the survivability of the platform by requiring more hits to destroy the platform. This allows the platform to stay in the conflict for a longer period of time, giving it more opportunities to engage and destroy enemy forces and, hence, it yields an increase in the FER.

- Force Structure

With a heavier Force Structure, not only do the BLUE forces have better protection, which leads to more units being able to stay in the fight and inflict damage to the enemy as explained earlier, the firepower of the BLUE forces also correspondingly increases. The increase in firepower no doubt would improve the lethality of the BLUE forces, allowing them to destroy more of the enemy and increase the FER.

- Armor Thickness (%) and Presence of ERA

The simultaneous increase in Armor Thickness and installation of ERA on the platforms will lead to the BLUE forces having more units in the conflict, which causes more damage to the enemy and improves the FER. The initial explanation is that the increase in Armor and Presence of ERA will allow the BLUE forces to survive better, hence having more units in combat longer and bringing more firepower to bear on the

enemy and increasing the FER. However, the contradiction of these results with MOE #1 was noted and, as mentioned previously, this observation warrants further study.

- Armor Thickness (%) and Force Structure

The improvement in Armor Thickness and heavier Force Structure will concurrently improve the defensive capabilities and firepower of the BLUE forces. This improvement in Vulnerability and Lethality has the combined effect of allowing the BLUE forces to have more units in the fight to engage and destroy the enemies, which leads to an increase in the FER.

- Presence of ERA and Force Structure

Likewise, the presence of ERA and a heavier Force Structure will concurrently improve the defensive capabilities and firepower of the BLUE forces, allowing the BLUE forces to have more units in the fight to engage and destroy the enemies, which leads to an increase in the FER.

## (2) Effects of Factors

As observed in Figure 40. , it can be concluded that the factors Force Structure and Presence of ERA have the largest degree of impact on improving the FER based on their steeper gradient in the prediction profiler and the relatively minute value of the t-statistic.

- Probability of Completing Mission

Based on Figure 41. , the model is deemed to have a poor fit with a low  $R^2$  value of 0.299651. This means that only a small number of the data points (actual results from the simulation) are being accounted for and explained by the predicted model that is used to fit the regression line, and the model leaves much to be desired.

It also can be observed from Figure 42. that there are five factors and combinations of factors with Prob >|t| smaller than 0.05. This means that there is more than a 95% confidence that the factors or combinations of factors are really significant in affecting the output of the MOE.

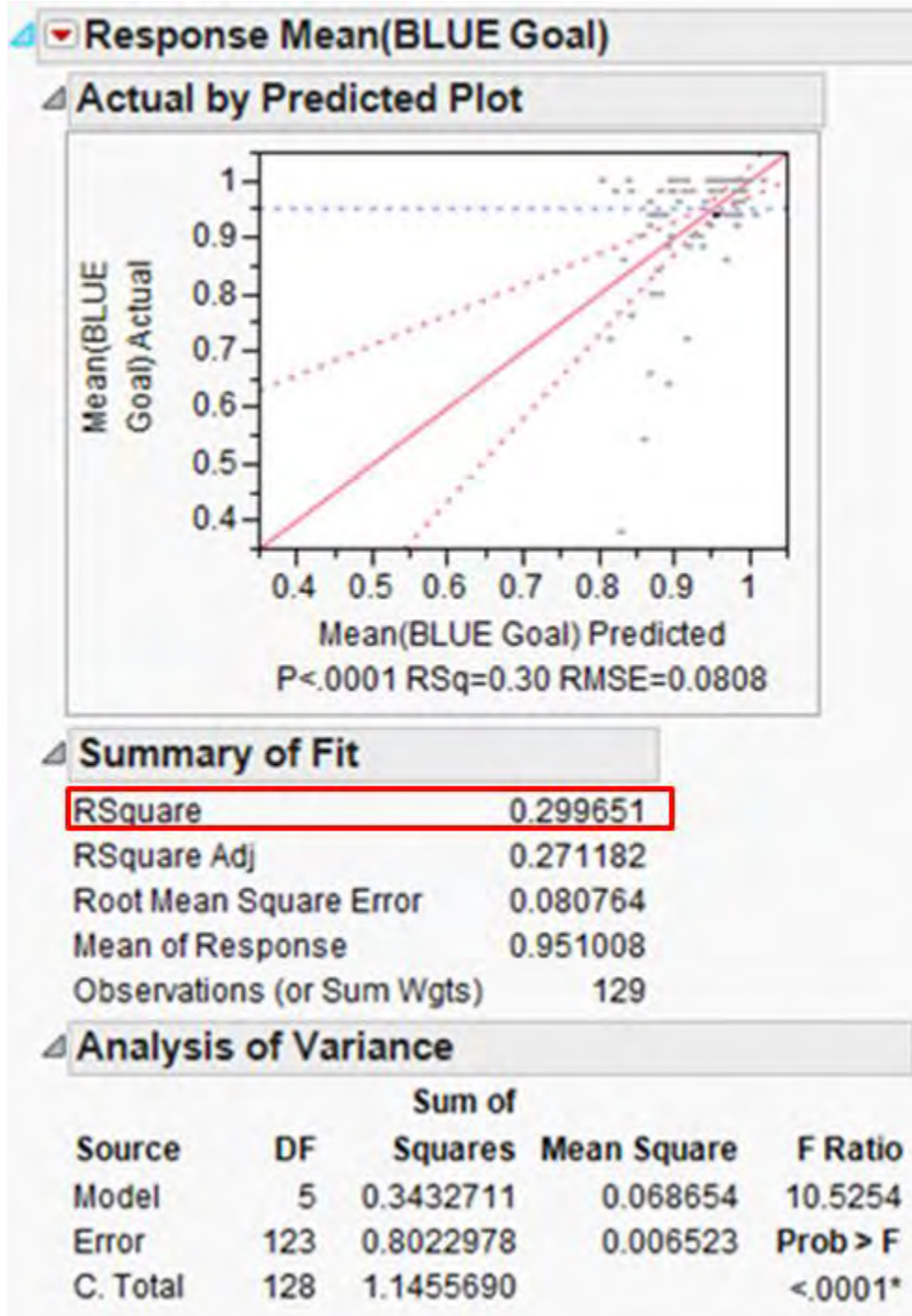

Figure 41. Pair-wise regression results for MOE–Probability of Completing Mission.

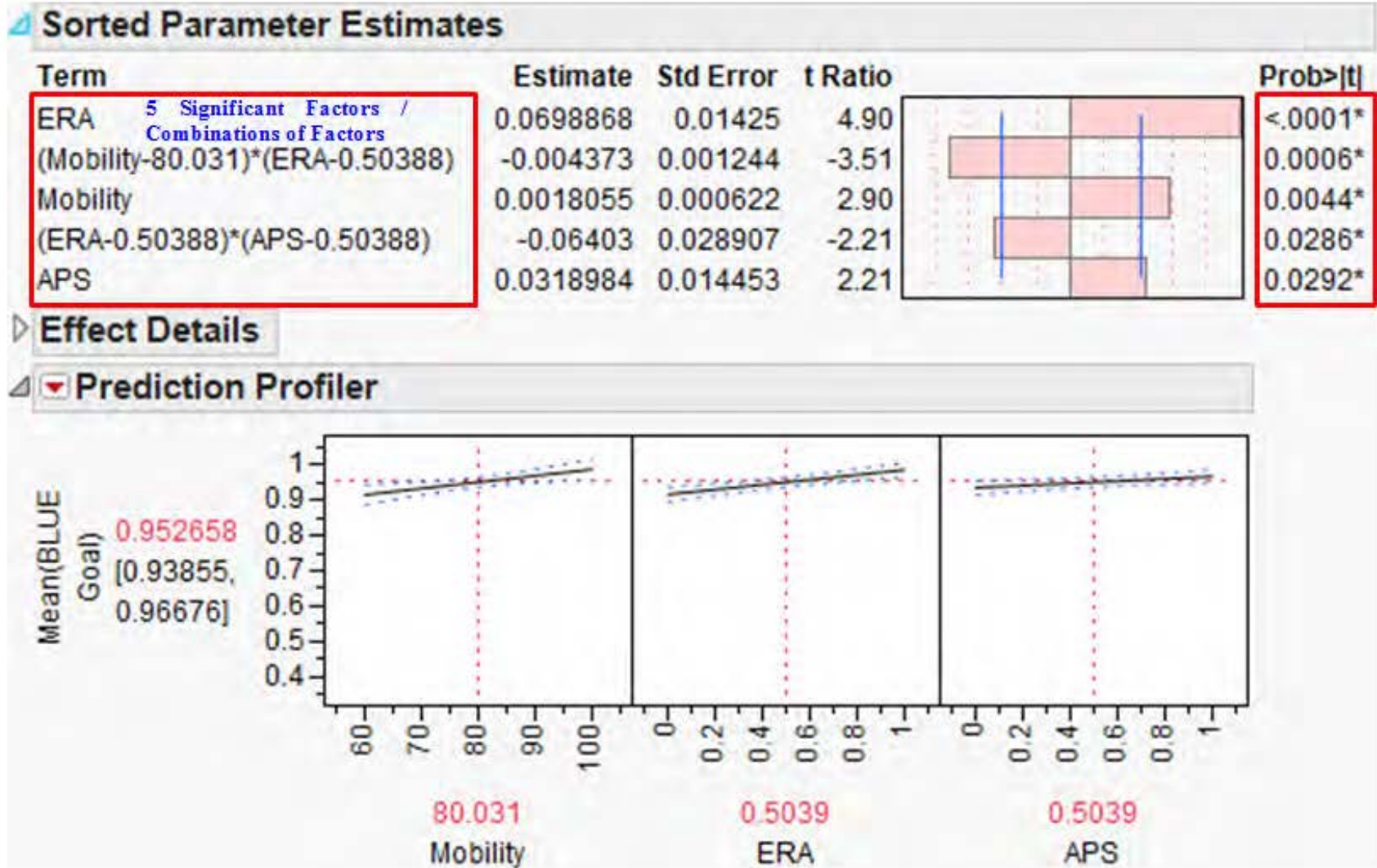

Figure 42. Effects of the factors and combinations on MOE–Probability of Completing Mission.

### (3) Beneficial Factors and Combinations

The following factors are beneficial to the outcome of the MOE:

- Mobility (%)

Mobility, as discussed earlier, is perceived to be a passive defensive measure (Sher, Refael and Luria 1988). The higher the mobility of a platform, the faster it can move and the harder it is for an enemy to effectively spot, target, engage, and hit it. This, in turn, improves the survivability of the platform by decreasing its Susceptibility. With improved survivability, the BLUE forces would have more units in the mission, and hence, there is a greater probability of the mission being accomplished.

- Presence of ERA and Presence of APS

ERA and APS are defensive measures to improve the survivability of a platform by improving its Vulnerability and Susceptibility. The presence of either measure will allow the BLUE forces to reduce the number of casualties taken, which allows the BLUE forces to have more units in the operation. This, in turn, increases the probability of the BLUE forces accomplishing their mission.

### (4) Detrimental Factors and Combinations

- Mobility (%) and Presence of ERA

The presence of ERA, with its inherent substantial weight, will increase the total weight of the platform and hence decreases the platform's mobility. With decrease in mobility, the BLUE forces are more likely to be engaged and destroyed by the enemy, rendering it to have fewer units that are combat effective in the operation. With that decrease, the probability of the BLUE forces accomplishing their mission is lowered.

- Presence of ERA and Presence of APS

ERA and APS, as discussed earlier, are meant to be used separately as their combined deployment yields no better advantage. Instead, the additional weight of having both systems on a platform will again reduce the platform's mobility, causing the BLUE forces to suffer more casualties and having less combat effective units to accomplish their mission.

(5) Effects of Factors

As observed in Figure 42. , it can be concluded that the factors Presence of ERA and Mobility (%) has the largest degree of effect on improving the Probability of the BLUE forces to accomplish their mission, based on their steeper gradient in the prediction profiler and the relatively minute value of the t-statistic.

*c. Time Steps Taken to Complete Mission*

Based on Figure 43. the model is deemed to have a good fit with an  $R^2$  value of 0.751069. This means that a large proportion of the data points (actual results from the simulation) are being accounted for and explained by the predicted model that is used to fit the regression line, and the model is accurate in predicting the outcomes of the MOE.

It also can be observed from Figure 44. that there are seven factors and combinations of factors with Prob  $>|t|$  smaller than 0.05. This means that there is more than 95% confidence that the factors or combinations of factors are really significant in affecting the output of the MOE.

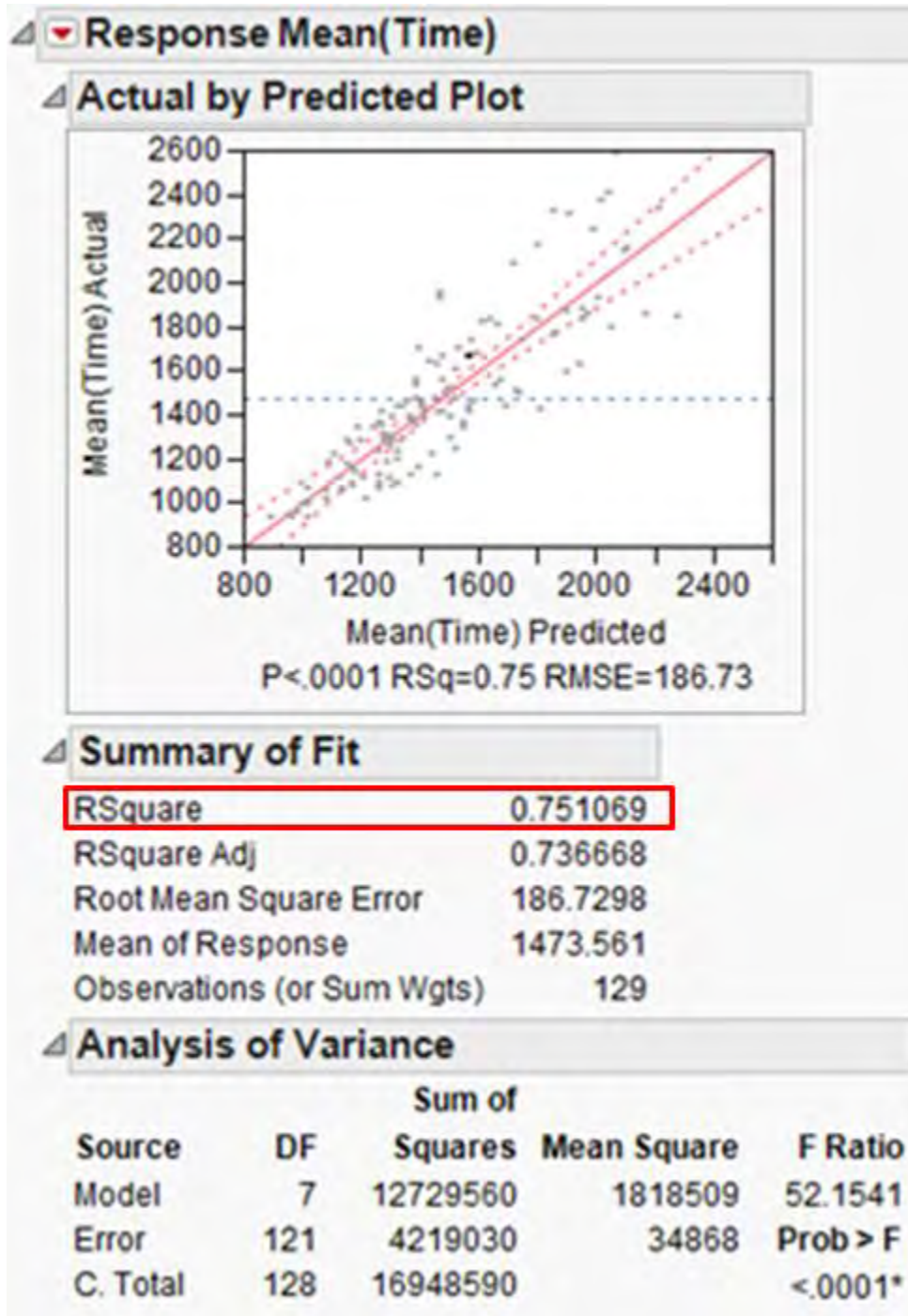

Figure 43. Pair-wise regression results for MOE – Time step taken to Complete Mission.

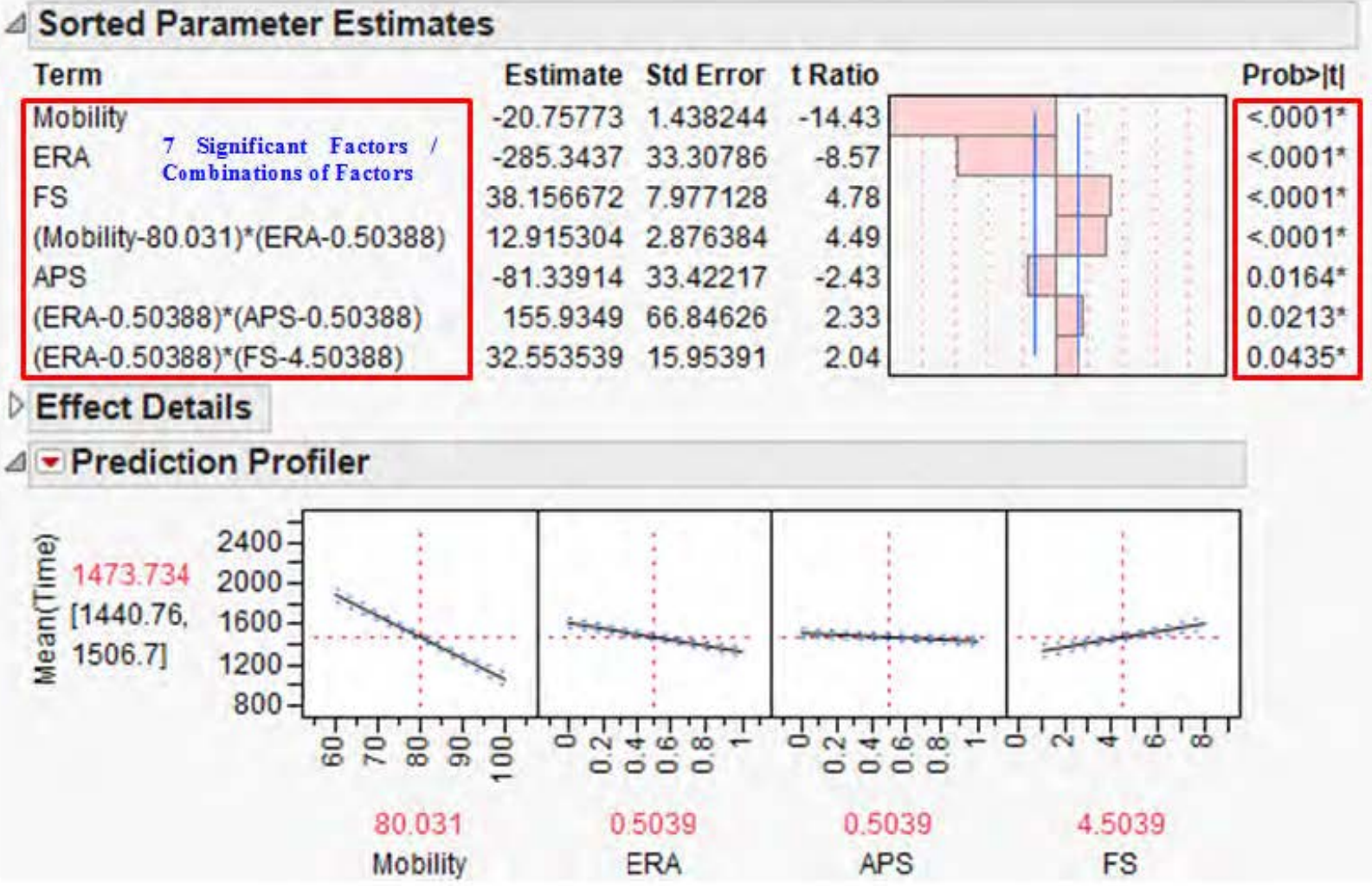

Figure 44. Effects of the factors and combinations on MOE – Time steps taken to Complete Mission.

## (1) Beneficial Factors and Combinations

The following factors are beneficial to the outcome of the MOE:

- Mobility (%)

With higher Mobility, the platform will be able to travel faster through the urban terrain towards its objective. Based on the mission success conditions defined earlier, the faster a BLUE force unit is able to reach the objective, the faster the mission is being accomplished. Hence, the increase in mobility would improve the MOE by reducing the number of time steps taken for the BLUE forces to accomplish its mission.

- Presence of ERA and Presence of APS

ERA and APS are defensive measures that allow the reduction in BLUE forces casualties, as discussed in earlier segments. The reduction in casualties means that the BLUE forces have more units at its disposal to accomplish the mission. This improvement in firepower would allow the BLUE forces to dispatch enemies more effectively and efficiently, resulting in less time being taken to capture the objective and complete the mission.

## (2) Detrimental Factors and Combinations

- Force Structure

With mobility being the key factor, having a heavier force structure with lower mobility would cause the BLUE forces to take a longer time in reaching their objective, and hence, more time steps are required in the simulation to accomplish the mission.

- Mobility (%) and Presence of ERA

Likewise, the presence of ERA with its inherent weight will lower the overall mobility of the BLUE forces. This, in turn, will increase the vulnerability of the BLUE forces. Having suffered from lower mobility already, the increase in vulnerability of the BLUE forces will mean that they have fewer combat effective units in the fight, which compounds the effect of having lower mobility, resulting in a longer time needed to accomplish the mission.

- Presence of ERA and APS

As explained earlier, the presence of both ERA and APS is detrimental, and the weight of both systems will reduce the mobility of the platforms. This would in turn result in a longer time taken for the BLUE forces to reach their objective and accomplish their mission.

- Presence of ERA and Force Structure

The presence of a heavier force structure will no doubt cause a decrease in mobility. As discussed earlier, the decrease in mobility will reduce the combat effectiveness of the BLUE forces by causing these forces to incur more casualties. This will in turn compound the undesired effect of requiring more time steps for the BLUE forces to reach their objective and accomplish the mission.

(3) Effects of Factors

As observed in Figure 44. , it can be concluded that the factors Mobility (%) and the Presence of ERA have the largest degree of effect on improving the time taken for the BLUE forces to accomplish the mission, based on their steeper gradient in the prediction profiler and the relatively minute value of the t-statistic.

A summary of the effects of the factors and the various combinations of factors on the MOEs is provided in 0

Table 8. Summary of the effect of the factors and various factors combinations on the MOEs (Green = Beneficial, Red = Detrimental, Black = N/A).

FACTORS & COMBINATIONS	MOES			
	% BLUE Casualties	FER	Prob of Completing Mission	Time Steps taken to Complete Mission
Armor Thickness (%)	Largest Effect on MOE			
Presence of APS				
Presence of ERA	Largest Effect on MOE	Largest Effect on MOE	Largest Effect on MOE	Largest Effect on MOE
Mobility (%)			Largest Effect on MOE	Largest Effect on MOE
Force Structure		Largest Effect on MOE		
Armor Thickness				
Armor Thickness (%) * Mobility (%)				
Presence of APS * Presence of ERA				
Mobility (%) * Presence of ERA				
Mobility (%) * Force Structure				
Presence of ERA * Force Structure				
Armor Thickness (%) * Presence of ERA				
Armor Thickness (%) * Force Structure				

## 2. MOE Equations

Based on the results of the regression analysis, a rudimentary equation that relates the factors can be established for each of the four MOEs.

$$\begin{aligned} \text{MOE \#1 - Percentage of BLUE Casualties} = & -0.3143 \times \text{Armor Thickness} \\ & (\%) - 0.1791 \times \text{Mobility}(\%) - 26.9396 \times \text{Presence of ERA} - 6.9410 \times \\ & \text{Presence of APS} - 1.5312 \times \text{Force Structure} + 0.62465 \times [\text{Armor} \\ & \text{Thickness} (\%)-120] \times (\text{Presence of ERA}-0.5) + 0.3534 \times [\text{Mobility} (\%) - \\ & 80] \times (\text{Presence of ERA}-0.5) + 0.06489 \times [\text{Mobility} (\%)-80] \times (\text{Force} \\ & \text{Structure}-4.5) + 9.5109 \times (\text{Presence of ERA}-0.5) \times (\text{Presence of APS}-0.5) \\ & + 2.3325 \times (\text{Presence of ERA}-0.5) \times (\text{Force Structure}-4.5) + 92.4468 \end{aligned} \quad (4)$$

$$\begin{aligned} \text{MOE \#2 - FER} = & 2.1650 \times \text{Armor Thickness} (\%) + 72.0845 \times \text{Presence of} \\ & \text{ERA} + 17.5951 \times \text{Force Structure} + 3.7390 \times [\text{Armor Thickness} (\%)-120] \\ & \times (\text{Presence of ERA}-0.5) + 1.1248 \times [\text{Armor Thickness} (\%)-120] \times (\text{Force} \\ & \text{Structure}-4.5) + 28.3166 \times (\text{Presence of ERA}-0.5) \times (\text{Force Structure}-4.5) \\ & - 337.6536 \end{aligned} \quad (5)$$

$$\begin{aligned} \text{MOE \#3 - Probability of Completing Mission} = & 0.001806 \times \text{Mobility} (\%) \\ & + 0.06989 \times \text{Presence of ERA} + 0.03190 \times \text{Presence of APS} - 0.004373 \times \\ & [\text{Mobility} (\%)-80] \times (\text{Presence of ERA}0.5) - 0.06403 \times (\text{Presence of} \\ & \text{ERA}0.5) \times (\text{Presence of APS}-0.5) + 0.7569 \end{aligned} \quad (6)$$

$$\begin{aligned} \text{MOE \#4 - Time Steps taken to Complete Mission} = & -20.7577 \times \text{Mobility} \\ & (\%) - 285.3437 \times \text{Presence of ERA} - 81.3391 \times \text{Presence of APS} + \\ & 38.1567 \times \text{Force Structure} + 12.9153 \times [\text{Mobility} (\%)-80] \times (\text{Presence of} \\ & \text{ERA}-0.5) + 155.9349 \times (\text{Presence of ERA}-0.5) \times (\text{Presence of APS}-0.5) + \\ & 32.5535 \times (\text{Presence of ERA}-0.5) \times (\text{Force Structure}-4.5) + 3147.9141 \end{aligned} \quad (7)$$

### a. MOE Equation Insights

The set of MOE equations is useful in providing the ground military commanders and planners an indication of the outcome of their land campaign or operations. This is achieved by substituting the equivalent numerical values of their military assets into the equation to derive a representative number on the outcome of the various MOEs.

In addition, it allows the planners and commanders to have an indication on the capability required of their assets in order to achieve certain desired levels of the MOEs in operations.

The output of the equations would further aid the military commanders and planners in making decisions and recommendations on the justifiability and the return of investment on the embarkation of military operations.

As an illustration on the fidelity of the equations, Equation (4), the equation for the MOE #1 – Percentage of BLUE Casualties and the data for design point #55 are being used as example. The values for the factors in design point #55 are as follows:

1. Armor Thickness (%) – 127
2. Mobility (%) – 98
3. Presence of ERA – 1
4. Presence of APS – 1
5. Force Structure – 5
6. Output value of MOE #1 for design point #55 in simulation is 5.00.

Upon entering the values of the factors into Equation (4), the derived value for MOE #1 is 4.54, which is reasonably close in comparison with the value obtained via simulation. This attests to the validity and fidelity of the derived MOE equations.

### **3. Partition Tree Analysis for Insights on MOEs**

In addition to the regression analysis, partition tree analysis of the results based on the four MOEs was further conducted. The partition tree function of the JMP Pro 10 software seeks to identify groups of values of the various factors that best predict the outcomes of the MOEs. It accomplishes this by recursively forming a decision tree until the desired emergence is achieved (SAS Institute 2012). The process is halted when the  $R^2$  value reaches an acceptable level of at least 0.7.

This effort is intended to make sense of the effects of the factors and identify the tipping point of the effects of various factors on the MOEs, which allows military

commanders and planners to make more informed decisions. The following analysis focuses on the output of the mean of the four listed MOEs.

a. *Percentage BLUE Casualties Insight*

The partition tree analysis for the MOE, Percentage BLUE Casualties, is illustrated in Figure 45.

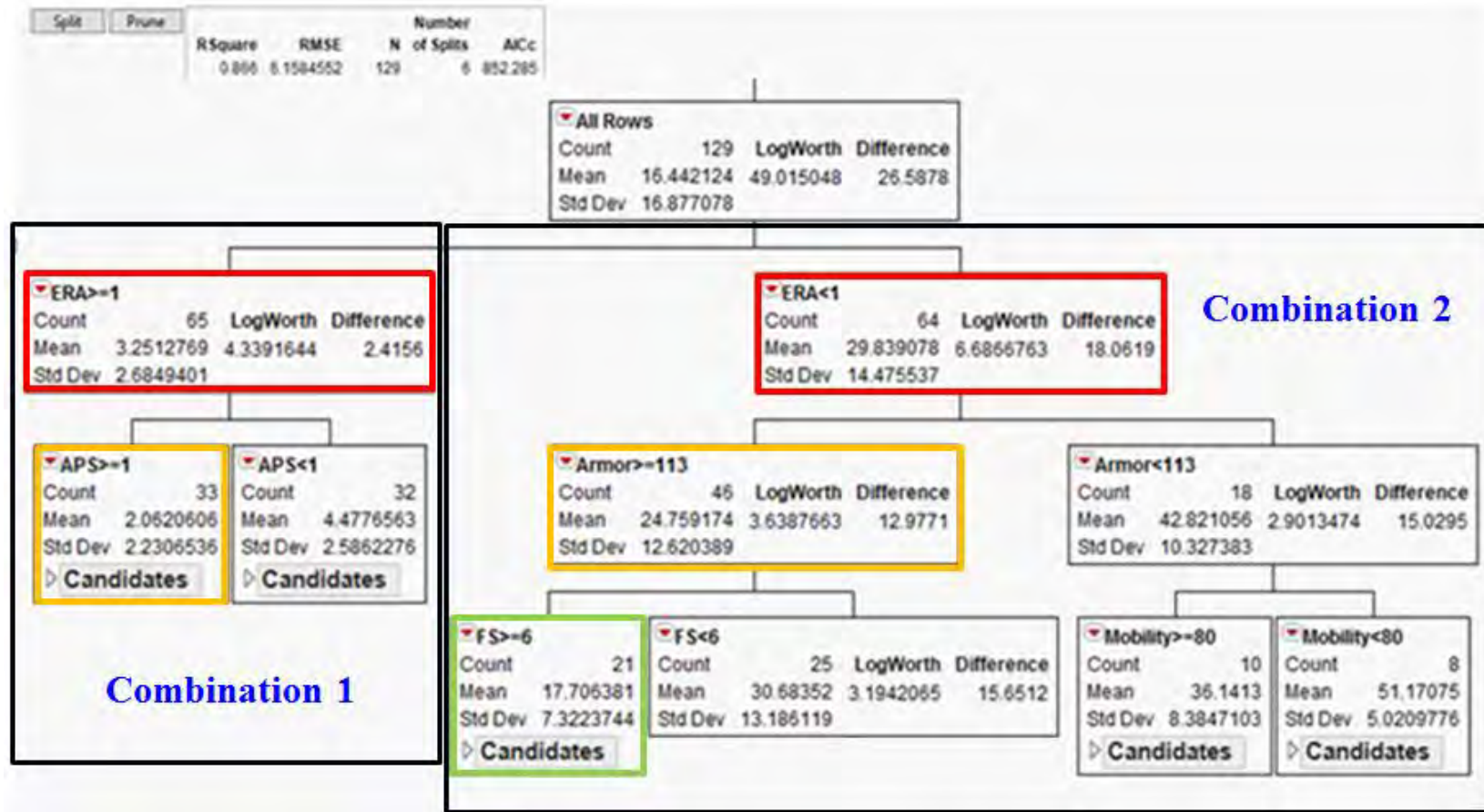

Figure 45. Partition tree analysis of MOE – % BLUE Casualties.

The main insight gleaned from this analysis is that the presence of ERA is of paramount importance in reducing the percentage of casualties for BLUE forces, with a difference of 26% fewer casualties when ERA is present. It is also observed that with the presence of ERA, there is little impact on the number of casualties sustained regardless of whether APS is present.

(1) Combination 1 – Percentage of BLUE Casualties sustained  $\approx$  Mean of 2.06 %

FACTORS	DESCRIPTION
Most Important	ERA $\geq$ 1 (Present)
2nd Most Important	APS $\geq$ 1 (Present)

Figure 46. MOE #1 factors of combination of choice – Combination 1

Combination 1, as illustrated in Figure 46. is the path of choice to improve the outcome of MOE #1 and to reduce the expected percentage of BLUE Casualties to be sustained as it yields the lowest percentage of casualties. The presence of ERA on the ground vehicles played a significant role in keeping the percentage of casualties sustained low (approximately 3.25%) compared to when ERA is absent (approximately 29.83%) as illustrated in Figure 47.

ERA $\geq$ 1 Count 65 Mean 3.2512769 Std Dev 2.6849401	LogWorth Difference 4.3391644 2.4156	ERA<1 Count 64 Mean 29.839078 Std Dev 14.475537	LogWorth Difference 6.6866763 18.0619
---	--------------------------------------	--	---------------------------------------

Figure 47. Combination 1 – Comparison of outcome of MOE #1 with the presence and absence of Explosive Reactive Armor.

In addition, the presence of APS installed on the ground vehicles will augment the performance of the ERA, decreasing the percentage of casualties further to approximately 2.06% as compared to when APS is absent with an approximate casualty rate of approximately 4.48% when APS is absent, as illustrated in Figure 48.

However, the disparity between the benefits (identified in this current section of the paper) and disadvantages (identified in an earlier section) of having both ERA and APS leaves room for further research.

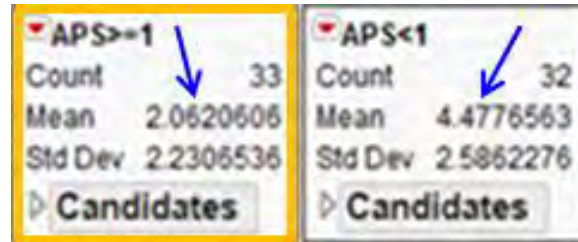

Figure 48. Combination 1 – Comparison of outcome of MOE #1 with the presence and absence of Active Protection System.

The decrease in the expected percentage of casualties sustained can be attributed to the defensive characteristics of both the ERA and APS, which improves the survivability of the platforms by reducing their susceptibility and vulnerability.

(2) Combination 2 – Percentage of BLUE Casualties Sustained  $\approx$  Mean of 17.7%

In Combination 2, the absence of ERA drastically increases the percentage of the casualties sustained to 29.89% as compared to 3.25% in Combination 1 where ERA is present.

In the event of ERA not being installed, it is important to equip the ground vehicles with passive armor that is approximately 113% as thick as that of the current armor mounted on the vehicles. Doing so will decrease the expected percentage of casualties to 24.7%. Failing to do so will increase the expected percentage casualties to 42.82% as illustrated in Figure 49.



Figure 49. Combination 2 – Comparison of outcome of MOE #1 with difference in Armor Thickness percentage.

To further reduce the expected casualties, it is important to have a force structure of value 6 (2 MBT platoons and 1 Stryker platoon). This measure will further decrease the expected percentage of casualties sustained to 17.7%. A heavier force structure would entail platforms with thicker armor and greater firepower, thus reducing the number of casualties sustained. A lighter force structure will result in higher casualties of approximately 30.68% as illustrated in Figure 50.



Figure 50. Combination 2 – Comparison of outcome of MOE #1 with difference in Force Structure.

**b. Force Exchange Ratio (FER) Insights**

The partition tree analysis for the MOE, Force Exchange Ratio, is illustrated in Figure 51.

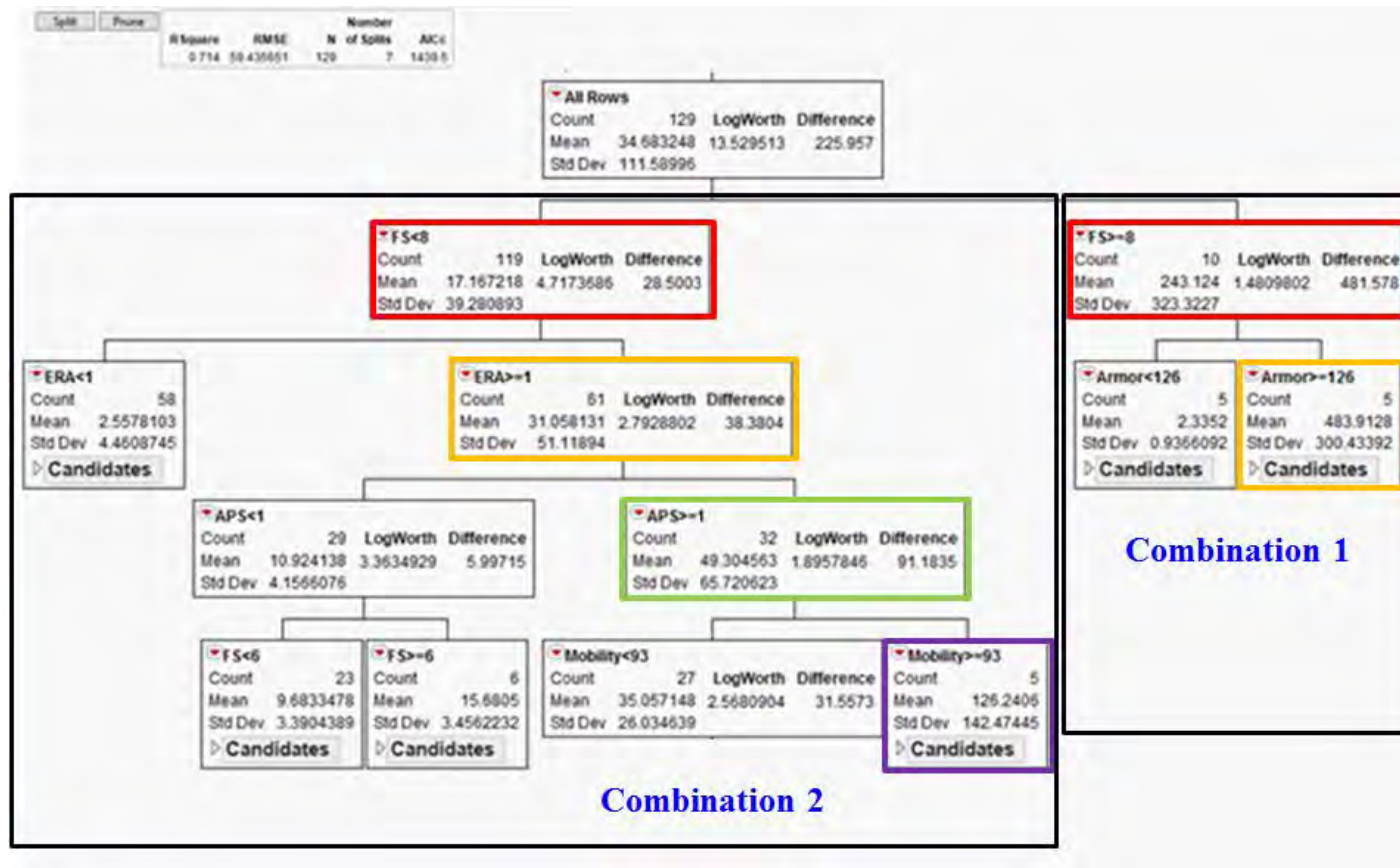

Figure 51. Partition tree analysis of MOE – FER.

The main insight gained from the partition tree analysis for FER is that having the heaviest force structure available, Pure MBT platoons, with armor thickness level of more than 126% of the original level, will drastically increase the FER for the BLUE force. It must be reiterated that for this particular MOE of FER, the higher the value of the mean, the more desired the outcome.

The combined defensive effects of the factors will improve the survivability of the platforms, thus allowing more platforms to participate in the combat longer and inflict more damage on the enemy, which accounts for the improvement in FER.

- (1) Combination 1 – FER  $\approx$  Mean of 483.9%

FACTORS	DESCRIPTION
Most Important	FS $\geq$ 8
2nd Most Important	Armor Thickness $\geq$ 126

Figure 52. MOE #2 factors of combination of choice – Combination 1.

Combination 1, as illustrated in Figure 52. is again the path of choice to improve the Force Exchange Ratio (FER) of the Armored Company Team. To do so, it is of paramount importance to have the heaviest Force Structure of value 8 (3 M1A2 MBT Platoons). This will result in an expected FER of approximately 243% as illustrated in Figure 53. The heavy force structure with thicker armor and greater firepower will allow the platforms to better survive in a combat environment. Hence, more vehicles and their firepower can be brought to bear on the enemy for a longer period of time, thus increasing the number of enemy casualties inflicted and improving the FER.

<p>*FS&lt;8</p> <p>Count 119 LogWorth Difference</p> <p>Mean 17.167218 4.7173686 28.5003</p> <p>Std Dev 39.280893</p>	<p>*FS=8</p> <p>Count 10 LogWorth Difference</p> <p>Mean 243.124 1.4809802 481.578</p> <p>Std Dev 323.3227</p>
---	--

Figure 53. Combination 1 – Comparison of outcome of MOE #2 with the difference in Force Structure.

In addition, equipping the ground platforms with passive armor that is approximately 126% as thick as that of the current armor mounted on the armored vehicle will further bolster the FER outcome to approximately 484% as illustrated in Figure 54.

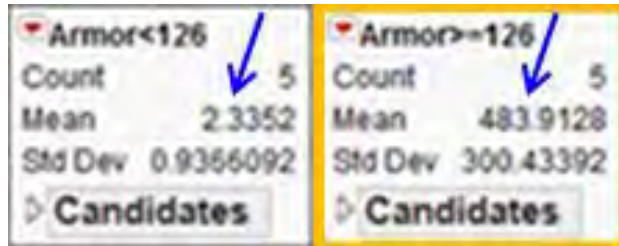

Figure 54. Combination 1 – Comparison of outcome of MOE #2 with the difference in Armor Thickness percentage.

(2) Combination 2 – FER  $\approx$  Mean of 126.24%

For any force structure configuration that is lighter than value 8, the expected FER dwindles to approximately 17.16% as illustrated in Figure 53. Hence, the presence of ERA is paramount in improving the FER, resulting in the FER increasing to approximately 31.06%. The concurrent deployment of the APS will augment the effect of the ERA and further improve the FER to approximately 49.3% as shown in Figure 55.

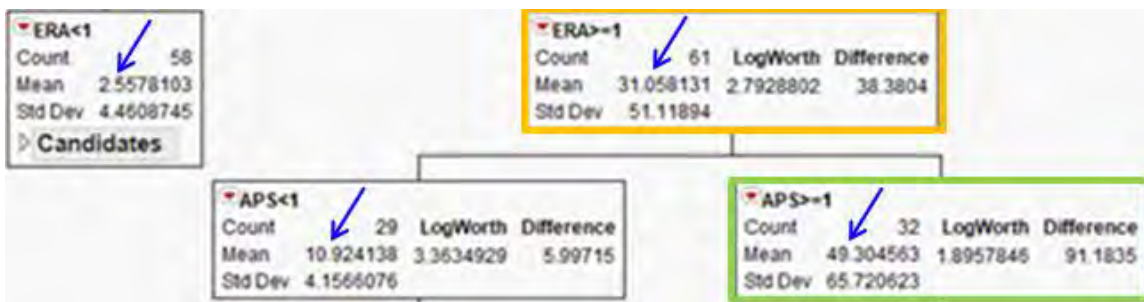

Figure 55. Combination 2 – Comparison of outcome of MOE #2 with the presence and absence of Explosive Reactive Armor and Active Protection System.

Furthermore, to improve the FER to approximately 126.24%, the mobility of the platforms must be maintained at a minimum of 93% of its original capacity after the

installation of ERA and APS. Failing to do so will render the FER to decrease to approximately 35.06% as illustrated in Figure 56.

Mobility<93				Mobility>=93			
Count	27	LogWorth	Difference	Count	5		
Mean	35.057148	2.5680904	31.5573	Mean	126.2406		
Std Dev	26.034639			Std Dev	142.47445		
				Candidates			

Figure 56. Combination 2 – Comparison of outcome of MOE #2 with the difference in Mobility percentage.

This is important as mobility is perceived as a passive defensive measure as discussed previously. Having a high mobility would improve the survivability of the platforms by improving their susceptibility as it is increasingly difficult for the enemy to track, engage, and hit the faster moving platforms. This, in turn, allows more vehicles and their firepower to be used against the enemy and increases the FER.

c. *Probability of Completing Mission Insights*

The partition tree analysis for the MOE, Probability of Completing Mission, is illustrated in Figure 57.

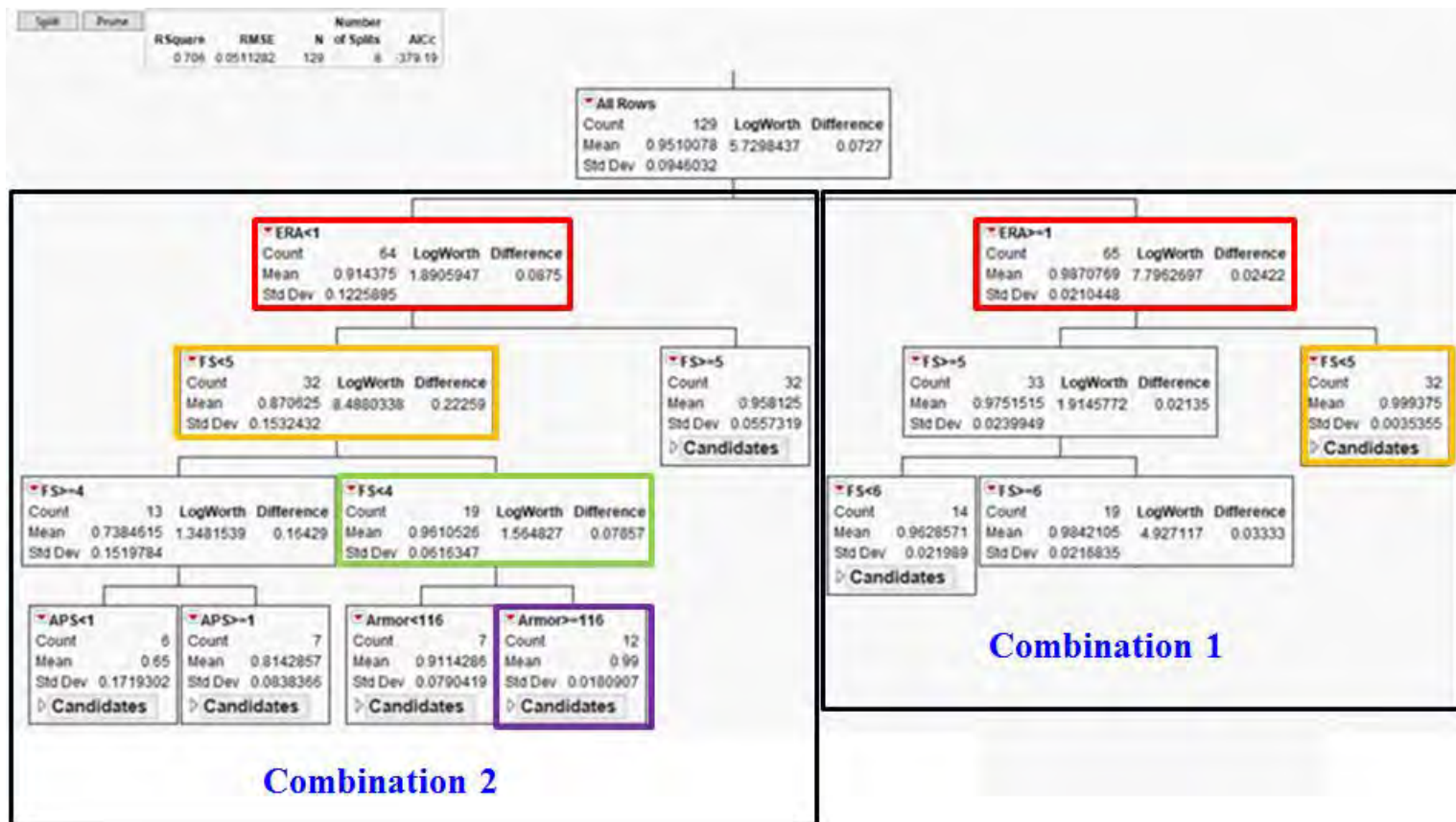

Figure 57. Partition tree analysis of MOE – Probability of Completing Mission.

The main insight gained from the partition tree analysis for the MOE #3, Probability of Completing Mission, is that having the presence of ERA is of utmost importance in determining the outcome of the MOE. Again, the larger the numerical value of the MOE output, the better.

The combined defensive effects of the factors will improve the survivability of the platforms, allowing more platforms to remain in combat longer and inflicting more damage on the enemy, which will improve the probability of the BLUE forces completing their mission.

(1) Combination 1 – Probability of Completing Mission  $\approx$  Mean of 0.999

Combination 1, as illustrated in Figure 58. is the path of choice in maximizing the outcome of this MOE. As observed, having the presence of the ERA installed on ground platforms is important to the outcome of the MOE, achieving a probability of approximately 0.987.

FACTORS	DESCRIPTION
Most Important	ERA $\geq$ 1 (Present)
2nd Most Important	FS < 5

Figure 58. MOE #3 factors of combination of choice – Combination 1.

The absence of ERA will decrease the outcome of the MOE to approximately 0.914 as illustrated in Figure 59. The defensive attributes of the ERA will improve the survivability of the platforms in a combat environment, giving the platforms more opportunities to complete its mission.

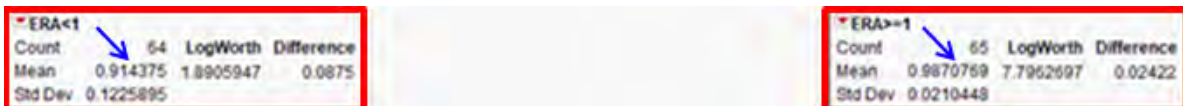

Figure 59. Combination 1 – Comparison of outcome of MOE #3 with the presence and absence of Explosive Reactive Armor.

Having a lighter force structure of a value less than 5 (1 MBT platoon and 2 Bradley platoons), will counterintuitively improve the probability of the BLUE forces completing their mission, and the probability achieved is 0.999 as compared to the heavier force structure, which gives the outcome of the MOE at approximately 0.975. These observations are illustrated in Figure 60. This is attributed to the fact that one of the criteria of mission success is defined as the capture of the two land links over the river so as to isolate and cut off the enemy defending the objective, catalyzing the collapse of the defenses.

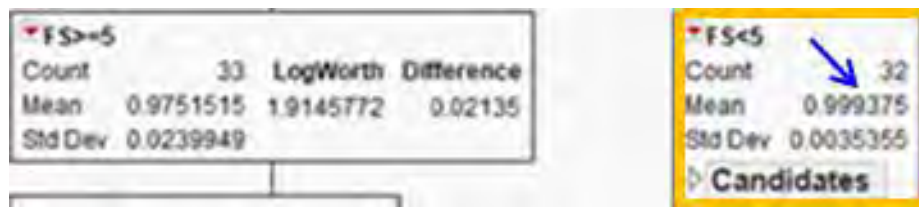

Figure 60. Combination 1 – Comparison of outcome of MOE #3 with the difference in Force Structure.

The lighter force structure, along with better mobility, will allow more platforms to reach the land links faster. In addition, the defensive attributes accorded to the platforms by having a lighter force structure with better mobility, as discussed previously, will improve the survivability of the platforms as it renders the enemy more inept at targeting, engaging, and hitting the vehicles. This allows more vehicles and their associated combat power to remain in the battle and improves the probability of them achieving their mission.

(2) Combination 2 – Probability of Completing Mission  $\approx$  Mean of 0.99

The absence of ERA will lower the probability of the BLUE forces completing their mission to approximately 0.914 due to the lack of the defensive attributes afforded by the ERA. Task organizing the Armored Company Team with a lighter force structure of less than value 4 (3 Bradley Platoons) will increase the outcome of the MOE to approximately 0.96 as illustrated in Figure 61. Figure 61. The benefits and effects of having a lighter force structure are discussed in Combination 1.

FS>=4				FS<4			
Count	13	LogWorth	Difference	Count	19	LogWorth	Difference
Mean	0.7384615	1.3481539	0.16429	Mean	0.9610526	1.564827	0.07857
Std Dev	0.1519784			Std Dev	0.0616347		

Figure 61. Combination 2 – Comparison of outcome of MOE #3 with the difference in Force Structure.

In addition, equipping the ground platforms with passive armor that is approximately 116% as thick as that of the current armor mounted on vehicles will further improve the probability of the Armored Company Team achieving the mission to approximately 0.99 as illustrated in Figure 62. The attributes and benefits of having thicker armor are discussed in previous sections.

Armor<116		Armor>=116	
Count	7	Count	12
Mean	0.9114286	Mean	0.99
Std Dev	0.0790419	Std Dev	0.0180907
Candidates		Candidates	

Figure 62. Combination 2 – Comparison of outcome of MOE #3 with the difference in Armor Thickness percentage.

d. *Time Steps Taken to Complete Mission Insights*

The partition tree analysis for the MOE, Time Steps taken to Complete Mission, is illustrated in Figure 63.

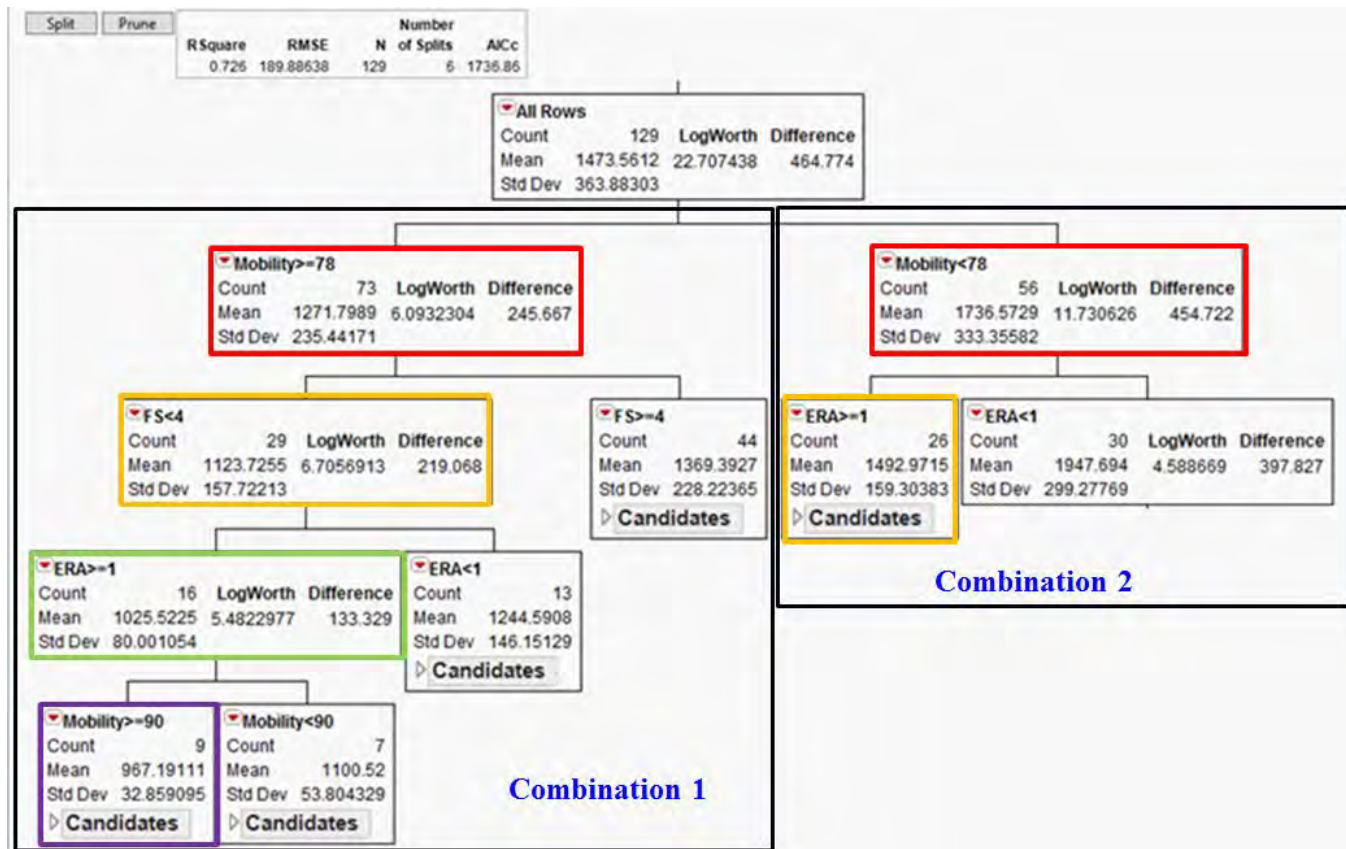

Figure 63. Partition tree analysis of MOE – Time steps taken to Complete Mission.

The main insight gleaned from this partition tree analysis is that Mobility is the paramount factor in reducing the time required to complete a mission. Having a mobility level of at least 78% of a platform’s original mobility, the time required to complete a mission would be reduced significantly by approximately 465 time steps, which is almost equivalent to a 25% reduction in mission length. For this MOE, the lower the numerical value of the outcome, the better it is.

(1) Combination 1 – Time Steps taken to Complete Mission  $\approx$  Mean of 967

For Combination 1, as illustrated in Figure 64. the combination of choice, having a mobility of at least 78% of the original value of the platform, will yield an approximate time steps required to complete mission of 1,271.

FACTORS	DESCRIPTION
Most Important	Mobility $\geq$ 78
2nd Most Important	FS < 4
3rd Most Important	ERA $\geq$ 1 (Present)
4th Most Important	Mobility $\geq$ 90

Figure 64. MOE #4 factors of combination of choice – Combination 1

Failing that, the approximate time steps required would increase to approximately 1,736 as illustrated in Figure 65. Figure 65. The benefit of having high mobility is apparent where the platforms are able to reach and capture the two land links over the river at the western edge of the objective, which constitutes mission success.

<p>▼ Mobility <math>\geq</math> 78</p> <p>Count 73 LogWorth Difference</p> <p>Mean 1271.7989 6.0932304 245.667</p> <p>Std Dev 235.44171</p>	<p>▼ Mobility &lt; 78</p> <p>Count 56 LogWorth Difference</p> <p>Mean 1736.5729 11.730626 454.722</p> <p>Std Dev 333.35582</p>
---	--

Figure 65. Combination 1 – Comparison of outcome of MOE #4 with the difference in Mobility percentage.

Having a lighter force structure of less than value 4 (3 Bradley Platoons) will further reduce the time steps taken to approximately 1,123 as observed in Figure 66. The benefits of having a light force structure were discussed in the previous sections.



Figure 66. Combination 1 – Comparison of outcome of MOE #4 with the difference in Force Structure.

Having ERA installed in the platforms will improve the time taken to approximately 1,025 and not having ERA installed will increase the time taken to approximately 1,244 time steps as observed in Figure 67. This is attributed to the improved survivability of the platforms due to the presence of the defensive attributes provided by the ERA. More platforms are able to remain in combat and bring their firepower to bear on the enemy. Hence, the increase in the number of BLUE combatants and their firepower will increase the probability of the BLUE forces capturing the land links or annihilating the enemy defenders, which is another measure of mission success.



Figure 67. Combination 1 – Comparison of outcome of MOE #4 with the presence and absence of Explosive Reactive Armor.

Finally, it can be observed in Figure 68. Figure 68. that having a mobility that is equal to or more than 90% of the platform's original value will improve the time taken for the BLUE forces to complete their mission to approximately 967 time steps.



Figure 68. Combination 1 – Comparison of outcome of MOE #4 with the difference in Mobility percentage.

(2) Combination 2 – Time Steps taken to Complete Mission  $\approx$  Mean of 1492

For Combination 2, having mobility of less than 78% of the platform's original value is very detrimental to the outcome of the MOE. This results in the BLUE forces requiring approximately 1,736 time steps to complete the mission, which is much longer than that of Combination 1 (1,271 time steps).

Having ERA installed in the platforms will improve the outcome of the number of time steps taken to complete mission marginally to approximately 1,492 steps as illustrated in Figure 69. The benefits of having ERA were discussed in the preceding section. However, with mobility, nothing further can be done to improve the time steps taken to complete the mission. This is attributed to the fact that platforms with lower mobility have less passive defense, and are more likely to be targeted, engaged, and hit by the enemy, rendering the BLUE forces with less combat power in the battle, resulting in the Armored Company Team taking a much longer time to complete its mission.

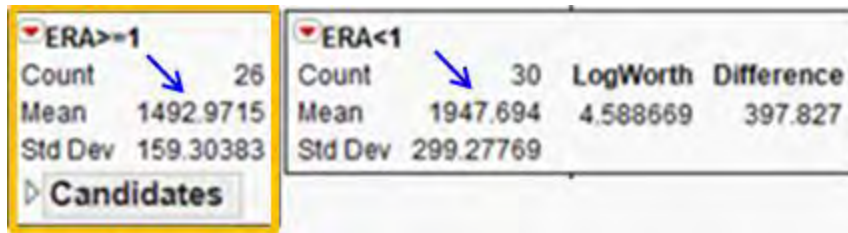

Figure 69. Combination 2 – Comparison of outcome of MOE #4 with the presence and absence of Explosive Reactive Armor.

*e. Insights Summary*

The insights gleaned from and the importance of the various factors for the four respective MOEs are summarized in Table 9. This serves to provide a quick visual guide and reference for military commanders and planners on the investment of their resources, as well as the expected outcomes of any military operations.

It can be concluded that different MOEs would have a correspondingly different set and hierarchy of factors that are important to their outcome. Hence, the military commander and planner must be prudent and cognizant of the factors and MOEs that they are interested in.

For example, when the military commander is focused on the expected casualties that will be sustained in a combat operation, the most important factor to allocate resources to in order to reduce the number of casualties would be the installation of ERA on the ground platforms involved. After which, the next important area to invest resources in would be the installation of APS on all the ground platforms.

The allocation of resources to improve the outcome of the respective MOEs of interest can be ascertained likewise.

Table 9. Summary of the importance of the factors and their threshold values on the MOEs.

		MOES			
		% BLUE Casualties	FER	Prob of Completing Mission	Time Steps taken to Complete Mission
<b>FACTORS &amp; THRESHOLD VALUES</b>	Most Important	Presence of ERA	Force Structure Value $\geq 8$ (3 MBT Platoons)	Presence of ERA	Mobility $\geq 78\%$ of Original
	2nd Most Important	Presence of APS	Armor Thickness % $\geq 126$	Force Structure Value $< 5$ (1 MBT Platoon + 2 Bradley Platoons)	Force Structure Value $< 4$ (3 Bradley Platoons)
	3rd Most Important				Presence of ERA
	4th Most Important				Mobility $\geq 90\%$ of Original

= Most Important Factor
  = 2<sup>nd</sup> Most Important Factor
  = 3<sup>rd</sup> Most Important Factor
  = 4<sup>th</sup> Most Important Factor

THIS PAGE INTENTIONALLY LEFT BLANK

## VII. CONCLUSION

The inadequacy of traditional passive armor alone to improve survivability for armored vehicles, which indirectly leads to the inability of the armored force to accomplish its mission, is getting more and more evident, especially with the rapid evolution of threats and the mission sets required of the Armored Company Team, such as an offensive operation to capture an urban objective.

### A. SUMMARY AND CONCLUSIONS

At the conclusion of the study, the following research questions that focused and directed the study were adequately addressed.

1. What are the primary design factors for a ground combat vehicle in order to achieve mission success and survivability in offensive operations in an urban environment?

As evidenced in the study, a myriad of asymmetric means to improve the survivability of the ground platforms in an urban environment were explored and the factors that are important were determined through this study. It is recommended for future military planners to invest resources into improving these attributes of an armored vehicle. The factors are:

- Passive Armor Thickness Percentage
  - Presence of Explosive Reactive Armor
  - Presence of Active Protection System
  - Mobility Percentage
  - Force Structure
2. How does the tradeoff of one parameter affect the platform's survivability and performance as a whole?

The tradeoff of design parameters and the corresponding effects on the platform's survivability are determined from the study. The armor thickness and the presence of ERA on the armored vehicle have the largest effect on the number of casualties sustained

by the BLUE forces. When the force exchange ratio is of concern, the factors that have the largest effect are the armor thickness of the armored vehicle and the force structure of the armored company team.

In addition, the presence of ERA on the armored vehicle and the mobility of the armored vehicle have the largest impact on the probability of the BLUE forces completing its mission and the time taken for the BLUE forces to accomplish their mission.

3. What is the relative importance of attributes on the platform?

The importance of attributes is different based on the MOE of interest listed for the following MOEs:

- Percentage of BLUE Casualties

In order of descending priority, the important attributes are having the presence of ERA and APS installed.

- Force Exchange Ratio

In order of descending priority, the important attributes are having the force structure of three MBT platoons and having an armor thickness of at least 126% for each platform.

- Probability of Completing Mission

In order of descending priority, the important attributes are having the presence of ERA and having a force structure that is heavier than the force structure of one MBT platoon and two Bradley platoons.

- Time Steps taken to Complete Mission

In order of descending priority, the important attributes are having a mobility of more than 70%, a force structure that is equivalent or heavier than three Bradley platoons, having ERA installed on all platforms and having a mobility of more than 90%.

Leveraging on the analysis of the simulation results, equations based on regression models from the simulation were obtained for the identified MOEs.

The benefits of the MOE equations lie in the fact that they allow the military commanders and planners to have some insight into the outcome of any military operations that they are required to undertake. In addition, the equations may help them to prioritize and invest resources in order to achieve certain levels of desired outcomes in any MOEs.

Upon more in-depth analysis, a partition tree was created using the results for the factors where their relative importance and respective threshold values were determined. These findings are important as they allow the military planners and commanders to prioritize their limited resources according to the factor of paramount importance when addressing the respective MOEs. In layman terms, it is a comprehensive guide for military commanders on the allocation of their resources.

In addition, these findings will be of long-term influence in the armored vehicle community where the design of the next-generation armored vehicles will take place. They will provide insight and guidance to the designers on areas and factors to focus on while designing the vehicles and platforms for survivability.

## **B. FUTURE WORK**

This study, though extensive, is by no means complete. It is the opinion and recommendation of the author that the following areas would require further research and study.

### **(1) Survivability of Armored Vehicles in Different Environments and Operations**

As this study focused solely on the offensive operations of an Armored Company Team in an urban environment, there is much scope for the further research and exploration of different sized forces of armored platforms performing other operations, such as defensive and stability operations, in other environments.

## (2) More Intensive Research

The space filling property of the NOLH was being leveraged in this study. It is opined that a full factorial design can be performed to generate a larger and more extensive number of sets of design points. This will serve to further refine and validate the findings in this paper.

In addition, the simulation software of choice in this research was MANA. Further research can be done using established combat simulation software, such as COMBAT XXI, to further research and validate the presented findings.

## (3) The Effect and Interaction of Armor Thickness with Presence of ERA and Presence of ERA with Presence of APS

The author highlighted in earlier chapters that there was a contradiction in the observed results from the interaction of these factors: Armor Thickness Percentage with the Presence of ERA and the Presence of ERA with Presence of APS. Hence, more research and study would be required to establish the interactions and effects of the two factors on the respective MOEs.

## (4) Using Actual Values for Simulations

As this research is unclassified, much of the values used as inputs in the simulations, such as Armor Thickness and Armor Penetration Capability of the platform's weapons, are derived from open sources which are likely to deviate from the true value. Hence, more accurate and realistic results can be obtained if the actual values of the platforms' various attributes can be used for further research.

THIS PAGE INTENTIONALLY LEFT BLANK

## APPENDIX A. MODEL PARAMETERS

Table 10 illustrates the values used for the units' attributes in the MANA simulation.

Table 10. MANA input parameters.

	Class	Agent Class	Type	Threat Level	Weight (ton)	Patrol Speed (mph)	Max Speed (mph)	Inherent Armor Thickness - KE (mm of RHA)	Inherent Armor Thickness - CE (mm of RHA)	Inherent Armour Thickness (mm of RHA)	No. of Hits to Kill	Weapon Type	Caliber (mm)	KINETIC ENERGY					CHEMICAL ENERGY					Shots / s	Slew Rate (Degrees / sec)	Sighting Detection Range (m)	Sighting Class Range (m)	Sighting Sensor FOV (degrees )											
														Quantity	Weapons Range (m)	Armour Penetration (mm RHA)	Std Dev	P(hit)	Quantity	Weapons Range (m)	Armour Penetration (mm RHA)	Std Dev	P(hit)																
AGENT	MBT	1	M1A2	3	70	25	42	960	1,620	1,000	1	Main Gun	120	27	4,000	950	150	15	2,500	750	150	10	40	8,000	4,000	8													
				T-90	3	47	20	43	920	1,340	1,000	1	Main Gun	125	25	4,000	800	150	15	2,500	600	150	10	40	8,000	4,000	7												
		AFV	2	Bradley	2	27	25	41	500	600	500	1	Canon	25	300	2,500	25	10	900	2,200	10	10	1,000	60	7,000	3,500	20												
				BMP-2	2	14	27	45	450	500	450	1	MG	7.62	2,200	1,200	10	1	-	-	-	-	-	50	4,000	2,500	15												
		IFV	3	Stryker	2	16.5	37	62	250	350	250	1	HMG	12.7	2,200	2,000	20	4	-	-	-	-	-	1,000	60	5,000	2,500	25											
	40mm AGL												40	-	-	-	-	-	462	1,400	0	0	300																
		Technical	5	50 Cal	1	1.5	20	60	-	-	0	1	HMG	12.7	300	2,000	20	4	-	-	-	-	1,000	-	-	3,000	3,000	180											
		Technical	5	ATGM	1	1.5	20	60	-	-	0	1	MILAN	-	-	-	-	-	2	3,000	1,050	160	-	-	4,000	3,500	90												
		Technical	5	RPG-29	1	1.5	20	60	-	-	0	1	RPG-29	105	-	-	-	-	-	500	850	200	-	-	3,000	3,000	180												
		En Troops	4	50 Cal	1	-	2	4	-	-	0	1	HMG	12.7	300	2,000	20	4	-	-	-	-	1,000	-	-	3,000	3,000	180											
		En Troops	4	ATGM	1	-	2	4	-	-	0	1	MILAN	-	-	-	-	-	2	3,000	1,050	160	-	-	4,000	3,500	90												
	En Troops	4	RPG-29	1	-	2	4	-	-	0	1	RPG-29	105	-	-	-	-	2	500	850	200	3	-	3,000	3,000	180													
	AT Mine	6	TM 83	2	-	-	-	-	-	0	1	TM 83	-	-	-	-	-	1	50	950	100	-	-	50	50	20													
	UAV	7	RQ 11 Raven	1	-	-	56	-	-	0	1	-	-	-	-	-	-	-	-	-	-	180	10,000	10,000	360														
	AH	8	AH-64D	3	-	-	183	-	-	0	5	Hellfire	-	-	-	-	-	8	8,000	1,200	120	-	10	180	8,000	7,000	20												

THIS PAGE INTENTIONALLY LEFT BLANK

## APPENDIX B. DESIGN OF EXPERIMENTS AND SIMULATION RESULTS

This section tabulates the design points generated for both the initial and refined simulations with their corresponding results.

### A. INITIAL SIMULATION DESIGN POINTS GENERATED USING MINITAB AND SIMULATION RESULTS

Table 12. Table 13. Table 14. and Table 14. tabulates the results for the respective MOEs for each design point.

Table 11. Initial DOE and results – Part 1.

RUN	Armor Thickness (100% to 140%)	APS (Yes - Hit Prob Lowered) (50%)	ERA (Yes - Increase No. of Hits to Kill) (1 to 3)	Mobility (100% to 60%)	Signature Management (0% to 30%)	Additional Sensor (UAV)	Force Structure (Pure MBT vs Pure Stryker)	BLUE Casualties	SE	Percentage Casualties	RED Casualties	SE	FER (BLUE / RED)	BLUE Goal	SE	Time to Complete Mission	SE
1	140	No	No	100	Yes	No	Pure MBT	0.1	0.042857	0.008333333	25.44	0.399142	0.003931	0.86	0.04957	1406.22	9.371746
2	140	No	No	100	No	No	Pure MBT	0.2	0.063888	0.016666667	25.54	0.398169	0.007831	0.86	0.04957	1413.52	9.68998
3	100	No	No	60	Yes	No	Pure MBT	7.16	0.333638	0.596666667	21.62	0.535202	0.331175	0.68	0.066639	2709.7	32.70527
4	100	No	No	100	Yes	No	Pure MBT	5.88	0.315116	0.49	22.88	0.510014	0.256993	0.9	0.042857	1589.6	60.65591
5	100	No	No	100	No	No	Pure MBT	5.94	0.310904	0.495	22.68	0.565281	0.261905	0.92	0.038756	1569.62	53.17319
6	140	No	No	60	No	No	Pure MBT	0.26	0.068868	0.021666667	26.6	0.354562	0.009774	0.82	0.054884	2403.16	21.55182
7	140	No	No	60	Yes	No	Pure MBT	0.22	0.065714	0.018333333	26.3	0.370603	0.008365	0.86	0.04957	2447.1	20.86321
8	100	No	No	60	No	No	Pure MBT	7.44	0.322186	0.62	21.52	0.587794	0.345725	0.56	0.070912	2706.6	37.56202
9	140	No	Yes	100	Yes	No	Pure MBT	0	0	0	25.34	0.366573	0	0.96	0.027994	1417.82	10.29681
10	140	No	Yes	60	Yes	No	Pure MBT	0	0	0	26.2	0.379043	0	0.86	0.04957	2429.4	18.07779
11	140	No	Yes	100	No	No	Pure MBT	0	0	0	25.04	0.414985	0	0.9	0.042857	1410.88	8.954335
12	100	No	Yes	60	No	No	Pure MBT	3.16	0.381576	0.263333333	24.56	0.501557	0.128664	0.8	0.057143	2547.96	30.26791
13	100	No	Yes	100	No	No	Pure MBT	1.36	0.231693	0.113333333	24.5	0.411319	0.05551	0.98	0.02	1439	8.772824
14	100	No	Yes	100	Yes	No	Pure MBT	1.18	0.205416	0.098333333	24.92	0.371253	0.047352	1	0	1447.34	9.423402
15	140	No	Yes	60	No	No	Pure MBT	0	0	0	25.7	0.416251	0	0.88	0.046423	2428.12	16.48385
16	100	No	Yes	60	Yes	No	Pure MBT	2.68	0.35044	0.223333333	25.88	0.43013	0.103555	0.78	0.059178	2440.44	26.95039
17	140	No	No	60	No	Yes	Pure MBT	0.2	0.075593	0.016666667	25.82	0.347222	0.007746	0.86	0.04957	2438.9	19.36994
18	140	No	No	100	Yes	Yes	Pure MBT	0.2	0.057143	0.016666667	25.16	0.383709	0.007949	0.94	0.033927	1413.2	8.410149
19	100	No	No	100	Yes	Yes	Pure MBT	6.14	0.355723	0.511666667	22.5	0.546043	0.272889	0.84	0.052372	1714.98	79.69816
20	140	No	No	100	No	Yes	Pure MBT	0.22	0.065714	0.018333333	25.34	0.385036	0.008682	0.94	0.033927	1414.46	9.509961

Table 12. Initial DOE and results – Part 2.

RUN	Armor Thickness (100% to 140%)	APS (Yes - Hit Prob Lowered) (50%)	ERA (Yes - Increase No. of Hits to Kill) (1 to 3)	Mobility (100% to 60%)	Signature Management (0% to 30%)	Additional Sensor (UAV)	Force Structure (Pure MBT vs Pure Stryker)	BLUE Casualties	SE	Percentage Casualties	RED Casualties	SE	FER (BLUE / RED)	BLUE Goal	SE	Time to Complete Mission	SE
21	100	No	No	60	Yes	Yes	Pure MBT	7.06	0.290545	0.588333333	22.14	0.675525	0.31888	0.64	0.068571	2682.34	35.91209
22	140	No	No	60	Yes	Yes	Pure MBT	0.3	0.076931	0.025	25.98	0.36866	0.011547	0.9	0.042857	2454.2	15.807
23	100	No	No	100	No	Yes	Pure MBT	6.44	0.332167	0.536666667	21.42	0.610848	0.300654	0.82	0.054884	1658.88	72.14243
24	100	No	No	60	No	Yes	Pure MBT	7.36	0.320408	0.613333333	21.06	0.66909	0.349478	0.6	0.069985	2738.48	35.41086
25	100	No	Yes	60	No	Yes	Pure MBT	3.62	0.410962	0.301666667	25.04	0.48652	0.144569	0.78	0.059178	2514.2	32.30832
26	140	No	Yes	60	No	Yes	Pure MBT	0	0	0	25.94	0.398374	0	0.88	0.046423	2411.72	21.52229
27	140	No	Yes	100	No	Yes	Pure MBT	0	0	0	24.88	0.379731	0	0.96	0.027994	1432.44	9.680283
28	100	No	Yes	100	Yes	Yes	Pure MBT	1.06	0.208806	0.088333333	25.18	0.394544	0.042097	0.92	0.038756	1429.12	8.027231
29	140	No	Yes	60	Yes	Yes	Pure MBT	0	0	0	25.9	0.407331	0	0.9	0.042857	2409	21.57292
30	100	No	Yes	60	Yes	Yes	Pure MBT	2.54	0.334676	0.211666667	25.24	0.396474	0.100634	0.9	0.042857	2541.16	23.32159
31	100	No	Yes	100	No	Yes	Pure MBT	1.08	0.189177	0.09	24.68	0.413487	0.04376	0.96	0.027994	1427.04	11.21828
32	140	No	Yes	100	Yes	Yes	Pure MBT	0	0	0	25.02	0.403546	0	0.98	0.02	1416.78	7.56222
33	100	Yes	No	60	No	No	Pure MBT	5.76	0.28365	0.48	22.62	0.57845	0.254642	0.82	0.054884	2579.06	30.08607
34	140	Yes	No	100	Yes	No	Pure MBT	0.04	0.027994	0.003333333	25.68	0.36971	0.001558	0.94	0.033927	1439.68	7.828594
35	140	Yes	No	100	No	No	Pure MBT	0.08	0.038756	0.006666667	25.26	0.440603	0.003167	0.92	0.038756	1443.6	7.477422
36	140	Yes	No	60	No	No	Pure MBT	0.12	0.054511	0.01	26.12	0.421504	0.004594	0.84	0.052372	2444.32	19.80926
37	100	Yes	No	100	No	No	Pure MBT	5.08	0.361222	0.423333333	22.92	0.5189	0.22164	0.9	0.042857	1600.12	59.99059
38	100	Yes	No	100	Yes	No	Pure MBT	4.94	0.308267	0.411666667	23.38	0.481401	0.211292	0.94	0.033927	1540.82	44.47007
39	140	Yes	No	60	Yes	No	Pure MBT	0.14	0.063952	0.011666667	25.7	0.424985	0.005447	0.9	0.042857	2468.56	18.50651
40	100	Yes	No	60	Yes	No	Pure MBT	5.68	0.340995	0.473333333	22.42	0.630575	0.253345	0.58	0.070508	2642.24	39.08436
41	140	Yes	Yes	100	No	No	Pure MBT	0	0	0	21.78	0.474053	0	1	0	1216.88	9.412482
42	140	Yes	Yes	60	No	No	Pure MBT	0	0	0	24.26	0.400826	0	0.98	0.02	2158.76	29.03342
43	100	Yes	Yes	60	No	No	Pure MBT	0.78	0.118804	0.065	23	0.432364	0.033913	1	0	2143.66	21.79001
44	140	Yes	Yes	100	Yes	No	Pure MBT	0	0	0	23.54	0.432562	0	0.98	0.02	1250.82	10.28336
45	100	Yes	Yes	100	No	No	Pure MBT	0.2	0.075593	0.016666667	22.14	0.472086	0.009033	0.98	0.02	1236.38	10.45374
46	100	Yes	Yes	100	Yes	No	Pure MBT	0.12	0.046423	0.01	22.92	0.504543	0.005236	0.98	0.02	1256.88	9.652266
47	140	Yes	Yes	60	Yes	No	Pure MBT	0	0	0	23.86	0.419922	0	0.98	0.02	2136	23.20574
48	100	Yes	Yes	60	Yes	No	Pure MBT	0.58	0.151429	0.048333333	25.48	0.425935	0.022763	0.92	0.038756	2181.14	24.92523
49	140	Yes	No	60	No	Yes	Pure MBT	0.32	0.072506	0.026666667	24.46	0.479974	0.013083	0.96	0.027994	2185.76	22.58923
50	140	Yes	No	100	No	Yes	Pure MBT	0.14	0.04957	0.011666667	22.36	0.430244	0.006261	0.98	0.02	1238.62	7.321586
51	140	Yes	No	100	Yes	Yes	Pure MBT	0.06	0.033927	0.005	22.86	0.441713	0.002625	0.96	0.027994	1233.08	8.530897
52	100	Yes	No	60	Yes	Yes	Pure MBT	5.1	0.360555	0.425	23.06	0.538638	0.221162	0.86	0.04957	2390.36	38.32174
53	140	Yes	No	60	Yes	Yes	Pure MBT	0.1	0.042857	0.008333333	24.6	0.486554	0.004065	0.92	0.038756	2177.3	23.80959
54	100	Yes	No	60	No	Yes	Pure MBT	5.3	0.326077	0.441666667	21.68	0.587933	0.244465	0.86	0.04957	2360.76	44.92104
55	100	Yes	No	100	No	Yes	Pure MBT	4.28	0.237401	0.356666667	21.6	0.627271	0.198148	0.94	0.033927	1291.32	12.86373
56	100	Yes	No	100	Yes	Yes	Pure MBT	3.26	0.320472	0.271666667	21.32	0.558014	0.152908	0.96	0.027994	1322.76	50.17358
57	100	Yes	Yes	100	Yes	Yes	Pure MBT	0.2	0.057143	0.016666667	22.74	0.538183	0.008795	0.98	0.02	1238.7	10.37467
58	140	Yes	Yes	60	No	Yes	Pure MBT	0	0	0	24.28	0.432402	0	0.94	0.033927	2134.74	23.42048
59	140	Yes	Yes	100	Yes	Yes	Pure MBT	0	0	0	22.78	0.493459	0	0.96	0.027994	1250.1	8.845395
60	100	Yes	Yes	100	No	Yes	Pure MBT	0.28	0.070218	0.023333333	22.16	0.499273	0.012635	1	0	1234.7	10.09604

Table 13. Initial DOE and results – Part 3.

RUN	Armor Thickness (100% to 140%)	APS (Yes - Hit Prob Lowered) (50%)	ERA (Yes - Increase No. of Hits to Kill) (1 to 3)	Mobility (100% to 60%)	Signature Management (0% to 30%)	Additional Sensor (UAV)	Force Structure (Pure MBT vs Pure Stryker)	BLUE Casualties	SE	Percentage Casualties	RED Casualties	SE	FER (BLUE / RED)	BLUE Goal	SE	Time to Complete Mission	SE
61	100	Yes	Yes	60	Yes	Yes	Pure MBT	0.66	0.129709	0.055	24.82	0.424447	0.026591	0.92	0.038756	2213.06	24.06183
62	100	Yes	Yes	60	No	Yes	Pure MBT	0.74	0.117143	0.061666667	24.26	0.383124	0.030503	0.92	0.038756	2170.66	25.29368
63	140	Yes	Yes	100	No	Yes	Pure MBT	0	0	0	22.8	0.463351	0	0.98	0.02	1241.72	10.37635
64	140	Yes	Yes	60	Yes	Yes	Pure MBT	0	0	0	24.7	0.386771	0	0.96	0.027994	2195.74	23.90932
65	140	No	No	60	No	No	Stryker + 1 MBT Platoon	3.62	0.242251	0.362	21.66	0.549293	0.167128	0.68	0.066639	2262.02	81.82124
66	100	No	No	100	No	No	Stryker + 1 MBT Platoon	6.32	0.273212	0.632	17.66	0.675284	0.357871	0.82	0.054884	1513.24	101.6306
67	140	No	No	100	Yes	No	Stryker + 1 MBT Platoon	2.94	0.192534	0.294	20.46	0.543766	0.143695	0.98	0.02	1121.42	21.18328
68	100	No	No	100	Yes	No	Stryker + 1 MBT Platoon	5.88	0.272014	0.588	18.58	0.591843	0.316469	0.9	0.042857	1380.4	81.05261
69	140	No	No	60	Yes	No	Stryker + 1 MBT Platoon	3.64	0.224536	0.364	22.1	0.472294	0.164706	0.74	0.062662	2210.1	76.72346
70	140	No	No	100	No	No	Stryker + 1 MBT Platoon	3.74	0.180272	0.374	20.44	0.491694	0.182975	1	0	1161.4	22.90033
71	100	No	No	60	No	No	Stryker + 1 MBT Platoon	6.46	0.318427	0.646	18.28	0.725647	0.353392	0.52	0.071371	2353.42	91.59878
72	100	No	No	60	Yes	No	Stryker + 1 MBT Platoon	6.42	0.269679	0.642	18.9	0.681086	0.339683	0.54	0.0712	2344.8	89.82637
73	140	No	Yes	60	No	No	Stryker + 1 MBT Platoon	0.64	0.120407	0.064	22.98	0.551429	0.02785	0.92	0.038756	1666.74	28.66365
74	100	No	Yes	100	Yes	No	Stryker + 1 MBT Platoon	0.64	0.14217	0.064	21.44	0.526955	0.029851	0.98	0.02	1026.36	18.39716
75	140	No	Yes	100	Yes	No	Stryker + 1 MBT Platoon	0.28	0.075809	0.028	20.88	0.50276	0.01341	1	0	970.68	11.12524
76	140	No	Yes	60	Yes	No	Stryker + 1 MBT Platoon	0.7	0.134771	0.07	20.98	0.524105	0.033365	0.96	0.027994	1632.26	36.93647
77	100	No	Yes	60	No	No	Stryker + 1 MBT Platoon	1.02	0.17021	0.102	21.86	0.533766	0.046661	0.98	0.02	1613.22	26.45667
78	100	No	Yes	100	No	No	Stryker + 1 MBT Platoon	0.66	0.126523	0.066	20.68	0.475901	0.031915	1	0	1001.52	13.57541
79	140	No	Yes	100	No	No	Stryker + 1 MBT Platoon	0.32	0.092317	0.032	21.4	0.518239	0.014953	0.98	0.02	1006.76	14.07443
80	100	No	Yes	60	Yes	No	Stryker + 1 MBT Platoon	0.76	0.141594	0.076	22.12	0.405714	0.034358	0.98	0.02	1626.32	37.09008
81	100	No	No	60	No	Yes	Stryker + 1 MBT Platoon	6.08	0.296703	0.608	17.54	0.613594	0.346636	0.64	0.068571	2205.84	89.433
82	100	No	No	60	Yes	Yes	Stryker + 1 MBT Platoon	6.2	0.27701	0.62	18.78	0.623545	0.330138	0.5	0.071429	2369.02	92.10178
83	140	No	No	100	Yes	Yes	Stryker + 1 MBT Platoon	2.96	0.211814	0.296	21.86	0.589022	0.135407	0.96	0.027994	1190.64	41.65915
84	100	No	No	100	Yes	Yes	Stryker + 1 MBT Platoon	5.42	0.263555	0.542	18.06	0.579521	0.300111	0.92	0.038756	1280.66	75.22752
85	140	No	No	60	No	Yes	Stryker + 1 MBT Platoon	3.64	0.189004	0.364	21.66	0.566125	0.168052	0.68	0.066639	2279.86	82.51574
86	140	No	No	60	Yes	Yes	Stryker + 1 MBT Platoon	3.38	0.24393	0.338	21.74	0.421668	0.155474	0.74	0.062662	2168.12	85.90246
87	100	No	No	100	No	Yes	Stryker + 1 MBT Platoon	5.12	0.280873	0.512	18.68	0.627558	0.27409	0.88	0.046423	1328.76	90.07126
88	140	No	No	100	No	Yes	Stryker + 1 MBT Platoon	2.9	0.183503	0.29	20.88	0.457714	0.138889	1	0	1134.96	32.15967
89	140	No	Yes	100	No	Yes	Stryker + 1 MBT Platoon	0.38	0.09852	0.038	21.12	0.550058	0.017992	0.98	0.02	1031.54	15.20428
90	100	No	Yes	100	Yes	Yes	Stryker + 1 MBT Platoon	0.66	0.123255	0.066	20.52	0.485075	0.032164	1	0	1001.34	12.65329
91	140	No	Yes	60	Yes	Yes	Stryker + 1 MBT Platoon	0.78	0.162355	0.078	21.78	0.473192	0.035813	0.96	0.027994	1624.52	40.58705
92	140	No	Yes	60	No	Yes	Stryker + 1 MBT Platoon	0.76	0.135707	0.076	21.8	0.480646	0.034862	0.96	0.027994	1658.78	34.78181
93	100	No	Yes	60	No	Yes	Stryker + 1 MBT Platoon	0.92	0.142399	0.092	21.74	0.444293	0.042318	1	0	1593.16	21.86378
94	100	No	Yes	60	Yes	Yes	Stryker + 1 MBT Platoon	0.78	0.140814	0.078	21.62	0.478851	0.036078	1	0	1625.58	24.5271
95	140	No	Yes	100	Yes	Yes	Stryker + 1 MBT Platoon	0.32	0.087785	0.032	24.72	0.406117	0.012945	0.94	0.033927	1224.16	9.965056
96	100	No	Yes	100	No	Yes	Stryker + 1 MBT Platoon	0.9	0.174379	0.09	24.5	0.486764	0.036735	0.94	0.033927	1209.08	11.36966
97	100	Yes	No	100	No	No	Stryker + 1 MBT Platoon	4.02	0.283549	0.402	21.06	0.549144	0.190883	0.98	0.02	1314.72	40.9693
98	140	Yes	No	60	Yes	No	Stryker + 1 MBT Platoon	2.06	0.200835	0.206	22.28	0.522193	0.09246	0.94	0.033927	1889.84	72.28239
99	100	Yes	No	60	Yes	No	Stryker + 1 MBT Platoon	4.46	0.280248	0.446	20.34	0.512385	0.219272	0.88	0.046423	1849.72	67.52165
100	140	Yes	No	60	No	No	Stryker + 1 MBT Platoon	1.9	0.192195	0.19	21.96	0.540567	0.086521	0.88	0.046423	1831.68	62.79948

Table 14. Initial DOE and results – Part 4.

RUN	Armor Thickness (100% to 140%)	APS (Yes - Hit Prob Lowered) (50%)	ERA (Yes - Increase No. of Hits to Kill) (1 to 3)	Mobility (100% to 60%)	Signature Management (0% to 30%)	Additional Sensor (UAV)	Force Structure (Pure MBT vs Pure Stryker)	BLUE Casualties	SE	Percentage Casualties	RED Casualties	SE	FER (BLUE / RED)	BLUE Goal	SE	Time to Complete Mission	SE
101	100	Yes	No	60	No	No	Stryker + 1 MBT Platoon	4.86	0.315595	0.486	20.76	0.691381	0.234104	0.76	0.061012	1982.88	74.41227
102	100	Yes	No	100	Yes	No	Stryker + 1 MBT Platoon	4.08	0.32051	0.408	18.88	0.552279	0.216102	0.94	0.033927	1206.82	68.47891
103	140	Yes	No	100	No	No	Stryker + 1 MBT Platoon	2	0.189521	0.2	21.48	0.612949	0.09311	0.96	0.027994	1082.86	28.72009
104	140	Yes	No	100	Yes	No	Stryker + 1 MBT Platoon	1.78	0.167308	0.178	20.18	0.483769	0.088206	1	0	1045.72	15.71761
105	140	Yes	Yes	60	Yes	No	Stryker + 1 MBT Platoon	0.12	0.054511	0.012	22.04	0.411032	0.005445	1	0	1586.48	23.15319
106	100	Yes	Yes	100	Yes	No	Stryker + 1 MBT Platoon	0.12	0.054511	0.012	20.36	0.436835	0.005894	1	0	981.5	10.77519
107	140	Yes	Yes	100	Yes	No	Stryker + 1 MBT Platoon	0.06	0.044355	0.006	20.96	0.540567	0.002863	0.98	0.02	1004.1	14.96718
108	140	Yes	Yes	60	No	No	Stryker + 1 MBT Platoon	0.16	0.072054	0.016	21.72	0.416046	0.007366	0.96	0.027994	1608.94	46.11947
109	140	Yes	Yes	100	No	No	Stryker + 1 MBT Platoon	0.06	0.044355	0.006	20.26	0.505327	0.002962	1	0	991.24	14.1423
110	100	Yes	Yes	60	Yes	No	Stryker + 1 MBT Platoon	0.2	0.063888	0.02	21.94	0.430861	0.009116	1	0	1591.18	35.13229
111	100	Yes	Yes	100	No	No	Stryker + 1 MBT Platoon	0.16	0.052372	0.016	21.28	0.502272	0.007519	1	0	1013.22	13.84849
112	100	Yes	Yes	60	No	No	Stryker + 1 MBT Platoon	0.34	0.083837	0.034	21.86	0.532234	0.015554	0.96	0.027994	1606.58	24.9897
113	100	Yes	No	60	No	Yes	Stryker + 1 MBT Platoon	4.32	0.268693	0.432	20.62	0.545026	0.209505	0.84	0.052372	1838.64	72.59878
114	100	Yes	No	100	Yes	Yes	Stryker + 1 MBT Platoon	3.08	0.264714	0.308	19.76	0.501882	0.15587	0.98	0.02	1111.12	42.78016
115	140	Yes	No	60	Yes	Yes	Stryker + 1 MBT Platoon	2.4	0.197949	0.24	22.74	0.607981	0.105541	0.86	0.04957	1928.8	68.45458
116	140	Yes	No	100	No	Yes	Stryker + 1 MBT Platoon	1.82	0.144815	0.182	21.48	0.518428	0.08473	1	0	1049.42	18.4968
117	140	Yes	No	60	No	Yes	Stryker + 1 MBT Platoon	2.24	0.179705	0.224	21.84	0.478399	0.102564	0.92	0.038756	1837.2	60.86262
118	100	Yes	No	60	Yes	Yes	Stryker + 1 MBT Platoon	4.14	0.272569	0.414	19.8	0.538327	0.209091	0.84	0.052372	1865.12	74.58502
119	100	Yes	No	100	No	Yes	Stryker + 1 MBT Platoon	4.2	0.235606	0.42	18.84	0.520878	0.22293	0.96	0.027994	1161.58	56.51317
120	140	Yes	No	100	Yes	Yes	Stryker + 1 MBT Platoon	1.84	0.181513	0.184	20.6	0.478944	0.08932	1	0	1091.7	28.05626
121	100	Yes	Yes	60	Yes	Yes	Stryker + 1 MBT Platoon	0.4	0.085714	0.04	21.72	0.509534	0.018416	0.96	0.027994	1573.04	19.4426
122	100	Yes	Yes	100	Yes	Yes	Stryker + 1 MBT Platoon	0.34	0.078818	0.034	21.06	0.53712	0.016144	0.98	0.02	1007.08	15.48155
123	100	Yes	Yes	100	No	Yes	Stryker + 1 MBT Platoon	0.14	0.04957	0.014	20.56	0.508828	0.006809	0.98	0.02	988.72	13.99895
124	140	Yes	Yes	60	Yes	Yes	Stryker + 1 MBT Platoon	0.12	0.046423	0.012	22.38	0.445284	0.005362	0.98	0.02	1601.6	21.79742
125	140	Yes	Yes	100	Yes	Yes	Stryker + 1 MBT Platoon	0.08	0.038756	0.008	20.8	0.58554	0.003846	0.96	0.027994	970.4	10.88556
126	140	Yes	Yes	100	No	Yes	Stryker + 1 MBT Platoon	0.02	0.02	0.002	20.72	0.545886	0.000965	1	0	967.98	9.867055
127	100	Yes	Yes	60	No	Yes	Stryker + 1 MBT Platoon	0.46	0.099837	0.046	21.84	0.553549	0.021062	0.96	0.027994	1608.12	24.27858
128	140	Yes	Yes	60	No	Yes	Stryker + 1 MBT Platoon	0.16	0.052372	0.016	21.66	0.476047	0.007387	1	0	1601.68	33.38343

**B. REFINED SIMULATION DESIGN POINTS GENERATED USING NOLH MINITAB AND SIMULATION RESULTS**

Table 16. Table 17. Table 18. Table 19. and Table 19. tabulates the results for the respective MOEs for each design point.

Table 15. Refined DOE and results – Part 1.

RUN	100	60	0	0	1											
	140	100	1	1	8											
	0	0	0	0	0											
	Armor	Mobility	ERA	APS	FS	BLUE Casualties	SE	BLUE Percentage Casualties	RED Casualties	SE	RED Percentage Casualties	FER (% Red Casualties / % Blue Casualties)	BLUE Goal	SE	Time to Complete Mission	SE
1	137	70	0	0	8	0.38	0.089852	3.167	23.88	0.408721	58.244	18.393	0.98	0.02	1794.42	16.18917
2	102	79	0	0	8	5.48	0.334713	45.667	21.42	0.624722	52.244	1.144	0.94	0.033927	1831.54	50.7995
3	116	90	0	0	8	2.36	0.193275	19.667	22.22	0.666572	54.195	2.756	0.9	0.042857	1385.26	10.78865
4	126	75	1	0	8	0.02	0.02	0.167	23.36	0.479592	56.976	341.854	0.98	0.02	1672.68	16.58545
5	140	75	1	0	8	0.01	0	0.083	23.52	0.453773	57.366	688.390	0.96	0.027994	1681.2	14.41295
6	132	80	1	0	8	0.01	0	0.083	24.22	0.408372	59.073	708.878	0.96	0.027994	1601.7	11.79866
7	114	62	0	1	8	2.92	0.278245	24.333	23.76	0.395443	57.951	2.382	0.94	0.033927	2153.3	29.55463
8	103	82	0	1	8	3.86	0.339279	32.167	23.6	0.526056	57.561	1.789	0.94	0.033927	1658.24	30.84096
9	113	97	0	1	8	1.76	0.184192	14.667	21.68	0.558014	52.878	3.605	1	0	1274.48	10.04964
10	139	90	1	1	8	0.01	0	0.083	22.62	0.504583	55.171	662.049	0.98	0.02	1374.68	10.65164
11	106	63	0	0	7	5	0.27701	45.455	22.4	0.555492	54.634	1.202	0.72	0.064143	2333.66	63.8966
12	128	72	0	0	7	2.98	0.244932	27.091	23.66	0.530391	57.707	2.130	0.9	0.042857	1850.26	38.56746
13	118	76	0	0	7	2.98	0.293452	27.091	23.62	0.475429	57.610	2.127	0.92	0.038756	1771.14	49.36006
14	128	76	0	0	7	1.76	0.229569	16.000	24.32	0.418393	59.317	3.707	0.96	0.027994	1776.72	41.81275
15	134	87	0	0	7	1.72	0.148571	15.636	22.98	0.505876	56.049	3.585	0.98	0.02	1407.4	15.51736
16	107	95	0	0	7	4.38	0.352125	39.818	22.66	0.493724	55.268	1.388	1	0	1438.36	38.97042
17	107	79	1	0	7	0.42	0.086142	3.818	24.02	0.411558	58.585	15.344	0.96	0.027994	1500.4	12.36093
18	125	65	0	1	7	1.44	0.146134	13.091	23.48	0.456464	57.268	4.375	0.94	0.033927	1930.5	20.34332
19	121	67	0	1	7	1.52	0.154497	13.818	23.4	0.416986	57.073	4.130	1	0	1830.28	18.28395
20	129	67	0	1	7	1.18	0.109507	10.727	24.56	0.487526	59.902	5.584	0.9	0.042857	1879.98	24.99805

Table 16. Refined DOE and results – Part 2.

RUN	100	60	0	0	1											
	140	100	1	1	8											
	0	0	0	0	0											
	Armor	Mobility	ERA	APS	FS	BLUE Casualties	SE	BLUE Percentage Casualties	RED Casualties	SE	RED Percentage Casualties	FER (% Red Casualties / % Blue Casualties)	BLUE Goal	SE	Time to Complete Mission	SE
21	102	87	0	1	7	3.4	0.233867	30.909	21.58	0.479021	52.634	1.703	1	0	1446.76	18.27204
22	131	92	0	1	7	1.02	0.135496	9.273	22.96	0.441667	56.000	6.039	1	0	1356.46	19.33989
23	123	93	0	1	7	1.24	0.163032	11.273	22.58	0.411161	55.073	4.886	1	0	1345.26	17.29211
24	134	95	0	1	7	1.18	0.141969	10.727	23.84	0.511389	58.146	5.420	0.94	0.033927	1343.56	19.56632
25	137	66	1	1	7	0.06	0.033927	0.545	23.86	0.490739	58.195	106.691	0.98	0.02	1810.68	15.89176
26	104	77	1	1	7	0.24	0.073179	2.182	22.96	0.438885	56.000	25.667	1	0	1524.74	11.05931
27	101	91	1	1	7	0.14	0.057214	1.273	22.84	0.480102	55.707	43.770	0.94	0.033927	1281.94	9.877925
28	135	93	1	1	7	0.04	0.027994	0.364	22.54	0.531621	54.976	151.183	0.94	0.033927	1274.04	10.12755
29	118	60	0	0	6	3.5	0.221774	31.818	20.54	0.405281	50.098	1.574	1	0	1845.66	34.25241
30	123	64	0	0	6	3.12	0.2613	28.364	21.76	0.414591	53.073	1.871	0.98	0.02	1858.82	57.82057
31	123	96	0	0	6	2.66	0.213063	24.182	19.98	0.523325	48.732	2.015	1	0	1109.26	20.24327
32	131	99	0	0	6	2.16	0.181513	19.636	19.26	0.531313	46.976	2.392	1	0	1020.46	12.3426
33	107	71	1	0	6	0.5	0.122057	4.545	20.52	0.412301	50.049	11.011	1	0	1366.42	15.62899
34	109	71	1	0	6	0.26	0.079847	2.364	20.16	0.413408	49.171	20.803	1	0	1345.1	12.64027
35	138	74	1	0	6	0.28	0.081014	2.545	19.2	0.416006	46.829	18.397	1	0	1287.6	11.3154
36	118	88	1	0	6	0.36	0.079591	3.273	19.54	0.449226	47.659	14.562	1	0	1077.02	11.31755
37	108	91	1	0	6	0.36	0.093721	3.273	18.74	0.514928	45.707	13.966	1	0	1062	11.93383
38	120	68	0	1	6	2	0.187355	18.182	17.44	0.629972	42.537	2.340	0.98	0.02	1593.2	42.53283
39	115	74	0	1	6	2.1	0.237762	19.091	18.1	0.439155	44.146	2.312	0.98	0.02	1492	48.93484
40	128	82	0	1	6	1.54	0.151752	14.000	17.64	0.451537	43.024	3.073	1	0	1239.52	22.25229
41	101	89	0	1	6	2.9	0.242857	26.364	17.18	0.476115	41.902	1.589	1	0	1197.54	30.43527
42	121	62	1	1	6	0.08	0.038756	0.727	17.34	0.462125	42.293	58.152	1	0	1555.36	21.0419
43	110	63	1	1	6	0.16	0.052372	1.455	17.88	0.474355	43.610	29.982	1	0	1526.24	22.70337
44	124	78	1	1	6	0.1	0.042857	0.909	17.42	0.508772	42.488	46.737	1	0	1218.16	15.43575
45	108	81	1	1	6	0.12	0.046423	1.091	16.18	0.362182	39.463	36.175	1	0	1154.26	12.8904
46	104	83	1	1	6	0.04	0.04	0.364	16.54	0.370559	40.341	110.939	1	0	1119.34	12.23457
47	121	92	0	0	5	3.5	0.329811	35.000	22.36	0.60593	54.537	1.558	0.9	0.042857	1556.68	63.18201
48	114	96	0	0	5	2.78	0.179091	27.800	22.74	0.477929	55.463	1.995	0.98	0.02	1309.26	15.83499
49	110	99	0	0	5	3.38	0.26169	33.800	21.68	0.551392	52.878	1.564	0.98	0.02	1285.54	36.80467
50	105	75	1	0	5	0.9	0.151859	9.000	23.94	0.410485	58.390	6.488	0.96	0.027994	1637.76	16.13106

Table 17. Refined DOE and results – Part 3.

RUN	100	60	0	0	1												
	140	100	1	1	8												
	0	0	0	0	0												
	Armor	Mobility	ERA	APS	FS	BLUE Casualties	SE	BLUE Percentage Casualties	RED Casualties	SE	RED Percentage Casualties	FER (% Red Casualties / % Blue Casualties)	BLUE Goal	SE	Time to Complete Mission	SE	
51	108	83	1	0	5	0.56	0.131429	5.600	24.48	0.470553	59.707	10.662	0.94	0.033927	1435.7	13.35702	
52	137	87	1	0	5	0.66	0.144589	6.600	24.54	0.418169	59.854	9.069	0.92	0.038756	1369.68	10.89667	
53	105	94	1	0	5	0.46	0.121923	4.600	23.94	0.496033	58.390	12.694	0.94	0.033927	1267.74	12.72734	
54	122	98	1	0	5	0.44	0.111245	4.400	24.12	0.41467	58.829	13.370	0.96	0.027994	1212.06	10.8891	
55	127	98	1	0	5	0.5	0.128571	5.000	23.6	0.466861	57.561	11.512	1	0	1215.3	7.738388	
56	129	99	1	0	5	0.46	0.107703	4.600	24.14	0.431429	58.878	12.800	0.98	0.02	1189.92	8.072773	
57	115	60	0	1	5	2.46	0.19211	24.600	23.7	0.40933	57.805	2.350	0.94	0.033927	2148.94	40.32764	
58	129	69	0	1	5	1.78	0.16485	17.800	23.7	0.474879	57.805	3.247	0.96	0.027994	1754.42	19.41035	
59	112	72	1	1	5	0.26	0.07456	2.600	24.78	0.462725	60.439	23.246	0.98	0.02	1667.84	16.2371	
60	116	73	1	1	5	0.22	0.071657	2.200	24	0.38119	58.537	26.608	0.98	0.02	1631.42	10.62931	
61	140	78	1	1	5	0.16	0.072054	1.600	24.16	0.506577	58.927	36.829	0.94	0.033927	1528.52	13.38663	
62	120	80	1	1	5	0.16	0.052372	1.600	23.7	0.436358	57.805	36.128	0.98	0.02	1457.76	12.45909	
63	130	84	1	1	5	0.1	0.051508	1.000	24.18	0.444182	58.976	58.976	0.96	0.027994	1391.08	10.26434	
64	136	86	1	1	5	0.14	0.04957	1.400	24.34	0.394462	59.366	42.404	0.98	0.02	1414.06	14.75491	
65	113	94	1	1	5	0.18	0.061875	1.800	24.26	0.401843	59.171	32.873	0.96	0.027994	1268.68	10.38325	
66	127	66	0	0	4	4.48	0.164726	49.778	17.26	0.600551	42.098	0.846	0.38	0.069341	2586.32	81.61745	
67	104	74	0	0	4	4.68	0.220278	52.000	18.36	0.504478	44.780	0.861	0.54	0.0712	2320.46	92.70334	
68	110	76	0	0	4	4.9	0.249489	54.444	17.92	0.541231	43.707	0.803	0.66	0.067673	2163.6	89.38185	
69	100	82	0	0	4	4.68	0.273212	52.000	20.14	0.577122	49.122	0.945	0.88	0.046423	1828.9	72.18511	
70	124	88	0	0	4	4.72	0.2829	52.444	18.86	0.567134	46.000	0.877	0.72	0.064143	1924.68	101.1142	
71	128	88	0	0	4	4.62	0.255375	51.333	18.86	0.471221	46.000	0.896	0.72	0.064143	1949.22	99.86858	
72	111	91	1	0	4	0.6	0.12454	6.667	18.42	0.414128	44.927	6.739	1	0	1169.18	11.89055	
73	125	100	1	0	4	0.56	0.118356	6.222	19.06	0.432751	46.488	7.471	1	0	1063.42	12.1997	
74	111	61	0	1	4	4.34	0.238379	48.222	19.4	0.642698	47.317	0.981	0.8	0.057143	2413.56	61.85394	
75	113	62	0	1	4	4.14	0.206051	46.000	20.4	0.515079	49.756	1.082	0.84	0.052372	2374.08	60.74923	
76	118	63	0	1	4	3.68	0.220278	40.889	19.16	0.557955	46.732	1.143	0.8	0.057143	2235.74	70.35028	
77	135	66	0	1	4	3.9	0.208493	43.333	18.96	0.440741	46.244	1.067	0.64	0.068571	2315.58	80.25963	
78	103	73	0	1	4	4.34	0.218735	48.222	20.96	0.50706	51.122	1.060	0.88	0.046423	2088.28	67.42191	
79	133	77	0	1	4	3.54	0.230722	39.333	19.46	0.432562	47.463	1.207	0.88	0.046423	1818.74	71.92744	
80	135	85	0	1	4	3.38	0.224772	37.556	18.72	0.545886	45.659	1.216	0.86	0.04957	1698.26	81.42635	

Table 18. Refined DOE and results – Part 4.

RUN	100	60	0	0	1												
	140	100	1	1	8												
	0	0	0	0	0												
	Armor	Mobility	ERA	APS	FS	BLUE Casualties	SE	BLUE Percentage Casualties	RED Casualties	SE	RED Percentage Casualties	FER (% Red Casualties / % Blue Casualties)	BLUE Goal	SE	Time to Complete Mission	SE	
81	130	61	1	1	4	0.7	0.115175	7.778	19.58	0.427704	47.756	6.140	1	0	1735.9	16.48112	
82	126	64	1	1	4	0.96	0.142743	10.667	19.76	0.46208	48.195	4.518	1	0	1697.92	26.83858	
83	119	68	1	1	4	0.48	0.082015	5.333	19.54	0.438187	47.659	8.936	1	0	1550.5	10.22814	
84	136	77	0	0	3	3.08	0.278245	30.800	17.08	0.677836	41.659	1.353	0.94	0.033927	1732.38	67.34804	
85	132	79	0	0	3	2.32	0.208865	23.200	16.48	0.671422	40.195	1.733	0.98	0.02	1439.38	37.92585	
86	116	83	0	0	3	3.3	0.286071	33.000	17.92	0.669962	43.707	1.324	0.98	0.02	1464.06	49.92356	
87	130	97	0	0	3	2.24	0.184192	22.400	17.76	0.653131	43.317	1.934	0.98	0.02	1111	24.67048	
88	119	98	0	0	3	2.66	0.246792	26.600	17.36	0.517261	42.341	1.592	1	0	1140.44	27.81829	
89	139	71	1	0	3	0.28	0.081014	2.800	15.88	0.545587	38.732	13.833	1	0	1354.46	24.54627	
90	112	78	1	0	3	0.28	0.075809	2.800	13.98	0.421358	34.098	12.178	1	0	1182.44	18.97184	
91	125	86	1	0	3	0.22	0.065714	2.200	14.18	0.444182	34.585	15.721	1	0	1077.42	21.81857	
92	120	92	1	0	3	0.36	0.08926	3.600	14.86	0.535293	36.244	10.068	1	0	1015.64	23.52239	
93	132	69	0	1	3	1.4	0.148461	14.000	15.38	0.538244	37.512	2.679	1	0	1428.32	31.76406	
94	122	72	0	1	3	1.9	0.221774	19.000	15.86	0.574996	38.683	2.036	1	0	1509.12	45.57684	
95	102	86	0	1	3	2.72	0.277069	27.200	15.46	0.57797	37.707	1.386	0.94	0.033927	1293.32	69.23975	
96	131	89	0	1	3	1.4	0.145686	14.000	14.2	0.475523	34.634	2.474	1	0	1090.56	24.20611	
97	133	89	0	1	3	1.34	0.160636	13.400	14.8	0.534522	36.098	2.694	1	0	1129.6	26.12554	
98	109	61	1	1	3	0.08	0.048149	0.800	14.58	0.53076	35.561	44.451	1	0	1472.58	21.71602	
99	117	64	1	1	3	0.12	0.061545	1.200	14.54	0.449226	35.463	29.553	1	0	1406.1	21.26874	
100	117	96	1	1	3	0.1	0.042857	1.000	13.78	0.399275	33.610	33.610	1	0	934.9	13.08971	
101	122	100	1	1	3	0.01	0	0.100	14.98	0.433768	36.537	365.366	1	0	927.4	15.26469	
102	105	67	0	0	2	5.78	0.268465	57.800	16.94	0.612396	41.317	0.715	0.86	0.04957	1936	74.6633	
103	139	69	0	0	2	3.44	0.208317	34.400	17.2	0.577821	41.951	1.220	1	0	1627.06	36.97116	
104	136	83	0	0	2	3.3	0.178999	33.000	18.5	0.511301	45.122	1.367	1	0	1433.98	51.60676	
105	103	94	0	0	2	4.76	0.323955	47.600	15.28	0.546633	37.268	0.783	0.96	0.027994	1232.04	64.16409	
106	106	65	1	0	2	0.48	0.111538	4.800	16.6	0.5087	40.488	8.435	1	0	1428.66	22.52878	
107	109	68	1	0	2	0.56	0.128285	5.600	17.2	0.50224	41.951	7.491	1	0	1385.66	23.92493	
108	117	68	1	0	2	0.58	0.110988	5.800	17.2	0.499796	41.951	7.233	1	0	1377.06	24.07245	
109	138	73	1	0	2	0.64	0.136307	6.400	16.22	0.511333	39.561	6.181	1	0	1309.12	28.02111	
110	111	93	1	0	2	0.4	0.106904	4.000	15.82	0.545625	38.585	9.646	1	0	986.82	19.95496	

Table 19. Refined DOE and results – Part 5.

RUN	100	60	0	0	1												
	140	100	1	1	8												
	0	0	0	0	0												
	Armor	Mobility	ERA	APS	FS	BLUE Casualties	SE	BLUE Percentage Casualties	RED Casualties	SE	RED Percentage Casualties	FER (% Red Casualties / % Blue Casualties)	BLUE Goal	SE	Time to Complete Mission	SE	
111	119	93	1	0	2	0.28	0.070218	2.800	16.4	0.603392	40.000	14.286	1	0	1006.4	15.0198	
112	115	95	1	0	2	0.32	0.083005	3.200	16.42	0.615507	40.049	12.515	1	0	961.28	16.85797	
113	133	81	0	1	2	0.12	0.046423	1.200	16.98	0.578167	41.415	34.512	1	0	1126	16.78819	
114	133	65	1	1	2	0.12	0.046423	1.200	16.76	0.492855	40.878	34.065	1	0	1386.4	18.68224	
115	106	73	1	1	2	0.22	0.125487	2.200	16.38	0.52752	39.951	18.160	0.98	0.02	1257.28	40.25356	
116	113	84	1	1	2	0.16	0.059659	1.600	15.58	0.540665	38.000	23.750	1	0	1048.28	16.32199	
117	123	84	1	1	2	0.14	0.057214	1.400	15.82	0.498725	38.585	27.561	1	0	1067.34	15.93073	
118	112	88	1	1	2	0.1	0.051508	1.000	15.92	0.529027	38.829	38.829	1	0	1053.3	17.54556	
119	134	97	1	1	2	0.08	0.038756	0.800	15.8	0.667007	38.537	48.171	1	0	948.98	17.64117	
120	101	70	0	0	1	5.18	0.276553	57.556	14.62	0.550243	35.659	0.620	0.76	0.061012	1868.28	103.085	
121	127	63	1	0	1	1.14	0.151213	12.667	15.66	0.547059	38.195	3.015	1	0	1473.18	22.079	
122	138	78	1	0	1	0.72	0.156596	8.000	15.94	0.453926	38.878	4.860	1	0	1163.32	17.60432	
123	126	98	1	0	1	0.52	0.122024	5.778	15.28	0.44998	37.268	6.450	1	0	936.02	12.733	
124	108	80	0	1	1	3.44	0.257397	38.222	13.74	0.492234	33.512	0.877	0.92	0.038756	1406.02	80.85161	
125	100	85	0	1	1	3	0.211891	33.333	13.24	0.424322	32.293	0.969	1	0	1083.92	27.21458	
126	114	85	0	1	1	3.26	0.220963	36.222	14.04	0.47891	34.244	0.945	0.94	0.033927	1229.36	68.97346	
127	124	70	1	1	1	0.38	0.102579	4.222	14.9	0.361685	36.341	8.607	1	0	1275.4	18.63392	
128	138	81	1	1	1	0.3	0.082065	3.333	15.56	0.453701	37.951	11.385	1	0	1111.54	15.97294	
129	103	90	1	1	1	0.38	0.094286	4.222	14.34	0.431996	34.976	8.284	1	0	987.28	13.88851	

THIS PAGE INTENTIONALLY LEFT BLANK

## LIST OF REFERENCES

- abcNEWS. 2014, March 27. "abcNEWS." *Russian Kornet Anti-Tank Missile FAQ*.  
<http://abcnews.go.com/International/story?id=79586> .
- Armada. "Armoured Vehicle Protection." 2013, April. *Armada International*.  
<http://www.armada.ch/wp-content/uploads/2013/04/Compendium-2-April13.pdf> .
- Army Technology. 2014, August 1. *Bradley M2/M3 Tracked Armoured Fighting Vehicle, United States of America*. <http://www.army-technology.com/projects/bradley/>.
- . 2013. *Stryker Armoured Combat Vehicle Family, United States of America*.  
<http://www.army-technology.com/projects/stryker/>.
- Boettcher III, William A., and Michael D. Cobb. 2006. "Echoes of Vietnam? Casualty Framing and Public Perception of Success and Failure in Iraq." *Journal of Conflict Resolution*: 831–854.
- Bonsor, Kevin. 2014, September 1. "howstuffworks." *How Landmines Work*. 2012.  
<http://science.howstuffworks.com/landmine4.htm>.
- Cioppa, Thomas M, and Thomas W Lucas. 2007. "Efficient Nearly Orthogonal and Space-Filling Latin Hypercubes." *Technometrics*, 11.
- Coolahan, James E. 2003. "Modeling and Simulation at APL." *John Hopkins APL Technical Digest*, 12.
- Defense Update. 2014, September 1. *RPG-29V*. 2006. <http://defense-update.com/products/r/rpg-29.htm>.
- Federation of American Scientist. 1999. "Military Analysis Network. M2 .50 Caliber [12.7mm] Machine Gun. Last modified January 21. <http://fas.org/man/dod-101/sys/land/m2-50cal.htm>.
- Foo, Ceying. 2014. "M1A2 Abrams Main Battle Tank." SE 4150: System Architecting and Design Individual Project Report, Monterey, Naval Postgraduate School.
- GlobalSecurity.org. 2014, August 6. *FM3-21.94 Chapter 6 Urban Environment*. 2006.  
<http://www.globalsecurity.org/militarylibrary/policy/army/fm/3-21-94/c06.htm>.
- Hayter, Anthony. 2012. *Probability and Statistics for Engineers and Scientists*. Boston: Brooks/Cole.
- Kable Intelligence Limited. 2014, August 30. "Army-Technology." 2014. [www.army-technology.com/projects/abrams/](http://www.army-technology.com/projects/abrams/).

- Kempinski, Bernard, and Christopher Murphy. 2012. *Technical Challenges of the U.S. Army's Ground Combat Vehicle Program*. Working Paper Series, Washington, D.C: Congressional Budget Office.
- Krulak, Charles C. 1999, January. "The Strategic Corporal: Leadership in the Three Block War." *Marines Magazine*.
- Kwok, Richard, and Eng Teong Lim. 2013. *Passive Armor*. Singapore: Singapore Technology Kinetics.
- Larson, Eric V. 1996. *Casualties and Consensus: The Historical Role of Casualties in Domestic Support for U.S. Military Operations*. Santa Monica, CA: RAND.
- National Academies. 2014, August 1. *IED Attack: Improvised Explosive Device*. [http://www.dhs.gov/xlibrary/assets/prep\\_ied\\_fact\\_sheet.pdf](http://www.dhs.gov/xlibrary/assets/prep_ied_fact_sheet.pdf).
- Osborn, Kris. 2007, April 13. "Army Officials Tout Success of Reactive Armor." *Army Times*. <http://www.armytimes.com/article/20070413/NEWS/704130334/Army-officials-tout-success-reactive-armor>.
- Princeton University. 2014, August 5. "Introduction to Regression. " [http://dss.princeton.edu/online\\_help/analysis/regression\\_intro.htm](http://dss.princeton.edu/online_help/analysis/regression_intro.htm).
- Ragsdale, Cliff T. 2012. *Spreadsheet Modeling & Decision Analysis*. Mason, Ohio: South-Western Cengage Learning.
- Sanchez, Susan. 2007. "Work Smarter, Not Harder: Guidelines for Designing Simulation Experiments." *Proceedings of the 2007 Winter Simulation Conference*: 84–94.
- SAS Institute. 2012. *JMP 10 Modeling and Multivariate Methods*. Cary: SAS Institute.
- SE Handbook Working Group. 2010. *Systems Engineering Handbook - A Guide for System Life Cycle Processes and Activities*. San Diego: INCOSE.
- SEA Cohort 20. 2014. "Distributed Surface Force." Systems Engineering Analysis Capstone Project Report, Naval Postgraduate School.
- Sher, E, S Refael, and D Luria. 1988. "Agility and Manoeuvrability as Passive Defence for Armored Vehicles." *Journal of Automobile Engineering*: 7.
- Somaiya, Ravi. 2010, October 14. "Why Rebel Groups Love the Toyota Hilux." *Newsweek*. <http://www.newsweek.com/why-rebel-groups-love-toyota-hilux-74195>.

- Sullivan, L. Patricia. 2008. "Sustaining the Fight: A Cross-Sectional Time-Series Analysis of Public Support for Ongoing Military Interventions." *Conflict Management and Peace Science*: 112–135.
- Sullivan, Patricia L. 2008. "At What Price Victory? The Effects of Uncertainty on Military Intervention Duration and Outcome." *Conflict Management and Peace Science*: 49–66.
- Treml, Tobias. 2013. "A Revolutionary Approach for the Development of Future Ground Combat Systems Specifications." Masters thesis, Naval Postgraduate School.
- United States Army. 2013. *Field Manual 3-90-2: Reconnaissance, Security and Tactical Enabling Tasks Volume 2*. Washington, DC: United States Army.
- . 2005. *Field Manual 5-0: Army Planning and Orders Production*. Washington, DC: United States Army.
- . 2012, February 15. "HBCTs METL." *Combined Arms Battalion Collective Task Publication*. Washington, DC: United States Army.  
<https://rdl.train.army.mil/catalog-ws/view/100.ATSC/3185017A-E506-4FF0-B63C-D20EB15F4A18-1331841293082/appb.htm>.
- Urban Warfare Special. 2006, July 1. "Improving Visibility in "Buttoned Up" Tanks." *Defense Update*. <http://www.defense-update.com/features/du-1-06/urban-armor-2.htm>.
- Yap, Chun Hong Kelvin. 2012. *The Impact of Armor on the Design, Utilization and Survivability of Ground Vehicles: The History of Armor Development and Use*. Master Thesis, Monterey: Naval Postgraduate School.

THIS PAGE INTENTIONALLY LEFT BLANK

## **INITIAL DISTRIBUTION LIST**

1. Defense Technical Information Center  
Ft. Belvoir, Virginia
2. Dudley Knox Library  
Naval Postgraduate School  
Monterey, California