



**NAVAL
POSTGRADUATE
SCHOOL**

MONTEREY, CALIFORNIA

THESIS

**UTILIZING AN ENERGY MANAGEMENT SYSTEM
WITH DISTRIBUTED RESOURCES TO MANAGE
CRITICAL LOADS AND REDUCE ENERGY COSTS**

by

David J. Gustafson

September 2014

Thesis Advisor:
Co-Advisor:

Giovanna Oriti
Alexander L. Julian

Approved for public release; distribution is unlimited

THIS PAGE INTENTIONALLY LEFT BLANK

REPORT DOCUMENTATION PAGE			<i>Form Approved OMB No. 0704-0188</i>	
Public reporting burden for this collection of information is estimated to average 1 hour per response, including the time for reviewing instruction, searching existing data sources, gathering and maintaining the data needed, and completing and reviewing the collection of information. Send comments regarding this burden estimate or any other aspect of this collection of information, including suggestions for reducing this burden, to Washington headquarters Services, Directorate for Information Operations and Reports, 1215 Jefferson Davis Highway, Suite 1204, Arlington, VA 22202-4302, and to the Office of Management and Budget, Paperwork Reduction Project (0704-0188) Washington DC 20503.				
1. AGENCY USE ONLY (Leave blank)		2. REPORT DATE September 2014	3. REPORT TYPE AND DATES COVERED Master's Thesis	
4. TITLE AND SUBTITLE UTILIZING AN ENERGY MANAGEMENT SYSTEM WITH DISTRIBUTED RESOURCES TO MANAGE CRITICAL LOADS AND REDUCE ENERGY COSTS			5. FUNDING NUMBERS	
6. AUTHOR(S) David J. Gustafson				
7. PERFORMING ORGANIZATION NAME(S) AND ADDRESS(ES) Naval Postgraduate School Monterey, CA 93943-5000			8. PERFORMING ORGANIZATION REPORT NUMBER	
9. SPONSORING /MONITORING AGENCY NAME(S) AND ADDRESS(ES) N/A			10. SPONSORING/MONITORING AGENCY REPORT NUMBER	
11. SUPPLEMENTARY NOTES The views expressed in this thesis are those of the author and do not reflect the official policy or position of the Department of Defense or the U.S. Government. IRB Protocol number ___N/A___.				
12a. DISTRIBUTION / AVAILABILITY STATEMENT Approved for public release; distribution is unlimited			12b. DISTRIBUTION CODE	
13. ABSTRACT (maximum 200 words) Energy security is critical to the DOD and can be achieved using different methods, but for DOD installations cost effectiveness must be taken into consideration when evaluating energy security goals. Energy Storage Systems (ESSs) have a wide range of associated technologies as well as large differences in cost and capabilities. This study examines the cost effectiveness of utilizing an ESS to perform peak shaving with an Energy Management System (EMS). An EMS used with an ESS can perform several functions that can be beneficial to the grid. These functions include peak shaving, conducting power factor correction, matching critical load to most efficient distributed resource, and islanding a system during commercial grid disruption. While utilizing an ESS within a microgrid allows several benefits, to include peak shaving, the ability to utilize photovoltaic arrays during islanding, and power factor correction, the implementation of the ESS by itself is likely to prove cost prohibitive. The DOD requires energy projects to have net savings over the life cycle of the project and in areas without high differential between peak power and off-peak power, this goal will be difficult to achieve.				
14. SUBJECT TERMS Energy Management System, Energy Storage Systems, Energy Storage			15. NUMBER OF PAGES 77	
			16. PRICE CODE	
17. SECURITY CLASSIFICATION OF REPORT Unclassified	18. SECURITY CLASSIFICATION OF THIS PAGE Unclassified	19. SECURITY CLASSIFICATION OF ABSTRACT Unclassified	20. LIMITATION OF ABSTRACT UU	

THIS PAGE INTENTIONALLY LEFT BLANK

Approved for public release; distribution is unlimited

**UTILIZING AN ENERGY MANAGEMENT SYSTEM WITH DISTRIBUTED
RESOURCES TO MANAGE CRITICAL LOADS AND REDUCE ENERGY
COSTS**

David J. Gustafson
Major, United States Marine Corps
B.S., United States Naval Academy, 1999

Submitted in partial fulfillment of the
requirements for the degree of

MASTER OF SCIENCE IN ELECTRICAL ENGINEERING

from the

**NAVAL POSTGRADUATE SCHOOL
September 2014**

Author: David J. Gustafson

Approved by: Giovanna Oriti
Thesis Advisor

Alexander L. Julian
Co-Advisor

R. Clark Robertson
Chair, Department of Electrical and Computer Engineering

THIS PAGE INTENTIONALLY LEFT BLANK

ABSTRACT

Energy security is critical to the DOD and can be achieved using different methods, but for DOD installations cost effectiveness must be taken into consideration when evaluating energy security goals. Energy Storage Systems (ESSs) have a wide range of associated technologies as well as large differences in cost and capabilities. This study examines the cost effectiveness of utilizing an ESS to perform peak shaving with an Energy Management System (EMS). An EMS used with an ESS can perform several functions that can be beneficial to the grid. These functions include peak shaving, conducting power factor correction, matching critical load to most efficient distributed resource, and islanding a system during commercial grid disruption.

While utilizing an ESS within a microgrid allows several benefits, to include peak shaving, the ability to utilize photovoltaic arrays during islanding, and power factor correction, the implementation of the ESS by itself is likely to prove cost prohibitive. The DOD requires energy projects to have net savings over the life cycle of the project and in areas without high differential between peak power and off-peak power, this goal will be difficult to achieve.

THIS PAGE INTENTIONALLY LEFT BLANK

TABLE OF CONTENTS

I.	INTRODUCTION.....	1
A.	BACKGROUND	1
B.	OBJECTIVE	3
C.	RELATED WORK	3
D.	THESIS ORGANIZATION.....	4
II.	MICROGRID ANALYSIS.....	5
A.	INTRODUCTION.....	5
B.	PHOTOVOLTAIC ARRAYS.....	5
C.	ENERGY STORAGE SYSTEMS	7
1.	Chemical Batteries	9
a.	<i>Lead Acid Battery.....</i>	<i>10</i>
b.	<i>Flow Battery</i>	<i>11</i>
c.	<i>Lithium Ion Battery</i>	<i>13</i>
d.	<i>Sodium Nickel Chloride Batteries</i>	<i>14</i>
2.	Fuel Cells.....	15
3.	Flywheels.....	16
4.	Other Energy Storage Devices	17
5.	Energy Storage System for Simulation	19
D.	LOAD PROFILE AND ENERGY COSTS FOR NPS	20
E.	CRITICAL INFRASTRUCTURE	23
III.	ENERGY MANAGEMENT SYSTEM.....	27
A.	INTRODUCTION.....	27
B.	EMS FUNCTIONALITY.....	28
1.	Peak Shaving	31
2.	Uninterrupted Power to Critical Loads.....	31
C.	CONCLUSION	32
IV.	A SAMPLE SCENARIO USING THE EMS FOR PEAK SHAVING.....	33
A.	PEAK SHAVING USING THE EMS WITH 400 KWH STORAGE AND 200KW PEAK POWER ESS	34
1.	Battery Efficiency.....	36
2.	Cost Analysis	36
B.	CONCLUSIONS	39
V.	CONCLUSIONS AND FUTURE WORK.....	41
A.	CONCLUSIONS	41
B.	FUTURE WORK.....	42
	APPENDIX A. DURATHON BATTERY DATA SHEET.....	45
	APPENDIX B. PG&E NPS POWER BILL	47
	LIST OF REFERENCES	49
	INITIAL DISTRIBUTION LIST	53

THIS PAGE INTENTIONALLY LEFT BLANK

LIST OF FIGURES

Figure 1.	MPPT algorithm embedded in a PV inverter, from [8].	7
Figure 2.	Simplified operating point for load and PV array, from [13].	7
Figure 3.	Sample load profile for the NPS with actual PV power ratings for the same time period, after [14].	8
Figure 4.	Discharge time and system power ratings for various energy storage technologies, from [15].	9
Figure 5.	Discharge time and rated power for battery technologies, from [16].	10
Figure 6.	Lead acid battery configuration, from [17].	11
Figure 7.	Vanadium redox battery, from [15].	12
Figure 8.	The two most common lithium ion cell topographies, from [15].	14
Figure 9.	Sodium nickel chloride battery with description, from [15].	15
Figure 10.	PEM fuel cell, from [13].	16
Figure 11.	Summary of costs of chemical energy storage devices, from [24].	20
Figure 12.	Simulated load profile for Ingersoll Hall, 04/01/2014–04/07/2014, after [14].	23
Figure 13.	Ingersoll Hall profile with critical load shown and a 150 kWh battery.	25
Figure 14.	Diagram of EMS functionality.	29
Figure 15.	EMS schematic, from [27].	30
Figure 16.	Load profile for the NPS campus with PV and ESS.	35
Figure 17.	Installed cost for sodium-nickel-chloride batteries, from [15].	38

THIS PAGE INTENTIONALLY LEFT BLANK

LIST OF TABLES

Table 1.	DOE energy storage technologies, after [23].....	18
Table 2.	Comparison of costs for peak shaving.....	38

THIS PAGE INTENTIONALLY LEFT BLANK

LIST OF ACRONYMS AND ABBREVIATIONS

AARA	American Recovery and Reinvestment Act
AC	Alternating Current
DC	Direct Current
DCLA	Deep-Cycle Lead-Acid (batteries)
DG	distributed generation
DOD	Department of Defense
DOE	Department of Energy
DR	distributed resource
EMS	energy management system
ESS	energy storage system
EPS	Electric Power System
FPGA	Field Programmed Gate Array
IG	Inspector General
JCTD	Joint Capabilities Technology Demonstration
LCCA	Life Cycle Cost Analysis
MHEES	Medium Hybrid Expeditionary Energy System
MPPT	Maximum Power Point Tracking
NPS	Naval Postgraduate School
O&M	operations and maintenance
PEM	Proton Exchange Membrane
PF	power factor
PG&E	Pacific Gas and Electric
PV	photovoltaic
PWM	Pulse Width Modulation
UPS	uninterrupted power supply
SPIDERS	Smart Power Infrastructure Demonstration for Energy Reliability and Security
THD	Total Harmonic Distortion
TOU	Time Of Use
WAPA	Western Area Power Administration

THIS PAGE INTENTIONALLY LEFT BLANK

EXECUTIVE SUMMARY

The Department of Defense (DOD) has recently taken great interest in its energy consumption across all facets of the organization and implemented several organizational goals and strategies to reduce the risk associated with its high energy usage. One of the goals of the DOD strategy is to improve energy security at fixed installations [1]. Currently the majority of energy used on fixed installations is provided via the commercial electric grid. This makes the DOD reliant on the commercial entities that control that grid for its own energy security. One of the means for reducing that dependency is to develop microgrids on the installations that utilize distributed energy resources to power the installation or key infrastructure on the installation.

Microgrids are distributed resources (DRs) island systems that consist of DR and critical and non-critical loads, the ability to be connected to or disconnected from area Electric Power Systems (EPSs) (i.e., the commercial grid and are intentionally planned) [2]. The DR island system must be able disconnect from and parallel with the area EPS. DR refers to any sources of electric power that are not directly connected to the main electric grid and includes electric generation and storage systems.

The objective of this study is to prove that by utilizing an EMS an installation can provide energy security for critical infrastructure, while using peak shaving to reduce costs and provide improved power quality. The EMS model that is going to be used is based on the work done in previous thesis research at the Naval Postgraduate School (NPS) and will incorporate an energy storage system as well as the Photovoltaic system that is currently installed at NPS [3], [4]. The contribution of this thesis is in establishing if an Energy Storage System (ESS) as part of a microgrid is worth the initial investment in terms of energy security, functionality, and cost savings.

NPS has a total of 187.4 kW of solar photovoltaic (PV) cells installed on top of three academic buildings that are monitored and provide real-time 15 minute data via a web-based service. The PV arrays are grid tied via an inverter and accomplish the main goal of reducing peak power consumption and demand by generating the majority of their

power during peak rate times. However, the PV arrays aren't set-up to provide power to anything during grid disruption.

Energy storage systems provide the capability to store energy during off-peak time periods and discharge it during peak periods. They can also be utilized in conjunction with PV arrays to provide islanding capability if the critical loads are small enough. The estimates for installation costs for an ESS vary widely based on size and capability of the ESS. The demand for improved ESSs has continued to improve technologies and has also driven down life cycle costs for many ESS applications. All ESSs have efficiency losses and installation costs that can range from \$1000 to over \$12000 per kW installed [5]. Figure 1 shows some of the different ESS technologies as well as some of the functions that they are used for.

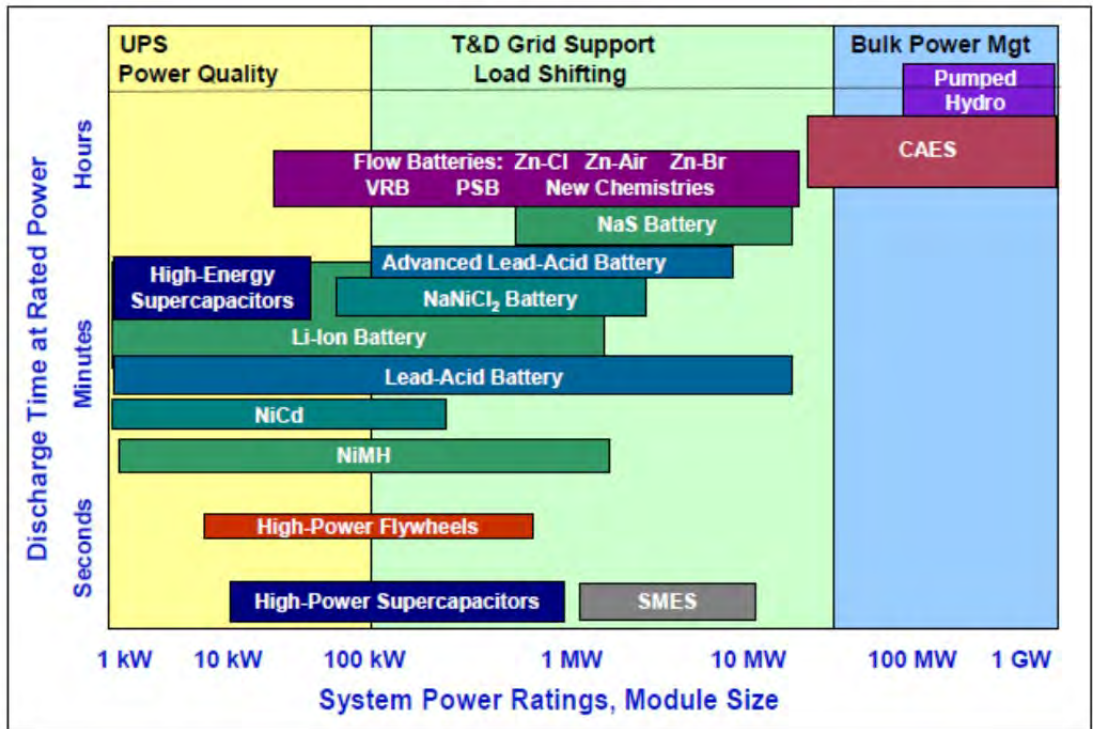

Figure 1. Power rating versus discharge time for different ESS technologies from [5].

A load profile is shown in Figure 2 for a building on the NPS campus that was simulated from historical data on yearly usage, a Pacific Gas and Electric (PG&E) power bill, and metered data from other naval installations. To generate the load profile, a model

was created that used 15 minute data with the PG&E rates to give a cost for the 29 day billing period. The 15 minute data was adjusted from an estimated baseline and used the PG&E maximum power demands for the two separate time periods. The adjustments were made using linear modifiers to adjust the profile until it closely matched the PG&E bill for demand and energy charges. The profile was iteratively adjusted until it was within 2% of the actual costs for the PG&E bill.

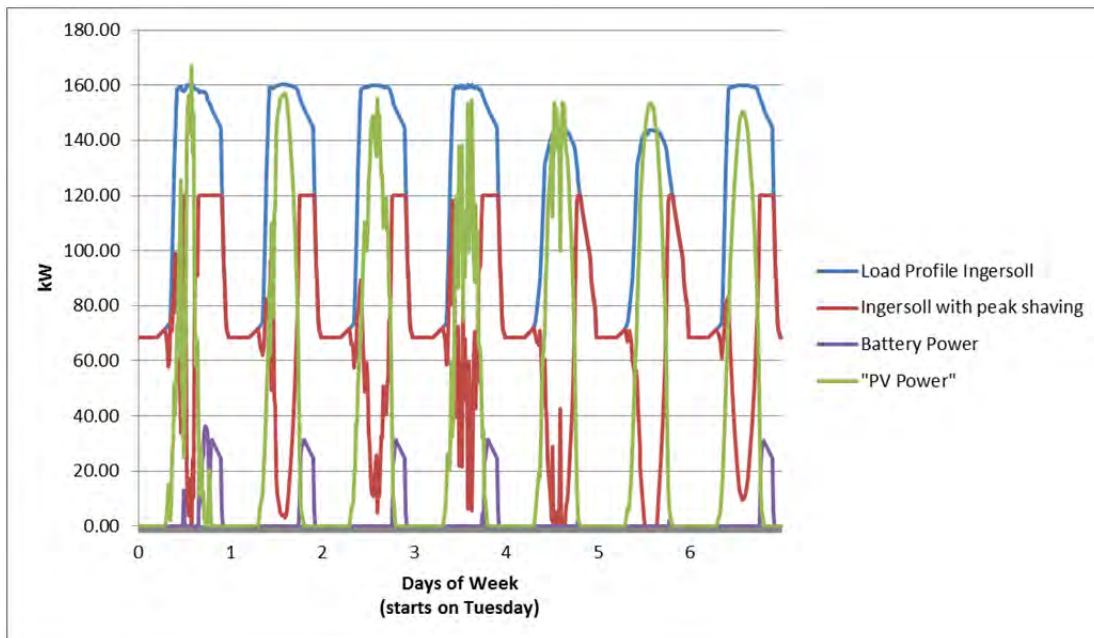

Figure 2. Simulated load profile of Ingersoll Hall for 1–7 April 2014.

In the load profile shown for Figure 2, a 50 kW 100 kWh battery was used to conduct peak shaving. The effect of the battery alone only resulted in energy savings of \$225 for the month. None of the installation costs for any of the ESS technologies would allow this to be a cost effective solution. An ESS used with an EMS could act as an Uninterrupted Power Supply for a critical load however and would then also allow it be utilized for peak shaving. The other main advantage provided by the installation of the EMS with an ESS is the potential use of the PV arrays during grid disruption.

In the next scenario we used an ESS that would be able to handle the maximum power of the solar arrays and have appropriate sized energy storage for that application. The ESS was sized to be a 200 kW / 400 kWh battery bank. The PV array data was taken

for a 29 day time period starting on June 1, 2014, and the cost estimate was done using PG&E summer rates for the E20 service contract. The profile shown in Figure 3 was made assuming that the battery would be charged during off-peak time periods and it was scheduled to be charged from 2200 until 0630 every day. This 8.5 hour charge time is the maximum amount of charge time required to meet full battery capacity if the battery was completely discharged. The battery discharges its energy during peak time periods (1200–1600) and the data shown is for a full discharge.

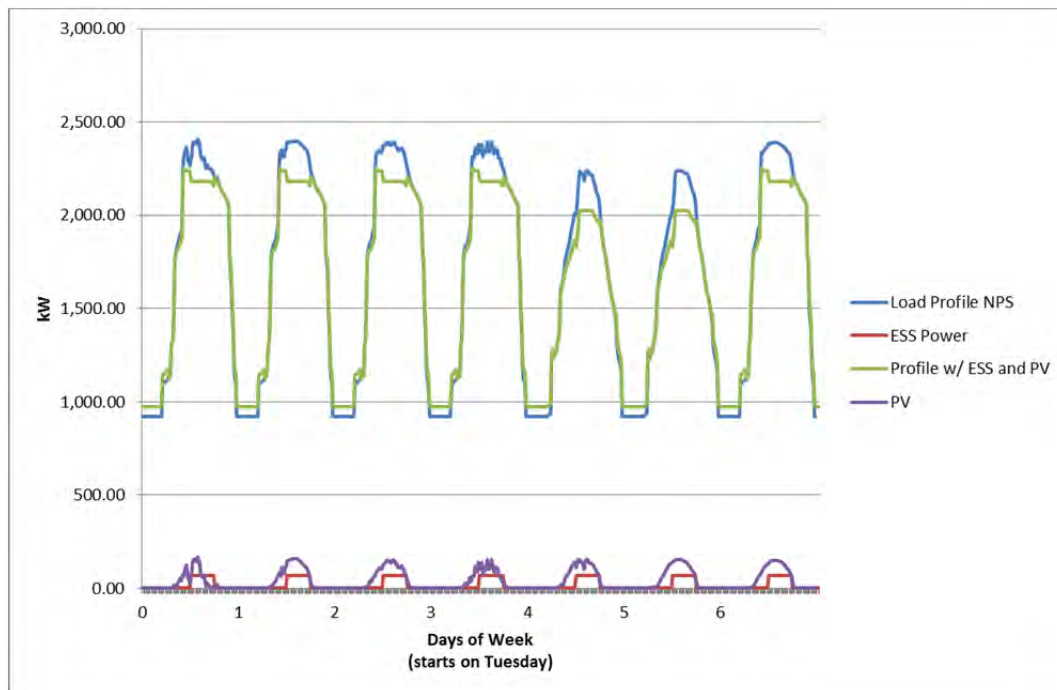

Figure 3. Load profile for the NPS campus with PV resources and an ESS.

The load profile with the use of an ESS and PV resources shows a higher energy usage during off-peak time periods and this is due to the battery charging at night from the grid. The battery was charged at a slower rate than discharge, but this was only done as there is a longer off-peak period available to charge the battery. The profile shown in Figure 3, has a peak that occurs during the partial peak rate period (0830–1200). If the partial peak spike had been reduced to the flat line that is shown for the peak time period (1200–1800), it would result in a savings of over \$400 for the month, but would also come at a cost of either a larger ESS or less power available for peak shaving during the peak rate period. The battery was modeled at 85% round trip efficiency.

The cost analysis for a 29 day bill period is broken down into two main billing components, demand and energy. The demand charge is a flat rate of \$/kW for the highest power during any 15-minute interval and is broken down into three different chargeable rates (peak, off-peak, and partial peak). The energy charge is also broken into the three different time periods and charges a different rate (\$/kWh) for energy consumed during each time period. The comparison of costs in Table 1 shows that there is a decrease in maximum peak demand which occurs during the peak power hours, but maximum demand remains the same as it is the maximum peak across all three time periods. As mentioned earlier, this scenario did not have the ESS discharging to cut-off all peaks during the day; it was only discharged to reduce the peak during the highest rate time period.

Table 1. Summary of NPS profile with an ESS and without a PV array.

	Normal Bill	Bill w/ ESS	Bill w/ no PV
Max Demand	\$22,442.47	\$22,442.47	\$24,049.77
Max Peak Demand	\$37,951.86	\$37,202.22	\$40,669.92
Partial Peak	\$7,855.99	\$7,855.99	\$8,316.53
Peak Energy	\$43,438.63	\$42,320.44	\$45,534.60
Partial Peak Energy	\$32,093.69	\$32,093.69	\$32,663.34
Off Peak Energy	\$42,664.69	\$43,419.18	\$43,353.30
Total	\$164,004.87	\$162,891.52	\$170,537.70

The peak shaving conducted with the ESS results of a savings of around \$1100 per month. With an approximate installation charge of \$1.4 million for a max peak 200 kW battery bank, the ESS will never come close to being cost effective during its lifetime.

The idea of using peak shaving is straightforward and fairly simple; store energy during time periods when the energy cost is minimal and discharge energy when the cost is at a maximum. This will definitely result in an energy cost savings for peak energy and likely for peak demand, but due to the large installation costs of an ESS and the relatively small difference for peak and off-peak energy prices at the industrial rate, it does not result in an overall cost savings.

Energy security is a worthwhile and important goal for the DOD both at the installation and operational level and utilizing an EMS with an ESS can achieve this goal at both levels, however the cost associated with ESS installation currently makes it cost prohibitive at installations that have power rates similar to the PG&E E20 industrial rate. For operational uses, using an EMS and an ESS is easier to justify because the goal is overall energy savings not overall cost savings. The energy savings in the operational environment can also translate to saving service members' lives and that is impossible to quantify in dollars.

REFERENCES

- [1] Assistant Secretary of Defense for Operational Energy Plans and Programs, "Operational Energy Strategy: Implementation Plan," Department of Defense, Washington DC, 2012.
- [2] IEEE, "IEEE Guide for Design, Operation, and Integration of Distributed Resource Island Systems with Electric Power Systems," IEEE std 1547.4-2011, IEEE, 2011.
- [3] R. L. Kelly, "Optimizing gas generator efficiency in a forward operating base using an Energy Management System," M.S. thesis, Naval Postgraduate School, Monterey, CA, 2013 Available: <http://hdl.handle.net/10945/34686>.
- [4] N. J. Peck, "Peak power control with an energy management system," Naval Postgraduate School, M.S. thesis, Monterey, CA, 2013, Available: <http://hdl.handle.net/10945/32884>.
- [5] Sandia National Laboratories, "DOE/EPRI 2013 Electricity Storage Handbook in Collaboration with NRECA," Sandia National Laboratories, Albuquerque, NM, 2013.

ACKNOWLEDGMENTS

I sincerely appreciate the help, guidance, and patience that my two thesis advisors, Dr. Oriti and Dr. Julian, gave me during the writing of this thesis. They provided expert knowledge and demonstrated the ability to explain complicated technical matters in terms that I could better understand.

I thank my wife, Brenda, for her patience, understanding, and gentle cajoling for me to “just get done.” I thank my kids for their understanding of my time spent away from home.

THIS PAGE INTENTIONALLY LEFT BLANK

I. INTRODUCTION

A. BACKGROUND

The Department of Defense (DOD) has recently taken great interest in its energy consumption across all facets of the organization and implemented several organizational goals and strategies to reduce the risk associated with its high energy usage. One of the goals of the DOD strategy is to improve energy security at fixed installations [1]. Currently the majority of energy used on fixed installations is provided via the commercial electric grid. This makes the DOD reliant on the commercial entities that control that grid for its own energy security. One of the main means for reducing that dependency is to develop microgrids on the installations that utilize distributed energy resources to power the installation or key infrastructure on the installation.

Microgrids are Distributed Resource (DR) island systems that consist of DRs and critical and non-critical loads, the ability to be connected to or disconnected from area Electric Power Systems (EPSs) (i.e., the commercial grid) and are intentionally planned [2]. The DR island system must be able to disconnect from and parallel with the area EPS. DR refers to any sources of electric power that are not directly connected to the main electric grid and includes electric generation and storage systems. DR refers both to nonrenewable generation systems such as microturbines, gas turbines, internal combustion generators and renewable generation systems such as photovoltaic (PV) arrays and wind turbines. The microgrid could either include the entire installation or portions of the installation. The Secretary of the Navy (SECNAV) has set the ambitious goal of having 50% of Department of Navy installations be net-zero installations by 2020, which assuming they meet the other criteria for DR island systems, would make half of all Navy installations their own microgrids [3].

Microgrids offer the main advantage of achieving energy security for DOD installations by ensuring critical infrastructure that is not dependent on the commercial grid for energy distribution. The other advantages are that it can improve the power quality, reduce total harmonic distortion (THD) at the loads, and allow for maintenance

of the area EPS while providing power to critical loads. The installations' ability to island may also help the commercial grid, by reducing load demand when required to prevent overload problems.

With the other DOD energy mandates, executive orders, and SECNAV goals, not every installation will be able to utilize DR to island the entire installation. Without building their own cogeneration plant or using microturbines, most installations cannot produce enough energy with the renewable DR available to them. For a smaller installation like the Naval Postgraduate School (NPS), there just is not enough physical space to place PV arrays or wind turbines to produce enough energy to be able to island the installation. The installation then looks to achieve the SECNAV goal of receiving over 50% of its energy from renewable resources by contracting with energy companies that generate energy from renewable resources. This still makes the installation dependent on the commercial grid for energy distribution, however.

Installations that do not have the ability to island the entire facility can still use DRs to create microgrids around critical infrastructure. Most installations already have generators installed to provide power to critical infrastructure in emergencies. Most of these do not meet the definition of a DR island system or microgrid as they are not able to operate in parallel with the area EPS and are for emergencies only.

The DOD has invested money in power electronics-based Energy Management Systems (EMSs) for expeditionary operations and that same technology could be used to create microgrids on installations [4]. The Marine Corps has funded two different prototypes for its Medium Hybrid Expeditionary Energy System (MHEES) that offer roughly the same functionality as the described EMS, but are much more ruggedized and meant for plug and play expeditionary operations [5]. The MHEES mainly focuses on energy efficiency by selecting the most efficient DR to power the load. The MHEES idea is to be able to utilize already fielded generators, expeditionary PV arrays, and energy storage systems (ESSs) to reduce generator fuel consumption by having the MHEES intelligently select the best combination to source the load. The EMS that will be discussed in this thesis is a digitally controlled power electronics unit that can interface

with multiple DRs and the area EPS to improve fault detection, reliability, peak power shaving, power factor correction, and efficiency.

B. OBJECTIVE

The objective of this thesis is to prove that by utilizing an EMS an installation can provide energy security for critical infrastructure, while using peak shaving to reduce costs and provide improved power quality. The EMS model that is going to be used is based on the work done in previous thesis research at NPS and will incorporate an ESS as well as the photovoltaic system that is currently installed at NPS [6], [7]. The contribution of this thesis is in establishing whether an ESS, as part of a microgrid, is worth the initial investment in terms of energy security, functionality, and cost savings.

C. RELATED WORK

The DOD and specifically the U.S. Army and U.S. Marine Corps have recognized the significant impact that energy usage has on their operations and their ability to conduct sustained expeditionary operations. In austere environments, power is normally produced via generators and those generators require fuel. That fuel not only places a logistical burden on the organization, but its distribution is directly tied to service members lives and hence there has been a large effort to become more efficient in energy usage. This effort has resulted in distributed generation (DG) in the form of expeditionary PV arrays and ensuring that generators are being used efficiently. Previous NPS thesis work has shown that with an EMS and energy storage in the form of a battery bank, fuel consumption can be significantly reduced at a Forward Operating Base [6].

Locations with an unreliable power grid or other commercial grid issues have invested in establishing their own microgrids in order to achieve energy security [8]. The DOD has also invested in several large projects to provide distributed generation and microgrids at installations where it either makes economic sense or is required for energy security. One of the largest of these types of projects is a Joint Capabilities Technology Demonstration (JCTD) project between the Department of Energy, DOD, and Department of Homeland Security called Smart Power Infrastructure Demonstration for

Energy Reliability and Security (SPIDERS) [9]. Sandia National Laboratories lists the objective of SPIDERS as:

The objective of the SPIDERS JCTD is to demonstrate that microgrids developed using Sandia’s Energy Surety Microgrid (ESM) methodology have the ability to maintain operational surety through secure, reliable, and resilient electric power generation and distribution to mission critical loads. The results of the SPIDERS JCTD will help inform infrastructure investment decisions needed to reduce the “unacceptably high risk” of extended electric grid outages. [9]

D. THESIS ORGANIZATION

A microgrid analysis is discussed in Chapter II to demonstrate the various components of the analyzed microgrid. This includes the PV arrays that are installed on the rooftops of three separate buildings on the NPS campus. These PV arrays have electronic monitoring that provides 15-minute data that is analyzed to show how this could be incorporated into the microgrid utilizing the EMS. Possible ESSs along with their main uses are analyzed for use in a microgrid. A sample load profile is also shown for the NPS campus.

In Chapter III, the EMS functionalities are examined to demonstrate how they can conduct peak power shaving and achieve islanding mode. In Chapter IV, a scenario demonstrates that utilizing the EMS and an ESS can load level and achieve some cost efficiency while providing greater energy security for the installation. The batteries needed to accomplish uninterrupted critical load operation and peak power shaving are discussed in Chapter V.

II. MICROGRID ANALYSIS

A. INTRODUCTION

A microgrid is an EPS that has the ability to disconnect from and run parallel to the area EPS (usually the commercial grid) [2]. It is made up of distributed resources, loads, and the distribution system. In this chapter, a microgrid will be analyzed by looking at the components that could make up a microgrid on the NPS Campus. They will include the PV arrays that have monitoring capability on the rooftops of three campus buildings, several energy storage options, and a digitally controlled EMS.

B. PHOTOVOLTAIC ARRAYS

As part of the SECNAV energy goals, Navy Region Southwest had several PV arrays installed on the academic buildings on the NPS campus. Three of these arrays had monitoring capability installed as part of the acquisition contract. The monitoring is available via an Internet site that is hosted by ABB Ltd and provides real-time energy metrics for each of the arrays. The site shows power output reported every 15 minutes from the arrays as well as historical data on different energy and environmental metrics.

NPS has a total of 187.4 kW of solar PV cells installed on top of three academic buildings that are monitored and provide real time 15-minute data via a web-based service. There are other solar panels installed at NPS that provide at least an additional 87 kW of solar PV capacity; 12 kW of which is grid tied with an inverter and 75 kW which is installed, but is offline waiting for an interconnect agreement. The data for those arrays was not readily available and was not used as part of this study [10]. The three arrays that were evaluated are located on Buildings 234, 245, and 339. All three arrays use Sharp 216 Watt PV modules with Sunlink[®] racking. The Sharp 216 Watt multipurpose module, or ND-U216C1, has an advertised efficiency of 13.25% at Air Mass (AM) 1.5, where AM 1.5 is the standard test conditions that best represent the spectral power distribution when the sun's radiation on earth is not directly overhead [11]. Testing the efficiency and other characteristics of the array was outside the scope of this thesis.

All arrays use a Satcon[®] PVS-75 inverter that provides three-phase power to the local distribution system with an advertised power factor (PF) greater than .99 and frequency range between 59.3 and 60.5 Hz at a nominal range of 208 VAC to 480 VAC [12]. Two of the arrays have an actual output of 280 VAC and one array of 480 VAC with less than 3% variation for all three arrays for the 90 days evaluated from 04/01/2014 - 06/30/2014. The inverter has an integrated Maximum Power Point Tracking (MPPT) system that would operate similarly to the system shown in Figure 1 to maximize solar power output for a given insolation. The angle control and magnitude control with Pulse Width Modulation (PWM) are designed to regulate active and reactive power to a reference of zero. The specification sheet lists the PF at full load of greater than 99% efficiency and with less than 3% THD for this inverter.

The actual operation of the MPPT embedded in the Satcon[®] inverter is proprietary, but the company advertises that it “increases PV plant kWh yield by extending the production window of arrays, enabling them to operate at optimal voltage and current levels for longer periods of time” [12]. The MPPT at its most basic level tracks the resistance value that will result in maximum power for the given I-V curve based on insolation and temperature. The load I-V curve shown intersecting the PV array I-V curve is shown in Figure 2. The PV cell is a controlled-current source with a non-linear I-V relationship that changes based on the conditions [11]. This inverter is a power conditioning unit that withdraws the maximum real power from the PV array without injecting any reactive power back into the grid. The maximum efficiency of this inverter is 96.7% including some losses that it would not have if the power was being supplied as DC power (to a battery bank for example). Power is being supplied to the local grid in a form that knocks off peak power during the highest rate time of use period (1200–1800 hours).

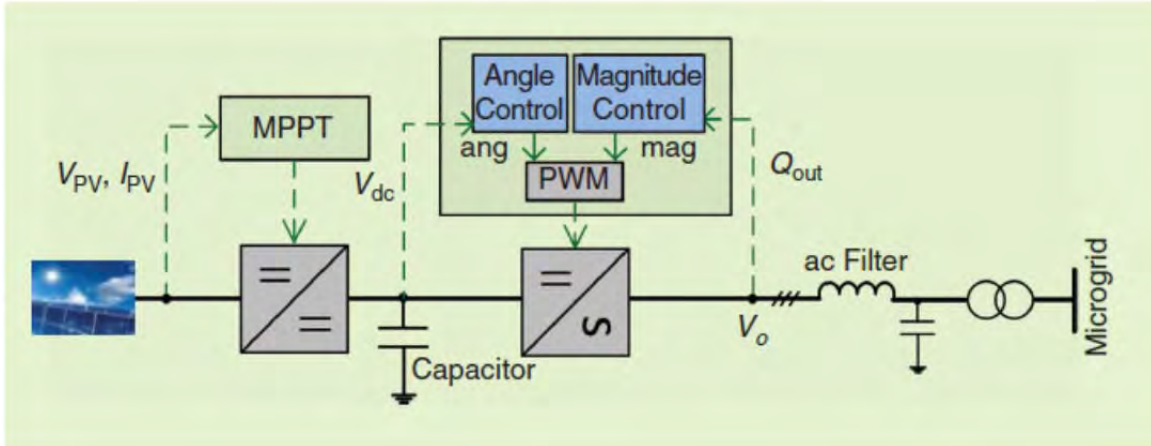

Figure 1. MPPT algorithm embedded in a PV inverter, from [8].

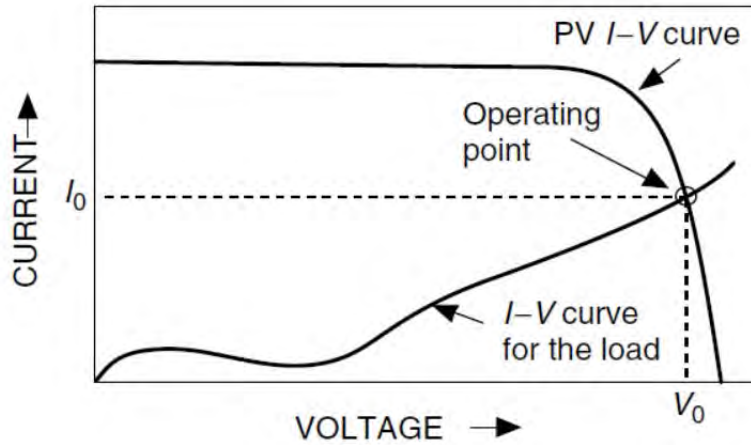

Figure 2. Simplified operating point for load and PV array, from [13].

C. ENERGY STORAGE SYSTEMS

A major challenge of utilizing PV arrays for distributed generation is how to utilize energy storage to provide energy when there is no power generation. This is especially relevant when there is power generation that exceeds the load during certain times of the day. This may happen if PV arrays are being used to power a relatively small load, as might be the case in an expeditionary or remote location. In that case, the PV arrays can be used with the EMS to charge the energy storage device with the excess power during the day and then use the energy storage device during times when there is no power generation to power the load.

This is not the case for the simulated microgrid analyzed at NPS, as the power generated by the PV arrays never approaches the load, as demonstrated in Figure 3. The load profile shown in Figure 3 will be described in more detail later in the chapter, but it is a representative load of NPS based on historical data and a PG&E power bill [14]. The PV arrays alone could never be used to provide an islanding capability for an installation with energy usage as high as NPS. With the space available at NPS and the theoretical maximum efficiency of PV cells, it would be impractical to attempt to utilize PV arrays combined with any sort of energy storage to power the entire installation [11]. A more feasible solution to islanding the entire facility would be to use a cogeneration plant or multiple micro turbines to provide a cost-effective means of generating power for the installation.

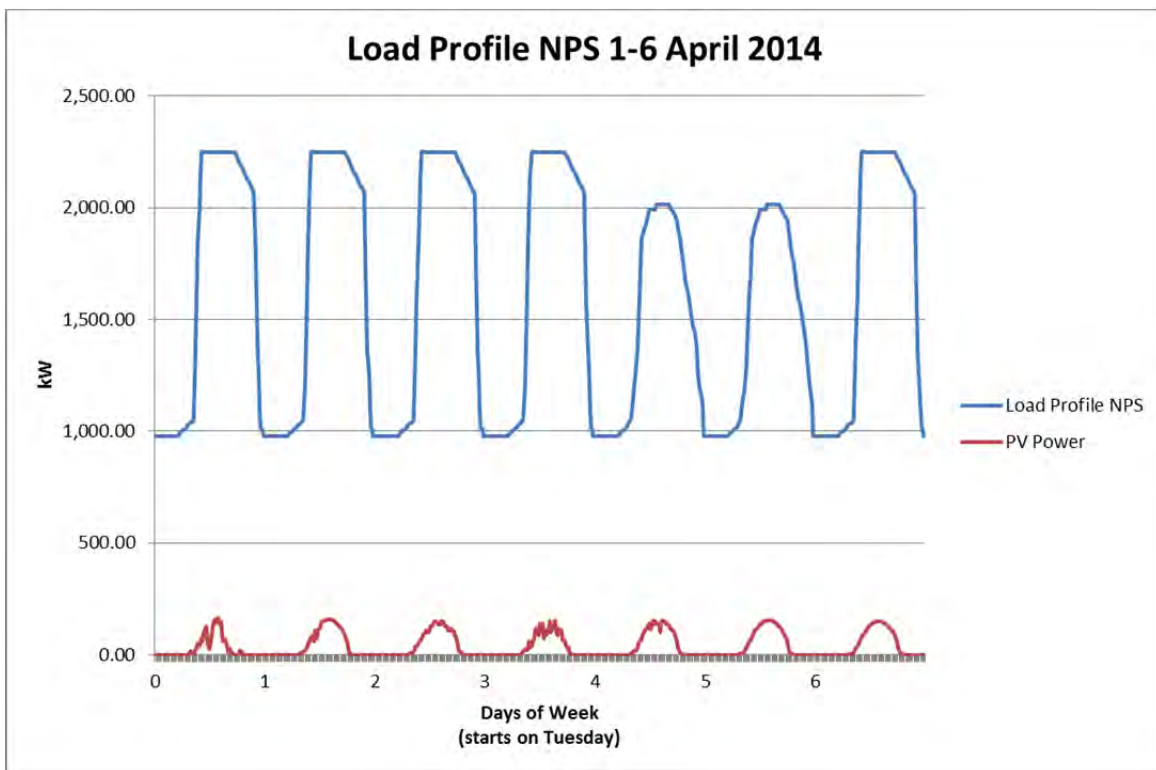

Figure 3. Sample load profile for the NPS with actual PV power ratings for the same time period, after [14].

Energy storage can be utilized with an EMS to conduct peak power shaving for an installation or it could be used in combination with distributed generation to provide

power for critical infrastructure. There has been much research and work conducted to improve the efficiency of energy storage devices. There is no one energy storage device that will meet every application, as the energy storage device needs to match the desired rated power along with the discharge time. An illustration of various energy storage devices with broad categories of function is shown in Figure 4.

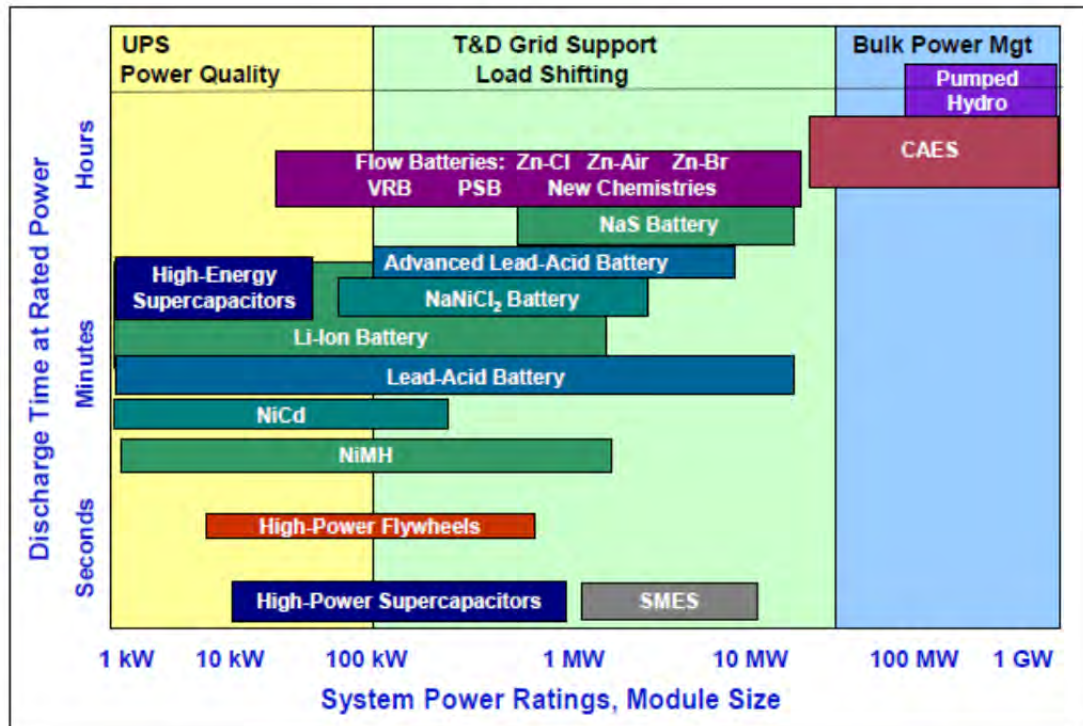

Figure 4. Discharge time and system power ratings for various energy storage technologies, from [15].

1. Chemical Batteries

The most common and well-known energy storage device is the battery. Batteries exist in many different forms and technologies and the specifications vary widely based on the energy density of the different battery types. The costs of the batteries also vary significantly based on the technology used and the desired specifications. Different battery technologies are compared in Figure 5 along with pumped hydro and flywheels.

The chart presented in Figure 5 demonstrates that even within a battery type there is a significant variation in rated power and discharge time.

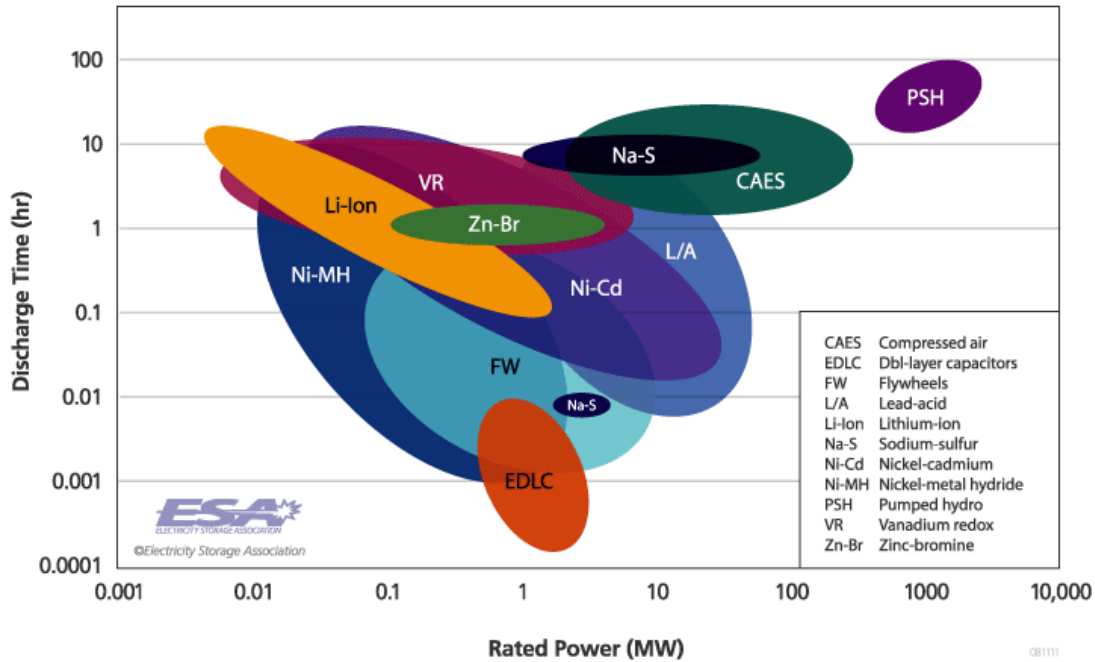

Figure 5. Discharge time and rated power for battery technologies, from [16].

a. Lead Acid Battery

Although there have been significant improvements in other battery types, the lead acid battery is the most commonly available for commercial distributed generation purposes. This is mainly due to the cost; although lithium-ion batteries have a higher energy density, they are currently not as cost effective as lead acid batteries for static purposes. There have been several advances in the recent past and there continues to be a great deal of research in making batteries more efficient, lighter, and safer; so it is expected that the norm for energy storage will eventually switch away from lead acid technologies. Currently the majority of commercially available high capacity deep discharge capable batteries for applications less than 1 MW are lead acid batteries [17].

A typical lead acid battery configuration is shown in Figure 6, although there are several variations and improvements that increase both the specific power and ability to

deep discharge the battery. Lead acid batteries typically have a lifespan of 3–15 years and that lifespan is highly dependent on the discharge cycle of the battery [17]. Deep discharge of a battery will seriously degrade the lifespan of a battery, so the manufacturer may recommend an optimal discharge of 50% or less. There are batteries manufactured specifically for renewable energy storage solutions however, and deep-cycle lead-acid (DCLA) batteries are already being used in battery banks that provide backup and peak shifting power for grid-tied microgrids [18]. DCLA battery banks could be used for large scale energy storage, but due to the large size, weight, and relatively low energy density, they are not as feasible for large-scale applications as they are for smaller applications.

Advanced lead acid batteries are batteries that have improved capability through either placing carbon in the electrodes or using carbon-doped cathodes, granular electrolyte retention systems, high-density positive active material, or silica-based electrolytes [15]. The advanced lead acid batteries have vastly improved capability, but that also comes at a much higher cost, so the majority of lead-acid battery banks are based on a variation of the tried and true technology that has been around for decades.

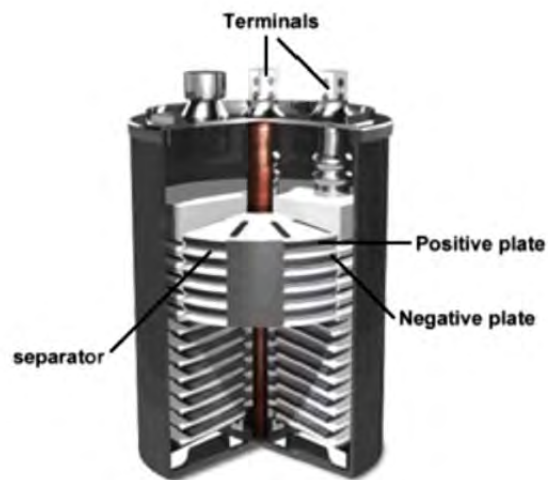

Figure 6. Lead acid battery configuration, from [17].

b. Flow Battery

Another electrochemical battery that shows great promise for energy storage is the flow battery that stores the active chemicals in external tanks. The flow batteries have

quick response time and have as much electrical storage capacity as can be stored in the external tanks. As can be seen in Figure 4, the flow batteries are firmly in the Energy Management realm with power potential of up to 10 MW [15].

The Vanadium reduction and oxidation battery (redox) is the most commonly known type of flow battery. Cells are constructed of a proton exchange membrane that allows the flow of ionic charge from the redox reactions of the vanadium to complete the circuit. The flow battery can typically go from zero output to full output in milliseconds to seconds and with the electrolyte stored in external tanks these systems are used on large scale projects (MWh). The external tanks contain both the anolyte and catholyte and use pumps to quickly create a reaction as shown in Figure 7, but for short duration discharges it is possible to get voltage out from just the electrolyte contained in the stack [15].

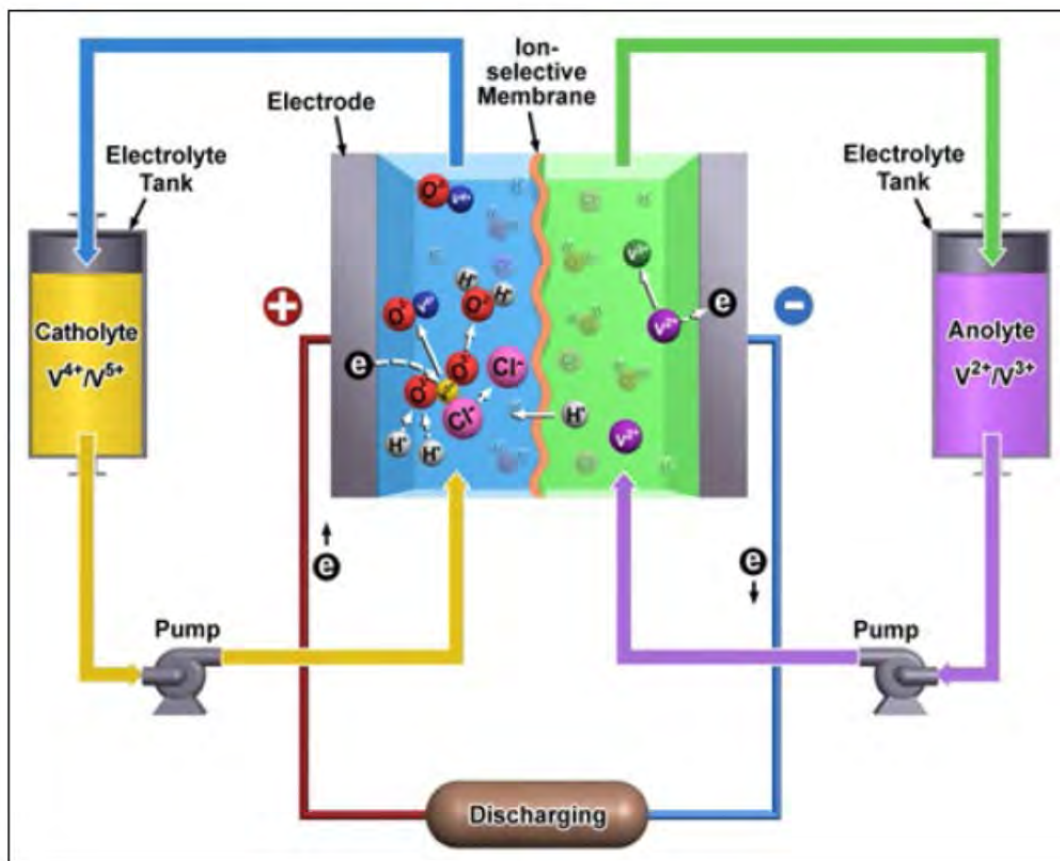

Figure 7. Vanadium redox battery, from [15].

c. Lithium Ion Battery

There are several projects that use lithium ion (Li-ion) battery banks with wind farms and grid power stabilization as well as commercial companies claiming that they can use Li-ion battery banks in residential situations for energy arbitrage [18]. Lithium ion batteries are probably best known for their use in electric and hybrid cars, but due to their high energy density they may become attractive as an energy storage option when their price point comes down. A company called SolarCity has partnered with Tesla batteries and is advertising 6–8 year payback on investment for purchasing a solar system (with energy storage) as well as lease agreements and power purchase agreements for residential customers in specific regions [19]. It is not possible to validate their claims for return on investment, but it is worth noting that they have decided on using Li-ion battery banks as an effective and efficient ESS.

Similar to some of the other chemical batteries, the electric current is carried by the flow of electrons in the external circuit and the flow of ions in the circuit. The porous membrane or separator shown in Figure 7 is generally a conductive salt solution. Lithium-ion batteries do have some safety concerns highlighted by several well publicized reports of fires due to these batteries [20]. With the popularity of electric cars and the announcement that car manufacturer Tesla is going to build a large factory devoted to building Li-ion batteries and driving down costs, Li-ion batteries have some of the largest expected growth potential across a wide scale of energy storage uses [21].

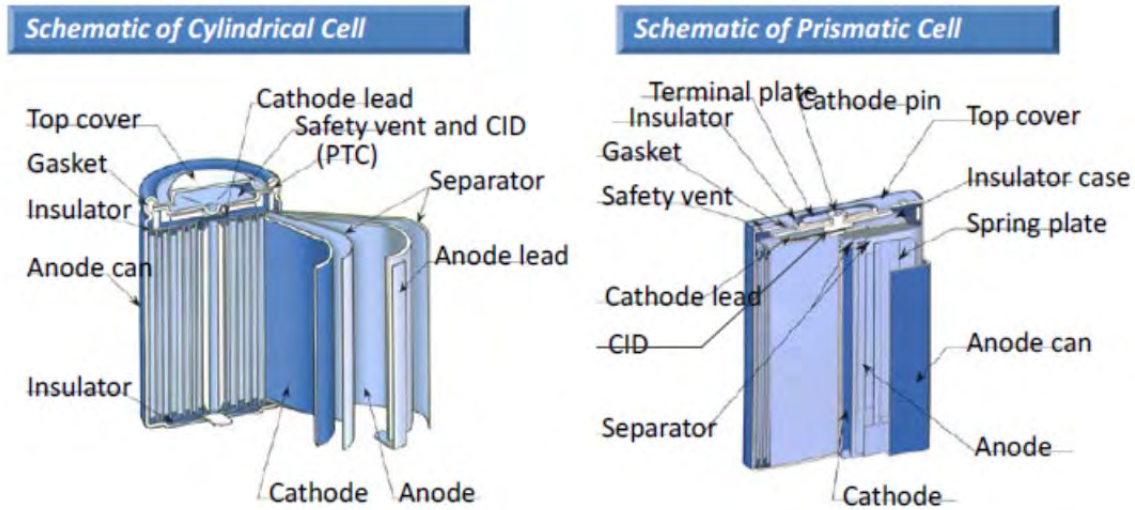

Figure 8. The two most common lithium ion cell topographies, from [15].

d. Sodium Nickel Chloride Batteries

Sodium nickel batteries are a relatively mature technology that have the large advantage of being able to operate in a large temperature range and do not require the same cooling systems that other batteries do. When charging the battery, the NaCl and Ni are transformed into NiCl_2 and Na; these reactions reverse during discharge. The electrodes are separated by an electrolyte that is conductive for the sodium ions, but isolates the electrons [15]. The porous cathode is located in the liquid sodium anode as shown in Figure 9 and the sodium ion salt provides a conductive path for the electrons and current collector.

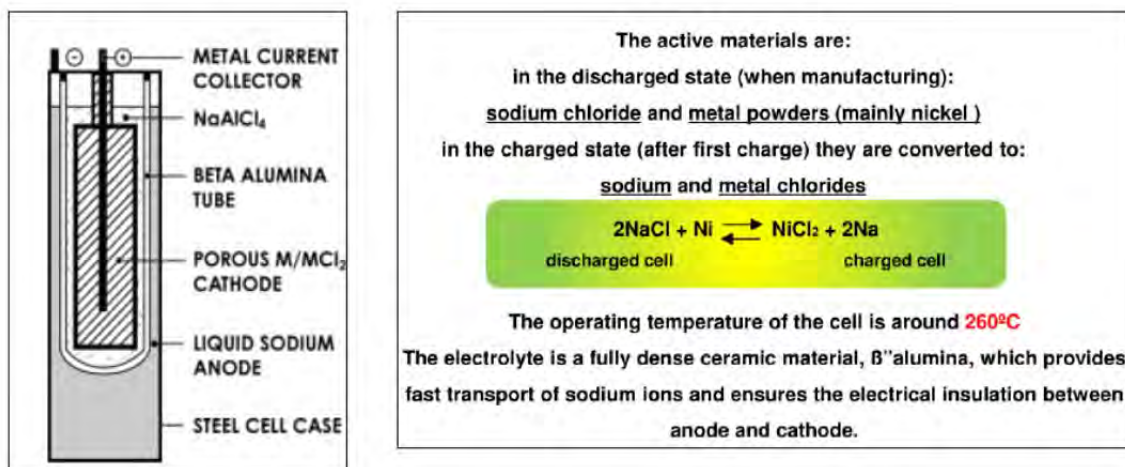

Figure 9. Sodium nickel chloride battery with description, from [15].

There are at least two suppliers that have full-scale production of these batteries on the 50kW to 1MW range [15]. The data sheet in Appendix A is for a General Electric Durathon Battery that utilizes this technology. That data sheet was used as a general reference for the simulated ESS described later as it is modular in size and designed to be integrated into a generic microgrid situation. According to the manufacturer, there is also no need to oversize the battery bank, as must be done with lead-acid batteries due to battery degradation and depth of discharge issues and this simplifies sizing the battery bank. They also have a similar price point as lead-acid batteries.

2. Fuel Cells

Fuel cells convert chemical energy contained in the fuel into electrical energy. The most common fuels used are: hydrogen, natural gas, methanol, propane, and gasoline [13]. Although fuel cells are generally categorized as a generation system and not a storage device, depending on how they get their fuel they can be used in a combined capacity. The main advantage of a fuel cell is that it can achieve theoretical fuel-to-electric efficiencies as high as 65%, which is almost twice as high as any fuel-to-electric power station operating today [13]. Since a fuel cell can be placed very close to the load that it is powering there are less transmission losses. If the fuel cell is used as a cogeneration system and the waste heat is used for space heating or hot water then the

overall efficiency of the system is increased. Another method to improve the overall efficiency and reduce environmental impact is to power the fuel cell using hydrogen obtained by electrolysis of water from a renewable energy source.

The basic set-up for a Proton Exchange Membrane (PEM) fuel cell is shown in Figure 10. There are many different types, but they all require an anode, cathode, and an electrolyte. The electrolyte conducts positive ions, but not electrons or neutral gases. The type of electrolyte can differentiate the type of fuel cell. In Figure 10, the fuel is hydrogen and it breaks into electrons and protons in the electrolyte. The protons diffuse to the right through the electrolyte and the electrons are drawn up to the load as they try to reach the cathode [13]. This results in a current from the cathode to the anode.

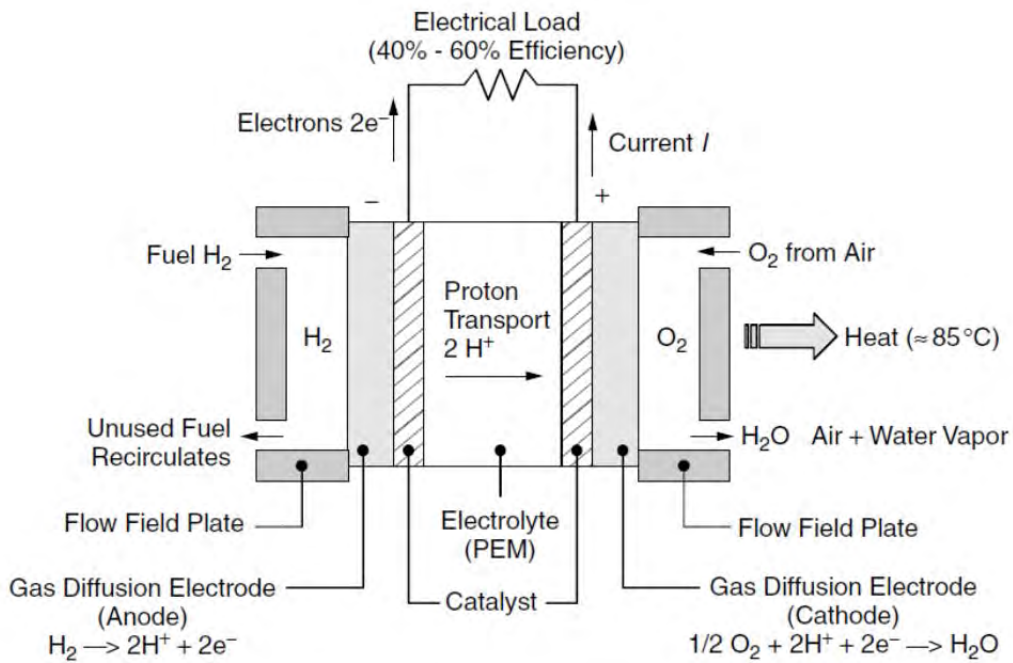

Figure 10. PEM fuel cell, from [13].

3. Flywheels

Flywheels store energy as kinetic energy and can have efficiencies of close to 100% for electrical storage and in the 80–90% range during power transfer [22]. Since flywheels can be made to be tremendously efficient and can be sized to the desired

energy storage amount, in concept they are a very attractive alternative. They have high density levels of power and energy and their total cost does not grow linearly with power and energy demand. Since flywheels rotate a few thousand revolutions per minute to above 50,000 revolutions per minute, there are safety concerns involved with the use of flywheels. Steps have been conducted to mitigate the risk of failure, but those additional steps also increase the total system cost.

Flywheels have been demonstrated to be an effective energy storage device in electrical railway applications (where they can store energy from a regenerative braking event or provide energy for acceleration). Using a flywheel driven by an electrical machine, the system operates either as a motor or generator and is connected to the electrical network through power electronics equipment that controls voltage and frequency levels. This power electronics equipment is a form of an energy management system although its main focus is either absorbing or providing power to the electrical system through voltage and current controls [22]. Large flywheels combined with power electronics and control strategies have been examined as an effective means of maintaining constant frequency through variable loads and intermittent sources in the commercial power grid [23].

4. Other Energy Storage Devices

There are several other energy storage devices that are currently being used and some that are being researched. Nickel-cadmium batteries have been used on a small scale for rechargeable devices and have also been considered for PV generation because they can withstand high temperatures [17]. For large-scale applications sodium-sulfur (NaS) batteries have been used successfully. Compressed Air Energy Storage (CAES) technology is mature, and recent technological advances have increased its potential for large scale energy storage with several CAES projects in active development [23]. Currently pumped hydro has the largest capacity of the U.S. market with over 95% of the rated power for grid storage projects [23]. Since pumped hydro is geographically limited and used for larger applications it was discarded as an option for this study.

The Department of Energy (DOE) is currently tracking and investing in all of the ESS technologies shown in Table 1.

Table 1. DOE energy storage technologies, after [23].

Technology	Primary Application	Known	Challenges
Fly wheels	<ul style="list-style-type: none"> • Load leveling • Frequency regulation • Peak shaving and off peak storage • Transient stability 	<ul style="list-style-type: none"> • Modular technology • Proven growth potential to utility scale • Long cycle life • High peak power without overheating concerns • Rapid response • High round trip energy efficiency 	<ul style="list-style-type: none"> • Rotor tensile strength limitations • Limited energy storage time due to high frictional losses
Advanced Lead-Acid	<ul style="list-style-type: none"> • Load leveling and regulation • Grid stabilization 	<ul style="list-style-type: none"> • Mature battery technology • Low cost • High recycled content • Good battery life 	<ul style="list-style-type: none"> • Limited depth of discharge • Low energy density • Large footprint • Electrode corrosion limits useful life
NaS	<ul style="list-style-type: none"> • Power quality • Congestion relief • Renewable source Integration 	<ul style="list-style-type: none"> • High energy density • Long discharge cycles • Fast response • Long life • Good scaling potential 	<ul style="list-style-type: none"> • Operating Temperature required between 250° and 300° C • Liquid containment issues (corrosion and brittle glass seals)
Li-ion	<ul style="list-style-type: none"> • Power quality • Frequency regulation 	<ul style="list-style-type: none"> • High energy densities • Good cycle life • High charge/discharge efficiency 	<ul style="list-style-type: none"> • High production cost - scalability • Extremely sensitive to over temperature, overcharge and internal pressure buildup • Intolerance to deep discharges
Flow Batteries	<ul style="list-style-type: none"> • Ramping • Peak Shaving • Time Shifting • Frequency regulation • Power quality 	<ul style="list-style-type: none"> • Ability to perform high number of discharge cycles • Lower charge /discharge efficiencies • Very long life 	<ul style="list-style-type: none"> • Developing technology, not mature for commercial scale development • Complicated design • Lower energy density
SMES	<ul style="list-style-type: none"> • Power quality • Frequency regulation 	<ul style="list-style-type: none"> • Highest round-trip efficiency from discharge 	<ul style="list-style-type: none"> • Low energy density • Material and manufacturing cost prohibitive
Electrochemical Capacitors	<ul style="list-style-type: none"> • Power quality • Frequency regulation 	<ul style="list-style-type: none"> • Very long life • Highly reversible and fast discharge 	<ul style="list-style-type: none"> • Currently cost prohibitive
Thermochemical Energy Storage	<ul style="list-style-type: none"> • Load leveling and regulation • Grid stabilization 	<ul style="list-style-type: none"> • Extremely high energy densities 	<ul style="list-style-type: none"> • Currently cost prohibitive

5. Energy Storage System for Simulation

In this section, the NPS microgrid is simulated with an ESS that has a maximum power of 50 kW and energy storage of 100 kWh. As described above, there are several energy storage options that could be utilized to achieve this. A lead-acid deep cycle battery bank is utilized here with an estimated average cost of \$500/kWh for the total system cost. This includes the ESS costs (combination of power and energy ratings), the power conversion system costs (everything connecting the energy storage device to the grid including the power conditioning unit, transformers, and control systems), and the balance of plant costs (construction, taxes, permits, and fees). The data provided in Figure 11 was utilized to validate the cost. Using the maximum power of 50 kW and energy storage of 100 kWh and (1), it was determined that the total equipment cost is between \$29,100 and \$109,000. This partially validates the \$500/kWh estimate that gives a total system cost of \$50,000. This is in line with other articles that indicate for a lead-acid battery system the energy required (kWh) is more important than the maximum power required (100 kW). In Equation (1), P_{\max} is the power capacity of the system in kW, C_{BOP} is balance of plant costs, C_{PCS} is power conversion system costs, C_{PC} is energy capacity costs, E_{\max} is energy capacity of the system (kWh) and C_{EC} is energy capacity cost (\$/kWh) [24].

$$C_{\text{cap}} = P_{\max}(C_{\text{BOP}} + C_{\text{PCS}} + C_{\text{PC}}) + E_{\max}C_{\text{EC}} \quad (1)$$

There are several different methods for estimating the cost for energy storage as well as the cost for energy generation systems. The method used above is pulled from a variety of sources, but it should be noted that the DOE estimates are much higher than that listed above. They break down the energy usage by function and use different metrics to estimate capital costs and various leveled costs for energy. The DOE's estimate for the present value of \$/kW installed cost is between \$4200 and \$12000 per kW [15]. The main difference in the calculations is that the DOE estimate also includes financing requirements. There is a large difference in the estimates, but it is not crucial to this study as the savings shown by installing an ESS with an EMS never approach either of the estimate values.

		Chemical Storage							
		Conventional Battery			Molten Salt Bat.		Flow Battery		
		LA	NiCd	Li-ion	NaS	ZEBRA	ZnBr	PSB	VRB
Techno. Params.	Roundtrip Efficiency [%]	70-82	60-70	85-98	70-90	85-90	60-75	57-75	60-85
	Self-discharge [%Energy/day]	0.033-0.3	0.067-0.6	0.1-0.3	0.05-20	15	0.24	≈0	0.2
	Cycle Lifetime [cycles]	100-2k	800-3.5k	1k-10k	2.5k-2.5k	2.5k	2k	2k	12k-14k
	Expected Lifetime [Years]	3-20	5-20	5-15	5-15	10-14	5-10	10-15	5-15
	Specific Energy [Wh/kg]	30-50	50-75	75-200	150-240	100-120	30-50	10-50	10-30
	Specific Power [W/kg]	75-300	150-300	150-315	150-230	150-200	0	0	0
	Energy Density [Wh/L]	50-80	60-150	200-500	150-250	150-180	30-60	16-60	16-33
	Power Density [W/L]	10-400	0	0	0	220-300	0	0	0
Costs	Power Cost [\$/kW]	175-600	150-1500	175-4000	150-3000	150-300	175-2500	330-2500	175-1500
	Energy Cost [\$/kWh]	150-400	600-1500	500-2500	250-500	100-200	150-1000	120-1000	150-1000
	BOP Cost [\$/kWh]	120-600	120-600	120-600	120-600	120-600	120-600	120-600	120-610
	PCS Cost [\$/kW]	58-180	50-180	0	0-120	0-120	0-120	60-120	36-120
	O&M Fixed Cost [\$/kW-y]	1.8-52	6-32	12-30	23-61	23-61	15-47	18-96	24-65

Symbol	Technology
PHS	Pumped Hydroelectric Energy Storage
CAES	Compressed Air Energy Storage
FES-LS	Low Speed Flywheel Energy Storage
FES-HS	High Speed Flywheel Energy Storage
CAP	Standard Electrostatic Capacitor
ECC	Electrochemical Capacitors (supercapacitors)
SMES	Superconducting Magnetic Energy Storage
LA	Lead Acid Battery
NiCd	Nickel-Cadmium Battery
Li-ion	Lithium-ion Battery
NaS	Sodium-Sulfur Battery
ZEBRA	Sodium Nickel Chloride Battery
ZnBr	Zinc-Bromine Flow Battery
PSB	Polysulfide-Bromide Flow Battery
VRB	Vanadium Redox Flow Battery

Figure 11. Summary of costs of chemical energy storage devices, from [24].

D. LOAD PROFILE AND ENERGY COSTS FOR NPS

Figure 3 shows a sample load profile for NPS that was simulated from historical data on yearly usage, a PG&E power bill (Appendix B), and metered data from other naval installations. All the major buildings aboard NPS have power meters that provide 15-minute data to a central hub, but that data is currently not available for evaluation so a load profile was created that simulated an average 7-day period. There are spikes in an actual profile and other variations that are not taken into account, but the goal was to show that reducing the peak power can reduce costs. If the profile used actual data that had more pronounced spikes and variations in the load, this would improve the argument for using an EMS and energy storage device to reduce electricity costs. The power bill demand charge is based on the highest peak demand during the entire billing cycle [25].

NPS has a time of use (TOU) agreement with PG&E that places them in the Industrial Service Rate customer group for a maximum demand of over 1,000 kW. The E-20 rate is designed for customers whose maximum demand exceeds 1,000 kW for at least three consecutive months during a 12-month period [25]. The rates change almost quarterly and PG&E maintains a website that has the current rates and previous rates back to 2001 or when that particular type of service became available if it was after 2001.

All of the TOU rates have a summer and winter rate that are further broken down into a demand charge and an energy charge [25]. There are several other charges included in the bill, but as they do not change based on the load profile, they were not considered for this study. The PG&E bill that was utilized to assist in developing a load profile and for simulating results based on changes in that profile was from 2/18/2014–3/18/2014 and covers two different PG&E rates. The document is included as Appendix B. The rate changed on 3/01/2014, so the power bill and excel sheet that replicates the load are broken down into two time periods (2/18/2014 – 2/28/2014) and (3/01/2014–3/18/2014). NPS also receives a considerable “generation credit” from PG&E, \$72,797.54 for the 29 day billing period evaluated, because naval installations actually purchase the power from Western Area Power Administration (WAPA). Therefore, the power bill evaluated is for transmission and distribution from PG&E, not for power generation. The power purchased from WAPA is generated from hydroelectric dams and counts towards the SECNAV goal of 50% of power from renewable resources.

To create the load profile, a spreadsheet simulation was created that used 15-minute data with the PG&E rates to give a cost for the 29 day billing period [14]. The 15-minute data was adjusted from an estimated baseline and used the PG&E maximum power demands for the two separate time periods. The adjustments were made using linear modifiers to adjust the profile until it closely matched the PG&E bill for demand and energy charges. The profile was iteratively adjusted until it was within 2% of the actual costs for the PG&E bill.

The simulated load profile for one of the NPS buildings, Ingersoll Hall, from 04/01/2014 – 04/07/2014 is shown in Figure 12. The dates had to be adjusted from the bill period used as there was not data available for one of the PV arrays during that time

period. The profile for Ingersoll Hall was created by taking 7% of the total NPS load profile (based on 2011 data provided by NPS installation Energy Manager). The NPS profile was first adjusted to what the load would be without the PV arrays. The load profile was then adjusted by utilizing the PV array from the three reporting systems along with a simulated ESS that conducts peak shaving during Max Peak Energy Time of Use periods. The profile shows that with the PV array and an appropriately sized ESS, that the peak load profile could be reduced by 25% without even maximizing the ESS. This would be important in an islanding scenario where the back-up generators would have to pick-up the load currently being provided by the grid. If the generator was not large enough to source the entire load it would need to have built-in logic that would allow it to load shed and power the critical loads.

If only the energy reduction cost due to the ESS is taken into account for the profile shown in Figure 12, there would be a savings of approximately \$225 for the 29-day billing period evaluated. At that rate and excluding Operations and Maintenance (O&M) costs it would take 18.6 years to achieve return on investment for the ESS. That is well past the expected 10-year lifespan for the majority of the battery-based energy systems [17]. The profile shown is more of an example of how an ESS could be used in conjunction with other distributed generation to form a microgrid than as an example of a cost saving method. It will also be discussed in the next section that it is possible that the ESS could be augmented by or replace the necessary UPS for the data center.

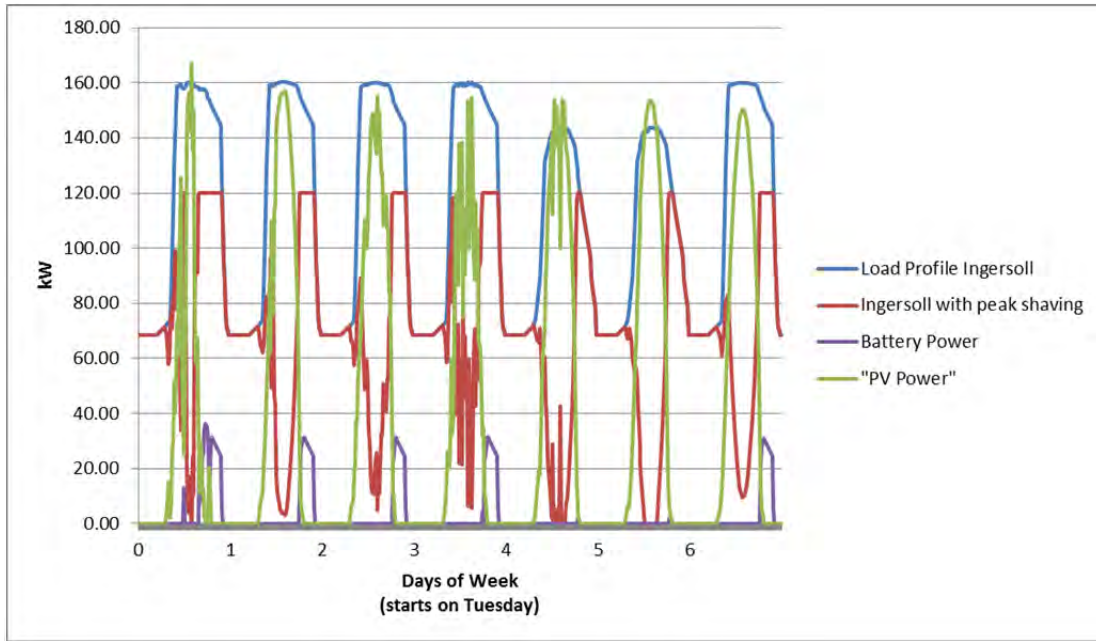

Figure 12. Simulated load profile for Ingersoll Hall, 04/01/2014–04/07/2014, after [14].

E. CRITICAL INFRASTRUCTURE

To create a microgrid that can operate in islanding mode out of the entire NPS installation either requires significantly more distributed generation than NPS has or a larger than desired energy storage system. So, instead of looking to island the entire facility, the goal is to create a microgrid around critical infrastructure. Critical infrastructure could be anything that the installation deems critical for daily operations, but some examples would be:

1. Command Operation Centers
2. Data centers
3. Security facilities and communications infrastructure
4. Public Works buildings vital to daily operations.

Ingersoll Hall houses academic offices, classrooms, the Information Technology and Communications Services (ITACS) office, and a data center. Since data centers are

vital to an academic institutions' mission, they are generally identified as critical loads and have special protections associated with them.

Data centers normally have Uninterrupted Power Supply (UPS) as a requirement to ensure that information is not lost in the event of a power interruption. Generally, these UPS requirements are relatively short-term as they are only intended to power the data center until the back-up power (normally a generator) is able to turn on. This could be in the range of seconds to a few minutes. Advances in power electronics and ESS may allow for the ESS and UPS to be used in conjunction in some applications to conduct peak shaving and load leveling or to completely combine the ESS with the UPS for the data center [26]. The determination for how they are used is largely influenced by the specifications of the ESS used and how quickly it can react to a power disruption. UPS can be used as an ESS to support grid stability and conduct peak shaving as long as the minimum backup energy for the data center remains guaranteed. The next generation UPS may very well just be part of the ESS that is designed for reducing cost via peak shaving.

The advantage to using the ESS as the UPS for a required critical load is that cost effectiveness is no longer the driving factor. The UPS is required to perform a critical function and must be purchased; utilizing it also as an ESS to perform that function can contribute to additional cost savings. The simulated profile for Ingersoll Hall with an ESS powering a critical load is shown in Figure 13. The challenge for a DOD installation is justifying the additional set up cost of establishing the system with an EMS. One of the justifications is that the EMS provides energy security in the form of resiliency by being able to utilize the PV array during a grid disruption. For routine operations the cost savings would be similar to the profile shown in Figure 12, but the more significant energy savings would come in the event of a long term grid disruption when the installation was able to utilize the power coming from the PV array. Those costs are more difficult to calculate as the savings would include fuel saved to run the generators that currently power the critical load during power loss [6].

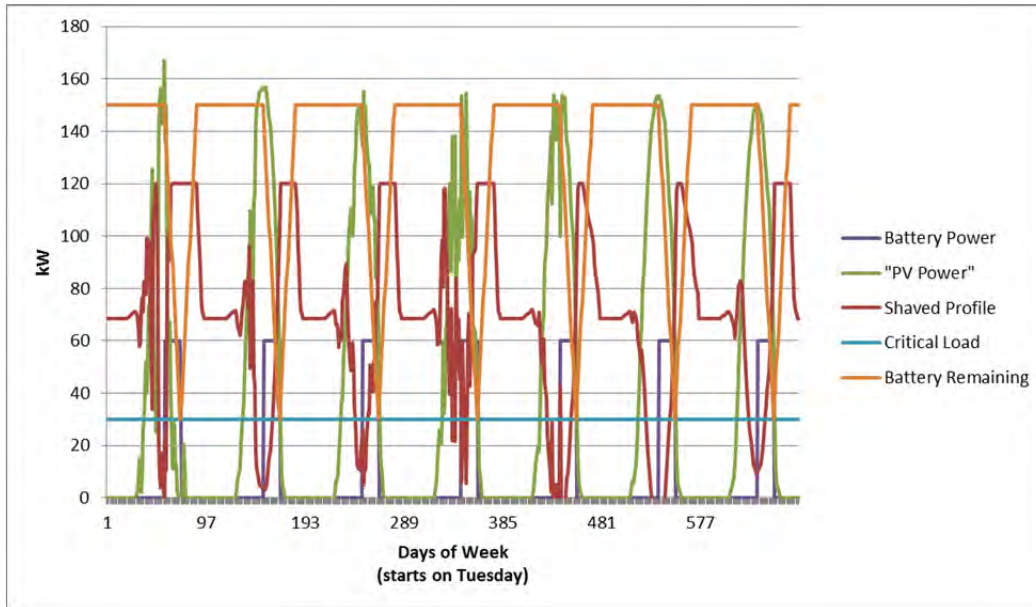

Figure 13. Ingersoll Hall profile with critical load shown and a 150 kWh battery.

There are currently diesel generators that provide back-up power for several of the buildings aboard NPS and the data center in Ingersoll Hall. If there is a power failure aboard NPS, the diesel generators will automatically turn on by design to provide power to the buildings they are connected to. Since the generators are not controlled by an EMS and do not operate in parallel with the commercial grid, they do not technically constitute a microgrid. Ideally these generators could be controlled by an EMS to conduct peak power shaving and power quality management, but current California State Environmental Protection Agency restrictions only allow them to be run for minimal times [7]. Running the diesel generators would also be counter to the DOD's goals of reducing greenhouse gas emissions at all of its installations [1]. In emergency situations, the generators could be utilized though, so it would make sense to incorporate them into any envisioned EMS for critical infrastructure and utilize them in islanding operations when there is a power disruption.

THIS PAGE INTENTIONALLY LEFT BLANK

III. ENERGY MANAGEMENT SYSTEM

A. INTRODUCTION

In this chapter, EMS functionality, possible hardware, and implementation strategies are presented. As shown in Figure 14, the EMS provides an interface between the critical and non-critical loads and DRs (energy sources and ESSs) as well as interacting with the commercial grid and receiving its control input from the user. An EMS could be installed at the commercial grid level and focus more on frequency regulation and maintaining power quality or it could be used for energy efficiency in selecting the most appropriate DR for the given critical loads [6], [26], [27]. The functionality explored in this chapter is the ability of the EMS to utilize DRs to reduce peak power demand.

The EMS functions can include peak power management, uninterrupted power supply to critical loads, DR source selection, and selective load shedding [6], [7]. The EMS can also be set to automatically switch into islanding mode given a loss of power from the commercial grid. On the commercial level, utility companies are creating what is being known as the smart grid that is designed to automatically detect and correct issues with power transmission and distribution [15]. This can include injecting reactive power closer to the load to correct power quality issues or using energy storage systems to maintain the desired electrical frequency. There are also several commercially available products designed for households that have PV arrays and energy storage systems installed.

B. EMS FUNCTIONALITY

Previous NPS thesis work [6], [7] has shown through laboratory experiments and simulated results that an EMS using Field Programmed Gate Array (FPGA) controlled logic can:

- 1) load shed based on programmed logic for critical and non-critical loads,
- 2) load level or reduce peak power demand by utilizing energy storage device (battery),
- 3) power source selections based on real-time power demand, the ESS state of charge, and the distributed generation available,
- 4) island the systems when main AC grid has a disruption, and
- 5) use the ESS to supplement power in order to maintain maximum generator efficiency [6], [7].

The EMS has previously been considered mainly for islanding mode operations with its own power generation and ESS along with identified critical and non-critical loads. The EMS can also operate with the commercial grid operating in place of a distributed generation resource as shown in Figures 14 and 15. In this capacity, the EMS is designed to utilize the available distributed generation and ESS to most economically power the load mainly through peak shaving. This also has the advantage of providing grid stabilization through reduced peak power demand [26].

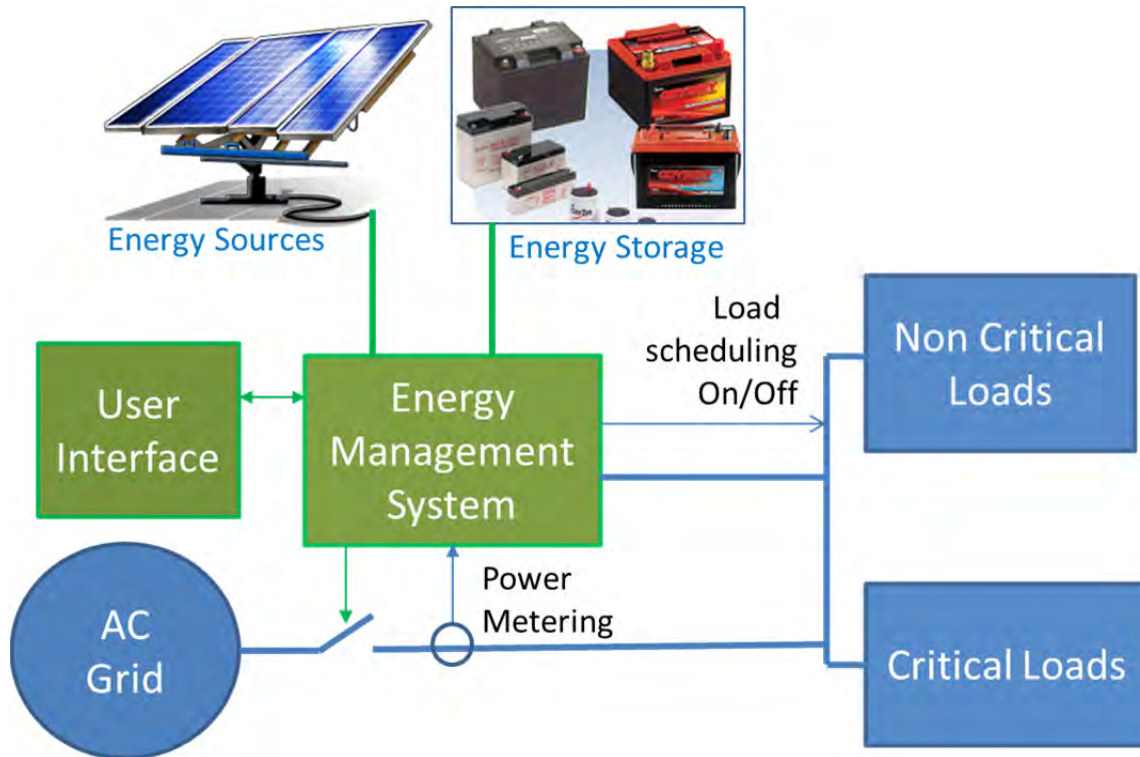

Figure 14. Diagram of EMS functionality.

Figure 15 shows the EMS architecture used to demonstrate its functionality. It should be noted that this EMS uses a single phase system as opposed to a three-phase system that would be needed to connect to the simulated microgrid from Chapter II. It is possible to use a single phase inverter for grid interface, but if the EMS was to be tied into the PV arrays that are already set-up it would need to also be able to run in three phase mode. The EMS shown includes an ESS in the form of a battery and a single phase voltage source inverter which can be controlled either as a voltage or current source. The ESS is modeled as the voltage source v_{batt} in the diagram and is connected to the buck-boost leg of the inverter to create bidirectional power flow to and from the battery [27]. The critical loads are shown as connected to both the AC power grid and the AC voltage created by the EMS and will always receive power from one or the other grid systems. The non-critical load can be shed by the EMS via a thyristor switch if the applied logic dictates to drop the load. That would generally happen in a situation where the EMS was

in island mode and the battery power was not sufficient to power both critical and non-critical loads.

The EMS has a primary and secondary control system that dictates how power flows in the grid that it is a part of. The primary control system is defined by the power converter module controllers that use reference voltages and currents controllers to generate the gate drive signals [27]. The secondary control system is user driven by deciding depth of discharge for battery, load priority, and commercial grid energy rates. The secondary control system feeds the primary control systems and dictates when the battery gets charged and discharged and could be utilized to decide which distributed generation system to utilize for which loads and when.

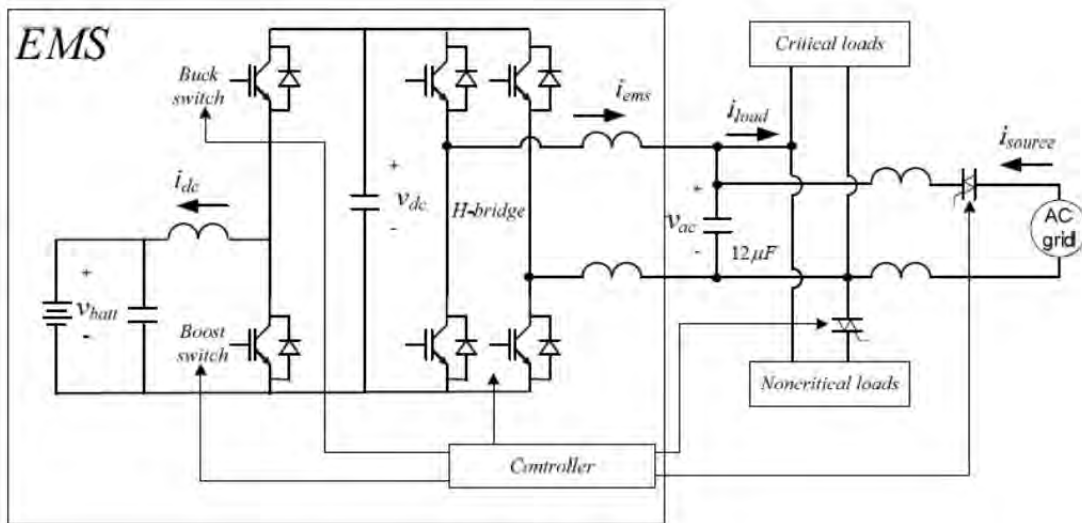

Figure 15. EMS schematic, from [27].

When the EMS is operating connected to the AC grid it is able to operate as a current source and can provide reactive power by changing the electrical angle of the current (i_{ems} shown in Figure 15). This allows the EMS to provide real or reactive power as scheduled and could be used to correct power factor issues in the grid [27].

Although reactive power is tracked and an installation's PF can contribute to either cost or credits (for PF above .85) it is minimal compared to the other costs, so PF correction would only be implemented for the efficiency of the grid and not cost. For reference, the bill in Appendix B shows a cost of \$21.87 for a Power Factor Adjustment of 48,599 kWh. On the bottom of the bill it shows the metered data of 41,442.72 kVAh for reactive power. Using $S^2=P^2+Q^2$, then $S=63,869.5$ VAh and with PF equal to active power divided by reactive power or .76 for this situation. The power factor adjustment for the bill is (the difference of the PF as a percentage and 85%) times \$.00005 per kWh [25]. For this bill that is 9 times 48,599 kWh times \$.00005 equals \$21.87. For a \$20,000 bill and a poor PF, the penalty is only about .1% of the bill. The most the installation could have received in credits for a unity PF would have been \$36.44. So although it is possible to utilize the EMS to conduct PF correction, it is currently not a cost-driven goal.

To charge the battery the controller will schedule current into the DC bus by the H-bridge (i_{ems} shown in Figure 15) and the circuit will operate in Buck mode, charging the battery with the scheduled DC current. When the EMS is operating off the battery, the DC bus controller is operating in Boost mode and is providing current (i_{ems}) to the AC bus through the H-bridge [27].

1. Peak Shaving

To achieve peak shaving a value has to be set in the controller, so that when the load RMS current exceeds the set limit, then the EMS starts providing some of the current by pulling from the battery. The EMS will provide whatever current is scheduled so long as the load RMS current exceeds the limit, once the load current drops below the limit, the EMS will either stop providing power or start charging the battery, as it has been programmed to do [7].

2. Uninterrupted Power to Critical Loads

One of the primary functions of the EMS is to provide uninterrupted power to the critical loads in the event of a power disruption on the main grid causing the EMS to island the system [6]. Depending on the size of other available DRs and the ESS charge, the EMS may also have to conduct load shedding to achieve this. An example of this

could be the described microgrid in Chapter II with the data center as the critical load. If a power disruption happened when there was no PV generation to power other loads and the ESS only had enough power to act as an UPS for the data center then it would drop all other loads and just power the critical load. The EMS opens the thyristor switch connected to the non-critical loads to achieve this function (thyristor connecting non-critical loads in Figure 15). The secondary control system can be programmed to connect the EMS back to the grid and provide power to the non-critical loads once the power disruption is cleared [27].

The controller will establish a threshold for the AC bus so that when voltage dips below that threshold the EMS will open the thyristor connecting to the AC grid putting the system in islanding mode. There will be a slight unavoidable delay in the fault detection that establishes island mode and safeguards will also have to be put in place to ensure unintentional islanding does not happen. In any EMS, there will be challenges to ensure seamless transition between operating off the commercial grid and running on island mode. The system will have to be designed so that the delay in switching between modes is acceptable and that any variation in voltage or current during or immediately after switching does not disrupt critical loads.

C. CONCLUSION

The EMS has tremendous functionality for microgrid applications as well as for energy savings in military expeditionary operations. For microgrid applications the ability to detect a fault from the grid, disconnect, and then automatically switch to DR is crucial to be able to service any critical loads. The ability to determine critical loads is also important as there may not be enough power available to service all loads immediately after a grid disruption. The functions of an EMS are vital to the operation of any microgrid including its ability to island when necessary and conduct peak shaving when it is connected to the grid.

IV. A SAMPLE SCENARIO USING THE EMS FOR PEAK SHAVING

Utilizing the same load profile described in Chapter II, the functionality of peak shaving is shown with an added ESS and an EMS type device. A cost analysis will also be conducted for peak shaving for the entire installation. A key component for the DOD in selecting energy related projects is the cost effectiveness. So although energy security may be a valuable and worthwhile goal, it still needs to be cost effective.

A DOD Inspector General (IG) report concluded that the DON used American Recovery and Reinvestment Act (AARA) funds for 12 PV projects and will not recover \$25.1 million of the \$50.8 million invested. The IG report lists several references that state that PV projects and energy projects in general must be cost effective. One of these projects financed by the AARA funds referenced was the installation of the three PV arrays on the top of the academic buildings at NPS. The cost of that project was \$2.6 million and the IG report indicates that about 19% of that cost will be recoverable in energy savings [28].

The main issue between the justifications that were submitted for project approval and the IG report was Life-Cycle Cost Analysis (LCCA) differences. The differences in the LCCAs were mainly due to differences in cost of electricity and not accounting for degradation of performance of the PV system. It appears that the IG report does not account for peak power demand savings because they utilize a standardized rate for energy (\$/kWh), but that difference still would not make any of the systems cost effective [28].

The justifications for installing these systems were two fold, to achieve SECNAV energy goals and at the time of installation the submitted LCCAs were showing cost savings. As the installation now purchases its generated power from a renewable resource (hydro power via WAPA) and the IG report shows a net loss for the project, neither of those goals are achieved. The IG report also states that contributing factors to the approval of these projects even though they ultimately proved to be not cost effective

included the short deadlines and a general misunderstanding of permissible uses for AARA funds [28].

The PV arrays also can not be utilized during a commercial grid disruption because there is no EMS interface that allows them to and so they do not achieve any energy security goals either. Since energy security is an important goal and there is currently much discussion about its application in the DOD, the goal of this chapter is to look at the cost effectiveness of implementing a microgrid at NPS utilizing the PV arrays, an EMS, and notional ESS. The load profile discussed in Chapter II will be utilized to conduct peak shaving. Chapter II focused on using an ESS to power a critical load as a microgrid and showed that it would not be possible to be cost effective for that application. That scenario was examined with and without the PV arrays, so using the same scenario for the entire installation would not change the cost effectiveness of the system.

A. PEAK SHAVING USING THE EMS WITH 400 KWH STORAGE AND 200KW PEAK POWER ESS

In this scenario, we used an ESS that would be able to handle the maximum power of the solar arrays and have appropriate sized energy storage for that application. The ESS is modeled off the specification sheet in Appendix A for the GE Durathon battery and the LCCA and installed costs will be conducted using the DOE/Electric Power Research Institute 2013 Electricity Storage Handbook. The DOE handbook is used for the cost estimate as it has similar data for all known energy storage devices simplifying cost comparison. In this scenario, the goal is not to make a microgrid out of NPS, but to show the effect of peak shaving using an ESS.

The profile shown in Figure 16 is the NPS profile that was made using the 15 minute data for PV arrays and the peak power data for peak and partial peak time periods. The PV array data was taken for a 29 day time period starting on 06/01/2014 and the cost estimate was done using PG&E summer rates for the E20 service contract [14], [25]. The costs shown include power generation costs that NPS gets credits for as naval installation southwest does not buy power generation from PG&E, but as the data is for

comparison only it still reflects accurate savings. The profile shown in Figure 16 was made assuming that the battery would be charged during off-peak time periods and it was scheduled to be charged from 2200 until 0630 every day. This 8.5-hour charge time is the maximum amount of charge time required to meet full battery capacity if the battery was completely discharged. The battery discharges its energy during peak time periods (1200–1600) and the data shown is for a full discharge.

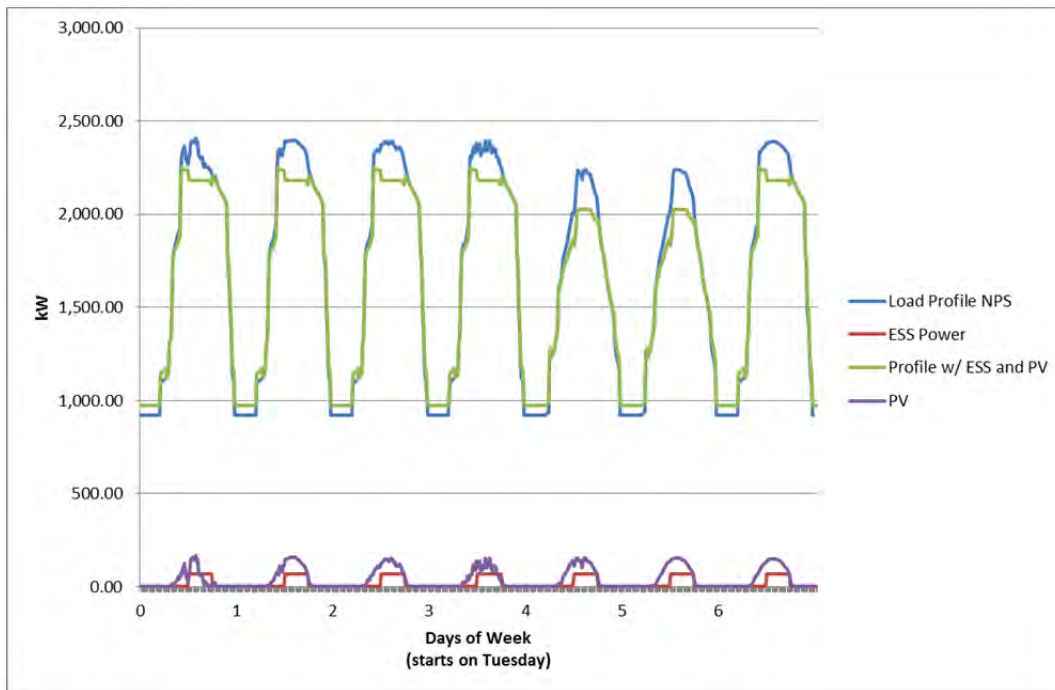

Figure 16. Load profile for the NPS campus with PV and ESS.

The load profile with the use of an ESS and PV resources shows a higher energy usage during off-peak time periods and this is due to the battery charging at night from the grid. The battery was charged at a slower rate than discharge, but this was only done as there is a longer off-peak period available to charge the battery. The profile shown in Figure 16, has a peak that occurs during the partial peak rate period (0830–1200). If the partial peak spike had been reduced to the flat line that is shown for the peak time period (1200–1800), it would result in a savings of over \$400 for the month, but would also come at a cost of either a larger ESS or less power available for peak shaving during the peak rate period. The battery was modeled at 85% round trip efficiency [13].

1. Battery Efficiency

Any conversion of energy is going to result in losses and one of the factors in selecting energy storage devices is the efficiency of the device in converting energy to its desired function. In this case, the battery is going to receive power from the grid as AC, store it as DC and then return it as AC power. Therefore, there will be conversion losses during energy storage and during discharge. The battery data sheet in Appendix A lists the roundtrip efficiency as 85% and this was modeled with 93% efficiency in the AC/DC conversion and 92% efficiency in the DC/AC conversion. There is an opportunity for energy savings utilizing an EMS if there are DC/DC applications for both charging and discharging. Examples of this are utilizing a PV array to charge an energy storage device and powering an LED lighting system from the energy storage device (or PV array).

Battery efficiencies can also change based on depth of discharge and environmental aspects (mainly temperature) as well as cycle rate. The battery efficiency may degrade based on life of the battery as well and this has to be factored into the LCCA [18].

Another method for modeling the conversion losses is to use the same charging and discharging rates, but to charge the battery for longer based on the expected conversion losses. To most accurately reflect the cost of the conversion losses, the losses were included as part of the rates for charging and discharging the batteries as they happened during different rate periods [15].

2. Cost Analysis

The PV arrays were not considered as a separate source during this estimate as the majority of their power output already occurs during peak power. Therefore, the NPS profile used included the peak shaving that already occurs from the PV arrays. The PV arrays were used to provide power to the ESS during non-peak hours and that cost savings came out to \$27 for the 29-day period. As this is inconsequential compare with a \$160,000 bill, it was excluded from the data shown. If it was possible to increase the efficiency of charging the batteries from the PV array that savings may increase to a point that it becomes relevant.

The cost analysis for a 29-day bill period is broken down into two main billing components, demand and energy. The demand charge is a flat rate of \$/kW for the highest power during any 15-minute interval and is broken down into three different chargeable rates (peak, off-peak, and partial peak). The energy charge is also broken into the three different time periods and charges a different rate (\$/kWh) for energy consumed during each time period. The energy rate is the more straightforward of the two rates as it is a sum of all energy used during the billing period broken down into three different time periods. The demand rate is more complicated as it also includes the generation charge for the energy and so although it is shown just as the demand rate on most bills; it is further broken down by the power company to include other costs [25].

For this analysis, the demand rate for PG&E's E20 industrial schedule is used; this does not represent an actual NPS power bill as there is no consideration for the generation credits it receives from buying its energy generation from WAPA. The figures given would be more representative of the energy bill if there were no generation credits and the installation did buy all its power from PG&E. The comparison of costs in Table 2 shows that there is a decrease in Max Peak demand which occurs only during the peak power period (1200–1800), but Max Demand remains the same as it is the maximum peak across all three time periods. This scenario did not have the ESS discharging to reduce peaks during the non-peak rate time periods and so the Max Demand charge remained the same for the first two scenarios shown in Table 2. The third scenario shown is representative of the cost if the PV array power was not installed and was made by using the PV array data and adding it back to the simulated load profile [14]. The Max Demand is the maximum power demand that occurs during any 15 minute interval during the entire billing cycle. For the billing cycle shown the Max Demand occurs during the partial peak time period from 0830–1200 and can be seen as the bump on the top of the load profile shown in Figure 16.

Although there are cost savings with using the ESS in this application, they are relatively minimal compared to the bill and compared to the cost of installing an ESS system. The estimate for an ESS of this size and based on the technology from Appendix A is taken from Figure 17 that shows an average cost of almost \$7000 per kW.

The variation in installed cost shown in Figure 17 is also similar to an installed cost from the same reference for a lead-acid ESS. The ESS used for this scenario was 200 kW at the average cost this would lead to an installed cost of \$1.4 million. The ESS in this scenario is only saving a little over \$1100 a month and could never possibly pay the installation cost of the system.

Table 2. Comparison of costs for peak shaving.

	Bill w/ PV no ESS	Bill w/ ESS and PV	Bill w/ no PV no ESS
Max Demand	\$22,442.47	\$22,442.47	\$24,049.77
Max Peak Demand	\$37,951.86	\$37,202.22	\$40,669.92
Partial Peak Demand	\$7,855.99	\$7,855.99	\$8,316.53
Peak Energy	\$43,438.63	\$42,320.44	\$45,534.60
Partial Peak Energy	\$32,093.69	\$32,093.69	\$32,663.34
Off Peak Energy	\$42,664.69	\$43,419.18	\$43,353.30
Total	\$164,004.87	\$162,891.52	\$170,537.70

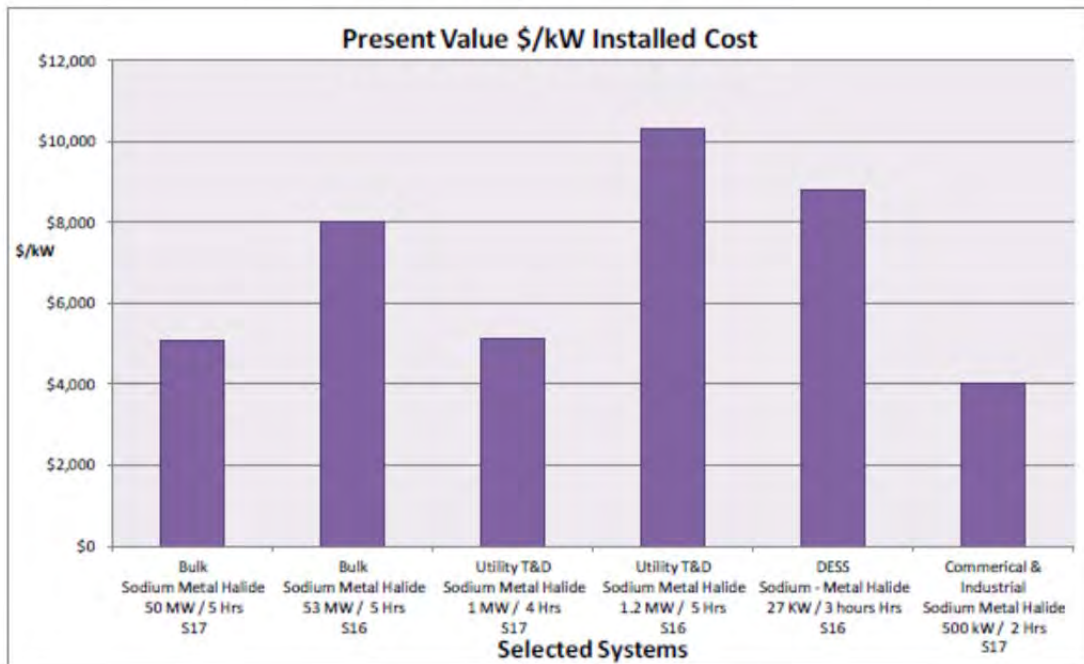

Figure 17. Installed cost for sodium-nickel-chloride batteries, from [15].

The installed costs used in Figure 17 include all equipment, installation, and interconnection as well as financing costs. Since a DOD application would not have a

financing tax associated, the costs could be reduced by 7.3% for the financing, but they would also need to be increased to include project planning costs that were not included in the estimate [15]. These costs may not match very closely to the actual cost, but it is also evident that installing an ESS for peak shaving in this application is not cost effective no matter what estimate method is used.

B. CONCLUSIONS

The idea of using peak shaving is straightforward and fairly simple: store energy during time periods when the energy cost is minimal and discharge energy when the cost is at a maximum. This will definitely result in an energy cost savings for peak energy and likely for peak demand, but due to the large installation costs of an ESS and the relatively small difference for peak and off-peak energy prices at the industrial rate, peak shaving does not result in an overall cost savings.

THIS PAGE INTENTIONALLY LEFT BLANK

V. CONCLUSIONS AND FUTURE WORK

A. CONCLUSIONS

Energy security is a worthwhile and important goal for the DOD both at the installation and operational levels and utilizing an EMS with an ESS can achieve this goal at both levels, however the cost associated with an ESS installation currently makes it cost prohibitive at installations that have power rates similar to the PG&E E20 industrial rate. For operational uses, using an EMS and an ESS is easier to justify because the goal is overall energy savings, not overall cost savings. The energy savings in the operational environment can also translate to saving service members' lives and that is impossible to quantify in dollars.

This study only considered the costs associated with integrating an ESS into a particular microgrid and did not look at other DR. Using microturbines and other natural gas cogeneration (energy and heat) power generation systems is a more affordable way of providing power for peak shaving on an installation. Although it was not proven in this thesis, the installation costs for combustion turbine (CT) or combined-cycle gas turbine (CCGT) are significantly less than energy storage and have been proven to provide cost savings at other installations [15]. Energy storage in any microgrid application may be difficult to justify from a cost savings point of view and should be examined to determine whether it is a required function before deciding on implementing it as part of the microgrid [26].

At the installation level, energy needs to be understood not just as a cost, but as a capability. If any DR system is purchased for the purpose of energy security than it needs to be able to provide power when there is a grid disruption. If we do purchase a relatively expensive system like a PV array, then we should ensure that the function of that system is being achieved, especially when it is unlikely that it has an effective life cycle cost. The general trend is that energy will continue to become more expensive and there may be additional charges for both demand and energy charges, especially during peak time periods. These trends may make PV arrays more attractive as they do decrease peak

energy and demand charges, but they will also need to be incorporated into a smarter system that is able to utilize the power provided when there is a grid disruption.

B. FUTURE WORK

This study mainly focused on incorporating an ESS using an EMS, but there are other interesting aspects of a microgrid that can be studied. There are multiple different control strategies for controlling both the power flow within the microgrid and also for its connection with the local EPS [8]. These control strategies may maximize cost savings by knowing the cost of producing energy from your own generation system. For an installation the size of NPS, this would likely require installing a centralized cogeneration plant that could be run when the utility-provided cost of power exceeded installation-provided cost of power.

There are also commercially available and government provided energy modeling tools that can be used to optimize the size of ESS and DR. The National Renewable Energy Laboratory (NREL) has a free model that requires knowledge of a programming language such as C++ to process the inputs [29]. The other software tools have large purchase prices, but could be worth the investment to investigate potential cost savings.

This thesis was not designed to be a model for how NPS could form a microgrid or even advocate for utilizing an ESS. NPS was used because there was data available for the PV arrays, the energy bills, and it was possible to create a simulated load profile. The installation does have the ability to provide actual 15-minute power data that would negate the need for a simulated profile, as the actual data could be used. There are currently contractor issues with retrieving that data, but future work could use that power usage data to show either improved functionality with an EMS or potential cost savings.

It will be difficult to achieve cost savings by utilizing an ESS alone. However, if it is paired with a requirement that it can provide its intended function and provide some cost savings, that will decrease the overall life cycle costs of the system. This could be the case for critical infrastructure that needs continuous power in the case of a grid disruption. The EMS has the proven capability to island a system when there is a power disruption; it would be useful to demonstrate that capability on critical infrastructure. An

example of this would be an entry control point at an installation. If an EMS was set-up to automatically pull power from a battery bank while the generator was starting up, the continuous power provided for a critical function may prove it is worth the cost.

The data centers are currently provided instant back-up power by a co-located UPS with enough power to either clear any faults with the generator start-up or properly shut down the data center without losing critical information. This is likely the most cost-effective method and also achieves the best functionality with the UPS designed to provide uninterrupted power, however as the data center power requirement increases it may require using an EMS with an ESS. It would be worth investigating whether the EMS can achieve the specifications necessary to operate a standard energy storage technology as a UPS.

One of the scenarios that was examined in this study was utilizing one building in conjunction with the PV arrays and an energy storage device to create a microgrid. From the profile shown, it is evident that another generation system is needed even to power one building as the power requirement is just too large. The installation has diesel generators as back-up power for some of the buildings that could operate in this capacity in an emergency, but a more efficient use may be to install microturbines that could be used on a daily basis to conduct peak shaving. An analysis could be conducted to consider the cost effectiveness of using microturbines to conduct peak shaving on a daily basis when connected to the grid and increase energy security by working with an EMS type system to provide power during outages. It would still be ideal to incorporate the PV arrays into the microgrid as otherwise their energy potential is wasted during power outages. This may be possible utilizing the microturbine idea and islanding each individual building. That way each building with PV arrays could be tied into that building's EMS (possibly requiring some ESS for any power provided over the building usage, but not likely).

A facility the size of NPS pays between \$45,000 to \$60,000 a month in distribution and transmission charges (no data was available for the size of the monthly WAPA bill for generation) and there are many different methods that could assist in using that energy efficiently. Due to the high cost of energy storage and relatively low

differential that NPS pays between peak power and off peak power it is not possible to implement energy storage as a stand-alone cost savings method. Energy storage does have positive attributes though and as the DOD looks to provide greater energy security for its bases, energy storage use inside of a microgrid will have to be analyzed to determine its function versus its cost.

APPENDIX A. DURATHON BATTERY DATA SHEET

GE Energy Storage

Durathon® Battery

Durathon DC System Technical Specifications – kWh Series

The Durathon DC System kWh Series is based on one or more 100 kWh Durathon Battery Enclosures paired with a Durathon Interface Enclosure, which acts as the hub for all system power and communications connections. To increase duration or energy capacity, the number of 100 kWh enclosures connected in parallel can be increased as needed. All specifications outlined below reflect the total requirements of both the 100 kWh Durathon Battery Enclosures and the accompanying Durathon Interface Enclosure.

Technical Data	DC100 kWh	DC200 kWh	DC300 kWh	DC400 kWh	DC500 kWh	units
Maximum Power	50	100	150	200	250	kW
Maximum Current	115	230	345	460	575	A
Operating Voltages:						
Maximum Recharge	577					V
Open Circuit	557					V
Discharge Termination	432					V
Power Delivery Capacity¹:						
2 hours	50	100	150	200	250	kW
3 hours	33.3	66.7	100	133.3	166.7	kW
4 hours	25	50	75	100	125	kW
5 hours	20	40	60	80	100	kW
6 hours	16.7	33.3	50	66.7	83.3	kW
Maximum Long Term² Recharge Power Acceptance¹:						
20% DOD	10	20	30	40	50	kW
50% DOD	32.5	65	97.5	130	162.5	kW
90% DOD	50	100	150	200	250	kW
Recharge Times (from full DOD):						
100% Maximum Power	8.4					h
Round Trip AC Efficiency ³	85					%
General Data						
Operating Ambient Temperature	-40 to 50 -40 to 122					°C °F
Altitude ⁴	1,000					m
Site Restrictions	Designed for indoor/outdoor installation					

¹ Values listed on beginning of life performance.
² Long term is defined as greater than previous discharge.
³ DC modules only. AC roundtrip efficiency estimated; assumes typical peak-shave application.
⁴ Without derating. Additional operating range is possible.



*Durathon is a trademark of General Electric Company.
 GE, the GE Monogram, Imagination at work, ecomagination and all other trademarks, and service marks, unless otherwise noted, are owned or licensed by General Electric Company or its subsidiaries. All other brand names, product names or trademarks belong to their respective holders.

Copyright © 2016, General Electric Company. All rights reserved.
 Specifications subject to change without notice. Please consult GE Energy Storage for the latest specifications for your application. Please refer to the Durathon safety brief for additional information.

General Data	DC100 kWh	DC200 kWh	DC300 kWh	DC400 kWh	DC500 kWh	units
Life:						
Cycle Life	4,500					cycles
Float Life	15					years
Dimensions²:						
Overall Height	2,438 96					mm in
Overall Depth	1,128 45					mm in
Overall Width	1,536 60	2,301 91	3,066 121	3,831 151	4,596 181	mm in
Weight	2,532 5,570	4,584 10,086	6,637 14,602	8,690 19,117	10,742 23,633	kg lb
Interconnect:						
Battery and Ground Terminals	Bus Bar					
Communication	Modbus TCP/IP, EGD					
Warm-up Power Requirements ³	7.5	15	22.5	30	37.5	kW
Auxiliary Power Requirements (AC) ⁴	1	2	3	4	5	kVA
Electrical Requirements	Grounded negative DC bus, Voltage ripple < 4 Vrms, External AC and DC overcurrent protection and disconnect (customer provided)					
Certification: Complete (as appropriate per model)	CE Marking, EMC/FCC/CISPR 22 Class A UL 1973 Seismic Zone 4 Outdoor enclosure rating to NEMA 3R					

²Dimensions are nominal
³Power from DC bus required. Warm-up period approximately 30-45 hours
⁴System auxiliary connection 480VAC single phase. Circuit size = 10-amp

Technical Drawings

From module to rack to system, the Durathon E620 Battery and DC System Series are designed for flexibility and expansion.



Figure 1. Durathon E620 Battery



Figure 2. Durathon DC100kWh System

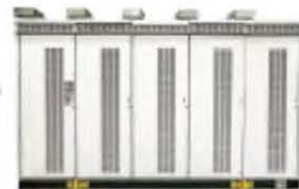

Figure 3. Durathon DC1MWh System



USA 9862303A

APPENDIX B. PG&E NPS POWER BILL

Bill Charges report

Page 1 of 2

Bill Charges report



Report Date 5/20/2014 1:02 PM
 Report Span 2/18/2014 - 3/18/2014
 Total Days 29

Customer: US NAVY

Service Provider Pacific Gas and Electric Company
 Account Number 87BCADCD-AAA3-4821-A44B-B7B14FE0A191
 Meter Number MONTEREY 1730955005 END OF MICHAEL J SMITH LN X64432 BM7DT-1
 Rate PGE - E-20P

Charges For Period 2/18/2014 - 3/18/2014

Charge Name	Quantity	Avg Price	Amount (\$)
<u>Demand</u>			
Demand Charge - E20P	1,500 kW	9.95	14,925.00
Subtotal Demand			14,925.00
<u>Energy</u>			
Energy Charge - E20P	48,599 kWh	0.08	4,068.43
PGE - State Energy Commission Tax	48,599 kWh	0.00	14.09
Power Factor Adjustment	48,599 kWh,kVArh	0.00	21.87
Subtotal Energy			4,104.39
<u>Fixed</u>			
Customer Charge - E20P			1,427.10
Subtotal Fixed			1,427.10
Total Charges For Period 2/18/2014 - 3/18/2014			20,456.49

Usage:

Determinant Name	Units	Quantity	Timestamp
PGE - Demand - SumWin OnPartOff - Winter - PartialPeak	kW	1,500.00	2/19/2014 10:00 AM
PGE - Demand - Summer/Winter All Hour - Winter - AllHours	kW	1,500.00	2/19/2014 10:00 AM
PGE - Energy - SumWin OnPartOff - Winter - OffPeak	kWh	28,814.40	
PGE - Energy - SumWin OnPartOff - Winter - PartialPeak	kWh	19,784.16	
KWH - Annual All Hours - Annual - AllHours	kWh	48,598.56	
KVARH - Annual All Hours - Annual - AllHours	kVArh	41,442.72	

Details of PG&E Electric Delivery Charges

02/18/2014 - 03/18/2014 (29 billing days)

Service For: CRNR BUTLER RD/NORTH ST

Service Agreement ID: 9241321005 MAIN STATION

02/18/2014 – 02/28/2014

Rate Schedule: E20P Service to Custs with Max Demands of 1000 kW or More

Customer Charge	11 days @ \$49.28131	\$542.09
Demand Charge 1		
Max Part Peak	2,251.000000 kW @ \$0.24000	204.92
Max Demand	2,251.000000 kW @ \$9.71000	8,290.67
Energy Charges		
Part Peak	225,613.000000 kWh @ \$0.09300	20,982.01
Off Peak	215,859.000000 kWh @ \$0.07734	16,694.54
Power Factor Adjustment (@ 93.00% Power Factor)		-176.59
Revenue Cycle Service Credits		-1.84
Generation Credit		-28,445.36
Power Charge Indifference Adjustment		-520.93
Franchise Fee Surcharge		278.13

03/01/2014 – 03/18/2014

Rate Schedule: E20P Service to Custs with Max Demands of 1000 kW or More

Customer Charge	18 days @ \$49.28131	\$887.06
Demand Charge 1		
Max Part Peak	2,222.000000 kW @ \$0.24000	331.00
Max Demand	2,222.000000 kW @ \$9.71000	13,391.76
Energy Charges		
Part Peak	295,048.000000 kWh @ \$0.09451	27,884.99
Off Peak	409,041.000000 kWh @ \$0.07885	32,252.88
Power Factor Adjustment (@ 93.00% Power Factor)		-281.64
Revenue Cycle Service Credits		-3.01
Generation Credit		-44,352.18
Power Charge Indifference Adjustment		-830.83
Franchise Fee Surcharge		443.58

Details of charges continue on next page. ➡

Electric Usage This Period: 1,145,561.000000 kWh, 29 billing days

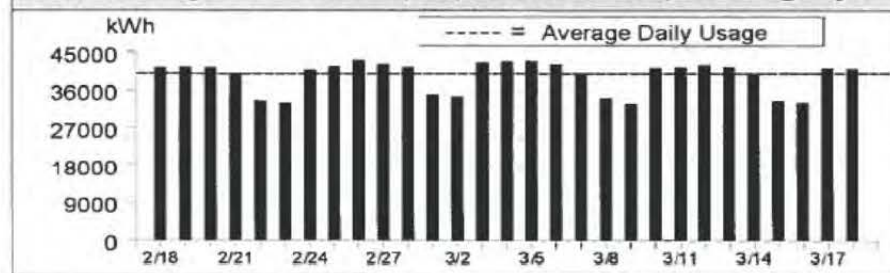

Visit www.pge.com/MyEnergy for a detailed bill comparison.

LIST OF REFERENCES

- [1] Assistant Secretary of Defense for Operational Energy Plans and Programs, “Operational energy strategy: Implementation plan,” Department of Defense, Washington D.C., 2012.
- [2] IEEE, “IEEE Guide for Design, Operation, and Integration of Distributed Resource Island Systems with Electric Power Systems,” IEEE std 1547.4–2011, IEEE, 2011.
- [3] Department of the Navy, “Department of the Navy’s Energy Program for Security and Independence,” Washington, DC, Deputy Assistant Secretary of the Navy (DASN) Energy Office, 2010.
- [4] G. Jagels, “Solving Austerity, How will the DOD provide power to off-the-grid bases?,” *DOD Power, Energy & Propulsion*, pp. 2–6, 2 November 2013.
- [5] United States Marine Corps, “Request for proposal, medium hybrid expeditionary energy system,” MARCORSSCOM, Quantico, VA, January 2012.
- [6] R. L. Kelly, “Optimizing gas generator efficiency in a forward operating base using an energy management system,” M.S. thesis, Naval Postgraduate School, Monterey, CA, 2013. Available: <http://hdl.handle.net/10945/34686>.
- [7] N. J. Peck, “Peak power control with an energy management system,” Naval Postgraduate School, M.S. thesis, Monterey, CA, 2013, Available: <http://hdl.handle.net/10945/32884>
- [8] M. E. Shahidenhpour, M.E. Khodayar, “Cutting campus energy costs with hierarchical control,” *IEEE Electrification Magazine*, pp. 40–56, 23 October 2013.
- [9] Sandia National Laboratories. “SPIDERS.” 6 November 2012. [Online]. Available: http://energy.sandia.gov/?page_id=2781. [Accessed August 2014].
- [10] B. H. Newell, “The evaluation of HOMER as a Marine Corps expeditionary energy pre-deployment tool,” M.S. thesis, Naval Postgraduate School, Monterey CA, 2010, Available: <http://handle.dtic.mil/100.2/ADA531507>.
- [11] G. Boyle, “Solar photovoltaics,” in *Renewable Energy*, New York, NY, Oxford University Press Inc., 2004.
- [12] Satcon, “Satcon 75kW PowerGate Plus.” [Online]. Available: <http://www.satcon.com/en/technologies/powergate-plus>. [Accessed August 2014].

- [13] G. M. Masters, *Renewable and Efficient Electric Power Systems*. Hoboken, NJ, John Wiley & Sons, 2004.
- [14] ABB, “Plant portfolio manager.” [Online]. Available: <https://www.auroravision.net/dash/assets/summary.jsf#439072/488233>. [Accessed August 2014].
- [15] Sandia National Laboratories, “DOE/EPRI 2013 Electricity Storage Handbook in Collaboration with NRECA,” Sandia National Laboratories, Albuquerque, NM, 2013.
- [16] Energy Storage Association. “Technology comparison.” [Online]. Available: http://www.electricitystorage.org/technology/storage_technologies/technology_comparison. [Accessed 2014].
- [17] A. Poullikkas, “A comparative overview of large-scale battery systems for electricity storage,” *Renewable and Sustainable Energy Reviews*, vol. 27, pp. 778–788, 2013.
- [18] T. Bayar, “Batteries for energy storage: New developments promise grid flexibility and stability,” *Renewable Energy World*, 30 August 2011. [Online]. Available: <http://www.renewableenergyworld.com/rea/news/article/2011/08/batteries-for-energy-storage-new-developments-promise-grid-flexibility-and-stability>. [Accessed August 2014].
- [19] Solar City, “Solar City residential,” 2014. [Online]. Available: <http://www.solarcity.com/residential/how-much-do-solar-panels-cost>. [Accessed August 2014].
- [20] The Economist, “The Economist explains,” The Economist Newspaper Limited 2014, 27 January 2014. [Online]. Available: <http://www.economist.com/blogs/economist-explains/2014/01/economist-explains-19>. [Accessed 2014 August].
- [21] K. Korosec, “Details emerge about Tesla’s Nevada gigafactory deal,” *Fortune*, 5 September 2014. [Online]. Available: <http://fortune.com/2014/09/05/details-emerge-about-teslas-nevada-gigafactory-deal/>. [Accessed 18 September 2014].
- [22] M. Pastor, L. Rodriguez, and C. Velez, “Flywheels Store to Save,” *IEEE Electrification Magazine*, pp. 13–20, December 2013.
- [23] U.S. Department of Energy, “Grid energy storage,” U.S. Department of Energy, Washington, DC, 2013.
- [24] K. Bradbury, “Energy storage technology review,” Duke University, Durham, NC, 2010.

- [25] Pacific Gas and Electric Company, “PG&E Electric rates.” [Online]. Available: <http://www.pge.com/notes/rates/tariffs/electric.shtml>. [Accessed 10 August 2014].
- [26] M. Divan, A. Paquette, and Deepak “Providing Improved Power Quality in Microgrids,” *IEEE Industry Applications Magazine*, pp. 34–43, September–October 2014.
- [27] A. Julian, N. Peck, and G. Oriti, “Power electronics enabled energy management systems,” in *Proceedings of IEEE Applied Power Electronics Conference*, Long Beach, CA, 2013.
- [28] Department of Defense Inspector General, “The Department of the Navy Spent Recovery Act Funds on Photovoltaic Projects That Were Not Cost-Effective,” Department of Defense Inspector General, Arlington, VA, September 2011.
- [29] National Renewable Energy Laboratory, “Technology development,” September 2014. [Online]. Available: http://www.nrel.gov/tech_deployment/tools.html. [Accessed September 2014].

THIS PAGE INTENTIONALLY LEFT BLANK

INITIAL DISTRIBUTION LIST

1. Defense Technical Information Center
Ft. Belvoir, Virginia
2. Dudley Knox Library
Naval Postgraduate School
Monterey, California