



**NAVAL
POSTGRADUATE
SCHOOL**

MONTEREY, CALIFORNIA

**SYSTEMS ENGINEERING
CAPSTONE PROJECT REPORT**

**A SYSTEMS APPROACH TO ARCHITECTING A
MISSION PACKAGE FOR LCS SUPPORT OF
AMPHIBIOUS OPERATIONS**

by

Team Amberland
Cohort 311-1310

September 2014

Project Advisors:

Gregory Miller
Paul Shebalin

Approved for public release; distribution is unlimited

THIS PAGE INTENTIONALLY LEFT BLANK

REPORT DOCUMENTATION PAGE			<i>Form Approved OMB No. 0704-0188</i>	
Public reporting burden for this collection of information is estimated to average 1 hour per response, including the time for reviewing instruction, searching existing data sources, gathering and maintaining the data needed, and completing and reviewing the collection of information. Send comments regarding this burden estimate or any other aspect of this collection of information, including suggestions for reducing this burden, to Washington headquarters Services, Directorate for Information Operations and Reports, 1215 Jefferson Davis Highway, Suite 1204, Arlington, VA 22202-4302, and to the Office of Management and Budget, Paperwork Reduction Project (0704-0188) Washington, DC 20503.				
1. AGENCY USE ONLY (Leave blank)		2. REPORT DATE September 2014	3. REPORT TYPE AND DATES COVERED Capstone Project Report	
4. TITLE AND SUBTITLE A SYSTEMS APPROACH TO ARCHITECTING A MISSION PACKAGE FOR LCS SUPPORT OF AMPHIBIOUS OPERATIONS			5. FUNDING NUMBERS	
6. AUTHOR(S) Cohort 311-1310, Team Amberland				
7. PERFORMING ORGANIZATION NAME(S) AND ADDRESS(ES) Naval Postgraduate School Monterey, CA 93943-5000			8. PERFORMING ORGANIZATION REPORT NUMBER	
9. SPONSORING /MONITORING AGENCY NAME(S) AND ADDRESS(ES) N/A			10. SPONSORING/MONITORING AGENCY REPORT NUMBER	
11. SUPPLEMENTARY NOTES The views expressed in this thesis are those of the author and do not reflect the official policy or position of the Department of Defense or the U.S. Government. IRB Protocol number ____N/A____.				
12a. DISTRIBUTION / AVAILABILITY STATEMENT Approved for public release; distribution is unlimited			12b. DISTRIBUTION CODE	
13. ABSTRACT (maximum 200 words) The United States Navy and Marine Corps have identified capability gaps in the areas of collecting Intelligence, Surveillance, Reconnaissance, and Targeting (ISR&T) data and employing fires during amphibious operations. The Littoral Combat Ship (LCS) presents an opportunity to deploy specific mission capabilities in the amphibious theater. This paper identifies the operational, functional, and physical architecture of an LCS Amphibious Warfare Mission Package (LAMP) necessary to provide capabilities associated with ISR&T data collect and fires employment. Physical architecture configurations are evaluated using a discrete-event model. Cost estimates for each alternative are presented in order to identify the LAMP architecture that provides the most cost-effective solution for providing capabilities associated with ISR&T data collection and fires employment. This paper concludes by identifying potential LAMP assets that would provide cost-effective support of amphibious operations. Four feasible alternatives are ultimately identified as cost-effective solutions, with LCCEs ranging from \$105.49M and \$188.22M and providing varying levels of effectiveness in terms of average engagement time and percentage of threats successfully affected.				
14. SUBJECT TERMS littoral combat ship, amphibious warfare, mission package, fire support, intelligence, surveillance, reconnaissance,			15. NUMBER OF PAGES 163	
			16. PRICE CODE	
17. SECURITY CLASSIFICATION OF REPORT Unclassified	18. SECURITY CLASSIFICATION OF THIS PAGE Unclassified	19. SECURITY CLASSIFICATION OF ABSTRACT Unclassified	20. LIMITATION OF ABSTRACT UU	

THIS PAGE INTENTIONALLY LEFT BLANK

Approved for public release; distribution is unlimited

**A SYSTEMS APPROACH TO ARCHITECTING A MISSION PACKAGE FOR
LCS SUPPORT OF AMPHIBIOUS OPERATIONS**

Cohort 311-1310/Team Amberland

Rudolph Banzali
Wade Johnson
Frank Niedzwiecki
Michele Ta-a

Troy Caruso
Hillar Lago
Emily Robison

Andrew Holbrook
Matthew Magalhaes
Adam Scharl

Submitted in partial fulfillment of
the requirements for the degrees of

**MASTER OF SCIENCE IN SYSTEMS ENGINEERING
and
MASTER OF SCIENCE IN ENGINEERING SYSTEMS**

from the

**NAVAL POSTGRADUATE SCHOOL
September 2014**

Lead editor: Adam Scharl

Reviewed by:

Gregory Miller
Project Advisor

Paul Shebalin
Project Advisor

Accepted by:

Cliff Whitcomb
Systems Engineering Department

THIS PAGE INTENTIONALLY LEFT BLANK

ABSTRACT

The United States Navy and Marine Corps have identified capability gaps in the areas of collecting Intelligence, Surveillance, Reconnaissance, and Targeting (ISR&T) data and employing fires during amphibious operations. The littoral combat ship (LCS) presents an opportunity to deploy specific mission capabilities in the amphibious theater. This paper identifies the operational, functional, and physical architecture of an LCS Amphibious Warfare Mission Package (LAMP) necessary to provide capabilities associated with ISR&T data collection and fires employment. Physical architecture configurations are evaluated using a discrete-event model. Cost estimates for each alternative are presented in order to identify the LAMP architecture that provides the most cost-effective solution for providing capabilities associated with ISR&T data collection and surface fires employment. This paper concludes by identifying potential LAMP assets that would provide cost-effective support of amphibious operations. Four feasible alternatives are ultimately identified as cost-effective solutions, with LCCEs ranging from \$105.49M and \$188.22M and providing varying levels of effectiveness in terms of average engagement time and percentage of threats successfully affected.

THIS PAGE INTENTIONALLY LEFT BLANK

TABLE OF CONTENTS

I.	INTRODUCTION.....	1
A.	OVERVIEW	1
B.	AMPHIBIOUS OPERATIONS.....	2
C.	CAPABILITY GAPS.....	6
1.	Fire Support	8
2.	Intelligence, Surveillance, Reconnaissance, and Targeting	11
D.	LITTORAL COMBAT SHIP	12
1.	Surface Warfare Mission Package	15
2.	Anti-Submarine Warfare Mission Package.....	16
3.	Mine Countermeasure Mission Package	17
4.	LCS Concept of Employment	18
E.	PROBLEM STATEMENT	19
F.	SYSTEMS ENGINEERING PROCESS.....	21
II.	SYSTEM CONTEXT	25
A.	NAVY TACTICAL TASKS.....	25
B.	DESIGN REFERENCE MISSION OVERVIEW	26
1.	Concept of Operations.....	28
2.	Projected Operating Environment.....	28
a.	<i>Environmental Conditions</i>	29
b.	<i>Assumed Threat General Conditions</i>	29
c.	<i>Threat Approach Variants</i>	32
3.	Mission Success Requirements	33
4.	Mission Definition	33
5.	Mission Execution	35
6.	Amphibious Raid OPSIT	36
C.	OPERATIONAL REQUIREMENTS.....	37
III.	FUNCTIONAL ANALYSIS AND ALLOCATION	39
A.	METHODOLOGY OVERVIEW	40
B.	ARCHITECTURE TOOL AND LANGUAGE SELECTION	41
C.	OPERATIONAL CONTEXT	42
D.	OPERATIONAL ACTIVITIES	45
E.	SYSTEM FUNCTIONS	49
F.	SYSTEM ELEMENTS.....	52
G.	FUNCTIONAL REQUIREMENTS.....	54
H.	PHYSICAL SOLUTIONS	55
1.	Shipboard Weapon System	56
a.	<i>MK 75 76 mm Gun</i>	56
b.	<i>MK 45 5/62</i>	58
c.	<i>GMLRS</i>	59
d.	<i>Relevant Characteristics</i>	61
2.	Air Detachment	61

	<i>a.</i>	<i>Air Platform</i>	61
	<i>b.</i>	<i>Air Weapon System</i>	65
	<i>c.</i>	<i>Air ISR&T System</i>	67
	<i>d.</i>	<i>Overall LAMP Configuration</i>	71
IV.		MODELING AND EVALUATION	75
	A.	MODEL FACTORS AND EXPERIMENTAL DESIGN	75
	B.	MODEL ARCHITECTURE AND LOGIC	78
		1. ISR&T Model	78
		2. Shooter Model	81
	C.	CONFIGURATION EFFECTIVENESS	84
		1. Percent Detected	85
		2. Engagement Time	87
		3. Percent Affected	89
	D.	COST ESTIMATION	91
		1. Research and Development	93
		2. Procurement	93
		3. Operation and Support	95
		<i>a. Manpower</i>	<i>95</i>
		<i>b. Maintenance</i>	<i>96</i>
		<i>c. Training</i>	<i>97</i>
		<i>d. Spares</i>	<i>97</i>
		<i>e. Ammunition</i>	<i>98</i>
		<i>f. Fuel</i>	<i>99</i>
		4. Overall System Cost Estimation	100
V.		ANALYSIS OF ALTERNATIVES	103
VI.		CONCLUSIONS	111
	A.	WHAT THREATS EXIST FOR AN ARG/MEU DURING AMPHIBIOUS OPERATIONS?	111
	B.	WHAT ALTERNATIVES EXIST FOR PROVIDING JOINT FIRES CAPABILITY WITH A LCS MP?	112
	C.	COULD LCS PROVIDE EFFECTIVE JOINT FIRE SUPPORT?	113
	D.	WHAT WOULD THE MOST COST-EFFECTIVE LCS MISSION PACKAGE BE TO SUPPORT AMPHIBIOUS OPERATIONS?	114
	E.	FUTURE WORK	114
		APPENDIX A – USMC CAPABILITY GAP ANALYSIS	117
		APPENDIX B – LAMP CV-6	121
		APPENDIX C – LAMP SV-5A AND SV-5B	123
		APPENDIX D – MODELS	127
		LIST OF REFERENCES	135
		INITIAL DISTRIBUTION LIST	141

LIST OF FIGURES

Figure 1	ARG/MEU Naval Warships and Support Elements (from USMC n.d.)	5
Figure 2	Disaggregated Amphibious Operations in Challenging Littoral Environment (from USMC 2014a)	6
Figure 3	Mission Package Composition (from Ailes 2014).....	13
Figure 4	LCS Mission Packages (from Ailes 2014).....	14
Figure 5	LCS MPs Diagram (from Lockheed Martin n.d.).....	19
Figure 6	Tailored Systems Engineering Process	22
Figure 7	Phases of an Amphibious Operation (from Riccio 2013).....	27
Figure 8	Situation Map from Exercise Bold Alligator (from Riccio 2013)	30
Figure 9	Terrain Sample for the “Treasure Coast” (Intlink Photo).....	32
Figure 10	LAMP High Level Operational Concept Graphic (OV-1)	36
Figure 11	LAMP External Interfaces	44
Figure 12	LAMP Operational Activity Hierarchy	45
Figure 13	First Level Operational Activities IDEF0 Diagram.....	48
Figure 14	Functional Hierarchy	50
Figure 15	Top-Level Functional Flow	51
Figure 16	System Element Hierarchy	53
Figure 17	Potential Shipboard Weapons Systems.....	56
Figure 18	OTO Melara MK 75 76 mm gun (U.S. Navy Photo).....	57
Figure 19	MK 45 5/62 Lightweight Gun System (U.S. Navy Photo).....	58
Figure 20	GMLRS Rocket (U.S. Army photo)	60
Figure 21	Integrated GLRMS (from Miller, Georgiadis; Laun 2013)	60
Figure 22	AH-1Z Viper Attack Helicopter (U.S. Navy Photo).....	62
Figure 23	MH-60R Seahawk Helicopter (U.S. Navy Photo)	63
Figure 24	MQ-8B Fire Scout (U.S. Navy Photo).....	64
Figure 25	Potential Air-to-Ground Systems.....	67
Figure 26	AN/AAS-44C(V) (U.S. Navy Photo)	68
Figure 27	SAR Image (from Sandia National Laboratory).....	69
Figure 28	AN/AAQ-30 (U.S. Navy Photo).....	70
Figure 29	AN/ZPY-4(V)1 Radar (from Telephonics n.d.b).....	70
Figure 30	AN/AAQ-22E (U.S. Navy Photo)	71
Figure 31	BOE Estimation of Percentage of Threats Detected over Time for Representative LAMP Configuration	79
Figure 32	ISR&T Discrete-Event Model Block Diagram.....	80
Figure 33	BOE Estimation of Percentage of Successful Fire Missions Associated with a Representative LAMP Configuration	82
Figure 34	Shooter Discrete-Event Model Block Diagram	83
Figure 35	Percent Detected vs. Air Detachment Configuration.....	86
Figure 36	Engagement Time vs. Air Detachment Configuration for each Shipboard Weapon	87
Figure 37	Percent Affected vs. Air Detachment Configuration for each Shipboard Weapon	89

Figure 38	LAMP Cost Breakdown Structure	92
Figure 39	MOE 2 Utility Curve	105
Figure 40	LAMP Configurations' OMOE Comparison.....	106
Figure 41	LAMP LCCE vs. OMOE.....	107
Figure 42	LAMP ISR Discrete-Event Model Snapshot	128
Figure 43	LAMP Shooter Discrete-Event Model Snapshot (part 1 of 5).....	129
Figure 44	LAMP Shooter Discrete-Event Model Snapshot (part 2 of 5).....	130
Figure 45	LAMP Shooter Discrete-Event Model Snapshot (part 3 of 5).....	131
Figure 46	LAMP Shooter Discrete-Event Model Snapshot (part 4 of 5).....	132
Figure 47	LAMP Shooter Discrete-Event Model Snapshot (part 5 of 5).....	133

LIST OF TABLES

Table 1	POM-16 MCGL Excerpt (from USMC 2014a).....	8
Table 2	LCS SUW MP Mission Systems (after Schoenster 2008).....	15
Table 3	LCS ASW MP Mission Systems (after Schoenster 2008).....	17
Table 4	LCS MCM MP – Mission Systems (after Schoenster 2008).....	18
Table 5	Elements of the enemy mechanized infantry brigade.....	31
Table 6	Joint Capability Areas Applicable to the LAMP (after U.S. DOD 2011)	34
Table 7	Definition of Commonly Used Architecture Terms (after U.S. Navy 2011a)	42
Table 8	LAMP Functional Requirements	54
Table 9	Relevant Shipboard Weapon System Characteristics (after Polmar 2005; Graham 2004; Pincoski 2008)	61
Table 10	Relevant Air Platform Characteristics (after U.S. Navy 2014a, Sikorsky 2014, and U.S. Navy 2014c).....	65
Table 11	Relevant Missile Characteristics (after Jacobson 2010)	66
Table 12	Relevant Air ISR&T Asset Characteristics (after Raytheon 2014b)	71
Table 13	LAMP Alternative Factor Levels.....	76
Table 14	Evaluated LAMP Air Detachment Configurations.....	76
Table 15	Evaluated LAMP Configurations	77
Table 16	ISR&T Discrete-Event Model Functional Description.....	81
Table 17	ExtendSim Shooter Model Functional Description	84
Table 18	Top Five Most Effective Feasible LAMP Configurations in Terms of Average Engagement Time.....	88
Table 19	Most Effective Feasible LAMP Configurations in Terms of Average Percentage of Targets Successfully Affected	90
Table 20	System Procurement Costs (after Oestergaard 2014a, U.S. Army 2013, U.S. Navy 2014f, U.S. Navy 2014g, U.S. Navy 2014h, and U.S. Navy 2011b)	95
Table 21	Operations Manpower Estimates (after U.S. DOD 2013)	96
Table 22	Maintenance Costs (after U.S. Army 2014b; U.S. Navy 2014d).....	97
Table 23	Spares Costs (after U.S. Army 2014b and U.S. Navy 2014d).....	98
Table 24	Ammunition Costs (after U.S. Army 2013; U.S. Navy 2014g; U.S. Navy 2014h)	99
Table 25	Fuel Costs (after U.S. Navy 2014d).....	100
Table 26	Asset LCCE Comparison.....	100
Table 27	LAMP Configuration LCCEs	101
Table 28	Top Five Most Effective Feasible LAMP Configurations in terms of OMOE.....	106
Table 29	Non-Dominated LAMP Alternatives.....	108
Table 30	Considered Capability Gaps (after USMC 2014a; U.S. DOD 2005; U.S. DOD 2010).....	117
Table 31	LAMP capability to operational activities mapping (CV-6).....	121

Table 32	LAMP operational activity to systems function traceability matrix (SV-5a) (1 of 1).....	124
Table 33	LAMP operational activity to systems function traceability matrix (SV-5a) (2 of 2).....	125
Table 34	LAMP operational activity to systems traceability matrix (SV-5b)	126

LIST OF ACRONYMS AND ABBREVIATIONS

A2AD	anti-access area denial
AF	amphibious force
AMW	amphibious warfare
AOR	area of responsibility
APKWS	Advanced Precision Kill Weapon System
ARG	amphibious readiness group
ASW	anti-submarine warfare
ATF	amphibious task force
BOE	back of the envelope
C2	command and control
C4I	command, control, communications, computers, and intelligence
CBA	capabilities-based analysis
CBS	cost breakdown structure
CONOPS	concept of operations
CSG	carrier strike group
DOD	Department of Defense
DoDAF	Department of Defense architecture framework
DRM	design reference mission
EFFBD	enhanced functional flow block diagram
EF-21	Expeditionary Force 21
EO/IR	electro-optical/infrared
ESG	expeditionary strike group
F2T2EA	find, fix, track, target, engage, and assess
FAA	functional area analysis
FLIR	forward-looking infrared
FO	forward observer
FY	fiscal year
GMLRS	Guided Multiple Launch Rocket System
GWOT	global war on terror
HIMARS	High Mobility Artillery Rocket System
HSD	honest significant difference
ICD	initial capabilities document
ISAR	inverse synthetic aperture radar
ISR&T	intelligence, surveillance, reconnaissance, and targeting
JCA	joint capability area
JCIDS	joint capabilities integration development system
JIC	joint intelligence center
JP	joint publication
LAMP	littoral combat ship amphibious warfare mission package

LCAC	air cushion landing craft
LCCE	life-cycle cost estimate
LCCE	life-cycle cost
LCS	littoral combat ship
LCSRON	littoral combat ship squadron
LCU	utility landing craft
LF	landing force
LHA	general purpose amphibious assault ship
LHD	multipurpose amphibious assault ship
LLC	launcher loader module
LOGIR	Low-Cost Guided Imaging Rocket
LPD	amphibious transport dock ship
LSD	amphibious dock landing ship
MAGTF	Marine air and ground task force
MCCL	Marine Corps capability list
MCGL	Marine Corps gap list
MCM	mine countermeasures
MCO	major contingency operation
MEB	Marine expeditionary brigade
MEU	Marine expeditionary unit
MLRS	Multiple Launch Rocket System
MOE	measure of effectiveness
MP	mission package
MSC	military sealift command
NM	nautical mile
NSFS	naval surface fire support
NTA	navy tactical activity+B29
O&S	operation and support
OMOE	overall measure of effectiveness
OPSIT	operational situation
OSMIS	Operating and Support Management Information System
POE	projected operating environment
POM	program objective memorandum
POR	program of record
R&D	research and development
SACC	supporting arms coordination center
SAG	surface action group
SAR	synthetic aperture radar
SE	systems engineering
SUW	surface warfare
TACON	tactical control
TSS	Target Sight System

UNTL	Universal Naval Task List
US	United States
USMC	United States Marine Corps
USV	unmanned surface vehicle
VAMOSC	Visibility and Management of Operating and Support Costs
VTUAV	vertical-takeoff unmanned aerial vehicle

THIS PAGE INTENTIONALLY LEFT BLANK

EXECUTIVE SUMMARY

This paper identifies alternatives for providing fire support during amphibious operations with a littoral combat ship (LCS) mission package and evaluates the cost-effectiveness of those alternatives; alternative solutions are defined by the shipboard weapon system and air detachment assets that make up a given configuration. Four feasible alternatives are ultimately identified as cost-effective solutions, with life-cycle cost estimates (LCCEs) ranging from \$105.49M and \$188.22M and providing varying levels of effectiveness in terms of average engagement time and percentage of threats successfully affected. The four feasible alternatives consist of varying combinations of no shipboard weapon system or a 76 millimeter gun and an air detachment consisting of one or two MQ-8B aircraft equipped with the advanced precision kill weapon system (APKWS) or a single MH-60R aircraft equipped with the APKWS or Hellfire missiles.

This paper considers the characteristics, feasibility, and cost-effectiveness of a LCS amphibious warfare MP (LAMP) in terms of capability gaps current experienced during amphibious operations. Specifically, this paper considers the ability of a LAMP to provide ISR&T data collection, aviation fires, and naval surface fires in support of amphibious operations. These activities were chosen for consideration due to their relationship to one another (e.g., fires employment requires the sufficient collection of targeting data prior to engagement). As a result of this choice, a supporting objective of this project was to validate the consideration of ISR&T and naval surface fires for inclusion in a single MP.

This paper presents the operational, functional, and physical architecture of a LAMP to provide capabilities associated with ISR&T data collection and fires employment. A design reference mission (DRM) is presented in order to describe the environment in which a LAMP would be expected to operate. The DRM serves as a basis for identifying the measures of effectiveness (MOEs) against which potential solutions are evaluated in order to identify the most effective LAMP design. The MOEs identified are:

1. Percent of targets identified in 4 hours
2. Time between system receipt of fire mission and target impact
3. Percent of targets successfully affected

The developed operational architecture addresses the external activities that the LAMP must interact with as well as internal activities necessary for the LAMP to perform ISR&T data collection and fires employment. The operational architecture serves as the basis for a supporting functional architecture. The functional architecture defines the specific functions that the system must perform in order to accomplish the internal activities defined in the operational architecture, as well as the relationship of those functions to one another.

With the operational and functional architectures established, the project identifies a physical architecture that would support the defined functional architecture. Elements are defined by considering related functionality and allocating that related functionality to a single element. Ultimately, the physical architecture of the LAMP consists of shooter, ISR&T, command and control, and support services subsystems. The shooter subsystem is further decomposed to shipboard and air weapon systems, while the ISR subsystem is further decomposed to air platforms and sensor subsystems. Currently fielded assets that provide the functionality associated with a given subsystem are identified in order to define the potential configurations of a LAMP.

Potential configurations of a LAMP include a shipboard weapon system and an air detachment. This project considers the use of a 76 millimeter gun or a Global Positioning System Multiple Launch Rocket System (GMLRS) as the shipboard weapon system of a LAMP. This project considers air detachments consisting of up to three MQ-8B Fire Scout unmanned aerial vehicles equipped with an Advanced Precision Kill Weapon System (APKWS), one MH-60R Seahawk helicopter equipped with Hellfire missiles or a APKWS, or one AH-1Z Viper helicopter equipped with Hellfire missiles or a APKWS.

Physical configurations are evaluated using the output from simulation of a discrete-event model to determine the effectiveness of each LAMP configuration in terms

of collecting ISR&T data and employing fire support; effectiveness is described in terms of the identified MOEs. The MOEs are used to calculate an overall measure of effectiveness (OMOE) for each LAMP configuration, using statistical analysis to identify the significant differences in effectiveness of 36 evaluated LAMP configurations.

This paper also presents the estimated cost of each potential solution. The cost of the 36 evaluated LAMP configurations is estimated by considering the research and development, procurement, and operations and maintenance costs of the assets associated with a given configuration. These asset costs support life-cycle cost estimates of each LAMP configuration in support of identifying cost-effective LAMP configurations in terms of ISR&T data collection and fires employment.

With OMOE and cost estimation data of potential physical configurations identified, the paper presents an analysis of alternatives (AoA) that identifies the most cost-effective LAMP configuration, of those evaluated, for providing ISR&T data collection and fires employment in support of amphibious operations. The AoA considers cost as an independent variable, identifies the non-dominated solutions, and discusses the relative benefits and drawbacks of each of the identified non-dominated solutions.

THIS PAGE INTENTIONALLY LEFT BLANK

I. INTRODUCTION

A. OVERVIEW

Through forward presence, the United States naval forces, including amphibious forces, safeguard the country's national interests in peace while also providing deterrence against hostile acts of aggression. With 80 percent of the world's population living within 200 miles of the major ocean coastlines, the sea provides U.S. naval forces both a strategic and operational avenue for the projection of U.S. international power to influence the global system, protect U.S. citizens, assure U.S. Allies, and respond in times of crises (U.S. Marine Corps [USMC] 2012).

Three forward deployed Marine Expeditionary Units (MEUs) of the Marine Corps, embarked aboard three naval Amphibious Ready Groups (ARGs), compose the "Tip-of-the-Spear" of amphibious forces. While very capable in the low end of the spectrum of conflict, the capabilities of forward deployed naval amphibious force need to be re-evaluated and enhanced in order to ensure the dominance of the Navy force in the littorals across the entire spectrum of conflict (The Ellis Group 2012). Currently, amphibious forces have several capability gaps while operating in the littorals. With the recent initial deployments of individual littoral combat ship (LCS) platforms, this project explores how LCS can enhance the capabilities of naval amphibious forces in the littorals.

The U.S. Department of Defense (DOD) defines the littorals as "an area extending from a transition point from open ocean (for example, the seabase or a launch point) to more constrictive and shallower waters, to the shore, and onward to those inland areas that can be attacked, supported and defended from the sea as defined by the Assured Maritime Access in the Littorals Initial Capabilities Document (ICD)" (DOD 2005, 1). "Given the range of modern systems, power projection in the littoral battle covers hundreds of miles in both directions and extends into the air and cyberspace. The maritime domain—which has always had a landward component—now extends much further, and encompasses a much more complex set of challenges" (USMC 2012, 33).

This project considers the ability of the LCS to effectively support amphibious operations. More specifically, this project identifies the requirements for a LCS mission package (MP) designed to perform joint fires and supporting intelligence, surveillance, reconnaissance, and targeting (ISR&T) missions. This chapter introduces the concepts of amphibious operations, the assets utilized in support of amphibious operations, joint fires as employed in the littorals, the LCS seaframe and mission package concept, and the systems engineering process used during this project.

B. AMPHIBIOUS OPERATIONS

As defined in Joint Publication (JP) 3-02, “An amphibious operation is a military operation launched from the sea by an amphibious force (AF) embarked in ships or craft with the primary purpose of introducing a landing force (LF) ashore to accomplish the assigned mission” (U.S. DOD 2009, ix). An AF is comprised of an LF and an amphibious task force (ATF), which is the naval element formed to conduct amphibious operations (U.S. DOD 2009). Amphibious operations apply maneuver principles to maritime power projection in joint and multinational operations (U.S. DOD 2009). Maritime-response capabilities provide a range of rapid intervention options that can be tailored to the demands of each contingency (The Ellis Group 2012). Operating from the seabase, AFs act as a natural deterrent to potential adversaries while providing the joint force commander with a mobile force. This force is flexible enough to facilitate the entry of follow-on forces, be the main or supporting effort, or achieve the objective in one swift operation.

Amphibious operations can be scaled and tailored to support a specific mission and can be introduced across the range of military operations. Amphibious operations are categorized into five types: assaults, raids, demonstrations, withdrawals, and amphibious support to other operations (U.S. DOD 2009). Planning for any amphibious operation normally begins with a higher commander issuing an order to the commander of the AF to initiate the twenty-one steps of the deliberate amphibious planning process. Alternatively, the order is issued to the amphibious squadron commander of a forward

deployed AF to initiate the rapid response planning process, which is a unique capability of the standing ARG/MEUs.

An amphibious assault is the traditional type of amphibious operation and seeks to establish an LF upon a hostile or potentially hostile shore (U.S. DOD 2009). An amphibious assault requires sufficient elements of the main body of the AF to be present in the operational area. In the amphibious assault, combat power is progressively phased ashore in order to accomplish the assigned mission (U.S. DOD 2009); the employment of combat power is preceded by advance operations and pre-assault operations.

An amphibious raid is an operation smaller in scale than an assault. The raid involves a swift incursion into—or the temporary occupation of—an objective followed by a planned withdrawal. An amphibious raid requires extensive planning from the surprise arrival to the withdrawal (U.S. DOD 2009).

An amphibious demonstration is intended to occupy the intelligence resources of an enemy by introducing false details on time, place, or strength of the main operation. The demonstration must occur over a long enough period to allow the enemy to react to the false information (U.S. DOD 2009).

Amphibious withdrawals are operations conducted to extract friendly forces or civilians by sea in ships or craft from a hostile or potentially hostile shore. Withdrawal begins with establishment of defensive measures in the embarkation area and ends when all elements of the force have been extracted and embarked on designated shipping. Generally, operations focus on deterring war, resolving conflict, promoting peace, and supporting civil authorities in response to domestic crises (U.S. DOD 2009).

Supporting operations are conducted by forces other than the AF and are enablers that support the execution of the amphibious operations. Support for amphibious operations can be broken down into intelligence, fire support, communications, logistics, protection, and seabasing (U.S. DOD 2009).

For this paper, the primary AF of concern is the collective ARG/MEU. Typically, an amphibious operation is joint in nature and may require extensive air, land, maritime, space, and special operation forces participation. However, the deployment of such forces

requires time prior to the conduct of amphibious operations. The forward deployed ARG/MEU provides a rapid-response capability for the joint force commander or the joint force maritime component commander to coordinate a small-scale amphibious operation (senior Marine advisor to naval sea systems command, pers. comm.).

The ARG/MEU is the most frequently employed ATF formed to conduct amphibious operations. The MEU, serving as the LF, is embarked aboard the ships of the ARG, together comprising a self-contained, forward deployed AF.

The ATF of the ARG consists of, at a minimum, three Navy ships specifically designed to transport, land and support the LF (U.S. DOD 2009):

1. One amphibious assault ship (either the general purpose amphibious assault ship (LHA) or the multipurpose amphibious assault ship (LHD))
2. One amphibious transport dock ship (LPD)
3. One amphibious dock landing ship (LSD)

In addition to the ships, the principal naval elements of the ARG are a Naval Beach Group Element that includes Beachmasters, who control the movement of personnel and equipment across the beach; Assault Craft Unit elements that bring the landing craft; both air cushion landing craft (LCAC) and utility landing craft (LCU) platforms that move equipment and personnel from the ship to the shore; the tactical air control squadron element that provides aviation control; a Fleet Surgical Team that provides enhanced medical support; and a Helicopter Sea Combat Squadron element that provides airborne search and rescue, vertical replenishment, air and sea defense and limited assault support (USMC n.d.).

Normally comprised of over 2,400 personnel, a MEU is the smallest standalone Marine air-ground task force (MAGTF) that is constructed around a reinforced infantry battalion, a composite squadron, and a task-organized combat service support element (U.S. DOD 2014a). The MEU provides a quick reaction capability for crisis response and is capable of limited combat operations (U.S. DOD 2014a). Figure 1 depicts the ships of the ATF and the representative air and ground equipment for the MEU that is carried by the ships.

Within this context, an ARG/MEU may be responsible for a single objective that supports the overall operation. Depending on the specific objective and the difficulty of other objectives, the ARG/MEU may receive fire support, intelligence, target designation, or other assistance from other assets, such as land-based aircraft, a carrier strike group (CSG), or ground units in the area of interest, and must be able to effectively communicate and coordinate with those assets.



Figure 2 Disaggregated Amphibious Operations in Challenging Littoral Environment (from USMC 2014a)

C. CAPABILITY GAPS

This paper considered the capability gaps associated with amphibious operations. For this consideration, the team evaluated several existing documents identifying capability gaps for amphibious operations, including the USMC Program Objective

Memorandum (POM) 16 Marine Corps gaps list (MCGL), Joint Fires ICD, Unmanned Systems ICD, and Ship to Shore Connector ICD.

The MCGL was developed in support of the POM-16 Marine Corps Enterprise Integration Plan. As stated in the 2013 USMC Marine Corps Capability List (MCCL), the MAGTF Integration Division provides capability datasets to support the capabilities based assessment (CBA) process supporting the Joint Capabilities Integration Development System (JCIDS) used to define the MCGL. The CBA reviews current operational readiness based on joint doctrine and ICDs and identifies those USMC capabilities requiring the greatest financial resources. The Marine Corps CBA branch produces and maintains the MCGL for annual review and update.

As part of the POM-16 MCGL process, each capability gap was assigned a risk category based on the gap's potential operational impact. The potential impact of the realized capability gap and the MCGL rank associated with the given capability gap are taken into account to calculate a normalized gap score which is also captured in the MCGL table. The normalized gap score is used to rank all of the gaps listed in the MCGL. An excerpt of the MCGL is shown in Table 1.

The POM-16 MCGL annual review process validates existing capability gaps, identifies new capability caps, and consolidates areas of redundancy. Each gap has an associated title and description to detail the specific capability gap, as well as an associated MCCL capability area. The top-ranking MCCL capability area in the POM-16 MCGL is 3.2 Engage Targets. Table 1 provides an excerpt of the MCGL to provide an example of the information considered during this analysis.

Table 1 POM-16 MCGL Excerpt (from USMC 2014a)

Gap Rank	POM-16 Gap ID	POM-16 Gap Title	Gap Description	Gap Score Normalized	Gap Status	MCCL Capability Area	MCCL Rank
1	15-3.1-G3	Provide surface assault lift during amphibious maneuver	(U) The Assault Amphibian	1.0000	Remains "As Is" from POM-	3.1 Maneuver Forces	8
2	15-3.2-G8	EW Services Architecture	(U//FOUO)	0.981	Remains "As Is" from POM-	3.2 Engage Targets	1
3	15-7.1.2-G1	EW Force Protection	(U//FOUO)	0.970	Remains "As Is" from POM-	7.1 Prevent Attack	19
161	16-2.2-G8	Obtain Authorization to Collect	(U) The Marine Corps has limited	0.009	Modified from POM-15 MCGL	2.2 Collect Data and	31
162	15-9.2.3-G1	Portfolio Management	(U) Limited ability for C4 to monitor	0.006	Remains "As Is" from POM-	9.2 Strategy and	24
163	15-9.5-G1	Capital planning, investment control (CPIC)	(U) Limited C4 ability to perform	0.003	Remains "As Is" from POM-	9.5 Program, Budget and	29

After reviewing the POM-16 MCGL and listed ICDs, the identified capability gaps (i.e., ship-to-shore connectors; ISR&T in support of employing fires; employment of fires; command and control of fires; and logistics support) were evaluated, and the joint fires and supporting ISR&T capabilities were chosen for further assessment by this project. The gaps not considered by this project provide an area for future work.

The remainder of this section provides an overview of the capability gaps associated with fire support and ISR&T data collection operations as they relate to amphibious operations. A complete list of the fire support and ISR&T capability gaps considered by this project is provided as Appendix A.

1. Fire Support

Fire support is defined as “fires that directly support land, maritime, amphibious, and special operations forces to engage enemy forces, combat formations, and facilities in pursuit of tactical and operational objectives” (U.S. DOD 2014a, 94). “Fires” is defined as “the use of weapon systems to create specific lethal and nonlethal effects on a target” (U.S. DOD 2014a, 94).

Joint fires capabilities [are to] be fully synchronized with maneuver in simultaneous and distributed engagements while also protecting on-going insertion, support and sustainment forces, during ideal and restricted weather, terrain and other environmental conditions. Integrating guidance from the major contingency operation (MCO) Joint Operation Commander, the Army Joint Fires concept of operations (CONOPS), the Marine Corps Ship to Objective Maneuver and Distributed Operations

CONOPS, and Air Force Global Persistent Attack CONOPS, the Joint Fires in Support of Expeditionary Operations in the Littorals ICD is holistically applicable as a joint interdependent capability to deliver complementary and reinforcing effects. The Commander requires effective, agile and responsive fires capabilities, therefore the underlying concept of operations is that joint fires are necessary wherever future combat operations are conducted, from traditional warfare to irregular warfare scenarios. (U.S. DOD 2005, 6)

As described in the Joint Fires ICD, the joint fires kill chain includes nine critical tasks:

- Detect and locate targets
- Dynamically re-task ISR&T assets
- Select and analyze fused, all-source, multi-intelligence information
- Exercise command and control
- Establish precise geo-location of a target at a specific point in time
- Track and identify targets and establish track priorities
- Assign target-weapon pairing and provide target locations, target descriptions, and specify methods of fire
- Conduct Joint Fire Support to achieve desired effects
- Conduct an effects-based assessment of executed fires

“Existing fielded and program of record (POR) systems have shortcomings that limit the ability of the Commander to employ joint fires against the target sets expected during the MCO and global war on terrorism (GWOT) campaign scenario” (U.S. DOD 2005, 7). The capabilities not adequately provided by existing fielded and POR systems are discussed below and referenced from the Joint Fires and Unmanned Systems ICDs.

The Joint Fires ICD identified the following capability gaps associated with fire support:

- The ability to engage known and/or identified targets when friendly forces are in close contact or when collateral damage is a concern.
- The ability to provide fires to achieve volume effects.

Prior to the promulgation of JCIDS, the naval surface fire support (NSFS) mission need statement documented the capability requirement for NSFS. This document, last

revised in 1992, provided requirements for ship-mounted weapons systems that would support the LF during an amphibious operation with defended territory. Improvements in joint warfighting capabilities and shared command and control structures created an impetus for redefining the employment of supporting fires (U.S. DOD 2005).

The ICD for Joint Fires, published in 2005, goes a long way toward building the foundation for the modern-day concept of “a single naval battle,” which aims to integrate carrier-strike aviation, submarines, expeditionary fixed-wing capabilities, missile defense, rotary-wing fires, and surface fire support and ground fires capability. The capability to conduct Joint Fires is a critical enabler for the joint force commander (USMC 2012).

During the development of the ICD for Joint Fires, “the ICD functional area analysis (FAA) was conducted using a flow-down approach linking strategic guidance, joint concept guidance, individual Service guidance and all Service task lists” (U.S. DOD 2005, 2). The FAA categorized the tasks, standards and conditions using the find, fix, track, target, engage and assess (F2T2EA) kill chain and identified the following capability gaps:

- Gap 1 – The ability to transmit and receive the required targeting information from ISR&T sources to fires command and control systems
- Gap 2 – The ability to engage moving point and moving area targets under restricted weather conditions
- Gap 3 – The ability to engage known and/or identified targets when friendly forces are in close contact or when collateral damage is a concern
- Gap 4 – The ability to provide fires to achieve volume effects (i.e., suppression) (U.S. DOD 2005)

The ICD for Joint Fires states that “the results of the target and engage capability gap analysis confirmed that existing fielded and program-of-record systems have shortcomings that limit the ability of the Commander to employ joint fires against the target sets expected during the MCO and GWOT campaign scenario” (U.S. DOD 2005, 7).

2. Intelligence, Surveillance, Reconnaissance, and Targeting

The definitions of ISR&T are provided below.

Intelligence: “1. The product resulting from the collection, processing, integration, evaluation, analysis, and interpretation of available information concerning foreign nations, hostile or potentially hostile forces or elements, or areas of actual or potential operations. 2. The activities that result in the product. 3. The organizations engaged in such activities” (U.S. DOD 2014a, 128).

Surveillance: “The systematic observation of aerospace, surface, or subsurface areas, places, persons, or things, by visual, aural, electronic, photographic, or other means” (U.S. DOD 2014a, 254).

Reconnaissance: “A mission undertaken to obtain, by visual observation or other detection methods, information about the activities and resources of an enemy or adversary, or to secure data concerning the meteorological, hydrographic, or geographic characteristics of a particular area” (U.S. DOD 2014a, 221).

Targeting is “the process of selecting and prioritizing targets and matching appropriate response to them, considering operational requirements and capabilities” (U.S. DOD 2014a, 260).

The Joint Fires ICD identified the following capability gaps associated with collecting ISR&T data:

- The ability to transmit and receive the required targeting information from ISR&T sources to fires command and control systems.
- The ability to engage moving point and moving area targets under restricted weather conditions.

Unmanned aerial vehicles and unmanned surface vehicles (USVs) perform useful surveillance and presence roles (Chew 2008). They have the distinct advantage of being able to operate without incurring risks to human life (Chew 2008). They can also operate under harsh environmental conditions (Chew 2008). This will significantly increase the situational awareness of ships in a coalition and also the United States’ value as a useful partner. USVs should continue to feature in our future deployments (Chew 2008).

The ICD for Unmanned Systems documents a material solution (i.e., unmanned systems) for additional gaps associated with ISR&T capabilities. The capability gaps identified in the ICD, written in 2010, remain applicable to the current fleet and have been determined to apply to amphibious operations. The specific missions, tasks, and functions related to the joint fires F2T2EA kill chain identified in the ICD that cannot currently be performed or are unacceptably limited and are experienced during amphibious operations include:

- “The ability to conduct persistent multi-discipline intelligence collection, near-real-time reallocation, and dynamic re-tasking of assets. [...] This gap is an issue of both sufficiency (insufficient number of intelligence collection assets) and a lack of capability (limited sensing and endurance of assets)” (U.S. DOD 2010, 7).
- “The sufficient capability to deliver lethal and non-lethal fires, field-scalable munitions, and advanced technologies (electromagnetic, high power microwave, and high pulse lasers), where manned systems are limited, restricted, denied entry, or unavailable” (U.S. DOD 2010, 7).

D. LITTORAL COMBAT SHIP

As compared to other U.S. surface combatants, the LCS is a relatively inexpensive naval combatant optimized for near-shore missions, with a design specifically made for the littoral environment. It is a fast, maneuverable, shallow-draft ship that has a reconfigurable single-mission focus and is currently planned to specialize in neutralizing mines, small surface crafts, and diesel submarines. The LCS was designed with a modular, open-system architecture, allowing flexibility in a dynamic battlespace. It can store unmanned air, surface, and underwater vehicles, and boasts onboard sensors, weapons, and command and control systems. With the addition of the LCS, the naval and joint forces gain operational flexibility for sea superiority and assured access to key naval points, as well as a crucial member of the future surface combatant family of ships. There are two variants of the LCS: the Lockheed Martin variant (Freedom Class) is based on a steel semi-planing monohull, while the General Dynamics variant (Independence Class) is based on an aluminum trimaran hull (O’Rourke 2011).

The LCS is the first Navy shipbuilding program that develops and utilizes the seaframe concept, which possesses certain inherent capabilities. The LCS can be outfitted

with interchangeable “plug-and-fight” systems packages called mission modules, which support a multitude of specific tasks. With an open architecture, the LCS contains physical and digital interfaces that support mission module systems, command, control, communications, computers, and intelligence (C4I) systems, and common control systems for unmanned vehicles. The physical and digital interfaces can also seamlessly integrate with the ship’s auxiliary support and C4I systems (U.S. Navy 2004).

The LCS specializes in carrying MPs that can be installed on the ship. MPs were created as a response to an evolving threat environment and the emergence of warfighting gaps in coastal environments (U.S. Navy 2004). A MP consists of mission modules, support aircraft, and the crew associated with the mission modules and aircraft. Mission modules consist of mission systems (e.g., vehicles, sensors, and weapons) and associated support equipment that install on the seaframe via standard interfaces (U.S. Navy n.d.). Support aircraft may consist of manned or unmanned rotary-wing aircraft, as supported by the LCS hangar and flight deck. The crew includes the personnel required to operate and maintain the MP to achieve the given mission. Figure 3 depicts the association of mission modules, support aircraft, and crew that make up a MP.

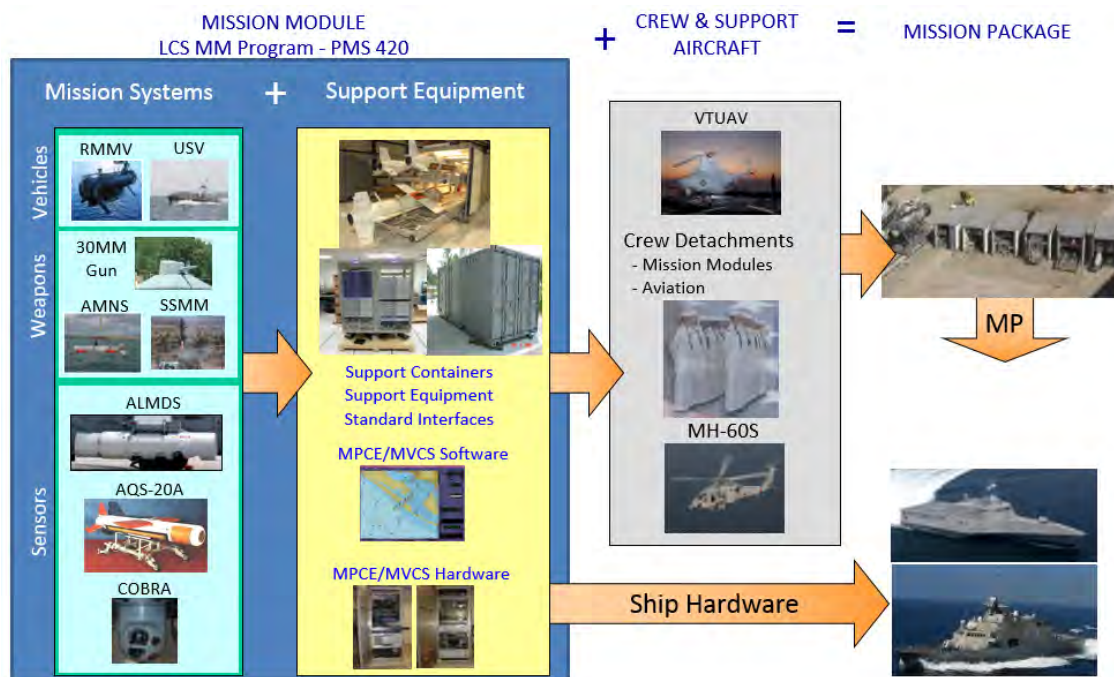

Figure 3 Mission Package Composition (from Ailes 2014)

The three MPs currently planned for the LCS are specialized for mine countermeasure (MCM), surface warfare (SUW) and anti-submarine warfare (ASW) missions. LCS seaframes with MCM MPs will replace the current inventory of mine countermeasure ships. The SUW MP will complement and expand existing fleet capabilities to neutralize small boat threats in the littorals. The ASW MP will augment existing fleet capacity to counter the expanding threat posed by quiet diesel submarines. Importantly, the versatility and lift capacity of the LCS seaframe could support a wide range of secondary missions, including transport of Marine and special operations forces, afloat staging base support, and sea-based fire support (U.S. Navy, USMC, USCG 2010). Figure 4 depicts the three currently planned LCS mission packages.

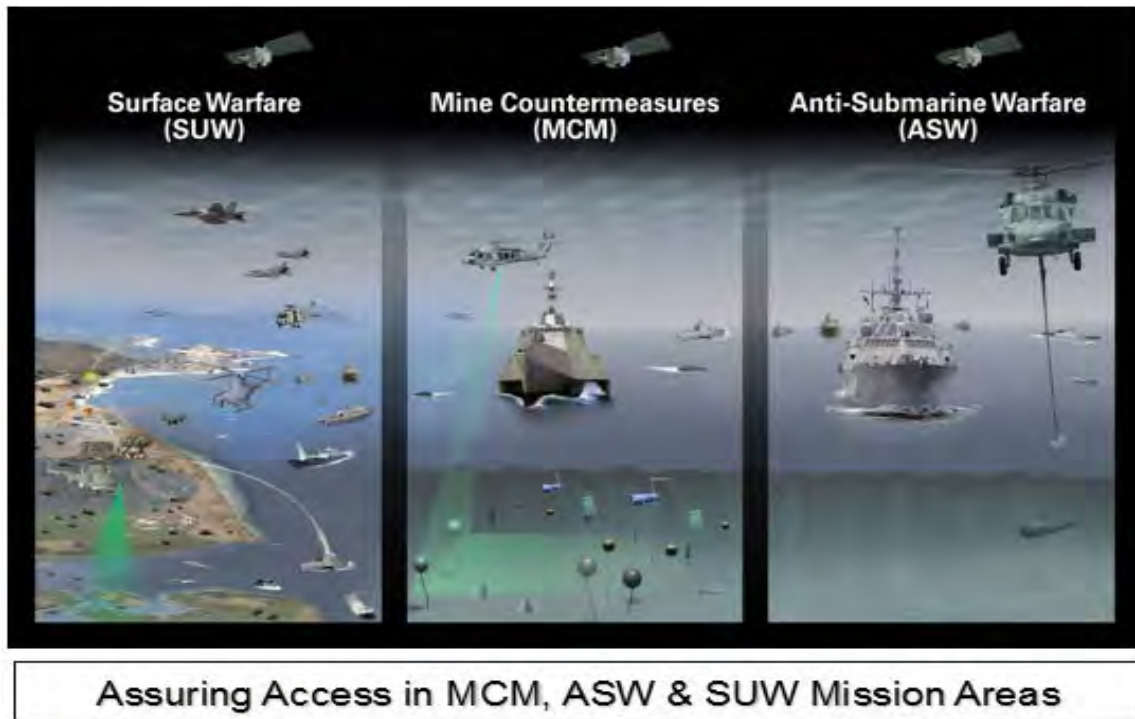

Figure 4 LCS Mission Packages (from Ailes 2014)

The open architecture seaframe concept allows the LCS to respond to the ever-evolving threat environment. All MPs are intended to be interchangeable between both LCS class ships and can be swapped for a different MP in a short time period. This

unique capability provides commanders flexibility in the ever-changing warfighting environment.

1. Surface Warfare Mission Package

The LCS will use its speed, organic weapons capability, embarked aviation, and unmanned surface vehicle capability to provide a layered defense against surface threats in coastal areas. To optimize this capability, a LCS engaged in surface warfare will utilize a SUW MP to augment its own sensors and weapons to improve detection and engagement capability. The LCS operating in support of a CSG or expeditionary strike group (ESG), or as part of a surface action group (SAG), will have the C4I ability to transmit and receive operational and tactical data. LCS SUW operations will also enable the Joint Force Commander to assess the situation in the battlespace and optimally position and defend a seabase, maximizing overall force support and power projection. Table 2 lists the mission systems that make up the LCS SUW MP.

Table 2 LCS SUW MP Mission Systems (after Schoenster 2008)

Mission Systems	Quantity
Gun Mission Module	
30mm Automatic Cannon	2
Surface-to-Surface Missile Module	
Launchers	3
Missiles	45
Aviation Module	
MH-60R Helicopter	1
Vertical Takeoff Unmanned Air Vehicle (VTUAV)	2
Maritime Security Module	
11m rigid-hull inflatable motorboat	2
Berthing Modules with gear storage	2
Head/Shower Module	

2. Anti-Submarine Warfare Mission Package

Operating in direct support of a CSG or ESG, or as part of a forward-deployed group, the LCS ASW MP concept is to rapidly deploy and monitor multiple distributed sensors and to employ unmanned vehicles and other off-board systems networked to a common undersea picture to detect, classify, track, and engage target submarines. The LCS will play a significant role within all three task force ASW functional components, specifically:

- Hold at risk potential threat submarines throughout the theater of operations
- Ensure the protected passage of friendly maritime forces and re-supply shipping along sea lines of communication and transit lanes
- Maintain a maritime shield that will deny submarine access to any seabase or operating area being employed by CSGs or ESGs.

In conducting these ASW missions, the LCS will leverage multiple distributed sensors and utilize a host of unmanned and manned off-board vehicles to form a large, well-coordinated acoustic and non-acoustic sensor/weapon footprint. The LCS ASW MP will employ anti-submarine and anti-torpedo self-defense techniques and technologies. Signature-control techniques will provide the added advantage of lowering the probability of detection of the LCS by an enemy torpedo. Table 3 shows the mission systems contained in the LCS ASW MP.

Table 3 LCS ASW MP Mission Systems (after Schoenster 2008)

Mission Systems	Quantity
ASW Escort Module	
Variable Depth Sonar	1
Multi-Function Towed Array Acoustic Receiver	1
Sonobuoys	1
Torpedo Defense Module	
Warning: MFTA with Acoustic Intercept	1
Countermeasures: Light Weight Tow	2
MK 54 Torpedo	
Aviation Module	
MH-60R Helicopter with Airborne Low Frequency Sonar	1
VTUAV	2
Unmanned Vehicle	
USV Towed Array Systems	2
USV Dipping Sonar	1
Remote Multi-Mission Vehicle	2

3. Mine Countermeasure Mission Package

As part of the MCM MP, unmanned vehicles and MH-60S helicopters will hunt the water column to accurately detect and identify mines in the targeted operating area. When required, MH-60S helicopters, USVs, or explosive-ordnance detachment personnel will conduct sweeping and/or neutralization operations of identified mines. If missions do not include mine-hunting operations, MH-60S helicopters and USVs will conduct influence-sweeping operations in intended operating areas. The LCS will incorporate signature-reduction design and signature-management technology to maximize the ship's ability to operate in littoral areas. The LCS ability to control its acoustic and magnetic signatures will improve combat effectiveness significantly and be a major advantage over current warships. The combination of manned and unmanned vehicles allows organic MCM operations to be conducted around the clock. Table 4 shows the mission systems contained in the LCS MCM MP.

Table 4 LCS MCM MP – Mission Systems (after Schoenster 2008)

Mission Systems	Quantity
Remote Minehunting Module	
AN/WLD-1(V) Remote Multi-Mission Vehicle	2
Mine Hunting Sonar	3
Near Surface Detection Module	
Airborne Laser Mine Detection System	1
Airborne Mine Neutralization Module	
MH-60S	1
Airborne Mine Neutralization System	1
Coastal Mine Reconnaissance Module	
Coastal Battlefield Reconnaissance and Analysis System	1
VTUAV	2
Unmanned Mine Sweeping Module	
USV	1
Unmanned Surface Sweep System	1
Buried Mine Hunting Module	
Surface Mine Countermeasure Unmanned Underwater Vehicle	2

4. LCS Concept of Employment

The concept of employment for the LCS ship class is to operate multiple platforms as SAGs configured to conduct a single focused mission (for example, two to three LCS platforms configured to conduct the SUW mission). Similarly, the ships may be formed-up in a SAG comprised of four to six ships operating together and providing mutual support but configured as a group to execute two or three focused missions (i.e., two ships configured for MCM, two ships configured for ASW and two ships configured for SUW or another mission). The senior LCS commanding officer serving as SAG commander will exercise command and control from designated command and control centers.

The operational and tactical control of the LCS, whether operating as part of a surface action group or in company with a CSG or ESG, will follow the same traditional organizational command and control structure customarily used in today's fleet forces (U.S. Navy 2004). "An ESG combines an ARG/MEU with the combat power of surface

and submarine combatants” (Hutchins et al. 2005, 3). Based on this existing definition, an ARG deployed with an LCS or LCS squadron would be considered an ESG.

Figure 5 shows how the LCS will be employed with a CSG/ESG. When deploying as part of a CSG or ESG, the strike group composition will include two to three LCS-class ships. The LCS platforms will execute specific missions that have been determined a threat from the commanding officer of the CSG or ESG. As the CSG and ESG continue its primary mission, the LCS conducts operations in confined waters in advance of the CSG/ESG (U.S. Navy 2004).



Figure 5 LCS MPs Diagram (from Lockheed Martin n.d.)

E. PROBLEM STATEMENT

The ARG operates independently without the support of a SAG. As a result, MEU operations requiring joint fires necessitate the deployment of a SAG in order to support the ARG during amphibious operations. Deployment of a SAG to support amphibious operations is not always feasible due to a limited quantity of naval platforms capable of providing surface fires and the need for those platforms to conduct other operations (e.g., ballistic missile defense, anti-air warfare, and undersea warfare).

Further, the platform intended to supplement the existing fleet of surface fires platforms, the Zumwalt class destroyer, has been cut from delivery of 32 platforms to a total of only three platforms. This decision exacerbates the capability gap associated with the ability to provide joint fires in support of amphibious operations.

With these facts in mind, as well as the joint fires capability gaps discussed above, this project considers the following problem statement:

The ARG lacks the adequate capability to employ fires and perform ISR&T data collection in support of amphibious operations.

The LCS CONOPS describes the LCS platform operating in the amphibious theater of operations. The LCS platform is the only surface combatant designed specifically for the littorals—its support of amphibious warfare is an obvious consideration. Further, in a letter with the subject “USMC Integration with Freedom—Variant Mission Modules,” Commander Wilke lists nine potential amphibious mission areas for LCS that provide insight into how LCS can fulfill current gaps in amphibious warfare (AMW):

- Launch small USMC force to conduct an amphibious raid
- Launch pre-assault beach survey teams
- Launch special operations forces
- Conduct close in gunfire support using electro-optical/infrared (EO/IR)-targeted 57 mm smart fused rounds at a rate of 200 rounds per minute.
- Deliver humanitarian assistance supplies.
- Support humanitarian aid and disaster relief as fast ferry to transport victims from shore to amphibious shipping.
- Support noncombatant extraction operations as a fast ferry from shore to amphibious shipping.
- Provide real time airborne surveillance utilizing the MH-60 helicopter and Firescout VTUAV with their associated EO/IR and electronic support sensors and data links.
- Provide helicopter-launched Hellfire missiles to support amphibious forces ashore. (Wilke 2014)

In order to address the problem statement listed above, and given the aspects of LCS discussed above, this project focuses on answering the following research questions:

- What threats exist for an ARG/MEU during amphibious operations?
- What alternatives exist for providing joint fires capability with a LCS mission package?
- Could LCS provide effective joint fire support?
- What would the most cost-effective LCS mission package be to support amphibious operations?

F. SYSTEMS ENGINEERING PROCESS

In order to answer the questions listed above, this project

- Evaluated existing documentation to identify capability gaps associated with amphibious operations,
- Developed a design reference mission (DRM) in order to characterize the environment in which the potential solutions would operate,
- Identified the operational requirements necessary for the system to adequately support amphibious operations,
- Developed the operational, functional, and physical architecture of potential solutions to meet the defined capability need,
- Identified the measures of effectiveness (MOEs) to be used in evaluating the potential solutions,
- Built a discrete-event model to evaluate the effectiveness of the potential solutions in terms of the identified MOEs,
- Generated cost estimates for each of the potential solutions, and
- Performed an analysis of alternatives of the potential solutions to identify the most cost-effective solution.

The first step (identify capability gaps from existing documentation) was performed via research, as discussed above, and informed the decision to focus on joint fires and ISR&T operations. The remainder of this paper discusses the methodology and results of the subsequent steps.

This project applied a tailored system engineering (SE) process to analyze the potential solutions for this multi-faceted problem. After considering the many different ways to approach a problem that affects all services in the DOD, it was determined the

SE process would best serve the project’s objectives by focusing on the phases and deliverables shown in Figure 6.

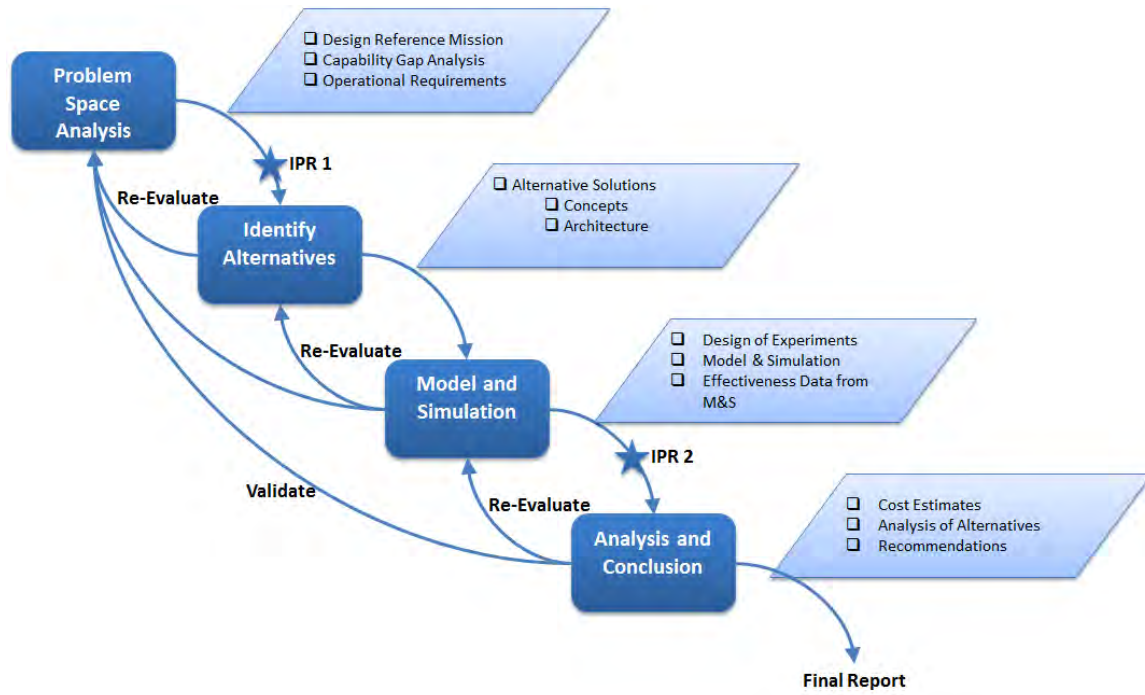

Figure 6 Tailored Systems Engineering Process

The first phase of the tailored SE process focused on the problem presented above. This phase included identifying the existing capability gaps and describing the operational situation(s) associated with the use of the LCS in amphibious operations. This phase resulted in the generation of a capability gap analysis, DRM, and operational requirements. This phase identified existing gaps documented in existing literature, and established the MOEs of the potential solution.

The developed DRM and operational requirements were then used to identify alternative solutions. In this phase, alternative designs that address the problem and meet the needs described in the first phase of the process were developed through functional analysis and allocation. The developed architectures were used in the following steps for assessing the effectiveness of the proposed solutions.

The third phase of the process was modeling and simulation. This phase evaluated the proposed solutions against the MOEs identified during the first phase. Models and simulations were used to evaluate proposed architectures and obtain metrics as defined by a design of experiments. The collected metrics supported the overall analysis of alternatives performed during the next phase.

The final phase of the tailored SE process included cost estimation and an analysis of alternatives, using cost as an independent variable, to identify the best value solution to the specific capability gaps identified in the first phase.

THIS PAGE INTENTIONALLY LEFT BLANK

II. SYSTEM CONTEXT

In order to understand the operational context of the proposed solution (i.e., an LCS AMW MP (LAMP)), this project considered the navy tactical tasks required to be performed by a LAMP and developed a DRM to describe the environment in which the LAMP would be expected to operate. Operational requirements were then defined based on the environment described in the DRM.

A. NAVY TACTICAL TASKS

The Universal Naval Task List (UNTL) “provides a common language that commanders can use to document their command warfighting requirements as mission essential tasks” (U.S. Navy, USMC, USCG 2007, 2). For this project, the UNTL was used to further characterize the identified capability gaps due to its consistency and acceptance for describing the DoN operational activities. As part of this process, each capability gap discussed above (i.e., ISR&T data collection and fires employment) was analyzed to identify the naval tactical activities (NTAs) that must be performed in order to address the given gap.

The Unmanned Systems and Surface Fires ICDs, as well as the POM-16 MCGL, document capability gaps related to NTA 2 “Develop Intelligence.” The documented gaps relate to real-time monitoring of the battlespace, collection of targeting data in support of direct and indirect fires, and dynamic reallocation of ISR&T assets. In general, these gaps most closely align with the performance of collection operation and management (NTA 2.2), the conduct of analysis and production of intelligence (NTA 2.4), and the dissemination and integration of intelligence (NTA 2.5).

The ICD for Joint Fires specifically relates to the employment of fires in support of joint operations, directly related to NTA 3 “Employ Firepower.” Specific to the documented gaps, the required NTAs relate to the application of firepower against ground targets. Key activities employed during the fires mission are the abilities to process and attack targets. Target processing (NTA 3.1) includes the identification and selection of land targets and the selection of appropriate use of firepower systems.

Attacking targets consists of engagement of the enemy in which assets will destroy, degrade, or disable targets using all available organic firepower. Attacking targets (NTA 3.2) will consist of all lethal and nonlethal actions, both defensive and offensive.

The identified NTAs serve as a starting point for describing the system context. The remainder of this chapter further decomposes the identified NTAs to more specific operational activities that the final solution may perform to address the identified capability gaps. This decomposition is primarily accomplished through the development of the system's DRM.

B. DESIGN REFERENCE MISSION OVERVIEW

A DRM was depicted utilizing a joint phased campaign scenario. This approach was chosen in order to characterize the environment and better understand the activities to be performed by a LAMP during amphibious operations. The number of LCS platforms forward deployed in support of the ARG is assumed to be three; this research effort makes the further assumption that all three LCS platforms will have the same AMW mission package installed.

The DRM for the LAMP was built around the existing "Treasure Coast" scenario that is used for both the Bold Alligator series of MEB/ESG trainings exercise and for the ARG/MEU certification exercises used for deploying East Coast ARG/MEUs. The DRM focuses on the phase one (Deter) and phase two (Seize the Initiative) of an amphibious operation, during which the LAMP is expected to provide direct support of an ARG/MEU providing tactical control (TACON). The five phases of an amphibious operation are shown in Figure 7.

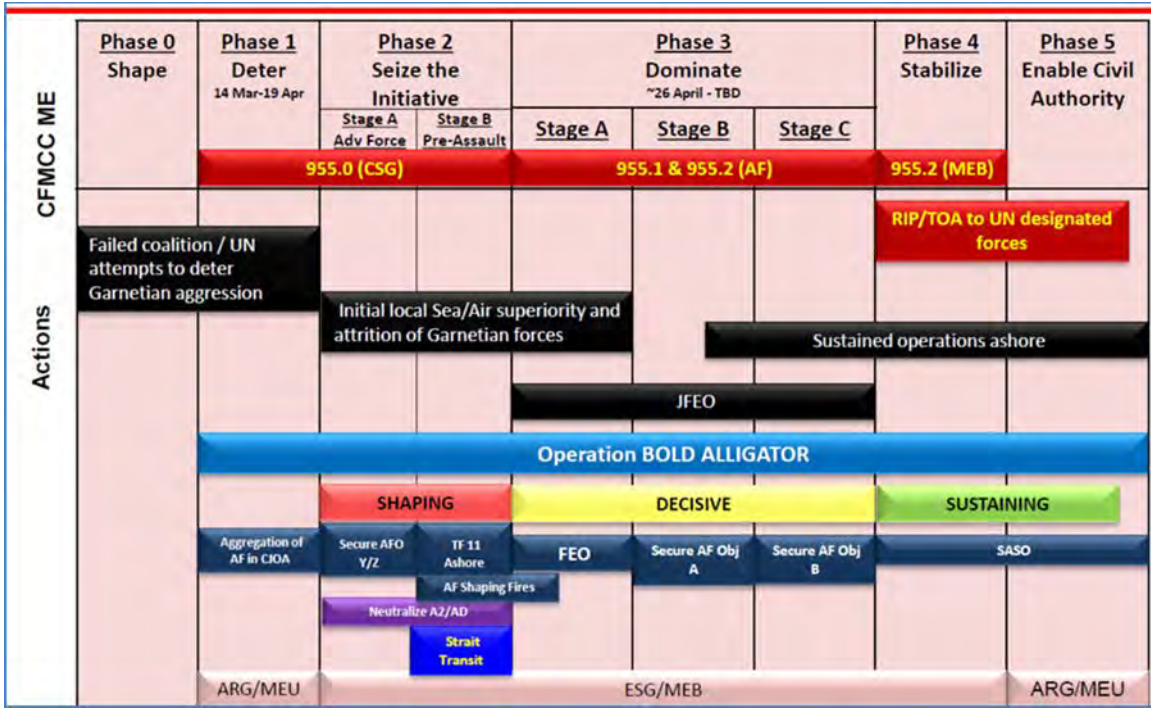

Figure 7 Phases of an Amphibious Operation (from Riccio 2013)

While an ESG and MEB assume control of the main effort during phase three of an amphibious operation, the ARG/MEU remains a separate maneuver element. As a separate naval task force, the forward deployed ARG/MEU remains a separate naval task force under the Joint Force Maritime Component Commander. In direct support to the ARG/MEU, the LAMP will provide its own TACON during the amphibious raid with limited or no additional forces.

The operational situation (OPSIT) of the LAMP DRM consists of an amphibious raid mission in order to explore the identified fires employment and ISR&T data collection capabilities gaps under consideration. Upon arrival of the ARG/MEU in phase 0 of the amphibious operation, ISR&T operational planning will take place between all ISR participation planners and naval commanders. This planning will account for all available assets and will address intended routes/zones, responsible intelligence data processor(s), and the responsible dissemination organization(s). During this time, some organic ARG/MEU assets will provide immediate area reconnaissance in support of ARG/MEU protection.

As phase one of the amphibious operation is initiated, the ISR&T assets will perform forward operations at the coastline and further in to the hostile area. ISR data collection will include a multitude of information for assault planning, such as coastal surf conditions, reinforced coastal emplacements, enemy anti-access and aerial denial (A2AD) systems, and enemy troop size estimates and locations. The assumed area of responsibility during this search is estimated at 10,000 square nautical miles.

At the initiation of phase 2, the ISR&T assets will continue collecting ISR&T data in support of threat engagement. During this phase, the LAMP is also expected to engage targets based on targeting data received from ISR&T assets organic to the LAMP as well as data received from off-platform.

1. Concept of Operations

The LAMP DRM consists of a vertical and horizontal slice of live operational forces involved during amphibious operations, consisting of a MEU LF operation center, ARG supporting arms coordination center (SACC), and LCS squadron command. The LCS squadron consists of three LCS platforms configured with AMW MPs. For the MEU, a reinforced Marine Battalion Landing Team serves as the ground combat element. The maneuver element of the MEU consists of one rifle company, flown in by twelve MV-22s. The rifle company is a mechanized Marine infantry company in twelve amphibious assault vehicles. The rifle company is the primary force the LAMP must provide fire support for both before and during the maneuver.

2. Projected Operating Environment

The POE is the environment in which the system is expected to operate. This section provides details that describe the environmental conditions, types of locations, and threats for which the LAMP must be designed to meet the desired operational capabilities. The POE establishes a context within which operational tasks are expected to be executed by the potential solution in order to define measurable outcomes in support of making design decisions.

a. *Environmental Conditions*

Fire support systems are expected to support operations throughout the spectrum of conflict “during ideal and restricted weather, terrain and [rules of engagement] conditions” (U.S. DOD 2005, 6). The LAMP is expected to operate in:

- Littoral environments with sand barrier islands and intracoastal waterways,
- Sea state one to three, or up to the limits of amphibious operations for both air and surface connectors,
- Daytime and nighttime conditions, and
- Temperatures greater than -40° F and less than 140° F.

b. *Assumed Threat General Conditions*

For the LAMP DRM, enemy forces have crossed the North Garnet border southward into Amberland in an attempt to perform a hostile takeover of the Amberland capital, air terminal, and seaports. Enemy forces occupy most of Amberland as well as the Amber Territory, to the south of Amberland. Force strength in the Amber Territory is estimated to be sparse; larger enemy numbers and mechanized forces are believed to mainly remain in Amberland. Though both Amberland and Amber Territories are not considered to be allies, the U.S. believes that this hostile act is detrimental and disruptive on a much larger scale. Figure 8 depicts the political geography of the POE.

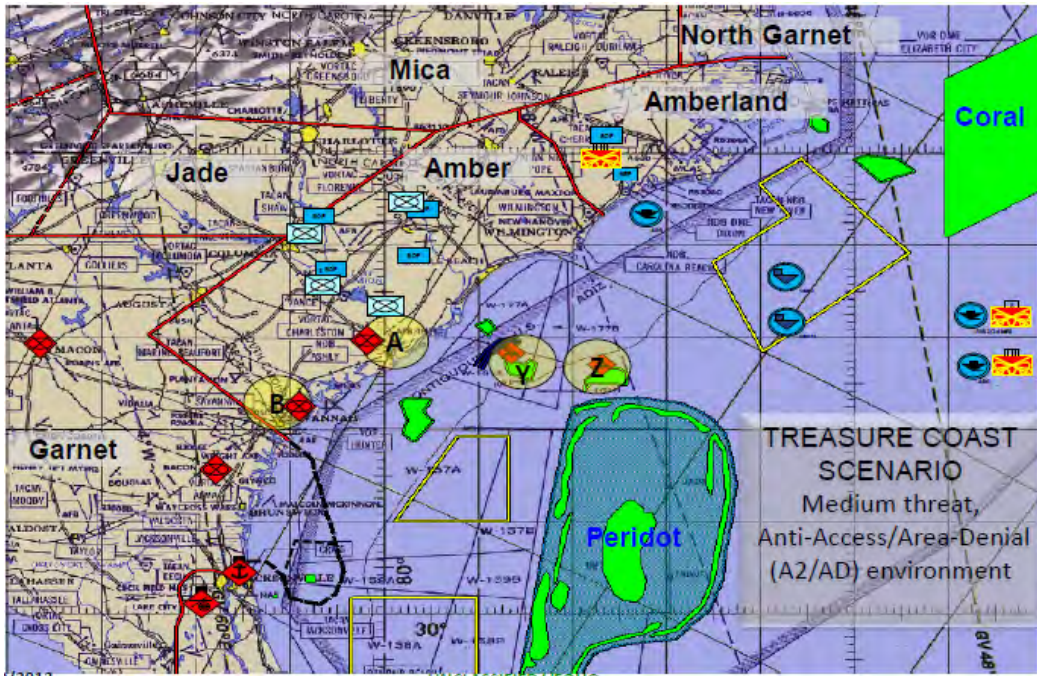

Figure 8 Situation Map from Exercise Bold Alligator (from Riccio 2013)

At the Garnet coastline (south of Amber) and the southern Amber coastline, the enemy will employ A2AD systems, particularly air defense systems, with the objective to prevent the deployment of U.S. forces into the area of responsibility (AOR). In Amberland and the northern portions of the Amber territory, enemy A2AD capabilities are not fully deployed. A2AD systems will interfere with the freedom of maneuver of any aviation assets used for ISR&T, fire support, or transport. Identification of these A2AD systems is the priority during ISR&T operations, and these will be high priority targets in fire support operations prior to deployment of the rifle company in order to ensure that the rifle company can successfully maneuver within the AOR.

Further, an enemy mechanized infantry brigade, as the lead and advance elements of an associated mechanized corps, has reached into Amberland territory. The enemy forces are expected to employ Russian ground combined arms tactics, coupled with the employment of special operations, to shape the environment throughout Amberland and the Amber territory. Combined arms tactics consist of the appropriate combinations of two or more arms elements, such as ground forces, air elements, offensive and defensive

fire support in a unified action. Table 5 shows the major elements of the mechanized infantry brigade, estimated between 3000–5000 enemy personnel.

Table 5 Elements of the enemy mechanized infantry brigade

13 Mechanized Corps				
Division	Brigade	Battalion	Location	Equipment
	1st Mechanized Infantry Brigade			
		Reconnaissance Co		M-1985/Type-62/PT-76M
		1st Mech Infantry BN		BMP-2
		21st Motorized Infantry BN		BTR-90
		22nd Motorized Infantry BN		BTR-90
		23 Motorized Infantry BN		BTR-90
		17th Armor BN		T-80
		1st Artillery BN		152mm SP
		2nd Artillery BN		122mm SP
		28th MRL Artillery BN		122mm Truck-mounted rockets
		1st AAA BN		SA-6 UNK AA System ZPU-23

Figure 9 illustrates the terrain coastline where the ARG/MEU amphibious operations will occur. Objective one is an airfield capable of supporting heavy transport, bomber, and tactical aircraft. Also shown in Figure 9 are the other primary objectives for the MEU raid force: objective two comprises of the marine shipping terminal and objective three consists of a medium length runway capable of supporting additional aerial assets. The yellow hexagon included in Figure 9 depicts the city of Jacksonville, the Amberland capital -- which significant enemy forces are expected to occupy. The LAMP is expected to support the MEU force performing an amphibious raid on objective one, but the presence of other objectives and tactical operations in the vicinity will require coordination and communication to prevent fratricide and effectively support desired operations.



Figure 9 Terrain Sample for the “Treasure Coast” (Intlink Photo)

c. Threat Approach Variants

Threat approaches aimed against the LAMP, including any associated aviation assets, include:

- Air attack,
- Surface attack,
- Anti-ship missile attack,
- Rockets, artillery and mortars,
- Sea mines, and
- Electronic warfare and cyber-attack.

Threats approaches aimed against the ARG/MEU include the above threats plus:

- Enemy ground forces listed in Table 5 and

- Enemy special operations in four- to ten-man elements employing ambushes and controlling supporting arms

3. Mission Success Requirements

For this DRM, mission success requirements of the LAMP include:

- The LAMP shall provide ISR&T capabilities that aid in the successful execution per the specific tactical mission in the OPSIT.
- The LAMP shall provide fires capabilities (both naval surface fires and aviation fires) that aid in the successful execution per the specific tactical mission in the OPSIT.

Specific MOEs for the LAMP system include:

- MOE 1: Percent of targets identified in four hours
- MOE 2: Time between system receipt of fire mission and target impact
- MOE 3: Percentage of targets successfully affected

In order for the mission to be considered successful, the above requirements must be met. To further scope this analysis, these mission success requirements will be assessed in the context of specific mission threads of the particular OPSIT.

4. Mission Definition

Joint Capability Areas (JCAs) provide the operational context for more specific military functions that apply broadly across the range of military operations. In order to help with the selection and modeling of the necessary LAMP operational activities, the JCAs associated with the LAMP (as required by the DRM) were documented. Table 6 shows the appropriate first two tiers of the JCAs, with areas directly related to the LAMP highlighted.

Table 6 Joint Capability Areas Applicable to the LAMP (after U.S. DOD 2011)

#	Tier 1	Definition	Tier 2 JCA
2	Battlespace Awareness	The ability to understand dispositions and intentions as well as the characteristics and conditions of the operational environment that bear on national and military decision-making.	Intelligence, Surveillance and Reconnaissance Environment
3	Force Application	The ability to integrate the use of maneuver and Battlespace Awareness engagement in all environments to create the effects necessary to achieve mission objectives.	Maneuver Engagement
4	Logistics	The ability to project and sustain a logistically ready joint force through the deliberate sharing of national and multi-national resources to effectively support operations, extend operational reach and provide the joint force commander the freedom of action necessary to meet mission objectives.	Deployment and Supply Maintain Logistic Services Operational Engineering Installations
5	Command and Control	The ability to exercise authority and direction by a properly designated commander or decision maker over assigned and attached forces and resources in the accomplishment of the mission.	Organize Understand Planning Decide Direct Monitor

In order to identify the activities required to support LAMP mission success, the identified capability gaps were traced to the JCAs, and the JCAs were traced to the operational activities required to accomplish those capabilities. This matrix between capability gaps, JCAs, and operational activities, documented as the LAMP CV-6, is provided as Appendix B.

The LAMP operational activities were developed based upon the NTAs discussed in the previous section. The following high-level operational activities, based on the top-level activities of the UNTL, were allocated to the LAMP during the development of this DRM. The top-level operational activity is the parent of the first level activities.

Top Level Operational Activity:

- OA.0 Conduct AMW Support for the ARG/MEU

First Level Operational Activities:

- OA.1 Deploy/Conduct Maneuver, which includes deploying and maneuvering the assets required for ISR&T and fire support
- OA.2 Develop Intelligence, which includes the collection and processing of combat information and intelligence products to provide ISR&T data
- OA.3 Conduct Fire Support, which includes the actual fire support activities
- OA.4 Perform Logistic and Combat Service Support, which includes any activities required to sustain the LAMP, including fueling assets, loading and reloading ammunition, and performing any necessary preventive or corrective maintenance
- OA.5 Exercise Command and Control, which includes controlling any mission package assets deployed off of the platform, providing collected information and intelligence to those who require it, and communicating fire mission status

5. Mission Execution

While fire support and ISR&T data collection are required to be employed across the full spectrum of operations, the LAMP DRM was designed to assess a subset of the required mission capabilities in the context of certain missions executed during amphibious operations.

Figure 10 represents a high-level operational view of the LAMP. During operations, the LAMP is employed in direct support of the ARG/MEU. The LAMP includes assets that detect threats and provide situational awareness in the littoral operating area. If and when the AOR is determined to be clear of enemy threats, the LAMP continues to search for emergent threats within the AOR. The LAMP provides an extension of current ARG/MEU assets and alerts operators and commanders of potential threats in the area before, during and/or after deployment of water-borne and aircraft-borne assets into the AOR. The LAMP also supports amphibious operations with direct fire support and provides ARG/MEU commanders with organic fires capability. The LAMP provides support for mission planning, planned fires, the identification and

engagement of targets of opportunity, quick response surface fires, and post engagement assessment.

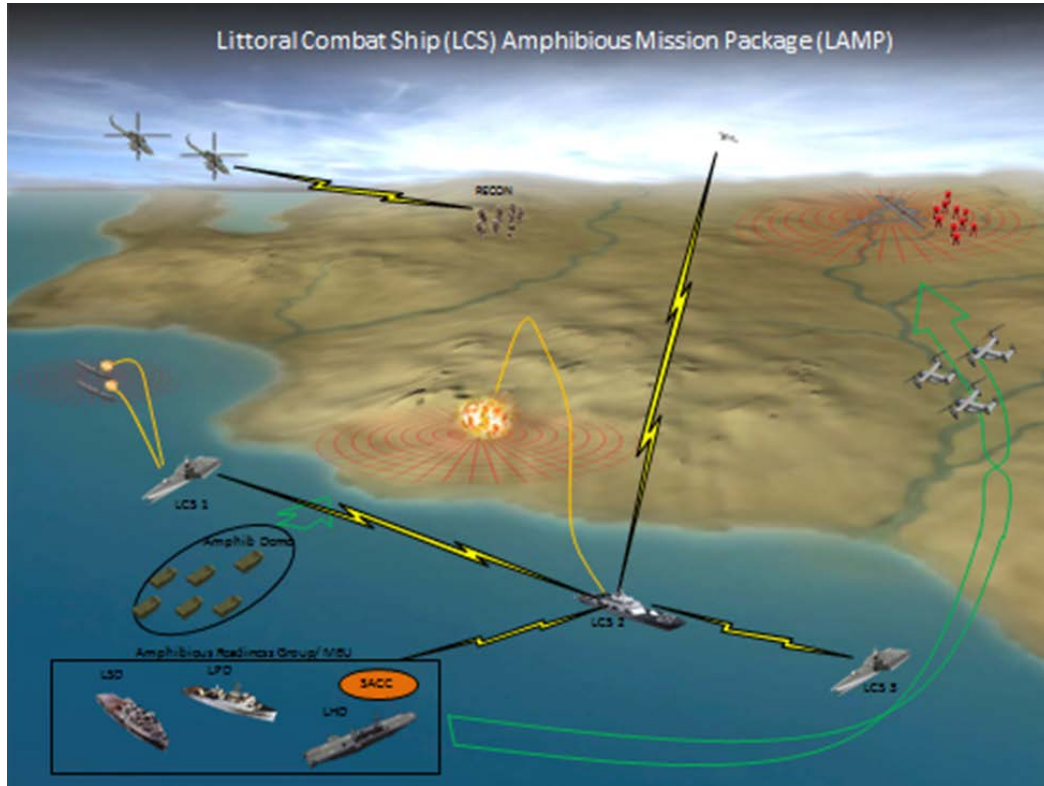

Figure 10 LAMP High Level Operational Concept Graphic (OV-1)

6. Amphibious Raid OPSIT

For the OPSIT, the enemy mechanized infantry brigade main body is located at Jacksonville in order to maintain control of major supply transportation routes. Enemy company-sized elements surround objectives one and two. The enemy company elements consist of ten troop carriers, four tanks, and shoulder-launched man-portable air defense systems. Motorized anti-air asset locations are currently unknown within the AOR.

Both the amphibious raid and amphibious demonstration will be supported by close air support and NSFS to the fullest extent possible. Possible missions for LAMP during the conduct of operations by the ARG/MEU include:

- Provide fire support and ISR&T data collection in support of the amphibious raid

- Provide fire support and ISR&T data collection in support of a tactical recovery of aircraft and personnel mission, in the event an air asset is shot down or crashes during the primary mission
- Provide fire support and ISR&T data collection in order to prevent any enemy armored counterattack against the MEU raid force during or after their seizure of objective one

C. OPERATIONAL REQUIREMENTS

Operational requirements describe the identified capabilities and the associated needs of the system and identify the essential capabilities, performance measures, and processes needed to address the mission. The LAMP operational requirements are based on the capability gaps, JCAs, and operational requirements discussed in the previous section. Objective and threshold values of the LAMP operational requirements are based on the Joint Fires ICD, Unmanned Systems ICD, and the environment described in the DRM.

Two capability gaps associated with fires support were identified in the Joint Fires ICD. The first gap identified is the ability to engage known and/or identified targets when friendly forces are in close contact or when collateral damage is a concern. The second gap identified the ability to provide fires to achieve volume effects. These capability gaps include the sustained rate of fire, probability of damage, and range.

The Joint Fires ICD listed specific MOEs for providing fire support, with desired minimum values included. Acquisition programs of record that provide fires support capabilities require varying ranges and rates of fire; the LAMP operational requirements associated with fires support are based on the specific MOEs from the Joint Fires ICD.

1. The LAMP shall provide joint fires in support of amphibious operations.
 - The LAMP shall have a sustained rate of fire of five rounds per minute (T); 10 rounds per minute (O).
 - The LAMP shall have a 40% (near term) Probability of Damage (PD) against targets (T); 70% (long term) Probability of Damage (PD) against targets (O).
 - The LAMP shall have an engagement range of 13 nautical miles (mid-term) (T) and 110 nautical miles (mid-term) (O).

The ISR&T NTAs were analyzed to identify the operational requirements associated with the ISR&T-related capability gaps and JCAs described in the DRM. The NTAs associated with the ISR&T JCAs are most accurately described in terms of operational range; the geography of the AOR described in the DRM was used to identify threshold and objective ranges for LAMP ISR&T capabilities.

2. The LAMP shall perform intelligence, surveillance, and reconnaissance support of amphibious operations.
 - The LAMP shall conduct reconnaissance at a range of 50 nautical miles (T) 100 nautical miles (O).

The LCS platform is limited and can only house a limited amount of assets that will fit on the platform safely and securely, while taking account the operational environment. The LCS interface control document details the requirements and constraints levied on a LCS MP.

3. The LAMP shall meet the requirements of the LCS interface control document

III. FUNCTIONAL ANALYSIS AND ALLOCATION

With the system context described by the DRM and operational requirements, the project focused on further development of the LAMP operational architecture, definition of the required functional architecture, and identification of the potential physical architectures of the LAMP. These artifacts were developed through functional analysis and allocation, as further described in this chapter.

Functional analysis is an iterative process of translating high-level system capability requirements into progressively more detailed design requirements. This process develops the top-level system architecture, which deals with both requirements and structure. The purpose of functional analysis is to present an overall integrated and composite description of the system's functional architecture, to establish a functional baseline for all subsequent design and development activities, and to provide a foundation for the system's physical architecture (Blanchard & Fabrycky 2011).

The functional analysis approach to system refinement helps ensure that all facets of system design and development for the entire system life cycle are considered; all required elements of the system are recognized and defined, including elements that exist for support, maintenance, production, disposal, and other non-tactical uses; a means exists to relate support requirements to specific system functions, satisfying the requirements of a good functional design and ensuring that features and requirements are included where necessary and not where unnecessary; proper sequences of activities, design relationships, and critical interfaces are established; and there is traceability from the system capability need and top-level requirements down to detailed system, subsystem, and element functional requirements (Blanchard 2008).

Functional allocation is the process by which closely related system functions are grouped into packages employing a common resource, with each "package," or system element, as independent as possible (Blanchard & Fabrycky 2011), ultimately assigning the required functionality to the required physical elements of the system. This effort continues to decompose the system elements down to the lowest level practical. As

applied to the LAMP, this decomposition process continued to the point at which existing systems could be evaluated for their potential to perform required functionality without artificially constraining the potential options because of how functionality was grouped and allocated.

A. METHODOLOGY OVERVIEW

The process of functional analysis and allocation is the central portion of the “Identify Alternatives” block in the tailored systems engineering process approach selected for this project. The SE process, described in Chapter I, Section F, identifies several key items, particularly the capability gap analysis, DRM, and operational requirements developed in the previous step, that are necessary inputs to functional analysis and allocation. The SE process also indicates the expected outputs of this effort—i.e., alternative solutions and the architecture of those alternatives.

Functional analysis began with the capability gaps identified by the capability gap assessment. As was discussed in earlier chapters, the capability gaps were traced to capabilities and to NTAs (i.e., the LAMP operational activities) in order to capture the specific tasks required to meet the capability needed. This was captured as part of the DRM refinement.

The LAMP operational activities were, in turn, used to derive the LAMP system functions; system functions were then traced to operational activities to ensure complete coverage of the activities identified as part of DRM refinement and operational architecture development. System functions were then grouped and allocated to system elements, which are specific hardware, software, firmware, and human operators that perform the functions in question. Further definition, refinement, or decomposition of capabilities, operational activities, system functions, and/or system elements drove corresponding feedback and changes to other portions of the architecture; development of the system architecture was an exercise in iteration and feedback. As the architecture was decomposed, each area was reexamined and feedback incorporated to ensure the architecture remained self-consistent.

B. ARCHITECTURE TOOL AND LANGUAGE SELECTION

Architecture tools allow the system architect to enforce formal rules of architecture development and ensure consistency across views and viewpoints (Giammarco 2010). For this effort, an architecture tool was required to (1) support simultaneous, collaborative work amongst geographically distributed individuals, (2) provide Department of Defense Architecture Framework (DoDAF) v2.0 views, (3) allow simple import and export of data, and (4) allow tailoring of the schema. Based on these criteria, Innoslate (developed by SPEC Innovations) was selected for use.

While Innoslate natively uses Life Cycle Modeling Language, Innoslate's native language was not used. Instead, the Innoslate features to tailor language and label classes were used to implement the desired language. Innoslate is capable of supporting DoDAF views in widely used graphical formats, meaning the tool could still produce desired architecture products.

DoDAF v2.0 definitions of terms and expected relationships between different classes are familiar to the expected audience of this report. As a result, DoDAF was already planned for use in determining and constructing appropriate architecture views to communicate the results of the functional analysis. Further, DoDAF is well suited for capturing the high-level operational and enterprise interactions that are key to expressing how the system under development must operate within the larger context of the ARG/MEU, and DoDAF has classes and relationships that capture the information critical to this system. Therefore, DoDAF definitions were used in the development of the architecture. In order to avoid any confusion between DoDAF definitions of common terms and definitions within other architecture languages readers may be familiar with, Table 7 captures commonly used architecture terms as they are defined within the *Department of the Navy Architecture Development Guide*, and used in the remainder of this report.

Table 7 Definition of Commonly Used Architecture Terms (after U.S. Navy 2011a)

Name	Definition
Capability	The ability to achieve a desired effect under specified [performance] standards and conditions through combinations of ways and means [activities and resources] to perform a set of activities.
Data	Representation of information in a formalized manner suitable for communication, interpretation, or processing by humans or by automatic means.
Entity	An entity is the representation of a set of real or abstract things (e.g., people, places, events, or ideas) recognized as the same type because they share the same characteristics and can participate in the same relationships.
(System) Function	An Activity, Process, or transformation (modeled by an IDEF0 box) identified by a verb or a verb phrase that describes what shall be accomplished. Called System Function in this thesis to distinguish between external functions and other general use of the word function.
Link	A representation of the physical realization of connectivity between Systems or Service.
Needline	A Needline represents the logical expression and documents the requirement of the need to transfer resources and do not indicate ‘how’ the resource is exchanged.
Operational Activity	An Activity is an action performed in conducting the business of the Enterprise. It is a general term that does not imply any place in a hierarchy. It is used to portray operational actions, not hardware/software system functions.
System (Element)	An organized assembly of resources and procedures united and regulated by interaction or interdependence to accomplish a set of specific Functions. Called System Elements in this thesis to clarify that they may be pieces (e.g., subsystems, assemblies, components, parts, or subassemblies) of the system under development.

C. OPERATIONAL CONTEXT

The first step of the functional analysis was to identify all of the external entities and inputs in order to define the boundaries of the system being developed and define the external operating environment. This also allowed the identification of required external interfaces and the data and resources exchanged across these interfaces. By establishing a firm definition of what was external to the system and what must flow in and out, the

functional analysis also significantly refined the initial operational activities derived from the NTAs identified in the DRM. This feedback was then incorporated in the final DRM.

Figure 11 shows a simple diagram of these external interfaces. The first interface is between the AMW mission package and the LCS platform. The LCS platform must provide host services, including power, water, access to networks, and propulsion to the area of the interest. The mission package must also interface with the SACC, which is responsible for coordinating all of the fire support planning for the ARG/MEU operations in this situation. The SACC provides the LAMP with the fire support coordination plan, target lists, fire orders, and confirmation (or at least the option to veto) on firing missions initiated by a direct call for fire. The SACC has the primary responsibility to pair the target with an effective weapon, to the level of assigning a target and fire mission to a particular mission package. The LAMP in return must provide status of the fire mission and health and status of the MP and weapon systems to allow the SACC to make informed decisions about what asset to assign to a fire mission. The joint intelligence center (JIC) is responsible for the collection, analysis, integration, and dissemination of intelligence to the ARG/MEU, including producing an intelligence collection plan and providing operational intelligence requirements to the LAMP. The JIC establishes where the LAMP ISR&T assets should look and what data is desired. The LAMP must provide combat information and processed intelligence products to the JIC.

The LAMP also has external interfaces with hostiles and the external environment. The mission package sends energy, both in the form of active sensor energy and destructive energy from weapon systems, out to the environment and the hostiles in the process of attempting to detect and neutralize hostiles—any energy that misses hostiles is still sent to the external environment. The environment interacts with the LAMP through weather and terrain, which the LAMP detects and may be obstructed by. The hostiles, if they are to be detected, must provide some indication of presence, whether through emissions or simply being visible.

The LCS Squadron (LCSRON) and Military Sealift Command (MSC) are responsible for logistics support, providing both short-term supply replenishment and long term sustainment activities like maintenance and training to the LAMP. The LAMP

must provide a status, particularly a logistics demand signal, to the LCSRON and MSC in order to indicate what support is currently needed.

Lastly, the LAMP will have an external interface with fire controllers, which can include 81 mm mortar forward observers (FOs), artillery FOs, naval gunfire spotters, forward air controllers, joint terminal attack controllers, or any other fire support controller in the area of operations. The fire controllers can provide the LAMP a direct call for fire, which is a special type of fire mission typically requiring a short turnaround time, which would not go through the SACC. In these cases, the SACC nominally must approve the direct call for fire, but in reality, this is usually a case of silence-is-consent. The LAMP provides the status of the fire mission to the fire controller, allowing confirmation that the mission has been successful and adjustment of fires if necessary.

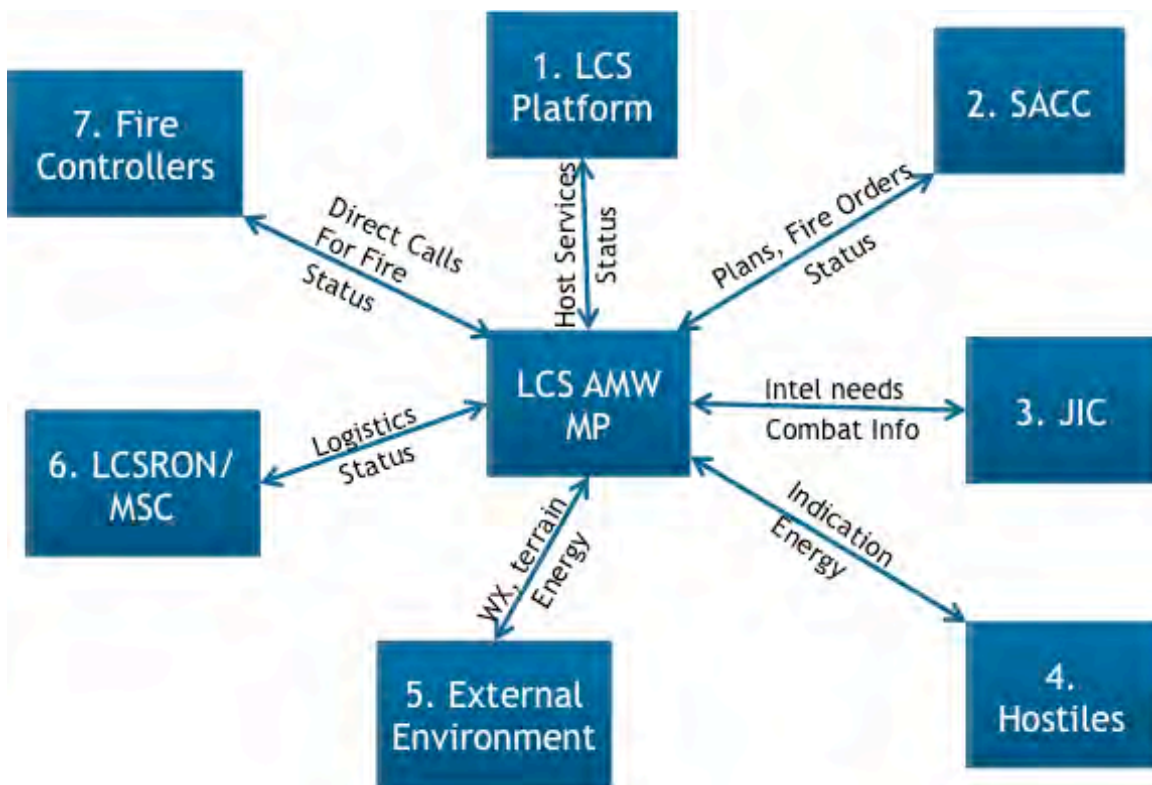

Figure 11 LAMP External Interfaces

D. OPERATIONAL ACTIVITIES

The operational activities previously identified for the capability gaps, refined based upon the more detailed understanding of system boundaries and necked down required capabilities, were also entered into the Innoslate architecture. Once entered, the operational activities were traced to the relevant capability. The inputs and outputs of each operational activity, including controls, were captured. Figure 12 shows the hierarchy of operational activities associated with the LAMP. The following paragraphs describe the operational activities in more detail and capture the data exchanges among the operational activities.

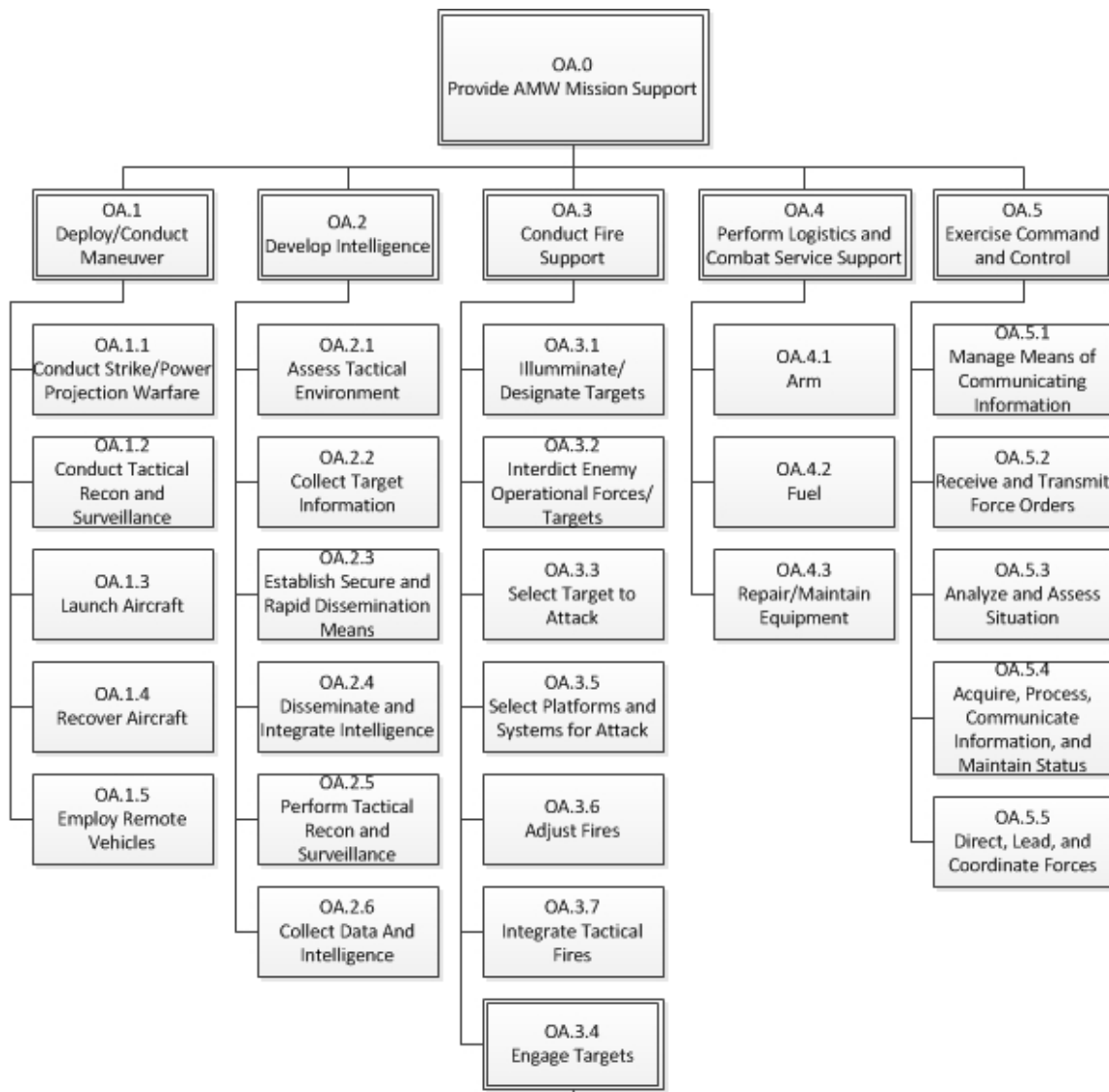

Figure 12 LAMP Operational Activity Hierarchy

Figure 13 shows the IDEF0 diagram of the first level operational activities associated with the LAMP. Note that as the operational activity hierarchy showed, each of the first level operational activities has been further decomposed. As a result, the majority of the inputs, outputs, controls, and mechanisms on the IDEF0 diagram are shown as tunnels. The first operational activity is OA.1, Deploy/Conduct Maneuver, which addresses the activities needed to launch, maneuver, and recover aviation assets that are part of the mission package. It does not include maneuvering the LCS itself—this is assumed to be an external responsibility of the LCS platform. Deploy/Conduct Maneuver receives commands from OA.5, Exercise Command and Control, and fuel and sustainment from OA.4. Deploy/Conduct Maneuver outputs include status information and raw on-site combat information. At this point, these products are not processed intelligence, simply raw information about the aviation assets, including location, status, and situation.

The second operational activity, OA.2, Develop Intelligence, consists of using any sensor systems included in the mission package to gather combat information, including information about environment, terrain, and enemy forces, and then performs some limited processing of combat information in order to provide both intelligence products and combat information for local and external use. Note that per the definitions in JP 1–02, information can only be called intelligence after it has been processed, but that processing can be as simple as a human viewing an image and identifying the subject as a particular variety of tank.

The third operational activity is OA.3, Conduct Fire Support, which handles all of the tasks required to actually shoot hostiles. OA.5, Exercise Command and Control, provides the fire mission information that controls this operational activity, and OA.2, Develop Intelligence, provides inputs of combat information and intelligence products. OA.4, Perform Logistics and Combat Service Support, provides required sustainment and any loading of ammunition required by weapon systems. OA.4 exists for the tactical work of refueling and reloading ammunition, but also allows for maintenance activities required by the system in order to make the other operational activities possible, such as

any sensor calibration or weapon alignment tasks. OA.5, Exercise Command and Control, only addresses LAMP command and control of its own assets.

The SACC will provide the fire support coordination planning, including prioritized target lists, desired effects, and de-confliction of targets and fire support with friendly units and air traffic. OA.5 takes this as an input, along with all of the system status information, and controls the mission package assets in order to accomplish the mission assigned to the LAMP. OA.5 generates commands that are received by OA.1 and OA.3. OA.5 also provides status information as outputs, including acknowledging calls for fire and fire missions assigned by the SACC, providing the status of fire missions to the SACC and the fire controller requesting the fire support, and communicating collected combat information and processed intelligence to the JIC.

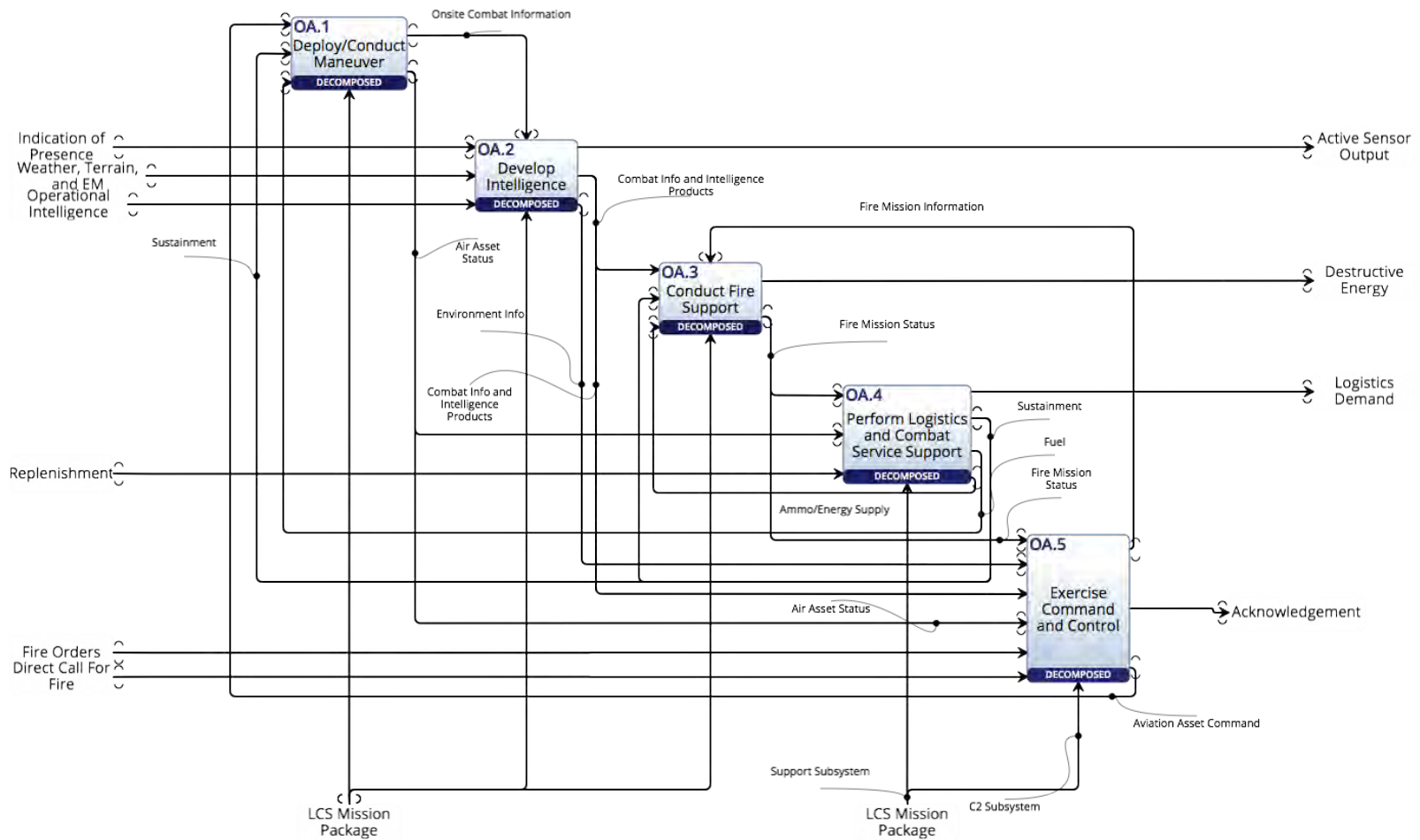

Figure 13 First Level Operational Activities IDEF0 Diagram

E. SYSTEM FUNCTIONS

System functions were identified to implement the operational activities. At the highest levels, the system functions are very similar or identical in wording to the operational activities. However, the lower the decomposition, the more specific the functions become, until they are specific actions implemented in specific system elements.

Figure 14 shows the functional hierarchy for the LAMP. F.1, Maneuver Aviation Asset, includes all of the functionality required to launch, maneuver, employ, and recover an aviation asset. F.2, Develop Intelligence, addresses all of the required sensing to assess the terrain and environment, collect target information, perform reconnaissance and surveillance, process collected information to develop intelligence products, and disseminate those products. F.3, Conduct Fire Support, includes all the functionality required to effectively employ weapons against targets, including designating the targets for engagement, engaging targets directly, interdiction of enemy movements, and adjusting fires to provide desired accuracy. F.4, Perform Logistics, only addresses the efforts the system must take, not the greater logistics and support system external to the LAMP. F.4 includes loading and reloading weapons that expend ammunition, arming or charging systems that use electrical energy rather than ammunition cartridges, fueling and refueling aviation assets, supporting required maintenance operations, and monitoring the logistics status in order to report when maintenance or resupply is required. F.5, Exercise Command and Control, addresses only the system's local command and control of its own assets, not the greater command and control of the overall operation. F.5 includes managing communications between the system and the external interfacing entities shown in the external interfaces diagram, controlling and coordinating the aviation assets that are part of the mission package, assessing status and health of mission package assets, and assigning received fire missions to specific systems within the mission package based upon position and status.

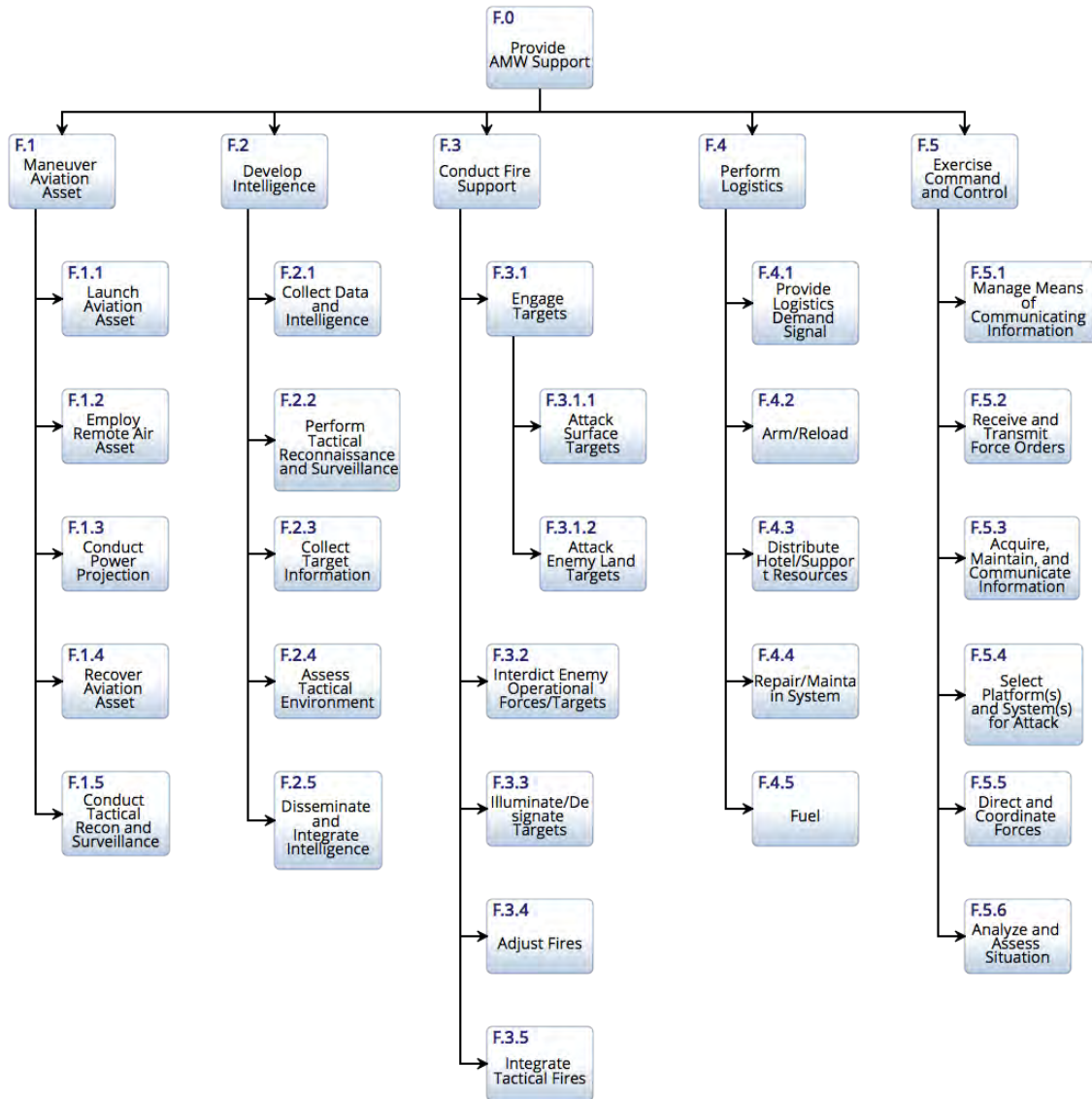

Figure 14 Functional Hierarchy

Figure 15 shows the first level functional flow for the system. At the top-level, this is similar to the operational activity diagram except in enhanced functional flow block diagram (EFFBD) format rather than IDEF0. This EFFBD shows that all of the functions occur in parallel. Data items in green indicate controls for functions, while grey color and lines marked optional indicate that the item is an input. Items that are inputs for one function but controls for another show in grey, with the input lines marked optional. Outputs that are transferred to external functions are also shown in green. In general, items on the left of the diagram are inputs from external functions and items to the right

are outputs to external functions. The internal functions exchange data and resources with each other and external entities. For example, F.4 provides all the logistics required for F.1, Maneuver Aviation Asset, and F.3, Conduct Fire Support, to occur, but both of these functions provide status back to F.4 that allow it to provide a logistics demand signal. Additionally, F.5, Exercise Command and Control, is required to provide commands and fire missions to F.1 and F.3, respectively. F.2, Develop Intelligence, can begin only once an aviation asset is on station and providing onsite combat information, but it provides feedback both external to the system and to F.5, Exercise Command and Control, that would result in new or additional aviation asset maneuver commands and fire missions based upon the data.

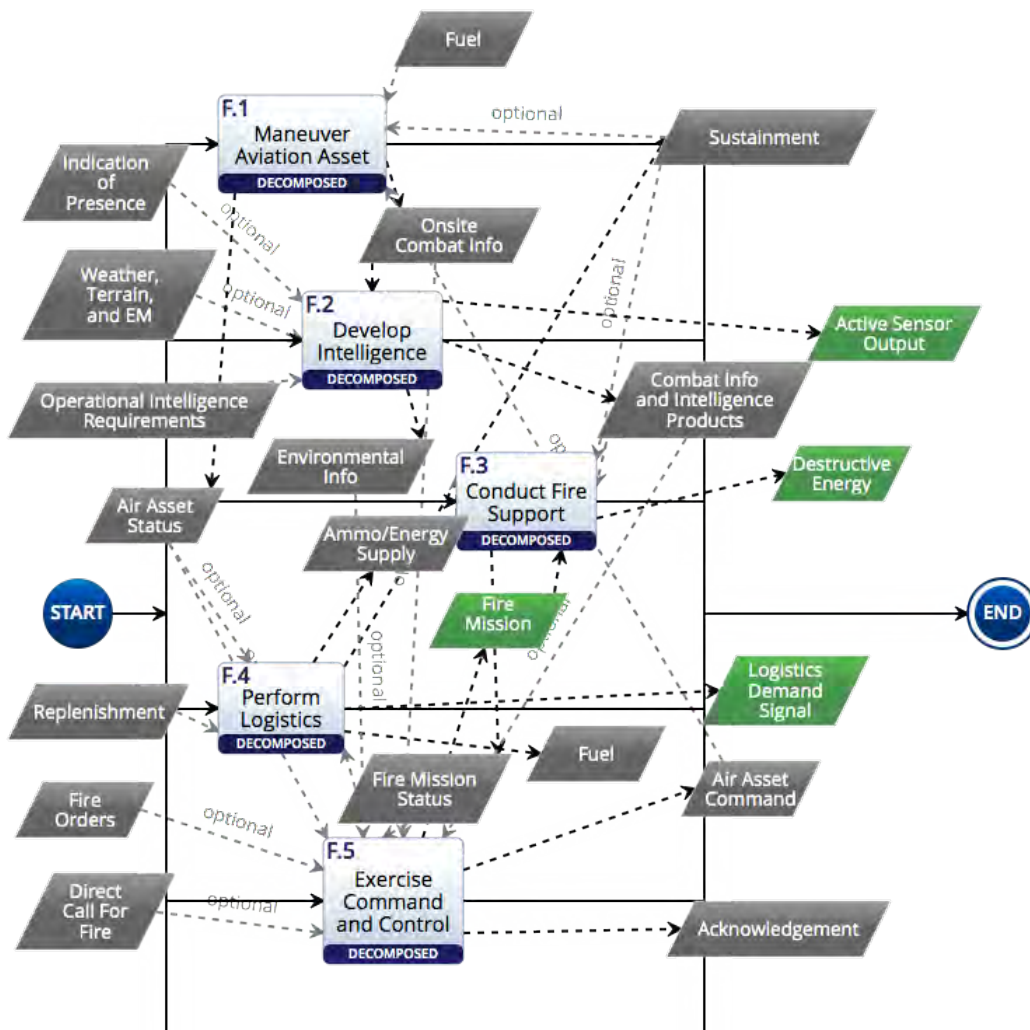

Figure 15 Top-Level Functional Flow

In order to ensure that all the operational activities had system functions to implement the operational activities in the LAMP, a traceability matrix was generated (Appendix C). This also ensured that there were no system functions that did not trace to an operational activity and thus were not required to execute the mission outlined in the DRM. As the comparison of the operational activity and system function diagrams show, at the top level, the operational activities and system functions align well.

F. SYSTEM ELEMENTS

Grouping closely related functions and partitioning the resources required by those functions into system elements created system elements. The hierarchy of system elements is shown in Figure 16. The highest level is the LAMP itself, as this is the system being developed to provide AMW support. From there, the system is broken down into four major subsystems:

- A shipboard weapon system, made up of the weapons themselves and the delivery system, such as a launcher, bomb rack unit, gun, or catapult, required to get the destructive energy to the target;
- An air detachment, which includes the aviation platforms and their onboard sensors and weapons;
- A command and control (C2) subsystem, which provides local mission package control of the assets that belong to the mission package, including specific fire control and aviation asset guidance (such as the control station for an unmanned system), the communications equipment, and the computer processing to handle all the analysis and reporting needed; and
- A support services subsystem, which includes the distribution of power, water, fuel, and ammunition; specific maintenance and support tools; and the processing and equipment to allow monitoring of system health.

The choice of names for system elements have been left as unrestrictive as possible to allow as many existing weapon, aviation, and ISR&T systems as possible to be considered as potential solutions and avoid excluding options that do meet the required functionality. These system elements are the building blocks to allow assessment of potential solutions. However, as the major functionality of the system is contained within the ISR&T and shooter subsystems, that is the focus of the analysis of alternatives.



Figure 16 System Element Hierarchy

The most critical outcome of the functional allocation is the traceability of required functionality to the specific portion of the system under development that must provide that functionality. This trace is important in assuring that all of the required functionality is assigned to a system element (i.e., that required function will be implemented in the system) and also that each defined system element has been allocated at least one function (i.e., that all system elements are necessary). The trace between system functions and system elements has been captured in the system architecture and is documented in the LAMP combined Operational Activity to Systems Function Traceability Matrix (SV-5a) and Operational Activity to Systems Traceability Matrix (SV-5b), provided as Appendix C.

G. FUNCTIONAL REQUIREMENTS

Functional requirements were derived from the functional architecture developed for the LAMP. These requirements were then allocated to the specific system elements responsible for implementing this functionality. The purpose of the functional requirements is to capture the specific criteria that physical solutions for each of the subsystems must meet in order for the LAMP as a whole to meet its operational requirements and satisfy the capability gaps. Table 8 lists the functional requirements broken out by system element.

Table 8 LAMP Functional Requirements

Shipboard Weapon System	
Weapon	The Weapon shall have a range of 13 nautical miles.
Delivery System	The Delivery System shall have a minimum firing rate of 5 rounds per minute.
Air Detachment	
Air Platform	The Air Platform shall operate at least one Air Weapon System and at least one Air ISR System. The Air Platform shall have a range of at least 100 nautical miles.
Air Weapon System	The Air Weapon System shall have a firing rate of at least five rounds per minute.
Air ISR System	The Air ISR System shall locate targets with a target location error of 10 meters or less.
C2 Subsystem	
Fire Control	The Fire Control shall be capable of calculating solutions for Air Weapon Systems and Shipboard Weapon Systems. The Fire Control shall calculate firing solutions to support a firing rate of at least five rounds per minute.
Communications	The Communications Subsystem shall support voice and data links with at least three Air Platforms. The Communications Subsystem shall be capable of at least two voice and data links in addition to the Air Platform links.
Air Asset Control	The Air Asset Control shall be capable of controlling and guiding three Air Platforms simultaneously.
Data Processor	The Data Processor shall be capable of integrating data from three Air Platforms and one Shipboard Weapon Systems.
Support Subsystem	
Support Distribution System	The Support Distribution System shall provide power, water, cooling, fuel, ammunition, and networks to the LAMP subsystems.
Status Monitor	The Status Monitor shall simultaneously monitor the health and status of the LAMP C2 Subsystem, up to three Air Platforms and assorted weapons and ISR subsystems.
Maintenance System	The Maintenance System shall include all support tools for operational level preventive and corrective maintenance. The Maintenance System shall provide the maintenance actions and repairs to achieve a LAMP operational availability of 90%.

H. PHYSICAL SOLUTIONS

With the generic physical architecture established and functional requirements allocated to each of the generic system elements, the project considered the currently fielded systems that met the requirements allocated to each of those elements. The specific instantiation of a generic system element is referred to as an “asset” for the remainder of this report. Put another way: assets are selected to fill the role of a system element in order to define a specific solution; the combination of assets defines a particular LAMP configuration.

While functional analysis and allocation provided element-level functional requirements to use as part of asset consideration, the constraints of the LCS seaframe levy non-functional requirements on the system elements that also need to be considered. The interface control document for the LCS MPs gave the authors insight into which factors should be considered for the candidate system physical solutions. Specifically, the areas of interest for the LAMP were size and weight considerations. Clearly, there are a significant number of interface and integration issues to consider; however, it appeared that size and weight constraints would have the greatest influence over the physical architecture. Additionally, these two areas were given more consideration since the candidate systems that met the operational and functional requirements of the LAMP were similar to systems already fielded on the LCS. Given these similarities, interfaces such as power, heating, ventilation, air conditioning, damage control, and data were considered lower priority for the study.

Two LCS module types (weapons and aviation modules) and the weapons magazine were considered during the evaluation of physical solutions; all played an important role in determining suitable candidates for the LAMP physical architecture. For example, weight considerations alone eliminated the 155 mm Advanced Gun System from the LAMP. In much the same way (for both size and weight), the Marine Corps CH-53 helicopter could not be considered as a possible alternative for the LAMP system. Size and weight constraints as they apply to candidate solutions are discussed in the following sections.

1. Shipboard Weapon System

The shipboard weapon system must engage ground targets from the LCS platform. The candidates for the shipboard weapons system are a naval gun or existing Army missile system modified for shipboard use. Figure 17 shows the potential candidates for an instantiated physical shipboard weapon.

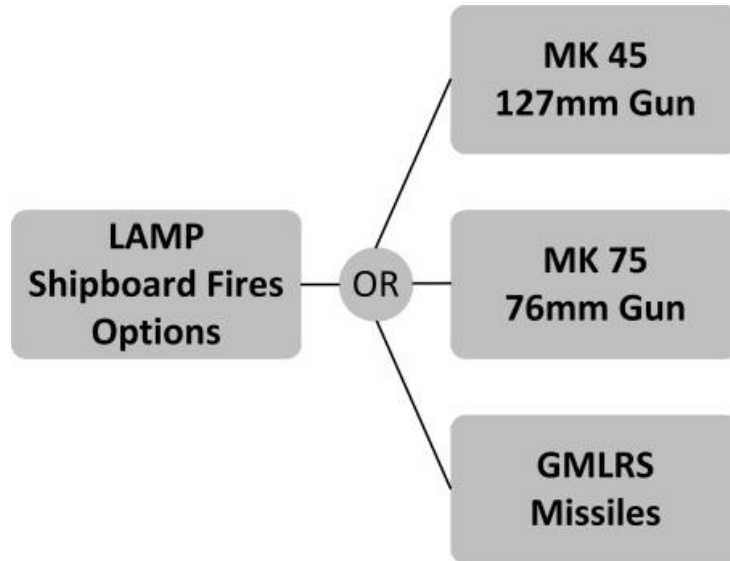

Figure 17 Potential Shipboard Weapons Systems

The selected systems are intended to consider the range of weapon systems available for the LCS platform. The two artillery systems contrast a high-caliber, lower firing rate system against a smaller caliber, higher firing rate system. The missile system introduces a system with higher single-engagement effectiveness yet lower total number of rounds. The following sections further describe the systems considered as potential shipboard weapon systems for the LAMP.

a. *MK 75 76 mm Gun*

The MK 75 gun is suitable for installation on small combatants, such as LCS, due to its light weight and low manpower requirements. One gun mount is installed aboard [United States Navy] frigates and larger USCG cutters. The MK 75 was provisionally approved for service use in September 1975. BAE Systems (The former Naval Systems Division of FMC Corporation) and General Electric Co. (Ordnance Systems Division)

were licensed by the gun's designer, OTO Melara of La Spezia, Italy, and competed for the right to manufacture the MK 75 in the United States. In 1975, BAE systems won the competition. Since 1981, all MK 75 buys have been competed between BAE systems and OTO Melara. The U.S. Navy is no longer acquiring MK 75 guns but has logistics support contracts with BAE systems and OTO Melara. The first MK 75 gun produced in the U.S. was delivered in August 1978. The MK 75 gun is in the sustainment phase of the product life cycle. System improvements include: barrel tube upgrade, breechblock positive stops, and barrel cooling panel upgrade. (U.S. Navy 2013)

Although not originally intended as a naval surface fires weapon, the MK 75 76 mm gun (Figure 18) has the potential to support amphibious forces with extended range projectiles. The 21 nautical mile (NM) range of these projectiles exceeds the 13 NM requirement of the Joint Fires ICD. The extended range projectiles were designed with naval fires support in mind. Additionally, the rapid-fire capability of the MK 75 gives it the ability to concentrate considerable amounts of ordnance on target. This capability makes the MK 75 a candidate for suppression and volume fires effects as well as being effective against hard and soft targets. At approximately 17,000 pounds, the weight of the MK 75 and its ammunition stores also appear to be within the weight limits of an LCS mission package.



Figure 18 OTO Melara MK 75 76 mm gun (U.S. Navy Photo)

b. MK 45 5/62

The MK 45 five inch gun (Figure 19) is deployed on both Arleigh Burke class destroyers and Ticonderoga class cruisers. Its main warfare function is NSFS, but it also supports the naval mission areas of surface warfare and air warfare. The MK 45 is ideally suited for the NSFS mission. The gun has the ability to support marine amphibious and expeditionary forces with conventional and extended range ammunition. This ubiquitous gun is one of the most widely used naval guns in the world. Its prevalence helps to make it easily supportable and logistically sustainable. “The MK 45 gun was developed as a lighter weight, more easily maintained replacement for the MK 42 5/54 caliber gun mount. The MK 45 Mod 4 gun mount upgrade includes a longer barrel (62 calibers) that improves the gun’s effectiveness as a land attack weapon (naval surface fire support)” (U.S. Navy 2013b). “The [MK 45] gun mount includes a 20 round automatic loader drum. The gun’s maximum firing rate is 16–20 rounds from the loader drum per minute. The rounds in the loader drum can be fired with one crewmember located at the EP-2 console below deck” (U.S. Navy 2013b). If more rounds are required than the loader can supply, then a full gun crew of six personnel is required.

Given the constraints of the LCS ICD, the weight of the MK 45 gun is too great for integration with a LCS weapon system module. The approximately 53,000-pound weight of the mount easily exceeds the maximum weight for the LCS weapon type module (Miller, Georgiadis, and Laun 2013). Therefore, the MK 45 was removed from the candidate solutions list.



Figure 19 MK 45 5/62 Lightweight Gun System (U.S. Navy Photo)

c. GMLRS

The Guided Multiple Launch Rocket System (GMLRS) is an upgrade to the M26 rocket, producing precise destructive and shaped fires against a variety of target sets. GMLRS provides close, medium, and long range precision and area fires to destroy, suppress and shape threat forces, and to protect friendly forces against: cannon, mortar, rocket and missile artillery, light material and armor, personnel, command and control, and air defense surface targets. GMLRS integrates guidance and control packages and an improved rocket motor, achieving greater range and precision accuracy than the M26, requiring fewer rockets to defeat targets and thereby reducing the logistics burden of the weapon system. The two fielded variants are the M30 GMLRS with dual-purpose improved conventional munitions (Increment 1) and the M31 GMLRS Unitary (Increment 2) with a 200-pound class high explosive warhead equipped with a dual-mode fuse (point detonating and delay). The new M31A1 will integrate multi-mode fuzing options (proximity, point detonate, and delay), expanding the Multiple Launch Rocket System (MLRS) target set into urban, complex, pre-planned and Troops in Contact scenarios, by delivering a low collateral damage, precision-strike rocket. (U.S. Army 2014a)

The M31 GMLRS launch platforms are either the M142 High Mobility Artillery Rocket System (HIMARS), shown in Figure 20, or the M270 MLRS. Six M31 missiles can be loaded per missile pod.

The GMLRS family of missiles utilizes inertial guidance that is updated with GPS. Given the selection of this candidate shipboard system, the LAMP will use a modified HIMARS launch platform for use on the LCS. For the purposes of analysis, the LAMP system was modeled using a M31 unitary missile for its capability against hardened targets.



Figure 20 GMLRS Rocket (U.S. Army photo)

At 18,500 pounds GMLRS is within the weight limit to be considered for the LAMP. As noted, the LAMP considered the HIMARS vice MLRS for the candidate solution. However, it is believed that using an actual HIMARS unit at sea was an excessive risk and that a better design solution would consider integrating the launcher-loader module (LLC) part of the HIMARS (Miller, Georgiadis, and Laun 2013). An integrated LLC concept would be similar to the depiction shown in Figure 21.

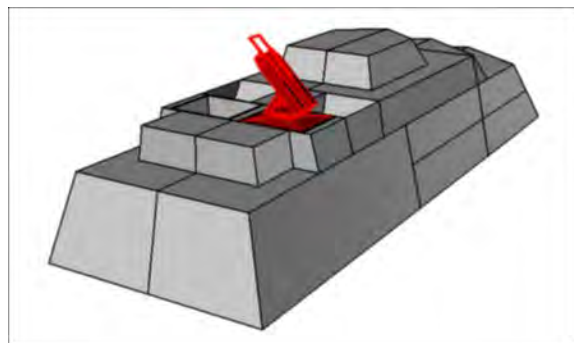

Figure 21 Integrated GLRMS (from Miller, Georgiadis; Laun 2013)

d. Relevant Characteristics

Table 9 summarizes the salient characteristics of the candidate shipboard weapons for the LAMP. The relevant shipboard weapon system parameters used for modeling of the LAMP are: range, probability of success, rate of fire, salvo size, magazine capacity, and projectile velocity. All of the parameters used in the modeling and simulation of the shipboard weapons systems are, themselves, weapon system characteristics that have been referenced from various locations -- with the exception of salvo size and probability of success. Salvo size is an assumed value that the authors believed were the minimum size necessary to achieve success. With the assumed value of salvo size, probability of success was then calculated using the total weight of explosives delivered on target.

Table 9 Relevant Shipboard Weapon System Characteristics (after Polmar 2005; Graham 2004; Pincoski 2008)

System	Range (NM)	Probability of Success	Rate of Fire (per min)	Salvo Size	Magazine Capacity	Projectile Velocity (m/s)
76 mm Gun	21	0.10-0.58	80	8	800	914.4
GMLRS (M31)	37	0.79-0.91	12	1	12	850.7

2. Air Detachment

a. Air Platform

There were, initially, four helicopters that, in conjunction with their weapon systems, could ostensibly address the functional requirements allocated to the LAMP air platform. In addition to being assessed for functional and technical suitability, each was assessed for non-functional requirements as well as Doctrine, Organization, Training, Materiel, Leadership & Education, Personnel, and Facilities considerations.

The U.S. Army AH-64 attack helicopter was one of the five helicopters originally considered for the project. However, the authors felt that issues of doctrine, organization,

training, and logistics were prohibitive factors in including the aircraft in the analysis. Given that, the helicopters chosen for inclusion as candidates for the LAMP air platform element were the MQ-8B Fire Scout, MH-60R Seahawk, and AH-1Z Viper.

(1) AH-1Z Viper

“The AH-1Z attack helicopter provides rotary wing close air support, anti-armor, armed escort, armed/visual reconnaissance and fire support coordination capabilities under day/night and adverse weather conditions for the USMC. The AH-1Z is equipped with an integrated advanced fire control system and the capacity to support multiple weapons configurations” (U.S. Navy 2014a).

The AH-1Z (Figure 22) adds additional capability for the close air support mission of the amphibious task force. With its ability to carry a mix of both Hellfire and 70mm rockets, including an AH-1Z as a LAMP air asset adds significant additional firepower to the MEU’s standard compliment of four AH-1Z platforms. Given that, it is clear that by deploying an AH-1Z with the LAMP, the MEU air combat element increases its attack helicopter capability by twenty-five percent. Further, the use of the AH-1Z has the potential to minimize logistics demand on the LAMP and LCS by leveraging maintenance support from the embarked MEU air wing.



Figure 22 AH-1Z Viper Attack Helicopter (U.S. Navy Photo)

(2) MH-60R Seahawk

“The MH-60R Seahawk missions are ASW, Anti-Surface Warfare, Surveillance, Communications Relay, Combat Search and Rescue, Naval Gunfire Support and logistics support. [ASW] and [SUW] are the MH-60R’s primary missions. Secondary missions include Search and Rescue, Vertical Replenishment, [NSFS], logistics support, personnel transport, Medical Evacuation, and Very High Frequency/Ultra High Frequency/Link Communication Relay” (U.S. Navy 2014b). The MH-60R (Figure 23) is also equipped with the AN/APS-153 radar. This multifunction Synthetic Aperture and Inverse Synthetic Aperture Radar is ideally suited for the LAMP ISR functionality. The radar can detect, image, identify, and track targets at a safe standoff distance for the aircrew. The MH-60R also has an EO/IR targeting system that gives the helicopter the capability to execute engagements with both the Hellfire missiles and Advanced Precision Kill Weapon System (APKWS) rockets. ISR systems and missiles are addressed in more detail in Section C.



Figure 23 MH-60R Seahawk Helicopter (U.S. Navy Photo)

(3) MQ-8B

According to the U.S. Navy, “the Fire Scout [VTUAV] system is comprised of up to three MQ-8B Fire Scout air vehicles, ground control stations, and associated control handling and support equipment. With vehicle endurance greater than eight hours, a VTUAV system will be capable of twelve continuous hours of operations providing

coverage 110 nautical miles from the launch site,” (U.S. Navy 2014c). The MQ-8B (Figure 24) includes persistent long-range radar surveillance, EO/IR targeting, and APKWS missiles with the platform. The MQ-8B is well suited to add ISR capability to the LAMP with its AN/ZPY-4 radar and its BriteStar II EO/IR system.



Figure 24 MQ-8B Fire Scout (U.S. Navy Photo)

(4) Relevant Characteristics

In order to adequately characterize the air platforms’ contribution to the LAMP ability to perform fire support, the maximum available missile carrying capacity of each air platform was essential to meeting overall mission success parameters. The initial approach considered maximizing firepower and lethality of both aviation assets and shipboard weapons for the mission package. Additionally, since all of the helicopters are Navy aircraft, supportability and maintainability are greatly enhanced. Table 10 summarizes the salient characteristics of the candidate helicopters for the LAMP.

Table 10 Relevant Air Platform Characteristics (after U.S. Navy 2014a, Sikorsky 2014, and U.S. Navy 2014c)

Aircraft	Air-to-Ground Missile Types	Maximum APKWS Loadout	Maximum Hellfire Loadout	Maximum Cruise Speed (nm/hr)	Ceiling (ft)	Range (NM)
AH-1Z Viper	Hellfire / APKWS	76	16	142	10000	125
MH-60R Seahawk	Hellfire / APKWS	38	8	144	9945	123
MQ-8B Fire Scout	APKWS	6	0	80	12500	110

b. Air Weapon System

(1) Hellfire

“Hellfire is an air-to-ground, laser guided, subsonic missile with significant antitank capacity. It can also be used as an air-to-air weapon against helicopters or slow-moving fixed-wing aircraft. [...] The AGM-114 provides precision striking power against tanks, structures, bunkers and helicopters. The Hellfire missile is capable of defeating any known tank in the world today. It can be guided to the target either from inside the aircraft or by lasers outside the aircraft” (U.S. Navy 2009). The Hellfire is qualified for use on several helicopters in the U.S. inventory including the MH-60R and the AH-1Z, and has been demonstrated but not fielded on the MQ-8B (U.S. Navy 2009).

(2) APKWS

APKWS is a laser-guided rocket based on the Hydra 70 family of 2.75-inch rockets (U.S. Navy 2012). The APKWS is produced by adding a kit that turns the unguided rocket into an extremely accurate and effective missile (U.S. Navy 2012). Because it is an add-on kit, the APKWS is cost effective and easily integrated into the large inventory of aircraft already qualified to use hydra 70 rockets (U.S. Navy 2012). The APKWS is qualified on all of the aircraft under consideration for the LAMP including the unmanned MQ-8B (U.S. Navy 2012). The missile’s probability of success, along with the Hellfire’s, is shown in Table 11.

Table 11 Relevant Missile Characteristics (after Jacobson 2010)

Missile	Range (NM)	Rate of Fire (rounds per minute)	Probability of Success
Hellfire	4.3	8-18	0.63-0.72
APKWS	2.7	8-20	0.47-0.56

Even with the candidate helicopters already under consideration, the air-to-ground missile selection was, as previously noted, somewhat of a bottom-up evolution. Since fires were a prime consideration for the LAMP, missile selection was extremely important. According to the Naval Aviation Vision 2010 (U.S. Navy 2009) the available missiles for the candidate helicopters noted above are the Hellfire, APKWS, and Low-Cost Guided Imaging Rocket (LOGIR). Given the similar performance characteristics of the LOGIR and APKWS missiles, the LOGIR is not considered in this report. Since both missiles use the identical base rocket system (Hydra 70) their effective range, accuracy, and firepower are considered similar enough that, for the purposes of the LAMP evaluation, only one of the two missiles was necessary for evaluation. APKWS was chosen due to its being qualified for use on the AH-1Z and its planned qualification on the MH-60R.

With potential candidates for the aviation fires support selected, a potential set of architectures for modeling would resemble that shown in Figure 25. The feasible LAMP configurations, discussed in the following chapter, address the various combinations of the three helicopters feasible for deployment as an overall LAMP air detachment.

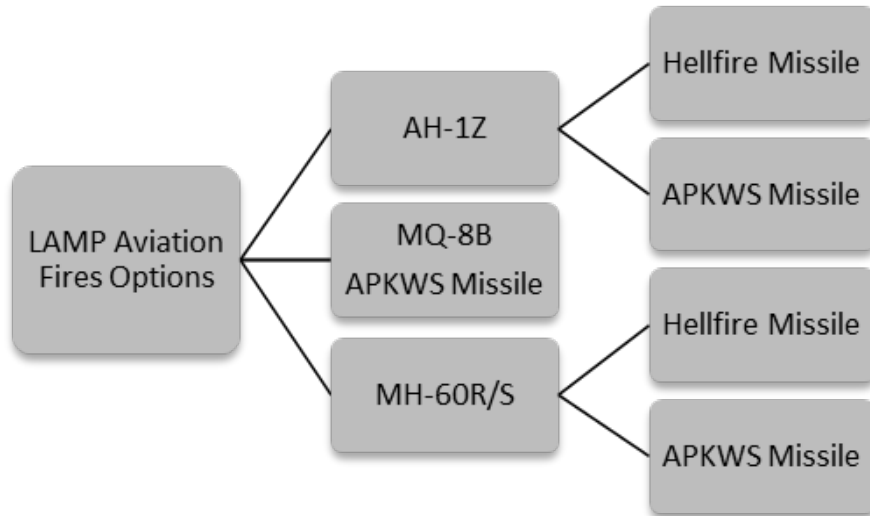

Figure 25 Potential Air-to-Ground Systems

c. Air ISR&T System

The two classes of systems that are critical with respect to the LAMP aviation assets for the air ISR&T systems are the targeting designation systems and the search radars. All of the helicopters chosen had EO/IR/Targeting Systems and two of the three (AH-1Z and MQ-8B) have surface search radars.

It is important to note that shipboard sensor systems were not considered by this analysis due to the projected distance of the LCS platform to the AOR (20 nautical miles) and the assumed inability of shipboard sensor systems to detect threats over the horizon.

(1) AN/AAS-44C(V)1 EO/IR/Targeting System

The AN/AAS-44C(V)1 is a forward looking infrared (FLIR) system installed on the MH-60R helicopter. In addition to FLIR, the AN/AAS-44C(V)1 also provides long-range detection of targets in the visible spectrum with its electro-optic sensor capability. The AN/AAS-44C(V)1 also includes laser designation and illumination, and range detecting capabilities allowing the MH-60 to detect, track, and engage hostile targets. “It features multiple fields of view, electronic zoom and multimode video tracking and was designed to incorporate future growth options and performance enhancements” (Raytheon 2014a). The AN/AAS-44C(V)1’s laser designation, range finding and targeting capabilities support both the Hellfire and APKWS missiles.

In analyzing the LAMP, one of the modeling and simulation input parameters used for determining the systems ISR effectiveness was radius of sensor detection range. Since actual EO/IR system detection ranges are classified, the authors chose to use the range given for a similar FLIR system, the AN/ASQ-228 Advanced Targeting FLIR, to model detection range for the AN/AAS-44C(V)1. The authors believe that the advertised 40 NM range for the AN/ASQ-228 is a reasonable estimate for the purposes of modeling the LAMP system while keeping the study unclassified. A close-up of the AN/AAS-44C(V)1 is shown in Figure 26.



Figure 26 AN/AAS-44C(V) (U.S. Navy Photo)

(2) AN/APS-153 Radar

The AN/APS-153(V) provides the MH-60R and its host ship littoral and maritime domain awareness. Radar operators can classify detected moving ship targets under night and restricted visibility using the high-resolution Inverse Synthetic Aperture Radar (ISAR) mode. This mode allows the MH-60R to operate outside of visual and lethal range of a potential enemy and to identify detected targets when images are combined with other intelligence. The MH-60R, combined with the AN/APS-153(V), is designed to operate from helo-capable small combatants to the largest aircraft carriers as a key element in the helicopter-ship system. Via the aircraft's C-band data link, shipboard personnel have virtually the same radar picture as the flight crew. The radar will withstand the harshest maritime and helo vibration environments. (Telephonics n.d.a, 1-2)

Some of the modes of operation are ISAR imaging, synthetic aperture radar (SAR) imaging, navigation, and small target detection. SAR imaging can aid in target identification. The photograph in Figure 27 is a SAR image of hangars at Kirtland air force base with a one-meter resolution.

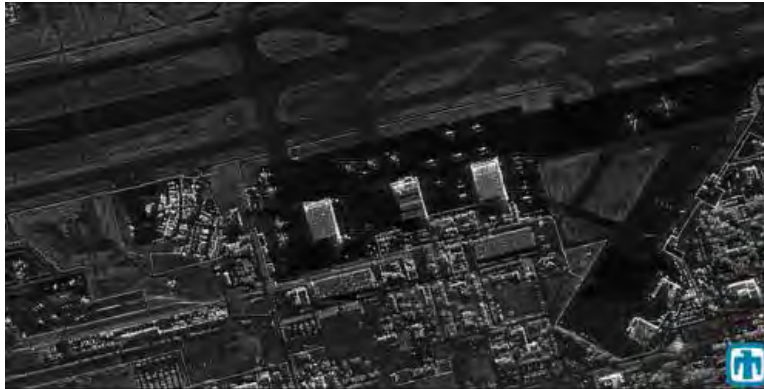

Figure 27 SAR Image (from Sandia National Laboratory)

(3) AN/AAQ-30 TSS EO/IR/Targeting System

[Target Sight System (TSS)] is the multi-sensor [EO/IR] fire control system (AN/AAQ-30) for the U.S. Marine Corps AH-1Z Viper attack helicopter. It is a large-aperture midwave [FLIR] sensor, color TV, laser designator/rangefinder (with eyesafe mode), and on-gimbal inertial measurement unit integrated into a highly stabilized turret. The turret mounts to the nose of the aircraft via the Lockheed Martin-developed aircraft interface structure. TSS provides the capability to identify and laser-designate targets at maximum weapon range, significantly enhancing platform survivability and lethality. (Lockheed Martin 2014)

For the same reasons as the AN/AAS-44C(V)1 mentioned above, the authors believe that the 40 NM range (Lockheed Martin 2014) is a reasonable estimate for the purposes of modeling the LAMP system while keeping the study unclassified. The TSS laser targeting capabilities are compatible with both the Hellfire and APKWS missiles. A close up of the TSS is shown in Figure 28.



Figure 28 AN/AAQ-30 (U.S. Navy Photo)

(4) AN/ZPY-4(V)1 Radar

The AN/ZPY-4(V)1 (Telephonics model RDR-1700B, hardware shown in Figure 29) is a long range surface search and surveillance radar that can track up to 200 targets and can also image tracks when in either the SAR or ISAR modes. The RDR-1700B provides three modes for target imaging, including ISAR, strip-map, and spotlight SAR, which provide high-resolution images of targets or terrain (Telephonics n.d.b). The radar is also a weather avoidance radar. The RDR-1700B can detect targets down to one square meter with a maximum radar range of 120 NM.

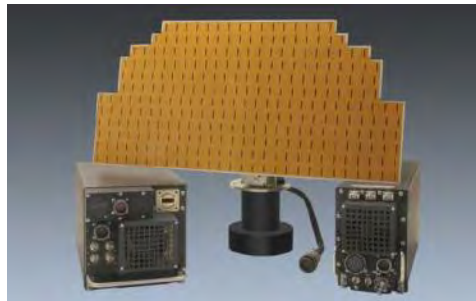

Figure 29 AN/ZPY-4(V)1 Radar (from Telephonics n.d.b)

(5) AN/AAQ-22E EO/IR and Laser Designator

FLIR Systems Incorporated builds the AN/AAQ-22E EO/IR and Laser Designator system. The unit has the same functionality as the AAS-44C and the TSS, in that all three are long-range targeting and designation systems. FLIR Systems uses the AN/AAQ-22E as the BRITE Star II. The unit is fielded on the MQ-8B, the U.S. Marine

Corps UH-1, the Bradley fighting vehicle, and Norwegian Navy patrol boats (FLIR Systems, Inc. n.d., 1). The AN/AAQ-22E’s high-resolution thermal imagery, laser range finder, and laser designator capabilities are well suited for the proposed LAMP mission. As with the AAS-44C and the TSS, it is compatible with Hellfire and APKWS. A close up of the AN/AAQ-22E is shown in Figure 30.



Figure 30 AN/AAQ-22E (U.S. Navy Photo)

Table 12 summarizes the relevant characteristics of the various LAMP air assets with respect to ISR&T data collection.

Table 12 Relevant Air ISR&T Asset Characteristics (after Raytheon 2014b)

Aircraft	Detection Range (NM)
AH-1Z Viper	40
MH-60R Seahawk	123
MQ-8B Fire Scout	137.5

d. Overall LAMP Configuration

With the potential LAMP shipboard weapon systems and air assets identified, the analysis focused on defining those LAMP configurations that conform to the MP requirements identified in the LCS MP interface control document. LAMP (and individual asset) characteristics such as weight, size, and quantity were used to define the following LAMP characteristics:

- Quantity of shipboard weapon system ammunition
- Feasible air detachment configurations
- Quantity of missiles available for air asset reload

The quantity of ammunition available for the MK 75 76 mm gun was estimated based on an assumption that two weapon system modules of the LAMP are reserved as a magazine for the necessary ammunition. The 7,500 kilogram weight limit of each weapon system module, as documented in the LCS MP interface control document, contributes to an estimate of 800 rounds of ammunition available for MK 75 engagements. The quantity of rounds available to the GMLRS asset is estimated at 12 (Miller, Georgiadis and Laun 2013).

Feasible LAMP air detachment configurations have been assumed to include only those air detachments that are made up of the same type of air platform, due to a desire to minimize the logistics tail associated with a given LAMP configuration. Further, and for the same reason, feasible LAMP air detachment configurations are assumed to only include those air detachments that utilize a single missile type.

It is important to note that the LCS MP interface control document states that the LCS supports only a single manned air asset (i.e., only a single MH-60R or AH-1Z), but up to three unmanned air assets (i.e., MQ-8Bs). This requirement further limits the feasible LAMP air detachment configurations to those detachments with only a single manned air asset. However, during Rim of the Pacific Exercise 2014 the USS Independence (LCS 2) supported the use of two MH-60S helicopters, suggesting the potential for operations of two manned aviation assets aboard the LCS platform (Jones 2014). As a result, this project addresses LAMP air detachments that include up to two MH-60R or two AH-1Z air assets; final recommendations of the project, presented in Chapter V, further describe this discrepancy.

The quantity of missiles available for reloading potential air assets was, similarly, based on data from the LCS MP interface control document as well as size and weight estimates of the Hellfire and APKWS missiles. LCS MP interface control document data was used to estimate that the LCS magazine supports up to 77 Hellfire missiles, all of which would be available to LAMP air detachment. Physical size and weight

characteristics of the Hellfire and APKWS were used to estimate that three APKWS missiles take up the weight of a single Hellfire, while the volume of an APKWS missile is less than a quarter of the volume of a Hellfire missile. As a result, the LCS magazine is (conservatively) assumed to support 231 APKWS missiles; again, all of these missiles are assumed to be available to a given LAMP air detachment.

THIS PAGE INTENTIONALLY LEFT BLANK

IV. MODELING AND EVALUATION

In order to evaluate the various LAMP configurations identified through functional analysis and allocation, the project developed back of the envelope (BOE) and discrete-event models to assess each configuration's ability to meet the MOEs defined by the LAMP DRM. In addition, the project estimated the life-cycle cost of each LAMP configuration in support of identifying the most cost-effective LAMP for employing fires and performing ISR&T data collection in support of amphibious operations. This chapter presents the models developed by the project as well as the cost breakdown structure and cost data used to develop life-cycle cost estimates (LCCEs) of the LAMP configurations. The following chapter synthesizes the resultant data in an analysis of alternatives.

A. MODEL FACTORS AND EXPERIMENTAL DESIGN

There are many factors that influence the effectiveness of an attacking formation against its target. Elements such as weather conditions and parameters of the defending force are not under our control in real-life situations. However, other battle parameters, such as weapon system capabilities and the make-up of deployed formations, are under our control for future deployments. These factors can be varied in a model of a battle to determine the effect the changes have on the deployed formation's effectiveness.

In order to compare the various LAMP alternatives equivalently, it was necessary to define each MP by a common set of variables (to compare "apples to apples"). The factors used to describe the various LAMP configurations were derived from the LAMP physical architecture; Table 13 defines the basic factors and factor levels used to describe the various LAMP configurations.

Table 13 LAMP Alternative Factor Levels

Factor Level	Helo1	Helo2	Helo3	Shipboard Weapon System
0	None	None	None	None
1	MQ-8B w/ APKWS	MQ-8B w/ APKWS	MQ-8B w/ APKWS	76mm Gun
2	MH-60R w/ Hellfire	MH-60R w/ Hellfire	-	GMLRS
3	MH-60R w/ APKWS	MH-60R w/ APKWS	-	
4	AH-1Z w/Hellfire	AH-1Z w/Hellfire	-	-
5	AH-1Z w/APKWS	AH-1Z w/APKWS	-	-

As discussed in Chapter III, however, not all permutations of the factors captured in Table 13 represent feasible configurations for deployment aboard the LCS seaframe. In short, the feasible air detachment configurations include those configurations with only a single asset type. For example, a given LAMP configuration may only include MH-60R air assets equipped with a single missile type in order to decrease the logistics tail associated with the air detachment. As a result, the air detachment configurations evaluated in this report are limited to those presented in Table 14.

Table 14 Evaluated LAMP Air Detachment Configurations

AirDetachment	Helo1	Helo2	Helo3
0	None	None	None
1	MQ-8B	None	None
2	MH-60R w/Hellfire	None	None
3	MH-60R w/APKWS	None	None
4	AH-1Z w/Hellfire	None	None
5	AH-1Z w/APKWS	None	None
6	MQ-8B w/APKWS	MQ-8B w/APKWS	None
7	MH-60R w/Hellfire	MH-60R w/Hellfire	None
8	MH-60R w/APKWS	MH-60R w/APKWS	None
9	AH-1Z w/Hellfire	AH-1Z w/Hellfire	None
10	AH-1Z w/APKWS	AH-1Z w/APKWS	None
11	MQ-8B w/APKWS	MQ-8B w/APKWS	MQ-8B w/APKWS

Finally, the identified LAMP air detachment configurations and potential shipboard weapon systems were used to define the LAMP configurations evaluated for mission effectiveness. The 36 evaluated LAMP configurations are provided in Table 15.

Table 15 Evaluated LAMP Configurations

LAMP Configuration	Air Detachment	Shipboard Weapon System
0	None	None
1	None	76 mm Gun
2	None	GMLRS
3	(1) MQ-8B w/APKWS	None
4	(1) MQ-8B w/APKWS	76 mm Gun
5	(1) MQ-8B w/APKWS	GMLRS
6	(1) MH-60 w/Hellfire	None
7	(1) MH-60 w/Hellfire	76 mm Gun
8	(1) MH-60 w/Hellfire	GMLRS
9	(1) MH-60 w/APKWS	None
10	(1) MH-60 w/APKWS	76 mm Gun
11	(1) MH-60 w/APKWS	GMLRS
12	(1) AH-1Z w/Hellfire	None
13	(1) AH-1Z w/Hellfire	76 mm Gun
14	(1) AH-1Z w/Hellfire	GMLRS
15	(1) AH-1Z w/APKWS	None
16	(1) AH-1Z w/APKWS	76 mm Gun
17	(1) AH-1Z w/APKWS	GMLRS
18	(2) MQ-8B w/APKWS	None
19	(2) MQ-8B w/APKWS	76 mm Gun
20	(2) MQ-8B w/APKWS	GMLRS
21	(2) MH-60 w/Hellfire	None
22	(2) MH-60 w/Hellfire	76 mm Gun
23	(2) MH-60 w/Hellfire	GMLRS
24	(2) MH-60 w/APKWS	None
25	(2) MH-60 w/APKWS	76 mm Gun
26	(2) MH-60 w/APKWS	GMLRS
27	(2) AH-1Z w/Hellfire	None
28	(2) AH-1Z w/Hellfire	76 mm Gun
29	(2) AH-1Z w/Hellfire	GMLRS
30	(2) AH-1Z w/APKWS	None
31	(2) AH-1Z w/APKWS	76 mm Gun
32	(2) AH-1Z w/APKWS	GMLRS
33	(3) MQ-8B w/APKWS	None
34	(3) MQ-8B w/APKWS	76 mm Gun
35	(3) MQ-8B w/APKWS	GMLRS

B. MODEL ARCHITECTURE AND LOGIC

In order to evaluate the effectiveness of each possible LAMP configuration, models were created to represent the OPSIT described by the LAMP DRM. The first aspect of the OPSIT deals with the battlefield recognition and identification of enemy forces. The second aspect of the OPSIT deals with the engagement of targets and the effectiveness of a given configuration against an enemy force. Complete evaluation of potential solutions required modeling and simulation of both aspects of the OPSIT.

The model developed for this project does not consider elements such as weather conditions, the ability of the enemy to return fire, nor, in turn, the survivability of the given friendly force assets. The model focuses on providing a means to gauge the best combination of assets in a MP in terms of how effective those combinations are against a prescribed enemy force. The model addresses the specific MOEs defined as part of the DRM.

Two separate models were constructed to analyze the OPSIT described in the DRM—one to consider the ability of a LAMP configuration at collecting ISR&T data, and one to evaluate the effectiveness of a configuration at providing fire support. Both situations were considered through a BOE method (using Microsoft Excel) for quick, rough analyses as well as a discrete-event model (using ExtendSim) to more fully evaluate the effectiveness of alternative LAMP configurations. Screenshots of the discrete-event models are provided in Appendix D.

1. ISR&T Model

The ISR&T model assumes an initial threat density within the AOR. The threat density is calculated from the initial number of threats occupying the AOR (5,000 threats) and the square mileage of the AOR (10,000 square nautical miles), as defined by the DRM. With initial AOR conditions established, the BOE model relies upon the assumption that air assets travel at a constant speed during ISR&T operations with a circular area of ISR&T coverage. As the asset travels over the AOR, the coverage area associated with the air asset increases the percent of the AOR covered by the air asset's sensor over the course of the mission. With a defined probability of detection, the model

considers the ability of the air asset to detect threats throughout the AOR over time (i.e., as the coverage area of the air asset moves throughout the AOR).

The ISR&T BOE model calculates the percentage of threats detected over time in order to understand the distribution of this output over time. Figure 31 provides the general distribution of the percentage of threats detected over time for a single air asset, depicting a higher rate of detection early in the mission (due to the higher threat density existing within the AOR) and an asymptotic approach of the total number of threats. The rate of threat detection decreases due to the decrease in the number of threats and the associated decrease in the threat density within the AOR; the time between detections increases as the number of threats within a defined area decreases.

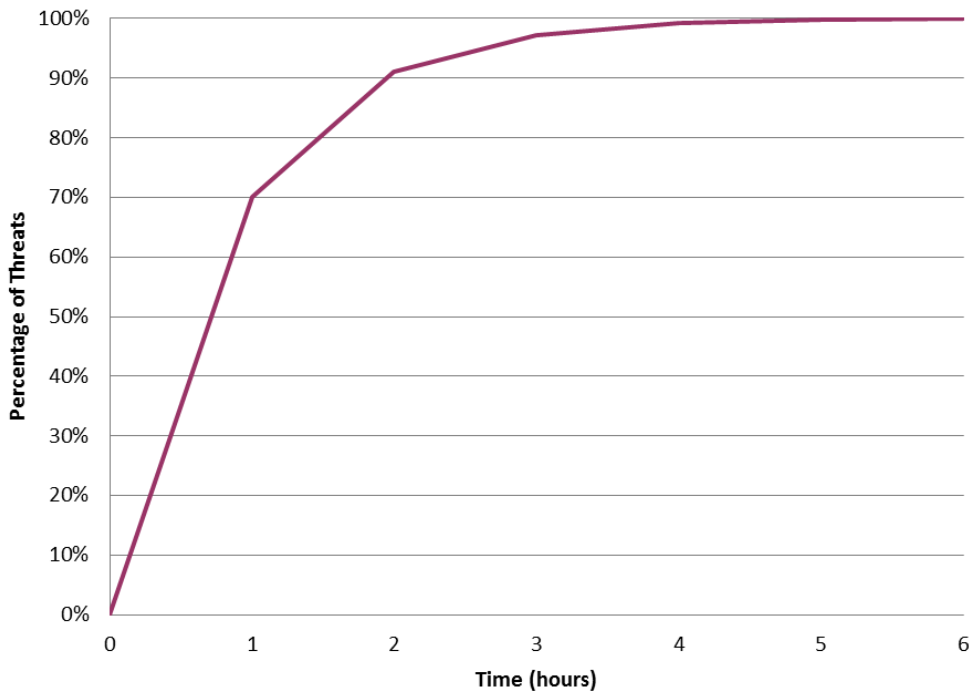

Figure 31 BOE Estimation of Percentage of Threats Detected over Time for Representative LAMP Configuration

The ISR&T discrete-event model builds on the logic established in the BOE model. The ISR&T discrete-event model creates a pool of initial threats based on the initial conditions used in the BOE model and described in the DRM. The discrete-event model then considers the coverage of up to three air assets (depending on the evaluated LAMP configuration) in support of identifying those targets during the mission. The logic associated with the ISR&T discrete-event model is depicted in Figure 32 and further explained in Table 16.

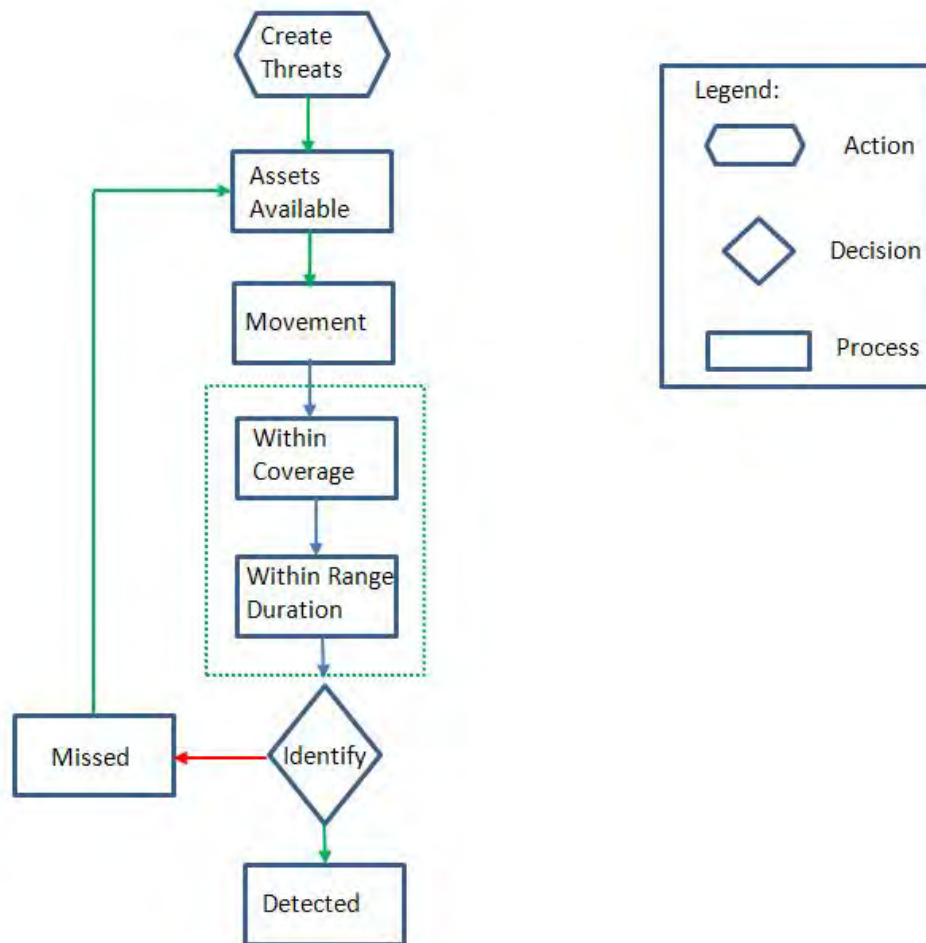

Figure 32 ISR&T Discrete-Event Model Block Diagram

Table 16 ISR&T Discrete-Event Model Functional Description

Step	Step Name	Description
1	Create Threats	This function creates the items that represent each individual target
2	Assets Available	This action selects amongst available assets and assigns an area of operations. This action mimics the C2 component of the model
3	Movement	Assets travel from the LCS to the area of operations and perform a scan of the area involving steps 3a and 3b.
3a	Within Coverage	Assets have a radius of detection based on operational altitude.
3b	Within Range	The endurance of the asset is based on its flight range
4	Identify	The targets are identified based on a probability of detection

The ISR&T discrete-event model, based on the mission and asset parameters discussed, provides effectiveness data for a given LAMP configuration in terms of the percentage of targets identified during a four-hour mission. Chapter V discusses the effectiveness of specific LAMP configurations in terms of the percentage of targets detected during an ISR&T data collection mission.

2. Shooter Model

Whereas the ISR&T model relies upon an initial number of threats, the shooter model is based upon the receipt of fire missions over time. This report assumes that the LAMP receives fire missions at a rate of one mission every fifteen minutes as a Poisson distribution, and that the overall fire support mission lasts for a duration of four hours.

The BOE shooter model considered two parameters of a given weapon system, including the rate of fire and the probability of successfully affecting a given target. These parameters were used to evaluate the percentage of targets successfully affected by the weapon system. Figure 33 depicts the generic output of the BOE model in terms of the percentage of targets successfully affected by a representative weapon system. As shown, the percentage of targets successfully affected by a weapon system, in terms of the fire missions received, eventually normalizes around a steady-state value. This steady-state value is ultimately defined by the rate of fire missions received by the

system, the rate of fire of the system, and the probability of successfully affected a target with single engagement.

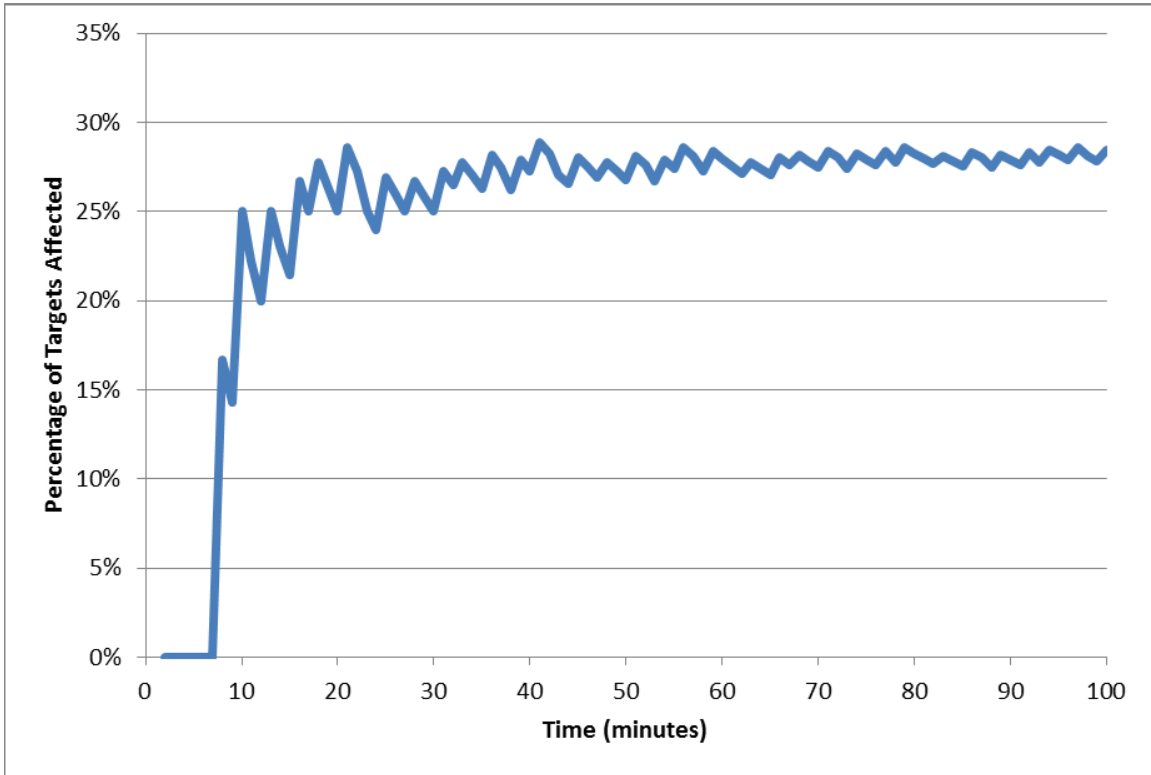

Figure 33 BOE Estimation of Percentage of Successful Fire Missions Associated with a Representative LAMP Configuration

The discrete-event shooter model adds additional complexity to the BOE model by considering the effects of utilizing the air assets as additional engagement platforms. Whereas the discrete-event model relies upon the logic of the BOE model to represent shipboard weapon systems, the air asset engagement sequence was modeled to account for the movement of a given air asset throughout the AOR and other characteristics unique to air asset engagement. Figure 34 depicts the logic associated with the discrete-event shooter model, with further explanation of the figure provided in Table 17.

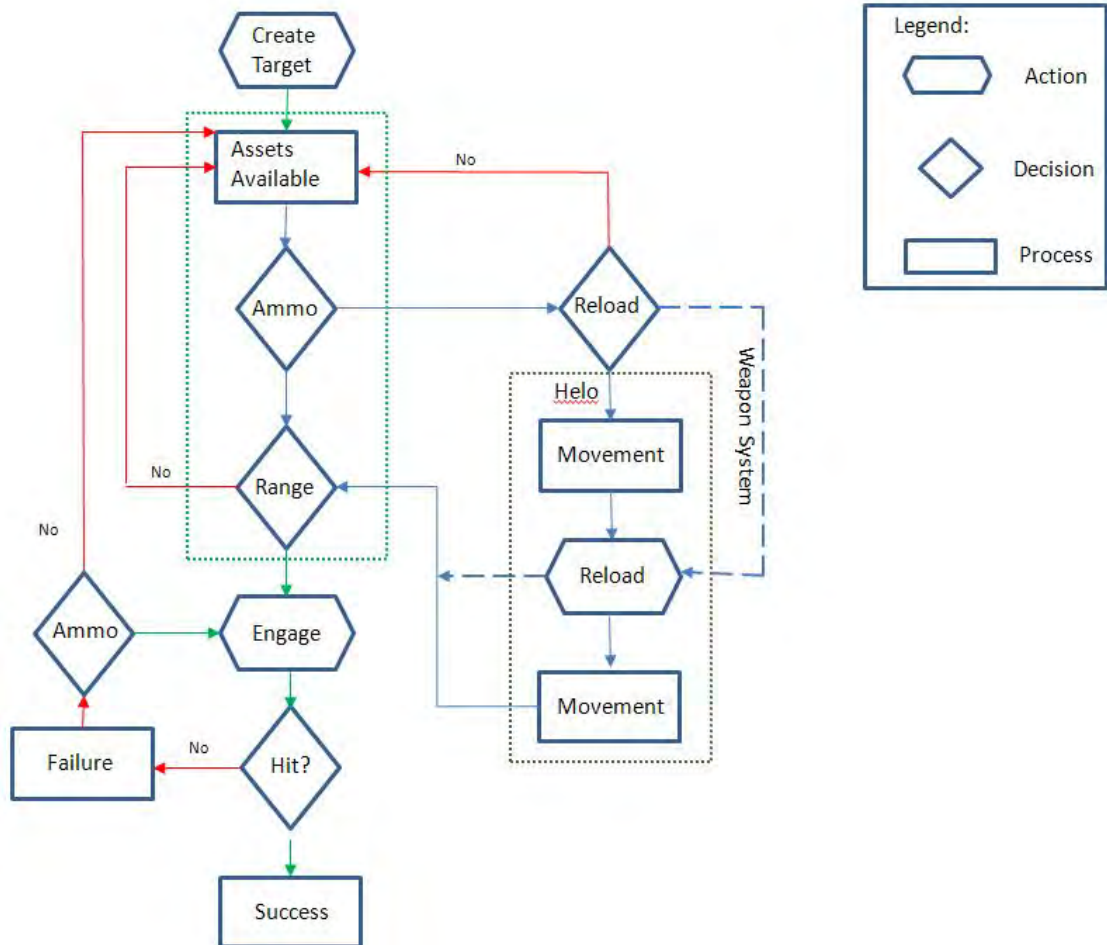

Figure 34 Shooter Discrete-Event Model Block Diagram

Table 17 ExtendSim Shooter Model Functional Description

Step	Step Name	Description
1	Create Threats	This function creates the items that represent each individual target
2	Assets Selection	This action selects amongst available assets based on ammunition and range. This section of the model acts as the C2 component of the model
2a	Ammo	Ammunition on hand is checked
2b	Range	The target must be within the range of engagement, if not then the target is passed to another asset
3	Reload	A time delay is entered here to account for loading of ammunition and refueling time for air assets.
4	Movement	Air assets only, this is the time it takes the air asset to travel to and from the LCS in order to reload ammunition
5	Engage	Action of shooting the target and the ballistic time it takes to hit the target
6	Hit	Probability of the round of hitting the target. This accounts for both the weapon accuracy and the probability of kill of the ammunition.

C. CONFIGURATION EFFECTIVENESS

The three dependent variables (responses) measured through simulation were percentage of targets detected, average engagement time, and percentage of targets successfully affected (i.e., the three MOEs first presented in Chapter II). The independent variables manipulated by this project were the shipboard weapon system (“Shipboard Weapon”) and the LAMP air detachment configuration (“Air Detachment”). The combination of a single Shipboard Weapon and a single Air Detachment defined a single LAMP configuration. Constraints and limitations of a LCS MP, as discussed in Chapters III and IV, result in a possible 36 LAMP configurations.

It is important to restate a LCS limitation first presented in Chapter III: per the LCS MP interface control document, the LCS air detachment is limited to not more than a single manned air asset. As a result, LAMP configurations 21 through 32 are not considered feasible alternatives. However, the LCS has operated with two manned air assets during recent naval exercises such as “Rim of the Pacific 2014” (Jones 2014). As a result, this report considers the effectiveness of these LAMP configurations. The

remainder of this chapter distinguishes between “feasible” and “infeasible” LAMP air detachment configurations; feasible configurations are considered for ultimate recommendations of this project; infeasible configurations are discussed for consideration in future work.

In order to identify statistically significant differences between the mean MOE values of each evaluated LAMP configuration, the models of each configuration were subjected to 500 simulation runs. The resultant simulation data was analyzed to identify the interval of the mean MOE value for each configuration (for each MOE) with a 95% confidence level. These confidence levels were then evaluated using Tukey’s honest significant difference (HSD) multiple comparison tests in order to identify those configurations with statistically different mean MOE values. These results were then used to identify the most effective configurations for each of the three MOEs. The following sections further describe the results of each MOE analysis.

1. Percent Detected

The data associated with the 500 samples for each LAMP configuration were used to calculate a confidence interval for each configuration’s ability to detect threats (as a percentage of total threats). As discussed in the physical solutions section of Chapter III, the shipboard weapon has no impact on the percentage of threats detected by a given LAMP configuration. As a result, Figure 35 depicts the percentage of threats detected for each air detachment with no distinction of the associated shipboard weapon; the shipboard weapon associated with a given air detachment does not impact the LAMP’s effectiveness in terms of MOE 1.

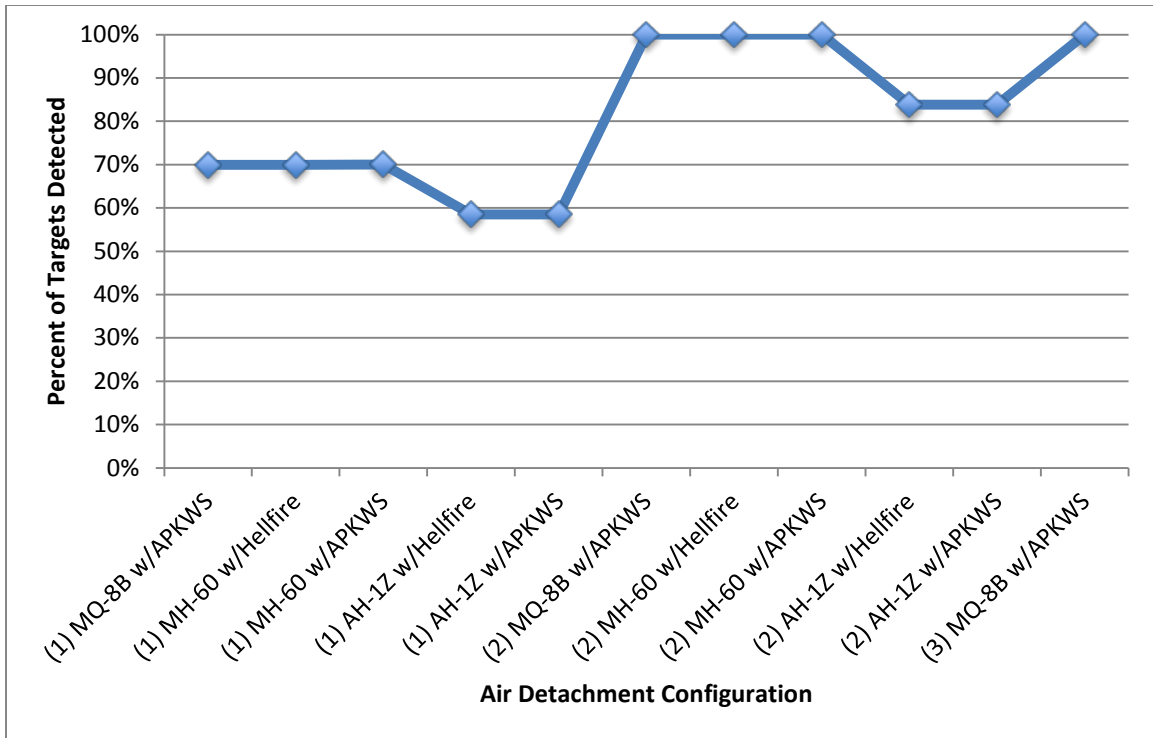

Figure 35 Percent Detected vs. Air Detachment Configuration

The mean percent detected of each configuration was assigned a 95% confidence interval in order to identify those configurations with statistically significant differences in percentage of threats detected. As discussed above, this analysis was performed using Tukey’s HSD multiple comparison tests.

The results of the means analysis and multiple comparison test indicate that, of the feasible air detachment configurations, a LAMP air detachment of two or three MQ-8Bs would be the most effective at detecting threats (with an average percentage of threats detected of 100%). The second most effective feasible configurations consist of either a single MQ-8B or a single MH-60R at 70% of threats successfully detected. The AH-1Z provides the least effectiveness in detecting threats with a mean value of 59%.

The ability to deploy two manned air platforms as a LAMP air detachment would not have a statistically significant impact on the percentage of threats detected; two MH-60R platforms provide the same effectiveness as two MQ-8B platforms (100% of threats detected).

2. Engagement Time

The data associated with the 500 samples for each LAMP configuration were also used to calculate a confidence interval for each configuration's average engagement time. Figure 36 depicts the engagement time (in minutes) for each shipboard weapon system and air detachment configuration. Each line on the graph represents a potential shipboard weapon, while potential air detachment configurations are captured along the x-axis of the graph.

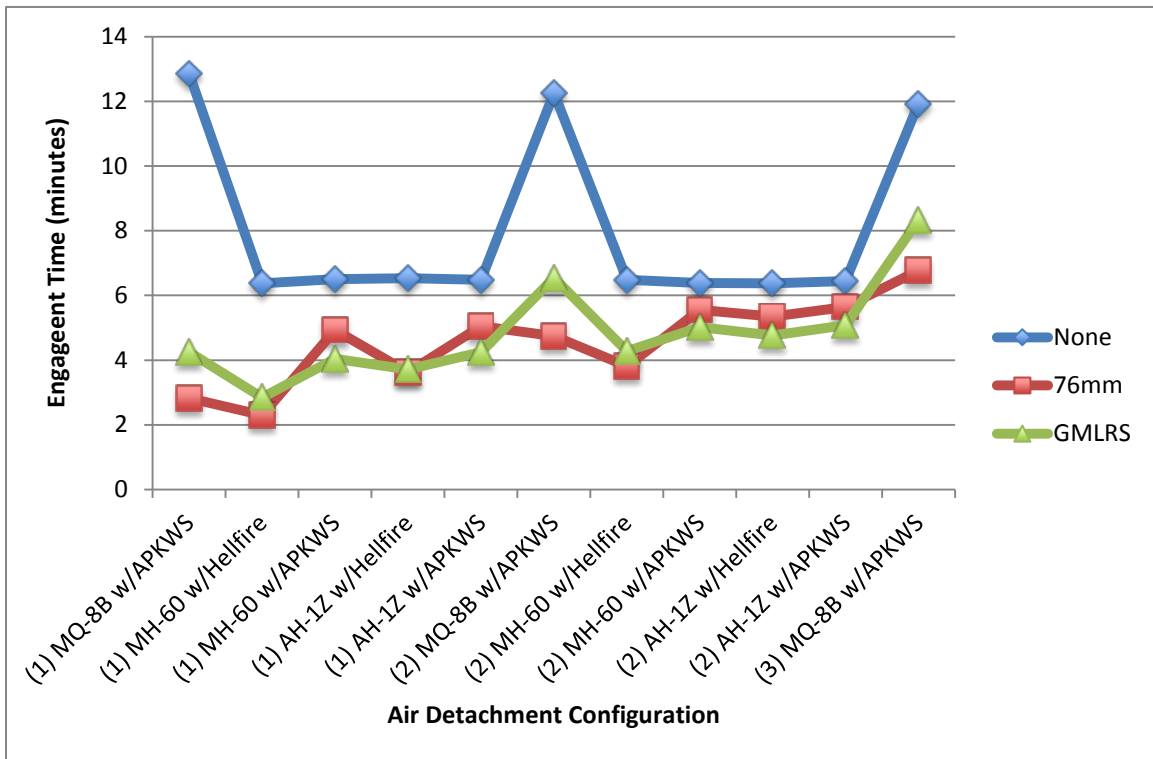

Figure 36 Engagement Time vs. Air Detachment Configuration for each Shipboard Weapon

The different lines in Figure 36 represents different shipboard weapon systems, with each location along the x-axis representing a particular air detachment configuration. The figure provides a single graphic of the effectiveness of each LAMP configuration in terms of average engagement time. The relatively high average engagement time of the “none” line indicates that LAMP configurations without a shipboard weapon system have a higher average engagement time than those configurations with shipboard weapon

systems. The varying levels of the red and green lines, representing the configurations with a 76 mm gun and GMLRS, respectively, suggest that there may not be a significant difference between the two weapon systems in terms of average engagement time.

The mean engagement time of each configuration was assigned a 95% confidence interval in order to identify those configurations with statistically significant differences in average engagement times. As discussed above, this analysis was performed using Tukey’s HSD multiple comparison tests.

The results of the means analysis and multiple comparison tests indicate that, of the currently feasible LAMP configurations, the LAMP configuration with a GMLRS and no air detachment provides the shortest engagement time at 0.2 minutes. The second most effective feasible configuration consists of a 76 mm gun and no air detachment, with an average engagement time of 1.2 minutes. The third most effective feasible LAMP configuration, in terms of average engagement time, consists of a 76mm gun and a MH-60R outfitted with Hellfire missiles at 2.3 minutes. These configurations, as well as the remainder of the top five most effective feasible configurations, are presented in Table 18.

Table 18 Top Five Most Effective Feasible LAMP Configurations in Terms of Average Engagement Time

LAMP configuration	Shipboard Weapon	Air Detachment	Average Engagement Time (minutes) (95% CI)	Rank
7	76mm	(1) MH-60 w/Hellfire	2.30 ± 0.05	1 st
4	76mm	(1) MQ-8B w/APKWS	2.82 ± 0.09	2 nd
8	GMLRS	(1) MH-60 w/Hellfire	2.85 ± 0.06	2 nd
13	76mm	(1) AH-1Z w/Hellfire	3.62 ± 0.08	3 rd
14	GMLRS	(1) AH-1Z w/Hellfire	3.71 ± 0.09	4 th

The ability to deploy two manned aerial assets as part of the LAMP air detachment does not increase the effectiveness of the LAMP in terms of average engagement time. LAMP configurations with two manned aerial assets and either the

76mm gun or the GMLRS have an average engagement time that is statistically higher (i.e., worse) than the configurations listed in Table 18.

3. Percent Affected

The data associated with the 500 samples for each LAMP configuration were also used to calculate a confidence interval for each configuration's average percentage of threats successfully affected. Figure 37 depicts the average percent of threats affected for each shipboard weapon system and air detachment configuration. Each line on the graph represents a potential shipboard weapon, while potential air detachment configurations are captured along the x-axis of the graph.

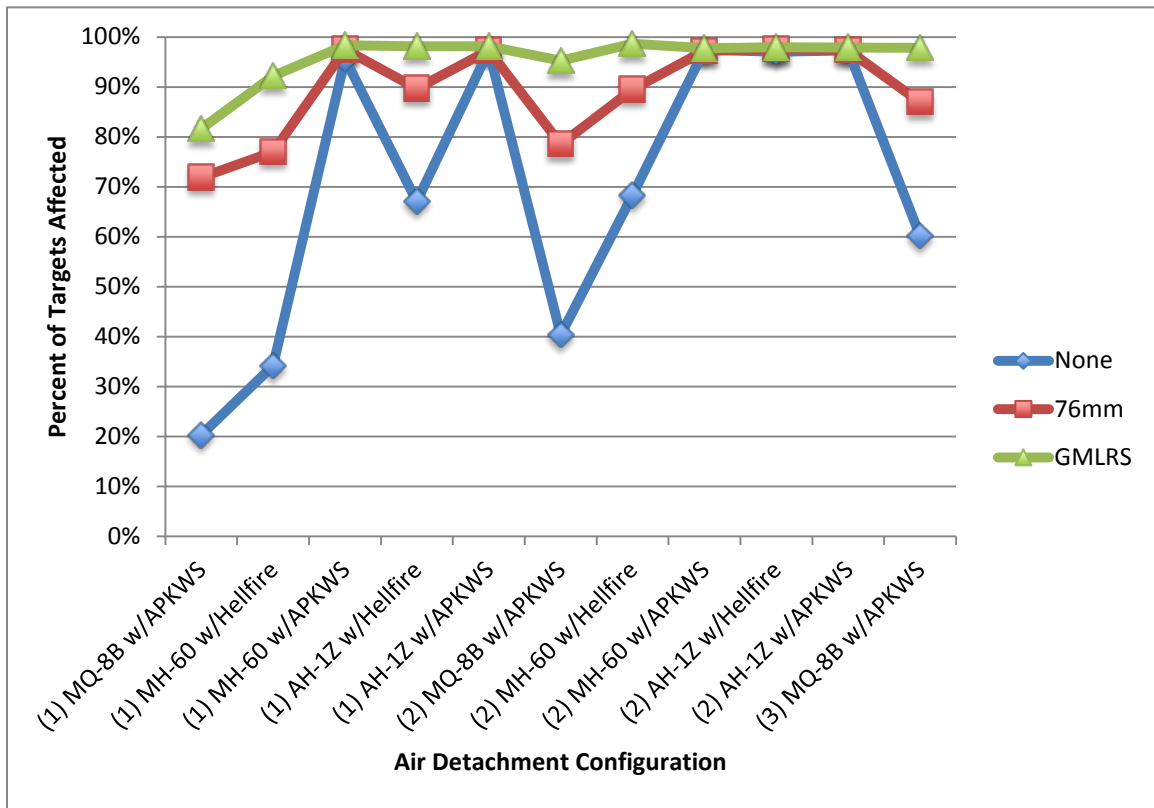

Figure 37 Percent Affected vs. Air Detachment Configuration for each Shipboard Weapon

The different lines in Figure 37 represent different shipboard weapon system, with each location along the x-axis representing a particular air detachment configuration. The figure provides a single graphic of the effectiveness of each LAMP configuration in terms of percentage of targets successfully affected. The relatively low average percentage of targets affected by the “none” configurations suggest that no shipboard weapon system is less effective than those LAMP configurations with a 76 mm gun or a GMLRS shipboard weapon system (represented by the red and green lines, respectively).

The mean percentage of threats affected for each configuration was assigned a 95% confidence interval in order to identify those configurations with statistically significant differences in average percent affected. As discussed above, this analysis was performed using Tukey’s HSD multiple comparison tests.

The results of the means analysis and multiple comparison test indicate that, of the currently feasible LAMP configurations, a range of LAMP configurations are statistically equivalent in terms of their effectiveness at affecting targets. One interesting data point associated with the configurations most effective at affecting targets is that six of the top seven configurations employ air detachments with the APKWS. The top seven LAMP configurations, in terms of percentage of targets engaged, are presented in Table 19; all of the top seven configurations are statistically equivalent at meeting the MOE.

Table 19 Most Effective Feasible LAMP Configurations in Terms of Average Percentage of Targets Successfully Affected

LAMP configuration	Shipboard Weapon	Air Detachment	Average Percent Affected (95% CI)	Rank
11	GMLRS	(1) MH-60 w/APKWS	0.983 ± 0.002	1 st
14	GMLRS	(1) AH-1Z w/Hellfire	0.981 ± 0.003	1 st
17	GMLRS	(1) AH-1Z w/APKWS	0.981 ± 0.002	1 st
35	GMLRS	(3) MQ-8B w/APKWS	0.978 ± 0.003	1 st
10	76mm	(1) MH-60 w/APKWS	0.975 ± 0.003	1 st
16	76mm	(1) AH-1Z w/APKWS	0.973 ± 0.003	1 st
15	None	(1) AH-1Z w/APKWS	0.973 ± 0.003	1 st

The ability to deploy two manned aerial assets as part of the LAMP air detachment would not significantly impact the LAMP effectiveness in terms of successfully affecting targets. This result is based on the high effectiveness of the LAMP configurations with a single manned aviation asset in terms of affecting targets; adding an additional manned asset to the configuration does not statistically increase the effectiveness of the configuration at successfully affecting targets.

D. COST ESTIMATION

Cost estimation is a necessary step in identifying the most cost-effective solution at meeting a given objective. The total cost for acquisition and ownership of each potential LAMP configuration over its useful life was estimated in order to develop life-cycle cost estimates for each configuration in support of identifying the most cost-effective LAMP configuration at providing fires employment and ISR&T data collection in support of amphibious operations. The useful life for the LAMP was assumed to be equal to the service life of the LCS, which is 25 years (U.S. DOD 2012).

For this analysis, the life-cycle costs (LCCs) of alternative solutions were estimated in order to understand the total cost of a system over its lifetime, rather than just the initial cost to procure it. The analysis generated LCCs that include the costs associated with research, development, procurement, and installation of the system, as well as the manpower needed to operate the system, the personnel and equipment necessary to maintain the system, and the personnel and equipment necessary to meet the training requirements associated with the system. These categories are described in greater detail below:

- **Research and Development (R&D):** This category includes the cost of all research and development, from program initiation through the Full Rate Production
- **Procurement:** This is the cost to purchase the system from a vendor.
- **Operation and support (O&S):** The bulk of life-cycle costs occur during this category. It covers the cost of operating and supporting the fielded system. O&S includes personnel requirements, maintenance, training, the cost to replenish spares, ammunition costs and fuel costs to operate the aerial assets over a 25 year life cycle.

A cost breakdown structure (CBS) was created to display the cost contributors of the LAMP in a graphical depiction. Figure 38 displays a general CBS for the potential solutions; the costs of each element in the CBS for each asset associated with a given LAMP configuration are summed in order to calculate the LCCE of each potential LAMP configuration. Each potential solution is slightly different, for example: the MK 75 76 mm gun maintenance is only performed at the intermediate and depot level, while other systems have maintenance at the organizational, intermediate and organization levels. This analysis considered alternatives with no shipboard weapon system or no air detachments, so the initial ammunition load-out is estimated separately for air weapons and shipboard weapons.

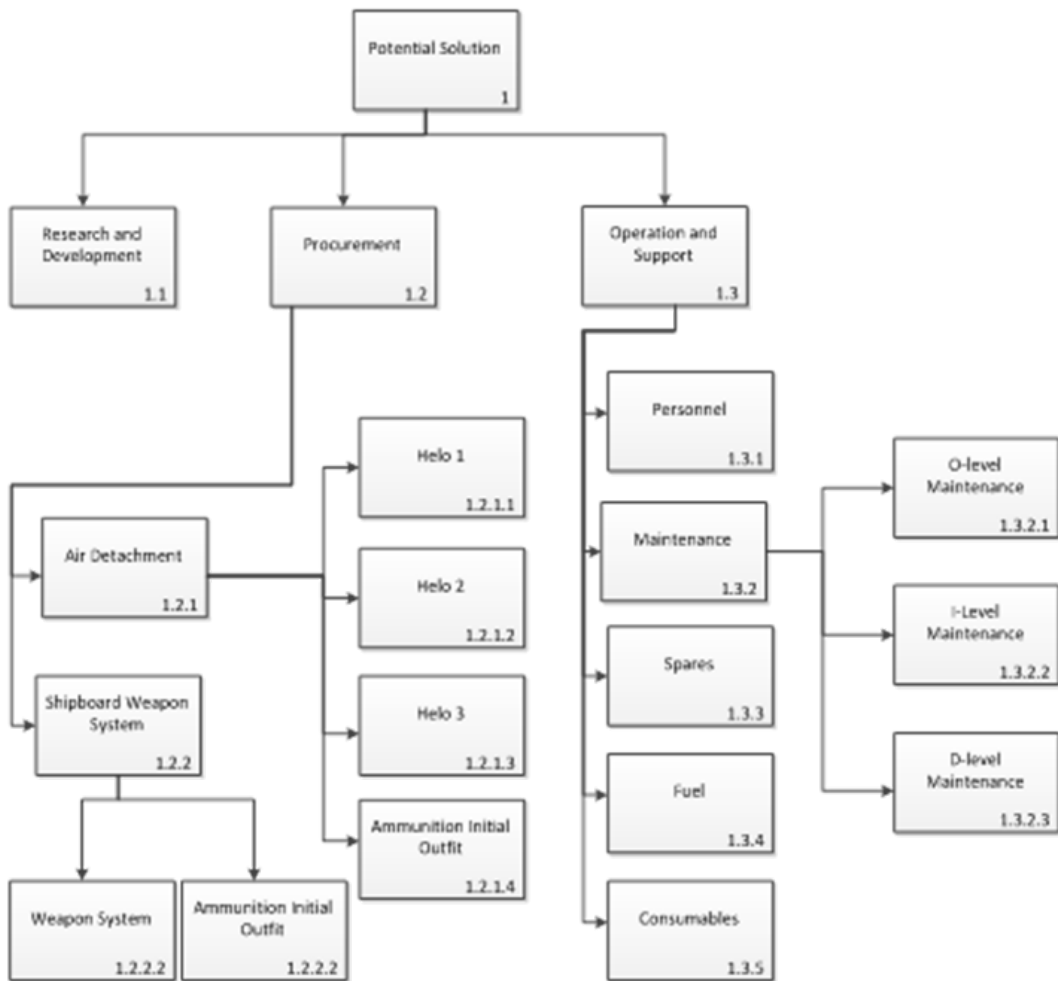

Figure 38 LAMP Cost Breakdown Structure

1. Research and Development

For this analysis, all of the assets considered in the potential solutions are existing systems that have already been deployed for military use. Therefore, it is assumed the only research and development costs associated with the LCC of the potential solutions proposed is the cost to integrate the existing systems onto an LCS and to verify the results of that integration effort. The cost estimate for the R&D required to integrate existing systems was estimated based upon existing LCS mission module integration efforts, specifically the gun mission module R&D costs of \$6.36M (U.S. Navy 2014e). Aerial assets are already deployed aboard LCS and are therefore assumed to not impact the R&D cost estimate for a given LAMP configuration. Similarly, because the evaluated air asset weapons are already deployed on the considered air assets, the air asset weapon associated with a given configuration does not impact the estimated R&D costs.

2. Procurement

The procurement cost of each potential asset was determined based on the DOD's current and past fiscal year (FY) budgets for the Navy or Army (as appropriate for the given asset) to determine the overall procurement cost of each configuration and the initial outfitting of ammunition for each. In this evaluation, it has been assumed that each aerial asset is procured with a quantity of one full load-out of munitions to be initially outfitted aboard each asset within a configuration. The C2 for the systems, as well as the logistics support, were considered part of the procurement costs of each system based on the procurement breakdown in the budget data. Past FY data was converted to current FY dollars to provide an accurate comparison of each solution. This conversion calculation was based on the Naval Center for Cost Analysis Joint Inflation Calculator. This source uses an inflation factor to determine the current FY cost based on the then-year cost.

As discussed previously, it has been estimated that an LCS is capable of storing 77 Hellfire missiles or 231 APKWS rockets. For the air platforms containing APKWS, this equates to 38 reloads for the configurations utilizing the MQ-8B, six reloads for the configurations utilizing the MH-60R, or three reloads for the configurations utilizing the AH-1Z. For the air platforms containing Hellfire missiles, this equates to nine reloads for

the configurations including the MH-60R and four reloads for the configurations including the AH-1Z. These quantities were considered when determining the initial outfitting costs of ammunition for the APKWS and Hellfire missiles to be stored aboard the LCS, separate from the one full load-out initially outfitted on each aerial asset. The APKWS magazine contains six rockets on a MQ-8B platform, 38 rockets on a MH-60R platform, and 76 rockets on an AH-1Z platform; while the Hellfire magazine contain eight missiles on a MH-60R platform and 16 missiles on an AH-1Z platform. For example, an AH-1Z equipped with APKWS will cost \$33.73M for each aerial asset purchased plus \$2.17M for the initial outfitting of one full load-out of weapons per asset, totaling \$35.90M per asset (U.S. Army 2013). The LCS will also store three magazines containing 76 APKWS rockets that will cost \$6.51M to initially outfit the LCS, independent of the quantity of aerial assets within a configuration (U.S. Navy 2014f).

As defined by the LAMP physical solutions, a LCS is capable of carrying 1 magazine for the ammunitions used by the MK 75 76 mm gun, which has a capacity of 800 rounds; LCS is capable of carrying 2 magazines for the GMLRS, which contains six missiles per magazine.

A peacetime cost estimate must also include the procurement of war reserves, which are designed to cover the period at the beginning of a war before the economy and military procurements are able to replace the materiel consumed during the war (Surmeir 1969). Based upon the expected use of the LAMP captured in the DRM, the maximum wartime reserve per LAMP would be two full load outs of the magazines. These costs are included in the table below, in the ammunition initial outfitting costs for shipboard weapon systems, and in the LCS initial outfitting costs at the bottom of the table for air assets.

The procurement and installment costs per unit for each of the systems can be found in Table 20 and are reported in FY14 dollars. These costs are listed per air asset or weapon system, and including initial ammunition loadouts as well as war reserves. LAMP configurations containing more than one air asset would experience lower per-asset costs due to the LCS magazine size remaining the same regardless of the number of air assets employed.

Table 20 System Procurement Costs (after Oestergaard 2014a, U.S. Army 2013, U.S. Navy 2014f, U.S. Navy 2014g, U.S. Navy 2014h, and U.S. Navy 2011b)

System	Total Procurement Cost
MK 75 76 mm Gun	\$11,480,233
GMLRS w/ M-30	\$8,053,800
MQ-8B w/ APKWS	\$56,753,300
MH-60R w/ Hellfire	\$59,985,200
MH-60R w/ APKWS	\$57,697,540
AH-1Z w/ Hellfire	\$55,008,400
AH-1Z w/ APKWS	\$55,443,200

3. Operation and Support

a. Manpower

The manpower cost estimate includes the costs associated with the required labor for military personnel to operate the system. Manpower was considered extra manpower required to operate the aerial assets and shipboard weapon systems; this analysis assumes that the missiles and rockets associated with a given LAMP configuration do not require additional manpower requirements beyond what is captured in the maintenance and training costs. Labor costs associated with the maintenance and training of the system are covered in the sections below, since the information was obtained from separate sources. To calculate the manpower cost estimates, the personnel requirements were collected from military sites identifying the operator requirements. Composite yearly salaries were used to determine the manpower costs to operate the system based on the personnel required to operate the systems. These salaries were obtained from the Department of the Navy section of the FY 2014 DOD Military Personnel Composite Standard Pay and Reimbursement Rates. The annual DOD composite rate was used for personnel costs--this rate includes average basic pay plus accrual, Medicare-eligible retiree health care accrual, basic allowance for housing, basic allowance for subsistence, incentive and special pay, permanent change of station expenses and miscellaneous pay (U.S. DOD 2013). Table 21 shows the quantity of military personnel and yearly salaries of the personnel required to operate each of the systems.

Table 21 Operations Manpower Estimates (after U.S. DOD 2013)

System	Required Personnel	Yearly Cost	Life Cycle Personnel Cost (25 Years)
76 mm Gun	1 E-4, 4 E-2	\$257,492	\$6,437,300
GMLRS	1 E-4, 1 E-5, 1 E-6	\$248,236	\$6,205,900
MQ-8B	2 O-2	\$237,436	\$5,935,900
MH-60R	2 O-2	\$237,436	\$5,935,900
AH-1Z	2 O-2	\$237,436	\$5,935,900

For this analysis, it has been assumed that the manpower cost estimate also considers training costs of the operator. It has been assumed that, based on the required personnel rank and rating or military occupational specialty, the operators are considered trained to operate the systems; therefore separate training costs have not been considered by this analysis.

b. Maintenance

Maintenance occurs at the Organizational, Intermediate, and Depot levels. It is an important factor in the LCC of each of the systems. These values were obtained through the Navy visibility and management of operating and support costs (VAMOSOC) for the Navy related items, as well as the Army Operating and Support Management Information System (OSMIS) for Army related items. The Navy and Army track the LCC areas of their systems and report them in VAMOSOC and OSMIS, in order to be used to analyze different systems. Labor costs were collected for the most recent five years' worth of maintenance for each of the assets associated with the potential solutions. Maintenance can vary from year to year, so the average was used to ensure that the estimates were not inflated or underestimated due to a year with abnormally high or low maintenance requirements. These values were divided by the quantity of systems for each year to determine the average maintenance costs for each system, and then averaged to determine the average yearly maintenance costs for each system. The cost estimate assumed that missiles themselves do not require any maintenance—they are either successfully fired or disposed of as unusable. The estimate also assumed that the missiles do not have a limited service life that requires them to be periodically assessed or serviced.

To account for the difference in helicopter flight hours per year, the helicopter values were broken down into maintenance costs per hour of flight time, then considered for 200 flight hours per asset. These 200 flight hours account for required exercises that occur throughout the year. For example, the AH-1Z averages 131 flight hours per year, while the MH-60R averages 346 flight hours per year (U.S. Navy 2014d). This likely causes more maintenance to be performed on the MH-60R than on the AH-1Z. By using the ratio of flight hours for 200 hours, the values are compared more fairly, since the missions for each helicopter will be the same for LAMP. Table 22 displays the average yearly maintenance costs.

Table 22 Maintenance Costs (after U.S. Army 2014b; U.S. Navy 2014d)

System	Average Yearly Maintenance Cost	Life Cycle Maintenance Cost (25 Years)
76 mm Gun	\$28,444	\$711,106
GMLRS	\$67,880	\$1,696,960
MQ-8B	\$175,000	\$4,375,000
MH-60R	\$982,300	\$24,557,494
AH-1Z	\$1,118,195	\$27,954,886

c. Training

As discussed in the manpower section, it is assumed that operators have already been trained to operate and maintain the systems. For purposes of this evaluation, it has been assumed that costs to cross-train personnel to maintain the systems are similar in costs; therefore, it will not provide additional cost difference in a system, and has not been considered in the cost estimation.

d. Spares

The costs of spares for each asset are reported separately from the maintenance costs which reports only the costs of labor to perform period scheduled and unscheduled maintenance. These values are reported in VAMOSC and OSMIS. Therefore, these costs were obtained from these two sources. The same method was used to gather spares cost

as was used for the maintenance costs. Cost were obtained over five years, and then averaged for the quantity of systems. In the case of the helicopters, these values were determined by flight hours, and normalized over 200 flight hours per asset. These values are displayed in Table 23.

Table 23 Spares Costs (after U.S. Army 2014b and U.S. Navy 2014d)

System	Average Yearly Spares Cost	Life Cycle Spares Cost (25 Years)
76 mm Gun	\$77,290	\$1,932,250
GMLRS	\$32,957	\$823,920
MQ-8B	\$222,620	\$5,565,530
MH-60R	\$17,620	\$440,499
AH-1Z	\$30,054	\$751,338

e. Ammunition

The LCCE must also include ammunition expenditure for each asset. Even when not in wartime use, there will be live fire demonstrations, training exercises, and test events to verify full system functionality after new installations or major system repairs. For purposes of this evaluation, it has been assumed that 200 rounds of gun ammunition, and 20 missiles per air or shipboard weapon system are expended per year.

Costs per round were obtained from Navy and Army budget documents. The initial magazine costs for outfitting the LCS magazines and procuring war reserves were calculated based on these costs per round. This cost is dependent only upon the munition type; the initial ammunition outfitting of each air asset is included in its procurement cost. Yearly costs were then calculated, based upon the cost per round and the expected peacetime expenditure rate, with total costs over the 25-year life span of an LCS determined from these yearly costs. The ammunition costs are shown in Table 24.

Table 24 Ammunition Costs (after U.S. Army 2013; U.S. Navy 2014g; U.S. Navy 2014h)

System	Yearly Cost	Total Cost (25 Years)
MK 75 76 mm Gun	\$229,600	\$5,740,000
GMLRS with M30	\$2,541,000	\$63,525,000
MQ-8B with APKWS	\$571,400	\$14,285,000
MH-60R with Hellfire	\$2,046,000	\$51,150,000
MH-60R with APKWS	\$571,400	\$14,285,000
AH-1Z with Hellfire	\$2,046,000	\$51,150,000
AH-1Z with APKWS	\$571,400	\$14,285,000

f. Fuel

Each aerial asset, while deployed, includes fuel costs required to operate. The data for yearly fuel costs for AH-1Z and MH-60R were pulled from VAMOSC, which reports total yearly fuel costs. This data was divided by the total flight hours flown by the systems deployed and then multiplied by the assumed 200 flight hours flown per asset per year.

Fuel cost data was not available for the MQ-8B or other analogous unmanned aerial vehicles. Therefore, the cost was determined based on a ratio compared to the AH-1Z. Due to the difference in size, weight and speed, the MQ-8B, with the same amount of flight time, is assumed to use one-fifth of the fuel as the AH-1Z. This assumption is based on the fact that the MQ-8B is half the size, one-sixth of the weight, and cruises at two-thirds of the speed of the AH-1Z (Oestergaard 2014b and Oestergaard 2014c). The average fuel cost per asset is displayed in Table 25.

Table 25 Fuel Costs (after U.S. Navy 2014d)

System	Average Yearly Fuel Cost	LCC Fuel Cost (25 Years)
MQ-8B	\$19,965	\$499,140
MH-60R	\$102,788	\$2,569,690
AH-1Z	\$99,828	\$2,495,704

4. Overall System Cost Estimation

The analysis of the cost is based on the LCCE for each alternative. The key drivers impacting the overall cost are analyzed by life-cycle phase. The total costs for each potential LAMP asset are presented in Table 26; the LAMP configurations and their associated LCCs are shown in Table 27. The asset costs include the R&D, procurement, and O&S costs discussed above (including initial ammunition loadout and wartime reserve costs).

Table 26 Asset LCCE Comparison

System	R&D	Procurement	O&S	Total
MK 75 76 mm Gun	\$6,636,000	\$11,480,233	\$14,820,658	\$32,896,891
GMLRS & M-30 Rocket	\$6,636,000	\$8,053,800	\$71,911,125	\$86,600,925
MQ-8B w/ APKWS	\$0	\$56,753,300	\$30,660,572	\$87,413,872
MH-60R w/ Hellfire	\$0	\$59,985,200	\$84,653,584	\$144,638,784
MH-60R w/ APKWS	\$0	\$57,697,540	\$47,788,584	\$105,486,124
AH-1Z w/ Hellfire	\$0	\$55,008,400	\$88,287,878	\$143,296,228
AH-1Z w/ APKWS	\$0	\$55,443,200	\$51,422,828	\$106,866,028

Table 27 LAMP Configuration LCCEs

LAMP Configuration	Air Detachment	Shipboard Weapon System	Total Cost
0	None	None	\$0
1	None	76 mm Gun	\$32,936,891
2	None	GMLRS	\$86,600,925
3	(1) MQ-8B w/APKWS	None	\$87,413,872
4	(1) MQ-8B w/APKWS	76 mm Gun	\$120,350,763
5	(1) MQ-8B w/APKWS	GMLRS	\$174,014,797
6	(1) MH-60 w/Hellfire	None	\$144,638,784
7	(1) MH-60 w/Hellfire	76 mm Gun	\$177,575,675
8	(1) MH-60 w/Hellfire	GMLRS	\$231,239,709
9	(1) MH-60 w/APKWS	None	\$105,486,124
10	(1) MH-60 w/APKWS	76 mm Gun	\$138,423,015
11	(1) MH-60 w/APKWS	GMLRS	\$192,087,049
12	(1) AH-1Z w/Hellfire	None	\$143,296,228
13	(1) AH-1Z w/Hellfire	76 mm Gun	\$176,233,119
14	(1) AH-1Z w/Hellfire	GMLRS	\$229,897,153
15	(1) AH-1Z w/APKWS	None	\$106,866,028
16	(1) AH-1Z w/APKWS	76 mm Gun	\$139,802,919
17	(1) AH-1Z w/APKWS	GMLRS	\$193,466,953
18	(2) MQ-8B w/APKWS	None	\$155,285,864
19	(2) MQ-8B w/APKWS	76 mm Gun	\$188,222,755
20	(2) MQ-8B w/APKWS	GMLRS	\$241,886,789
21	(2) MH-60 w/Hellfire	None	\$267,180,767
22	(2) MH-60 w/Hellfire	76 mm Gun	\$300,117,658
23	(2) MH-60 w/Hellfire	GMLRS	\$353,781,692
24	(2) MH-60 w/APKWS	None	\$191,430,367
25	(2) MH-60 w/APKWS	76 mm Gun	\$224,367,258
26	(2) MH-60 w/APKWS	GMLRS	\$278,031,292
27	(2) AH-1Z w/Hellfire	None	\$266,950,856
28	(2) AH-1Z w/Hellfire	76 mm Gun	\$299,887,747
29	(2) AH-1Z w/Hellfire	GMLRS	\$353,551,781
30	(2) AH-1Z w/APKWS	None	\$194,190,176
31	(2) AH-1Z w/APKWS	76 mm Gun	\$227,127,067
32	(2) AH-1Z w/APKWS	GMLRS	\$280,791,101
33	(3) MQ-8B w/APKWS	None	\$223,157,856
34	(3) MQ-8B w/APKWS	76 mm Gun	\$256,094,747
35	(3) MQ-8B w/APKWS	GMLRS	\$309,758,781

THIS PAGE INTENTIONALLY LEFT BLANK

V. ANALYSIS OF ALTERNATIVES

With models established and cost estimation data collected, the project focused on answering the remaining research questions: can LCS provide (cost-)effective joint fire support? This question was first considered by collecting simulation data from the discrete-event model described in Chapter IV in order to identify the most effective LAMP configuration(s). With mission effectiveness established, the project included consideration of cost data (also discussed in Chapter IV) in order to identify the most cost-effective LAMP configuration(s). This chapter presents the results of these considerations in order to identify the LAMP configuration(s) most effective at providing fires employment and ISR&T data collection in support of amphibious operations.

With three MOEs selected for this study and with certain criteria required by the various capabilities documents, the first down select of configuration alternatives was based on the need for sufficing the LAMP configuration against the operational requirements listed in the various capabilities documents. This approach, described by Blanchard and Fabrycky, is referred to as comparing alternatives against a standard. For this project, the down-select rule used in support of comparing alternatives against standard was based on the threshold values of the appropriate operational requirements, since any achievable objective requirement was considered to be in the acquisition manager's trade space.

The rule used for this was that a LAMP configuration could only be retained if it meets all the operational requirement standards to at least the threshold value for easily determined requirements for: weapon system sustained rate of fire, weapon system range, and for ISR&T range. This approach excluded LAMP configurations 0, 1, and 2 from further consideration due to the lack of the necessary ISR&T range, a result of not having air detachments associated with these configurations.

Comparing alternatives against a standard could not be employed for the operational requirements that generated the MOEs for probability of targets detected, time for engagement and probability of targets affected. Since these MOEs required

modeling and simulation, another method beyond comparing alternatives against a standard was required.

This project evaluated each LAMP configuration in terms of a given configuration's overall measure of effectiveness (OMOE). A configuration's OMOE was calculated by converting the configuration's MOE mean values to utility scores, multiplying each of those utility scores by a swing weight (equal swing weights were used for each utility score associated with a given configuration), and summing those values. This approach resulted in OMOE values that range between zero and one, with zero being the worst and one indicating a perfectly effective configuration.

Two of the three MOEs were evaluated as a percentage (i.e., MOEs 1 and 3), precluding the need to convert those values to utility scores; the mean of the measured values was used as the utility score. Engagement time (MOE 2), however, required the development of a utility curve to convert time into a percentage that could be weighted and then added to the other two MOEs. From the ICD for Joint Fires, ten minutes was the stated maximum acceptable time. For this evaluation, an engagement time of one minute or less was assigned a perfect score of 1.0, while ten minutes or greater was assigned a score of 0.0; a linear function was used to characterize the utility curve between an engagement time of one and ten minutes. Figure 39 is a plot of the utility curve used to convert engagement time to a utility score.

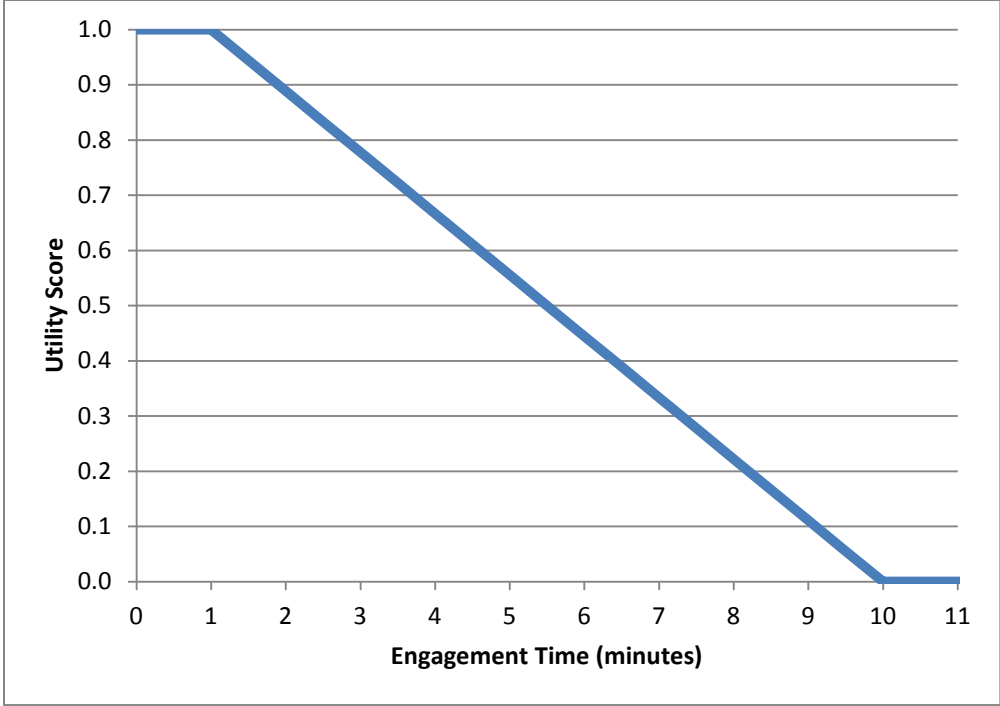

Figure 39 MOE 2 Utility Curve

With each MOE expressed as a percentage, a weighted method of evaluation was employed to calculate an overall MOE score for each data point collected during simulation. Since it was not possible to gain consensus across a broad range of stakeholders, the weighting factors of each MOE were rated equally and were each multiplied by a factor of 0.33 (with all three weighting factors summing up to one).

By calculating an OMOE for each simulation data point, the project was able to identify statistically significant differences between the OMOE scores of multiple LAMP configurations. Figure 40 presents a stack chart of the OMOE scores of the various LAMP configurations; Table 28 provides the top five most effective LAMP configurations as determined by this project.

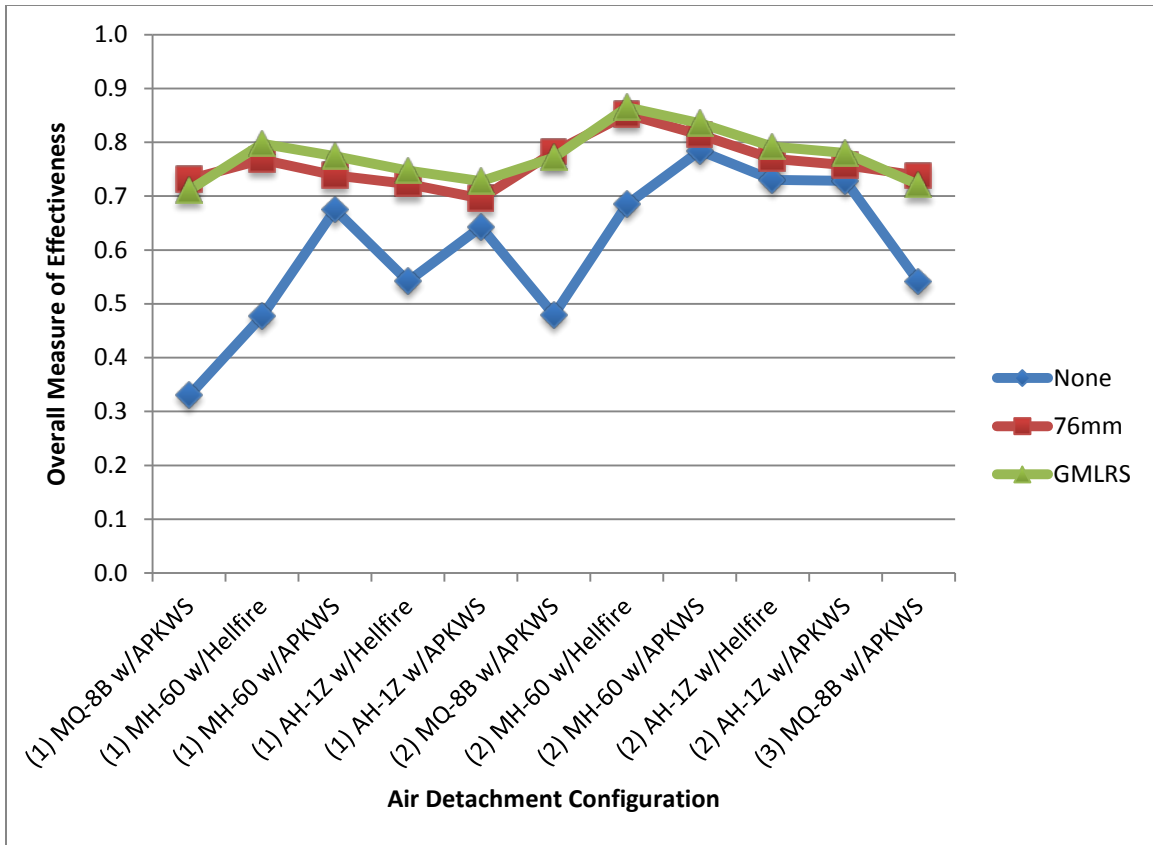

Figure 40 LAMP Configurations' OMOE Comparison

Table 28 Top Five Most Effective Feasible LAMP Configurations in terms of OMOE

LAMP configuration	Shipboard Weapon	Air Detachment	OMO (95% CI)	Rank
8	GMLRS	(1) MH-60 w/Hellfire	0.80 ± 0.01	1 st
19	76mm	(2) MQ-8B w/APKWS	0.78 ± 0.01	2 nd
11	GMLRS	(1) MH-60 w/APKWS	0.77 ± 0.01	2 nd
20	GMLRS	(2) MQ-8B w/APKWS	0.77 ± 0.01	2 nd
7	76mm	(1) MH-60 w/Hellfire	0.77 ± 0.01	2 nd

The ability of the LAMP to deploy two manned air assets significantly impacts the overall effectiveness of the LAMP providing fire support and ISR&T data collection. The results of this evaluation indicate that a LAMP with two MH-60R air assets with

Hellfire missiles and either shipboard weapon system would have an overall effectiveness of 0.85-0.87.

With OMOE scores calculated and the LCCEs for each configuration established, as discussed previously, the project plotted LCCEs against configuration OMOE scores. The resultant chart, provided as Figure 41, allowed for the identification of “dominated” solutions, i.e., solutions that are not as effective as cheaper alternatives. Alternatively, “non-dominated” solutions were also identified in order to reduce the trade-space of potential solutions. In Figure 41, the non-dominated solutions are shown as blue diamonds, while the dominated solutions are presented as red squares; infeasible solutions (i.e., solutions with two manned air assets) are presented as green triangles.

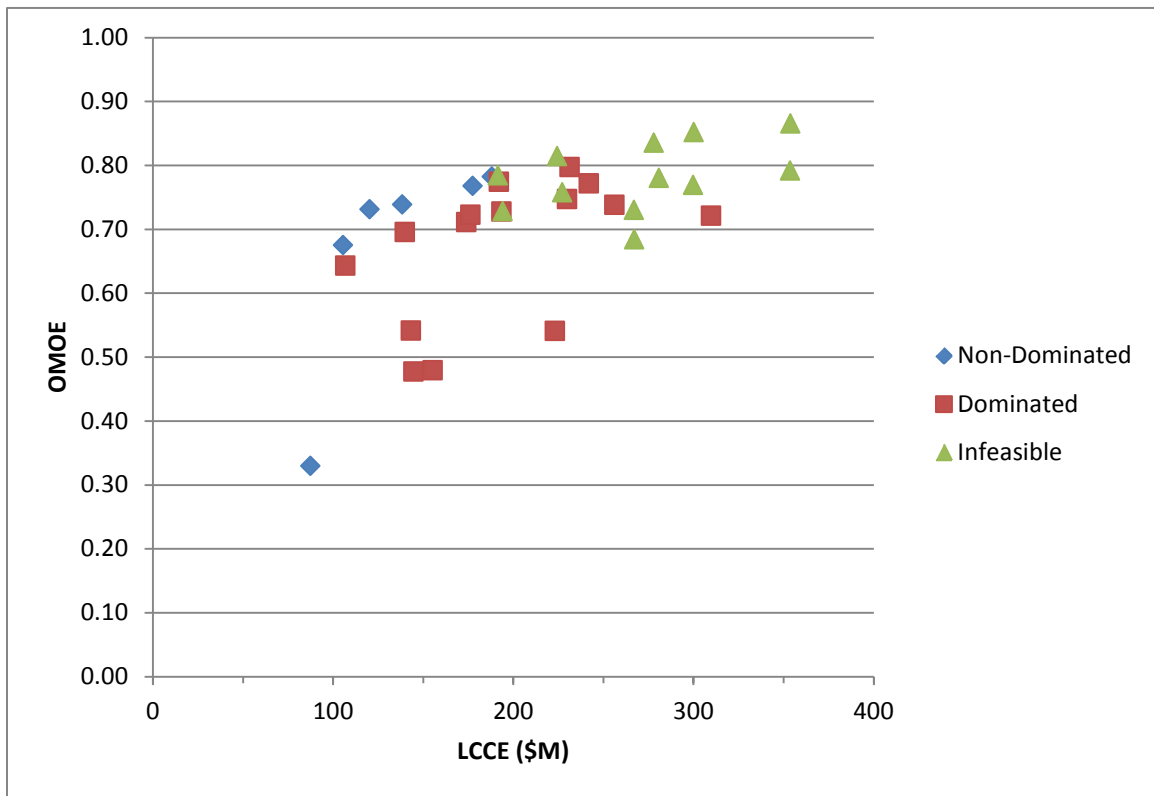

Figure 41 LAMP LCCE vs. OMOE

There are a total of six LAMP configurations that are non-dominated solutions; the data associated with these configurations is provided in Table 29.

Table 29 Non-Dominated LAMP Alternatives

Configuration	3	9	4	10	7	19
Shipboard Weapon System	None	None	76 mm	76 mm	76 mm	76 mm
Air Detachment	(1) MQ-8B w/APKWS	(1) MH-60R w/APKWS	(1) MQ-8B w/APKWS	(1) MH-60R w/APKWS	(1) MH-60R w/Hellfire	(2) MQ-8B w/APKWS
Percent Detected	0.70	0.70	0.70	0.70	0.70	1.00
Engagement Time (minutes)	12.85	6.50	2.82	4.93	2.30	4.75
Percent Affected	0.20	0.96	0.72	0.98	0.77	0.79
OMOE	0.3	0.7	0.7	0.7	0.8	0.8
LCCE (\$M)	\$ 87.4	\$ 105.49	\$ 120.35	\$ 138.42	\$ 177.58	\$ 188.22

Results of the analysis indicate that a cost-effective LAMP does not consist of an AH-1Z helicopter, regardless of weapon load-out, nor do any of the cost-effective LAMP configurations consist of a GMLRS; all of the other shipboard weapon system configurations (none or the 76 mm gun) and air assets (MQ-8B w/APKWS, MH-60R w/Hellfire, and MH-60R w/APKWS) appear in one or more of the non-dominated alternatives. The least effective non-dominated solution, a single MQ-8B with no shipboard weapon system, provides significantly less effectiveness than the next-expensive alternative (a single MH-60R equipped with APKWS rockets with no shipboard weapon system). These two lowest-cost alternatives make sense—the smallest barrier to entry for the LCS to support amphibious operations is the deployment of an air asset to collect ISR&T data and employ fires.

Two of the non-dominated solutions provide questionable value (i.e., effectiveness) for a particular LCCE. For example: Alternative 3 provides an

effectiveness of just 0.3 at a cost of \$87.4M; for an additional ~\$20M, the LAMP would be anticipated to achieve LAMP effectiveness of 0.67—almost a 100% increase in effectiveness for only a ~20% increase in LCC. This drastic difference between Alternatives 3 and 9 is used as justification for eliminating Alternative 3 from final recommendations. Further, Alternative 19 provides very little benefit over Alternative 7, but is estimated to cost over \$10M more over the expected life-cycle. For this reason, Alternative 19 has been eliminated from inclusion in the final recommendation.

Elimination of Alternatives 3 and 19 from the final group of recommended solutions resulted in the identification of five alternatives (9, 4, 10, and 7) that may, overall, provide cost-effective joint fire support. Each of the four alternatives had an equivalent MOE 1 value of 70%. MOE 2 provides a point of distinction between the five alternatives, as does MOE 3. Alternatives 4 and 7 provide a relatively low average engagement time of less than three minutes, while the least expensive alternative only provides an average engagement time of ~6.5 minutes. Alternatively, the cheapest of the four solutions (Alternative 9) provides one of the highest estimated percentage of threats successfully affected, and does so with an average engagement time that meets the objective MOE 2 value by a healthy margin (30%). A final recommendation may be supported by greater insight to any potential differences between the swing weights associated with each of the MOEs considered by this project.

There are four infeasible solutions (i.e., solutions with two manned air assets) that are non-dominated: Alternatives 25, 26, 22, and 23. All four of these alternatives utilize two MH-60R air assets; the four alternatives provide different combinations of the 76 mm or GMLRS shipboard weapon system and Hellfire or APKWS air weapons. The configuration utilizing APKWS rockets and a 76 mm gun is estimated to cost ~\$75M less than the configuration utilizing Hellfire missiles for a relatively equivalent level of effectiveness (in terms of all MOEs and OMOE). The alternatives utilizing GMLRS appear to be more effective than the configurations utilizing the 76 mm gun, all other parameters equal.

This analysis indicates that the additional cost of a second manned air asset does not provide a significant increase in specific nor overall effectiveness, since configuration

19 has an OMOE of 0.78 but with a LCCE over \$35M less than the least-expensive two-manned-aircraft non-dominated alternative (with a LCCE of ~\$225M and an OMOE of 0.81).

This analysis also provides some insight to the effectiveness of three unmanned aircraft versus two manned aircraft. With three unmanned aviation assets, Alternatives 33, 34 and 35 offer a glimpse of unmanned ISR&T coupled with a shooter, while configuration 34 (72mm gun with three MQ-8Bs with APKWS) has the highest OMOE (.74) at a LCCE just over \$250M. However, this configuration is dominated by alternatives utilizing two manned air assets—as are the other alternatives utilizing three unmanned air assets.

VI. CONCLUSIONS

This project considered whether or not a LAMP could perform ISR&T data collection and fires employment in support of amphibious operations. These missions were selected through an analysis of capability gaps documented in ICDs and the POM-16 MCGL. The LCS platform was considered due to its flexibility in deploying systems focused on a particular mission as part of a MP. As part of this consideration, the following research questions were addressed:

- What threats exist for an ARG/MEU during amphibious operations?
- What alternatives exist for providing joint fires capability with a LCS MP?
- Could LCS provide effective joint fire support?
- What would the most cost-effective LCS mission package be to support amphibious operations?

In order to address the questions listed above, this project defined and executed a tailored SE process that included problem space analysis, identification of alternatives, modeling and simulation, and an analysis of alternatives. Each phase focused on answering a different research question.

A. WHAT THREATS EXIST FOR AN ARG/MEU DURING AMPHIBIOUS OPERATIONS?

Problem space analysis included the identification of threats to the ARG/MEU during amphibious operations. As discussed in the DRM in Chapter II, threats to the ARG/MEU during amphibious operations included armored and unarmored, fixed and mobile targets. The representative threat for this project was a mechanized infantry brigade, consisting of ten battalions of a range of threats. The force level of the threat was estimated at 5,000 units.

The DRM provided additional details regarding the expected operational environment of the LAMP, including environmental and geographic conditions. These characteristics of the operating environment were used to derive operational requirements that the LAMP would be expected to meet in providing ISR&T data collection and fires

employment in support of amphibious operations. These operational requirements were presented at the end of Chapter II.

B. WHAT ALTERNATIVES EXIST FOR PROVIDING JOINT FIRES CAPABILITY WITH A LCS MP?

With the operational requirements established, this project transitioned to the identification of alternatives for providing joint fires capability with a LCS MP. Alternative identification was based on the operational activities originally identified during DRM development which were, in turn, tied to capability areas related to the originally identified capability gaps of ISR&T data collection and fires employment. Operational activities were allocated to the LAMP and further described in terms of the external activities that the LAMP would be expected to interface with. This process, presented in Chapter III, resulted in definition of the LAMP operational architecture.

The LAMP operational architecture, in turn, was used to develop the LAMP functional and physical architectures in order to specifically answer the question of what alternatives exist for providing joint fires capability with a LCS MP. The results of this functional analysis and allocation, described in Chapter III, include a physical architecture that consists of four elements: a shipboard weapon system, an air detachment, a C2 system, and a logistics support system. The allocation of LAMP functions to each of these elements was used to derive functional requirements for each of the elements and to identify existing systems that would meet those requirements.

In turn, systems currently deployed by the DOD were evaluated to identify those systems that meet the requirements allocated to the shipboard weapon system and air assets that make up the LAMP air detachment. Those systems identified for consideration as potential shipboard weapon systems include:

- 76 mm gun
- GMLRS

Those systems identified for consideration as potential air assets include:

- MQ-8B Firescout with APKWS rockets
- MH-60R Seahawk with Hellfire missiles

- MH-60R Seahawk with APKWS rockets
- AH-1Z Viper with Hellfire missiles
- AH-1Z Viper with APKWS rockets

C. COULD LCS PROVIDE EFFECTIVE JOINT FIRE SUPPORT?

As part of LAMP alternative identification, the feasible configurations of these shipboard weapon systems and air assets were defined by considering the requirements associated with a LCS MP as well as other limitations associated with the logistics support of a LAMP configuration. These considerations resulted in the identification of 36 potential LAMP configurations that would provide joint fires in support of amphibious operations, as described in Chapter IV, Section A.

The next research question that this project focused on was whether or not any of the identified configurations would provide effective fire support for amphibious operations. This question was scoped in terms of three MOEs, which were derived from the DRM and operational requirements. The three LAMP MOEs evaluated by this project were

- MOE 1: Percent of targets identified in 4 hours
- MOE 2: Time between system receipt of fire mission and target impact
- MOE 3: Percentage of targets successfully affected

In order to evaluate the various alternatives' in terms of the identified MOEs, this project developed BOE and discrete-event models for both the ISR&T data collection and fires employment phases of the amphibious raid described in the DRM. The developed models used the factors associated with each configuration (i.e., the air assets and shipboard weapon system associated with each configuration) as input, translated those factors into specific system parameters based on the constituent asset parameters (e.g., shipboard weapon system rate of fire, air asset platform speed), and evaluated the given configurations to determine the effectiveness of each in terms of the defined MOEs. The models used to evaluate the effectiveness of each feasible configuration are presented in Chapter IV.

D. WHAT WOULD THE MOST COST-EFFECTIVE LCS MISSION PACKAGE BE TO SUPPORT AMPHIBIOUS OPERATIONS?

Based upon the potential alternatives' mission effectiveness and associated cost estimates, the analysis of alternatives evaluated which configuration was the most cost-effective solution. Four feasible alternatives were ultimately identified as cost-effective solutions, ranging between LCCEs of \$105.49M and \$188.22M and providing varying levels of effectiveness in terms of average engagement time and percentage of threats successfully affected. These include Alternative 9 (MH-60 w/APKWS and no shipboard weapon), Alternative 4 (MQ-8B w/APKWS and a 76 mm gun), Alternative 10 (one MH-60R w/APKWS and a 76 mm gun), and Alternative 7 (MH-60 w/Hellfire and a 76 mm gun).

E. FUTURE WORK

While this paper considered the effectiveness of LAMP configurations in two distinct phases of an amphibious assault, a unified model that considered the relationship between the data collection and fires employment models may better characterize the effectiveness of a LAMP in AMW. A more unified approach to modeling the multiple phases of an amphibious assault may support further analysis of the necessary interfaces between the LAMP elements, and the effectiveness of the LCS seaframe in providing and supporting those interfaces.

This analysis assumed a LAMP crew of fourteen dedicated to the system elements; further work may consider the C2 functions that may be assumed by additional LAMP operations, related to both the LAMP assets and various actors within the ARG/MEU. This further work would benefit from the analysis of the LAMP element interfaces mentioned above, and may contribute to the consideration of capability gaps not presented in this report.

An analysis of the technical integration of a GMLRS or 76 mm gun with a LCS mission module may provide further insight to the technical risk associated with the evaluated LAMP configurations. The technical risk of each configuration may be

considered against the presented OMOEs and LCCEs for further characterization of the risk/reward associated with each configuration.

THIS PAGE INTENTIONALLY LEFT BLANK

APPENDIX A – USMC CAPABILITY GAP ANALYSIS

This appendix provides the list of capability gaps considered by this project in support of DRM and operational architecture development. Table 30 provides a complete list of the fire support and ISR&T capability gaps considered by this project.

Table 30 Considered Capability Gaps (after USMC 2014a; U.S. DOD 2005; U.S. DOD 2010)

MCGL RANK	GAP SOURCE	GAP TITLE	GAP DESCRIPTION
6	POM-16 MCGL	Engage direct fire targets during amphibious/mech ops	(U) The Assault Amphibian Community lacks the ability to effectively engage targets in all environments through organic direct-fire means.
8	POM-16 MCGL	Engage targets with appropriate weapons/target pairing	(U) As a result of the DOD Policy on Cluster Munitions and Unintended Harm to Civilians dated 19 June 2008, the GCE will lose its use of the 155mm Dual Purpose Improved Conventional Munitions (DPICM) projectiles. DPICM is the most effective 155mm munition in the GCE inventory against light, medium, and heavy targets and it is particularly effective against widely dispersed, inaccurately located targets.
33	POM-16 MCGL	Weapons/equipment signatures	(U) The Marine Corps has a limited ability to avoid detection of maneuver units due to individual small arms/equipment signatures as a result of equipment weight, bulk, and design; small arms/equipment signatures across the visible/IR spectrum (current gap is against SWIR); and weapons audible/visual signatures when the weapon is fired.
38	POM-16 MCGL	Conduct Distribution Operations	(U) Limited distribution capability to efficiently and effectively deliver tailored and responsive force packages and functional logistics capabilities (to include communications, engineer, transportation, and ordnance equipment) to MAGTF elements that are widely dispersed in developed and undeveloped areas with limited road access. This gap includes material handling services for medium capacity lifting to include clearing landing zones of supplies and equipment, loading and unloading combat vehicles, aircraft, and ISO containers. This gap includes the inability to manage/perform proper freight distribution while in a deployed environment to supported units/organizations. This gap also includes the inability to adequately distribute large amounts of potable water to locations away from production point.
39	POM-16 MCGL	VMU Precision Fires Capability	(U) The VMU squadrons lack the ability to precisely engage fixed, stationary, and moving surface targets via kinetic means, which adversely limits the MAGTF's ability to rapidly prosecute fleeting and/or highly-defended targets during MAGTF activities across the range of military operations.
88	POM-16 MCGL	Stop vehicles, small vessels, or aircraft (on the ground) through non-lethal means	(U) Limited ability to stop vehicles. No capability to stop small vessels and A/C (On the Ground) while minimizing casualties and limiting collateral damage.

MCGL RANK	GAP SOURCE	GAP TITLE	GAP DESCRIPTION
93	POM-16 MCGL	limited ability to disable vehicles vessels, or A/C (on the ground) through non-lethal means	(U) Limited ability to disable vehicles and A/C (On the Ground) while Minimizing casualties and limiting collateral damage.
99	POM-16 MCGL	Deficient capability to adequately provide SFA/FID forces	(U) The Marine Corps' ability to provide adequate forces to conduct SFA/FID missions in permissive and uncertain environments is deficient.
N/A	JOINT FIRES ICD	Ability to transmit and receive the required targeting information from ISR&T sources to fires command and control systems.	The critical task description is the capability to assign target-weapon pairing, provide target locations, target descriptions, and specify methods of fire. This capability requires a well-defined joint fires C2 organization, and supporting systems architecture. Within this architecture, ISR&T systems must provide accurate, precise target locations in a responsive manner and should strive to reduce the kill chain timeline through more efficient exploitation and measurement processes. From a joint targeting perspective, the various Service ISR&T programs that contribute to the Target element of the F2T2EA kill chain must be fully interoperable, interdependent and designed to seamlessly interface with the fires command and control systems – this also requires networked and knowledge empowered expeditionary joint forces. The desired capability includes a target nomination and sensor/weapon pairing to target process that provides clarity regarding the priority of, and desired effects, associated with a particular target that results in the issuance of a timely, efficient and unambiguous engagement order. This includes highly integrated and automated planning systems and processes, asset deconfliction and final target location data in a format usable by the shooter. Finally, this desired capability includes the capability to conduct counter-battery detection with in-service and future airborne, shipboard and ground-based radar systems. Achieving this desired capability as soon as practicable will enable the Commander to exploit other Service ISR&T capabilities which will significantly improve the responsiveness in passing effective targeting information to the shooting platform.
N/A	JOINT FIRES ICD	Ability to engage moving point and moving area targets under restricted weather conditions.	Conduct Joint Fire Support to achieve desired effects against moving point and moving area targets in restricted weather conditions; for example, when the sensor providing the target location to the weapon is unable to “see” the target due to poor weather conditions such as fog, low ceiling, haze, heavy rain, or blowing sand. Achieving a continuous adverse-weather/terrain fires capability as soon as practicable will enable the Commander to provide effective, agile and persistent fires to attack targets in the MCO or GWOT campaign scenarios.
N/A	JOINT FIRES ICD	Ability to engage known and / or identified targets when friendly forces are in close contact or when collateral damage is a concern.	Conduct joint fire support when the rules of engagement impose limitations on collateral damage or casualties. This desired capability requires precision, improved accuracy and scalable or reduced blast radius (or effects) engagement capabilities. Achieving this desired capability as soon as practicable will assist the Army, Marine Corps and Special Operations Forces Component Commander to maneuver and control territory, populations and fix key enemy formations in order to remove them from the fight.

MCGL RANK	GAP SOURCE	GAP TITLE	GAP DESCRIPTION
N/A	JOINT FIRES ICD	Ability to provide fires to achieve volume effects (i.e., suppression)	Joint fire support capability that is agile, flexible and capable of providing sustained amounts of fire power to support Army, Marine Corps and Special Operations Force mobile maneuver forces. The fire support capability must have sufficient capacity to deliver a large volume of fires on multiple targets simultaneously or over a short period of time, as well as the capability to deliver a high density of accurate fires in a concentrated area to rapidly achieve the desired effects.
20	POM-16 MCGL	Electronic Warfare Support	(U//FOUO) The ability to sense the Electromagnetic Operating Environment to provide strategic and tactical Electronic Warfare support information to the Marine Air-Ground Task Force commander for the purpose of coordinating Spectrum maneuver with command and control.
25	POM-16 MCGL	Direct integrated fire control engagements	(U) Addresses the Marine Corps air and ground sensors, networks, platforms, command and control (C2) and weapon systems ability to support Integrated Fire Control (IFC) engagements of enemy air threats including Precision Cue, Engagements on Remote, Engage on Composite and Forward Pass.
43	POM-16 MCGL	Persistent Ground Surveillance	(U) MAGTF has limited ability to conduct persistent ground surveillance in AOR during offensive and defensive operations both day and night.
46	POM-16 MCGL	IAMD Detect Threats	(U) Addresses MAGTF ability to classify or determine the type or model of non-cooperative aircraft and detect, identify, and track low altitude threats and non-line-of-sight targets.
78	POM-16 MCGL	Intelligence Collection	(U) Limited ability to establish persistent all-source collection against targets operating in complex terrain. This includes collection against weapons and explosives, including CBRN being employed, carried, or in caches.
N/A	UNMANNED SYSTEMS ICD	Persistent OE Surveillance	The ability to conduct persistent multi-discipline intelligence collection, near-real-time reallocation, and dynamic re-tasking of assets. This gap is an issue of both sufficiency (insufficient number of intelligence collection assets) and a lack of capability (limited sensing and endurance of assets).
N/A	UNMANNED SYSTEMS ICD	Enhance information/data distribution	Provide automated information dissemination and enhanced data distribution in support of precision direct and indirect fires and cooperative engagement.
N/A	UNMANNED SYSTEMS ICD	Near-real-time relevant information	Enhance commanders' situational awareness by providing near-real-time relevant information within a collaborative C2 environment based on federated data standards and schema, an open architecture, and common control standards.
N/A	UNMANNED SYSTEMS ICD	Increase ISR range and persistence	Increase range and endurance of ISR assets to support worldwide contingency operations

THIS PAGE INTENTIONALLY LEFT BLANK

APPENDIX B – LAMP CV-6

This appendix (Table 31) provides the matrix that documents the traceability between the capabilities assigned to the LAMP as part of the DRM and the operational activities associated with those capabilities.

Table 31 LAMP capability to operational activities mapping (CV-6)

Capability to Operational Activities Mapping	Capability Gaps															
	Fire Support	ENGAGE DIRECT FIRE TARGETS DURING AMPHIBIOUS/MECHOPS	ENGAGE TARGETS WITH APPROPRIATE WEAPONS/TARGET PAIRING	DIRECT INTEGRATED FIRE CONTROL ENGAGEMENTS	VMU PRECISION FIRES CAPABILITY	ABILITY TO ENGAGE MOVING POINT AND MOVING AREA TARGETS UNDER RESTRICTED WEATHER CONDITIONS	ABILITY TO ENGAGE KNOWN AND/OR IDENTIFIED TARGETS WHEN FRIENDLY FORCES ARE IN CLOSE CONTACT OR	ABILITY TO PROVIDE FIRES TO ACHIEVE VOLUME EFFECTS (IE: SUPPRESSION)	ISR	PERSISTENT GROUND SURVEILLANCE	INTELLIGENCE COLLECTION	ABILITY TO TRANSMIT AND RECEIVE THE REQUIRED TARGETING INFORMATION FROM ISR&T SOURCES TO FIRES	PERSISTENT OE SURVEILLANCE	ENHANCE INFORMATION/DATA DISTRIBUTION	NEAR-REAL-TIME RELEVANT INFORMATION	INCREASE ISR RANGE AND PERSISTENCE
Operational Activities																
OA 0 Provide AMW Mission Support	x								x			x				
OA 1 Deploy/Conduct Maneuver													x			x
Conduct Strike/Power Projection Warfare																
Conduct Tactical Recon and Surveillance																
Launch Aircraft																
Recover Aircraft																
Employ Remote Vehicles																
OA 2 Develop Intelligence						x				x	x					
Assess Tactical Environment																
Collect Target Information																
Establish Secure and Rapid Dissemination Means																
Disseminate and Integrate Intelligence																
Perform Tactical Recon and Surveillance																
Collect Data And Intelligence																
OA 3 Conduct Fire Support		x			x		x	x								
Illuminate/Designate Targets																
Interdict Enemy Operational Forces/Targets																
Select Target to Attack																
Engage Targets																
Attack Surface Targets																
Attack Enemy Land Targets																
Select Platforms and Systems for Attack			x													
Adjust Fires									x							
Integrate Tactical Fires																
OA 4 Perform Logistics and Combat Service Support																
Arm																
Fuel																
Repair/Maintain Equipment					x											
OA 5 Exercise Command and Control														x	x	
Manage Means of Communicating Information																
Receive and Transmit Force Orders																
Analyze and Assess Situation																
Acquire, Process, Communicate Information, and Maintain Status																
Direct, Lead, and Coordinate Forces																
Capabilities																
BATTLESPACE AWARENESS									x							
ISR										x	x		x	x	x	x
ENVIRONMENT											x					
FORCE APPLICATION	x															
MANEUVER		x	x													
ENGAGEMENT		x	x		x	x	x	x								
COMMAND AND CONTROL	x								x							
UNDERSTAND			x									x		x		
DECIDE			x										x			
DIRECT				x												
MONITOR											x				x	

THIS PAGE INTENTIONALLY LEFT BLANK

APPENDIX C – LAMP SV-5A AND SV-5B

This appendix (Tables 32, 33, and 34) provides the LAMP SV-5a and SV-5b, which documents the traceability between the LAMP operational activities and system functions (SV-5a) and system functions to system elements (SV-5b).

Table 32 LAMP operational activity to systems function traceability matrix (SV-5a) (1 of 1)

No.	Name	No.	Name
		F.0	Provide AMW Support
		F.1	Maneuver Aviation Asset
		F.1.1	Launch Aviation Asset
		F.1.2	Employ Remote Air Asset
		F.1.3	Conduct Power Projection Strike
		F.1.4	Recover Aviation Asset
		F.1.5	Conduct Tactical Recon and Surveillance
		F.2	Develop Intelligence
		F.2.1	Collect Data and Intelligence
		F.2.2	Perform Tactical Reconnaissance and Surveillance
		F.2.3	Collect Target Information
		F.2.4	Assess Tactical Environment
		F.2.5	Disseminate and Integrate Intelligence
		F.2.6	Conduct Analysis and Produce Intelligence
		F.3	Conduct Fire Support
		F.3.1	Engage Targets
		F.3.2	Interdict Enemy Operational Forces/Targets
		F.3.3	Illuminate/Designate Targets
		F.3.4	Adjust Fires
		F.3.5	Integrate Tactical Fires
		F.4	Perform Logistics
		F.4.1	Provide Logistics Demand Signal
		F.4.2	Arm/Reload
		F.4.3	Distribute Hotel/Support Resources
		F.4.4	Repair/Maintain
		F.4.5	Fuel
		F.5	Exercise Command and Control
		F.5.1	Manage Means of Communicating Information
		F.5.2	Receive and Transmit Force Orders
		F.5.3	Acquire, Maintain, and Communicate Information
		F.5.4	Select Platforms and Systems for Attack
		F.5.5	Direct and Coordinate Forces
		F.5.6	Analyze and Assess Situation
OA.0	Provide AMW Mission Support	X	
OA.1	Deploy/Conduct Maneuver	X	
OA.1.1	Conduct Strike/Power Projection Warfare		X
OA.1.2	Conduct Tactical Recon and Surveillance		X
OA.1.3	Launch Aircraft	X	
OA.1.4	Recover Aircraft		X
OA.1.5	Employ Remote Vehicles	X	
OA.2	Develop Intelligence		X
OA.2.1	Assess Tactical Environment		X
OA.2.2	Collect Target Information		X
OA.2.3	Establish Secure and Rapid Dissemination Means		X
OA.2.4	Disseminate and Integrate Intelligence	X	
OA.2.5	Perform Tactical Recon and Surveillance		X
OA.2.6	Collect Data And Intelligence	X	
OA.3	Conduct Fire Support	X	
OA.3.1	Illuminate/Designate Targets		X

Table 33 LAMP operational activity to systems function traceability matrix (SV-5a) (2 of 2)

No.	Name	No.	Name
		F.0	Provide AMW Support
		F.1	Maneuver Aviation Asset
		F.1.1	Launch Aviation Asset
		F.1.2	Employ Remote Air Asset
		F.1.3	Conduct Power Projection Strike
		F.1.4	Recover Aviation Asset
		F.1.5	Conduct Tactical Recon and Surveillance
		F.2	Develop Intelligence
		F.2.1	Collect Data and Intelligence
		F.2.2	Perform Tactical Reconnaissance and Surveillance
		F.2.3	Collect Target Information
		F.2.4	Assess Tactical Environment
		F.2.5	Disseminate and Integrate Intelligence
		F.2.6	Conduct Analysis and Produce Intelligence
		F.3	Conduct Fire Support
		F.3.1	Engage Targets
		F.3.2	Interdict Enemy Operational Forces/Targets
		F.3.3	Illuminate/Designate Targets
		F.3.4	Adjust Fires
		F.3.5	Integrate Tactical Fires
		F.4	Perform Logistics
		F.4.1	Provide Logistics Demand Signal
		F.4.2	Arm/Reload
		F.4.3	Distribute Hotel/Support Resources
		F.4.4	Repair/Maintain
		F.4.5	Fuel
		F.5	Exercise Command and Control
		F.5.1	Manage Means of Communicating Information
		F.5.2	Receive and Transmit Force Orders
		F.5.3	Acquire, Maintain, and Communicate Information
		F.5.4	Select Platforms and Systems for Attack
		F.5.5	Direct and Coordinate Forces
		F.5.6	Analyze and Assess Situation
OA.3.2	Interdict Enemy Operational Forces/Targets		
OA.3.3	Select Target to Attack		
OA.3.4	Engage Targets		
OA.3.5	Select Platforms and Systems for Attack		
OA.3.6	Adjust Fires		
OA.3.7	Integrate Tactical Fires		
OA.4	Perform Logistics and Combat Service Support		
OA.4.1	Arm		
OA.4.2	Fuel		
OA.4.3	Repair/Maintain Equipment		
OA.5	Exercise Command and Control		
OA.5.1	Manage Means of Communicating Information		
OA.5.2	Receive and Transmit Force Orders		
OA.5.3	Analyze and Assess Situation		
OA.5.4	Acquire, Process, Communicate Information, and Maintain Status		
OA.5.5	Direct, Lead, and Coordinate Forces		

Table 34 LAMP operational activity to systems traceability matrix (SV-5b)

No.	Name	No.	Name
O.0 LCS AMW MP		F.0 Provide AMW Support	
O.1	Shipboard Weapon System	F.1	Maneuver Aviation Asset
O.1.1	Weapon	F.1.1	Launch Aviation Asset
O.1.2	Dispense System	F.1.2	Employ Remote Air Asset
O.2	Air Detachment	F.1.3	Conduct Power Projection Strike
O.2.1	Air Platform	F.1.4	Recover Aviation Asset
O.2.2	Air Weapon System		Conduct Tactical Recon and Surveillance
O.2.3	Air ISR System	F.1.5	Surveillance
O.3	C2 Subsystem	F.2	Develop Intelligence
O.3.1	Fire Control	F.2.1	Collect Data and Intelligence
O.3.2	Communications Distributor		Perform Tactical Reconnaissance and Surveillance
O.3.3	Air Asset Control	F.2.2	Collect Target Information
O.3.4	Data Processor	F.2.3	Assess Tactical Environment
O.4	Support Subsystem		Disseminate and Integrate Intelligence
O.4.1	Support Distribution System	F.2.5	Conduct Analysis and Produce Intelligence
O.4.2	Status Monitor	F.2.6	Intelligence
O.4.3	Maintenance and Support System	F.3	Conduct Fire Support
		F.3.1	Engage Targets
			Interdict Enemy Operational Forces/Targets
		F.3.2	Engage Targets
			Interdict Enemy Operational Forces/Targets
		F.3.3	Engage Targets
			Interdict Enemy Operational Forces/Targets
		F.3.4	Engage Targets
			Interdict Enemy Operational Forces/Targets
		F.3.5	Engage Targets
			Interdict Enemy Operational Forces/Targets
		F.4	Perform Logistics
		F.4.1	Provide Logistics Demand Signal
		F.4.2	Arm/Reload
		F.4.3	Distribute Hotel/Support Resources
		F.4.4	Repair/Maintain
		F.4.5	Fuel
		F.5	Exercise Command and Control
			Manage Means of Communicating Information
		F.5.1	Receive and Transmit Force Orders
			Acquire, Maintain, and Communicate Information
		F.5.2	Receive and Transmit Force Orders
			Acquire, Maintain, and Communicate Information
		F.5.3	Receive and Transmit Force Orders
			Acquire, Maintain, and Communicate Information
		F.5.4	Attack
			Select Platforms and Systems for Attack
		F.5.5	Direct and Coordinate Forces
			Analyze and Assess Situation
		F.5.6	Analyze and Assess Situation
			Analyze and Assess Situation

APPENDIX D – MODELS

Figures 42 through 47 provide screen captures of the ExtendSim 8 discrete-event models used to evaluate the effectiveness of the various potential LAMP configurations, as discussed in Chapter IV.

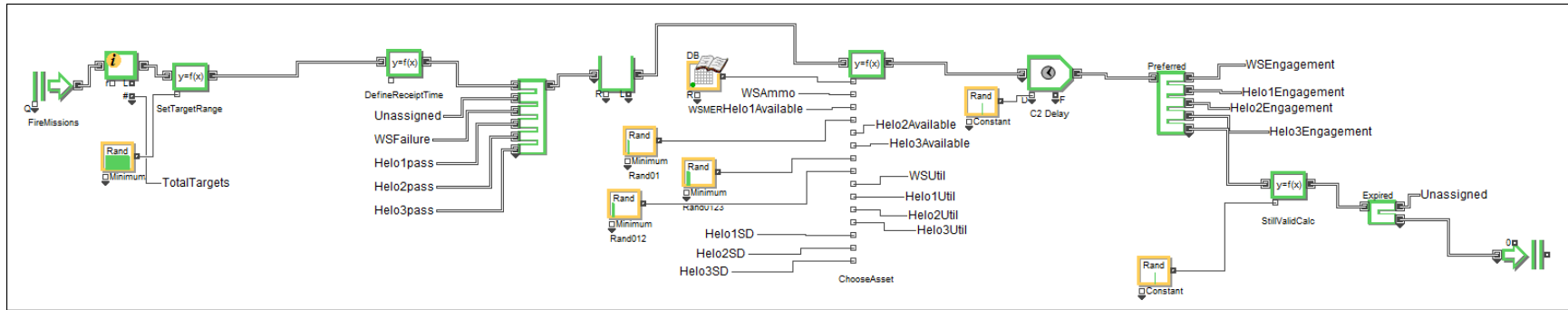

Figure 42 LAMP ISR Discrete-Event Model Snapshot

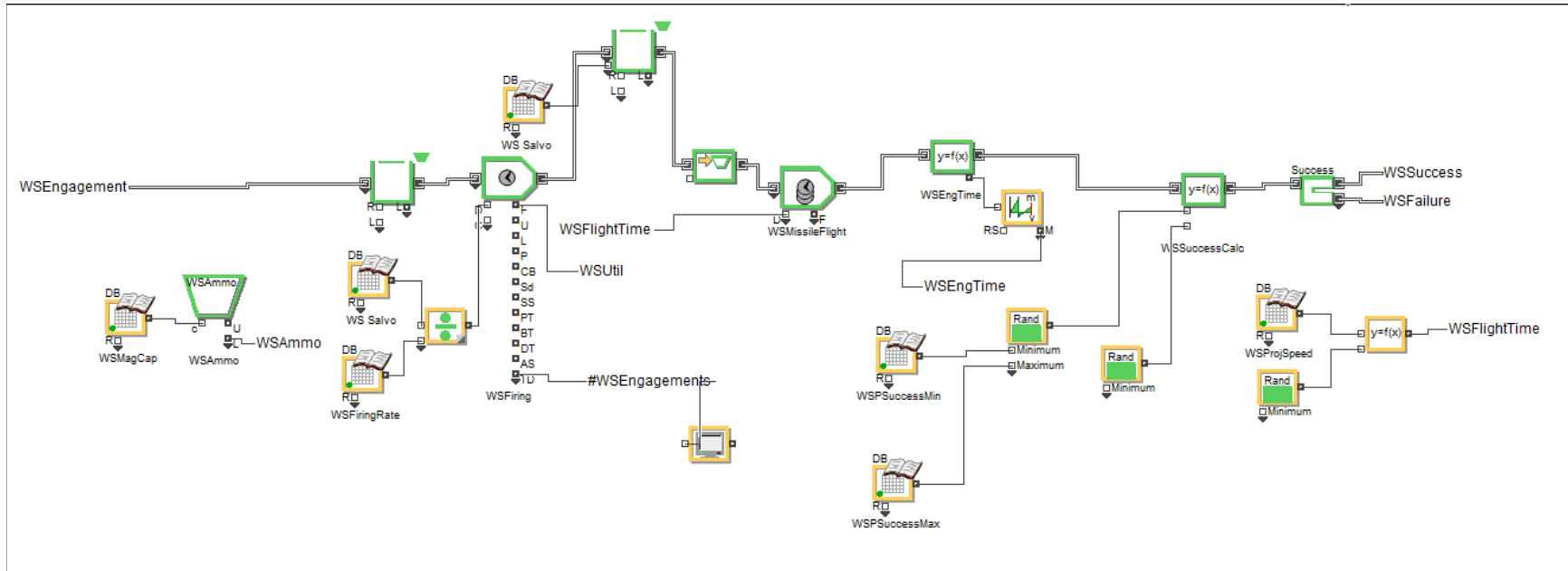

Figure 43 LAMP Shooter Discrete-Event Model Snapshot (part 1 of 5)

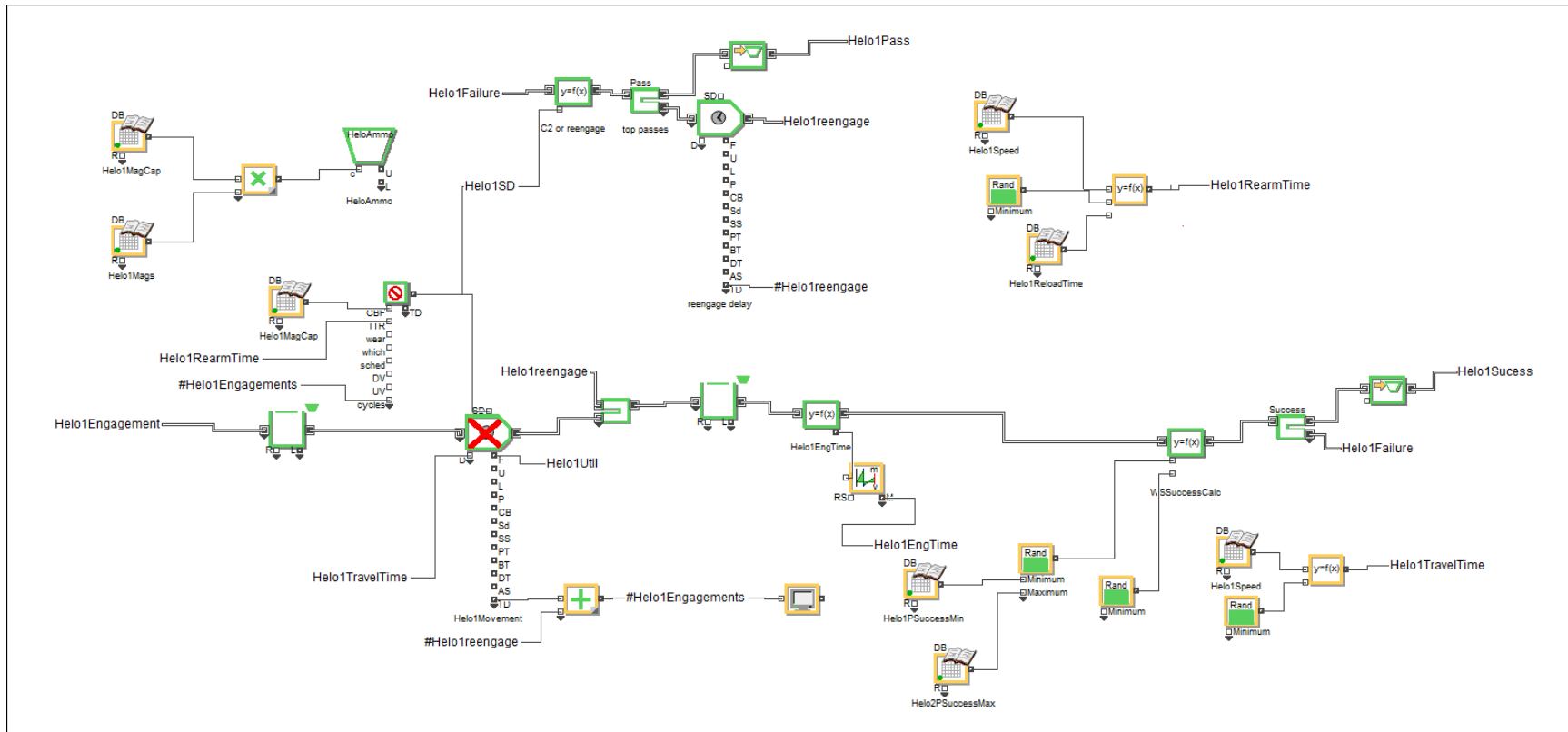

Figure 44 LAMP Shooter Discrete-Event Model Snapshot (part 2 of 5)

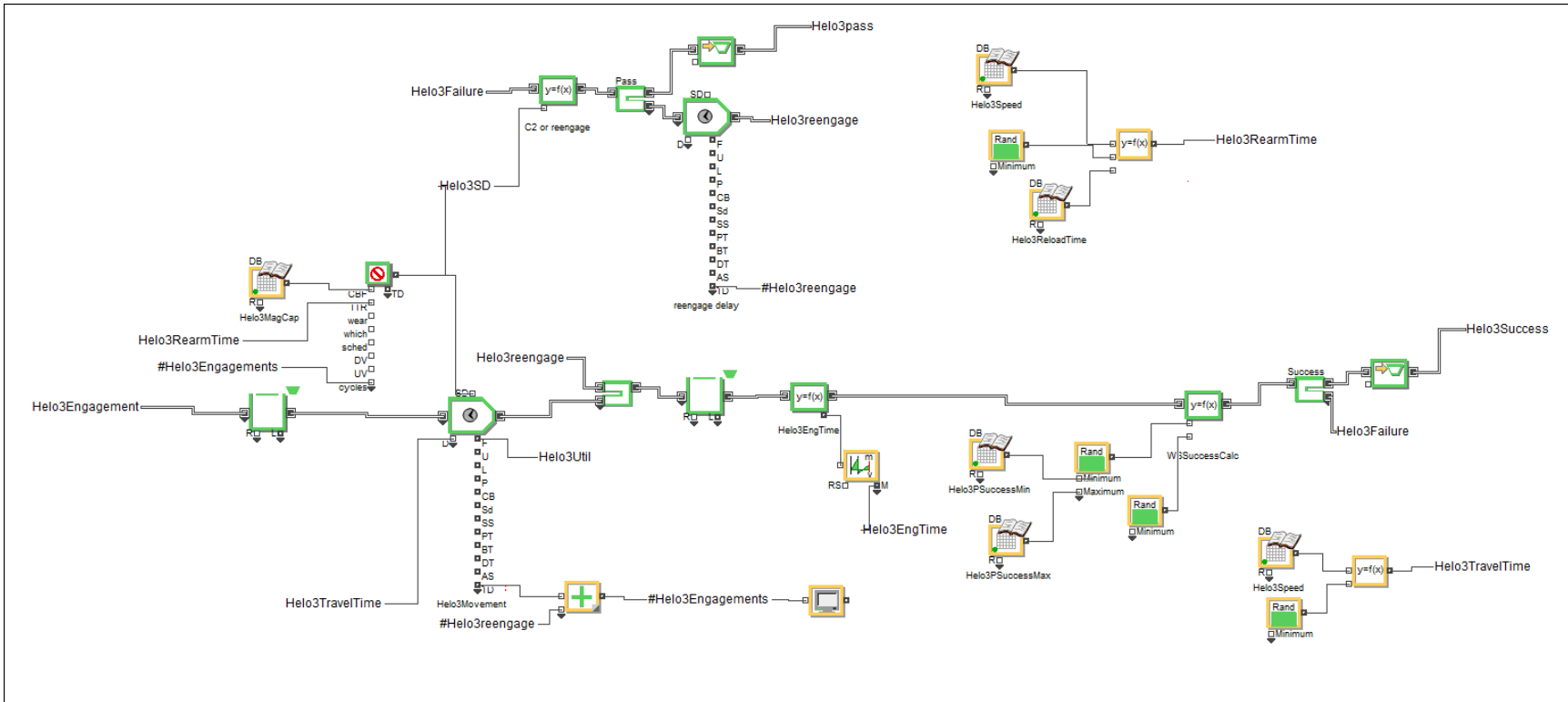

Figure 46 LAMP Shooter Discrete-Event Model Snapshot (part 4 of 5)

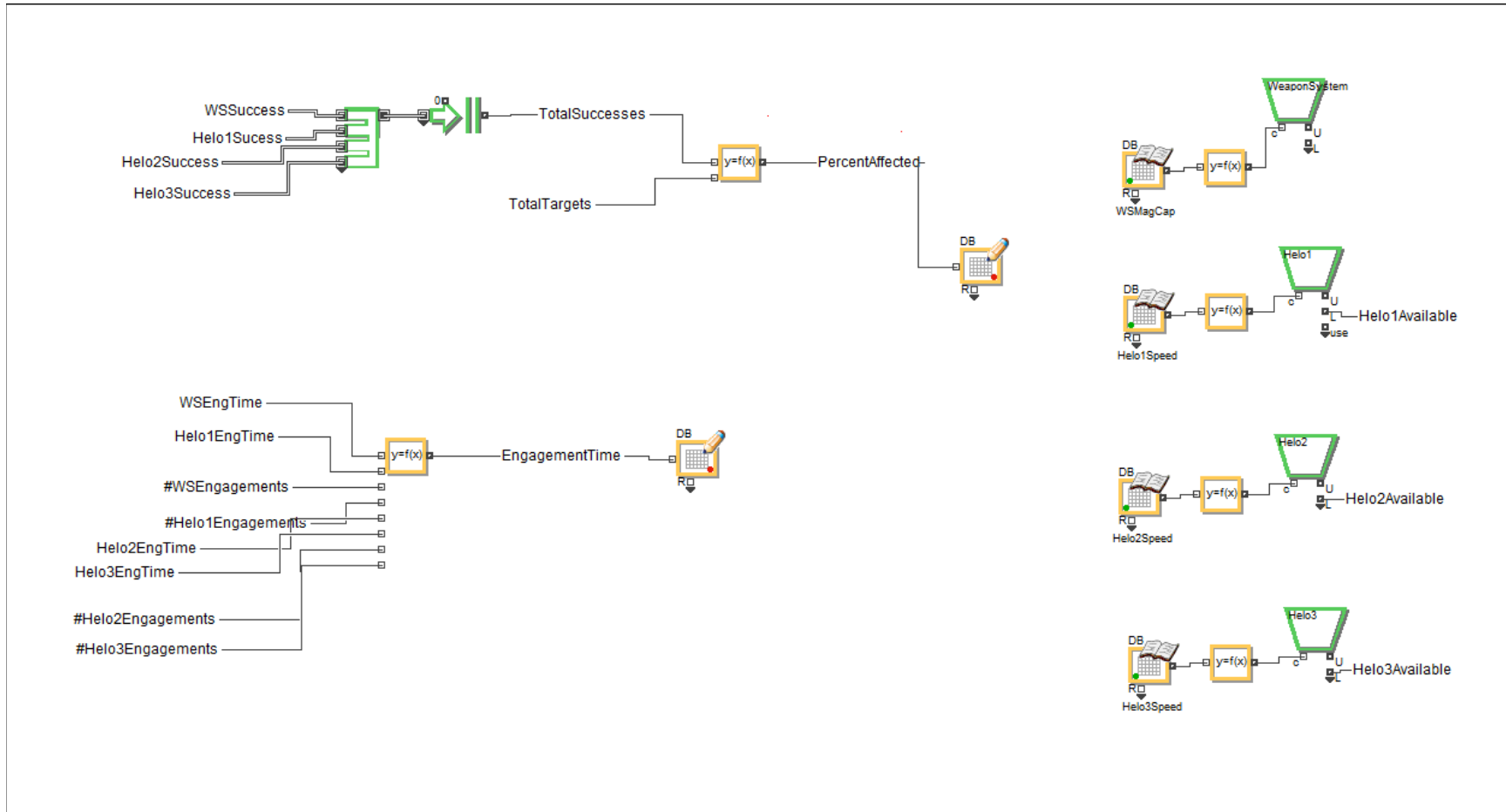

Figure 47 LAMP Shooter Discrete-Event Model Snapshot (part 5 of 5)

THIS PAGE INTENTIONALLY LEFT BLANK

LIST OF REFERENCES

- Ailes, John W. 2014, February 20. "PMS 420 Littoral Combat Ship Mission Modules." Brief presented at the annual American Society of Naval Engineers Day, Arlington, Virginia.
- Blanchard, B. 2008. *System Engineering Management*. 4th ed. New Jersey: Wiley.
- Blanchard, B. and Fabrycky, W. 2011. *Systems Engineering and Analysis*. 5th ed. New Jersey: Pearson Prentice Hall.
- Chew, LCT Fredrick. "Reflections on Operation Blue Orchid (Sea)." *POINTER: Journal of the Singapore Armed Forces*, vol. 34 no. 2 (2008): 14–26.
- The Ellis Group. 2012, August 27. "United States Amphibious Forces: Indispensable Elements of American Seapower." *Small Wars Journal*.
<http://smallwarsjournal.com/jrnl/art/us-amphibious-forces-indispensible-elements-of-american-seapower>.
- FLIR Systems, Inc. 2010. "Brite Star II." http://gs.flir.com/uploads/file/products/brochures/brite_star_II_m_a4.pdf.
- Giammarco, Kristin. 2010, March 17–19. "Formal methods for architecture model assessment in systems engineering." Paper presented at the 8th Annual Conference on Systems Engineering Research, Hoboken, New Jersey.
- Graham, MAJ Jeff. 2004, June 14–16. "Marine Representative to the Naval Surface Fire Support Program Office Brief for the National Defense Industrial Association International Armaments Technology Symposium and Exhibition." Brief presented at the NDIA International Armaments Technology Symposium and Exhibition, Parsippany, New Jersey.
- Hutchins, Susan G., William G. Kemple, David L. Kleinman, and Susan P. Hocevar. 2005, June 13–16. "Expeditionary Strike Group: Command Structure Design Support." Paper presented at the 10th International Command and Control Research & Technology Symposium, Washington, D.C.
- Jacobson, Kevin R. 2010. "The Littoral Combat Ship Surface Warfare Module: Determining the Surface-To-Surface Missile and Air-To-Surface Missile Mix." Master's thesis, Naval Postgraduate School.
- Jones, Corey. 2014, July 18. "Special Operations Forces, USS Independence Train during Rim of the Pacific 2014," *Navy News Service*. http://www.navy.mil/submit/display.asp?story_id=82309.

- Lockheed Martin. "Target Sight System – Lockheed Martin." Last modified July 12, 2014. <http://www.lockheedmartin.com/us/products/TSS.html>.
- . "Lockheed Martin's Multi-mission Combat Ship: Proven, Low-Risk Capability," no date. http://www.lmlcsteam.com/wpcontent/uploads/2013/05/MCS_Bifold.pdf.
- Miller, Lieutenant Kyle, Lieutenant Junior Grade Vasilis Georgiadis, and Ensign Alexandar Laun. 2013 "Feasibility Assessment of a Naval Surface Fire Support Capability for the Mono-Hull Variant of the Littoral Combat Ship." Master's thesis, Massachusetts Institute of Technology.
- Oestergaard, Joakin K. 2014(a), July 31. "Aerospace and Defense Intelligence Report: M142 HIMARS," for Aeroweb. <http://www.bga-aeroweb.com/Defense/HIMARS.html>.
- . 2014(b), June 6. "Aerospace and Defense Intelligence Report: Bell AH-1Z," for Aeroweb. <http://www.bga-aeroweb.com/Defense/AH-1Z-Viper.html>.
- . 2014(c), June 6. "Aerospace and Defense Intelligence Report: MQ-8B Firescout," for Aeroweb. <http://www.bga-aeroweb.com/Defense/MQ-8B-Firescout.html>.
- O'Rourke, Ronald. 2011. *Navy Littoral Combat Ship Program: Background and Issues for Congress*. Washington, DC: Congressional Research Service.
- Pincoski, Lieutenant Colonel Mark. 2008, April 15. "Precision Guided Missiles and Rockets Program Review." Brief presented at the Precision Strike Annual Programs Review, Huntsville, Alabama.
- Polmar, Norman. 2005. *The Naval Institute Guide to the Ships and Aircraft of the United States Fleet*. Annapolis: United States Naval Institute.
- Raytheon Company. 2014(a). "Raytheon Company: AN/AAS-44C(V) Multi-Spectral Targeting System." Accessed on July 5. <http://www.raytheon.com/capabilities/products/aas44c/>.
- . 2014(b). "Raytheon Company: ATFLIR – The Future is Now." Accessed on July 12. <http://www.raytheon.com/capabilities/products/atflir/>.
- Riccio, Colonel Marc F. 2013, May 13. "Exercise Bold Alligator 2013 (BA 13): A Return to our Amphibious Roots." <http://www.afcea.org/events/jwc/13/documents/BOLDALLIGATOR13AFCEABriefv313May13Riccio.pdf>.

- Schoenster, Bill and Ken Michaud. 2008, November 6. "Littoral Combat Ship Program Overview." http://www.ndia.org/Divisions/Divisions/International/Documents/International_LCS_Program_Overview.pdf.
- Sikorsky. "SEAHAWK® Helicopter." Accessed July 5, 2014. <http://www.sikorsky.com/Products/Product+Details/Model+Family+Details?mofid=4a1bebb600e98110VgnVCM1000001382000a&provcmid=bfa955f4a9d98110VgnVCM1000001382000aRCRD&mofvcmid=5a1bebb600e98110VgnVCM1000001382000aRCRD>.
- Surmeir, John J. 1969. "Alternative Approaches to Using Peacetime and Wartime Costs in Limited War Cost-Effectiveness Studies." Santa Monica: RAND Corporation.
- Telephonics. no date(a). "AN/APS-153(V) Multi-Mode Radar." <http://www.telephonics.com/pdf/AN-APS-153V.pdf>.
- . no date(b). "RDR-1700B." <http://www.telephonics.com/pdf/33383RDR-1700B.pdf>.
- U.S. Army. 2014(a). "Precision Fires Rocket and Missile System Munitions (PGM/R)." Accessed June 2. <http://www.msl.army.mil/Pages/PFRMS/pgmr.html>.
- . 2014(b). "Operating and Support Management Information System." Accessed on July 17. <https://www.osmisweb.army.mil/>.
- . 2013, April. "Department of Defense Fiscal Year (FY) 2014 President's Budget Submission: Missile Procurement, Army." Washington, DC: Army Financial Management.
- U.S. DOD. 2014(b). "Aerospace and Defense Intelligence Report: M142 HIMARS." <http://www.bga-aeroweb.com/Defense/HIMARS.html>.
- . 2014(a). *Joint Publication 1-02: Department of Defense Dictionary of Military and Associated Terms*.
- . 2013, May 9. "FY 2014 Department of Defense (DOD) Military Personnel Composite Standard Pay and Reimbursement Rates." http://comptroller.defense.gov/Portals/45/documents/rates/fy2014/2014_k.pdf.
- . 2012, December 31. "Selected Acquisition Report: Littoral Combat Ship," RCS: DD-A&T(Q&A)823-374.
- . 2011, April 8. "Joint Capability Areas; Joint Capability Areas 2010 Refinement." http://www.dtic.mil/futurejointwarfare/strategic/jca_framework_defs.doc.

- . 2010, May 14. “Initial Capabilities Document for Unmanned Systems (Air, Ground, and Maritime),” Draft Version 2.2.
- . 2009, July 18. *Joint Publication 3–02: Amphibious Operations*.
- . 2005, November 1. “Initial Capabilities Document for Joint Fires in Support of Expeditionary Operations in the Littorals,” Version 1.2.
- USMC. 2014(a). “Program Objective Memorandum-16 Marine Corps Gaps List.”
- . 2014(b), March 4. *Expeditionary Force 21: Forward and Ready: Now and in the Future*. http://www.mccdc.marines.mil/Portals/172/Docs/MCCDC/EF21/EF21_USMC_Capstone_Concept.pdf.
- . 2012, April 27. “Naval Amphibious Capability in the 21st Century: Strategic Opportunity and a Vision for Change.” Report prepared by the Amphibious Capabilities Working Group.
- . no date. “Amphibious Ready Group and Marine Expeditionary Unit Overview.”
- U.S. Navy. 2014(a). “AH-1Z.” Accessed June 3. <http://www.navair.navy.mil/index.cfm?fuseaction=home.displayPlatform&key=B91F9D6E-E6AE-4F98-8BC5-A46CAE6C2381>.
- . 2014(b). “MH-60R Seahawk.” Accessed June 3. <http://www.navair.navy.mil/index.cfm?fuseaction=home.displayPlatform&key=230E736F-D36A-4FB8-BDD3-372CD723D22C>.
- . 2014(c). “MQ-8B Fire Scout.” Accessed June 2. <http://www.navair.navy.mil/index.cfm?fuseaction=home.display&key=8250AFBA-DF2B-4999-9EF3-0B0E46144D03>.
- . 2014(d). “Visibility and Management of Operating and Support Costs.” Accessed on July 14. <https://www.vamosc.navy.mil/>.
- . 2014(e), March. “Department of Defense Fiscal Year (FY) 2015 Budget Estimations: Other Procurements.” http://www.finance.hq.navy.mil/FMB/15pres/OPN_BA1_BOOK.pdf.
- . 2014(f). “Department of Defense Fiscal Year (FY) 2015 Budget Estimations: Aircraft Procurement.”
- . 2014(g). “Department of Defense Fiscal Year (FY) 2015 Budget Estimations: Procurement of Ammo.”
- . 2014(h). “Department of Defense Fiscal Year (FY) 2015 Budget Estimations: Weapons Procurement.”

- . 2013(a). “The United States Navy — Fact File: MK 75 - 76 mm/62 Caliber Gun.” Last updated November 15. http://www.navy.mil/navydata/fact_display.asp?cid=2100&tid=600&ct=2.
- . 2013(b). “The United States Navy -- Fact File: MK 45 – 5-inch-gun54/62 Caliber Guns.” Last updated November 25. http://www.navy.mil/navydata/fact_display.asp?cid=2100&tid=575&ct=2.
- . 2012, April 17. “Marine Helicopters Deploy with Laser-Guided Rocket.” *NAVAIR News*. <http://www.navair.navy.mil/index.cfm?fuseaction=home.NavairNewsStory&id=4972>.
- . 2011(a), July 29. “Department of the Navy Architecture Development Guide Version 2.0.”
- . 2011(b), June 8. “Justification and Approval For Use of Other Than Full and Open Competition,” J&A No.: 54,016. https://www.neco.navy.mil/synopsis_file/N00024-11-C-5453~N00024~54016~NECO.pdf.
- . 2009. “The United States Navy -- Fact File: AGM-114B/K/M Hellfire Missile.” Last updated February 20. http://www.navy.mil/navydata/fact_display.asp?cid=2200&tid=400&ct=2.
- . 2005. “The Amphibious Readiness Group.” Last modified June 17. <http://www.navy.mil/navydata/news/.www/arg.html>.
- . 2004, December 6. *Littoral Combat Ship Concept of Operations*.
- . n.d. “Mine Counter-Measures Mission Package.”
- U.S. Navy, USMC, and USCG. 2007, January 30. “Universal Naval Task List,” OPNAVINST 3500.38B/MCO 3500.26A/USCG COMDTINST M3500.1B.
- . 2010. “Naval Operations Concept 2010: Implementing the Maritime Strategy.” <http://www.navy.mil/maritime/noc/NOC2010.pdf>.
- Wilke, Tim. 2014, January 10. “United States Marine Corps Integration with Freedom-Variant Mission Modules.” San Diego, CA: Littoral Combat Ship Crew 102.

THIS PAGE INTENTIONALLY LEFT BLANK

INITIAL DISTRIBUTION LIST

1. Defense Technical Information Center
Ft. Belvoir, Virginia
2. Dudley Knox Library
Naval Postgraduate School
Monterey, California