

REPORT DOCUMENTATION PAGE

Form Approved
OMB No. 0704-0188

The public reporting burden for this collection of information is estimated to average 1 hour per response, including the time for reviewing instructions, searching existing data sources, gathering and maintaining the data needed, and completing and reviewing the collection of information. Send comments regarding this burden estimate or any other aspect of this collection of information, including suggestions for reducing this burden, to Department of Defense, Washington Headquarters Services, Directorate for Information on Operations and Reports (0704-0188), 1215 Jefferson Davis Highway, Suite 1204, Arlington, VA 22202-4302. Respondents should be aware that notwithstanding any other provision of law, no person shall be subject to any penalty for failing to comply with a collection of information if it does not display a currently valid OMB control number.
PLEASE DO NOT RETURN YOUR FORM TO THE ABOVE ADDRESS.

1. REPORT DATE (DD-MM-YYYY) 06-07-2015			2. REPORT TYPE Final		3. DATES COVERED (From - To)	
4. TITLE AND SUBTITLE Test Operations Procedure (TOP) 01-2-624 High Power Microwave (HPM) Testing				5a. CONTRACT NUMBER		
				5b. GRANT NUMBER		
				5c. PROGRAM ELEMENT NUMBER		
6. AUTHORS				5d. PROJECT NUMBER		
				5e. TASK NUMBER		
				5f. WORK UNIT NUMBER		
7. PERFORMING ORGANIZATION NAME(S) AND ADDRESS(ES) Survivability, Vulnerability & Assessment Directorate (TEDT-WSV-ED) U.S. Army White Sands Missile Range White Sands Missile Range, NM 88002-5178				8. PERFORMING ORGANIZATION REPORT NUMBER TOP 01-2-624		
9. SPONSORING/MONITORING AGENCY NAME(S) AND ADDRESS(ES) Range Infrastructure Division (CSTE-TM) U.S. Army Test and Evaluation Command 2202 Aberdeen Boulevard Aberdeen Proving Ground, MD 21005-5001				10. SPONSOR/MONITOR'S ACRONYM(S)		
				11. SPONSOR/MONITOR'S REPORT NUMBER(S) Same as item 8		
12. DISTRIBUTION/AVAILABILITY STATEMENT Distribution Statement A. Approved for public release; distribution is unlimited.						
13. SUPPLEMENTARY NOTES Defense Technical Information Center (DTIC), AD No.:						
14. ABSTRACT This Test Operations Procedure (TOP) provides guidance in preparing and conducting High Power Microwave (HPM) testing and verification of Army and/or Department of Defense systems both new and modified. This document adheres to requirements stated in Military Standard (MIL-STD)-464C "Electromagnetic Environmental Effects Requirement for Systems".						
15. SUBJECT TERMS High Power Microwave Electromagnetic Radio Frequency						
16. SECURITY CLASSIFICATION OF:			17. LIMITATION OF ABSTRACT SAR	18. NUMBER OF PAGES 53	19a. NAME OF RESPONSIBLE PERSON	
a. REPORT Unclassified	b. ABSTRACT Unclassified	c. THIS PAGE Unclassified			19b. TELEPHONE NUMBER (include area code)	

(This page is intentionally blank.)

U.S. ARMY TEST AND EVALUATION COMMAND
TEST OPERATIONS PROCEDURE

*Test Operations Procedure 01-2-624
DTIC AD No.

6 July 2015

HIGH POWER MICROWAVE TESTING

		<u>Page</u>
Paragraph	1. SCOPE.....	2
	2. FACILITY AND INSTRUMENTATION	2
	2.1 Facility	2
	2.2 Instrumentation.....	3
	2.3 Data Acquisition.....	4
	3. REQUIRED TEST CONDITIONS.....	5
	3.1 Test Preparation.....	5
	3.2 Test Execution.....	8
	4. TEST PROCEDURES.....	9
	4.1 Test Setup	9
	4.2 Test Requirements.....	10
	4.3 Test Procedure.....	10
	5. DATA REQUIRED.....	12
	6. PRESENTATION OF DATA	12
	6.1 Data Analysis.....	12
	6.2 Data Presentation.....	12
	APPENDIX	A. DATA PROCESSING ALGORITHMS
B. HPM TEST PLAN		B-1
C. CALIBRATION PROCEDURES.....		C-1
D. GLOSSARY		D-1
E. ABBREVIATIONS.....		E-1
F. REFERENCES.....		F-1
G. APPROVAL AUTHORITY.....		G-1

1. SCOPE.

a. High Power Microwave (HPM) testing uses a microwave simulator to create a radio frequency (RF) environment emitting high power or high energy. The simulator may produce a single pulse, repetitive pulses, or continuous waves to generate the desired test environment. The purpose of HPM testing is to examine the response of platforms to known HPM environments and identify any vulnerability. HPM testing will ensure that operationally effective, suitable, and survivable systems are delivered to the end user. Realistic test configurations and scenarios are tested and analyzed to achieve an accurate and complete survivability test and assessment.

b. This Test Operations Procedure (TOP) provides test analysis and verification methodologies for HPM testing as conducted at the White Sands Missile Range (WSMR) HPM Test Site. This document will give a general outline of test procedures used to examine the response of platforms when introduced to known HPM environments. A description of the test data analysis will be given and will include calculations used to process data obtained.

c. This TOP adheres to Military Standard (MIL-STD) 464C^{1**} guidelines for HPM testing. This document applies to test and verification of both narrowband and wideband HPM testing environments. HPM testing is applicable for Army and/or Department of Defense (DOD) equipment testing of a complete system and platform, both new and modified, and can be adapted to suit subsystem and piece part testing requirements. HPM testing will result in timely, reliable, and consistent data to aid in determining if the system or subsystem's operational performance requirements are met.

d. The overall goal of this TOP is to provide a procedure for effective, timely, and conclusive HPM testing. This document is to be used by facility operators and test officers (TOs) for test planning, test conducting, data acquisition, and data analysis guidelines. The test procedures discussed in this document are a general outline and may be altered to accommodate each unique test.

2. FACILITY AND INSTRUMENTATION.

2.1 Facility.

a. HPM testing will aid in analysis of the response and/or susceptibility of a test article to a simulated RF environment produced by microwave simulators. HPM testing is intended to disrupt and/or damage electronic systems and may be conducted in an open field or anechoic chamber.

b. The test facility should offer an open field test area or anechoic chamber large enough to accommodate the test asset in all of its configurations. The test facility should have a dedicated staff of highly competent simulator operators, data acquisition personnel, and a photographer onsite to support customer testing.

** Superscript numbers correspond to Appendix F, References.

c. The HPM Test Facility should be capable of providing support for narrowband and wideband threat simulator testing. The test site should provide testing services with high peak powers, variable pulse widths and variable pulse repetition rates.

d. The HPM Test Site should provide a safe testing environment for all personnel present during testing. HPM testing requirements as stated in MIL-STD-464C for both narrowband and wideband simulations are displayed on Tables 1 and 2, respectively.

TABLE 1. NARROWBAND HPM INTENSITY

FREQUENCY RANGE (MHz)	ELECTRIC FIELD REQUIREMENT (kV/m @ 1km)
2000-2700	18.0
3600-4000	22.0
4000-5400	35.0
8500-11000	69.0
14000-18000	12.0
28000-40000	7.5

TABLE 2. WIDEBAND HPM INTENSITY

FREQUENCY RANGE (MHz)	BROAD-BAND ELECTRIC FIELD DISTRIBUTION REQUIREMENT (mV/m/MHz @100m)
30-150	33000
150-225	7000
225-400	7000
400-700	1330
700-790	1140
790-1000	1050
1000-2000	840
2000-2700	240
2700-3000	80

2.2 Instrumentation.

a. The data acquisition system used at the HPM Test Facility should be capable of reading, recording and processing narrowband and wideband data. Measurements of each pulse simulation should be monitored by a B-dot probe (measures the time rate of change in the magnetic field (H-Field)), D-dot probe (measures the time rate of change in the electric field (E-

Field)), open-ended waveguide, standard gain horn, and/or current probe. The magnitude of the measured pulse shape, H-Field and/or E-Field, should be recorded, analyzed and saved. All data obtained during field characterization and testing should be stored into a database on the data acquisition server. Instrumentation used during testing should be listed in the data files provided and includes equipment serial number and calibration dates. Figures 1 and 2 illustrate configurations for fiber optic links and coaxial cable, respectively.

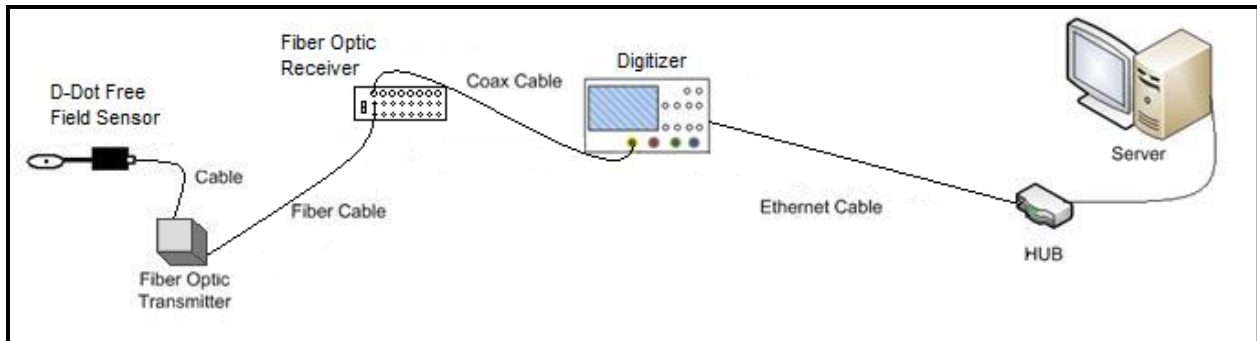

Figure 1. Fiber optic field monitoring configuration.

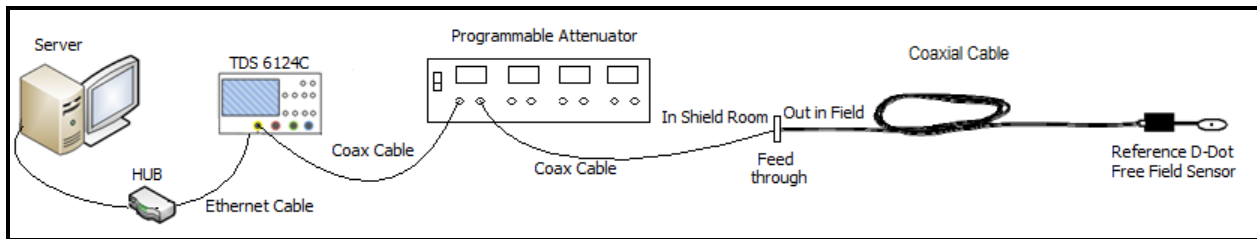

Figure 2. Coaxial cable field monitoring configuration.

b. All probes used should be characterized to insure the equipment is within specified performance tolerances. Characterization must be performed to ensure correct metrics (e.g., E-Field levels, voltage, current, etc.) are being accurately measured and the variance between pulses can be established for post test analysis. All test equipment used to monitor measurements should be calibrated annually by a calibration lab using procedures traceable to the National Institute of Standards and Technology (NIST).

c. Facility personnel will perform calibration on all instrumentation utilized for the test to ensure accurate data acquisition is accomplished. The data acquisition system corrects for loss on the instrumentation chain using the recorded calibration files.

2.3 Data Acquisition.

a. Data processing algorithms used include pulse extraction, unfolding of instrumentation effects, integration, diode detection, and down-conversion. Pulse extraction, pulse detection, and clipping algorithms are used in all measurements. Integration is used in cases when differential electromagnetic (EM) field probes measure the field. Generalized unfolding of instrumentation

effects is used in all cases for the parts of the instrumentation chain where the signal spectrum of the transmitted signal is known. For diode detection and down-conversion, a fixed frequency for the signal before the diode detector or the mixer must be set in order to calculate the signal measured at the antenna and transmitted to the diode detector or mixer.

b. Data processing starts at the oscilloscope and removes the effects of the signal conditioners in the instrumentation chain working towards the measurement probe or antenna. A single pulse or pulsed continuous wave signal is detected as significantly above the noise floor, extracted, and tightly clipped to exclude times when only noise is present. Next, the effects of signal conditioners back to the probe, diode detector, or mixer are removed from the measurements using the full scattering matrix parameterization of each signal conditioner. Then, the measurements are corrected for any diode detector or mixer effects and the signal present at the antenna or probe is determined using a single fixed frequency to represent the signal. Finally, the measurements are integrated if a differential probe collected the EM field data. The final conversion from transmitted voltages to measured EM field at the probe or antenna is done using the calibrated antenna factor of the antenna or probe. All collected data are processed using the algorithms discussed in the “Directed Energy Test and Evaluation Capability Sensor Suite Software Algorithm Manual”². Algorithms used in data processing may be found in Appendix A.

3. REQUIRED TEST CONDITIONS.

3.1 Test Preparation.

3.1.1 Scope of Testing.

The TO conducting HPM testing must be thoroughly familiar with MIL-STD-464C. Prior to testing, the TO must establish objectives that must be accomplished throughout the mission and meet MIL-STD-464C requirements. The TO must thoroughly understand test criteria, facility limitations, operational procedures, instrumentation, system integration and safety considerations to develop a realistic test schedule. The TO must reserve facility test time and provide a test plan before the test. The TO must also verify the facility is capable of accommodating the test article and any classified information. In addition, any special safety procedures to be followed for the duration of the test should be established beforehand.

3.1.2 Test Plan.

An example test plan for the WSMR HPM Test Facility may be found in Appendix B. When scheduling facility time, a test plan must be submitted. It is critical that the test plan is filled out in its entirety to provide the facility personnel with the necessary information and time to prepare for the upcoming mission. The test plan must be developed by the TO and provided to the facility operators approximately two weeks prior to test execution. Failure to provide a test plan may delay testing. Test plans should contain the following information:

a. Project Information.

6 July 2015

- b. Visitor Information.
- c. Test Article Information.
- d. Media Requirements.
- e. Test Equipment Setup.
- f. Test Specifications.

3.1.2.1 Project Information.

The TO must provide the project name, the U.S. Army Test and Evaluation Command Decision Support System (ADSS) number, and the Work-Breakdown Structure (WBS) number. These items will be used for facility usage reports. The project name will also be used to create a database for the test, unless requested otherwise. Start date, end date, and estimated overtime hours will help management arrange for after hour personnel support. The TO will include his/her contact information, test platform, and project security classification. Arrangements for classified article storage will be addressed before the scheduled test date. If any questions or concerns arise prior to the scheduled test date the facility operators will contact the TO.

3.1.2.2 Visitor Information.

The TO is asked to provide information for all visitors who will be present at the facility during testing. It will be the TO's responsibility to schedule radiation training and obtain appropriate dosimetry for all visitors that will be present at the HPM Test Facility before testing commences.

3.1.2.3 Test Article Information.

The TO shall provide the facility operators with the dimensions and weight of the test article. This information will be taken into consideration when the facility is prepared for the upcoming test. The TO must also inform the operators of the desired field intensity above ground distance and if any power requirements are needed. If additional support is needed (i.e., forklift, overhead crane, etc.) it should be included in this area as well. Informing the facility operators of additional support before a test will allow the operators to make the necessary arrangements to obtain the support needed for the scheduled test dates. The TO may also make his/her own arrangements for any additional support needed.

3.1.2.4 Media Requirements.

The TO must request media requirements such as pictures or video. Therefore properly licensed personnel may be scheduled to be present during testing. Failure to notify the facility operators of media requirements may result in the facility not being able to provide support.

3.1.2.5 Test Equipment Setup.

To help the facility operators prepare instrumentation needed for the upcoming test the number of field probes and current probes must be specified. If specific locations are requested the TO must include this in the test plan. If there are no instructions as to where the test article must be located, the test article will be placed at bore sight of the simulator at the distance needed to meet the field intensity requirements.

3.1.2.6 Test Specifications.

The TO will provide the facility with specific frequencies, field intensity levels, and polarizations needed for testing. This information will specify which systems will be used for the test and any required maintenance and/or polarization changes to the system may be completed before the scheduled test date. If both polarizations will be needed for testing the facility operators will need at minimum three hours, or a maximum of one day, to perform polarization changes during testing. This may take longer or shorter depending on the number of waveguides to be changed and if any issues arise during the polarization change.

3.1.3 Pretest Setup.

The facility operators will typically perform the following tasks prior to the test mission:

- a. Request and obtain RF authorization approval from WSMR Area Frequency Coordinator to operate during a specific timeframe.
- b. Perform any needed maintenance or polarization changes on source(s) to be used during testing.
- c. Configure the instrumentation requested on the test plan.
- d. Instrumentation calibration will be performed on all test equipment to be used during testing. Calibration procedures may be found in Appendix C.
- e. Compute the range between the test article and source at which the expected incident field will be replicated.
- f. Perform a pre-mission field characterization, along the centerline perpendicular to the output antenna, for each simulator to be used during testing. The facility operators will measure the incident electromagnetic field at the calculated distance and adjust the range between the test point and simulator, if needed, to replicate the desired environment.
- g. Verify instrumentation hardware is working properly and make any necessary changes.
- h. Any software development, fabrication, and purchases needed to perform and/or support testing will be completed at this time.

3.1.4 Personnel Exposure Policy and Guidance.

a. The DOD policy for the protection of personnel from electromagnetic fields, 0 Hz to 300 GHz, is found in the latest Department of Defense Instruction (DODI) 6055.11³. Prior to the start of test, the TO should provide RF safety awareness training/briefings to all personnel present during testing in compliance with DODI 6055.11. During all phases of testing, ensure that compliance with applicable exposure limits are strictly enforced and that appropriate RF safety program elements are in place such as blocking off access to restricted areas. The specific exposure limits used to protect personnel from hazardous RF electromagnetic fields are defined in the most current Institute of Electrical and Electronics Engineers (IEEE) standards C95.1-2005⁴ and C95.1-2345⁵. Compliance should be verified by test and/or analysis.

b. The Permissible Exposure Limits (PEL) of DODI 6055.11 will be strictly adhered to during the test. Prior to the start of the test, the operators shall verify that all personnel are aware of the safety aspects associated with radiated fields and that all personnel have been briefed on this subject.

3.2 Test Execution.

3.2.1 Pretest Analysis.

a. The TO will perform the following tasks:

(1) Thoroughly examine the test article and verify it is not damaged and is operating properly. The test article must be fully operational before exposure to the HPM environment.

(2) Note test article orientation, configuration, and position.

(3) Note and determine if instrumentation setup is acceptable and meets requirements.

(4) Note and determine if test location and field intensities are acceptable and meet requirements.

(5) Note and determine if test article setup is appropriate and meets requirements.

b. If any system configurations are not acceptable, the facility operators will make the necessary changes.

3.2.2 Test Organization.

a. A minimum of two facility operators must be present at all times during testing. The facility manager will arrange facility operator support using the work schedule provided by the TO. All visitors to the facility must be accounted for and must obey and abide by all safety protocol and mechanisms. The TO will make arrangements with Health Physics to get all visitors issued dosimetry badge and obtain the radiation briefing. All personnel present at the

HPM Test Facility will sign in on the Radiation Work Permit sheet at the beginning of each test day and sign out before they depart from the facility.

b. Due to ionizing and non-ionizing radiation produced by the sources at the facility, all personnel present during testing must comply with the instructions given to them by the facility operators. All visitors will be informed of approved areas when they first arrive to the facility.

c. If pictures and/or video have been requested, the TO must communicate to the media personnel what should be photographed and/or recorded. Any special requests, instructions, or test plan changes must be communicated to the facility operators immediately.

d. Engineering judgment becomes critical when schedule impacts occur such as facility downtime, inclement weather, failures, and/or re-prioritization. Under such conditions, the TO must determine the problem and contact the Army evaluator to seek guidance and approval to deviate from the original test plan, and devise an alternate plan or set of procedures.

4. TEST PROCEDURES.

4.1 Test Setup.

The facility operators will use the information obtained from the test plan and field characterization to place the test article in the field. The facility operators will have a measured map of the field intensity to insure that desired output characteristics can be reproduced prior to the test. The output characteristics of the facility should not vary more than 10% from what is requested. The test setup for each mission may vary depending on the test article and the requirements. Figures 3 and 4 each illustrate a test setup.



Figure 3. Narrowband test setup.

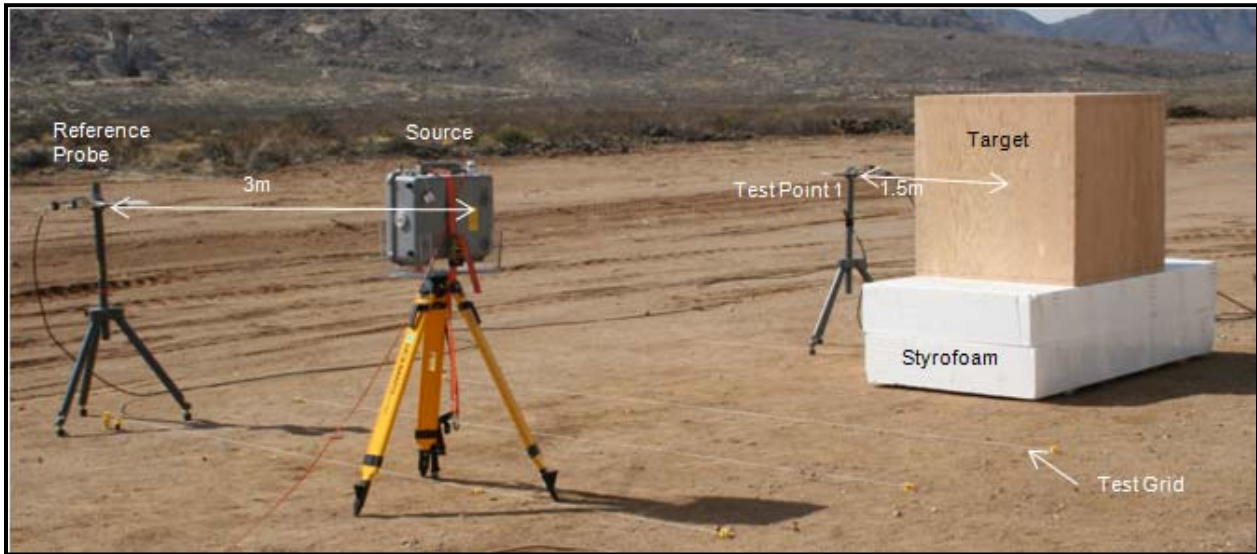

Figure 4. Wideband test setup.

4.2 Test Requirements.

- a. To assess the operational survivability and identify susceptibilities to the system when exposed to a HPM environment, as specified in MIL-STD 464C and current requirement documents as developed.
- b. The test article must meet its operational performance requirements after being exposed to the HPM environment.
- c. The test article shall remain operational without component replacement.

4.3 Test Procedure.

An overview of test procedures is given below. Take note that each test is unique and may require specific procedures unique to the mission.

- a. The procedures in this TOP will be conducted in compliance with all relevant site Standing Operation Procedures for the specific simulator used during testing. In addition, any special safety procedures to be followed for the duration of the mission should be established before any testing takes place.
- b. Facility operators will inspect, analyze, and ready the simulator(s) and related equipment before the first scheduled mission. Tasks also include:
 - (1) Verify the communication network is operational and working properly.

- (2) Check all subsystems for any indications of damage and/or unsafe conditions.
 - (3) Verify test instrumentation is properly connected.
- c. Place field probe(s) in designated locations.
 - d. Properly block off access to restricted areas and close perimeter gates.
 - e. Perform head count to determine if all personnel are accounted for and verify area is clear, using safety cameras or by performing a walk through, before turning on the siren and flashing lights.
 - f. Source operator will receive a “go-ahead” from safety personnel and data acquisition operator before the simulator is armed and fired. After a series of pulses have occurred the operator will safe the system and record all required transmitter data in the source Operations Log Book.
 - g. Complete a field characterization for every simulator at every level using a test probe before placing the test article in the field. The test article will be placed in the field once the field map has been completed.
 - h. Expose test article to the characterized environment. The performance of the simulator will be monitored by internal source diagnostics, if applicable. Test setup will be photographed for each test orientation and configuration, if applicable.
 - i. The data acquisition personnel will review information obtained, save, process, and make any necessary configuration changes.
 - j. The TO will analyze the impact of the HPM environment on the test article.
 - k. Repeatedly expose and analyze the test article for each specified environment, orientation, and polarization. The environment will be adjusted to generate the intended field intensity and the test article will be positioned in the proper location for exposure. This procedure will be repeated until the amount of requested data is obtained for all functional modes and system configurations.
 - l. If an anomaly or effect is observed testing shall not continue until the problem is understood and its effects on the test article are analyzed. In the event of an upset, the effected system(s) or sub-system(s) will be identified and power cycled in an attempt to re-establish normal operation and record the recovery time. Testing must be repeated at the same level and orientation to determine whether the upset is attributable to the current HPM environment.

5. DATA REQUIRED.

The following data will be supplied to the TO:

- a. A document containing test article configuration, frequency level(s), simulator identification, source configuration, and data measurements acquired.
- b. Complete set of pretest field characterization data.
- c. Complete set of data obtained during testing.
- d. Calibration files for instrumentation used during testing, if requested.
- e. Instrumentation characterization chains, if requested.

6. PRESENTATION OF DATA.

6.1 Data Analysis.

Test data acquired will be compared and analyzed against the criteria set forth in MIL-STD-464C and the test plan to determine if the test article met the criteria. If the test article fails to meet standards, the TO will document the test configuration and the field intensity it failed at. The criteria will be met if the test article operates and survives the simulated HPM environment it was exposed to.

6.2 Data Presentation.

- a. The facility operators will provide the TO with the following:
 - (1) Data spreadsheet summaries, obtained during field characterization and testing.
 - (2) Processed (corrected) time and frequency data, for all field probes and simulator diagnostics.
 - (3) Simulator information (i.e., source frequency, polarization, and shot number).
 - (4) All jpeg files for data analyzed.
- b. Figures 5 and 6 illustrate data obtained from a narrowband and wideband reference signal, respectively.

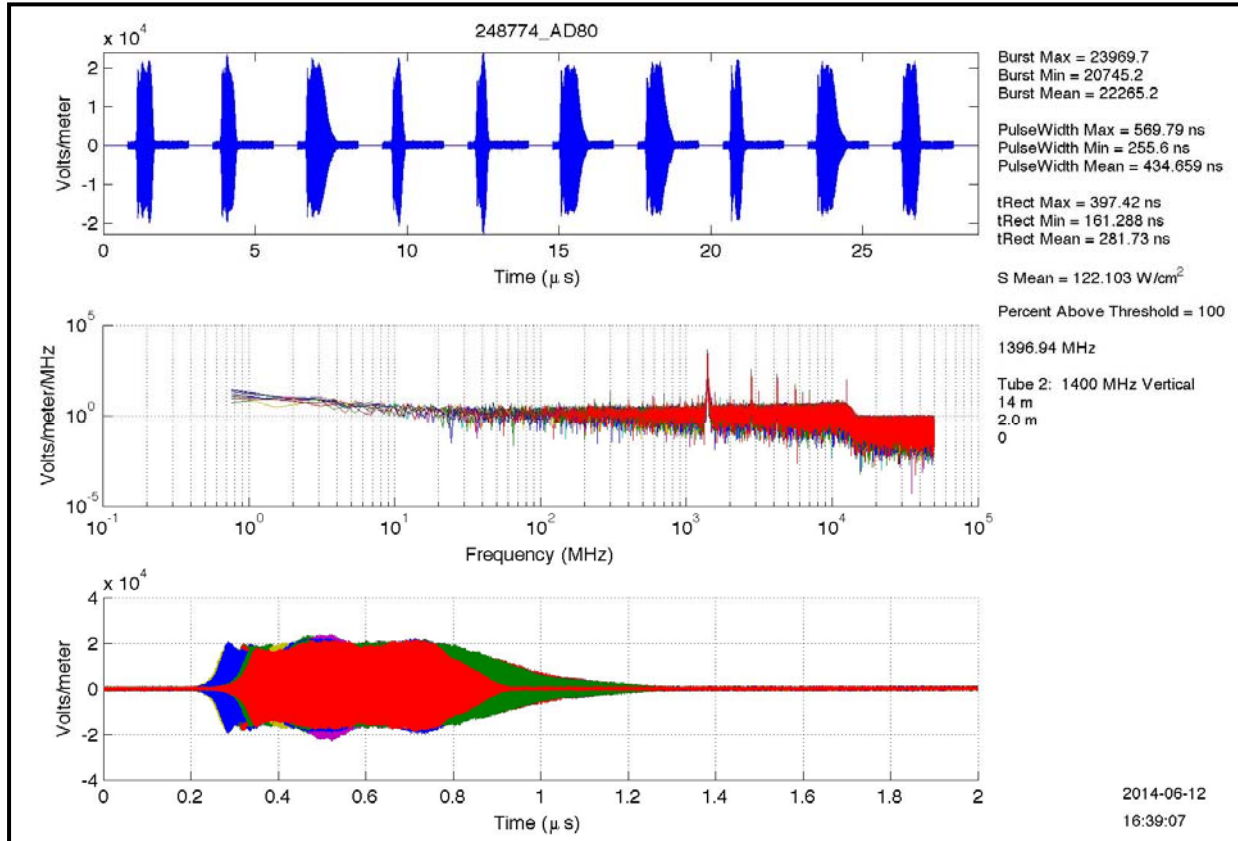

Figure 5. Narrowband signal reference probe data.

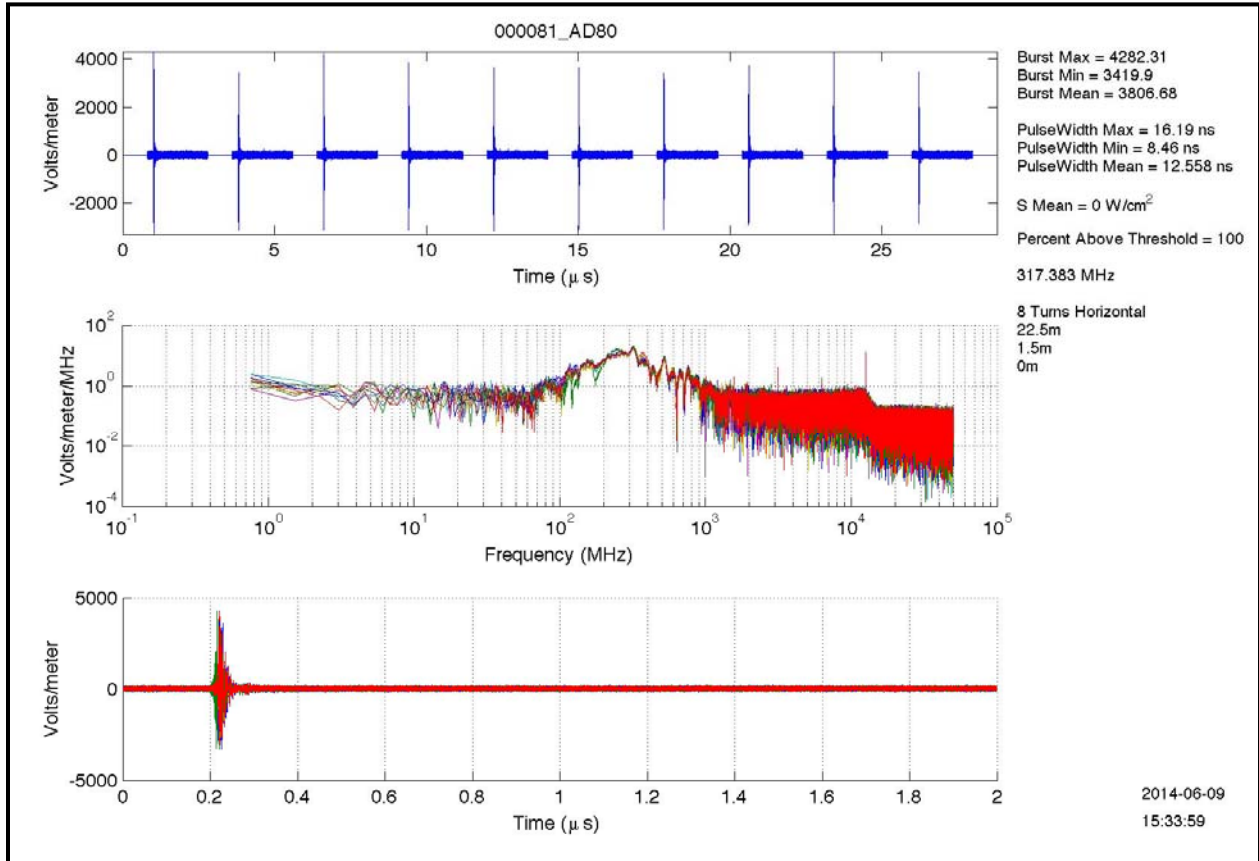

Figure 6. Wideband signal reference probe data.

APPENDIX A. DATA PROCESSING ALGORITHMS.

A.1 OVERVIEW OF DATA PROCESSING ALGORITHMS.

Figure A-1 illustrates a block diagram displaying the processes used to process HPM data. The sections below will provide a detailed description of each block.

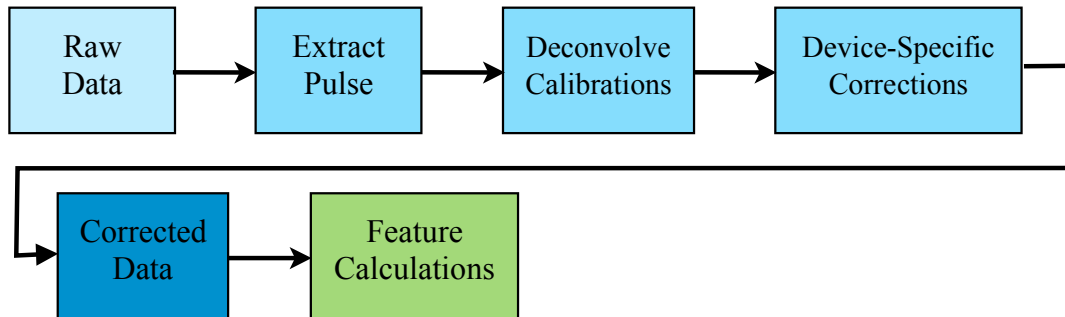

Figure A-1. Block diagram for data processing.

A.2 RAW DATA.

Figure A-2 illustrates the raw voltage trace from the digitizer used to capture the data. It is the voltage as seen by the digitizer without any correction or calibration factors applied.

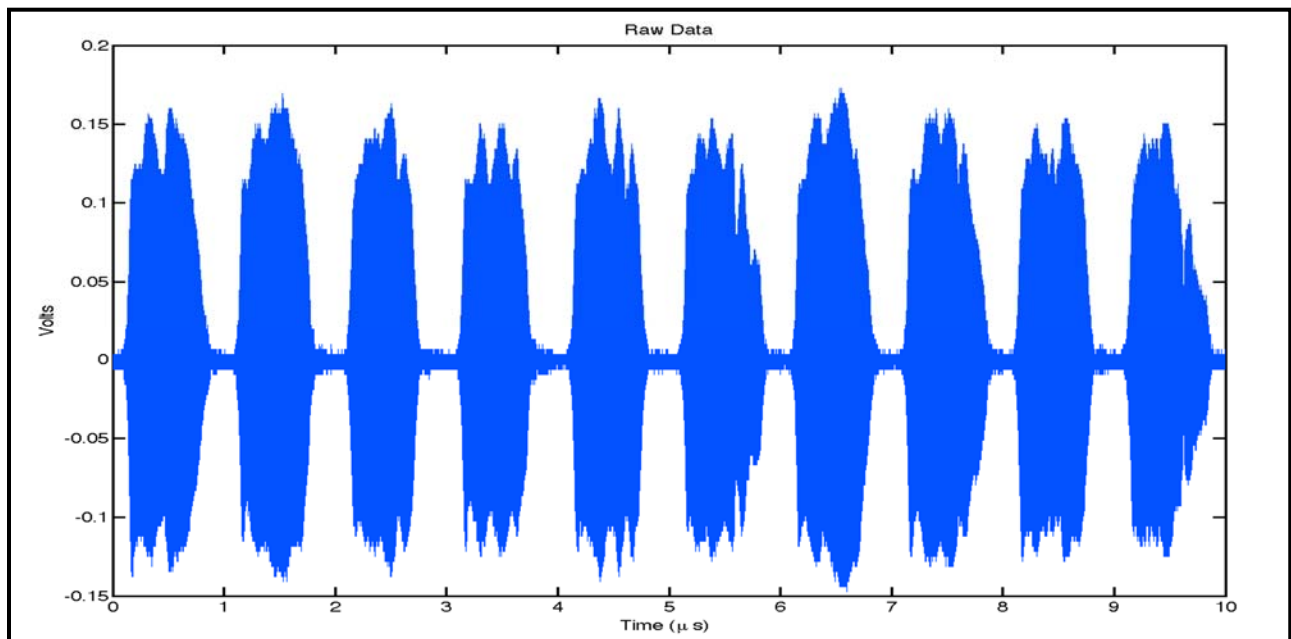

Figure A-2. Raw data.

APPENDIX A. DATA PROCESSING ALGORITHMS.

A.3 EXTRACT PULSE.

The raw data typically consists of a set of bursts which must be processed individually in order to calculate the corrected data for the measurement. This is done by separating the entire record displayed in Figure A-2 into individual pulses as shown in Figure A-3.

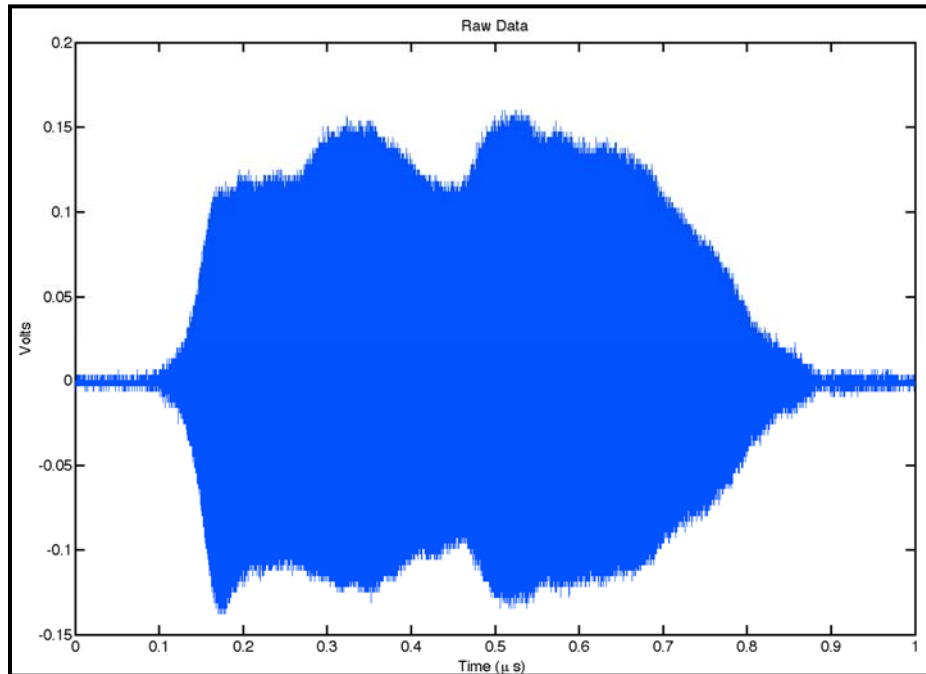

Figure A-3. Pulse extracted from raw data.

Additionally, the extracted pulse can be clipped to reduce the noise in the measurement or to remove any biasing from the signal. Figure A-4 illustrates a clipped pulse.

APPENDIX A. DATA PROCESSING ALGORITHMS.

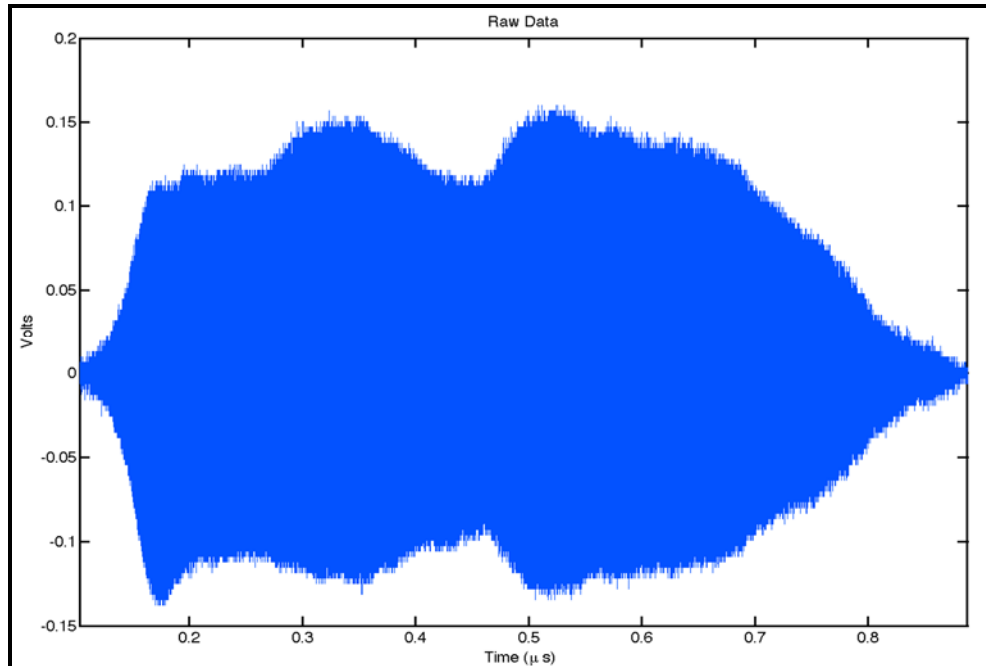

Figure A-4. Clipped pulse.

A.4 DECONVOLVE CALIBRATIONS.

In order to remove the effects of the instrumentation from a signal the calibration data for the instrumentation must be deconvolved from the signal. A signal represented as $x(t)$ is affected by a system $h(t)$ to produce an output $y(t)$ by the relationship:

$$y(t) = x(t) * h(t) = \int_{-\infty}^t x(\tau)h(t - \tau)d\tau \quad (\text{A.4.1})$$

which is the equation for convolution. Calculating the convolution integral in the time domain is a very inefficient process therefore the same result can be obtained using the Convolution/Multiplication property of the Fourier Transform:

$$y(t) = x(t) * h(t) \Rightarrow Y(f) = X(f)H(f) \quad (\text{A.4.2})$$

For a continuous time domain signal $x(t)$ the Continuous Fourier Transform (CFT) can be determined to be:

$$X(f) = \int_{-\infty}^{\infty} x(t)e^{-j2\pi ft} dt \quad (\text{A.4.3})$$

APPENDIX A. DATA PROCESSING ALGORITHMS.

A digitized signal $x[n]$ with a sampling period of Δt containing N samples can be approximated as:

$$X(f) = \sum_{n=0}^N x[n] e^{-j2\pi f n \Delta t} \quad (\text{A.4.4})$$

Using the Fast Fourier Transform (FFT) algorithm $X(f)$ can be found to be:

$$X(f) = FFT\{x[n]\} \cdot \Delta t \quad (\text{A.4.5})$$

Using an extracted pulse as shown in Figure A-3 $p[n]$ the deconvolution process can be described by the diagram in Figure A-5.

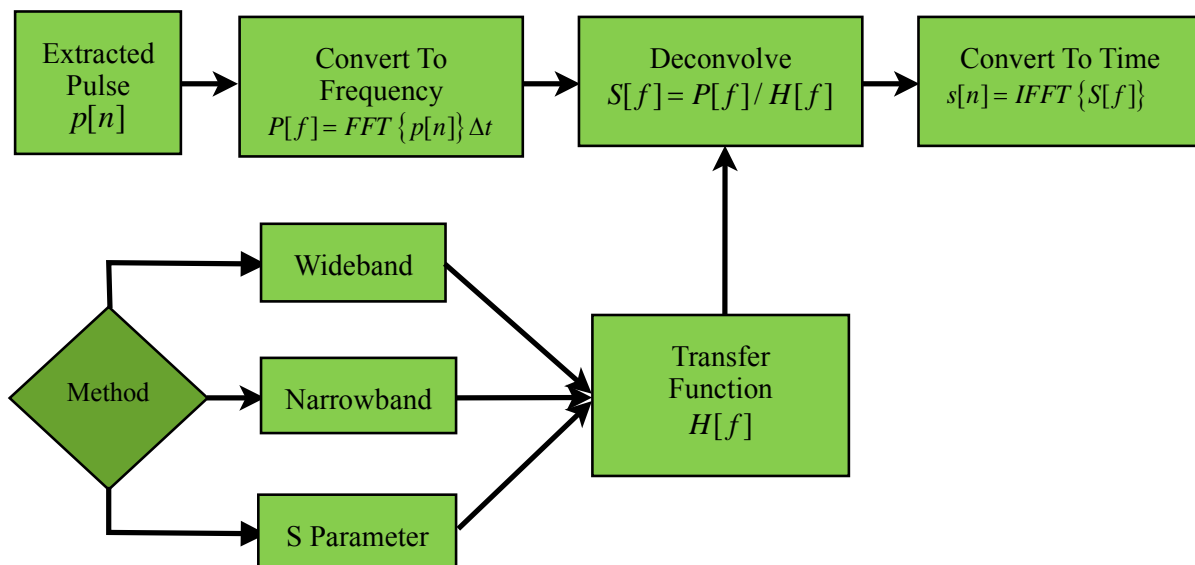

Figure A-5. Block diagram for deconvolution.

The extracted pulse $p[n]$ can be processed by one of three methods (Wideband, Narrowband, or S Parameter).

A.4.1 Narrowband Method.

The Narrowband method is used if the instrumentation has a calibration file which is piecewise. In other words, if the file is separated into discrete frequency bands with abrupt changes from one band to another such as for devices which can be switched to separate inputs. The algorithm used is shown below.

APPENDIX A. DATA PROCESSING ALGORITHMS.

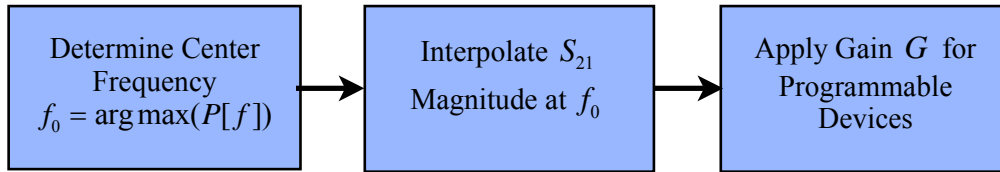

Figure A-6. Block diagram for narrowband method.

The center frequency is found from the spectrum $P[f]$ by determining the frequency at which $P[f]$ is maximized. For each calibration file within the instrument chain the magnitude of the S_{21} parameter is interpolated to the frequency f_0 using the following equation:

$$|S_{21}(f_0)| = |S_{21}(f_1)| + (|S_{21}(f_2)| - |S_{21}(f_1)|) \frac{f_0 - f_1}{f_2 - f_1} \quad (\text{A.4.1.1})$$

where f_2 is the nearest frequency greater than f_0 in the calibration file and f_1 is the nearest frequency less than f_0 in the calibration file.

Next, the gain for devices which have programmable gain is applied to the signal by the equation:

$$P(f) = P(f) \cdot 10^{\frac{G_{dB}}{20}} \quad (\text{A.4.1.2})$$

for a gain G in dB.

Finally, the $S_{21}(f_0)$ parameter is used as a transfer function $H[f]$ in order to obtain the corrected signal $S[f]$ from $P[f]$.

A.4.2 Wideband Method.

The Wideband method is used if the calibration files in the data contain only magnitude and phase data for the transmission parameter S_{21} of the instrumentation. This method is shown below:

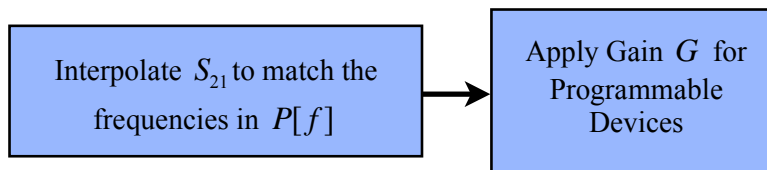

Figure A-7. Block diagram for wideband method.

APPENDIX A. DATA PROCESSING ALGORITHMS.

For all of the instrumentation in the instrument chain of a measurement the S_{21} parameter is interpolated to match the frequency spacing of the pulse spectrum $P[f]$ which is $\Delta f = (F_s/2)/N$, where $F_s = 1/\Delta t$ is the sampling rate of the digitized signal and N is the number of points in $P[f]$.

The magnitude of the calibration data can be interpolated by:

$$|S_{21}(f)| = |S_{21}(f_1)| + (|S_{21}(f_2)| - |S_{21}(f_1)|) \frac{f - f_1}{f_2 - f_1} \quad (\text{A.4.2.1})$$

The phase of the calibration data can be interpolated by:

$$\angle S_{21}(f) = \angle S_{21}(f_1) + (\angle S_{21}(f_2) - \angle S_{21}(f_1)) \frac{f - f_1}{f_2 - f_1} \quad (\text{A.4.2.2})$$

Additionally, the gain for any devices which have programmable gain is applied to the signal by using the equation (A.4.1.2).

Finally, the interpolated $S_{21}(f)$ parameter is used as the transfer function $H[f]$ for obtaining the corrected signal $S[f]$ from $P[f]$.

A.4.3 S Parameter Method.

The S Parameter method is used to correct for instrumentation which has a full S Parameter calibration file. The method is shown below.

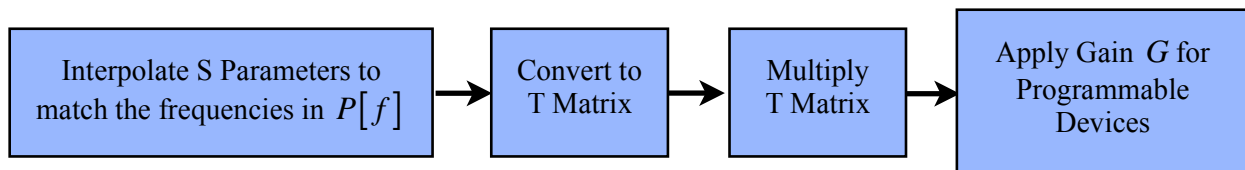

Figure A-8. Block diagram for S Parameter method.

For all instruments in the instrumentation chain of a measurement the full S matrix is interpolated to match the frequency spacing as was the case for the Wideband method. The interpolation algorithm is identical for both magnitude and phase as in the Wideband case except it will be for the entire S matrix. Again, the gain for programmable devices is taken into account using the relation (A.4.1.2).

For an interpolated S Parameter matrix shown below,

APPENDIX A. DATA PROCESSING ALGORITHMS.

$$[S] = \begin{bmatrix} S_{11} & S_{12} \\ S_{21} & S_{22} \end{bmatrix} \quad (\text{A.4.3.1})$$

a T matrix can be determined by:

$$[T] = \begin{bmatrix} \frac{S_{21}S_{12} - S_{11}S_{22}}{S_{21}} & \frac{S_{11}}{S_{21}} \\ -S_{22} & 1 \end{bmatrix} \quad (\text{A.4.3.2})$$

The T matrix has the property that it can be cascaded by multiplying the T matrix for each calibration file that is in the instrumentation chain. The final T matrix can be described by:

$$\mathbf{T} = T_1 T_2 \dots T_N \quad (\text{A.4.3.3})$$

The transfer function $H[f]$ can be obtained from (A.4.3.3) by taking the term $1/T_{22}$ from \mathbf{T} to determine the corrected signal $S[f]$ from $P[f]$.

Regardless of which method is chosen the corrected signal $S[f]$ can be calculated from the transfer function by dividing the transfer function from the uncorrected pulse:

$$S[f] = \frac{P[f]}{H[f]} \quad (\text{A.4.3.4})$$

From the frequency domain representation of the corrected signal $S[f]$ the time domain signal can be found by taking the inverse Fourier transform which in the continuous domain is:

$$s(t) = \int_{-\infty}^{\infty} S(f) e^{j2\pi ft} df \quad (\text{A.4.3.5})$$

The discrete time signal can be approximated as:

$$s[n] = \sum_{n=0}^N S[f] e^{j2\pi f \Delta t} \Delta f \quad (\text{A.4.3.6})$$

APPENDIX A. DATA PROCESSING ALGORITHMS.

Using the Inverse Fast Fourier Transform (IFFT) algorithm $s[n]$ can be found to be:

$$s[n] = IFFT \left\{ \left[S[f]_{n=1 \dots \frac{N}{2}+1} \quad S^*[f]_{n=N/2 \dots N} \right] \right\} \quad (\text{A.4.3.7})$$

where $S^*[f]$ represents the complex conjugate of $S[f]$.

A.5 DEVICE-SPECIFIC CORRECTIONS.

This block from Figure A-1 is used to correct for various types of devices which differ from the deconvolve procedure described in Section A.4. These devices are RF diodes and power measuring devices such as directional couplers.

A.5.1 RF Diodes.

An RF diode, or PIN diode, is a device which converts a pulse into the envelope of the pulse. The calibration data for the diode can be represented by a quadratic curve which is a function of output voltage to input voltage for each frequency that it is calibrated for. A set of three coefficients is used to represent these data. The voltage is corrected for all instrumentation from the digitizer to the diode as described in Section A.4. The output signal from the deconvolution procedure $s[n]$ is used as the input to the curve fit expression:

$$\begin{aligned} s_i[n] &= s[n] \\ A s_i^2[n] + B s_i[n] + C &= s_o[n] \\ s[n] &= s_0[n] \end{aligned} \quad (\text{A.5.1.1})$$

where the parameters A, B, and C are the coefficients of the diode for the frequency f_0 . The frequency f_0 must be known by other means since the frequency content of the signal is lost due to the envelope detection of the diode.

For the instrumentation from the diode to the sensing device the Narrowband algorithm described in paragraph A.4.1 is used to deconvolve the instrumentation at the frequency, f_0 .

A.5.2 Directional Couplers.

A directional coupler is used to measure power flow through a transmission line whether it's a waveguide or coaxial line. The directional coupler can be represented as a multi-port device which has separate calibration data for a pair of ports. A standard coupler is shown below.

APPENDIX A. DATA PROCESSING ALGORITHMS.

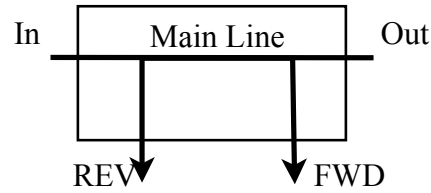

Figure A-9. Schematic of a directional coupler.

In order to calculate the power through a directional coupler, the signal must be deconvolved as described in Section A.4. The output voltage is then converted to power by the equation:

$$\begin{aligned}
 s_i[n] &= s[n] \\
 s_o[n] &= \frac{s^2[n]}{50} \\
 s[n] &= s_o[n]
 \end{aligned}
 \tag{A.5.2.1}$$

A.6 CORRECTED DATA.

The block labeled Corrected Data in Figure A-1 takes the signals from the previous block $s[n]$ and, if the signals are part of a burst, reconstructs the original pulse train with corrected pulses as shown below.

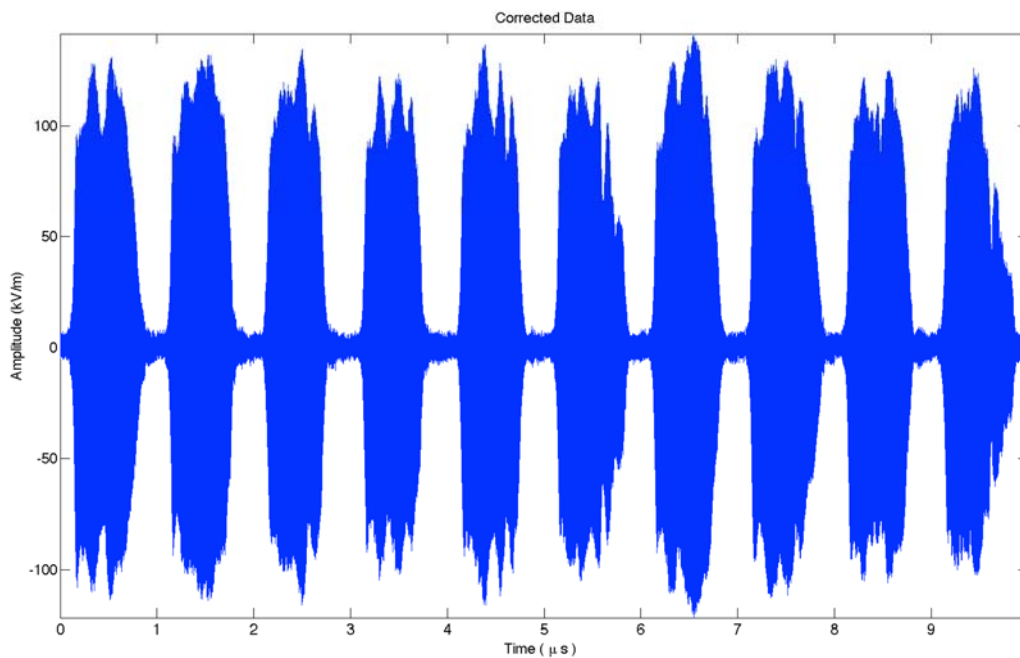

Figure A-10. Corrected pulse train.

APPENDIX A. DATA PROCESSING ALGORITHMS.

A.7 FEATURE CALCULATION.

In this section the metrics calculated for each pulse are summarized.

A.7.1 Power Density.

For an electromagnetic wave the power density of the wave can be expressed by the Poynting vector:

$$S = E \times H^* \quad (\text{A.7.1.1})$$

where S is the power density in W/m^2 , E is the electric field intensity in V/m , and H is the magnetic field intensity in A/m . For a plane wave in the far field in free space, the power density can be calculated from either the magnetic field intensity or the electric field intensity due to their relation:

$$E = \eta H \quad (\text{A.7.1.2})$$

where η is the impedance of free space which is equal to $120\pi \Omega = 377 \Omega$.

For a measured electric field intensity:

$$S = \frac{|E|^2}{\eta} \quad (\text{A.7.1.3})$$

For a measured magnetic field intensity:

$$S = \eta |H|^2 \quad (\text{A.7.1.4})$$

The normalized maximum power density is recorded for each pulse in the burst by taking the average of all points greater than 90% of the maximum power density thereby reducing the effect of a small set of samples skewing the power density calculation. The maximum normalized power density, then minimum normalized power density, and the mean normalized power density over a specified threshold (typically -3 dB of the maximum) is calculated for the entire set of pulses in the burst and is recorded in a spreadsheet and a database.

A.7.2 Risetime (10-90%).

The rise time of a signal is the time it takes for a signal to increase from 10% of the maximum value to 90% of the maximum value. For a narrowband signal this is performed on either the power or power density of the signal, and in the wideband case this is performed on voltage, current, or field intensity signal. In some cases, an average of the magnitude of all points greater than 90% of the absolute maximum is used in place of the maximum for determination of the 10% and 90% threshold in accordance with a Military Handbook (MIL-HDBK) for Electronic Warfare according to the requirements of the test plan.

APPENDIX A. DATA PROCESSING ALGORITHMS.

A.7.3 Pulse Width (Full Width Half Max).

The pulse width of a signal is the time that the magnitude of the signal is of the maximum value. For a narrowband signal this is performed on either the power or power density of the signal, and in the wideband case this is performed on voltage, current, or field intensity signal. In some cases, an average of the magnitude of all points greater than 90% of the absolute maximum is used in place of the maximum for determination of the 10% and 90% threshold in accordance with a MIL-HDBK for Electronic Warfare according to the requirements of the test plan.

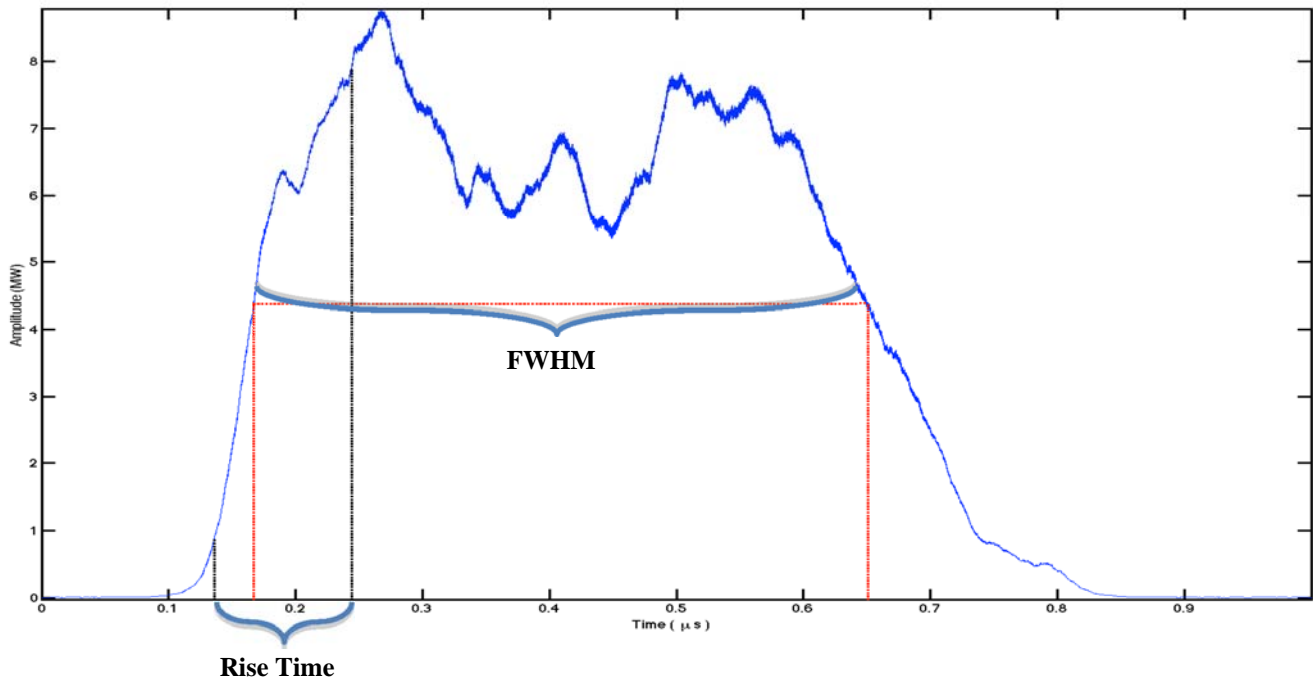

Figure A-11. Graphical representation of pulse width and rise time calculations.

A.7.4 Pulse Length (Rectangular).

A measure of pulse length which is often used in regards to radar transmitters and receivers is the length of a pulse with a rectangular wave shape. This calculation is performed by calculating the energy in a pulse over the interval in which the pulse initially rises above 10% to the time in which the pulse falls below 10% as shown below.

The pulse length shown in Figure A-12 the dashed red line is calculated using the formula:

$$\tau_{rect} = \frac{\sum_{i=t_{10r}}^{t_{10f}} P_i[n] \Delta t}{P_{max} / 2} \quad (A.7.4.1)$$

APPENDIX A. DATA PROCESSING ALGORITHMS.

where τ_{rect} is the length of the a rectangular pulse with an amplitude P_{max} where P_{max} is calculated by averaging the samples in the pulse whose magnitude is greater than 90% of the absolute peak of the signal. The term $P_i[n]$ is the i^{th} sample of the pulse $P[n]$ which is either the power or power density of the signal $s[n]$ from Section A.6.

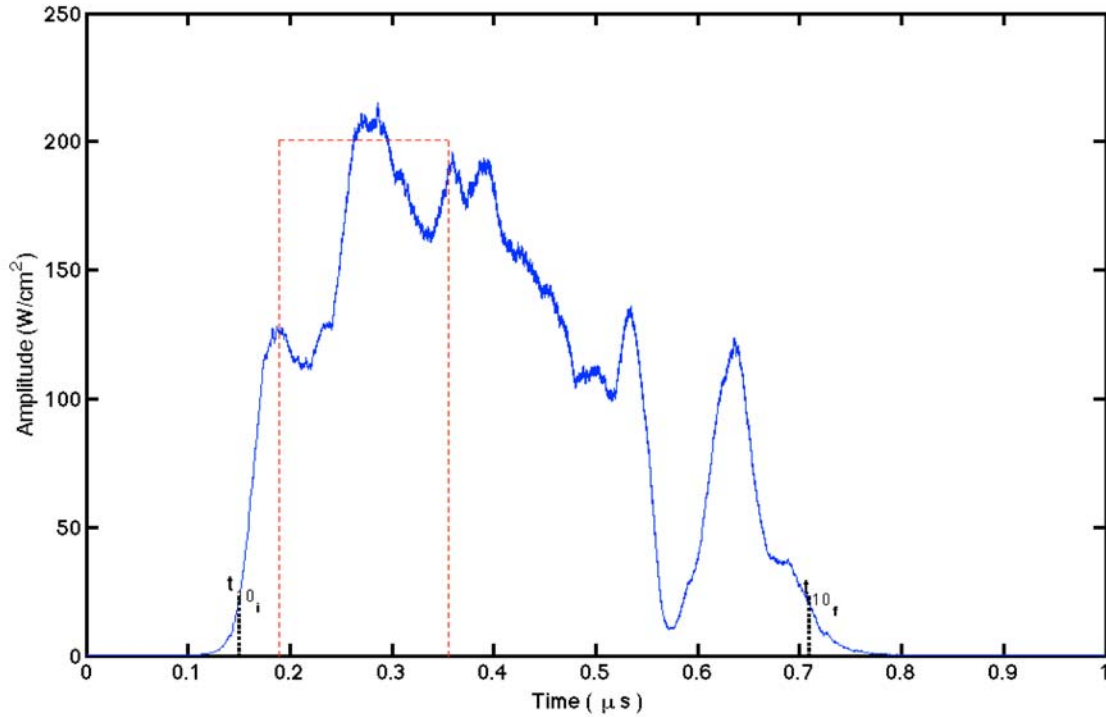

Figure A-12. Pulse length calculation.

APPENDIX B. HPM TEST PLAN.

The WSMR HPM test plan that must be filled out and submitted for approval two weeks prior to testing may be found below. Please contact the facility specialist if any questions arise while filling out this form.

Project Information

Project Name _____	ADSS Number _____	WBS _____	Classification <u>Please select one</u>
Start Date _____	End Date _____	Phone Number _____	Test Officer _____
Estimated Overtime Hours _____			
Test Platform <input type="checkbox"/> ARMY <input type="checkbox"/> NAVY <input type="checkbox"/> AIR FORCE <input type="checkbox"/> COMMERCIAL			

Visitor Information

Name	Area Briefing	Phone
_____	<input type="checkbox"/>	_____
_____	<input type="checkbox"/>	_____
_____	<input type="checkbox"/>	_____
_____	<input type="checkbox"/>	_____

Test Article Information

Dimensions, L*W*H (m) _____	Weight _____	Power Requirements _____
Additional _____		

Media Requirements

<input type="checkbox"/> Photos	<input type="checkbox"/> Video
---------------------------------	--------------------------------

Test Equipment Setup

Number of Field Probes _____	Number of Current Probes (if applicable) _____
Other Specifications: _____	

APPENDIX B. HPM TEST PLAN.

Test Specifications

	<u>Frequencies Available (MHz)</u>	<u>E-Field Level(s) Required</u>	<u>Polarization(V/H)</u>	<u>Pulse Width</u>	<u>Rep. Rate</u>
<input type="checkbox"/> Narrowband	<input type="checkbox"/> C: 387-485 <input type="checkbox"/> <input type="checkbox"/> A: 1000-1660 <input type="checkbox"/> <input type="checkbox"/> A Prime: 1700-2680 <input type="checkbox"/> <input type="checkbox"/> Reltron: 500-960 <input type="checkbox"/> 1140-1450 <input type="checkbox"/> 1800-3000 <input type="checkbox"/> <input type="checkbox"/> B: 8300, 8700, 9300, 9500, 10700, 11300, 11700 <input type="checkbox"/>	<input type="checkbox"/> <input type="checkbox"/> <input type="checkbox"/> <input type="checkbox"/> <input type="checkbox"/> <input type="checkbox"/> <input type="checkbox"/> <input type="checkbox"/> <input type="checkbox"/>	Please select one Please select one Please select one Please select one Please select one Please select one Please select one	<input type="checkbox"/> <input type="checkbox"/> <input type="checkbox"/> <input type="checkbox"/> <input type="checkbox"/> <input type="checkbox"/> <input type="checkbox"/> <input type="checkbox"/> <input type="checkbox"/>	<input type="checkbox"/> <input type="checkbox"/> <input type="checkbox"/> <input type="checkbox"/> <input type="checkbox"/> <input type="checkbox"/> <input type="checkbox"/> <input type="checkbox"/> <input type="checkbox"/>
<input type="checkbox"/> Wideband	<input type="checkbox"/> DIEHL: 125-311 <input type="checkbox"/> RS105: <input type="checkbox"/> UW BTS: 600-4200 <input type="checkbox"/> WBTS: 220-6000	<input type="checkbox"/> <input type="checkbox"/> <input type="checkbox"/> <input type="checkbox"/>	Please select one	<input type="checkbox"/> <input type="checkbox"/> <input type="checkbox"/> <input type="checkbox"/>	<input type="checkbox"/> <input type="checkbox"/> <input type="checkbox"/> <input type="checkbox"/>

Additional Requests

The proposed frequency list for the HPM facility is listed below.

Source	Primary Frequencies (MHz)	Alternate Frequencies (MHz)
NBTS C	387, 435, 480	390, 430, 485
NBTS A	1030, 1080, 1150, 1200, 1330, 1400, 1500, 1600, 1660	1000, 1090, 1170, 1180, 1310, 1440, 1450, 1570, 1650
NBTS A Prime	1760, 1830, 1900, 1960, 2150, 2200, 2240, 2450, 2620	1700, 1815, 1930, 1940, 2080, 2220, 2230, 2420, 2600
NBTS B	8300, 9300, 10700, 11700	8700, 9500, 11300
Reltron	500, 540, 600, 720, 755, 775, 850, 912, 950, 1178, 1341, 1395, 1890, 2000, 2140, 2250, 2375, 2650, 2700, 2750, 2800	520, 560, 580, 660, 730, 800, 880, 960, 1140, 1295, 1400, 1800, 1980, 2150, 2200, 2400, 2550, 2720, 2755, 2780

APPENDIX B. HPM TEST PLAN.

A generic example of an HPM test plan follows.

Project Information

Project Name <u>Example</u>	ADSS Number <u>D1234</u>	WBS <u>A.0003581.02</u>	Classification <u>Confidential</u>
Start Date <u>11/07/2011</u>	End Date <u>11/18/2011</u>	Phone Number <u>555-555-5557</u>	Test Officer <u>John Doe</u>
Estimated Overtime Hours <u>10</u>			
Test Platform <input type="checkbox"/> ARMY <input type="checkbox"/> NAVY <input type="checkbox"/> AIR FORCE <input checked="" type="checkbox"/> COMMERCIAL			

Visitor Information

Name	Area Briefing	Phone
<u>Brian McIntyre</u>	<input checked="" type="checkbox"/>	<u>555-555-5556</u>
<u> </u>	<input type="checkbox"/>	<u> </u>
<u> </u>	<input type="checkbox"/>	<u> </u>
<u> </u>	<input type="checkbox"/>	<u> </u>

Test Article Information

Dimensions, LxWxH (m) <u>1x1x2</u>	Weight <u>10 lbs</u>	Power Requirements <u>N/A</u>
Additional <u> </u>		

Media Requirements

<input checked="" type="checkbox"/> Photos	<input type="checkbox"/> Video
--	--------------------------------

Test Equipment Setup

Number of Field Probes <u>2</u>	Number of Current Probes (if applicable) <u>N/A</u>
Other Specifications: <u> </u>	

APPENDIX B. HPM TEST PLAN.

Test Specifications

	<u>Frequencies Available (MHz)</u>	<u>E-Field Level(s) Required</u>	<u>Polarization(V/H)</u>	<u>Pulse Width</u>	<u>Rep. Rate</u>
<input checked="" type="checkbox"/> Narrowband	<input type="checkbox"/> C: 387-485 _____ <input type="checkbox"/> A: 1000-1660 _____ <input checked="" type="checkbox"/> A Prime: 1700-2680 1830,1960 <input type="checkbox"/> Reltron: 500-960 _____ 1140-1450 _____ 1800-3000 _____ <input type="checkbox"/> B: 8300, 8700, 9300, 9500, 10700, 11300, 11700 _____	_____ _____ 15 kV/m _____ _____ _____ _____	Please select one Please select one Both Please select one Please select one Please select one Please select one	_____ _____ _____ _____ _____ _____ _____	_____ _____ _____ _____ _____ _____ _____
<input type="checkbox"/> Wideband	<input type="checkbox"/> DIEHL: 125-311 <input type="checkbox"/> RS105: <input type="checkbox"/> UWBTS: 600-4200 <input type="checkbox"/> WBTS: 220-6000	_____ _____ _____ _____	Please select one	_____ _____ _____ _____	_____ _____ _____ _____

Additional Requests

<u>Stand to support device under test during testing.</u>

The proposed frequency list for the HPM facility is listed below.

Source	Primary Frequencies (MHz)	Alternate Frequencies (MHz)
NBTS C	387, 435, 480	390, 430, 485
NBTS A	1030, 1080, 1150, 1200, 1330, 1400, 1500, 1600, 1660	1000, 1090, 1170, 1180, 1310, 1440, 1450, 1570, 1650
NBTS A Prime	1760, 1830, 1900, 1960, 2150, 2200, 2240, 2450, 2620	1700, 1815, 1930, 1940, 2080, 2220, 2230, 2420, 2600
NBTS B	8300, 9300, 10700, 11700	8700, 9500, 11300
Reltron	500, 540, 600, 720, 755, 775, 850, 912, 950, 1178, 1341, 1395, 1890, 2000, 2140, 2250, 2375, 2650, 2700, 2750, 2800	520, 560, 580, 660, 730, 800, 880, 960, 1140, 1295, 1400, 1800, 1980, 2150, 2200, 2400, 2550, 2720, 2755, 2780

APPENDIX C. CALIBRATION PROCEDURES.

C.1 All test and measurement instrumentation are characterized and calibrated to ensure accurate data are recorded during testing. The following test equipment is calibrated annually by a calibration lab using NIST traceable procedures: Network Analyzer, Electronic Calibration (E-Cal) Module, Spectrum Analyzer, Oscilloscopes, and Pulse generator.

C.2 The rest of the test equipment is calibrated at the HPM Test Facility. The items calibrated at the Test Site are classified into different classes. Class types and items included in each class are as follows:

- a. Node: Cables, Baluns, Attenuators, Diodes, Digital Filters, and Feed-thru Filters
- b. Sensor: DDot, BDot, Standard Gain Horns, Open Ended Waveguides, Current Probes, Directional Couplers
- c. ODT: Fiber Optic transmitter to receiver pairs
- d. Digitizer: Oscilloscopes
- e. HPA: High Power Attenuator
- f. Video: Video files

C.3 The following calibration procedures are performed at the Test Site.

C.3.1 Fiber Optics Calibration Procedure.

Fiber optic cables are calibrated as pairs, transmitter to receiver. The procedure used to calibrate the ODS-1500 fiber optic links is as follows:

- a. Startup the server workstation.
- b. Power on the Network Analyzer and allow it to warm up for 30 minutes.
- c. Setup the Network Analyzer parameters as follows:

Number of points: 4096
Start Frequency: 300 kHz
Stop Frequency: 3.0 GHz
Power Level: 0 dBm
Resolution BW: 1000 Hz
- d. Perform an eCal calibration to calibrate the network analyzer and the cables used to connect the network analyzer to the item to be calibrated. Figure C-1 illustrates this configuration.

APPENDIX C. CALIBRATION PROCEDURES.

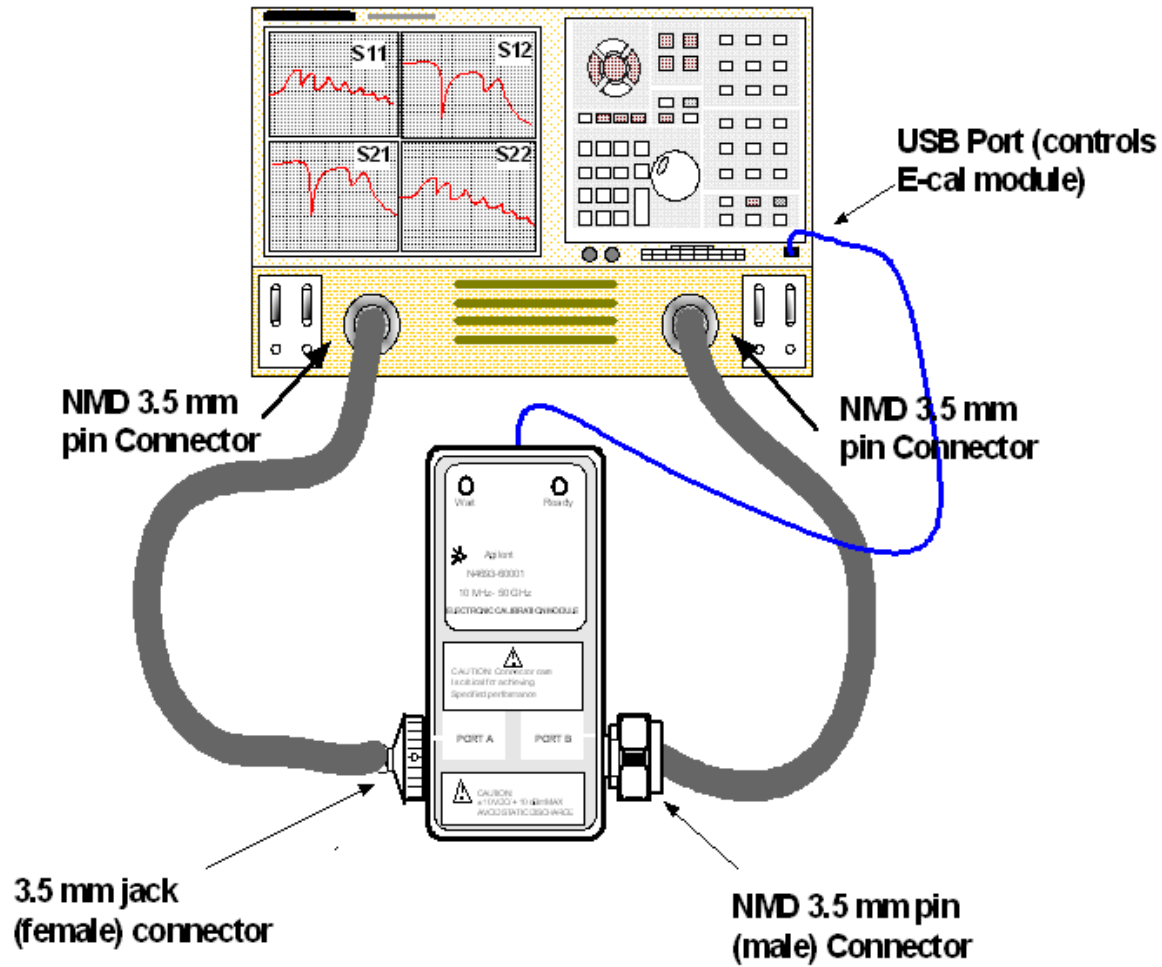

Figure C-1. Network analyzer calibration configuration.

- e. Remove the E-Cal module.
- f. Connect and configure the transmitters as follows:
 - (1) Verify the fiber ends are clean and then connect to the transmitter to be calibrated.
 - (2) Attach the other end of the fibers to the appropriate receiver input.
 - (3) Auto Detect the transmitters using the Optical Status interface.
- g. Connect the calibrated cables to the transmitter and receiver. The cable from Port 1 of the network analyzer should be connected to channel 1 of the transmitter. The cable from Port 2 of the network analyzer should be connected to the receiver. Refer to Figure C-2 for configuration setup.

APPENDIX C. CALIBRATION PROCEDURES.

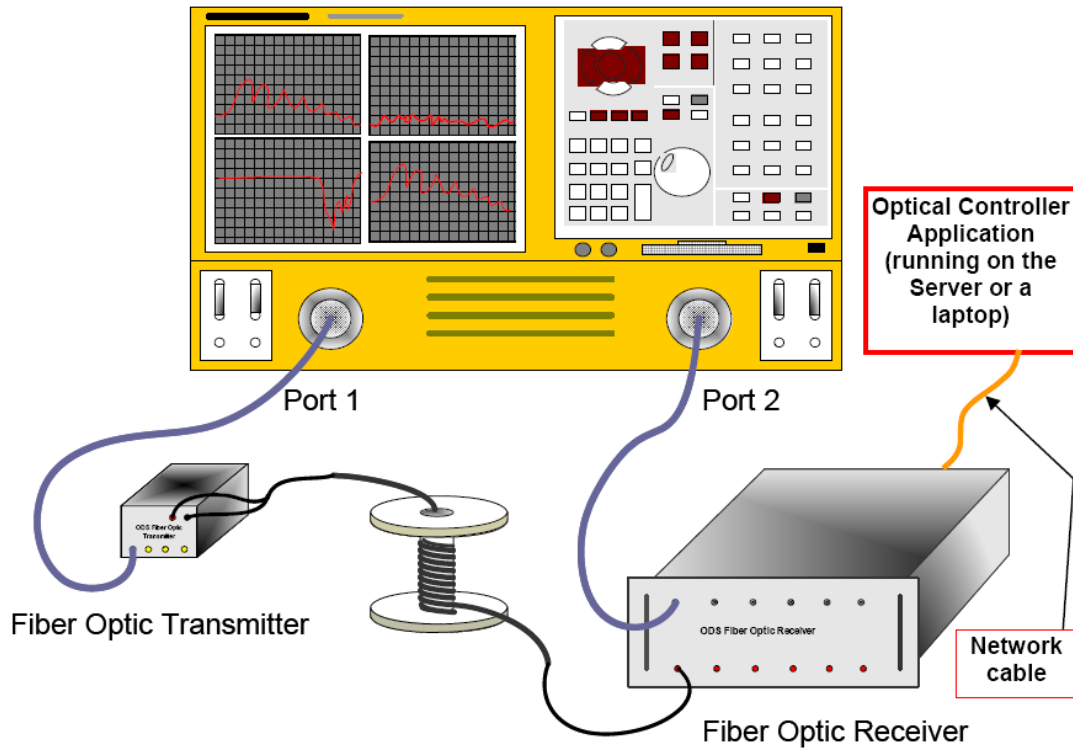

Figure C-2. Fiber optic calibration characterization.

h. Start the Calibration Application and select the New tab. Figure C-3 illustrates the New Cal File window that should open.

i. In the New Calibration File window enter the following information in each field and press Accept when finished:

Name: Receiver-Transmitter Serial Number
Class select ODT
Type: ODT-15

j. Select the Open Config tab.

k. Enter the IP address for the Network Analyzer to be used and Analyzer Model information and press Connect.

APPENDIX C. CALIBRATION PROCEDURES.

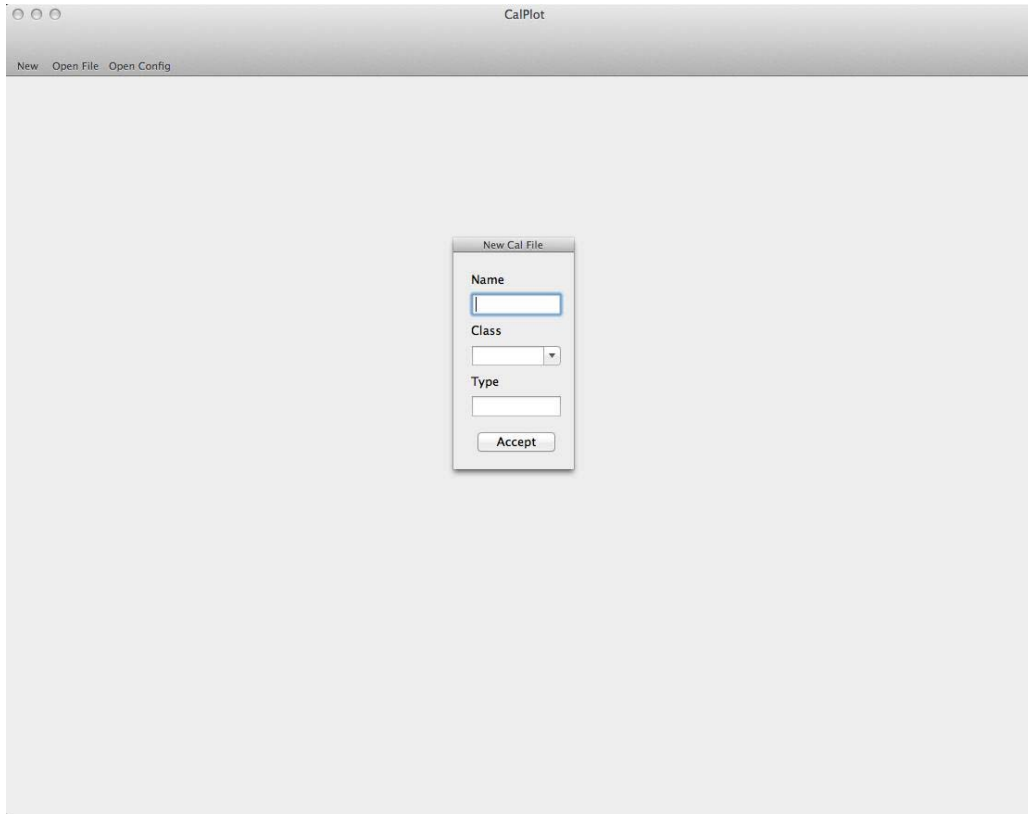

Figure C-3. New calibration file screen.

1. In the Configuration window enter the following sweep setup calibration parameters:

Start Frequency	3 e+5
End Frequency	3 e+9
Power	0
Number of Points	4096
URL	Receiver IP Address
- m. Press the “Run Cal Cycle” button. The analyzer will perform the calibration sweep.
- n. After the calibration sweep is complete close the Configuration window to view the calibration. Figure C-4 illustrates a fiber optic calibration curve.
- o. After the calibration sweep is complete disconnect the cable from the receiver to the network analyzer and connect to an oscilloscope.
- p. On the Configuration tab press the Manual Entry button.

APPENDIX C. CALIBRATION PROCEDURES.

- q. Enter the Scope IP address and Scope Channel number in the window that opens.
- r. Press the Cal Pulse button then the Close button.
- s. In the Configuration tab and press Save Calibration.

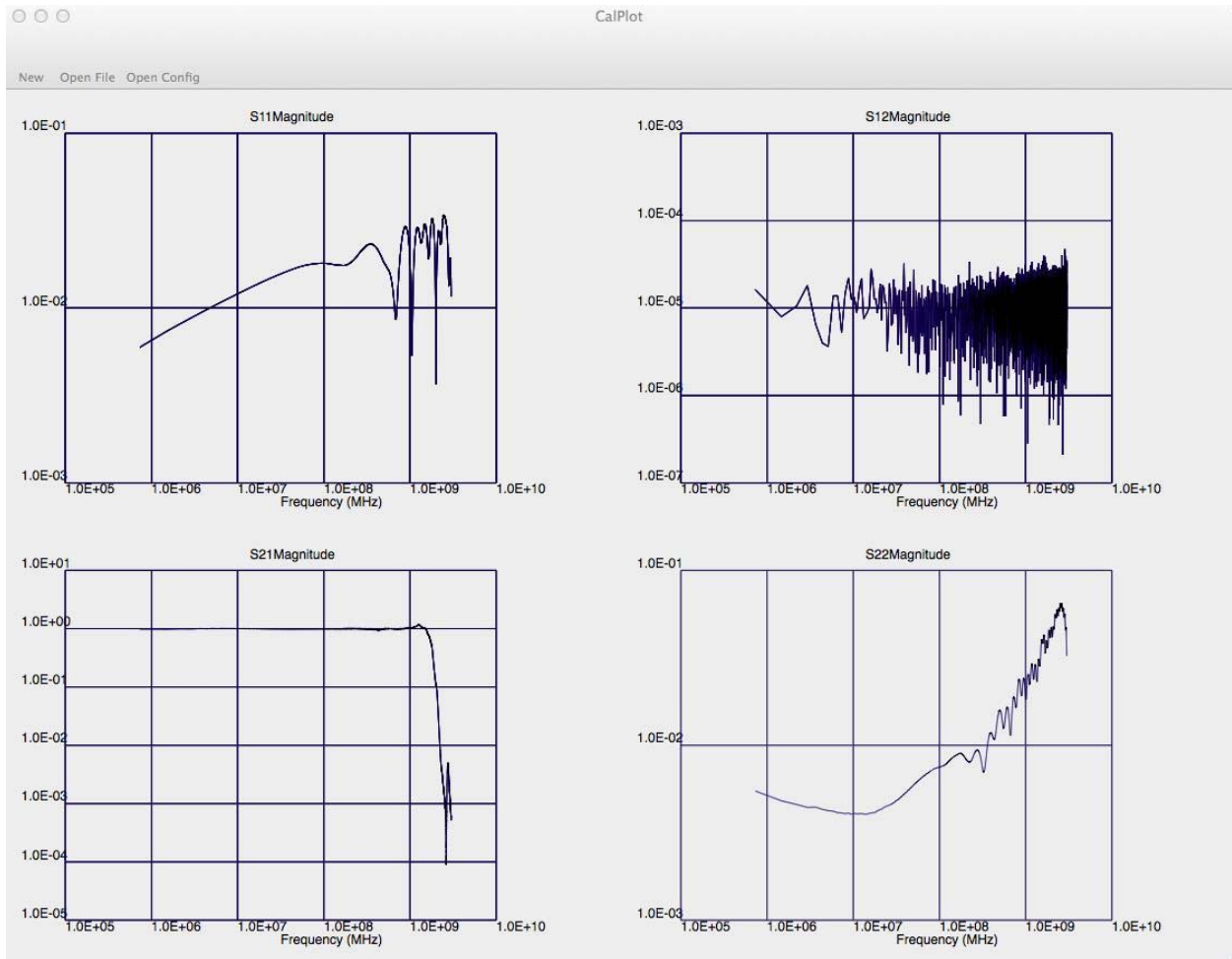

Figure C-4. Fiber optic calibration configuration.

C.3.2 Cable Calibration Procedure.

The following procedure is used to calibrate coaxial and sucoflex cables.

- a. Startup the server workstation.
- b. Power on the Network Analyzer and allow it to warm up for 30 minutes.

APPENDIX C. CALIBRATION PROCEDURES.

- c. Setup the Network Analyzer parameters as follows:

Number of points: 4096
Start Frequency: 300 kHz
Stop Frequency: 13.5 GHz
Power Level: 0 dBm
Resolution BW: 1000 Hz

d. Perform an eCal calibration to calibrate the network analyzer and the cables used to connect the network analyzer to the coaxial/sucoflex cable. Figure C-1 illustrates this configuration.

- e. Remove the E-Cal module and replace with the coaxial/sucoflex cable to be calibrated.

f. Start the Calibration Application and select the New tab. Figure C-3 illustrates the New Cal File window that should open.

g. In the New Calibration File window enter the following information in each field and press Accept when finished:

Name: Cable type and Serial Number
Class select Node
Type: Cables

- h. Select the Open Config tab.

i. Enter the IP address for the Network Analyzer to be used and Analyzer Model information and press Connect.

- j. In the Configuration window enter the following sweep setup calibration parameters:

Start Frequency 3e+5
End Frequency 1.35 e+10
Power 0
Number of Points 4096

- k. Press the “Run Cal Cycle” button. The analyzer will perform the calibration sweep.

l. After the calibration sweep is complete close the Configuration window to view the calibration. Figure C-5 illustrates a sucoflex calibration curve.

- m. Open the Configuration tab and press Save Calibration.

APPENDIX C. CALIBRATION PROCEDURES.

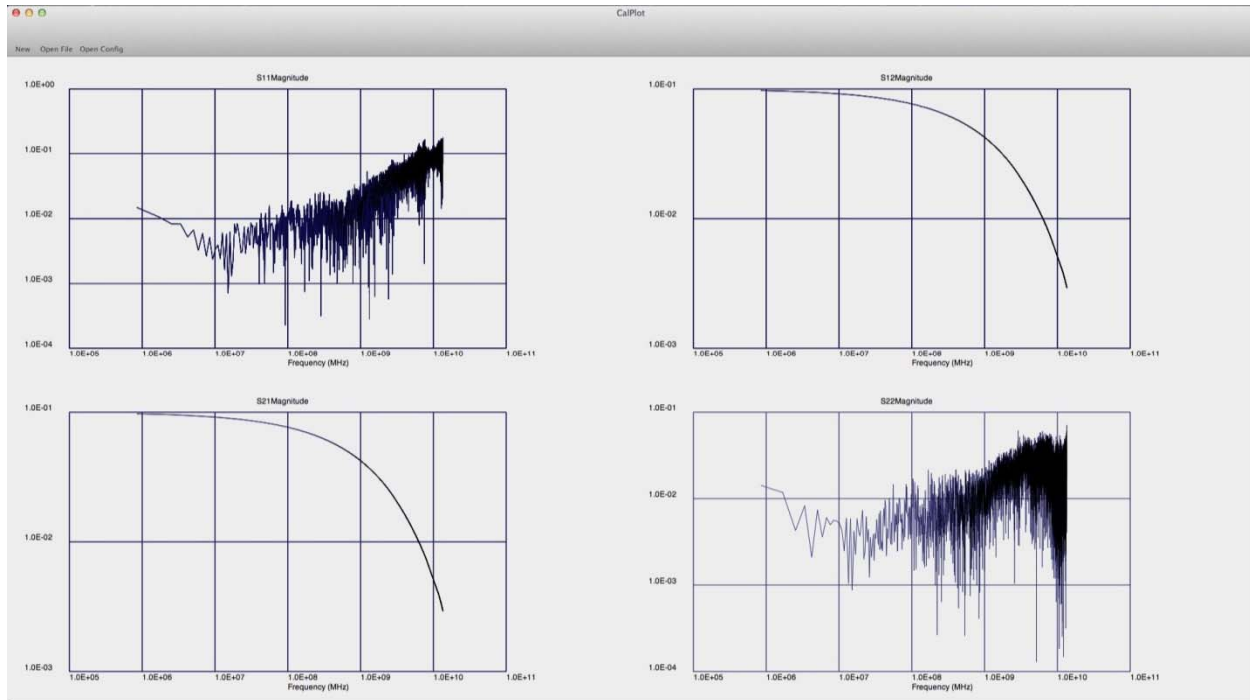

Figure C-5. Sucoflex cable calibration.

C.3.3 Balun Calibration Procedure.

Baluns are calibrated using an analytic approach. Since baluns have two inputs and one output, the calibration is performed on both sides independently.

- a. Startup the server workstation.
- b. Power on the Network Analyzer and allow it to warm up for 30 minutes.
- c. Setup the Network Analyzer parameters as follows:

Number of points: 4096
Start Frequency: 1 kHz
Stop Frequency: 13.5 GHz
Power Level: 0 dBm
Resolution BW: 1000 Hz

d. Perform an eCal calibration to calibrate the network analyzer and the cables used to connect the network analyzer to the balun. Figure C-1 illustrates this configuration.

- e. Remove the E-Cal module and replace with the balun to be calibrated.

APPENDIX C. CALIBRATION PROCEDURES.

f. Start the Calibration Application and select the New tab. Figure C-3 illustrates the New Cal File window that should open.

g. In the New Calibration File window enter the following information in each field and press Accept when finished:

Name: Balun Type and Serial Number
Class select Node
Type: Balun

h. Configure the balun and cabling as shown in Figure C-6.

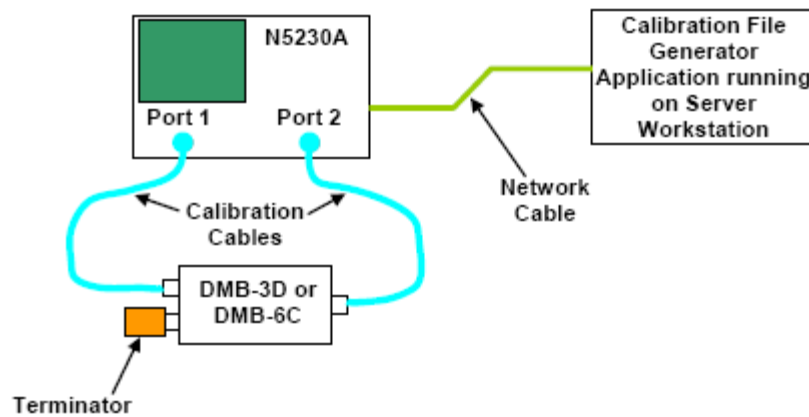

Figure C-6. Balun calibration configuration.

i. Select the Open Config tab.

j. Enter the IP address for the Network Analyzer to be used and Analyzer Model information and press Connect.

k. In the Calibration Application window enter the following Sweep Setup calibration parameters:

Start Frequency	1e+3
End Frequency	13.5e+9
Power	0
Number of Points	4096

l. Press the “Run Cal Cycle” button. The analyzer will perform the calibration sweep.

APPENDIX C. CALIBRATION PROCEDURES.

m. After the calibration sweep is complete close the Configuration window to view the calibration. Figure C-7 illustrates a balun calibration curve.

n. Open the Configuration tab and press Save Calibration.

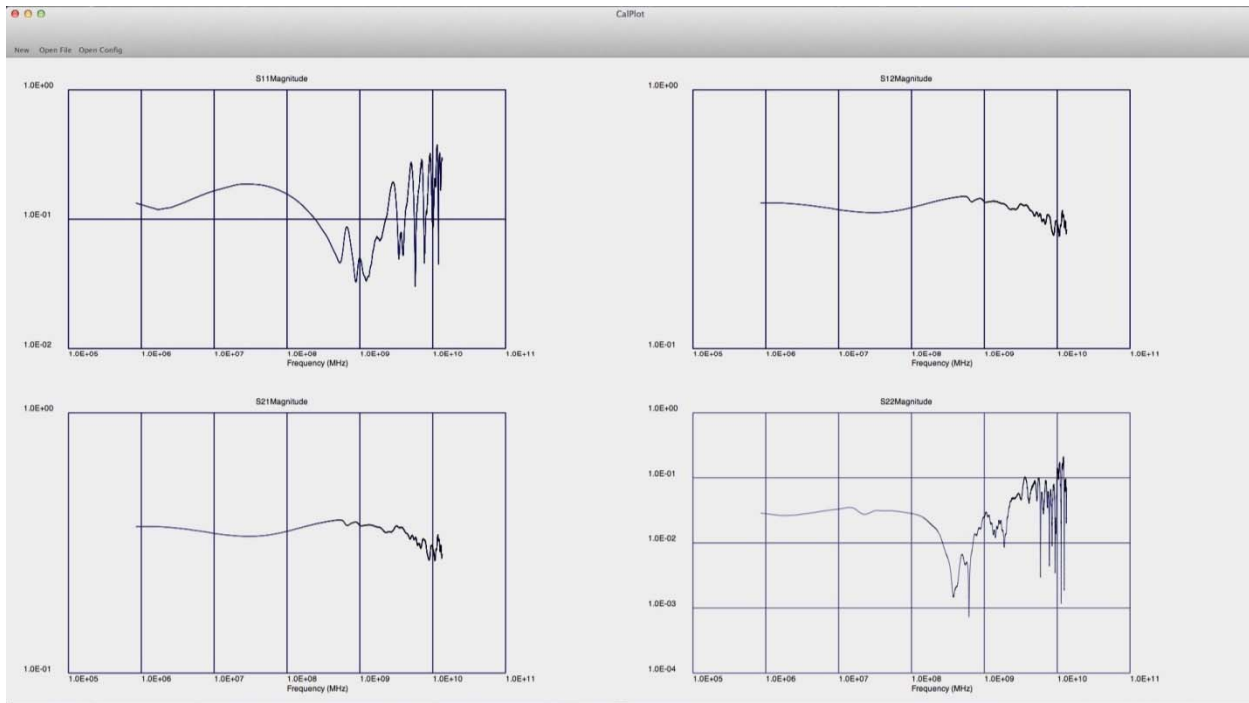

Figure C-7. Balun calibration for DMB-6C.

C.3.4 Programmable Attenuators Calibration Procedure.

Each programmable attenuator chassis contains four independently-controlled programmable attenuators. The calibration files should be created with the unit set to 0 dB.

- a. Startup the server workstation.
- b. Power on the Network Analyzer and allow it to warm up for 30 minutes.
- c. Setup the Network Analyzer parameters as follows:

Number of points: 4096
Start Frequency: 300 kHz
Stop Frequency: 13.5 GHz
Power Level: 0 dBm
Resolution BW: 1000 Hz

APPENDIX C. CALIBRATION PROCEDURES.

- d. Perform an eCal calibration to calibrate the network analyzer and the cables used to connect the network analyzer to the attenuator. Figure C-1 illustrates this configuration.
- e. Remove the E-Cal module and replace with the attenuator, connect Port 1 of the analyzer to the input of the attenuator channel 1 and Port 2 to the output.
- f. Start the Calibration Application and select the New tab. Figure C-3 illustrates the New Cal File window that should open.
 - g. In the New Calibration File window enter the following information in each field and press Accept when finished:

Name: HPA Serial Number
Class select HPA
Type: HPA
- h. Select the Open Config tab.
- i. Enter the IP address for the Network Analyzer to be used and Analyzer Model information and press Connect.
- j. In the Calibration Application window enter the following Sweep Setup calibration parameters:

Start Frequency	300 e+3
End Frequency	13.5 e+9
Power	0
Number of Points	4096
- k. Press the “Run Cal Cycle” button. The analyzer will perform the calibration sweep.
- l. After the calibration sweep is complete close the Configuration window to view the calibration. Figure C-8 illustrates a programmable attenuator calibration curve.
- m. Open the Configuration tab and press Save Calibration.

APPENDIX C. CALIBRATION PROCEDURES.

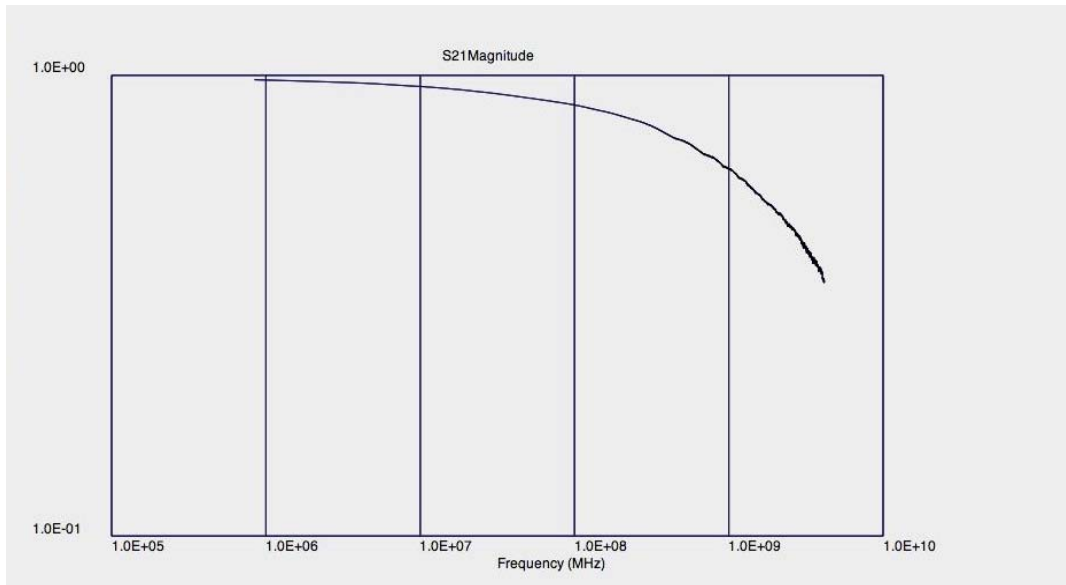

Figure C-8. Programmable attenuator calibration.

(This page is intentionally blank.)

APPENDIX D. GLOSSARY.

1. Electric Field – A fundamental component of RF electromagnetic waves, which exists when there is a voltage potential difference between two points in space.
2. Field Strength – The magnitude of the electric field, in V/m, or magnetic field, in amps/meter (A/m).
3. Magnetic Field – A field of force produced by a changing electric field.
4. Microwave or RF Sources – Any source of radiation in this region of the electromagnetic spectrum: radars, microwave ovens, diathermy units or communication facilities.

TOP 01-2-624
6 July 2015

(This page is intentionally blank.)

APPENDIX E. ABBREVIATIONS.

ADSS	U.S. Army Test and Evaluation Command Decision Support System
AR	Army Regulation
CFT	Continuous Fourier Transform
DA Pam	Department of the Army Pamphlet
dB	decibel
DOD	Department of Defense
DODI	Department of Defense Instruction
E-Cal	electronic calibration
E-Field	electric field
EM	electromagnetic
FFT	Fast Fourier Transform
GHz	Gigahertz
H-Field	magnetic field
HPM	High Power Microwave
Hz	Hertz
IEEE	Institute of Electrical and Electronics Engineers
IFFT	Inverse Fast Fourier Transform
IP	internet protocol
km	kilometer
kV/m	kilovolts per meter
MHz	Megahertz
MIL HDBK	Military Handbook
MIL-STD	Military Standard
NIST	National Institute of Standards and Technology

APPENDIX E. ABBREVIATIONS.

PEL	Permissible Exposure Limits
RF	radio frequency
TO	Test Officer
TOP	Test Operations Procedure
WBS	work-breakdown structure
WSMR	White Sands Missile Range

APPENDIX F. REFERENCES.

1. MIL-STD-464C, Electromagnetic Environmental Effects Requirements For Systems, 1 December 2010.
2. Directed Energy Test & Evaluation Capability Sensor Suite Software Algorithm Manual, 8 December 2006.
3. DODI 6055.11, Protecting Personnel from Electromagnetic Fields, 19 August 2009.
4. IEEE C95.1-2005, Standard for Safety Levels with Respect to Human Exposure to RF Electromagnetic Fields, 3kHz to 300GHz, 19 April 2006.
5. IEEE C95.1-2345, Standard for Military Workplaces-Force Health Protection Regarding Personnel Exposure to Electric, Magnetic, and Electromagnetic Fields, 0 Hz to 300GHz, 16 May 2014.

REFERENCES FOR INFORMATION ONLY

- a. Directed Energy Test & Evaluation Capability Sensor Suite Maintenance Manual, 14 June 2008.
- b. MIL-STD-882E, Department of Defense Standard Practice for System Safety, 11 May 2012.
- c. TOP 01-2-511A, Electromagnetic Environmental Effects System Testing, 20 November 2013.
- d. Army Regulation (AR) 70-75, Survivability of Army Personnel and Materiel, 2 May 2005.
- e. AR 73-1, Test and Evaluation Policy, 1 August 2006.
- f. DA Pam 73-1, Test and Evaluation in Support of Systems Acquisition, 30 May 2003.

TOP 01-2-624
6 July 2015

(This page is intentionally blank.)

APPENDIX G. APPROVAL AUTHORITY.

CSTE-TM

6 July 2015

MEMORANDUM FOR

Commanders, All Test Centers
Technical Directors, All Test Centers
Directors, U.S. Army Evaluation Center
Commander, U.S. Army Operational Test Command

SUBJECT: Test Operations Procedure (TOP) 01-2-624, High Power Microwave (HPM) Testing, Approved for Publication

1. TOP 01-2-624, High Power Microwave (HPM) Testing, has been reviewed by the U.S. Army Test and Evaluation Command (ATEC) Test Centers, the U.S. Army Operational Test Command, and the U.S. Army Evaluation Center. All comments received during the formal coordination period have been adjudicated by the preparing agency. The scope of the document is as follows:

This TOP provides guidance in preparing and conducting HPM testing and verification of Army and/or Department of Defense systems both new and modified. This document adheres to requirements stated in Military Standard-464C "Electromagnetic Environmental Effects Requirement for Systems".

2. This document is approved for publication and has been posted to the Reference Library of the ATEC Vision Digital Library System (VDLS). The VDLS website can be accessed at <https://vdl.s.atc.army.mil/>.

3. Comments, suggestions, or questions on this document should be addressed to U.S. Army Test and Evaluation Command (CSTE-TM), 2202 Aberdeen Boulevard-Third Floor, Aberdeen Proving Ground, MD 21005-5001; or e-mailed to usarmy.apg.atec.mbx.atec-standards@mail.mil.

ZWIEBEL.MICHAEL.J.1229197289
EL.J.1229197289

Digitally signed by
ZWIEBEL.MICHAEL.J.1229197289
DN: cn=US, o=U.S. Government, ou=DoD,
ou=PTO, ou=USA,
cn=ZWIEBEL.MICHAEL.J.1229197289
Date: 2015.07.06 11:13:31 -0400

MICHAEL J. ZWIEBEL
Director, Test Management Directorate (G9)

TOP 01-2-624
6 July 2015

(This page is intentionally blank.)

Forward comments, recommended changes, or any pertinent data which may be of use in improving this publication to the following address: Range Infrastructure Division (CSTE-TM), U.S. Army Test and Evaluation Command, 2202 Aberdeen Boulevard, Aberdeen Proving Ground, Maryland 21005-5001. Technical information may be obtained from the preparing activity: Survivability, Vulnerability, & Assessment Directorate (TEDT-WSV-E), U.S. Army White Sands Missile Range, NM 88002-5178. Additional copies are available from the Defense Technical Information Center, 8725 John J. Kingman Road, STE 0944, Fort Belvoir, VA 22060-6218. This document is identified by the accession number (AD No.) printed on the first page.