

Center for Southeastern Tropical Advanced Remote Sensing (CSTARS)

Hans C. Graber
RSMAS - Applied Marine Physics
University of Miami
4600 Rickenbacker Causeway
Miami, FL 33149-1098, USA
phone: (305) 361-4935 fax: (305) 361-4701 email: hgrab@rsmas.miami.edu

Timothy H. Dixon
RSMAS – Marine Geology and Geophysics
University of Miami
4600 Rickenbacker Causeway
Miami, FL 33149-1098 , USA
phone: (305) 361-4660 fax: (305) 361-4632 email: tdixon@rsmas.miami.edu

Robert H. Evans
RSMAS – Meteorology and Physical Oceanography
University of Miami
4600 Rickenbacker Causeway
Miami, FL 33149-1098, USA
phone: (305) 361-4885 fax: (305) 361-4057 email: revans@rsmas.miami.edu

Award Number: N00014-00-1-0875

LONG-TERM GOAL

We wish to establish a high capability satellite data reception and analysis facility for environmental monitoring in the southeastern US, Gulf of Mexico, Caribbean Basin and Equatorial Atlantic. CSTARS will provide a variety of satellite data and support for scientific research in land, atmosphere, ice and ocean sciences, as well as applied applications in the fields of environmental monitoring, natural hazard assessment, civil defense and defense tactical applications.

SCIENTIFIC OBJECTIVES

To achieve these goals we are developing a high capability receiving and analysis facility for X-band satellite data with a subsequent enhanced capability that would include lower frequency L- and S-band reception. Key priorities in the system design will be high reliability data reception to low elevation angles and rapid data access for all scientific, civilian and defense tactical users.

The specific scientific objectives of this proposed project are, but not limited to air-sea interaction and ocean dynamics:

1. To explore the further use of SAR imagery for retrieval of high-resolution synoptic wind fields with special emphasis on tropical storms.

Report Documentation Page

Form Approved
OMB No. 0704-0188

Public reporting burden for the collection of information is estimated to average 1 hour per response, including the time for reviewing instructions, searching existing data sources, gathering and maintaining the data needed, and completing and reviewing the collection of information. Send comments regarding this burden estimate or any other aspect of this collection of information, including suggestions for reducing this burden, to Washington Headquarters Services, Directorate for Information Operations and Reports, 1215 Jefferson Davis Highway, Suite 1204, Arlington VA 22202-4302. Respondents should be aware that notwithstanding any other provision of law, no person shall be subject to a penalty for failing to comply with a collection of information if it does not display a currently valid OMB control number.

1. REPORT DATE 30 SEP 2001	2. REPORT TYPE	3. DATES COVERED			
4. TITLE AND SUBTITLE Center for Southeastern Tropical Advanced Remote Sensing (CSTARS)		5a. CONTRACT NUMBER			
		5b. GRANT NUMBER			
		5c. PROGRAM ELEMENT NUMBER			
6. AUTHOR(S)		5d. PROJECT NUMBER			
		5e. TASK NUMBER			
		5f. WORK UNIT NUMBER			
7. PERFORMING ORGANIZATION NAME(S) AND ADDRESS(ES) University of Miami,,4600 Rickenbacker Causeway,,Miami,,FL, 33149		8. PERFORMING ORGANIZATION REPORT NUMBER			
9. SPONSORING/MONITORING AGENCY NAME(S) AND ADDRESS(ES)		10. SPONSOR/MONITOR'S ACRONYM(S)			
		11. SPONSOR/MONITOR'S REPORT NUMBER(S)			
12. DISTRIBUTION/AVAILABILITY STATEMENT Approved for public release; distribution unlimited.					
13. SUPPLEMENTARY NOTES The original document contains color images.					
14. ABSTRACT					
15. SUBJECT TERMS					
16. SECURITY CLASSIFICATION OF:			17. LIMITATION OF ABSTRACT	18. NUMBER OF PAGES 6	19a. NAME OF RESPONSIBLE PERSON
a. REPORT unclassified	b. ABSTRACT unclassified	c. THIS PAGE unclassified			

2. To examine the surface roughness, wave breaking and directional distribution of the wave field in tropical and extra-tropical storm systems.
3. To explore and quantify mesoscale flow patterns in synoptic and tropical lows.
4. To study in more detail the morphology of hurricanes especially when coupled with information about cloud patterns and precipitation from other sensors.
5. To develop algorithms for improved detection of ships and their location, size and type as well as speed and direction characteristics.
6. To examine ocean features such as fronts, currents and eddies and combine with measurements of long-range shore-based high-frequency Doppler radars.
7. To study a variety of applications on coastal and river flooding and shoreline changes as well as monitoring of water resources and vegetation and hazards arising from volcanoes.

APPROACH

The new satellite data reception and analysis facility will be located on the former Navy VLBI site at Richmond, in southern Miami-Dade County, Florida, and will be integrated via high speed internet with the university's existing satellite data reception capability at the Rosenstiel School for Marine and Atmospheric Science (RSMAS) campus. It is our intention to make this facility a leading center for environmental remote sensing applications in the southeastern US.

CSTARS applications will be quite diverse. They will include a wide range of scientific applications in land, atmosphere, ice and ocean sciences, as well as more applied applications in the fields of environmental monitoring, natural hazard assessment, civil defense and defense tactical applications. High reliability data reception to low elevation angles (~3 degrees above the local horizon) and rapid data access for all scientific and other civilian users will be key priorities in the system design. CSTARS will initially operate with dual antennas at X-band (~8 GHz frequency), and will be capable of receiving data from a wide variety of low-Earth orbiting satellite (LEOS) systems. Initial operational capability will focus on RADARSAT and SPOT, but will eventually include ERS-2, LANDSAT, AVHRR, ENVISAT, SSMI and additional sensors on NASA's EOS platforms and Seawinds, the Navy's WINDSAT, as well as the Japanese satellites ALOS and ADEOS-II. Subsequent capability may also include lower frequency L- and S-band reception. The facility will be available to support a variety of scientific missions.

WORK COMPLETED

1. Twenty-two vendors from three countries responded to our request for proposal (RFP). Three serious bids were sent to the University of Miami. All bids were evaluated and were deemed capable to build the basic system required of Phase 1 for CSTARS.
2. Vexcel, Inc. was selected by the University of Miami at the beginning of October to build the basic system for CSTARS.

3. Site preparation and infra-structure work is progressing.

RESULTS

The CSTARTS facility will consist of three components: Ingest Archive System (IAS); Product Generation System (PGS); Data Exploitation System (DES). A schematic diagram of the CSTARTS system is shown in Figure 1. The facility is based on dual antennas for redundancy and conflict resolution.

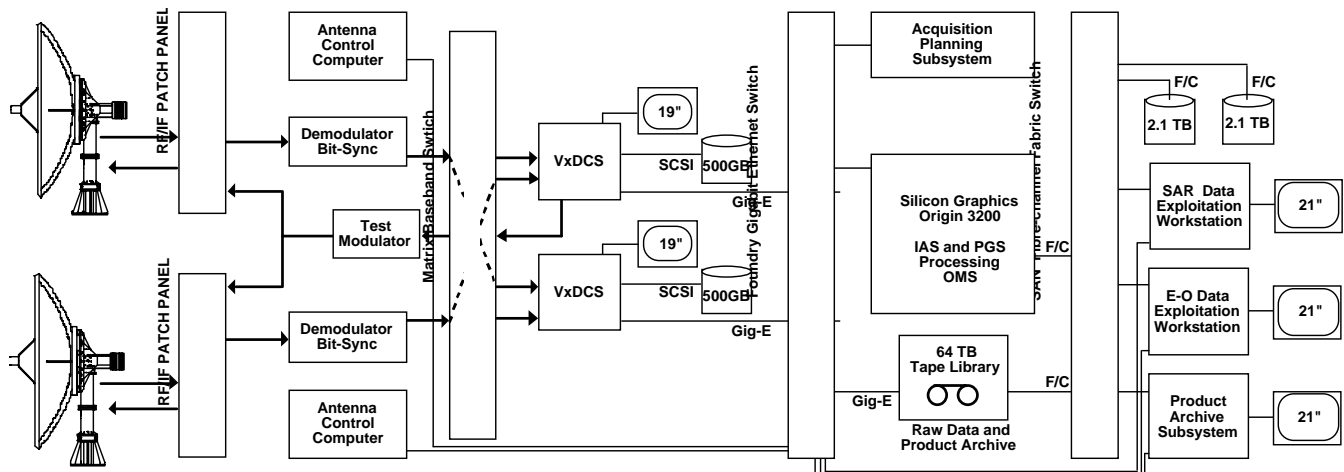

Figure 1: Block diagram of basic system for CSTARTS facility.

The CSTARTS ground station will consist of three systems:

- Ingest Archive System
- Product Generation System
- Data Exploitation System

1. The Ingest Archive System (IAS) will have the following components:

- Two Viasat Communications 11.28m X-Band Antenna Systems including:
 - 11.28m X-band Antenna and Pedestal
 - Tracking and Control Subsystem
 - R/F Conversion Subsystem
 - Fiber-optic IFL

2. The Product Generation System (PGS) will have the following components:

- The processing system is an 8-processor Origin 3200 computer with a double-bandwidth fibre-channel controller. The following subsystems are hosted on the Origin 3200:

- Level 1.5 Processing Subsystem
- Level 2 Processing Subsystem
- Geocoding Processing Subsystem
- Interferometric Preprocessing Subsystem
- Operations Management Subsystem
- Processing subsystem on Silicon Graphics Octane2 for:
 - Product Archive Subsystem
 - Catalog Order Subsystem

3. The Data Exploitation System (DES) will have the following components:

- SAR and Electro-Optical Exploitation System includes software for:
 - Interferometric DEM creation for SAR
 - Interferometric change detection for SAR
 - DEM modeling and enhancement for SAR
 - DEM Generation from Stereo SAR
 - DEM Generation for electro-optical sensors
 - Image processing and enhancement for electro-optical sensors

IMPACT/APPLICATION

The CSTARTS facility will exploit the frequent SAR coverage of Florida. In particular, CSTARTS will make a significant contribution to state and local response in hurricane and flood emergencies. By rapidly providing state and local officials with up-to-date, high-resolution, day or night images of affected areas and by providing quantitative flood extent and qualitative flood and wind damage information, the new system will greatly improve the efficiency of emergency response and relief efforts after natural disasters.

CSTARTS will give state officials and researchers a cost-effective method for regional monitoring of environmental hazard and will provide water managers and scientists synoptic images of the entire Everglades watershed. This information will allow near-real time monitoring of water level and hydroperiod, will allow a far better understanding of hydrologic cycle and ecosystem function, and will enable more accurate prediction and management of water availability.

TRANSITIONS

None yet.

RELATED PROJECTS

National Oceanographic Partnership Program (NOPP) project on “Real-Time Forecasting of Winds, Waves and Surge in Tropical Cyclones”. This project will utilize SAR-derived wind speed and

morphology of hurricanes to specify the small-scale variability of the wind field. These fields will be used to initialize high-resolution wind fields to force ocean wave and storm surge models.