



# PROCEEDINGS OF THE ELEVENTH ANNUAL ACQUISITION RESEARCH SYMPOSIUM

---

## WEDNESDAY SESSIONS VOLUME I

System Dynamics and Management Science Approaches  
Toward Increasing Acquisition Process Efficiency

Joachim Block, UniBwM  
Heinrich Buch, UniBwM  
Bo Hu, UniBwM  
Armin Leopold, UniBwM  
Stefan Pickl, UniBwM

**Published April 30, 2014**

Approved for public release; distribution is unlimited.

Prepared for the Naval Postgraduate School, Monterey, CA 93943.



# Report Documentation Page

Form Approved  
OMB No. 0704-0188

Public reporting burden for the collection of information is estimated to average 1 hour per response, including the time for reviewing instructions, searching existing data sources, gathering and maintaining the data needed, and completing and reviewing the collection of information. Send comments regarding this burden estimate or any other aspect of this collection of information, including suggestions for reducing this burden, to Washington Headquarters Services, Directorate for Information Operations and Reports, 1215 Jefferson Davis Highway, Suite 1204, Arlington VA 22202-4302. Respondents should be aware that notwithstanding any other provision of law, no person shall be subject to a penalty for failing to comply with a collection of information if it does not display a currently valid OMB control number.

1. REPORT DATE <b>30 APR 2014</b>		2. REPORT TYPE		3. DATES COVERED <b>00-00-2014 to 00-00-2014</b>	
4. TITLE AND SUBTITLE <b>System Dynamics and Management Science Approaches Toward Increasing Acquisition Process Efficiency</b>				5a. CONTRACT NUMBER	
				5b. GRANT NUMBER	
				5c. PROGRAM ELEMENT NUMBER	
6. AUTHOR(S)				5d. PROJECT NUMBER	
				5e. TASK NUMBER	
				5f. WORK UNIT NUMBER	
7. PERFORMING ORGANIZATION NAME(S) AND ADDRESS(ES) <b>Universit??t der Bundeswehr M??nchen (UniBwM), Werner-Heisenberg-Weg 39, 85577 Neubiberg,</b>				8. PERFORMING ORGANIZATION REPORT NUMBER	
9. SPONSORING/MONITORING AGENCY NAME(S) AND ADDRESS(ES)				10. SPONSOR/MONITOR'S ACRONYM(S)	
				11. SPONSOR/MONITOR'S REPORT NUMBER(S)	
12. DISTRIBUTION/AVAILABILITY STATEMENT <b>Approved for public release; distribution unlimited</b>					
13. SUPPLEMENTARY NOTES					
14. ABSTRACT <b>Contracting has a significant impact on the acquisition process efficiency, especially in the context of so-called public???private partnership (PPP). Improper contracts may cause significant delay and additional costs in project execution due to opportunistic behavior of private-sector suppliers. We present a system dynamics model combined with a web based management cockpit for project contracting and interactive decision support which can be used to train project purchasers showing that carefully designed contracts help to keep the project on schedule and bring benefits to both the governmental entities and the privatesector suppliers.</b>					
15. SUBJECT TERMS					
16. SECURITY CLASSIFICATION OF:			17. LIMITATION OF ABSTRACT <b>Same as Report (SAR)</b>	18. NUMBER OF PAGES <b>51</b>	19a. NAME OF RESPONSIBLE PERSON
a. REPORT <b>unclassified</b>	b. ABSTRACT <b>unclassified</b>	c. THIS PAGE <b>unclassified</b>			

The research presented in this report was supported by the Acquisition Research Program of the Graduate School of Business & Public Policy at the Naval Postgraduate School.

To request defense acquisition research, to become a research sponsor, or to print additional copies of reports, please contact any of the staff listed on the Acquisition Research Program website ([www.acquisitionresearch.net](http://www.acquisitionresearch.net)).



ACQUISITION RESEARCH PROGRAM  
GRADUATE SCHOOL OF BUSINESS & PUBLIC POLICY  
NAVAL POSTGRADUATE SCHOOL

## Panel 9. Contract Design for Successful Public-Private Partnerships

---

Wednesday, May 14, 2014	
3:30 p.m. – 5:00 p.m.	<p><b>Chair: Fred Thompson</b>, Professor, Atkinson Graduate School of Management, Willamette University</p> <p><b><i>A New “Availability-Payment” Model for Pricing Performance-Based Logistics Contracts</i></b></p> <p>Amir KashaniPour, University of Maryland Xinyan Zhu, University of Maryland Peter Sandborn, University of Maryland Qingbin Cui, University of Maryland</p> <p><b><i>System Dynamics and Management Science Approaches Toward Increasing Acquisition Process Efficiency</i></b></p> <p>Joachim Block, UniBwM Heinrich Buch, UniBwM Bo Hu, UniBwM Armin Leopold, UniBwM Stefan Pickl, UniBwM</p> <p><b><i>The Construction of Defense Department Contracts in Thin Markets</i></b></p> <p>Trevor Brown, Ohio State University Yong Woon Kim, Ohio State University Alex Roberts, Ohio State University Daniel Albalade, University of Barcelona</p>



# System Dynamics and Management Science Approaches Toward Increasing Acquisition Process Efficiency

**Stefan Pickl**—studied mathematics, electrical engineering, and philosophy at TU Darmstadt and EPFL Lausanne from 1987–1993 (Dipl.-Ing. '93, Doctorate 1998 with award). Pickl's experience also includes the following: assistant professor at Cologne University; visiting professor at University of New Mexico (U.S.A.), University Graz (Austria), and University of California at Berkeley; visiting scientist at SANDIA, Los Alamos National Lab, Santa Fe Institute for Complex Systems, and MIT; associated with the Centre for the Advanced Study of Algorithms (USA), vice-chair of the EURO group "Experimental OR," chair of the advisory board of German Society for Operations Research, International Best Paper Awards; Foundation of COMTESSA (Core Competence Center for Operations Research, Management–Strategic Studies, Safety & Security Alliance); and Chair for Operations Research at University of Federal Armed Forces Munich.

**Joachim Block**—holds a management position in a German higher federal authority. He joined public service after his studies of computer science at University of Passau, Germany. He is a member of the IEEE and Mensa in Germany (MinD). At present, he is working on his PhD at COMTESSA, an institute at the University of Federal Armed Forces Munich, Germany. His main interests lie within decision support systems, systems theory, and strategic management, especially in public sector organizations.

**Heinrich Buch**—is a retired Colonel (General Staff) German Army and former director of Operations Research of the Bundeswehr. His academic background (diploma) is in political science, history, and law. He is a former director of minority staff Armed Services of Der Deutsche Bundestag with many publications in international politics. He is a SME for decision-making processes and CD&E and is senior advisor for Professor Pickl and his institute COMTESSA.

**Bo Hu**—is professor of management specializing in information systems at Universität der Bundeswehr München, Germany, and visiting professor at Universität Graz. His main fields of research are collaboration and decision support processes and systems in the areas of sustainable business and social development. He studied at Technische Universität München and holds a PhD in physics from Universität Erlangen-Nürnberg, Germany.

**Armin Leopold**—holds a Master of Environmental System Science from University Graz, Austria. In addition, he studied Master International Management in Kalmar, Sweden. Since 2010 he has been a scientific assistant of the Chair of Operations Research at Universität der Bundeswehr München while writing his PhD in Leiden, Netherlands.

## Abstract

Contracting has a significant impact on the acquisition process efficiency, especially in the context of so-called public–private partnership (PPP). Improper contracts may cause significant delay and additional costs in project execution due to opportunistic behavior of private-sector suppliers. We present a system dynamics model combined with a web based management cockpit for project contracting and interactive decision support which can be used to train project purchasers showing that carefully designed contracts help to keep the project on schedule and bring benefits to both the governmental entities and the private-sector suppliers.

## Introduction

Delays in a public–private partnership project cause a two-fold disadvantages for the contracting authority. Firstly, the planned features often are not available during the period of delay. Secondly, in many cases, due to the delay the features are partly already out of date when they are put into use. However, improvement of the project contracting process may have a significant contribution to reduce project delays, additional costs and improve outcome of the project.



In our research we want to analyze how project contracts that include carefully designed timely penalties may help to keep a project on track and within the planned timeline. The proposed system dynamics model in combination with the web based management cockpit for project contracting and interactive decision support is developed at the Universität der Bundeswehr München (Germany) and shall be used for teaching project contracting in the future.

In this paper we start with a literature review to examine three related research issues: public–private partnership, opportunistic behavior and contracting, as well as project contracting from the view of system dynamics. After that, we describe our concept development using a web based management cockpit with an underlying system dynamics model for project contracting and interactive decision support, along with some preliminary results. Thereby, a better understanding of the problem and the relation between the contracting authority on the one side and the private-sector project supplier on the other side can be achieved.

## **Literature Review**

### ***Public–Private Partnership***

The evolution of the New Public Management (NPM) idea in the 1980s has shifted the emphasis in the public sector away from stress on process to a stress on output (Hood, 1995). One concept within NPM concerns the use of public–private partnerships (PPPs) in order to offer infrastructure and services to the public efficiently. The interest of many nations to take use of PPPs is attributed among others to faster delivery and reduced whole life costs of public infrastructure and services, improved quality, and the generation of additional revenues (European Commission, 2003). Especially in a time of financial shortfalls and cuts in public budgets together with increasing infrastructure costs, PPPs become a popular option for many nations (Winch, 2012).



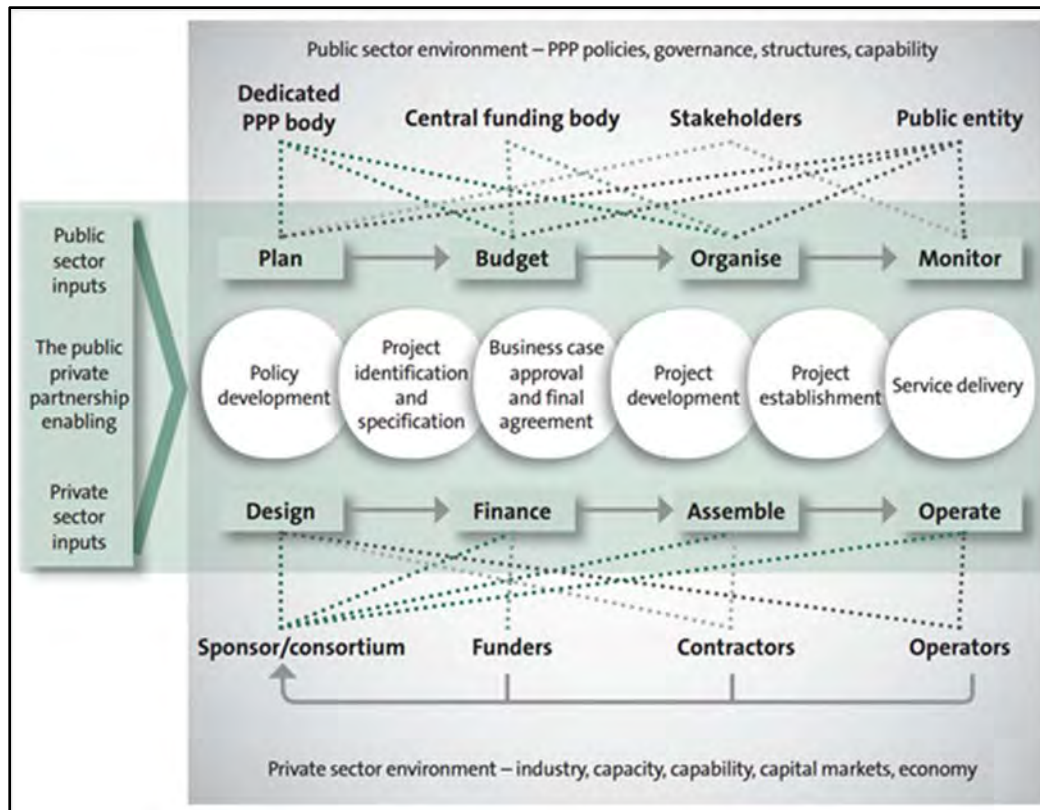

**Figure 1. The Public-Private Partnership Environment**  
(Provost, 2011)

Even though there is no universally accepted definition of PPP (Khanom, 2009), this kind of partnership lies somewhere between delivery of infrastructure and services by public sector organizations and total privatization of these tasks. The National Council for Public-Private Partnerships explains the term PPP as means of utilizing private-sector resources in a way that is a blend of outsourcing and privatization (National Council, 2002, p. 4). Iossa et al. describe public-private partnership from the infrastructure point of view as a long-term contractual arrangement between the public sector and the private sector in which the private sector is responsible for significant aspects of the building and operation of an infrastructure for the delivery of public services (Iossa, 2007, p. 3). More generally speaking, a “PPP is a partnership between the public sector and the private sector for the purpose of delivering a project or a service traditionally delivered by the public sector” (European Commission, 2003, p. 16). PPP may involve design, construction, financing, operation and maintenance of public infrastructure, facilities, or the operation of services to meet public needs. The UK for example has a large body of experience in funding public infrastructure with private capital, the so called Private Finance Initiative (PFI) (National Audit Office, 2011). Figure 1 “provides a general overview of the public and private sector participants and activities that can surround a PPP project or programme. It shows each sector’s inputs into the process from policy development to service delivery” (Provost, 2011).

Resources, risks, and rewards are shared between public and private entities by—mostly long-term—contracts (National Council, 2009). This allows each party to do what it does best. While private entities are responsible for operational aspects, the public sector has to set its focus on planning, contracting and monitoring (European Commission, 2003). As a result, sufficient commercial skills are indispensable for public entities to manage PPP

projects, which in most cases are complex projects, successfully (National Audit Office, 2009). What happens when there is a lack of these skills is illustrated in the following example.

Since the 1980s, the mayor of Farum, Denmark has followed an active strategy relying on contracting out and, later, PPPs for delivering various public services. In 2002 the issue about the PPP contract for construction of the soccer stadium and the sports arena, and inadequate money spending led to a local governmental scandal and the mayor's leave. The main reason for the failure of PPP in this case was the fact that the structure of the contractual governance scheme in Farum was too complex for the mayor to oversee the resources (Greve, 2002, p. 2).

Setting up adequate contracts (a "multidimensional model for PPP contracting" can be found in Zarco-Jasso, 2005) by which risks are transferred from the public to the private sector is a critical success factor for PPP projects (Daly, 2004). To do this, it is essential for public officials to understand how commercial levers work (George, 2009). Without such skills the likelihood of a less than optimal contractual outcome is significantly increased (Campbell, 2011).

### **Opportunistic Behavior and Contracting**

Regarding the regulatory and institutional framework, the quality of contract enforceability and governance are a critical factor affecting PPP agreements (Iossa, 2007, p. 6). Aspects of the contract design, such as the *risk allocation* or the payment mechanism, significantly affect the PPP outcomes (Iossa, 2007, p. 7). The sheer complexity of PPP contracts makes opportunistic behavior a key issue for the success of a PPP project. A crucial point is the opportunism which plays an important role for interparty collaboration in every project. On the one hand, opportunism increases transaction costs in repeated exchange mainly because of the crucial fact that covert behavior seeking unilateral gains are difficult to observe and to verify. On the other hand, opportunism can be seen as a significant obstacle to fostering confidence in partner cooperation, and consequently the risk of opportunism may escalate interparty conflicts (Luo, 2007, p. 857).

Opportunistic behavior can be generally described as taking the opportunity to manage earnings in order to maximize their own utilities at the expense of the contracting parties and stakeholders (Sun, 2008, p. 407). In details, opportunistic behavior can be explained as the usage of information asymmetry between outsiders and insiders to maximize their utility in dealing with compensation contracts, debt contracts and regulations. Furthermore, investors are thereby misled by the unreliable information reported (Sun, 2008, p. 410). Consequently, it can be said that opportunism represents a significant obstacle to fostering confidence in partner cooperation, and the risk of opportunism escalates interparty conflicts. In other words, opportunistic parties do their own thing and emphasize their own interests, hence weakening the basic foundation for collaboration (Luo, 2007, p. 857).

Especially a lack of *quality control* during the project and additional institutional setting allows for opportunistic behavior, increases the likelihood of dealing with inadequate service suppliers, and represents a performance risk for the client (see, e.g., Glückler, 2003, p. 289). Therefore, one successful way to reduce this opportunistic behavior is personal experience that evolves from interaction between clients and consultants which becomes most important in reducing uncertainty and controlling for opportunistic behavior (Glückler, 2003, p. 270).

As mentioned at the beginning of Section 1, delays in a public-private partnership project cause a two-fold disadvantage for the contracting authority. In addition, Wood



identifies schedule delays as a cost driver of major defense programs (Wood, 2012). A central task of a properly concluded contract must thus include a functional *project schedule management*.

Bernheim and Whinston developed a formal model and showed that making the contract more explicit may further encourage opportunistic behavior surrounding actions that cannot be specified within contracts (Bernheim, 1998, p. 921). Nevertheless, the capacity for contracts to adequately safeguard relationship-specific investments against opportunistic behavior by a contractual partner is limited (Mayer, 2004, p. 396).

## **Project Contracting and System Dynamics**

The complexity inherent in many projects exceeds human imagination by far. Although among the most important activities in modern society, *large-scale* and *long-term* projects are one of the least organized activities. Therefore, it is no wonder that these kinds of projects typically experience additional costs, delays and quality problems. Over several years Cooper and Mullen analyzed some major projects in different industries (Cooper, 1993). They reported that commercial software projects are more expensive by about 140% than planned and lasted about 190% longer as originally scheduled. For military projects, his analysis reported that there were even 310% additional costs and 460% delay. Another study of transportation infrastructure projects reports a cost overrun in nine out of 10 projects (Flyvbjerg, 2002). Rail projects, fixed-links projects (bridges and tunnels), and road projects experience an average cost overrun of 28%. According to Flyvbjerg, “the private sector, the public sector, and private/public sector partnerships have a dismal record of delivering on large infrastructure cost and performance promises” (Flyvbjerg, 2009, p. 170). Some “famous” examples include the implementation of a tolling system for German motorways (Toll Collect), the construction of the Eurotunnel connecting France and the UK, and the Sydney Opera house. Nowadays, the extreme delay and cost overrun of Berlin’s new airport BER (Niemeier, 2013) let classify this large scale infrastructure project as failed.

According to the Project Management Institute, a “project is a temporary endeavor undertaken to create a unique product, service, or result” (PMI, 2004, p. 5). With this definition in mind, every project has to keep the balance of “The Iron Triangle” (Atkinson, 1999): time, cost, and quality. In PPP projects the objectives of the project, the delivering date, and the price paid are fixed in a contract.



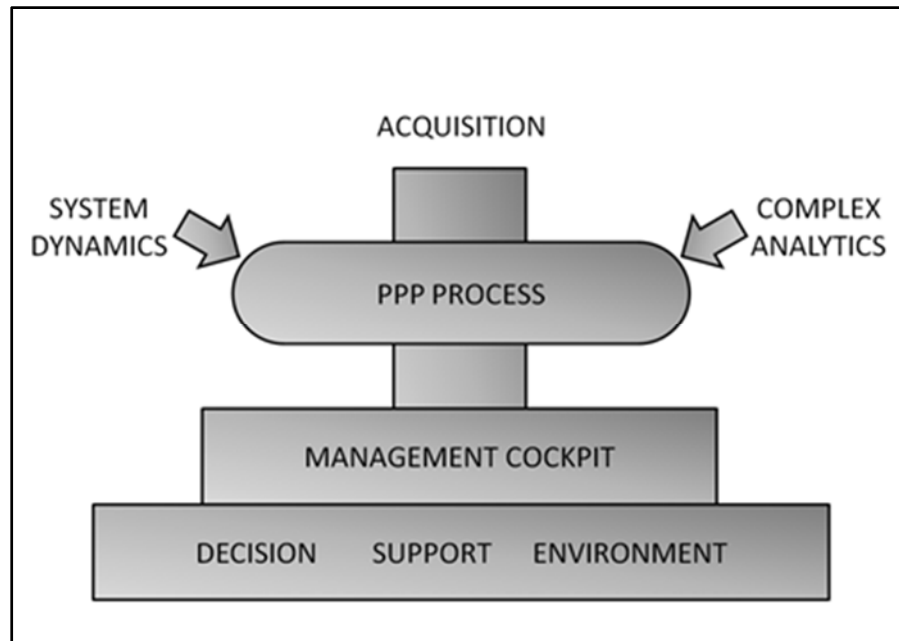

**Figure 2. PPP and System Dynamics—New Form of Decision Support**

The private partner, that is, the private supplier, is responsible for delivering the project objectives in accordance to the contract. He has to spend and assign resources, among others human resources, to best meet these objectives. To reduce complexity, large scale projects are usually divided into manageable deliverables in form of a so called work breakdown structure (see NASA, 2010). The elements in the work breakdown structure are sub-results and define the tasks which have to be fulfilled during the project execution. On the other hand, the public partner, that is, the contracting authority, has to reward the supplier for the contractual deliverables. The delivered results create a benefit for the public.

A key aspect for successful project delivery, that is on time, on budget, and on value, is to handle project complexity (Baccarini, 1996). The evolution of information technology provides methods and tools to support this task by modeling and simulation (Mizzel, 2007). One of the computer-aided modeling methods is system dynamics (Figure 2). Properly developed system dynamics models may provide decision support in the project development phase and the support in making decisions concerning the project schedule with a long-term focus on the realization (Lyneis, 2001, p. 241).

One of the strengths of system dynamics is the representation of the interdependencies within a project and the subsequent tracking of changes in the model. It can be said that system dynamics consists of one of the most developed plans for action, the optimal representation, analysis and detailed explanation of dynamics in complex technical systems as well as in entrepreneurial systems (Sterman, 1992, p. 6f.). Additional costs and delays can be detected early. System dynamics should be regarded as an additional method for decision support in project management to the existing, traditional project management methods. Especially when handling complex project dynamics, based on causal relationships, feedback loops, time delays and non-linearity, system dynamics can be regarded as a potential method (Sterman, 1992, p. 9).

### **Summary**

System dynamics modeling and simulation is an effective instrument to understand and to improve project contracting process efficiency in many ways. We propose to develop

a new approach via system dynamics model for project execution based on (Lyneis, 2001) and our previous research projects.

## Concept Development

### ***A Web Based Management Cockpit for Project Contracting***

As shown by previous studies, both accuracy of the mental model of the participants for a complex managerial task (Gary, 2005) and data presentation (Leopold-Wildburger, 2013) may influence the performance of an interactive decision process.

As discussed in the literature review, understanding opportunistic behavior during PPP acquisition and execution is a critical success factor for PPP projects. The right hand side of the causal loop diagram (CLD) depicted in Figure 3 illustrates how *understanding of opportunism* is embedded in a feedback loop. *Understanding of opportunism* influences positively the *quality of the PPP contract*. The better the *quality of contract* the fewer *opportunistic behavior* of the private partner is to be expected. In turn, *project outcome* will benefit. Following the link, *project outcome* impacts *project complexity*. The higher the former, the lower the latter is and vice versa. When the project is very complex, the *understanding of opportunism* suffers. On the other hand, a reduced *project complexity* simplifies *understanding of opportunism*. In addition, *project complexity* has a negative relationship to *quality of contract*.

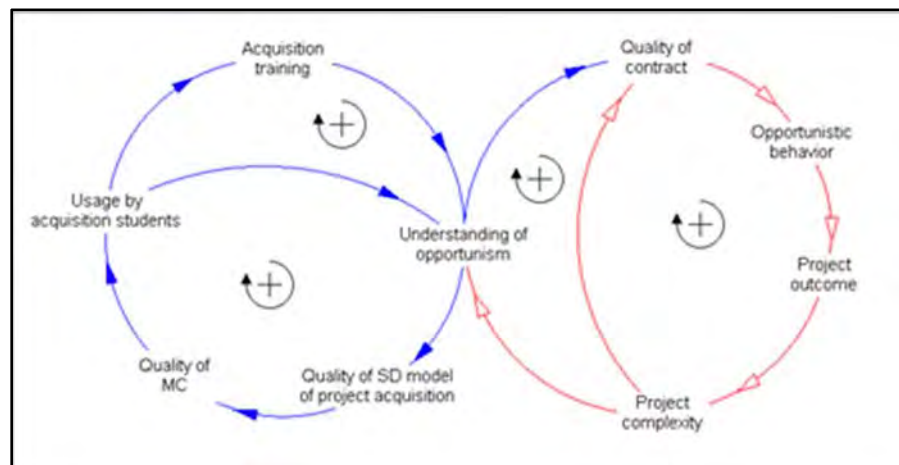

**Figure 3. A Causal Loop Diagram of Project Contracting and Management Cockpit**

Besides reducing project complexity, another solution does exist to increase the *understanding of opportunistic behavior*. This is can be seen on the left hand side of the CLD (Figure 3). A high *understanding of opportunism* results in a high *quality of SD model of project acquisition*. As a consequence, the *quality of the management cockpit (MC)* increases as well. A well designed and implemented management cockpit enhances the *usage by acquisition students*. This, in turn, impacts positively the *understanding of opportunism* directly and indirectly via a higher level of *acquisition training*. Therefore, to control the *understanding of opportunism* the design and implementation of an adequate management cockpit is key. A properly developed and accessible management cockpit should support both acquisition research and acquisition training.

Based on Hu (2011), we develop a prototype of a web based management cockpit for interactive project contracting. The system architecture of the whole platform which the prototype is embedded in is shown in Figure 4.

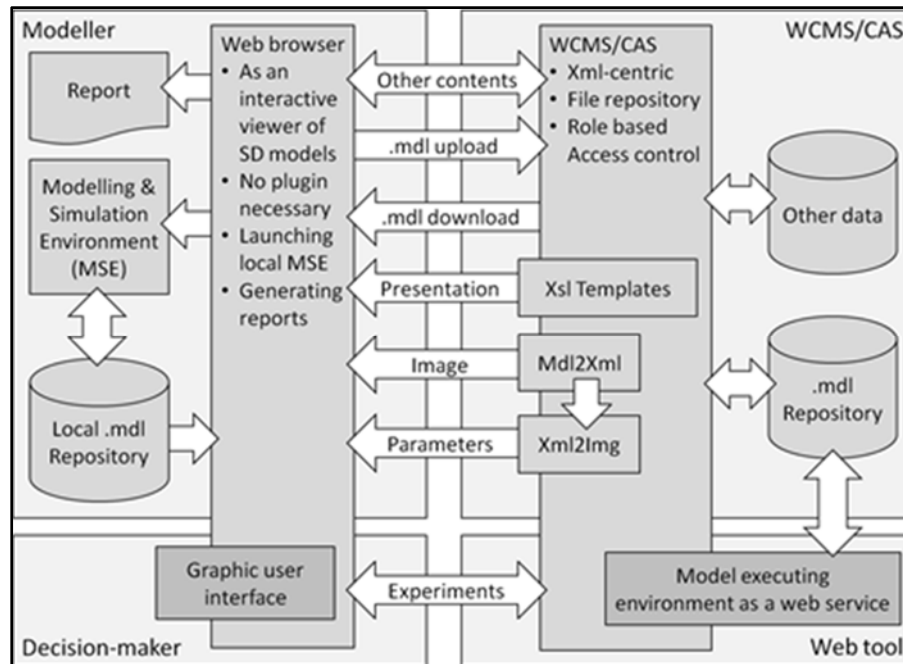

**Figure 4. System Architecture of the Collaborative Modeling and Experiment Platform**

The core element of our prototype is a system dynamics model. To be able to integrate the newest research results, the platform is designed in such a way that this model can be easily replaced by a new version or even another system dynamics model. A web based tool not only facilitates deployment but also enhances collaboration. Furthermore, such a tool helps to present data in a more understandable fashion and supports information management. Thereby, users are able to achieve better decisions (Roth, 2010).

To implement the web based management cockpit, we extend our specific system dynamics model by an accessible user interface. Students will be invited to use the management cockpit for interactive decision support on project contracting. By analyzing their results and experiences, we will gain new insights into opportunistic behavior during the acquisition and contraction phase of a PPP project.

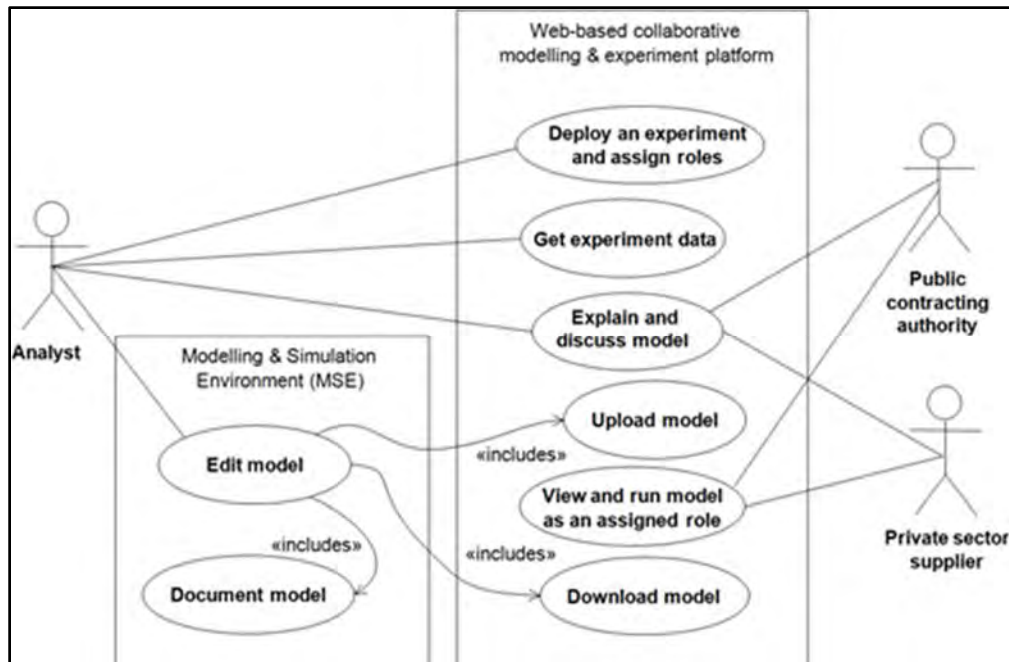
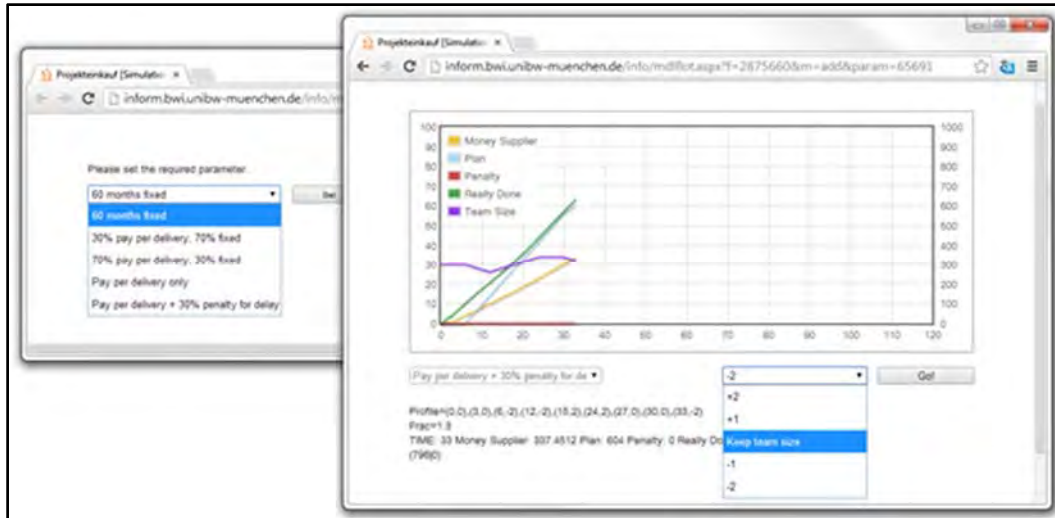

**Figure 5. Use Case Diagram for a Web Based Management Cockpit for Interactive Project Contracting**

The management cockpit will be tested by students in groups. Each of the participants will act as a project director. For several successive rounds, they will compete against each other under certain PPP contract conditions. Before the start of a test, participants will be provided with a detailed description of the PPP project itself, its contracting details and common rules. In addition, they will receive explicit instructions on how to use the web tool (Figure 5). Decision-makers of both public contracting authority and private sector supplier are involved.

The participants will take turns in acting from the public and from the private side. Main task for the public side will be setting of project contracting indicator values for the specified project. On the other side, as private contractors, the students will be required to pay attention on their profit and on fulfillment of the project. The focus is on necessary resources, that is, number of employees, for project implementation. Figure 6 shows the web user interface. During a simulated project, the management cockpit informs the participants interactively about project contract and execution details, including the following:

- *Money (earned by) Supplier*—measured in person · month
- Number of tasks to be executed according the project *Plan*—measured in person · month
- *Penalty*—measured in person · month
- Number of tasks which are *Really Done*—measured in person · month
- *Team Size*—measured in person



**Figure 6. Web User Interface. Left: Choosing Project Contracting Option by Public Contracting Authority; Right: Simulating Project Execution by Private Sector Supplier**

Our web based management cockpit for project contracting and interactive decision support offers the possibility to track participants' opportunistic behavior in decision-making during the progress of a simulated PPP project in a competitive environment as well as other key indicators for PPP projects. During a simulation run, all relevant data is stored for analysis in a preprocessing step. This allows identifying participants' learning and adaption processes as well as the identification of well working policies.

### Preliminary Results

As a first step, the students are all asked to play the role of a private sector contractor. Figures 7 and 8 show the results of project execution by two students. Four projects of two different contract terms have to be executed. The term options are given to them successively:

1. pay per delivery + 30% penalty for delay
2. pay per delivery only
3. pay per delivery + 30% penalty for delay
4. pay per delivery only

Notice that in our simulations a delay penalty (if any) may be already payable during the project execution. In the practice this makes necessary detailed project planning and monitoring processes on the side of public contracting authorities.

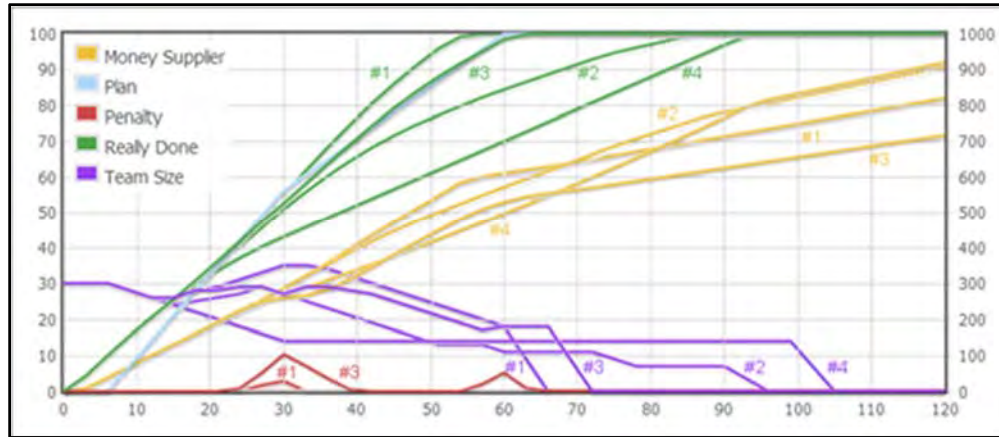

**Figure 7. Project Execution by Student A**

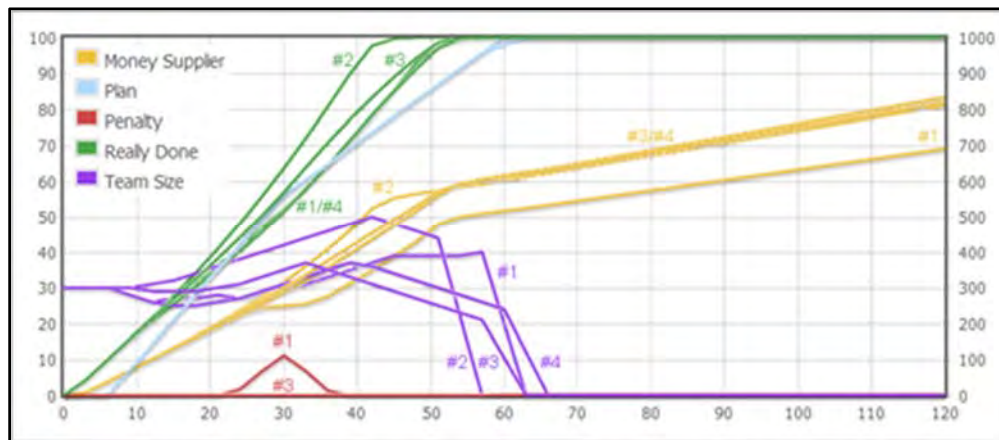
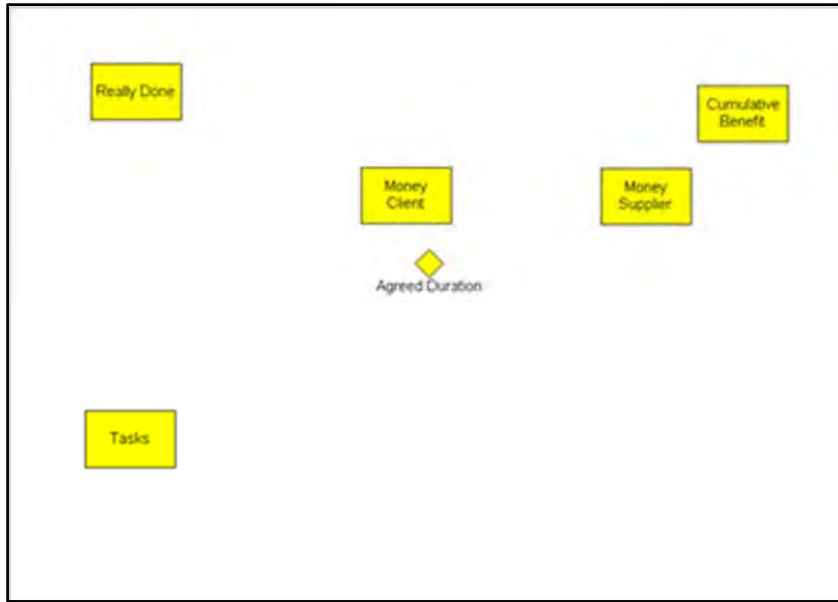

**Figure 8. Project Execution by Student B**

Comparing project execution #2 to #4 by both students, it is obviously that both students have learnt quickly that a smaller team size and thus a longer project duration is beneficial for project suppliers, if there is no danger of delay penalty. In other words, they learnt quickly to behave opportunistically. The difference between the execution #3 and #4, which is significant in the case of Student A and visible in the case of Student B, indicates the potential of a contract term of delay penalty to reduce the negative impact of such an opportunistic behavior.

### **Behind the Scenes: A System Dynamics Model of Project Contracting**

The system dynamics model which we have developed for our web based management cockpit for project contracting and interactive decision support does not only has a theoretical but also a more practical oriented background. Developing and deploying effective concepts and tools supporting contracting officials during their contracting and strategic planning activities is however an essential and long-term task.



**Figure 9. Parameter Set Describing a Project**

The current existing version of our model is capable of displaying the key indicators which are essential both for the contracting authority as well as for the project supplier. The basic parameter set describing a project includes the *tasks* (measured in person·month) to be executed within certain *agreed duration* (month) and those ones which are *really done* (person·month), as well as the *money* earned by the *supplier* (person·month), the *money* (person·month) spent by the contracting authority or the *client* and the *cumulative benefit* (person·month<sup>2</sup>) of the project over the time (Figure 9).

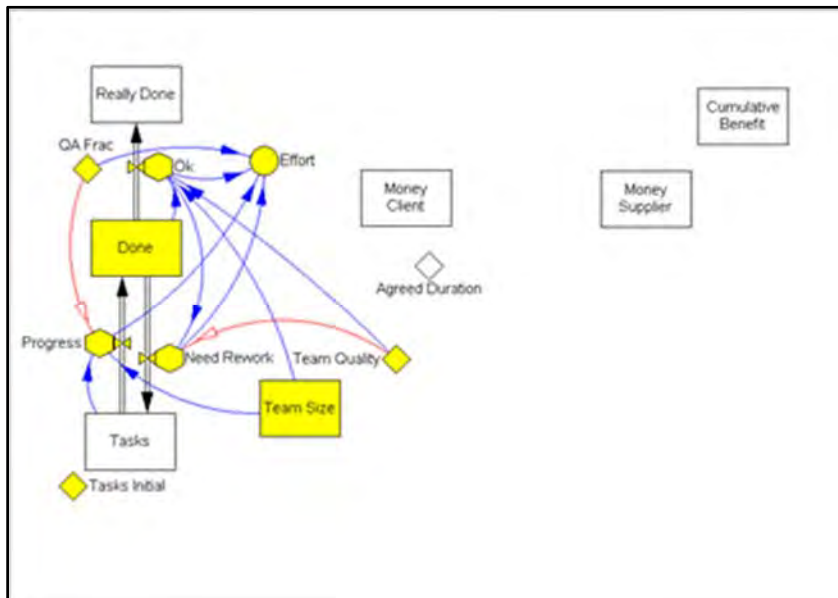
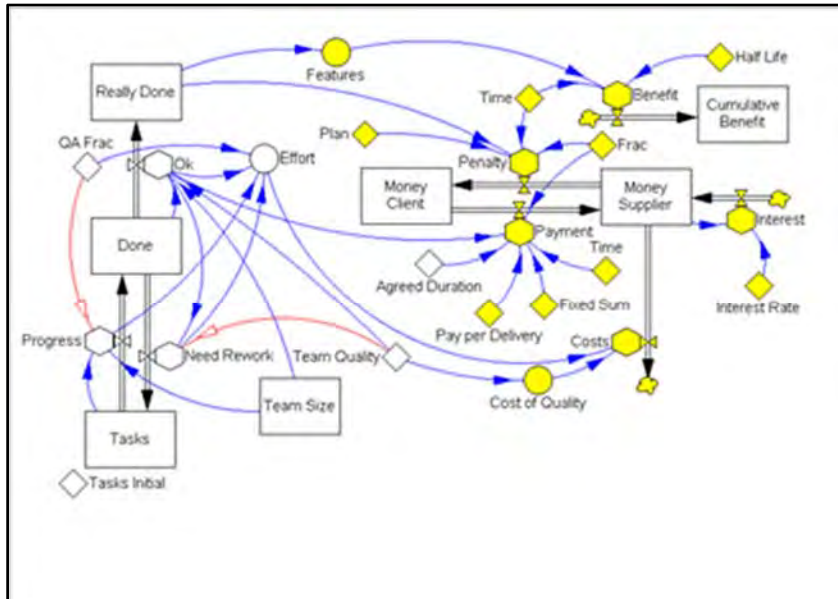

**Figure 10. Project Execution**

During project *progress*, planned *tasks* are completed. Therefore, planned *tasks* will change into the status *done*. However, not every executed task produces the intended

results but type I or type II errors (Atkinson, 1999). In these cases, work is done wrong respectively not as well as it could have been. Hence, these tasks *need rework* and change again into the status planned *tasks*. The fraction of tasks needing rework depends on *Team Quality*. On the other hand, tasks that are completed successfully pass into *really done*.

The model reflects this project executing structure (Figure 10). Similar models can be found for example in (Lyneis, 2007; Garcia, 2009; Sterman, 2000).



**Figure 11. Benefits of the Project Client and the Financial Aspects**

The next modeling step is to reflect the financial flows (*Payment*, *Penalty*, *Interest* and *Costs*) and other dependencies (Figure 11). The contract's term of payment is set by *Frac* which is the fraction of payment on a pay-per-delivery basis. A number bigger than 1 means a penalty applies for each delayed person month according the *Plan*. From the point of view of a public project client the more tasks are finished, the more *Features* can be put into use. Notice that for certain IT and other high-tech projects the *Half Life* during which the time specific benefit is reduced to the half the original planned value can be as short as 24 months.

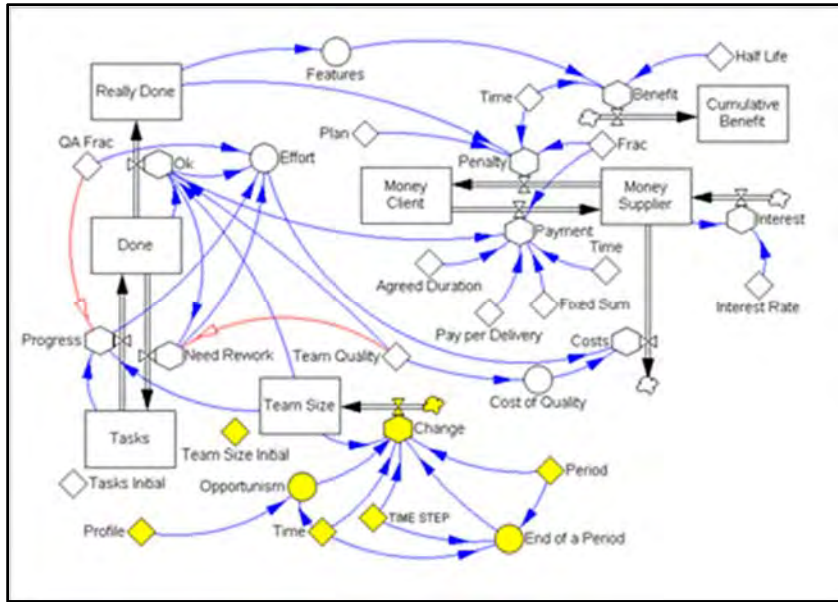

**Figure 12. Possible Opportunistic Behavior Regarding the Team Size**

Finally, two variants of the model are realized. Using the first one, shown in Figure 12, each participant acts as a possibly opportunistic project supplier. Depending on the value of *Frac* it may be beneficial to reduce *Team Size* at the cost of a significant project delay. *Frac* and *Team Size* are the two parameters which are to be controlled through the user interface shown in Figure 6.

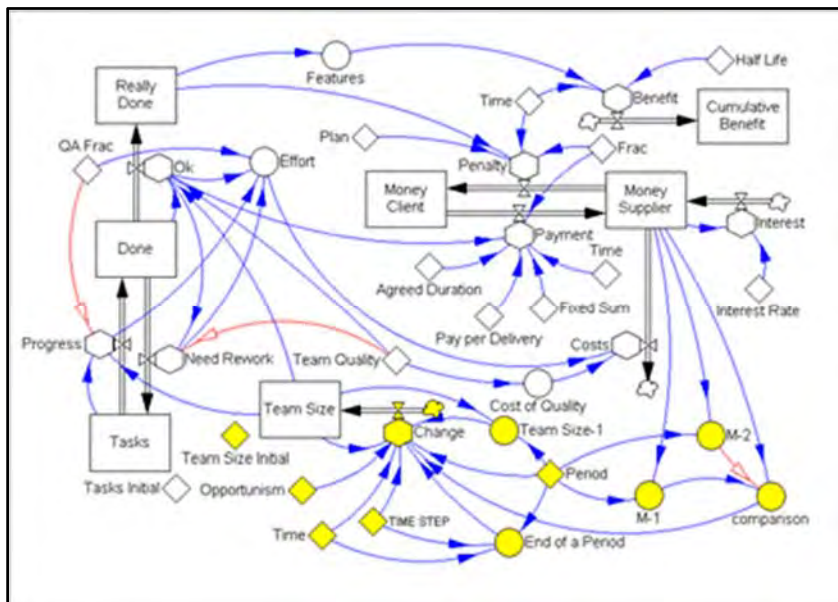

**Figure 13. Opportunistic Computer Player**

Figure 13 shows another model variant in which the opportunistic behavior is literally programmed. A participant of the interactive decision support based on such a model acts as a public project client designing a contract, or in other words, defining the value of *Frac*.



## Conclusions

Delays in public–private partnership projects cause significant disadvantages for public contracting authorities. In our research we want to analyze how project contracts that include carefully designed timely penalties may help to keep a project on track and within the planned timeline.

We have developed a prototype of a web based management cockpit for interactive project contracting. Core element of our prototype is a system dynamics model which can be easily replaced by a new version or even another system dynamics model to reflect the newest research results.

The described web based management cockpit allows students to play the role of both parties involved in PPP project acquisition and contracting: public contracting authority and private sector contractor. During a simulated project, the management cockpit informs the participants interactively about project contract and execution details. Observing students' actions allows understanding different effects of specific decisions and thereby helps to gain important insights into critical interdependencies of PPP project key indicators. On the one hand, these key indicators are the money invested by the public authority, the project's cumulative benefit, and the project duration. All three can be regarded as the key performance indicators for the public partner. He aims to maximize the cumulative project by simultaneously minimizing the money to be invested and project duration. On the other hand, there are the key performance indicators for the private partner: money spent and project duration. Foremost, the private sector contractor aims to maximize profit. He can do this by controlling project duration and resources assigned to the project, that is, manpower.

As expected, some of the students have learnt quickly to reduce team size to maximize the profit at the expense of a longer project duration. Our preliminary results indicate also the potential of a contract term of delay penalty to reduce the negative impact of such an opportunistic behavior.

This management cockpit is planned to be extended in future research. There already exists the concept that new models with a variety of adapted indicator sets will be used for additional interactive decision support.

## Summary

From our point of view, this specific web based management cockpit in combination with the underlying system dynamics model offers a high grade of flexibility and attractiveness for use in the area of project contracting issues with an international focus. Generally speaking, system dynamics can be seen as a powerful decision support tool which can be used in a variety of ways when implemented in a web based management cockpit for decision-makers in project contracting.

## References

- Atkinson. 1999. Roger Atkinson: Project management: cost, time, and quality, two best guesses and a phenomenon, its time to accept other success criteria. *International Journal of Project Management*, Volume 17 No. 6: 337–342, 1999.
- Baccarini. 1996. David Baccarini: The concept of project complexity–A review. *International Journal of Project Management*, Vol. 14, No. 4: 201–204, 1996.
- Bernheim. 1998. B. Douglas Bernheim and Michael D. Whinston: Incomplete Contracts and Strategic Ambiguity. *The American Business Review Vol.88.*, 902–932, 1998.



- Campbell. 2011. Greg Campbell: Delivering Local Government Projects—Effective Partnerships with the Private Sector. *Presentation to 2011 LGMA National Congress and Business Expo*, Cairns, AUS, 22–25 May 2011. Retrieved from <http://www.lgma.org.au/downloads/File/Delivering%20Local%20Government%20Projects%20Greg%20Campbell%20PAPER.pdf>
- Cooper. 1993. Cooper, K. and T. Mullen: Swords and plowshares: The rework cycles of defense and commercial software development projects. *American Programmer* 6 (5), 41–51, 1993.
- Daly. 2004. Maurice Daly: Lessons from the Liverpool City Council Experience: Recommendations for Public–Private Partnerships in Local Government. *Liverpool City Council Public Inquiry, Volume 2*, ISBN 1 920766 11 1, NSW Government, Liverpool, NSW, AUS, June 2004. Retrieved from [http://www.dlg.nsw.gov.au/dlg/liverpool/documents/Information/Liverpool\\_Inquiry\\_Volume\\_2.pdf](http://www.dlg.nsw.gov.au/dlg/liverpool/documents/Information/Liverpool_Inquiry_Volume_2.pdf)
- European Commission. 2003. Guidelines for Successful Public–Private Partnerships. European Commission, Brussels, Belgium, March 2003. Retrieved from [http://ec.europa.eu/regional\\_policy/sources/docgener/guides/ppp\\_en.pdf](http://ec.europa.eu/regional_policy/sources/docgener/guides/ppp_en.pdf)
- Flyvbjerg. 2002. Bent Flyvbjerg, Mette Skamris Holm, and Soren Buhl: Cost in Public Works Projects—Error or Lie? *Journal of the American Planning Association*, Volume 68 No. 3: 279–295, Summer 2002.
- Flyvbjerg. 2009. Bent Flyvbjerg, Massimo Garbuio, and Dan Lovallo: Delusion and Deception in Large Infrastructure Projects—Two Models for Explaining and Preventing Executive Disaster. *California Management Review*, Volume 51 No. 2: 170–193, Winter 2009.
- Garcia. 2009. Garcia J. Martin: Theory and Practical Exercises of System Dynamics. first edition 2006, full reviewed July 2009, July 2009.
- Gary. 2005. Michael Shayne Gary, Robert E. Wood: Mental Models, Decision Making and Performance in Complex Tasks. *The 2005 International Conference of the System Dynamics Society*, Proceedings, Boston, July 17–21, 2005.
- George. 2009. Rebecca George and Richard Porter: A clear sense of focus accountability and risk ownership. *National Audit Office (Hrsg.): Opinion pieces on improving commercial skills for complex government projects, Opinion pieces*, 33–36, National Audit Office, London, UK, 6 November 2009.
- Glückler. 2003. Johannes Glückler, Thomas Armbrüster: Bridging Uncertainty in Management Consulting: The Mechanisms of Trust and Networked Reputation. *Organization Studies*, 269–297, 2003.
- Greve. 2002. Carsten Greve and Niels Ejersbo: When Public–Private Partnerships Fail. *Nordisk Kommunalforskningskonference*, 2002. Retrieved from <http://busieco.samnet.sdu.dk/politics/nkk/papers/Papers/Carstengreve.pdf>
- Hood. 1995. Christopher Hood: The “New Public Management” in the 1980s: Variations on a Theme. *Accounting, Organizations and Society*, Vol. 20 No. 2/3: 93–109, Elsevier Science Ltd, London, UK, 1995.
- Hu. 2011. Bo Hu, Armin Leopold: Web-based Participatory System Dynamics Modelling – Concept and Prototype Development. *The 2011 International Conference of the System Dynamics Society, Proceedings*, Washington DC, July 24 – 28, 2011.
- Iossa. 2007. Elisabetta Iossa, Giancarlo Spagnolo, Mercedes Vellez: Contract Design in Public–Private Partnerships. *World Bank*, 1–101, 2007.

- Khanom. 2009. Niluf Akhter Khanom: Conceptual Issues in Defining Public Private Partnerships (PPPs). *Paper presented at the Asian Business Research Conference 2009, World Academy of Social Science, Dhaka, Bangladesh, April 11–12, 2009.*
- Leopold-Wildburger. 2013. Ulrike Leopold-Wildburger, Jürgen Strohhecker, Bo Hu, Markus Papst: The impact of management control cockpits on strategy implementation decision making performance. *Jahrestagung des Sozialwissenschaftlichen Ausschusses im Verein für Sozialpolitik, Jena, 25–27. April 2013.*
- Luo. 2007. Yadong Luo: An Integrated Anti-Opportunism System in International Exchange. *Journal of International Business Studies, 855–877, 2007.*
- Lyneis. 2001. Lyneis, J. M., Cooper, K. G. and Els, S. A.: Strategic management of complex projects: a case study using system dynamics. *System Dynamics Review, 17: 237–260, 2001.*
- Lyneis. 2007. James M. Lyneis and David N. Ford: System dynamics applied to project management: a survey, assessment, and directions for future research. *Syst. Dyn. Rev., 23: 157–189, 2007.*
- Mayer. 2004. Kyle J. Mayer and Nicholas S. Argyres: Learning to Contract: Evidence from the Personal Computer Industry. *Organization Science, 394–410, 2004.*
- Mizzel. 2007. Carolyn Mizzel and Linda Malone: A Project Management Approach to Using Simulation for Cost Estimation on Large, Complex Software Development Projects. *IEEE Engineering Management Review, Vol. 37, No. 2, IEEE, Second Quarter 2009.*
- NASA. 2010. National Aeronautics and Space Administration (NASA): NASA Work Breakdown Structure (WBS) Handbook. *NASA/SP-2010-3404, NASA, Washington, DC, January 2010.*
- National Audit Office. 2009. National Audit Office: Commercial skills for complex government projects. National Audit Office (Hrsg.): *Report by the Comptroller and Auditor General, Report by the Comptroller and Auditor General, HC 962, Session 2008–2009, ISBN 978-0-10-296328-1, National Audit Office, London, UK, 6 November 2009.*
- National Audit Office. 2011. National Audit Office: Lessons from PFI and other projects. National Audit Office (Hrsg.): *Report by the Comptroller and Auditor General, Report by the Comptroller and Auditor General, HC 920, Session 2010–2012, National Audit Office, London, UK, 28 April 2011.*
- National Council. 2002. The National Council for Public–Private Partnerships: For the Good of the People: Using Public–Private Partnerships to meet America’s essential needs. 2002.
- National Council. 2009. The National Council for Public–Private Partnership: Press Kit for The National Council for Public–Private Partnerships. 2009 Retrieved from <http://www.ncppp.org/presskit/presskit.pdf>
- Niemeier. 2013. Hans-Martin Niemeier: Expanding Airport Capacity Under Constraints in Large Urban Areas: The German Experience. *Organisation for Economic Co-operation and Development (OECD): International Transportant Forum, International Transportant Forum, Discussion Paper No. 2013–4, Organisation for Economic Co-operation and Development (OECD), Paris, France, March 2013.*
- PMI. 2004. Project Management Institute (PMI): A guide to the project management body of knowledge: PMBOK guide. 3rd edition, ISBN 1-930699-45-X, Project Management Institute (PMI), Newtown Square, PA. 2004.



- Provost. 2011. Lyn Provost: Managing the implications of public private partnerships. *Discussion paper*, 10 November 2011. Retrieved from <http://oag.govt.nz/2011/public-private-partnerships/docs/public-private-partnerships.pdf>
- Roth. 2010. Roth, Armin: Unternehmenssteuerung mit Management-Cockpits. *Wirtschaftsinformatik & Management*, S. 20–25, 2010.
- Sterman. 1992. John D. Sterman: System Dynamics Modeling for Project Management. 1992. Retrieved from <http://web.mit.edu/jsterman/www/SDG/project.pdf>
- Sterman. 2000. John D. Sterman: Business Dynamics—Systems Thinking and Modeling for a Complex World. ISBN 007238915X, McGraw-Hill Higher Education, 2000.
- Sun. 2008. Lan Sun and Subhrendu Rath: Fundamental Determinants, Opportunistic Behavior and Signaling Mechanism: An Integration of Earnings Management Perspectives. *International Review of Business Research Papers*, 406–420, 2008.
- Winch. 2012. Graham M. Winch, Masamitsu Onishi and Sandra Schmidt (Eds): Taking Stock of PPP and PFI Around the World. *Graham M. Winch, Masamitsu Onishi and Sandra Schmidt (Hrsg.): ACCA international research programme, Summary of Research Report 126*, ISBN 978-1-85908-475-5, The Association of Chartered Certified Accountants (ACCA), London, UK, February 2012.
- Wood. 2012. Roy Wood: Schedule-Driven Costs in Major Defense Programs. *Ninth Annual Acquisition Research Symposium, Proceedings, Vol. II: 16–27*, Naval Postgraduate School, Monterey CA, 30 April 2012.
- Zarco-Jasso. 2005. Hugo Zarco-Jasso: Public–private partnerships: a multidimensional model for contracting. *International Journal of Public Policy*, Vol. 1, No. 1/2: 22–40, 2005.

## Acknowledgements

This research was sponsored by the Naval Postgraduate School (NPS), Broad Agency Announcement (BAA) NPS-BAA-12-002 for the Acquisition Research Program.





ACQUISITION RESEARCH PROGRAM  
GRADUATE SCHOOL OF BUSINESS & PUBLIC POLICY  
NAVAL POSTGRADUATE SCHOOL  
555 DYER ROAD, INGERSOLL HALL  
MONTEREY, CA 93943

[www.acquisitionresearch.net](http://www.acquisitionresearch.net)



Acquisition Research:  
Creating Synergy for Informed Change

MAY 14 – 15, 2014 · EMBASSY SUITES MONTEREY BAY - SEASIDE  
MONTEREY, CA

**Matthias Dehmer, Bo Hu and Stefan Pickl**

Project Contracting and Strategic Planning (Scheduling)

**System Dynamics Modeling and Management  
Science Approaches Toward Increasing  
Acquisition Process Efficiency**



## Acquisition Research: Creating Synergy for Informed Change

MAY 14 – 15, 2014 · EMBASSY SUITES MONTEREY BAY - SEASIDE  
MONTEREY, CA



### **System dynamics modeling for project acquisition**



A web based management  
cockpit for project contracting



Conclusion and further  
research activities

# Introduction / Motivation

- Public private partnership (PPP)
- Contracting: impact on acquisition process efficiency
- Conflict of interests: Public-Private: delay and additional costs in project execution => opportunistic behavior of private-sector suppliers
- New approach:
  - system dynamics model
  - web based tool
- Goal: train project purchasers to design optimal contracts

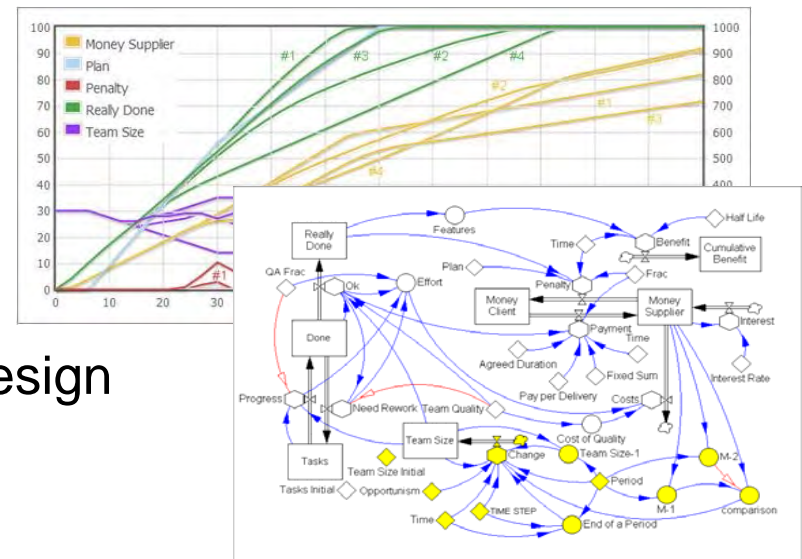

# Public meets private interests in PPP projects

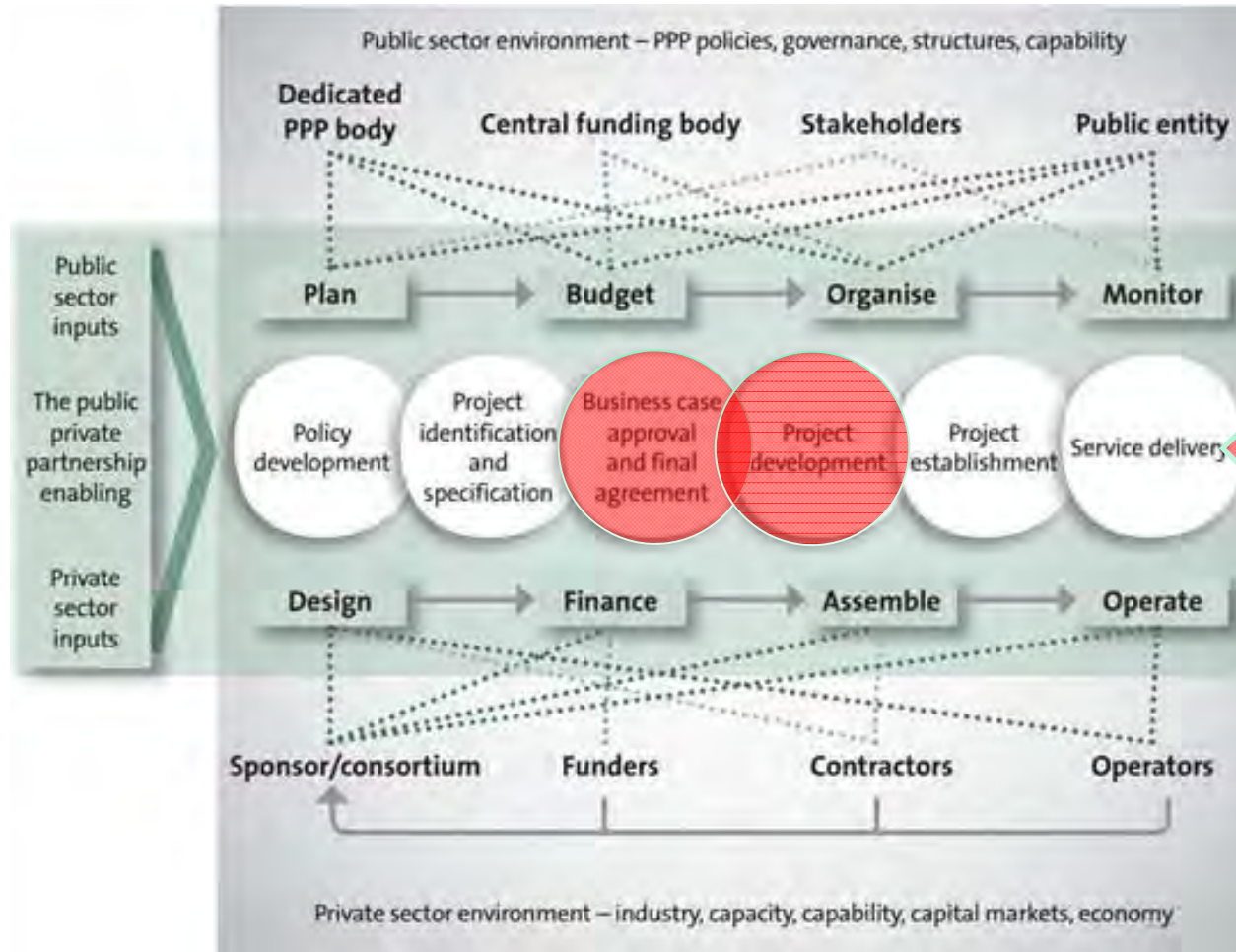

This is where public interest meets private interest and opportunistic behavior evolves.

# Understanding opportunistic behavior is a critical success factor for PPP projects

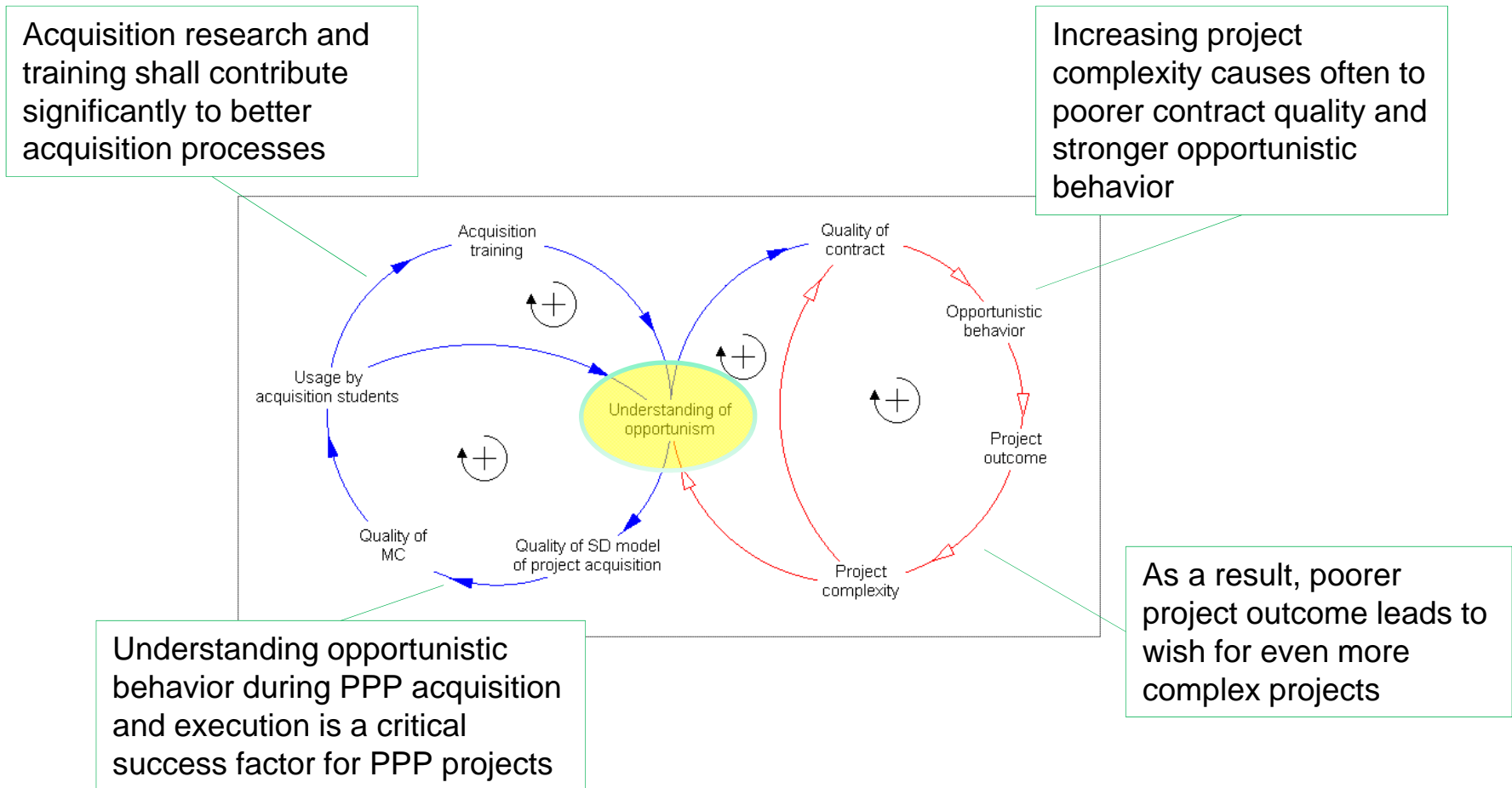

## Purpose of our web-based simulation tool for public-private project contracting, based on a system dynamics model

- To give a better understanding of the opportunistic behavior of the private-sector supplier.
- Gives the participants the possibility to test different outcomes of the consequences of different contract types.
- Shows how project contracts that include incentives and carefully designed timely penalties help to keep a project on track, in budget and within the planned timeline
- Our web tool shall be used for teaching project contracting in the future

# Key indicators describing a PPP-project

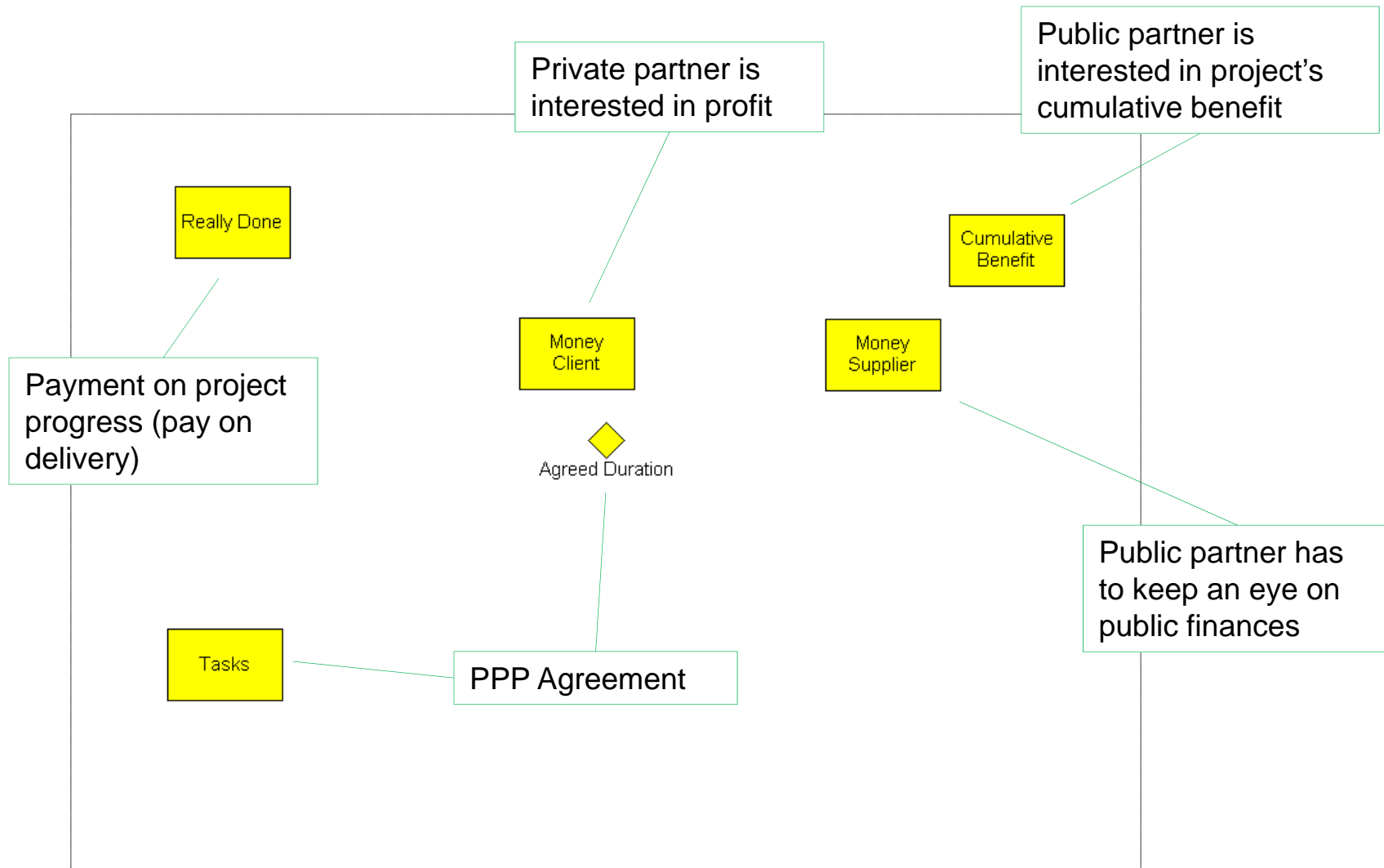

# Project executing structure

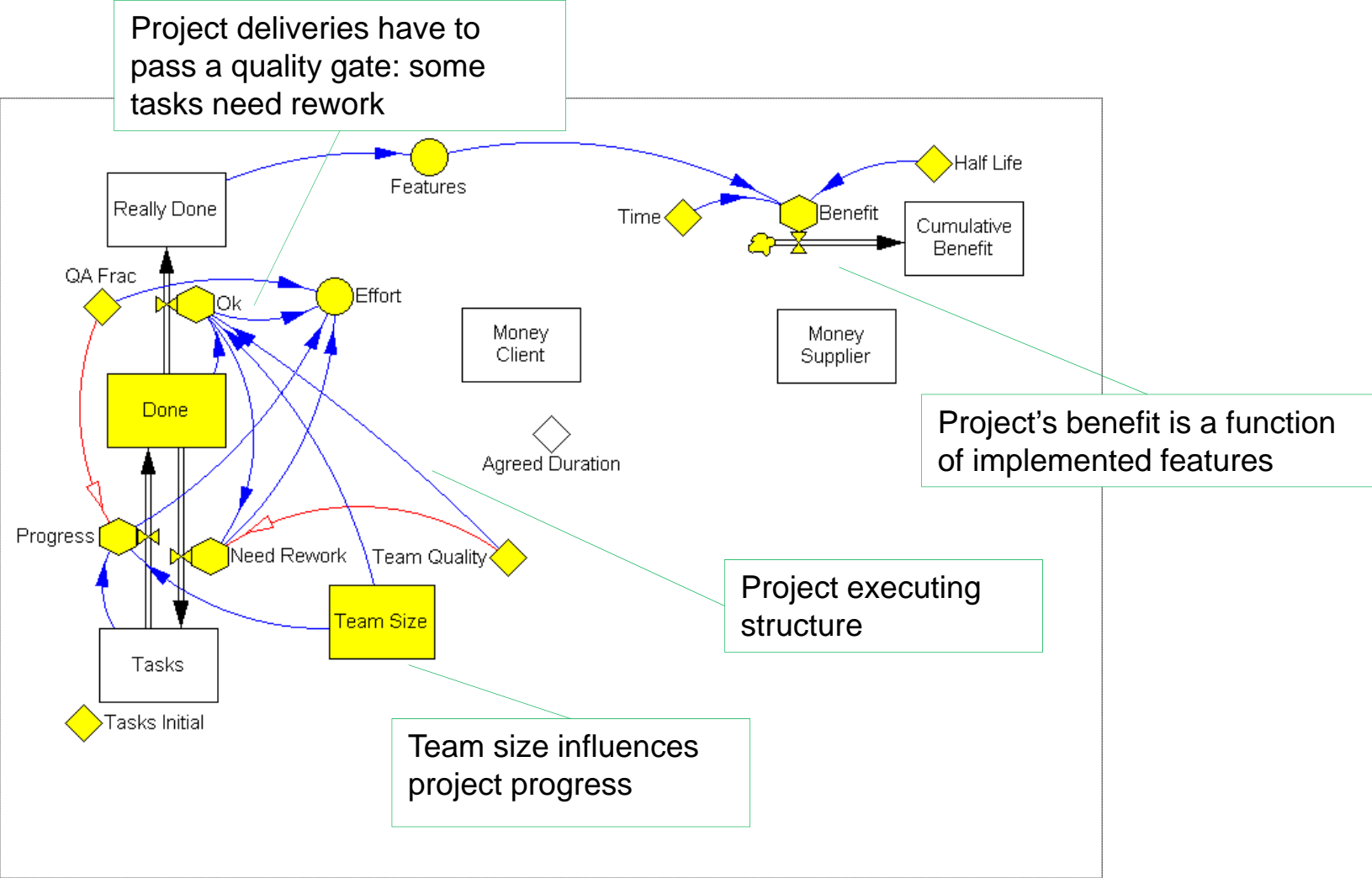

# Benefits for the public and financial aspects

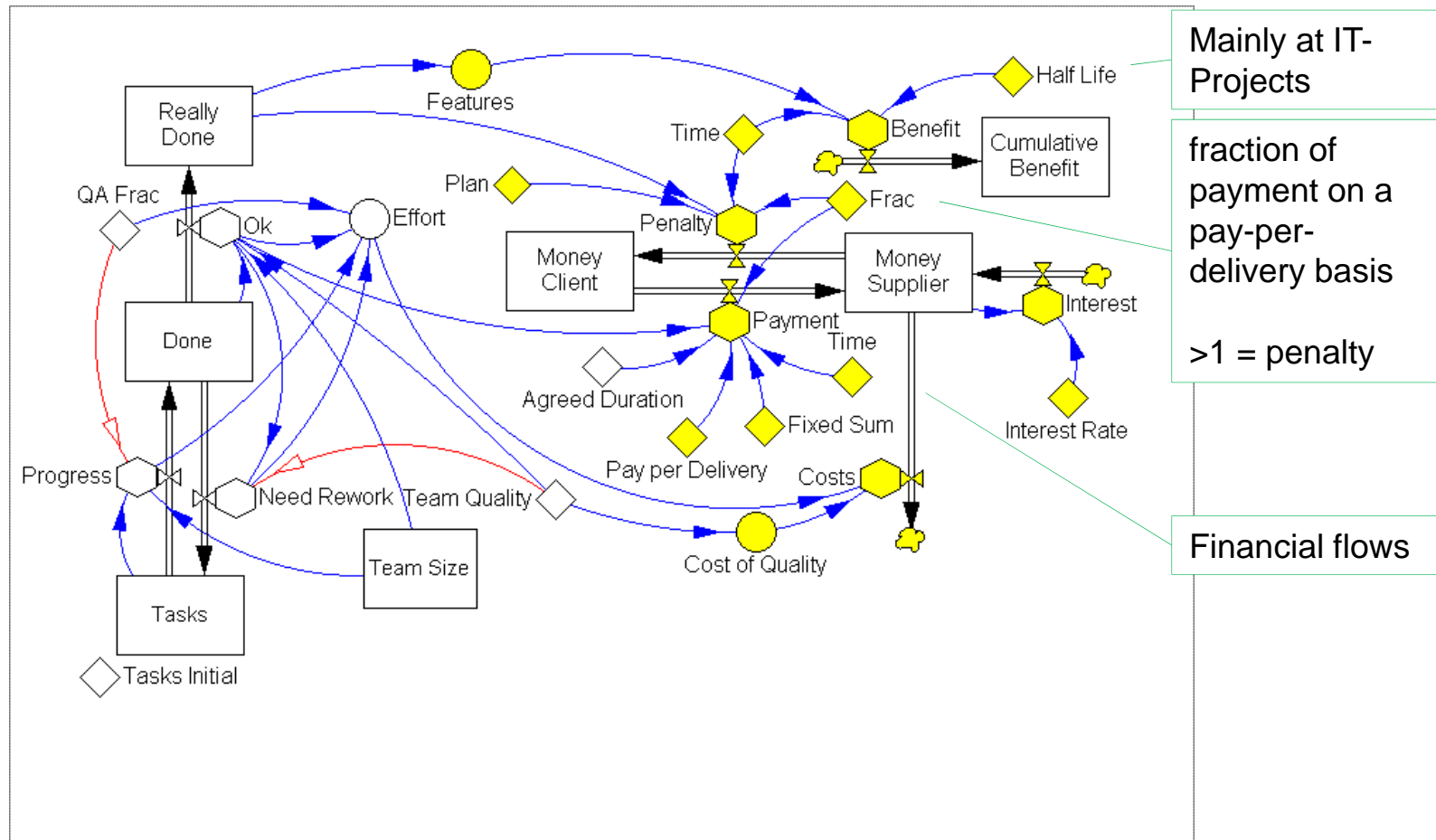

Mainly at IT-Projects

fraction of payment on a pay-per-delivery basis  
 $>1 = \text{penalty}$

Financial flows

# Setup for the field study: opportunistic project supplier

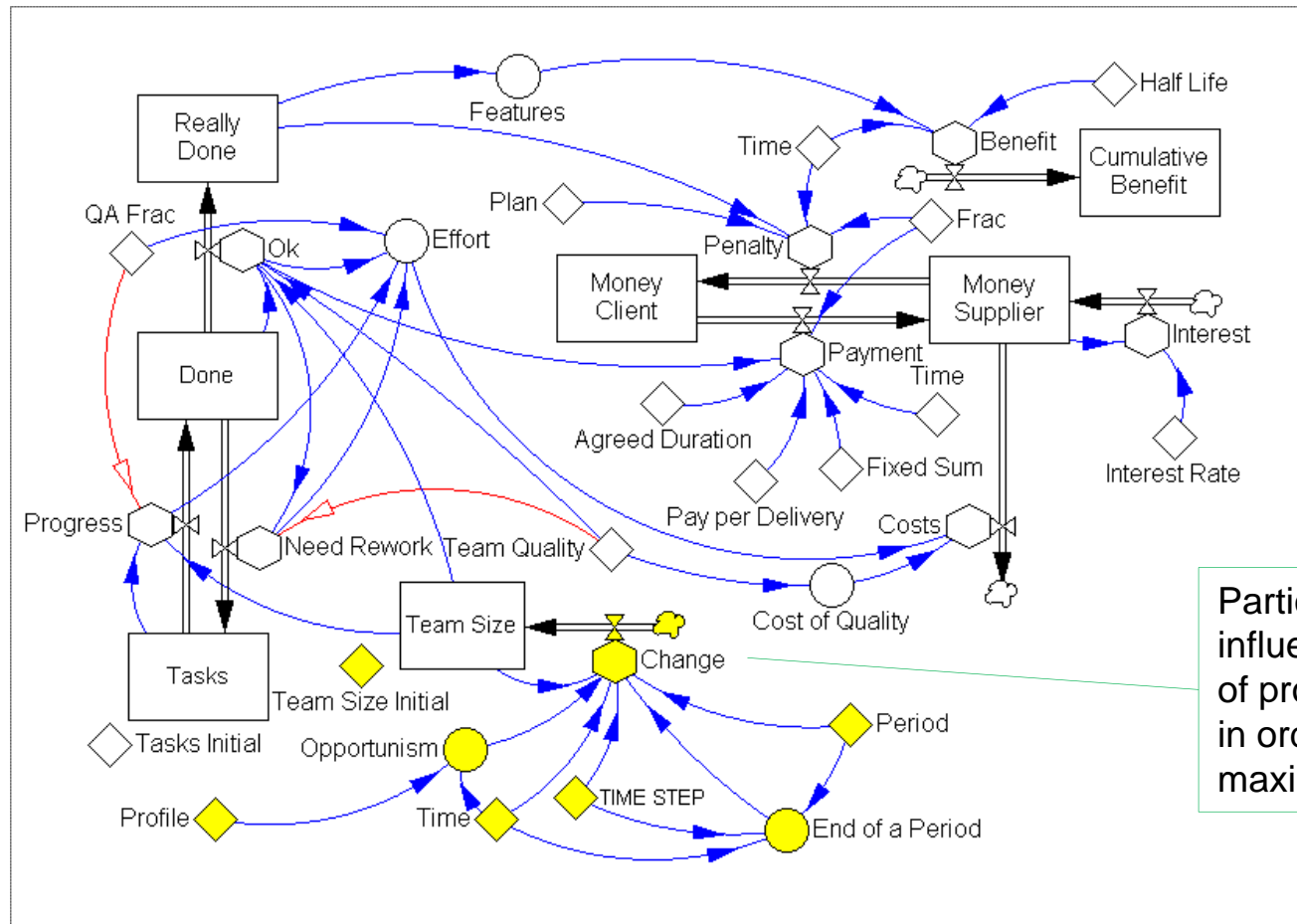



## Acquisition Research: Creating Synergy for Informed Change

MAY 14 – 15, 2014 · EMBASSY SUITES MONTEREY BAY - SEASIDE  
MONTEREY, CA



System dynamics modeling for  
project acquisition



**A web based management  
cockpit for project contracting**



Conclusion and further  
research activities

# Our web tool for project contracting

- Influence the pilot study decision process
  - accuracy of the participant's mental model
  - presentation of data material
- Possibility to achieve optimized decisions:
  - Better understandable data and information management
  - by the prototype of a web tool for project studies supported by a System Dynamics model



# Use case diagram for a web tool for collective studies

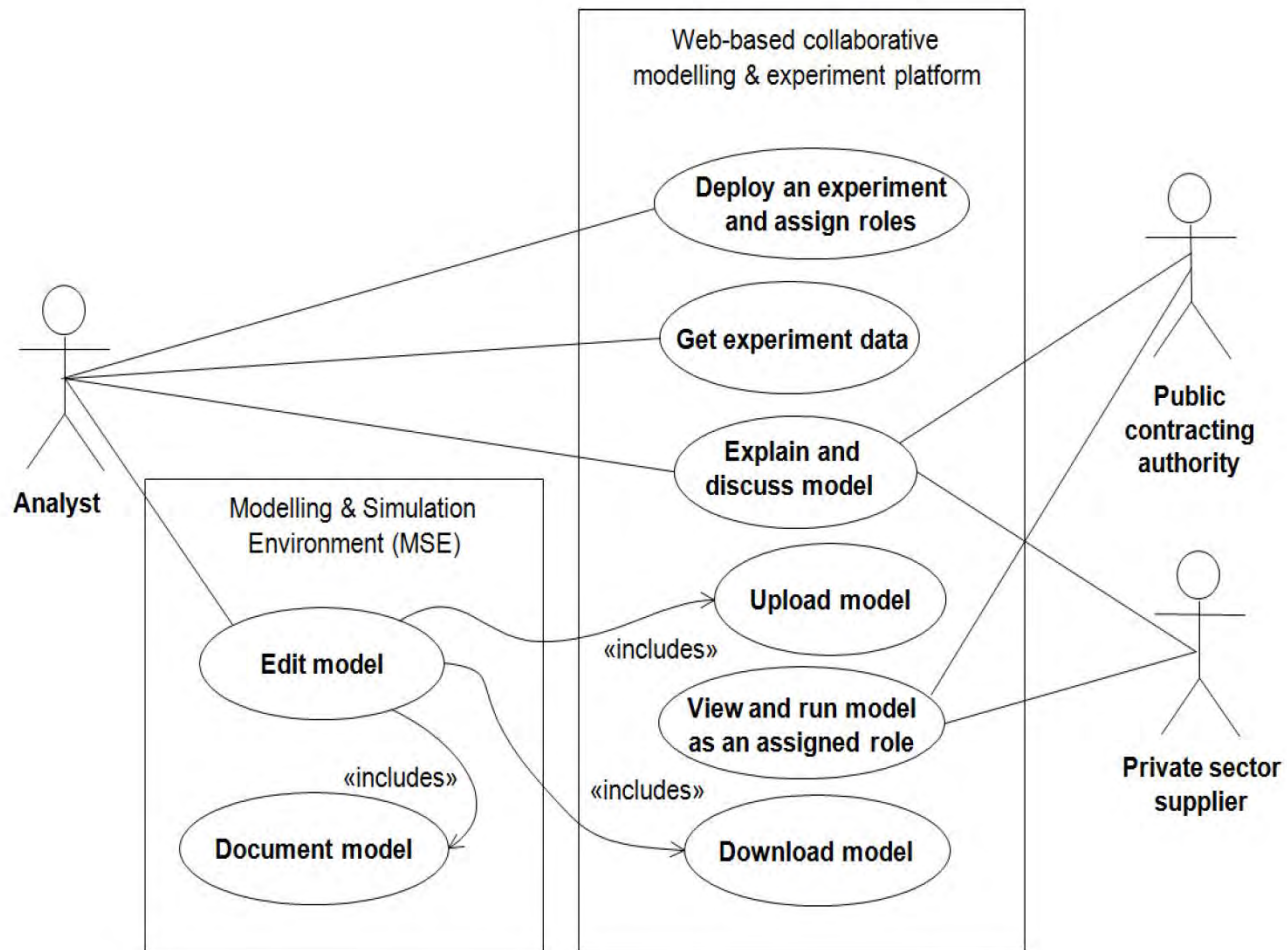

# System architecture of the collaborative modelling and experiment platform

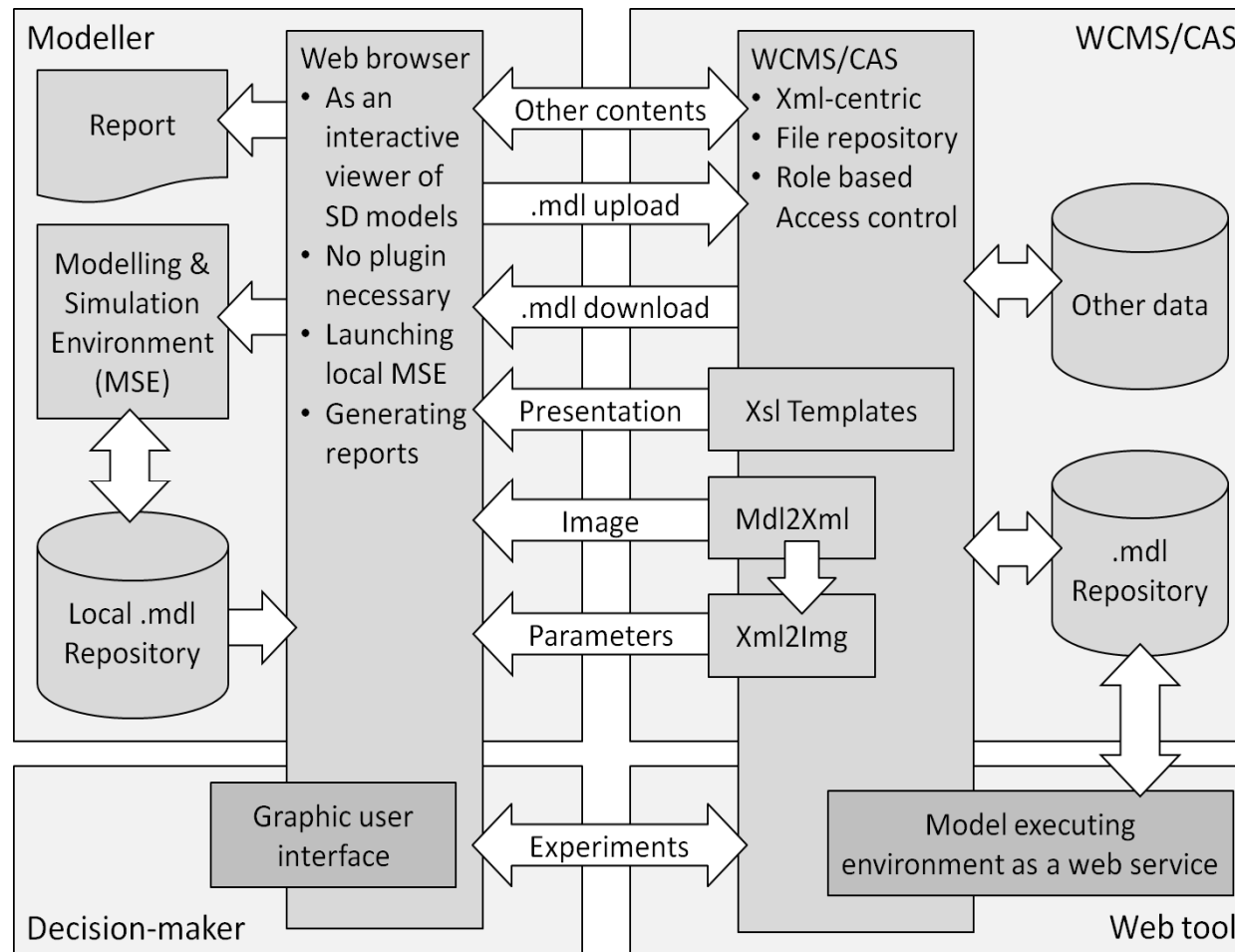

# User interface of the web based management cockpit for project contracting

Key performance indicators inform about decision results

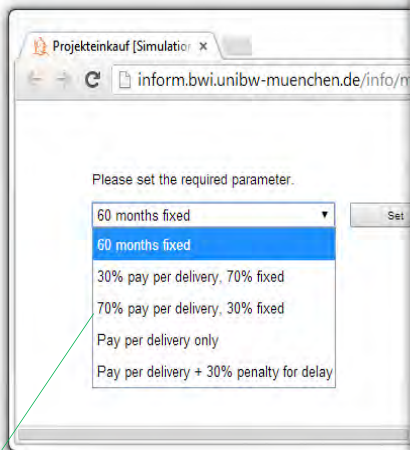

Individual studies can be configured by administrators

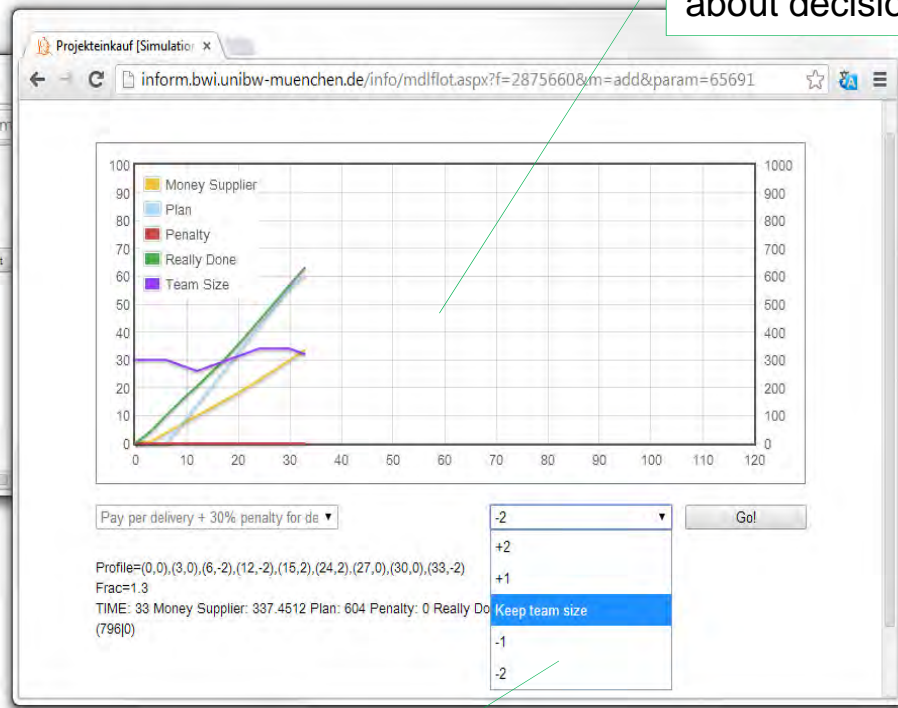

Participants influence size of project team during simulation run

# Features of the web tool for project contracting

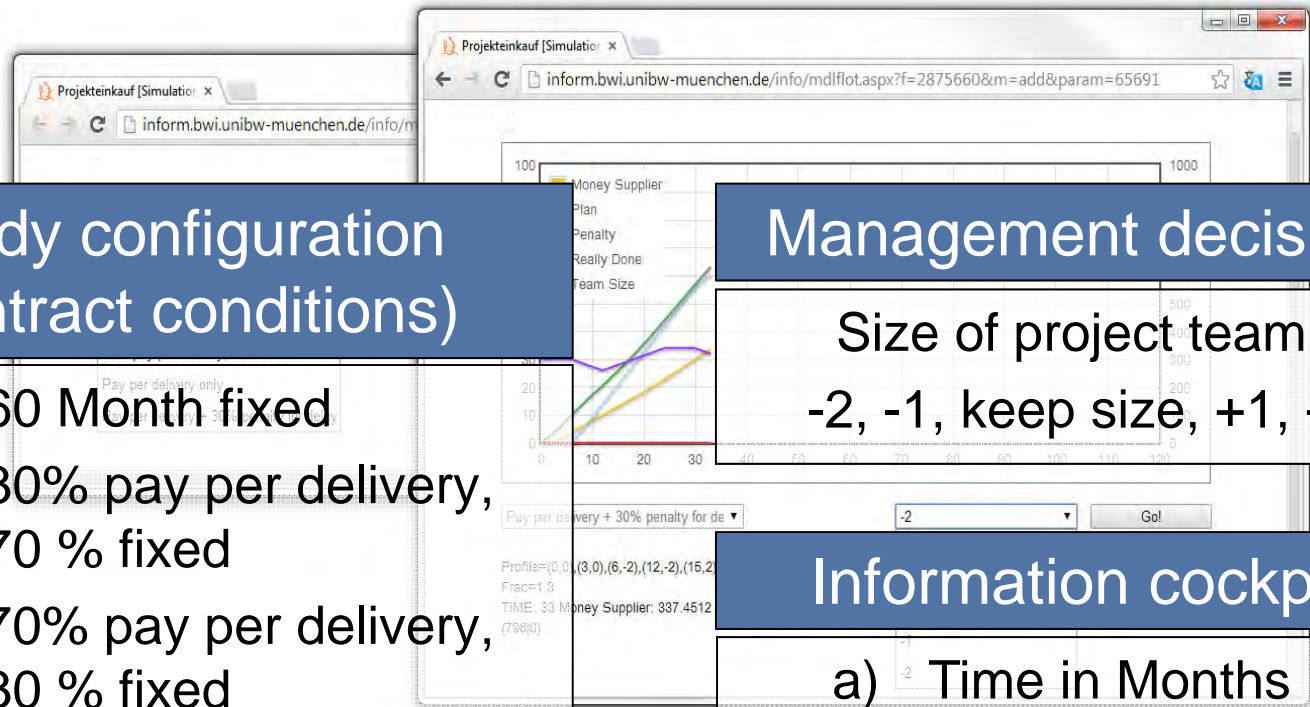

## Study configuration (contract conditions)

- a) 60 Month fixed
- b) 30% pay per delivery, 70 % fixed
- c) 70% pay per delivery, 30 % fixed
- d) Pay per delivery only
- e) Pay per delivery + 30% penalty for delay

**Role: Administrator**

## Management decision

Size of project team:  
-2, -1, keep size, +1, +2

## Information cockpit

- a) Time in Months
- b) Money earned
- c) Finished tasks
- d) Actual team size

**Role: Private partner**

# Configuration for the pilot study

- Different public-private partnership contract conditions
- 14 participants = single project managers (private partner)
- 4 consistent rounds
- Time limit for project completion: 120 Months
- Initial size of project team: 30 members

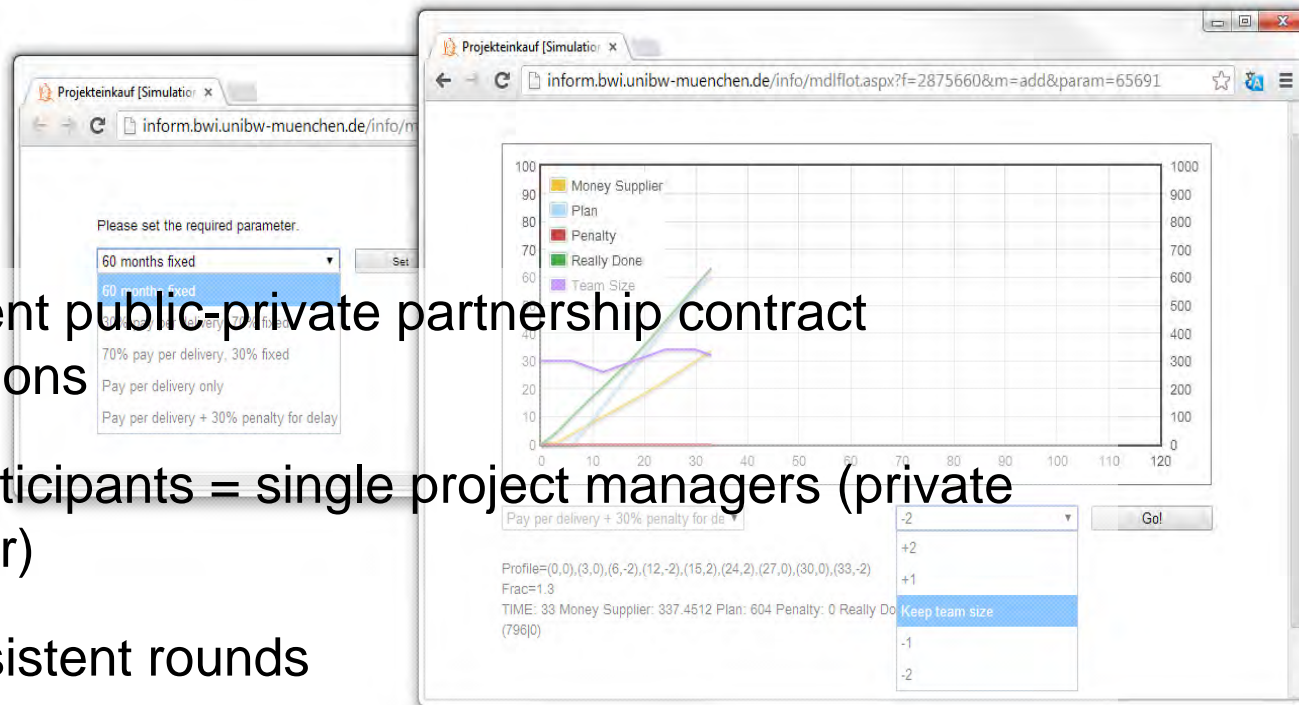

# A flight simulator for project execution for studying opportunistic behavior

- Understanding conflicting public and private interests in a PPP project
- Understanding possible opportunistic behavior of private-sector project suppliers

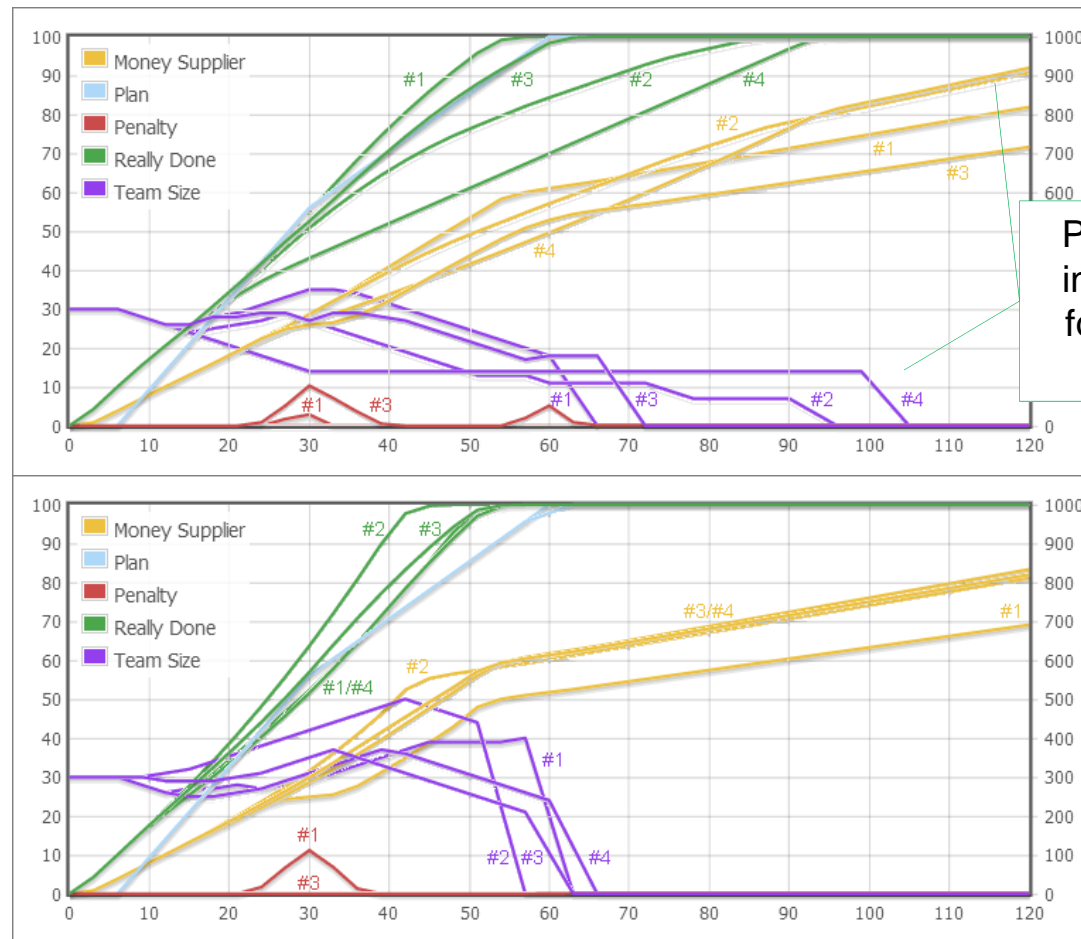



## Acquisition Research: Creating Synergy for Informed Change

MAY 14 – 15, 2014 · EMBASSY SUITES MONTEREY BAY - SEASIDE  
MONTEREY, CA



System dynamics modeling for  
project acquisition



A web based management  
cockpit for project contracting



**Conclusion and further  
research activities**

## Conclusion

- The web tool allows students to play decision makers and to understand and realize the effects of their specific actions.
- The web tool in combination with a System Dynamics model offers a high grade of flexibility and attractiveness for further studies.
- The System Dynamics model shows the critical interdependencies of the key performance indicators for PPP projects.
- Outlook:
  - Further studies with more students (public partner)
  - Improvement of the web tool
  - Configuration of further specific scenarios in the System Dynamics model

# NATO courses

- Developing new NATO training course on operational analysis in defense decisions
- Motivating senior leaders for operations research issues
- Carrying out existing comprehensive NATO courses on hard and soft OR

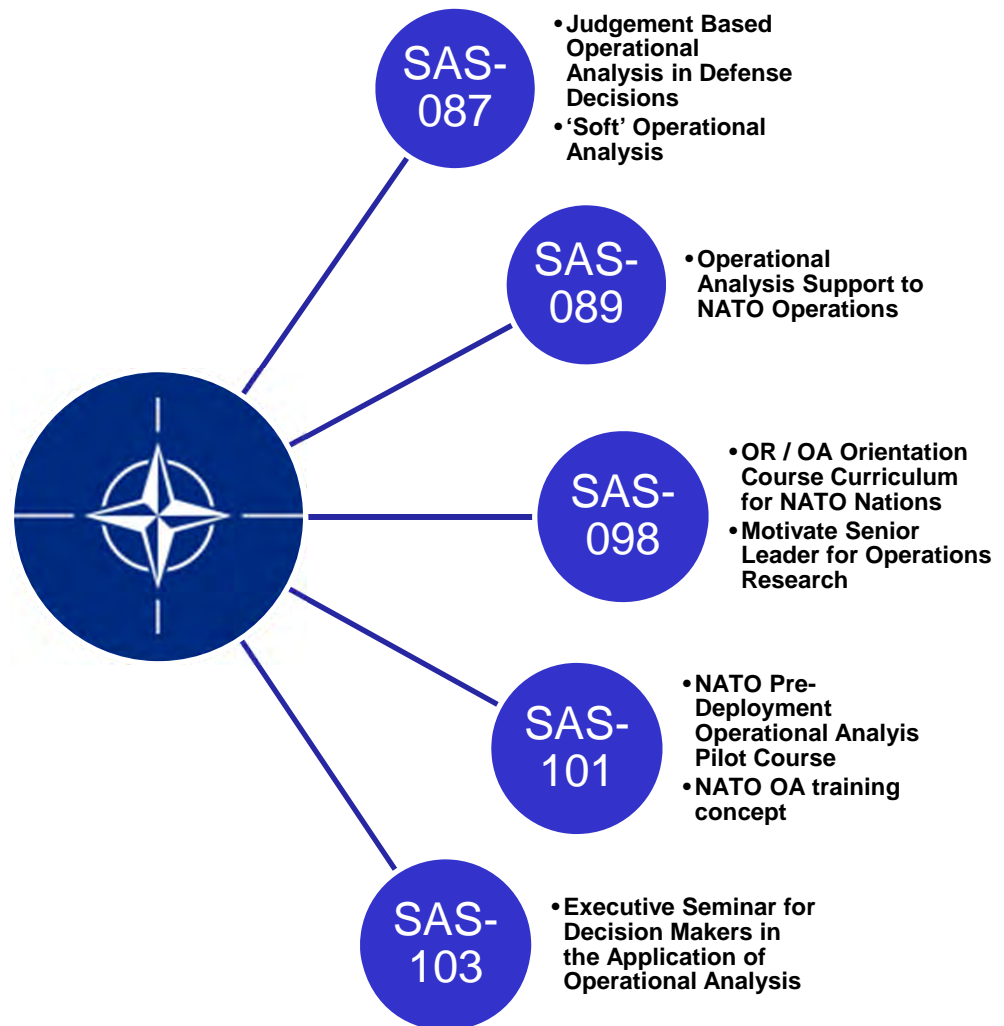

# RiKoV



- Joint project together with KIT, FHK and Airbus DS; Consortium leader: UniBw
- Sponsor: German Federal Ministry of Education and Research
- Critical infrastructure protection (CIP) in the fight against terrorism
- Scenario-based multi-criteria decision support balancing protective effects, costs and acceptance
- Management of uninsurable security risks
- Mathematical modeling and numeric simulations in combination with real world experiments

# Structural network analysis

- How can we quantify the structure of a network?
  - A topological descriptor (measure) is a mapping  $I : \mathcal{G} \rightarrow \mathbb{R}$
  - Prominent examples are the Wiener index and Randić index

$$W(G) := \frac{1}{2} \sum_{i=1}^N \sum_{j=1}^N d(v_i, v_j) \quad R(G) := \sum_{(v_i, v_j) \in E} [k_{v_i} k_{v_j}]^{-\frac{1}{2}}$$

- Using computational techniques a special graph entropy can be introduced:

$$I_f(G) = - \sum_{i=1}^{|V|} \frac{f(v_i)}{\sum_{j=1}^{|V|} f(v_j)} \log \left( \frac{f(v_i)}{\sum_{j=1}^{|V|} f(v_j)} \right)$$

where

$$f(v_i) := \alpha^{c_1 |S_1(v_i, G)| + c_2 |S_2(v_i, G)| + \dots + c_{\rho(G)} |S_{\rho(G)}(v_i, G)|}$$

$$c_k > 0, 1 \leq k \leq \rho(G), \alpha > 0$$

- Graph entropies turned out to be quite unique when discriminating graphs structurally

# Uniqueness of structural network measures

- Example: Let  $\mu\delta(G) := \frac{\sum_i \delta_i}{N}$  and let  $I_{deg}(G) := -\sum_{i=1}^k \frac{|\delta_i|}{N} \log \frac{|\delta_i|}{N}$

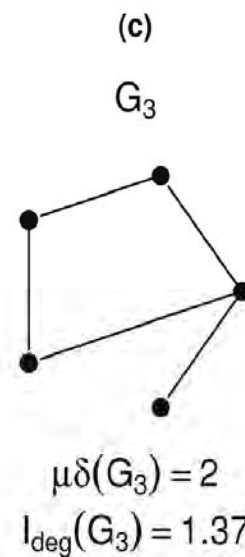
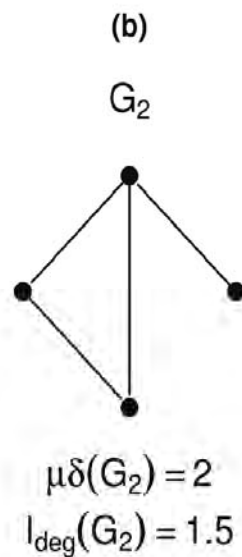
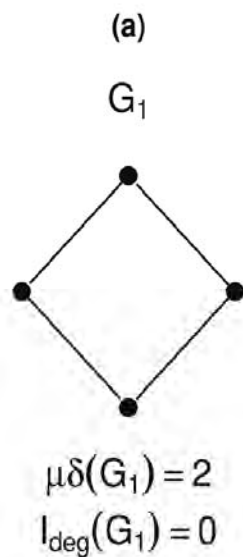

- Graph entropy measures play an important role in a variety of problem areas, including biology, chemistry, and sociology

# RAHS – Risk Assessment and Horizon Scanning

- Quantitative methods of future studies
- Web mining: periodic scanning of keywords in more than 100 languages of the World
- Big data: trend and geographic analysis
- Identifying hot spots of the near future

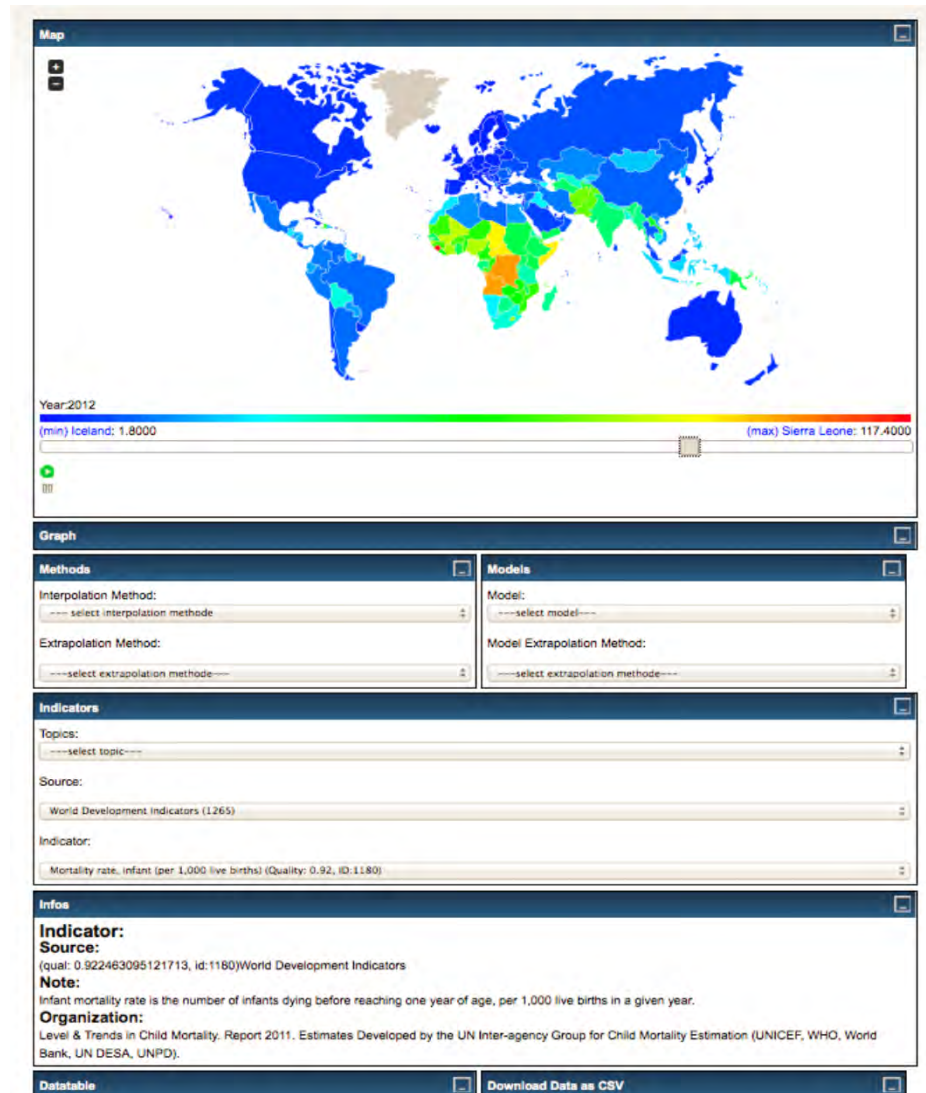

# System dynamics modeling and simulation using real data to compare different (bailout) policies (of Greece)

What has happened in Greece: Austerity reduces both debt and GDP

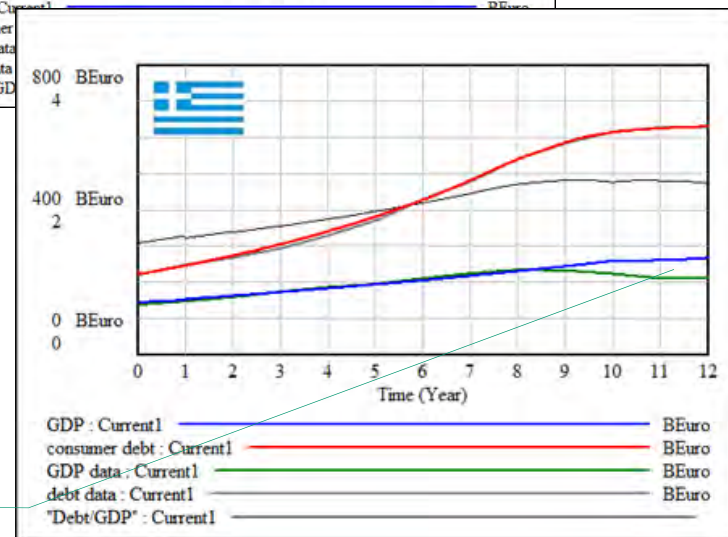
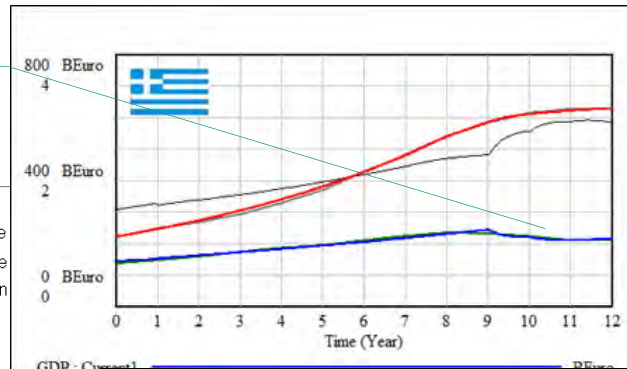
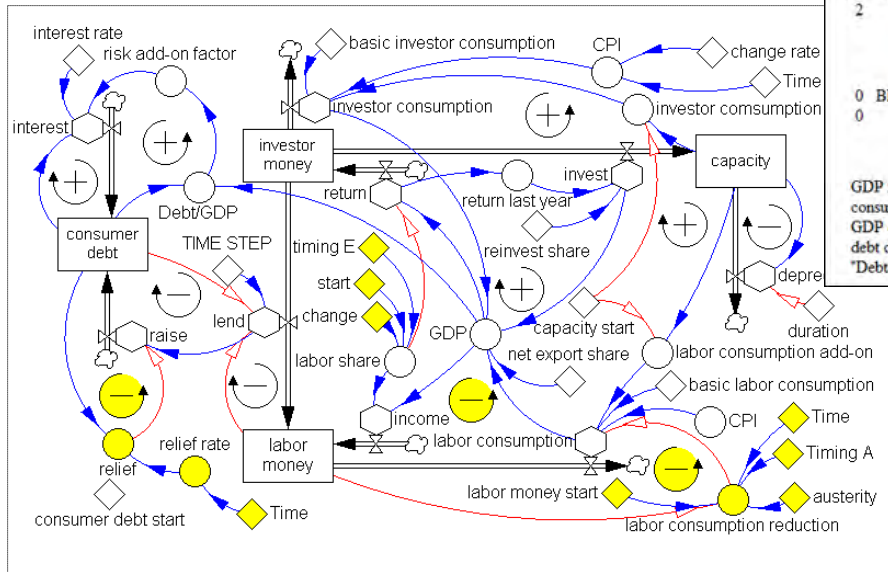

What would have happened: 20%+ Higher GDP through higher income equality

Data source: eurostat

# In a two-country case: policy makers facing a Prisoners' Dilemma

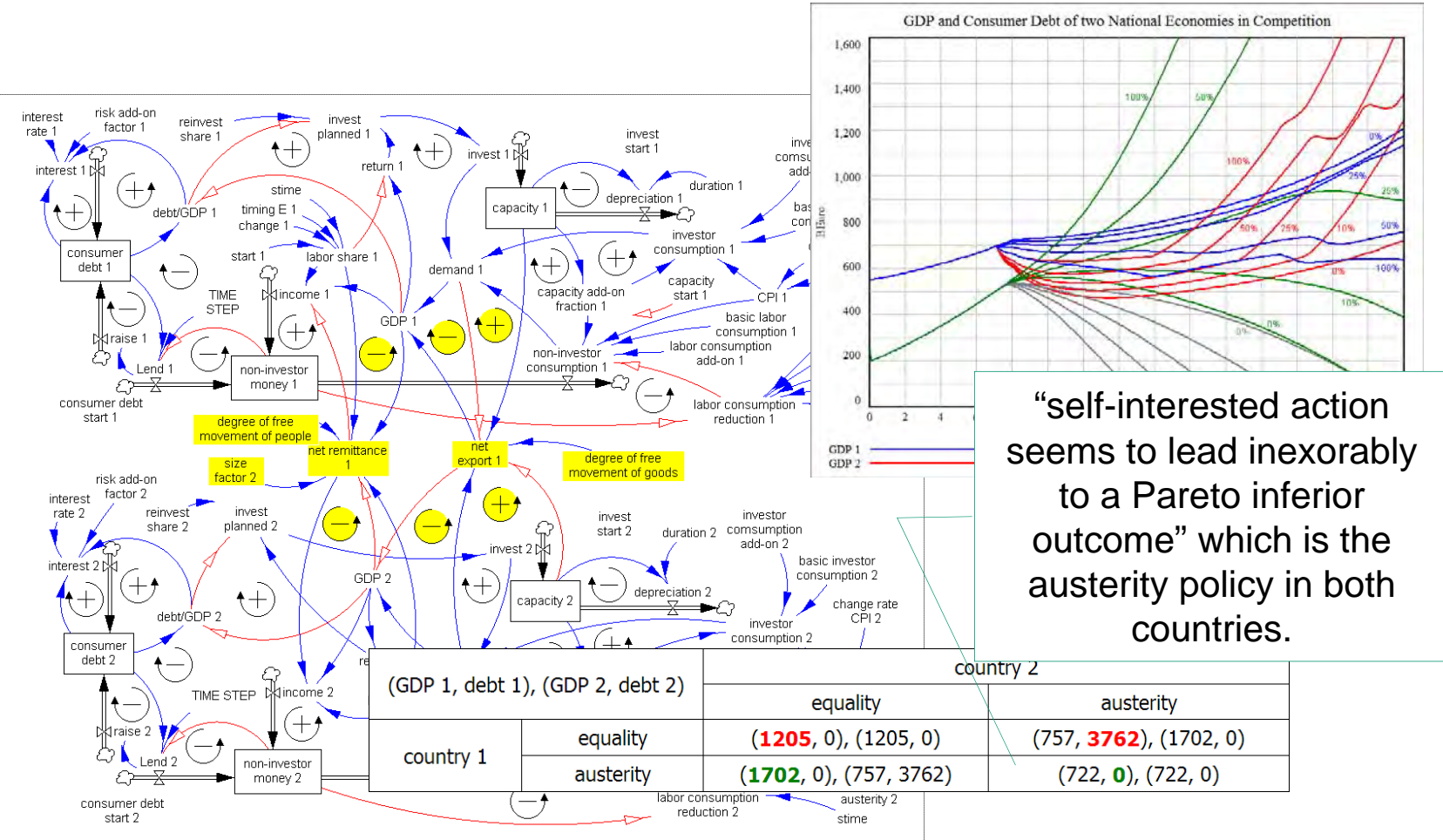

“self-interested action seems to lead inexorably to a Pareto inferior outcome” which is the austerity policy in both countries.

Lipman 1986





## Acquisition Research: Creating Synergy for Informed Change

MAY 14 – 15, 2014 · EMBASSY SUITES MONTEREY BAY - SEASIDE  
MONTEREY, CA

**Matthias Dehmer, Bo Hu and Stefan Pickl**

### **Q&A**

Project Contracting and Strategic Planning (Scheduling)

**System Dynamics Modeling and Management Science Approaches  
Toward Increasing Acquisition Process Efficiency**