



# Using Open Systems Architecture to Revolutionize Capability Acquisition

Acquisition Reform Symposium  
13 May 2015

Nickolas Guertin, PE

DASN RDT&E, Director for Transformation

[Nickolas.H.Guertin@navy.mil](mailto:Nickolas.H.Guertin@navy.mil)

Co-authored by Robert Sweeney &  
Douglas Schmidt, PhD

Opinions expressed are those of the authors & do not reflect official policy or position of the US Government

Distribution Statement A: Approved for public release

# Report Documentation Page

*Form Approved*  
*OMB No. 0704-0188*

Public reporting burden for the collection of information is estimated to average 1 hour per response, including the time for reviewing instructions, searching existing data sources, gathering and maintaining the data needed, and completing and reviewing the collection of information. Send comments regarding this burden estimate or any other aspect of this collection of information, including suggestions for reducing this burden, to Washington Headquarters Services, Directorate for Information Operations and Reports, 1215 Jefferson Davis Highway, Suite 1204, Arlington VA 22202-4302. Respondents should be aware that notwithstanding any other provision of law, no person shall be subject to a penalty for failing to comply with a collection of information if it does not display a currently valid OMB control number.

1. REPORT DATE <b>13 MAY 2015</b>		2. REPORT TYPE		3. DATES COVERED <b>00-00-2015 to 00-00-2015</b>	
4. TITLE AND SUBTITLE <b>Using Open Systems Architecture to Revolutionize Capability Acquisition</b>				5a. CONTRACT NUMBER	
				5b. GRANT NUMBER	
				5c. PROGRAM ELEMENT NUMBER	
6. AUTHOR(S)				5d. PROJECT NUMBER	
				5e. TASK NUMBER	
				5f. WORK UNIT NUMBER	
7. PERFORMING ORGANIZATION NAME(S) AND ADDRESS(ES) <b>Deputy Assistant Secretary of the Navy (DASN) for ,Research Development Test and Evaluation (RDT&amp;E),1000 Navy Pentagon 4C656,Washington,DC,20350</b>				8. PERFORMING ORGANIZATION REPORT NUMBER	
9. SPONSORING/MONITORING AGENCY NAME(S) AND ADDRESS(ES)				10. SPONSOR/MONITOR'S ACRONYM(S)	
				11. SPONSOR/MONITOR'S REPORT NUMBER(S)	
12. DISTRIBUTION/AVAILABILITY STATEMENT <b>Approved for public release; distribution unlimited</b>					
13. SUPPLEMENTARY NOTES					
14. ABSTRACT					
15. SUBJECT TERMS					
16. SECURITY CLASSIFICATION OF:			17. LIMITATION OF ABSTRACT <b>Same as Report (SAR)</b>	18. NUMBER OF PAGES <b>21</b>	19a. NAME OF RESPONSIBLE PERSON
a. REPORT <b>unclassified</b>	b. ABSTRACT <b>unclassified</b>	c. THIS PAGE <b>unclassified</b>			

- **Capability Improvements Needed**

- The United States' military technological superiority is being challenged ... This is not a future problem, nor is it speculative. My concerns are based on the intelligence reports I have received on a daily basis for almost five years.

—Hon. Frank Kendall

Under Secretary of Defense for  
Acquisition Technology & Logistic,  
December 2014



- **Systems must be updated quickly for CYBERSAFE**
  - Cybersecurity standards must be applied & re-applied to every system throughout its service life, not just at initial acquisition. Once it delivers, even if it delivers perfectly — zero vulnerabilities, zero attack surface — the *next day*, it will be vulnerable because of a new discovery, a new zero day [exploit].
    - VADM Jan Tighe, Commander, 10<sup>th</sup> Fleet, 20 April 2015



# The Naval Business Model – Top-Level Strategy

## Procure Basic Platforms

- Decouple the mission systems & integration from the platform
- Able to quickly change modular components for future flexibility
- Stabilize platform production – segregate from rapid change

## Develop/Maintain Capability Product Lines

- Reduce & manage vendor-locked & stove-piped products
- Improve core competencies across the force
- Design for robust, affordable testing
- Build in adaptability

## Integrate & Deliver

- Manage Platform-unique elements
- Reduce acquisition cost & risk
- Spur innovation & enhance warfighter capability

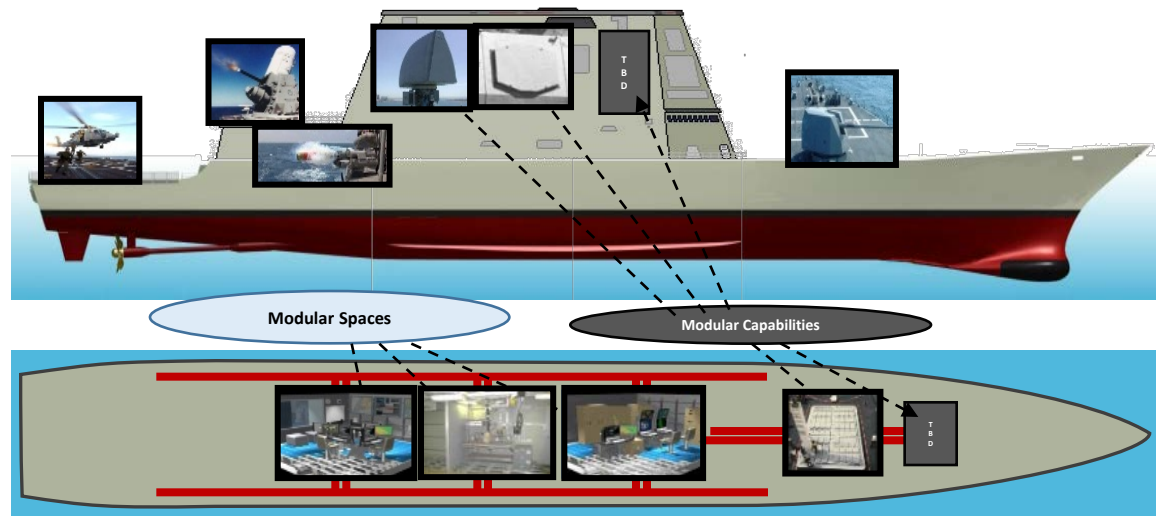

## Procure Basic Platforms

- Decouple the mission systems & integration from the platform
- Able to quickly change modular components for future flexibility
- Stabilize platform production – segregate from rapid change

## Develop/Maintain Capability Product Lines

- Reduce & manage vendor-locked & stove-piped products
- Improve core competencies across the force
- Design for robust, affordable testing
- Build in adaptability

## Integrate & Deliver

- Manage Platform-unique elements
- Reduce acquisition cost & risk
- Spur innovation & enhance warfighter capability

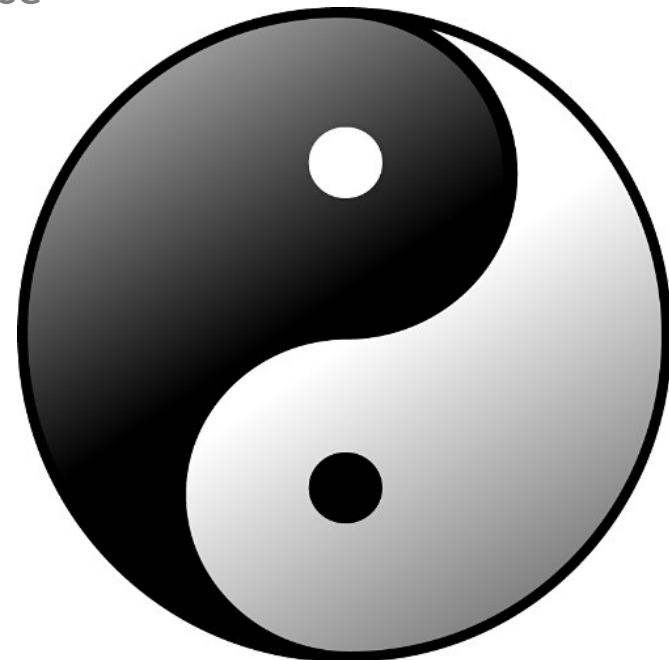

# Naval Open Systems Architecture (OSA) Strategy

O·S·A

## Open Systems Architecture Strategy

### Introduction

The current Naval Enterprise acquisition model is centered on highly integrated platforms with systems that are largely vendor locked, and expensive to acquire and upgrade. This model is especially problematic in the current economic environment.

The Naval Open Systems Architecture (OSA) strategy will decompose monolithic business and technical designs into manageable product lines composed of competition driven, modular Enterprise components. This will yield innovation, reduced cycle time, and lower total ownership costs.

### The New Naval Enterprise OSA Strategy:

The Naval OSA Strategy is an iterative set of business and technical changes that points to an end state where affordable, open platforms easily accommodate open modules. As the Navy moves toward this future, the Enterprise must first align itself to become open, modular, common, competitive, and ultimately, affordable. It will begin by implementing change in a coordinated fashion across all programs.

The Naval OSA Enterprise Team will lead the execution of this strategy with the participation of stakeholders (e.g., Resource Sponsors, PEOs, TWAs, etc.) as follows:

- Implement the coordinated set of business changes that improve competition, incentivize better performance, and deliver capability more rapidly;
- Construct a limited number of technical reference frameworks to immediately support improved competition and ultimately enable enterprise re-use;
- Develop an Execution Guidebook for this strategy; and
- Lead and guide training the workforce on OSA implementation.

Once these changes have been adopted at the program level, a second iteration (Figure 1) will prepare the Enterprise to eliminate redundancy and deliver open systems with reusable modules.

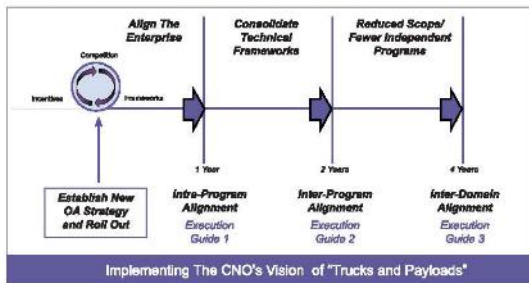

Figure 1. Iterative Naval OSA Strategy

Open Systems Architecture (OSA) Strategy

- **Technical Reference Frameworks (TRFs)**
  - Defined & managed by Government/Industry consortia
  - Used across multiple air, surface, submarine & ground platforms
  - Risk Prudent, modular competition
  - Access to innovation & timely deployment of improvements
- **Open Product Lines**
  - Implement TRFs using open standards
- **An IP Strategy that breaks down barriers to entry**
  - Developing for DoD is safe
  - Protect industry investments
  - Protect Government from Vendor-Lock
- **The Navy can build on its experience in building open & common systems**



See [acc.dau.mil/osastrategy](http://acc.dau.mil/osastrategy)

Emphasis is on both business & technology innovations

# Industry Trend - Common Platforms

Top 12 OEMs	2010	2020
Automobile platforms	223	154
Units based on 10 ten core platforms (millions)	17	33
Units based on OEM core platforms	39%	95%
3 core platforms or less per OEM		

**Common platforms have proven track record to reduce cost & time to market**

## Top 10 global megaplatforms

Forecast volume and number of models for 2017

OEM	Platform	Volume (in mn)	No. of Models	Sample models
1. VW	MQB	6.3	41	VW Golf, Passat; Audi A3
2. Toyota	MC	5.2	25	Auris, Corolla, Vibe; Scion xB
3. Hyundai/Kia	HD	3.0	16	Hyundai i30; KiaCee'd
4. GM	Delta	2.5	19	Opel Astra; Chevrolet Cruze
5. PSA	EMP2	2.3	24	Peugeot 308; Citroen C4, DS4
6. Renault/Nissan	B	2.2	10	Renault Clio; Nissan Cube, Juke, Leaf
7. Ford	C1	2.2	18	Focus, C-Max, Kuga
8. Hyundai/Kia	PB	1.9	18	Hyundai i20; Kia Rio, Venga
9. Renault/Nissan	CMF1	1.9	20	Renault Megane, Nissan Qashqai
10. Ford	B2E	1.8	11	Fiesta, B-Max; Mazda2/Demio
<b>Subtotal</b>		<b>29.4</b>	<b>202</b>	

Source: IHS Automotive, AlixPartners analysis

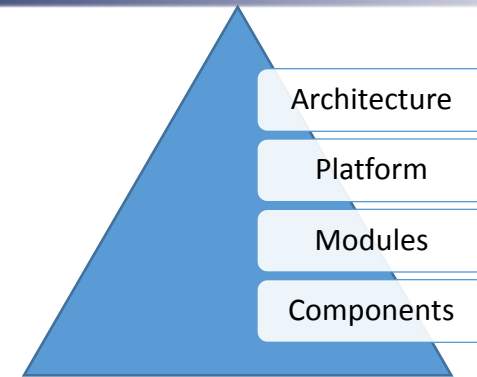

## VW MQB Common Platform



# Product-Line Benefits in Action

BEFORE

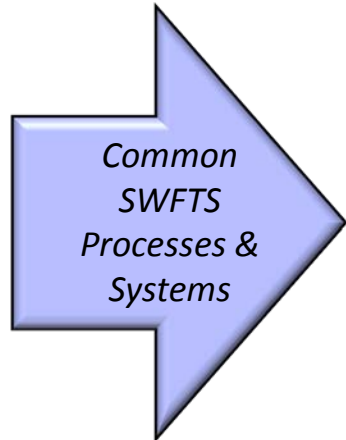
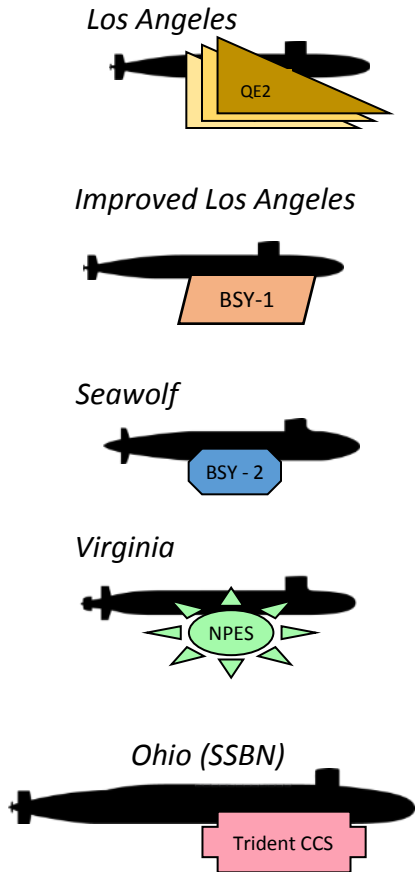

AFTER

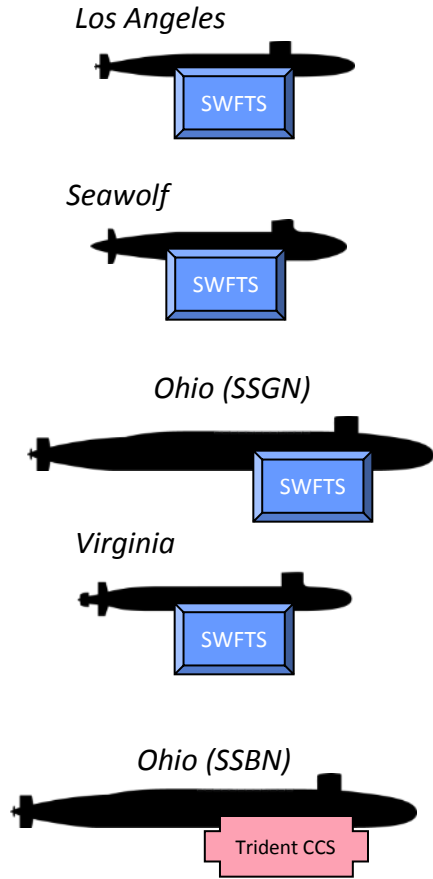

FUTURE

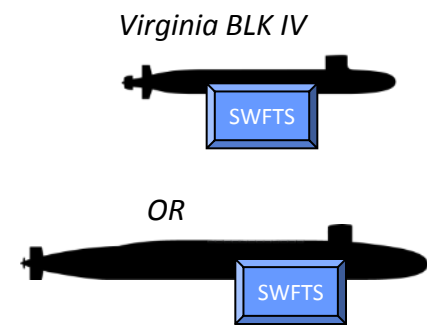

Submarine Classes Contain the Same Product-Line Subsystems  
Five independent support infrastructures consolidated & continuously improved

# A Holistic OSA Product-Line Strategy

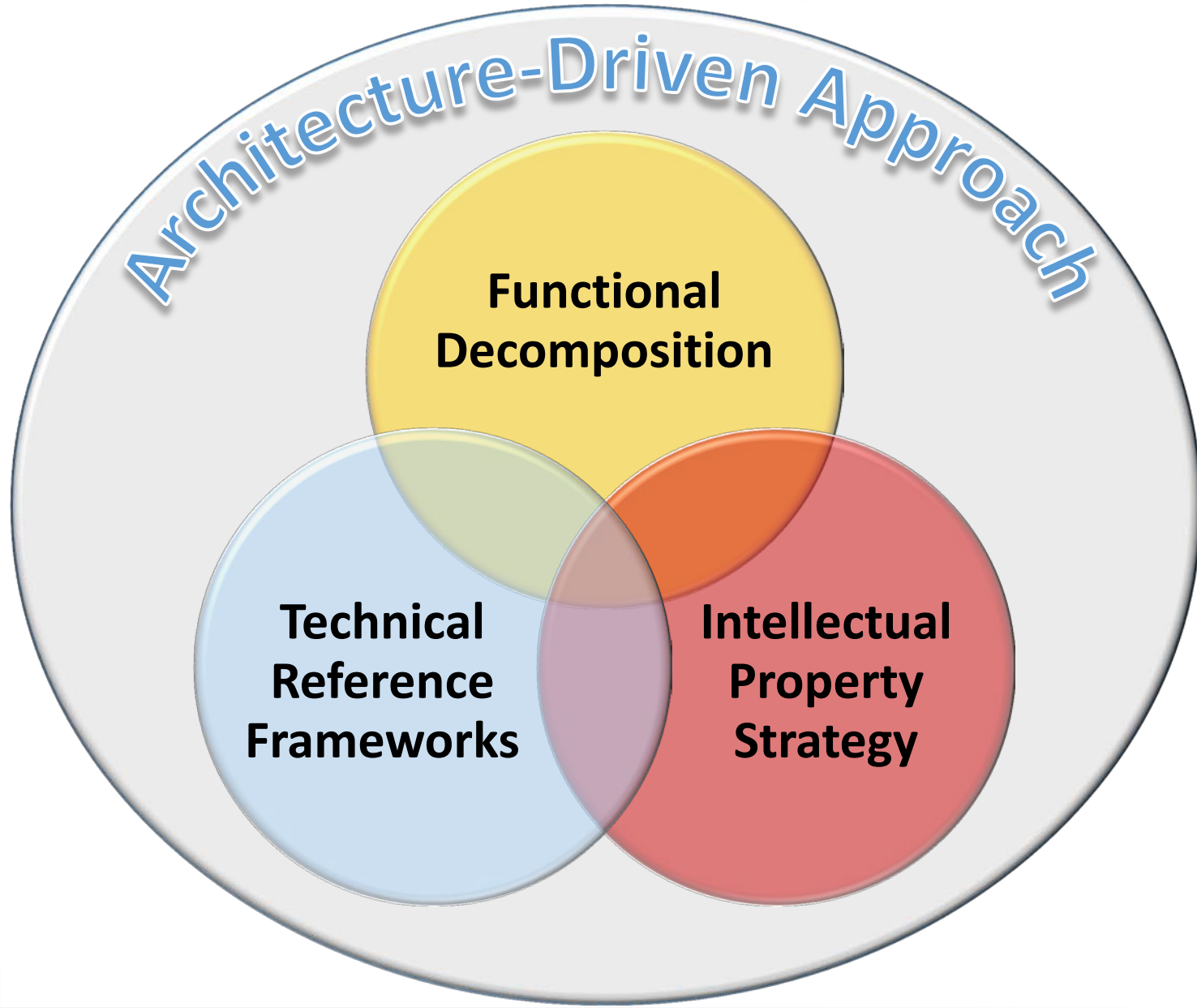

# Modular Unit Functional Decomposition

- Decompose & modularize functional capabilities
- Module contains minimum functionality suitable for enabling upgrades, competitive acquisition & cross-system portability
- Assess modular capabilities for suitability for commoditization
- Due to the depth & breadth of the modularization effort, it will be an ongoing effort over the course of multiple years
- Modularizing common capabilities enables development product lines for deliberate capability reuse

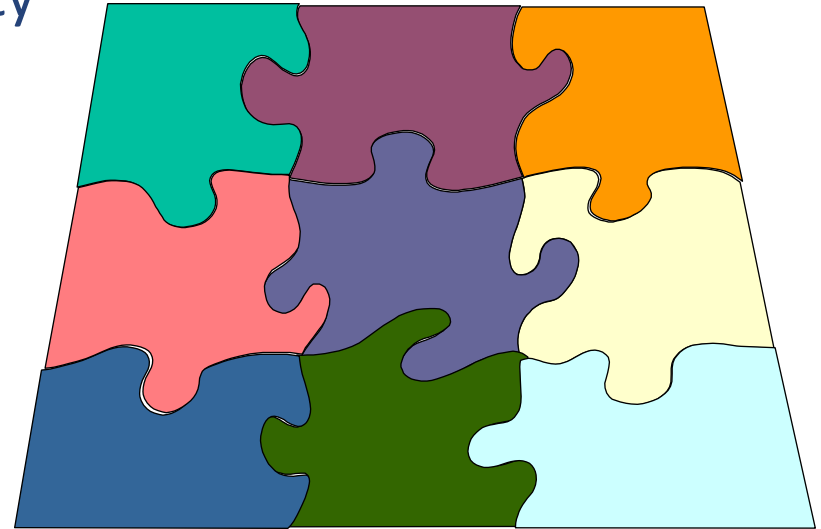

# Mission Area Capability Management



## Integrated Warfighting Capability (IWC) Enterprise Team



The Triad

FLEET FORCES / COTF / MARFORCOM  
Operational/Mission Need (Desired Effect / CONOPS)



Prepare/C	Search/	Locate/	Classify	Engage/	Engage/	Assess	Defend
Configure	Detect	Track		Launch	Weapon		
UAS	UAS	UAS	F-35A	F-35A	MK-54	F-35A	DDG
F-35A	F-35A	HH-60R	DDG	DDG	MK-48	DDG	LCS
DDG	DDG	DDG	LCS	LCS		LCS	HH-60R
LCS	LCS	LCS	HH-60R	HH-60R		HH-60R	SSN
SSN	SSN	SSN	SSN	SSN		SSN	

Potential Effects Chain

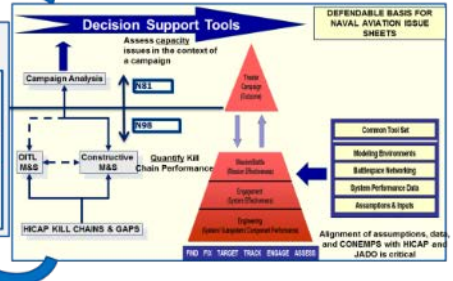

## Mission Technical Baseline - solution agnostic

- Timeframe, Location, Risk, Threat, Commanders Intent, Desired effects

## Integrated Capability Technical Baseline (ICTB) (SoS requirements, interfaces & standards)

- Capability, Affordability, Timeline Trade Space analysis

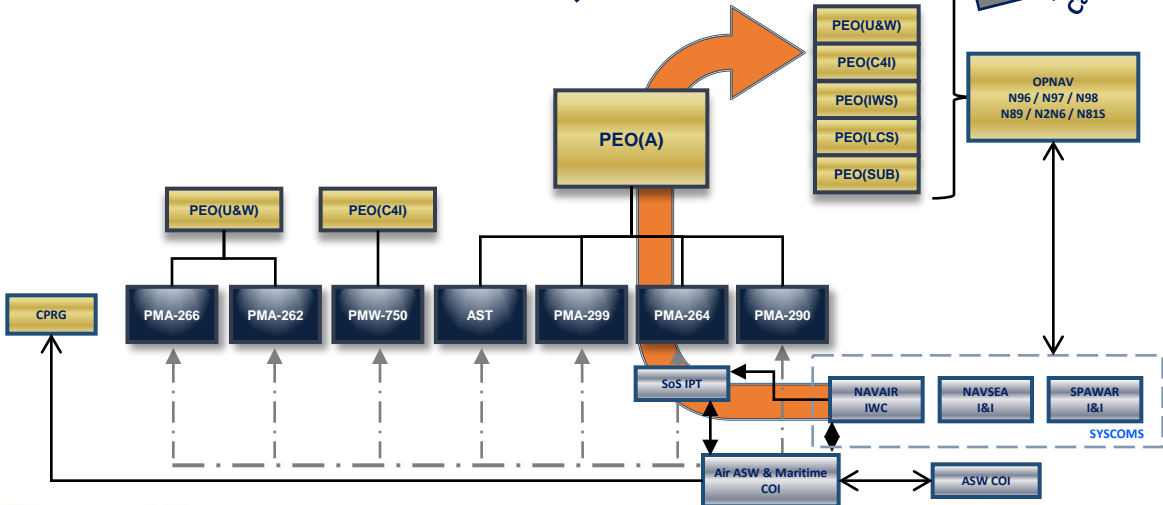
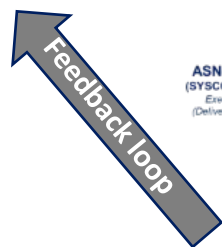

**Deliver warfighting affordable, integrated, & interoperable capabilities using open & standard processes & tools**

# Product Line Determination Method

Modules defined during Functional Decomposition fall into one of four categories:

1. Common across a number of platforms & should be commoditized for savings via reuse
2. Capture/define important external interfaces & should be commoditized with a goal of increased interoperability through commonality
3. Very high rate of change & program specific
4. Truly program unique & unchanging

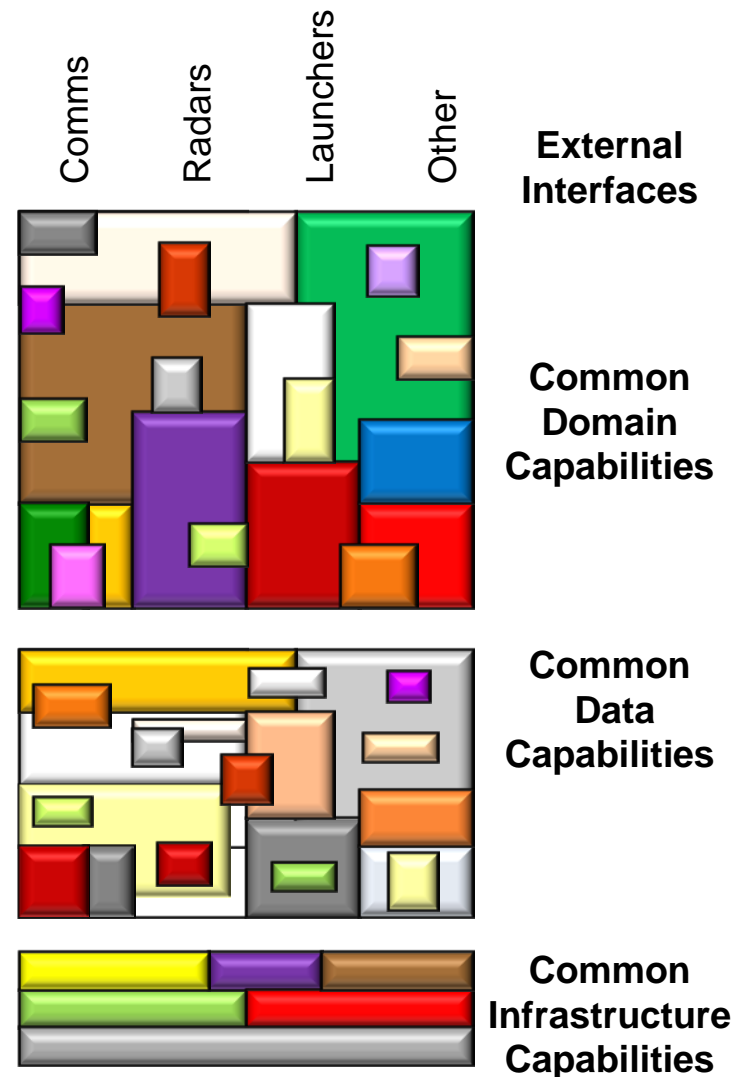

# Technical Reference Frameworks (TRFs)

- TRFs are key to use of OSA
  - e.g., FACE, UCS, HOST, & SPIES
- Navy has various uncoordinated TRFs at varying maturity levels
- Enterprise approach applies TRFs to enable Open Product Lines
- Must account for programmatic realities
  - New programs would use them
  - Legacy programs need to determine which TRFs to use & when
- TRFs need enterprise approach to ensure benefits & compliance

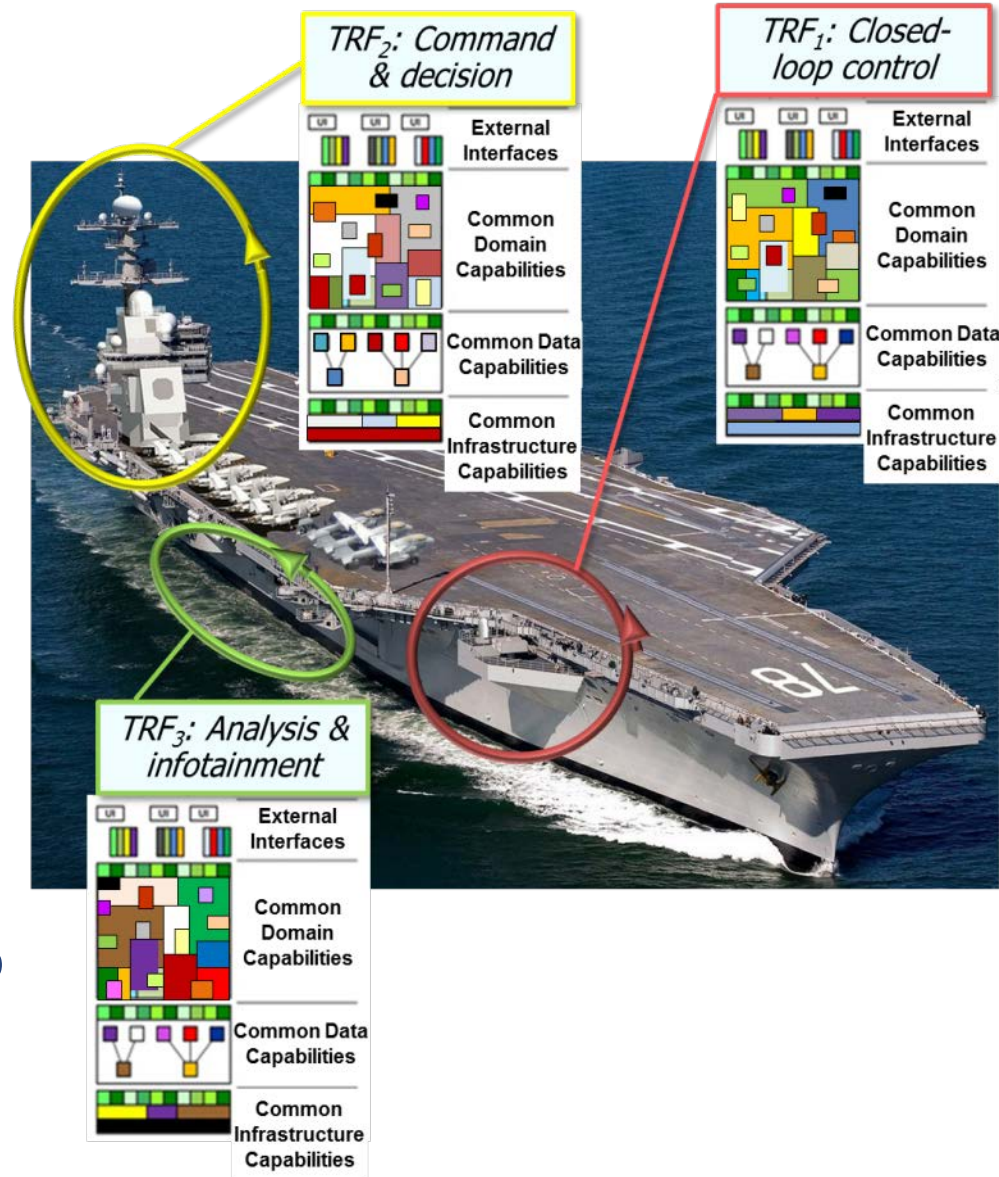

The 2<sup>nd</sup> Step in Implementing an OA Strategy is the Strategic Use of TRFs

# FACE – a Gov't led, Industry Supported TRF

## Key attributes

- *Crisply defined software & system technical architecture*
- TRFs enable competition at multiple system levels

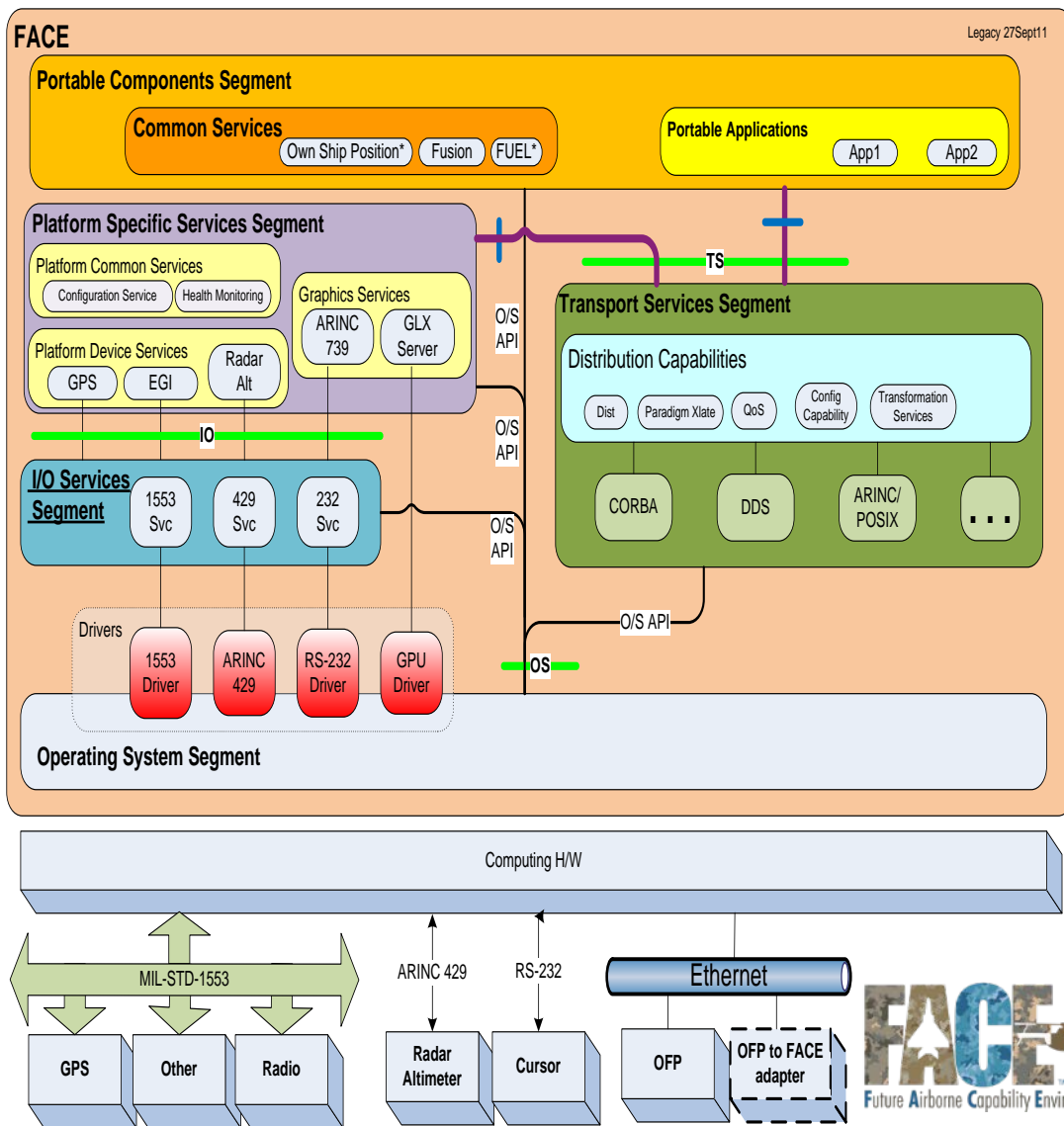

# FACE – a Gov't led, Industry Supported TRF

## Key attributes

- *Crisply defined software & system technical architecture*
- *Modular innovation potential*
  - Economically-guided criterion for (de)composing TRFs into modules

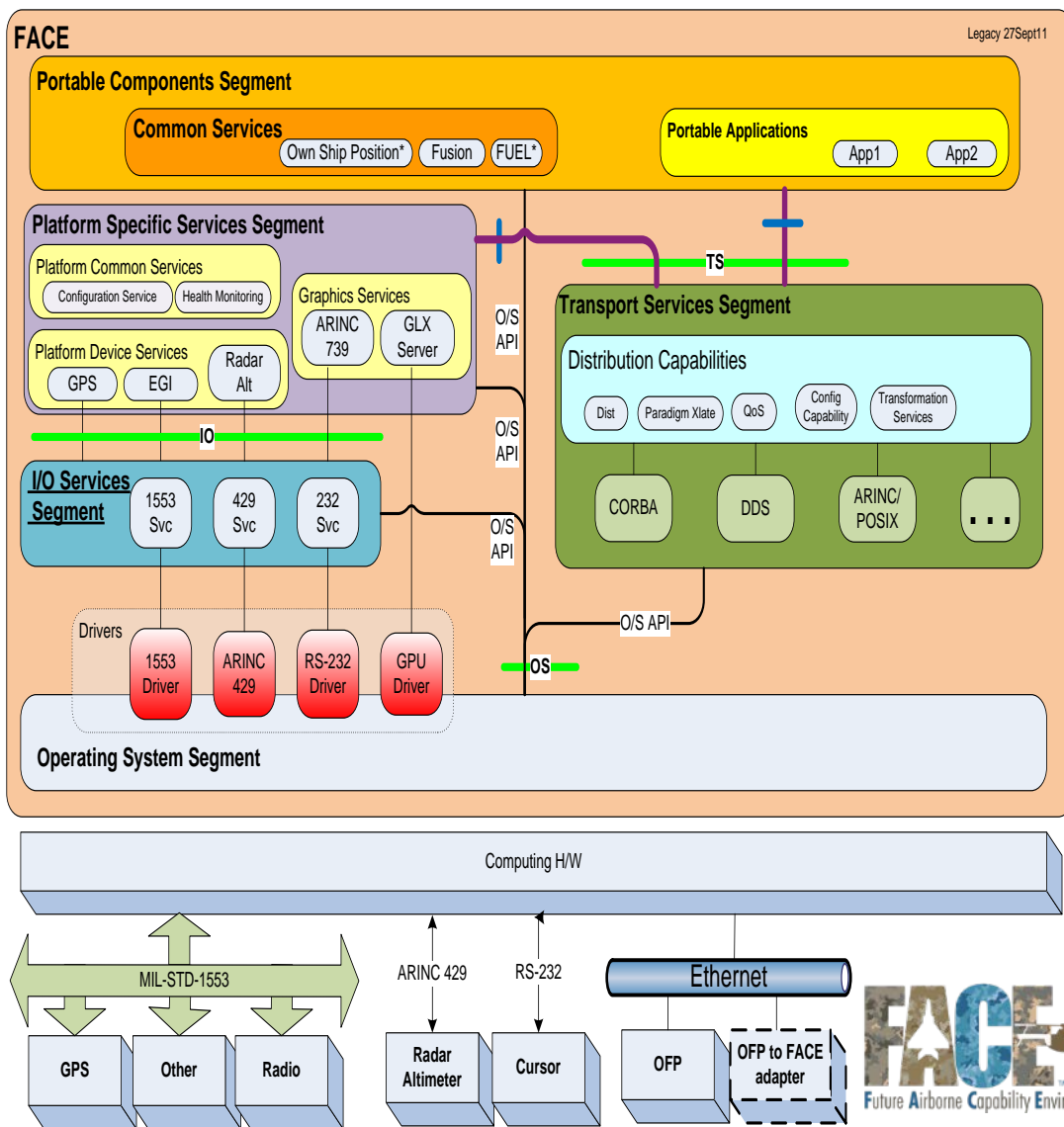

# FACE – a Gov't led, Industry Supported TRF

## Key attributes

- *Crisply defined software & system technical architecture*
- *Modular innovation potential*
- *Competitive evolutionary procurement processes*
  - Enable improvements throughout acquisition program lifecycles
  - Not just at infrequent down-selects

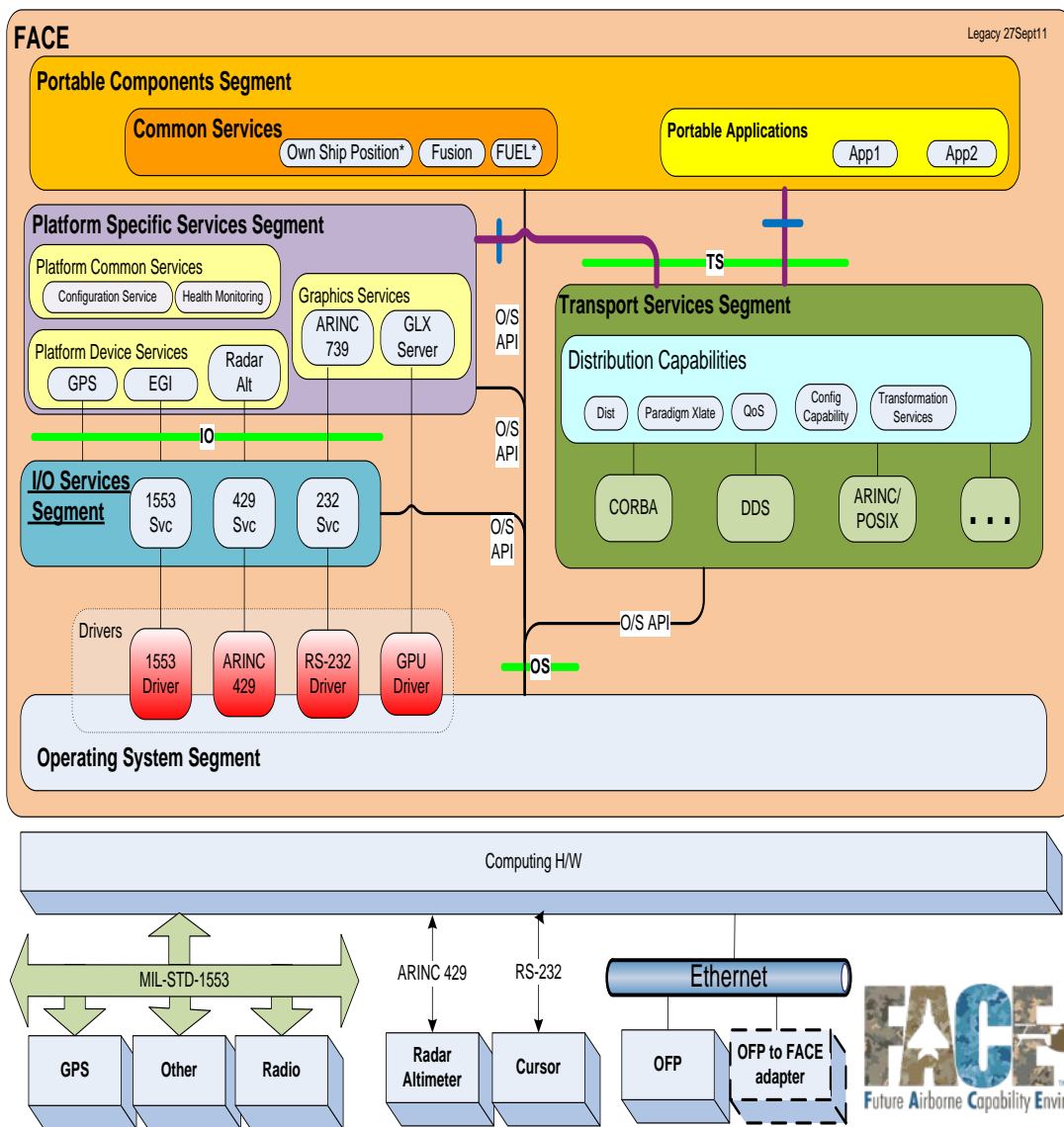

True competition requires robust interoperable open system architectures

# Enterprise Management Objectives

AIR



C4I

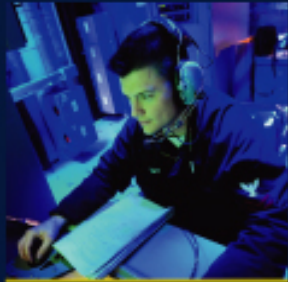

MARINES



SPACE



SUBS



SURFACE



- To achieve enterprise level savings via economy-of-scale, efficiencies, & systematic reuse of common assets
- To oversee development of TRFs & Open Product Lines
- To oversee the program's cut-in plans for TRFs & Open Product Lines
- To evolve over time & across program lifecycles



**The 3<sup>rd</sup> Step in an OSA Strategy is Adoption of Open Product Lines for the Enterprise**

# Open Acquisition Intellectual Property Strategy

- Government as Business Integrator
- Choose where to invoke license rights to design data
  - Architecture & interfaces
  - What the Government paid to develop
- Choose where to invoke innovation
  - Where warfighting requirements change quickly
  - Where the Commercial sector is investing
  - Where there are multiple strong providers

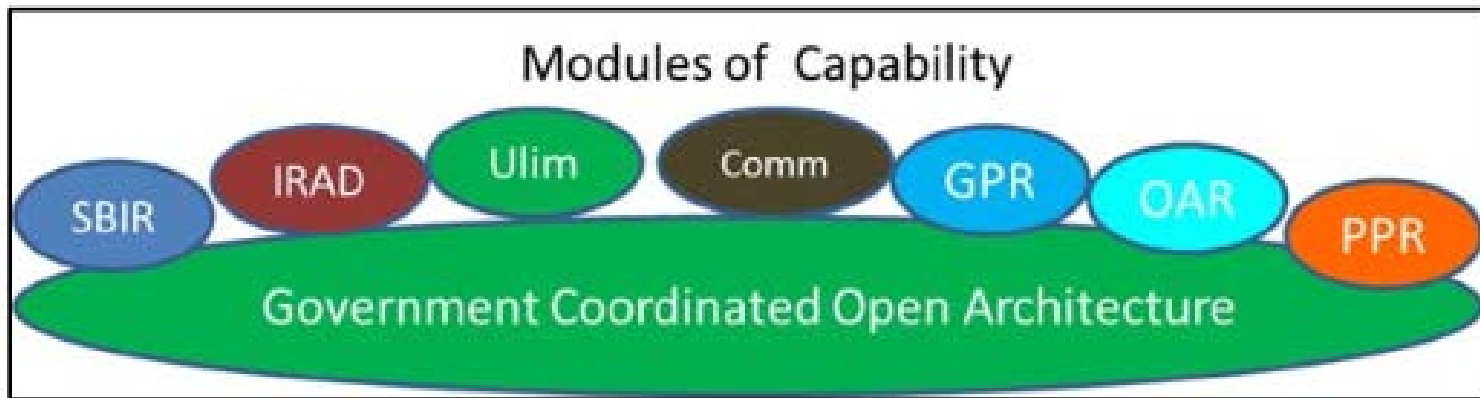

# IP Strategy for an Open Product Line

## Competition Across the Lifecycle

- Competition for O-C
- Replacement for R-P



CONTRACTS

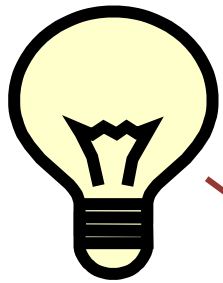
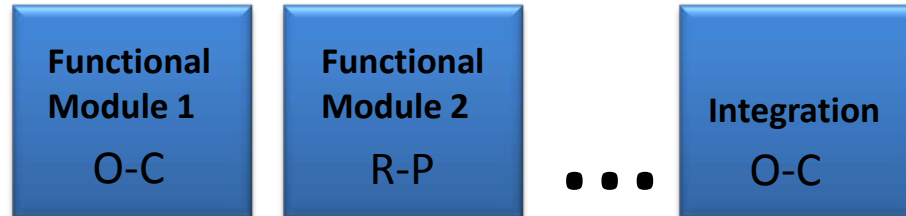
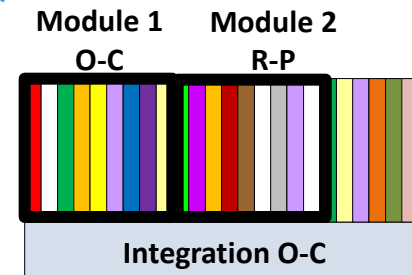

TECHNOLOGY

REQUIREMENTS



WARFIGHTER

# Benefits of Open Product Lines

## Business

1. Competition for components & integration services
2. International cooperation & foreign sales opportunities
3. Wider array of providers for upgrades
4. Open currently closed markets
5. Common capabilities used across multiple platforms

## Technical

1. Common training, operations & maintenance
2. S&T risk reduction and & focus on new value
3. More robust application of CYBERSAFE techniques
4. Risk reduction for transition of new technologies
5. Consolidation of infrastructure



**We need both business & technology innovations**

# Mapping How We Get There

