

**GOATS'2000**  
**Multi-AUV Cooperative Behavior**  
**Multi-scale Environmental Assessment**

Henrik Schmidt  
Department of Ocean Engineering  
Massachusetts Institute of Technology  
Cambridge, MA 02139  
Phone: (617) 253-5727    Fax: (617) 253-2350    E-mail: [henrik@keel.mit.edu](mailto:henrik@keel.mit.edu)

Award Number: N000149710202  
<http://acoustics.mit.edu/arctic0/henrik/www/home.html>

## **LONG-TERM GOAL**

Develop environmentally adaptive sonar concepts for autonomous underwater vehicle networks for detection and classification of proud and buried targets in very shallow water.

## **OBJECTIVES**

The objective of this sub-project is to develop the fundamental technology for operating multiple autonomous underwater vehicles in a coordinated, cooperative manner within the AOSN framework, with application to mine countermeasures and rapid environmental assessment in shallow and very shallow water.

## **APPROACH**

The development of GOATS (Generic Ocean Array Technology Sonar) is a highly interdisciplinary effort, involving experiments, and theory and model development in advanced acoustics, signal processing, and robotics. The center piece of the research effort is the GOATS'2000 Joint Research Program (JRP) conducted by SACLANTCEN and MIT with ONR support, which was scheduled to finish in Aug. 2001, but which has been extended with 5 years, formally incorporated in the SACLANTCEN Program of Work. Building on the experience of the highly successful GOATS'98 pilot experiment [2] and the GOATS'2000 [9] experiment, the JRP continues with a series of experiments, with the two major ones being planned for 2002 and 2004, and modeling and simulation work to explore the potential of autonomous underwater vehicle networks as platforms for new sonar concepts exploring the full 3-D acoustic environment of VSW. The modeling effort is centered around the OASES environmental acoustic modeling framework developed at MIT [1,4]. OASES is a widely distributed suite of models covering a variety of ocean waveguide and source/receiver representations. Thus, the most recent developments are computational modules for full wave theory modeling of mono- and bistatic reverberation in shallow water waveguides. In collaboration with SACLANTCEN the waveguide reverberation code OASSP has been modified to consistently model the mono- and bistatic reverberation from interface roughness and seabed volume inhomogeneities in azimuthally symmetric sonar scenarios [6]. Another module, OASES-3D provides wave-theory modeling of the full 3-D acoustic environment associated with mono- and bi-static configurations in VSW with aspect-

# Report Documentation Page

*Form Approved*  
*OMB No. 0704-0188*

Public reporting burden for the collection of information is estimated to average 1 hour per response, including the time for reviewing instructions, searching existing data sources, gathering and maintaining the data needed, and completing and reviewing the collection of information. Send comments regarding this burden estimate or any other aspect of this collection of information, including suggestions for reducing this burden, to Washington Headquarters Services, Directorate for Information Operations and Reports, 1215 Jefferson Davis Highway, Suite 1204, Arlington VA 22202-4302. Respondents should be aware that notwithstanding any other provision of law, no person shall be subject to a penalty for failing to comply with a collection of information if it does not display a currently valid OMB control number.

1. REPORT DATE <b>30 SEP 2001</b>	2. REPORT TYPE	3. DATES COVERED <b>00-00-2001 to 00-00-2001</b>			
4. TITLE AND SUBTITLE <b>GOATS-2000 Multi-AUV Cooperative Behavior Multi-scale Environmental Assessment</b>		5a. CONTRACT NUMBER			
		5b. GRANT NUMBER			
		5c. PROGRAM ELEMENT NUMBER			
6. AUTHOR(S)		5d. PROJECT NUMBER			
		5e. TASK NUMBER			
		5f. WORK UNIT NUMBER			
7. PERFORMING ORGANIZATION NAME(S) AND ADDRESS(ES) <b>Department of Ocean Engineering,,Massachusetts Institute of Technology,,Cambridge,,MA, 02139</b>		8. PERFORMING ORGANIZATION REPORT NUMBER			
9. SPONSORING/MONITORING AGENCY NAME(S) AND ADDRESS(ES)		10. SPONSOR/MONITOR'S ACRONYM(S)			
		11. SPONSOR/MONITOR'S REPORT NUMBER(S)			
12. DISTRIBUTION/AVAILABILITY STATEMENT <b>Approved for public release; distribution unlimited</b>					
13. SUPPLEMENTARY NOTES					
14. ABSTRACT <b>Develop environmentally adaptive sonar concepts for autonomous underwater vehicle networks for detection and classification of proud and buried targets in very shallow water.</b>					
15. SUBJECT TERMS					
16. SECURITY CLASSIFICATION OF:			17. LIMITATION OF ABSTRACT <b>Same as Report (SAR)</b>	18. NUMBER OF PAGES <b>9</b>	19a. NAME OF RESPONSIBLE PERSON
a REPORT <b>unclassified</b>	b ABSTRACT <b>unclassified</b>	c THIS PAGE <b>unclassified</b>			

dependent targets and reverberation features [3,4]. OASES-3D incorporates environmental acoustic features specifically associated with bi-static sonar concepts in shallow water, including aspect-dependent target models, seabed porosity, and scattering from anisotropic seabed roughness such as sand ripples. The validation of these models is one of the major objectives of the GOATS JRP with SACLANTCEN.

The environmental assessment is critical to advanced sonar concepts and is achieved by combining the Autonomous Ocean Sampling Network (AOSN) with a nested modeling and assimilation framework centered around the CUPOM (University of Colorado) and Harvard Ocean Prediction System (HOPS), nested within available basin-scale models, implemented and operated as part of the GOATS'2000 experiment.

## WORK COMPLETED



*Fig. 1. (a)GOATS'2000 range in Biodola Bay, Elba, with TOPAS parametric projector and bottom mounted targets and natural seabed ripple fields. (b) Deployment of Oddyse bistatic receiver AUV from RV Alliance, Sep. 25, 2000.*

The most significant component of the FY01 has been associated with the execution of the GOATS'2000 experiment in Golfo di Procchio, Elba Island, carried out as a Joint Research Project (JRP) with SACLANT Undersea Research Centre in the period Sep. 18 – Oc. 14, 2000. The experiment collected a variety of oceanographic and navy resources for performing rapid environmental assessment (REA) and mine countermeasures (MCM) in shallow (SW) and very shallow water (VSW). A fleet of 4 AUV's were operated from R/V Alliance. One MIT Odyssey II was equipped with an 8-element acoustic array in a 'swordfish' configuration serving as bistatic receiver for measuring the 3-D scattering from natural ripple fields and aspect dependent targets deployed on and within the seabed. The seabed was insonified by a TOPAS parametric source on a stationary tower. In addition, a second Odyssey II AUV was equipped with an Edgetech subbottom profiler which to be used as a moving bistatic source and for REA missions. This AUV was successfully configured and prepared for these missions, but the dual vehicle missions were not successfully completed due to mechanical and electrical failures in this vehicle.

A third AUV, an FAU Ocean Explorer was equipped with a sidescan system for seabed mapping and multiaspect target classification. This vehicle was successfully operated by FAU and SACLANTCEN.

Finally, a Taipan AUV is operated by a group from LIRMM in France as part of the MIT effort, collecting CTD data in Procchio Bay. This data is assimilated into a nested ocean forecasting framework together with CTD, XCTD, and XBT data collected by R/V Alliance during nighttime operations.

The MEANS (Multiscale Environmental Assessment Studies) component of the GOATS'2000 cruise started Sep. 18, 2000, initiated with oceanographic sampling of the Ligurian Sea during the first 5 days of the cruise. This data was assimilated into HOPS and UC models to initiate the forecasts. During the remaining part of the experiment, R/V Alliance will adaptively collect CTD, XCTD and XBT data in a pattern determined from the HOPS forecasts, and this data will together with data collected by the AUVs was downloaded via WWW by the modeling teams at Harvard and Columbia Universities and assimilated into the forecasts. The MEANS component was extremely successful, with the forecasts verified by direct measurements, and provided a unique littoral predictive skill demonstration, which will be followed up by another exercise in connection with the Joint GOATS REA experiment in May 2002.

**RESULTS**

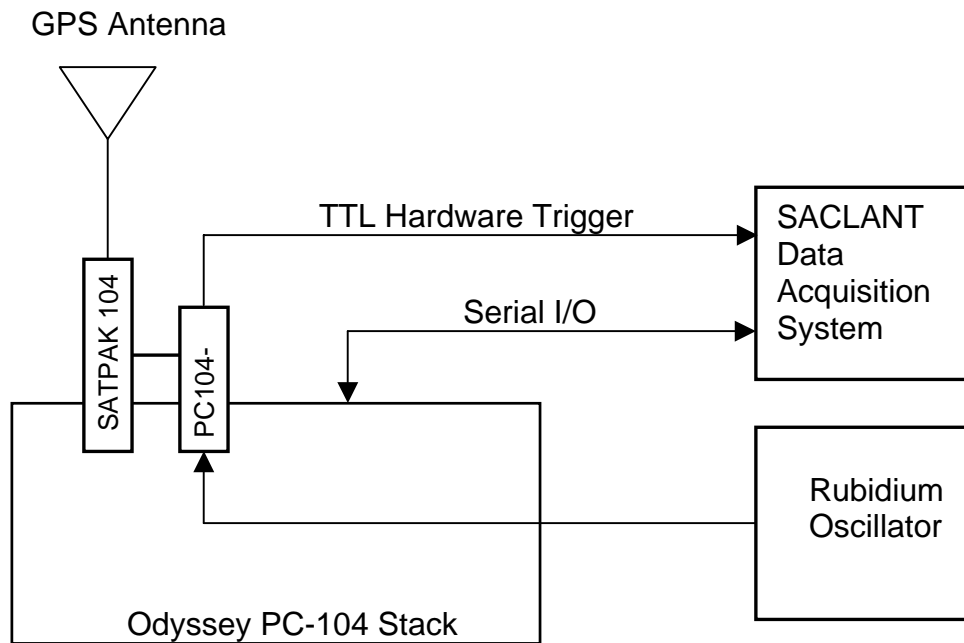

*Fig. 2. MIT Multi-AUV Time Synchronization System*

A number of major improvements of the Odyssey II vehicles and their acoustic configuration has been achieved under this project, in addition to major reconfigurations of the vehicles carried out under the general ONR AOSN effort, finishing this year.

First of all, GOATS'98 revealed a need to improve the time synchronization of the acoustic sources and the bistatic AUV receiving platforms. MIT has therefore developed a new Multi-Vehicle Precision

Time Synchronization with the capability of synchronizing the Odyssey time base to within 500 nanoseconds of UTC via GPS. While on the surface, all vehicle and ship/shore stations are synchronized with each other to within 1 microsecond of UTC. During dives the clock drift on Odyssey vehicle has been reduced to less than 1 microsecond/hour using a rubidium oscillator.

Another need identified in the GOATS'98 experiment was a capability to externally trigger the SACLANT data acquisition system on the Odyssey AUV. The approach developed allows for extremely accurate (< microsecond) recording of acoustic travel times, enhancing processing performance substantially compared to the earlier experiment. Figure 2 shows a diagram of the MIT Ultra-Precision Time Synchronization system that was used to synchronize the Odyssey vehicle to the GPS reference time and to trigger the SACLANT data acquisition system in GOATS 2000.

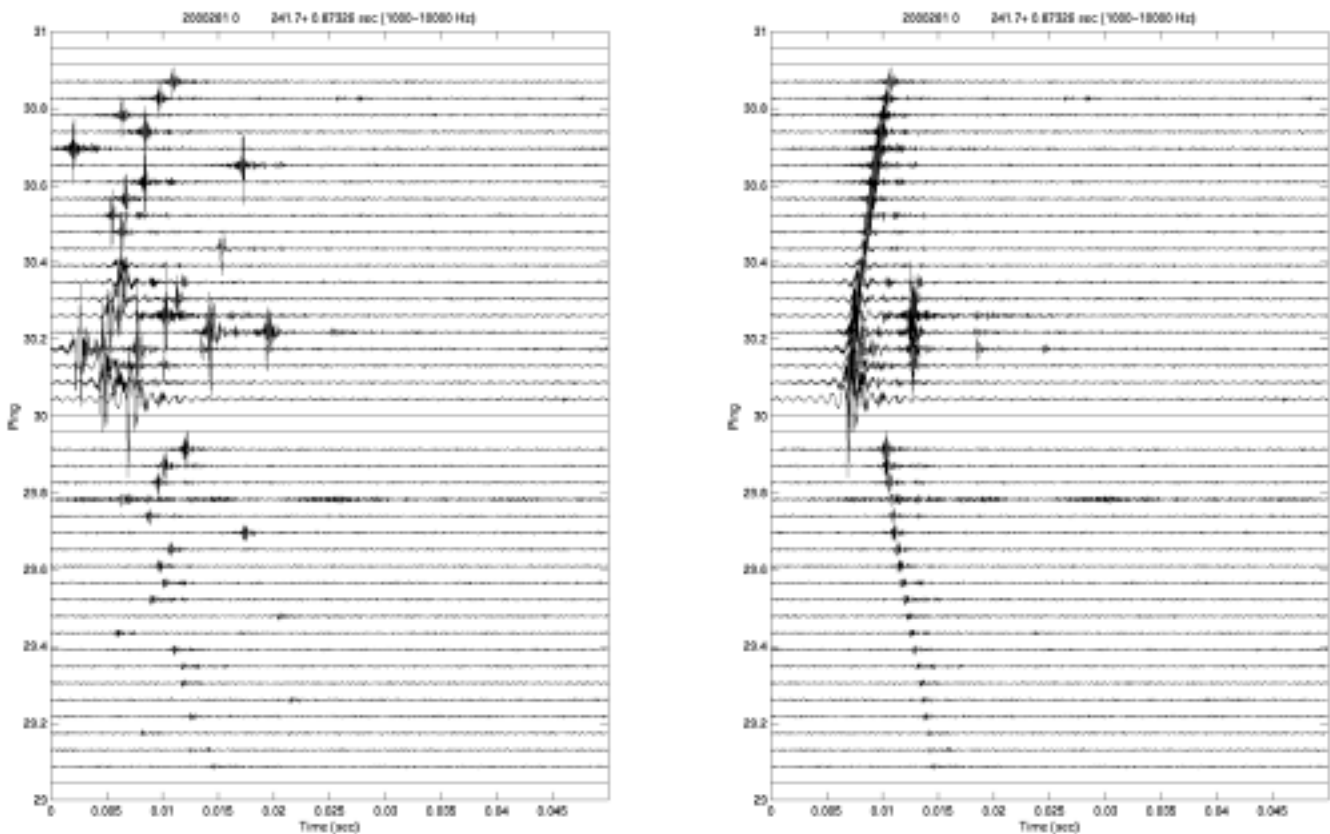

***Fig. 3. Time Synchronization Results for GOATS 2000***

To allow for coordinated AUV operations needed for bistatic configurations, MIT has developed together with the acoustic communication group at Woods Hole a capability to transmit real-time telemetry to and from multiple operating Odyssey vehicles and ship/shore stations, and between vehicles.

This development is critical to adaptive cooperation between multiple operating Odyssey vehicles. During the GOATS 2000 experiment, telemetry between an Odyssey vehicle and the ship was

demonstrated successfully. Due to the failure of the second Odyssey vehicle, the inter-vehicle communications was not tested. This capability will be demonstrated in the GOATS 2002 experiment.

One additional challenge arose during execution of the GOATS '00 experiment due to the fact that many of the sensors, communications, and navigation systems made use of the acoustic channel and all used the same frequency range. This challenge was overcome by implementing an expert system based scheduling algorithm for each of the affected systems such that each system had use of the acoustic channel on a non-interference basis for its own period of time.

Finally, GOATS'98 revealed a need for improved LBL navigation for performing coherent synthetic aperture processing. Enhanced navigation has been achieved by integrating a new Kalman filter-based long-baseline (LBL) navigation algorithm into the Odyssey vehicle. This was achieved in collaboration with J. Vaganay at LIRMM, France.

## **IMPACT/APPLICATION**

The long-term impact of this effort is the development of new sonar concepts for VSW MCM, which take optimum advantage of the mobility, autonomy and adaptiveness of the AOSN. For example, bi- and multi-static, low-frequency sonar configurations are being explored for buried mines in VSW, with the traditional high-resolution acoustic imaging being replaced by a 3-D acoustic field characterization as a combined detection and classification paradigm, exploring spatial and temporal characteristics which uniquely define the target and the reverberation environment.

## **TRANSITIONS**

The GOATS AUV effort has been and is conducted by the MIT Sea Grant AUV Laboratory, in part funded by this project and the AOSN MURI. A new AUV enterprise, Bluefin Robotics, is a spin-off from the MIT Laboratory, and is currently developing a new Odyssey III Battlefield Preparation AUV for ONR, building in part of experience from the GOATS'98 experiment [2].

The 3-D acoustic models for VSW MCM environments developed under GOATS are being integrated in a multi-AUV simulation capability developed by the MIT Sea Grant AUV Laboratory and Bluefin Robotics under the ONR project (Code 321TS) "Sensor and Operational Tradeoffs for Multiple AUV MCM" (N00014-99-1-0851). Also, the simulation capability is being utilized and augmented under the ONR SBIR (code 321OE) "USBL Positioning of Littoral Swarm Systems" (N00014-97-C-0288) in collaboration with IS Robotics.

The OASES code continues to be maintained and expanded. It is continuously being exported or downloaded from the OASES web site (<http://acoustics.mit.edu/arctic0/henrik/www/oases.html>), and used extensively by the community as a reference model for ocean seismo acoustics in general.

## RELATED PROJECTS

This effort is part of the US component of the GOATS`2000 Joint Research Project (JRP) with the SACLANT Undersea Research Centre. The MIT GOATS effort is funded by ONR codes 321OA (Simmen), 321OE (Swan), 321TS (Johnson), and 322OM (Curtin).

The GOATS effort is strongly related to the ONR Autonomous Ocean Sampling Network (AOSN) initiative. Thus the GOATS`98 experimental effort was funded in part by the AOSN MURI, (PI: J. Bellingham). In terms of the fundamental seabed penetration physics there are strong relations to the High-Frequency Bottom Penetration DRI (PI: E. Thorsos). This effort also builds on acoustic modeling efforts initiated under the Sea-Ice Mechanics Initiative (SIMI), and continued under funding from ONR code 321OA.

With its heavy focus on Synthetic Aperture Processing approaches and their extension to bi- and multistatic configurations in multipath SW VSW environments, there are strong relations to the ONR SASSAFRASS project (code 321TS and 321OA).

The OASES modeling framework being maintained and upgraded under this contract is being used intensively as part of the MIT AREA (Adaptive Rapid Environmental Assessment) component of the new ONR "Capturing Uncertainty" DRI (Grant # N0014-01-1-0817), aimed mitigating the effect of sonar performance uncertainty due to environmental uncertainty by adaptively deploying environmental assesment resources. Also, the very comprehensive MEANS dataset is expected to be applied in this project.

## REFERENCES

1. Schmidt, H. "OASES V 2.7 User's Guide", Massachusetts Institute of Technology, 2000.
2. Schmidt, H., Maguer, A, Bovio, E., Fox, W.L.J., LePage, K., Pace, N.G., Hollett,R., Guerrini, P., Sletner, P.A., Michelozzi, E., Moran, B. and Grieve, R. "GOATS`98 – AUV Network Sonar Concepts for Shallow Water Mine Countermeasures," *SACLANT Undersea Research Centre*, Report SR-302, 1998.
3. Lee, J. "Multi-static scattering of targets and rough interfaces in ocean waveguides," *Ph.D. Thesis, Massachusetts Institute of Technology*, February, 1999.
4. Schmidt, H. and Lee, J.Y, "Physics of 3-D scattering from rippled seabeds and buried targets in shallow water," *Journal of the Acoustical Society of America*, 105(3), 1605-1617, 1999.
5. Schmidt, H. Three-dimensional scattering from buried targets in shallow water. *In: Bovio, E., Schmidt, H., editors. GOATS 2000, SACLANTCEN CP-46*, 2001.
6. LePage, K. and Schmidt, H. "Spectral integral representations of scattering from volume inhomogeneities in ocean waveguides," *Journal of the Acoustical Society of America*, **108**, 2000:1557-1567.

7. Maguer, A., Bovio, E., Fox, W.L., Pouliquen, E. and Schmidt, H., "Mechanisms for subcritical penetration into a sandy bottom: Experimental and modeling results," *Journal of the Acoustical Society of America*, 1215-1225, 2000.
8. Maguer, A., Bovio, E., Fox, W.L., and Schmidt, H., "In situ estimation of sediment sound speed and critical angle," *Journal of the Acoustical Society of America*, 108(3): 987--996, (2000) .H. Schmidt and E. Bovio, "Underwater vehicle networks for acoustic and oceanographic measurements in the littoral ocean," *Proceedings: International Conference on Maneuvering and Control of Marine Craft*. International Federation for Automation and Control, Aalborg, Denmark, Aug. 23-25, 2000.
10. Tesei, A., Lim, R., Maguer, A., Fox, W.L.J., Schmidt, H. Measurements of acoustic scattering from partially and completely buried spherical shells. *Journal of the Acoustical Society of America* Submitted, 2001.

## PUBLICATIONS

LePage, K.D., Schmidt, H. Spectral integral representations of volume scattering in sediments in layered waveguides. *Journal of the Acoustical Society of America*, **108**, 1557-1567, 2000.

Maguer, A., Bovio, E., Fox, W.L., and Schmidt, H., "In situ estimation of sediment sound speed and critical angle," *Journal of the Acoustical Society of America*, 108(3): 987--996, (2000) .

LePage, K., Schmidt, H. Bistatic synthetic aperture imaging of proud and buried targets using an AUV, *IEEE Journal of Oceanic Engineering* (Accepted for publication), 2001.

J. R. Edwards, H. Schmidt and K. LePage, Bistatic synthetic aperture target detection and imaging with an AUV, *IEEE Journal of Oceanic Engineering* (In press), 2001.

LePage, K., Schmidt, H. Spectral integral representations of monostatic backscattering from threedimensional distributions of sediment volume inhomogeneities. *Journal of the Acoustical Society of America*, (submitted), 2001.

Tesei, A., Lim, R., Maguer, A., Fox, W.L.J., Schmidt, H. Measurements of acoustic scattering from partially and completely buried spherical shells. *Journal of the Acoustical Society of America* (submitted), 2001.

Schmidt, H., Bovio, E. Underwater vehicle networks for acoustic and oceanographic measurements in the littoral ocean. *In: MCMC2000: 5th IFAC Conference on Manoeuvring and Control of Marine Crafts*, Aalborg, Denmark, 2000.

H. Schmidt, J.G. Bellingham, P. Elisseeff, "Synoptic mapping of coastal oceanography using acoustic tomography and autonomous underwater vehicles," *Proceedings: International Conference on Maneuvering and Control of Marine Craft*. International Federation for Automation and Control, Aalborg, Denmark, Aug. 23-25, 2000.

Schmidt, H., Edwards, J.R., LePage, K.D. Bistatic synthetic aperture sonar concept for MCM AUV networks. *In: International Workshop on Sensors and Sensing Technology for Autonomous Ocean Systems*, Kona, Hawaii, 2000.

Schmidt, H. Three-dimensional scattering from buried targets in shallow water. *In: Bovio, E., Schmidt, H., editors. GOATS 2000, SACLANTCEN CP-46*, 2001.

D. Egnor, P. Elisseeff, and H. Schmidt, "High-frequency quasi-reciprocal tomography in a high current coastal environment", In M.E. Zakharia, P. Chevret, P. Dubail, *editors*. Proceedings of the 5<sup>th</sup> European Conference on Underwater Acoustics, ECUA 2000, Lyon, France, pp. 163-169, 2000.

LePage, K.D., Schmidt, H. Laterally monostatic backscattering from three-3-D distributions of sediment inhomogeneities. *In: Zakharia, M.E., Chevret, P., Dubail, P., editors. Proceedings of the 5<sup>th</sup> European Conference on Underwater Acoustics, ECUA 2000. Lyon, France. pp. 1253-1258. 2000.*

Schmidt, H., Robinson, A., Kantha, L. MEANS: Multiscale environmental assessment network studies. *Journal of the Acoustical Society of America*, 108, 2000:2585:4aA03.

Edwards, J.R., Schmidt H., LePage, K.D. Bistatic target detection, interferometry, and imaging with an autonomous underwater vehicle platform. *Journal of the Acoustical Society of America*, 108, 2000:2484-2485:1pUW2.

Veljkovic, I., Schmidt, H. Experimental validation of numerical models of 3-D target scattering and reverberation in very shallow water. *Journal of the Acoustical Society of America*, 108, 2000:2485:1pUW3.

Schmidt, H., LePage, K.D. Spectral integral representations of multistatic scattering from sediment volume inhomogeneities. *Journal of the Acoustical Society of America*, 108, 2000:2564:3aUW14.

Schmidt, H., Kantha, L.H., Robinson, A.R. MEANS: multiscale environmental assessment network studies. *In: (unpublished) proposal for augmenting the GOATS JRP*, 1999.