

Annex II. TWSTFT link calibration with a GPS calibrator

Calibration reference: CI-888-2015

Version history: ZJ/V0/25Feb2015, V0a,b/HE/ZJ/7Mar; V0s/VZ9Mar; V0d,e,f+/DM10,17Mar; V1.0/1Apr; Final version 1Sept2015

TWSTFT link calibration report

-- Calibration of the Lab(k)-PTB UTC Time Links with a GPS calibrator¹

Héctor Esteban¹, Victor Zhang², Dirk Piester³, Demetrios Matsakis⁴, S.Y. (Calvin) Lin⁵, Zhiheng Jiang^{6*}

¹ ROA: Real Instituto y Observatorio de la Armada en San Fernando, hesteban@roa.es

² NIST: National Institute of Standards and Technology, 325 Broadway, Boulder, CO80305, US, victor.zhang@nist.gov

³ PTB: Physikalisch-Technische Bundesanstalt, 38116 Braunschweig, Germany, dirk.piester@ptb.de

⁴ USNO: United States Naval Observatory, 3450 Massachusetts Ave, NW, Washington DC 20392, US, demetrios.matsakis@usno.navy.mil

⁵ TL: National Standard Time and Frequency Laboratory, Telecommunication Laboratories, Chungghwa Telecom, sylin@cht.com.tw

⁶ BIPM: Bureau International des Poids et Mesures, zjiang@bipm.org

* Coordinator

Abstract

This report includes the calibration results of the Lab(k)-PTB TWSTFT link and closure measurements of the BIPM-Lab(k)-BIPM tour. During 10-20 Feb., 2015 (DOY 41-51, MJD 57063-57073), the BIPM Standard Travelling Calibration Station (Std_B) visited Lab(k) in order to calibrate the Lab(k)-PTB TWSTFT link for UTC generation. This work follows the TWSTFT Calibration Guideline for UTC Time Links [1].



The staff and the calibration setup at Lab(k)

¹ Annex II is neither mandated by the guideline [1] nor a part of it but gives an example how to perform a TWSTFT link calibration with a GPS calibrator and prepare the report. Acronyms (BIPM, USNO etc.), coordinator, equipment, images, figures, measurement data etc. in this document are *all fictional*.

Report Documentation Page

Form Approved
OMB No. 0704-0188

Public reporting burden for the collection of information is estimated to average 1 hour per response, including the time for reviewing instructions, searching existing data sources, gathering and maintaining the data needed, and completing and reviewing the collection of information. Send comments regarding this burden estimate or any other aspect of this collection of information, including suggestions for reducing this burden, to Washington Headquarters Services, Directorate for Information Operations and Reports, 1215 Jefferson Davis Highway, Suite 1204, Arlington VA 22202-4302. Respondents should be aware that notwithstanding any other provision of law, no person shall be subject to a penalty for failing to comply with a collection of information if it does not display a currently valid OMB control number.

1. REPORT DATE 01 SEP 2015		2. REPORT TYPE		3. DATES COVERED 00-00-2015 to 00-00-2015	
4. TITLE AND SUBTITLE TWSTFT link calibration report				5a. CONTRACT NUMBER	
				5b. GRANT NUMBER	
				5c. PROGRAM ELEMENT NUMBER	
6. AUTHOR(S)				5d. PROJECT NUMBER	
				5e. TASK NUMBER	
				5f. WORK UNIT NUMBER	
7. PERFORMING ORGANIZATION NAME(S) AND ADDRESS(ES) United States Naval Observatory, 3450 Massachusetts Ave, NW, Washington, DC, 20392				8. PERFORMING ORGANIZATION REPORT NUMBER	
9. SPONSORING/MONITORING AGENCY NAME(S) AND ADDRESS(ES)				10. SPONSOR/MONITOR'S ACRONYM(S)	
				11. SPONSOR/MONITOR'S REPORT NUMBER(S)	
12. DISTRIBUTION/AVAILABILITY STATEMENT Approved for public release; distribution unlimited					
13. SUPPLEMENTARY NOTES					
14. ABSTRACT This report includes the calibration results of the Lab(k)-PTB TWSTFT link and closure measurements of the BIPM-Lab(k)- BIPM tour. During 10-20 Feb., 2015 (DOY 41-51, MJD 57063-57073), the BIPM Standard Travelling Calibration Station (StdB) visited Lab(k) in order to calibrate the Lab(k)-PTB TWSTFT link for UTC generation. This work follows the TWSTFT Calibration Guideline for UTC Time Links [1].					
15. SUBJECT TERMS					
16. SECURITY CLASSIFICATION OF:			17. LIMITATION OF ABSTRACT Same as Report (SAR)	18. NUMBER OF PAGES 11	19a. NAME OF RESPONSIBLE PERSON
a REPORT unclassified	b ABSTRACT unclassified	c THIS PAGE unclassified			

Content

Annex II. TWSTFT link calibration with a GPS calibrator	1
Notation.....	2
1 Summary	3
1.1 General.....	3
1.2 Summary of the main result	3
Table 1 The total delay correction for the TWSTFT time link Lab(k)-PTB	3
Figure 1 The time links on the UTC baseline Lab(k)-PTB during the calibration period.....	3
1.3 The Combined Uncertainty	4
2 Standard setups of the Std _B during a calibration tour	4
Figure 2 Setup of the BIPM Std _B at a UTC (<i>k</i>)	4
3 Setups at the Lab(<i>k</i>).....	5
Figure 3.1 Setup of the Std _B at the Lab(<i>k</i>) T/F laboratory	5
Figure 3.2 BIPM BP1C PPS IN/OUT measurements	5
Table 3.1 The receiver and antenna information.....	6
Table 3.2 The sub-delay information (in CGGTTS header etc.)/ns	6
4 Data reduction and analysis.....	6
4.1 GPSPPP solution.....	6
Figure 4.1.1a DCD of BP1C-BP0U, $A_v = 0.357 \pm 0.200$ ns.....	6
Figure 4.1.1b Tdev of the DCD in Figure 4.1.1a	7
4.3 The calibration of the TWSTFT link.....	7
Figure 4.1.2a DCD of TWSTFT and PPP (BP0U-PTBB) links of Lab(k)-PTB, $A_v = 1.484 \pm 0.309$ ns.....	8
Figure 4.1.2b DCD of TWSTFT and PPP (BP1C-PTBB) links of Lab(k)-PTB, $A_v = 1.770 \pm 0.339$ ns.....	8
4.2 The TWSTFT and GPSPPP links after the calibrations	9
Figure 4.2.1 DCD of Lab(k)-PTB link comparison. Both TW and PPP links are calibrated	9
5 Stability of Std _B and closure at BIPM before/after the Lab(<i>k</i>) tour	10
Table 5.1 The PPP closures at BIPM before and after the visits to Lab(<i>k</i>) vs. the GTR50 BP0T.....	10
References.....	10

Notation

UTC_p: the UTC(*k*) point at Lab(*k*). Here after the *k* stands for Lab(*k*), the laboratory to be calibrated

Link: a time link is a clock comparison result using a particular technique, e.g., a link of GPS C/A, P3, PPP or GLONASS or TWSTFT or TWOTFT. A UTC link at present is a time link between Lab(*k*) and PTB

Std_B: The GPS travelling calibrator. In this Lab(*k*) calibration tour, the BIPM standard traveling calibration station (calibrator) consisting of $N (\geq 2)$ GNSS receivers+antennas+cables and PPS/frequency-distributors. It is a pre-cabled black box calibrator with unknown but constant total delay during a calibration tour

Total Delay: The total electrical delay from the antenna phase center to the UTC_p including all the devices/cables that the satellite and clock signals pass through. It numerically equals the sum of all the sub-delays. The total delay uncertainty determines the UTC time transfer uncertainty

METODE²: MEasurement of TOveral DELay, the BIPM calibration system composed of related methods and equipment (Std_B) for the generation of UTC-UTC(*k*) in Circular T [1]

C_M: The METODE total delay correction. It should be *subtracted* from the GPS data, e.g. RefGPS-C_M in CGGTTS, -C_M in Clb_GNSS.Lst file; and *added* to the CALR of the ITU TWSTFT data of the Lab(*k*) side. Because the PTB is taken as the reference of the calibration, a GNSS time link correction is equal to the classic GNSS equipment calibration correction [8]

u_A, u_B: type A and type B uncertainties (1- σ)

u_M: Total uncertainty of the total delay correction C_M;

CCD: a difference of two system's data that have a common clock

DCD: double difference of two independent measurements of clock differences, for example via TWSTFT and GPS.

Tour: a calibration *tour* is a round trip calibration campaign with start and closure measurements. It may include several laboratories

² METODE was proposed in the frame of the BIPM pilot project (2011-2014) aiming at unifying the UTC time link calibration with an uncertainty ≤ 2 ns [2-4]. It is composed of a time link calibration scheme with the calibrator denoted Std_B.

This document describes a typical TWSTFT link calibration. If we replace the TWSTFT link by a GNSS link or a optical fiber (OF), it becomes a GNSS or an OF time link calibration. This calibration becomes a classic receiver calibration if the link includes the UTC network pivot (PTB), whose absolute calibration error is assumed to be zero. The calibration correction C_M can be converted to classical corrections of the Internal Delay, INTDLY(L1/L2), by removing the CABDLY and REFDLY. This introduces extra uncertainties. In consequence, the uncertainties of the INTDLY(L1/L2) maybe larger than 3 ns [3,15].

1 Summary

According to the TWSTFT guideline [1], a TWSTFT link calibration campaign is carried out using a mobile TWSTFT ground station or/and a GPS calibrator that are circulated among several time laboratories contributing to UTC. This report confines itself to the specific measurement of Lab(k)-PTB. A similar calibration tour of NIST-PTB has been made, the consistency of that report with previous TWSTFT calibrations of the Lab(k)-PTB and Lab(k)-NIST links will be presented elsewhere, as will be the issues involved with the application of these calibrations to the GPS receivers at the two sites.

1.1 General

This report includes the calibration results of the Lab(k)-PTB TWSTFT link and closure measurement of the BIPM-Lab(k)-BIPM tour with the BIPM standard travelling calibration station (Std_B). During 10-20 Feb., 2015 (DOY 41-51, MJD 57063-57073), the Std_B was installed at Lab(k), United States Naval Observatory, 3450 Massachusetts Ave, NW, Washington DC 20392 USA. The goal was to calibrate the Lab(k)-PTB TWSTFT link for UTC generation. This work and this report follow the TWSTFT Calibration Guideline for UTC Time Links [1].

As part of the BIPM Pilot Project, the METODE was developed to unify the UTC time link calibrations with a calibration uncertainty $u_B \leq 2$ ns [2-5]. Since 2013, the Std_B has visited the UTC labs OP, PTB, PL, AOS, TL, NMIJ, NICT, NIM (BSNC), and ROA [6]; experiments were made also at the BIPM, NIST and Lab(k) [7,8]. The two Std_B 's visits to PTB in June 2013 and Aug. 2014 [6] allow transferring the calibration of the PTB master receiver to the Lab(k). The difference of the two visits is 0.03 ns. This and the closure measurements at BIPM prove the long-term stability of the Std_B .

The requirements for the setup and computations can be found in the BIPM guideline [5]. Taking into account of the starting and closure measurements at the BIPM, we compute the calibration corrections for the UTC TWSTFT time links between Lab(k)-PTB. Since this link has been recently calibrated with TWSTFT, this supplies a supplementary and official GPS time link calibration.

GPSPPP solutions are used for this calibration, and hereafter the $UCT(k)$ or $Lab(k)$, refers only to $k=Lab(k)$.

1.2 Summary of the main result

Table 1 displays the calibration for the time link corrections (C_M) for the TWSTFT links on the baseline Lab(k)-PTB, see Table 1.

Table 1 The total delay correction for the TWSTFT time link Lab(k)-PTB

Lab	Time Rcv/Link	C_M/ns	u_M	ITU CI	S
Lab(k)	TWSTFT: Lab(k)-PTB	+0.9*	1.5 ns	888-2015	1

* In the files TWLABK57.070, and TWPTB57.070, we have the corresponding CALR=-488.0 ns for Lab(k) and +488.0 ns for PTB. The ESDVARs= are kept zero and unchanged, cf. Section 4.2.

Figure 1 shows the data of the related links. Of the available GPSPPP links, only USN6-PTBB is illustrated here. As shown in the plot, the Lab(k)-PTB TWSTFT and the GPSPPP links are close to each other but 0.9 ns and 1.5 ns lower than the Std_B -PTBB link.

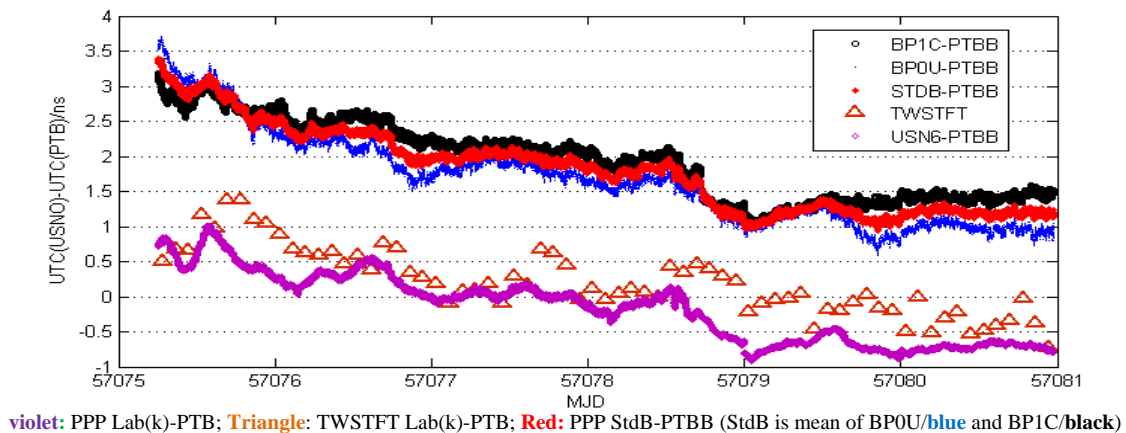

Figure 1 The time links on the UTC baseline Lab(k)-PTB during the calibration period

1.3 The Combined Uncertainty

The total uncertainty (U_M) of the C_i is composed of [3-4]:

- PPP Measurement uncertainty (u_A) of Std_B -UTC(k): 0.1~0.3 ns;
- PPP Measurement uncertainty (u_A) of UTC(k)-UTC(PTB): 0.1~0.3 ns
- TWSTFT Measurement uncertainty (u_A) of UTC(k)-UTC(PTB): 0.2~0.5
- Instability and the sub-delay measurement uncertainty of the reference at $Lab(k)$: 0.5~0.7 ns
- Instability of the traveling receivers: 0.5~1.0 ns;
- Others: 0.3~0.6 ns

The U_M as estimated from the root sum square (RSS) of the errors is hence (0.8~1.5) ns (1σ). However, the unknown random and systematic errors are likely to be higher than usual and therefore we take our uncertainty to be 1.5 ns.

If only one GPS receiver calibration component of the METODE is used, the instability would be factor of $\sqrt{2}$ higher, and $u_B = \sqrt{2} \times 1.5 \text{ ns} = 2.1 \text{ ns}$.

Other independent studies [6-15] prove that this calibration uncertainty of 1.5 ns or even below 1 ns [16] is attainable. Here each system can perform a calibration without sharing any common part with the other. It is best to have at least two receivers of different types. This may increase the measurement discrepancies but improves the uncertainty computation as well as the robustness of the calibration result.

2 Standard setups of the Std_B during a calibration tour

The setup of the Std_B is shown in the Figure 2 [5]. The cable C166 was directly connected to the UTC(t).

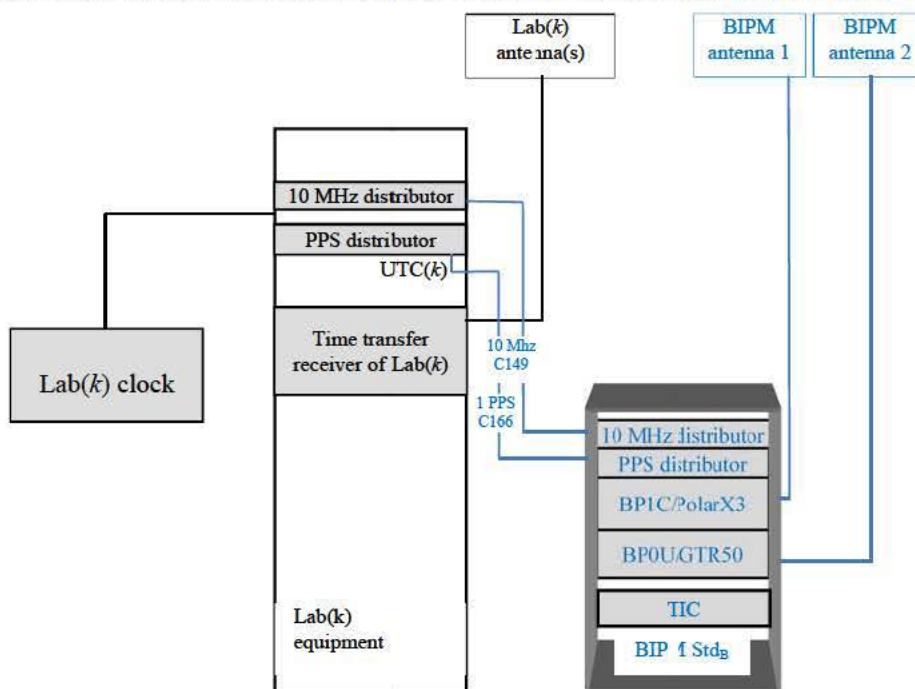

Figure 2 Setup of the BIPM Std_B at a UTC (k)

(The BIPM devices including cables are shown in blue. Lab(k)'s equipment are shown in black)

By the definition of the METODE UTC time line calibration correction [2,3], we have the following steps:

- We start from BIPM;
- We set the PTB's master GPS receiver (PTBB) as the reference of the calibration and its calibration correction to be zero;
- We align the Std_B to PTBB, i.e. the BP0U and BPIC in Std_B are to be corrected -5.2 ns and -3.6 ns [3];
- The Std_B goes to the Lab(k), and makes measurements side by side with the TWSTFT ground station of Lab(k). They use the same reference signals of UTC(k);
- We make the closure measurement at BIPM;

- We compute the double clock differences (DCDs) as shown in equation (1). Each data point is the result of the difference of a TWSTFT value and the interpolation of the 2 adjacent PPP values (computed every 5 min) or P3 values (computed about every 16 min). P3 technique is not the best option to carry out DCD, even worse for long baseline, nevertheless the differences with respect to PPP results are normally below 0,5 ns. The corresponding equation for the DCD is:

$$C_M = \text{DCD} = \text{Link(PPP)} - \text{Link(TW)} = [\text{UTC}_{\text{PPP}}(k)_{\text{Std}_B} - \text{UTC}_{\text{PPP}}(\text{PTB})] - [\text{UTC}(k) - \text{UTC}(\text{PTB})]_{\text{TW}} \quad (1)$$

here the GPSPPP data in the first bracket are taken while Std_B is at site k . The $\text{UTC}_{\text{TW}}(k)$ is measured by the TWSTFT equipment; The no-zero DCD is the calibration correction to the link $\text{Lab}(k)$ -PTB.

To average out the diurnal effects and measurement noise, 5-7 days of continuous measurements is required.

3 Setups at the Lab(k)

The setup and the 1-PPS IN/OUT measurements at Lab(k) are illustrated in the Figures 3.1 and 3.2. See also the photos on the cover page. The RefDly determination is critical, and is the only value that must be measured in both laboratories. Although not difficult in principle, subtle impedance matching issues, reflections, and even the choice of measurement technique could affect the measurement [2,15]. In the BIPM Std_B , a time interval counter (TIC) is shipped with to reduce the impact of the bias in the sub-delay measurements (Figure 2). In the setup of Figure 3.1, the RefDly of the Std_B is 66.2 ns.

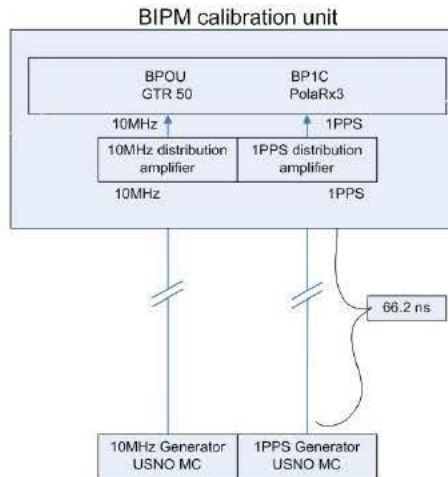

Figure 3.1 Setup of the Std_B at the Lab(k) T/F laboratory

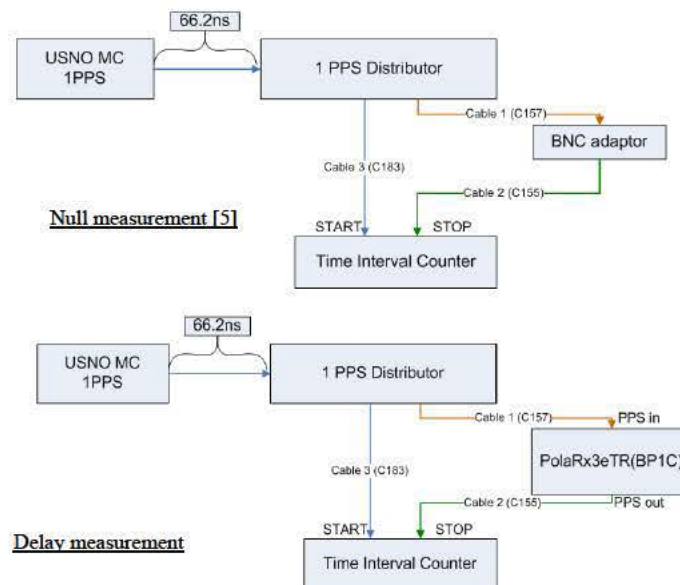

Figure 3.2 BIPM BP1C PPS IN/OUT measurements

Figure 3.2 shows the BIPM BP1C PPS IN/OUT measurement on 10/2/2015 before the calibration measurement started. On 20/2/2015, another measurement was made after the measurement. The difference was 0.05 ns and is negligible.

Table 3.1 is a summary of the receiver and the antenna information directly used in the calibration data processing. Table 3.2 lists the present sub-delays before the calibration. They will be used as the starting values for the calibration computations.

Table 3.1 The receiver and antenna information

No.	Receiver	Type	Antenna	Antenna code	Note
1	BP0U	GTR50	NOV702GG	NAE07190046	BIPM Std _B
2	BP1C	Sept. Polarx3	ASH701945E M	2000785	BIPM Std _B
3	PTBB	Ashtech Z12T	ASH700936E SNOW	CR15930	Master

#

Table 3.2 The sub-delay information (in CGGTTS header etc.)/ns

No.	Receiver	IntDly(L1)	IntDly(L2)	IntDly(L3)	CabDly	RefDly	Co*	C1*	C2*	C3*	TotalDly	Note
1	BP0U						-66.2	-20.8	5.2		-81.8	
2	BP1C						-66.2	225.2	3.6	-203.3	-6.5	before
3	PTBB	304.5	318.9	282.252	301.7	75.3					508.65	

* Co, C1, C2, C3 are the sub-delays/corrections. We use only the Total Delay for the link calibration

4 Data reduction and analysis

We use the equation (1) to compute the total delay calibration correction C_M through the DCD of the TWSTFT and the GPSPPP links.

4.1 GPSPPP solution

The RINEX files (including PTBB) were edited and corrected for cycle slips with the program Teqc before the PPP processing. For the Novatel receiver, the bias C1-P1 was taken into account using CC2nonCC.

Figures 4.1.1a and 4.1.1b show the DCD of the BP0U and BP1C and the TDev. The measurements were disturbed by unknown reasons. The DCD scatter up to 1 ns. Although most of the deviations should be averaged out, the possibility of a systematic bias in one of the two receivers cannot be ruled out by divided by 2. The mean value is 0.357 ± 0.200 ns.

The red triangles in the following figures are the day-averaged values.

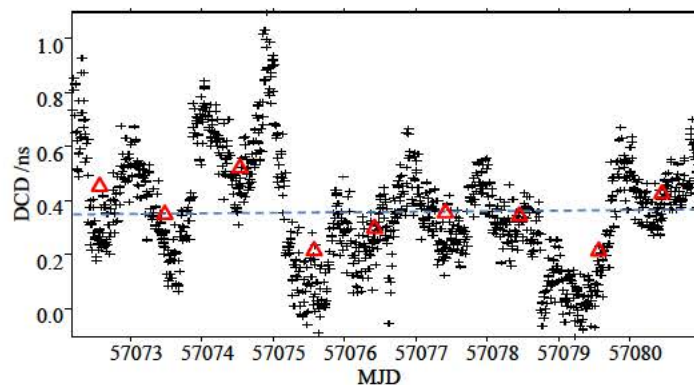

Figure 4.1.1a DCD of BP1C-BP0U, $A_v = 0.357 \pm 0.200$ ns

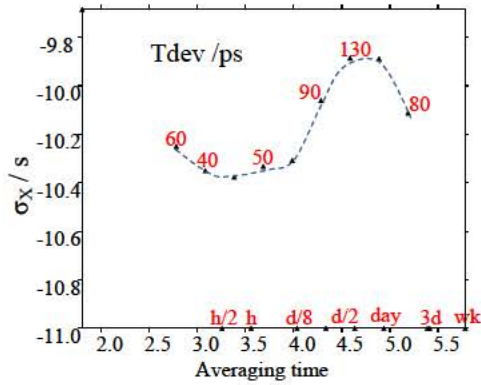
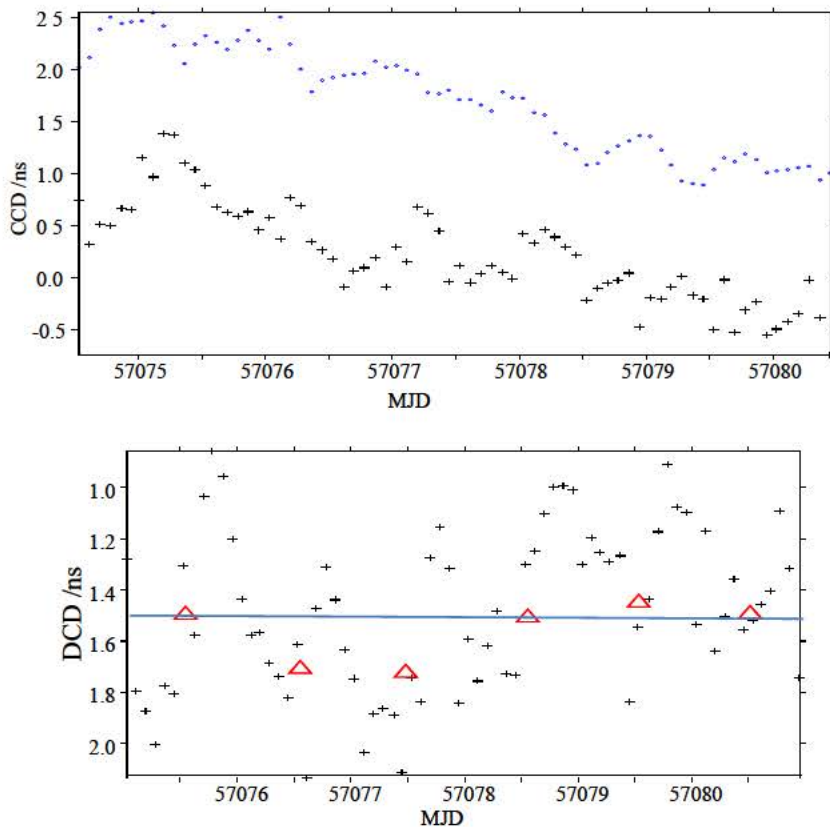

Figure 4.1.1b Tdev of the DCD in Figure 4.1.1a

4.3 The calibration of the TWSTFT link

The raw data of the GPS and TWSTFT between MJD 57075-57081 were used.

Figures 4.1.2a and 4.1.2b depict the CCD and DCD of the TWSTFT minus GPSPPP links over the baseline Lab(k)-PTB. Here and below, the black cross is TW link and blue circle the PPP link. The DCD, i.e., the calibration corrections, are 0.79 ns and 1.07 ns as measured by the BP0U and BP1C respectively. Their average TWSTFT link calibration correction is $C_M = 0.93$ ns with an uncertainty of 1.5 ns. If applied, it should be added to the CALR in the ITU file on the Lab(k) side and subtracted from the PTB ITU file..



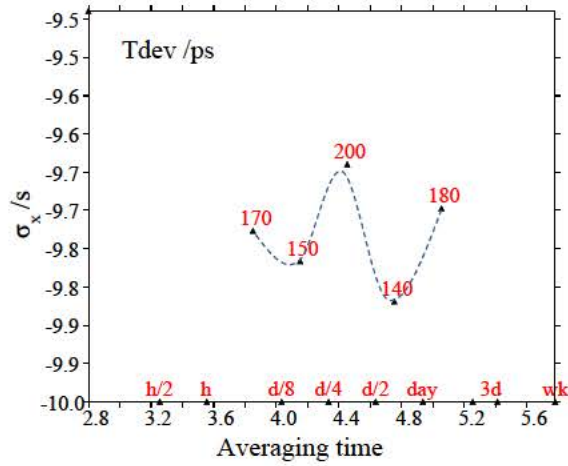

Figure 4.1.2a DCD of TWSTFT and PPP (*BP0U*-PTBB) links of Lab(k)-PTB, $A_v=0.79\pm 0.309$ ns

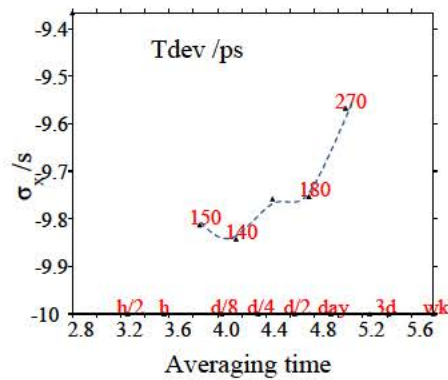
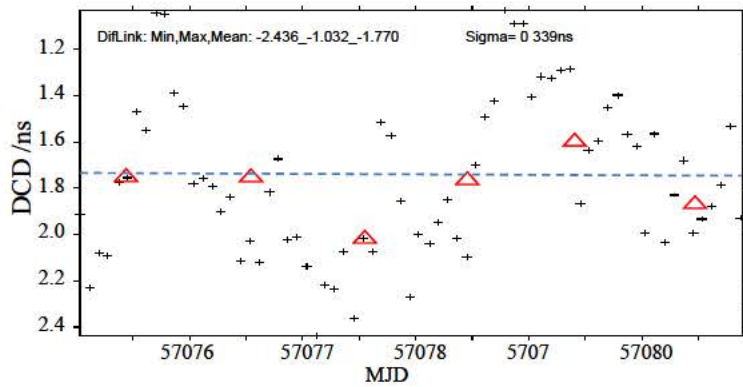
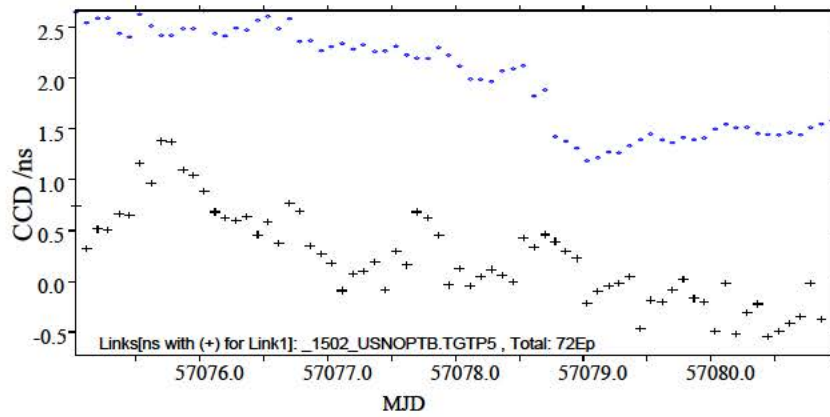

Figure 4.1.2b DCD of TWSTFT and PPP (*BP1C*-PTBB) links of Lab(k)-PTB, $A_v=1.07\pm 0.339$ ns

The present CALR= -488.884 ns with ESDVAR=0.000±0.0 ns in the ITU file TWLABK57.070. We have then

the METODEcalibrated CALR= $-488.88+(0.93)=-487.95$ ns with present ESDVAR=0 kept unchanged in both sides of PTB and Lab(k).

This correction should be *subtracted* from the ITU TWSTFT data format file of the PTB side but *added* to that of Lab(k) side. The Job of the BIPM Tsoft Menu Y20 for this calibration correction (active Calib) is:

```
Calib. _____ : S=0 CALR= 00000.000 ESDVAR= 00000.000 !CALR=-488.0=-488.9+0.9/ITU CI=394
Calib. PTB01 USNO01: S=0 CALR= +488.0 ESDVAR= 00000.000 !subtracted from ITU TWPTBmj.ddd
Calib. USNO01 PTB01: S=0 CALR= -488.0 ESDVAR= 00000.000 !added to ITU TWUSNOmj.ddd files
```

Note here that, usually the ESDVAR should be set to zero after calibration.

4.2 The TWSTFT and GPSPPP links after the calibrations

The calibration of the GNSS time transfer facility is not the goal of this calibration tour. We give the following GPSPPP and TWSTFT time link comparison result only as complementary information.

Figures 4.2.1a/b/c show the TWSTFT and USN6 GPSPPP links after that the new CALR(Labk)= -488.0 ns (ITU CI=394/ S=1) and the new INTDLY(L3) = +1.5 ns are applied, cf. Table 1 and [8]. The mean of the differences is 0.044 ns ± 0.284 ns. Diurnals in both GPSPPP and TWSTFT present as shown in the Figure 4.2.1a.

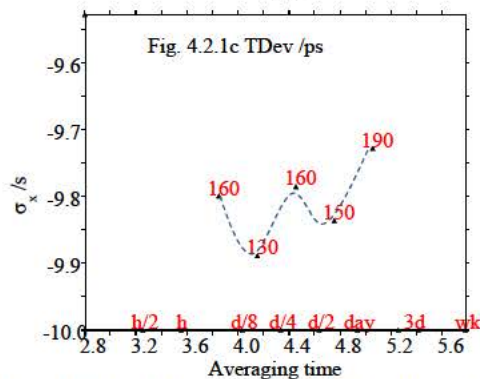
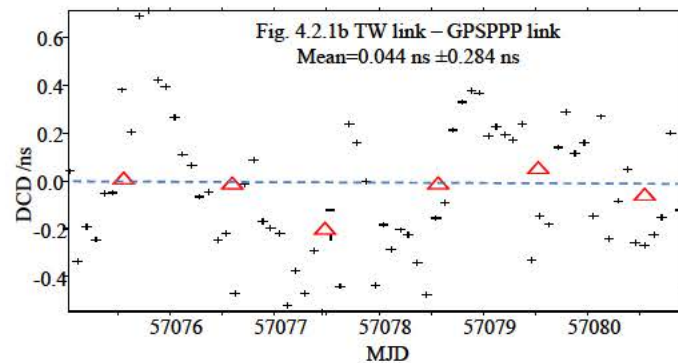
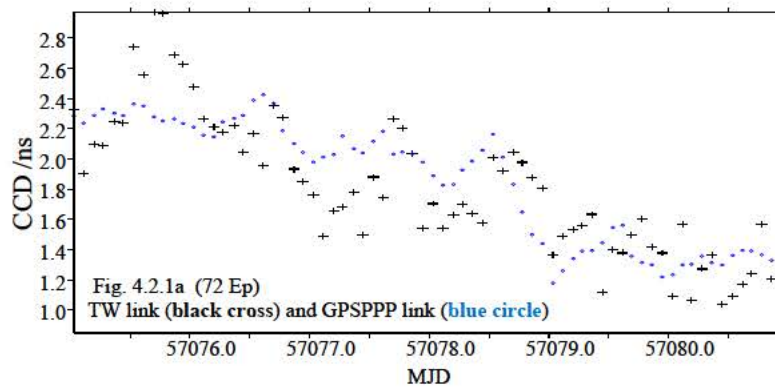

Figure 4.2.1 DCD of Lab(k)-PTB link comparison. Both TW and PPP links are calibrated

5 Stability of Std_B and closure at BIPM before/after the Lab(k) tour

The final computation should be made after the closure measurement which controls the stability of the Std_B. The Table 5.1 gives the GPSPPP closures at BIPM before and after the visit to Lab(k). The stationary BIPM receiver GTR50 BP0T is taken as a reference. On average, the closure of the Std_B is -0.2 ns for the two receivers and is negligible³. The two travelling receivers in the Std_B are separated each other of 0.4 ns. The Std_B is hence stable during the calibration tour.

The instability of the Std_B is no bigger than 0.5 ns since its last visit to PTB in Aug. 2014.

Table 5.1 The PPP closures at BIPM before and after the visits to Lab(k) vs. the GTR50 BP0T

Period	BPOU–BP0T/ns	BP1C–BP0T/ns	BP1C–BPOU/ns	Mean vs. BP0T/ns
57050-57056	-0.4±0.2	0.0±0.2	0.4±0.2	-0.2±0.2
57090-57096	-0.2±0.2	0.2±0.2	0.4±0.2	-0.0±0.2
Old-New closure	-0.2	-0.2	0.0	-0.2

Acknowledgements

The authors are grateful to the TWSTFT colleagues for their technical supports and close cooperation, in particular the participants of and the contributors to the BIPM Pilot Project on the UTC Time Links calibration [2] from BIPM, OP, PTB, PL, AOS, TL, NMIJ, NICT, NIM, BSNC, ROA, NIST and USNO.

References

- [1] CCTF WG on TWSTFT (2015) TWSTFT Calibration Guideline for UTC Time Links
- [2] Jiang Z., Arias F., Lewandowski W., Petit G. (2011) BIPM Calibration Scheme for UTC Time Links, Proc. EFTF 2011, pp 1064-1069
- [3] Jiang Z (2014) Accurate time link calibration for UTC time transfer, - Status of the BIPM pilot study on the UTC time link calibration, IN. Proc. EFTF2014
- [4] Jiang Z, Czubla A, Nawrocki J, Lewandowski W and Arias F (2015), “Comparing a GPS time link calibration to an optical fibre self-calibration with 200 ps accuracy”, *METROLOGIA* **52** 384 doi:10.1088/0026-1394/52/2/384
- [5] Tisserand L (2014) Notice for the BIPM calibration scheme METODE *MEasurement of TOTAal Delay* Draft 0.9 (06/06/2014)
- [6] Piester D., A; Bauch, H. Esteban, J Galindo, S. Y. Lin, W Wu, L Tisserand and Z Jiang (2014) BIPM TM235, METODE Experiments 2013-VIII, at and between BIPM, PTB and ROA Aug.-Sept. 2014
- [7] Patla B., S. Romisch, V. Zhang, Y. Lin, W Wu, L. Tisserand, G. Petit, F Arias and Z Jiang BIPM (2015) TM247, UTC link *calibration* report 2015-X, at NIST, Jan. 2015
- [8] Metchil S, Ed Power, J Hirschauer, D Matsakis, L Tisserand, W Wu, G. Petit, F. Arias and Z Jiang (2015) BIPM TM248, UTC link calibration report 2015-XI, at USNO, Feb. 2015
- [9] Piester D, Bumgarner R and McKinley A (2014) The June 2014 calibration of the link UTC(USNO) – UTC(PTB) by means of the USNO portable X-band TWSTFT station, presented to the 22nd CCTF Working Group on TWSTFT, VNIIFTRI, 15-16 Sept. 2014, Mendeleev, Russia
- [10] Galindo F J and Bauch A (2014) THE EUROPEAN TW CALIBRATION CAMPAIGN 2014 IN THE SCOPE OF GALILEO (TGVF-FOC), An opportunity to update, TW link calibrations in Europe, presented to the 22nd CCTF Working Group on TWSTFT, VNIIFTRI, 15-16 Sept. 2014, Mendeleev, Russia
- [11] Esteban H., J. Palacio, A. Bauch, D. Piester, G. Cerretto, T. Feldmann (2012) EURAMET Project 1156, GPSCALEU, Results of two years GPS receiver calibration campaign. Proc. 2012 European Frequency and Time Forum, 24-26 Apr 2012, Gothenburg, Sweden, pp. 354-360, 2012
- [12] Feldmann T., A. Bauch, D. Piester, P. Alvarez, D. Autiero, J. Serrano, G. Brunetti (2013) Relative Calibration of the Time Transfer Link between CERN and LNGS for Precise Neutrino Time of Flight Measurements. Proc. 44th Annual Precise Time and Time Interval (PTTI) Systems and Applications Meeting, Reston, Virginia, USA, pp. 141-150, 2013
- [13] Cerretto G., H. Esteban, M. Pallavicini, Va. Pettiti, C. Plantard, A. Razeto (2012) Measurement of CNGS Muon Neutrinos Speed with Borexino: INRIM and ROA Contribution. Proc. 44th Annual Precise Time and Time Interval (PTTI) Systems and Applications Meeting, Reston, Virginia, USA, pp. 133 - 140, 2012
- [14] Liang K. Feldmann T., Bauch A., Piester D.; Zhang A., Gao X. (2011) Summary of the Link Calibration between NIM and PTB Using a Traveling GPS Receiver, Proc. IFCS&EFTF2011
- [15] Lin Calvin S.Y., Huang Y. J., Tseng W. H. (2014) Upper Limit Uncertainty Estimation of TL METODE Calibration Tour Using Moving Cs Clock Method. Proc. ION PTTI 2014
- [16] Feldmann, T., Bauch, A, Piester, D., Rostt, M., (2011)m, “Advanced GPS Based Time Link Calibration with PTB’s new GPS Calibration Setup”, PTTI 2010

³ The Std_B has visited the PTB two times in June 2013 and in Aug. 2014. The difference is 0.03 ns [6].