

Image Cover Sheet

CLASSIFICATION

UNCLASSIFIED

SYSTEM NUMBER

510002



TITLE

STRESS ANALYSIS OF THE CANADIAN PATROL FRIGATE UNDER A HOGGING LOAD CASE USING
MAESTRO/DSA

System Number:

Patron Number:

Requester:

Notes:

DSIS Use only:

Deliver to:





National Defence
Research and
Development Branch

Défense nationale
Bureau de recherche
et développement

DREA CR/98/423

**STRESS ANALYSIS OF THE CANADIAN
PATROL FRIGATE UNDER A HOGGING
LOAD CASE USING MAESTRO/DSA**

D.R. Smith

Suite 707, 5959 Spring Garden Road
Halifax, Nova Scotia, Canada

CONTRACTOR REPORT

Prepared for

**Defence
Research
Establishment
Atlantic**



**Centre de
Recherches pour la
Défense
Atlantique**

Canada

THIS IS AN UNEDITED REPORT ON SCIENTIFIC OR TECHNICAL WORK
CONTRACTED BY THE DEFENCE RESEARCH ESTABLISHMENT ATLANTIC
OF THE RESEARCH AND DEVELOPMENT BRANCH OF THE DEPARTMENT
OF NATIONAL DEFENCE, CANADA.

THE CONTENTS OF THE REPORT ARE THE RESPONSIBILITY OF THE
CONTRACTOR, AND DO NOT NECESSARILY REFLECT THE OFFICIAL
POLICIES OF THE DEPARTMENT OF NATIONAL DEFENCE.

PLEASE DIRECT ENQUIRIES TO:

THE DIRECTOR GENERAL
DEFENCE RESEARCH ESTABLISHMENT ATLANTIC
P.O. BOX 1012
DARTMOUTH, NOVA SCOTIA, CANADA
B2Y 3Z7



National Defence
Research and
Development Branch

Défense nationale
Bureau de recherche
et développement

DREA CR/98/423

**STRESS ANALYSIS OF THE CANADIAN
PATROL FRIGATE UNDER A HOGGING
LOAD CASE USING MAESTRO/DSA**

D.R. Smith

Suite 707, 5959 Spring Garden Road
Halifax, Nova Scotia, Canada

Accepted by Layton Gilroy
Contract Scientific Authority

W7707-6-3561
Contract Number

May 1998

CONTRACTOR REPORT

**Defence
Research
Establishment
Atlantic**



**Centre de
Recherches pour la
Défense
Atlantique**

Canada

Abstract

This report describes a finite element stress analysis of the Canadian Patrol Frigate when it was subjected to a hogging load from an eight meter wave. The analysis was conducted using the program MAESTRO/DSA. Initially the analysis was performed on a global MAESTRO model of the entire ship and a region of high stress was identified. The region was refined using the DSA (Detail Stress Analysis) portion of the program and a top-down analysis was carried out by applying the displacements from the MAESTRO analysis. They were applied to the corresponding nodes of the refined portion of the MAESTRO model and detail stresses were obtained which were found to be higher than those obtained from the global MAESTRO analysis. A second refinement of the high stress region was carried out which covered a larger portion of the structure. The model was created externally using the program HYPERMESH. This larger refined portion was also subjected to a top-down analysis and stresses were obtained. The results of the three analyses are compared.

Résumé

Le présent rapport décrit une analyse de contraintes par éléments finis de la frégate canadienne de patrouille soumise à une charge d'arc par une mer de huit mètres. L'analyse a été effectuée en utilisant le programme MAESTRO/DSA. Elle a été effectuée initialement sur un modèle MAESTRO du navire au complet, ce qui a permis d'identifier une région de contraintes élevées. La région a été affinée à l'aide de la partie DSA du programme et on a effectué une analyse descendante en appliquant les déplacements à partir de l'analyse MAESTRO. Ils ont été appliqués par les noeuds correspondants de la partie affinée du modèle MAESTRO et on a obtenu des contraintes qui se sont avérées supérieures à celles obtenues par l'analyse MAESTRO. On a effectué un deuxième affinage de la région des contraintes élevées, mais il couvrait une portion plus grande du modèle et a été effectué extérieurement par le programme HYPERMESH. Cette partie affinée plus grande a aussi été soumise à une analyse descendante et on a obtenu des contraintes. Les résultats de ces analyses sont comparés.

Contents

Abstract	ii
Table of Contents	iii
List of Tables	iv
List of Figures	v
1 Introduction	1
2 MAESTRO Model of the Ship	1
2.1 Model Loading	2
2.2 Model Boundary Conditions	2
3 Results of the MAESTRO Analysis	2
4 Refined Model of the High Stress Region	2
5 Results of the Top-down Analysis with the Refined Model	3
6 Externally Generated Refined Model of the High Stress Region	3
7 Results of the Top-down Analysis with the Externally Generated Model	3
8 A Comparison of the Results of the Three Analyses	4
9 Conclusions	4
References	33

List of Tables

1	Comparison of the Highest Stresses from the MAESTRO, the Refined, and the Externally Generated Model Analyses	4
---	-------------------------------------------------------------------------------------------------------------------------	---

List of Figures

1	The MAESTRO Model of the Ship	5
2	A Schematic of the MAESTRO Model Showing the Substructures and the Modules	6
3	Midship Module Cross-section Showing the Location of the Strakes and Nodes	7
4	The Longitudinal Load Distribution	8
5	The Transverse Load Distribution	9
6	The Boundary Conditions Applied to the MAESTRO Model	10
7	The Deflected Shape of the MAESTRO Model	11
8	The The Von Mises Element Stresses in the Main Deck and Superstructure	12
9	An Enlarged View of the High Stress Region with the Aft Superstructure Removed	13
10	A Crossection View Looking Forward from Frame 28.5 at the High Stress Region	14
11	A Cross-section View Looking Aft from Frame 28.5 at the High Stress Region	15
12	MAESTRO Elements that were Replaced by the Regular Elements of the Refined Portion of the Model	16
13	The Refined Portion of the Model	17
14	The Refined Portion Merged with the MAESTRO Model	18
15	The Boundary Conditions Applied to the Refined Portion of the Model	19
16	The Distortion of the Refined Portion of the Model Due to the Loading	20
17	The Von Mises Element Stresses in the Refined Portion of the Model	21
18	The Maestro Elements Replaced by the Externally Generated Model	22
19	The MAESTRO Model with the Elements Removed	23
20	The Externally Generated Model	24
21	The Externally Generated Model Merged with the Maestro Model	25
22	The Boundary Conditions Applied to the Externally Generated Model	26
23	Distortion of the Model due to a Hogging Load	27
24	A Fringe Plot of the Displacements of the Externally Generated Model	28
25	A Fringe Plot of the Displacements of the MAESTRO Model	29
26	Von Mises Stresses in the Externally Generated Model	30
27	An Enlarged View of the High Stress in the Aft Deckhouse	31
28	An Enlarged View of the High Stress in the Forward Deckhouse	32

1 Introduction

A stress analysis of the Halifax Class Frigate was carried out to determine the region of highest stress in the main deck and superstructure when the ship was subjected to a static wave-induced hogging load condition. The structural model was a finite element model of the entire ship created in the format of the structural analysis program MAESTRO[1]. It was subjected to a MAESTRO analysis and the region of highest stress was identified. The region was locally refined using MAESTRO/DSA[2] which is a detailed stress analysis program using VAST[3] merged with MAESTRO. The procedure was that of a top-down analysis whereby the results of the MAESTRO analysis were applied to coincident nodes of the refined and MAESTRO models in the form of prescribed displacements. The additional nodes generated by the refinement were slaved to the coincident nodes, now master nodes, to assist in reducing the incompatibility at the boundaries.

A second refinement of the high stress region was carried out. The refinement was over a much larger area which included longitudinal and transverse bulkheads. The model was generated external to MAESTRO/DSA and then merged with the MAESTRO model using MAESTRO/DSA to locate the master nodes at the boundaries. The model was then subjected to a top-down analysis in the same manner to obtain the stresses in the refined portion.

The results of the three analyses are compared as an assessment of the degree of refinements required to obtain a good representation of the stress condition in a region of high localized stress.

2 MAESTRO Model of the Ship

The MAESTRO model of the ship is shown in Figure 1. The model was divided into three MAESTRO substructures as illustrated in Figure 2. The first was from the stem to frame 34, and the second was the length from frame 34 to the stern. The third substructure was the superstructure. Each of the substructures was divided into modules. There were six modules in substructures one and two, and five in substructure three. Each module was used to model a portion of the ship structure which maintained approximately the same cross-section shape. The modules increased or decreased linearly in overall size over their length. In this way modules were used to define geometry as well as specific components such as superstructure.

The modules were divided into strakes. The strakes stretched from one end of a module to the other. They made up the module cross-section as shown in the midship cross-section in Figure 3. The strakes were of uniform plate thickness and, as in this case, had uniformly spaced identical longitudinal stiffeners smeared into the strake cross-section to give an equivalent cross-section area. The strakes resisted in-plane loads but not lateral loads which cause bending. Girders in the structure were defined as beams running along the edge of the strakes and they provided axial and bending stiffness to resist in-plane and lateral loads.

The strakes were divided along their length by uniformly spaced transverse frames. Longitudinal frame divisions are called sections in which the frames are modelled as beam elements resisting both axial and lateral loads. The frame cross-sections were constant over the width of a strake but were varied as required from strake to strake. The co-ordinate system for the model was a right handed system with the X axis as the longitudinal axis of the ship and placing zero

at the forward perpendicular. The Y axis was the vertical axis with zero at the keel. The Z axis was positive to port.

2.1 Model Loading

The load case applied to the MAESTRO model was an 8 metre wave static balance for a hogging response which included a 15-tonne design change margin, appendage buoyancy, the weight curve with 80-tonne design and construction margin, and a hog horizontal acceleration correction. This data was translated into concentrated loads and applied to the MAESTRO element nodes at the frame and strake edge intersections. The weight was defined at each section interval where it was distributed uniformly over the corresponding cross-section. The longitudinal distribution of the loading is shown in Figure 4. The large vectors near the stern represent the buoyancy of the propeller shafting and the propellers. The transverse load distribution is shown in Figure 5. The static wave balance was obtained by the use of the program TRIM[4].

2.2 Model Boundary Conditions

The boundary conditions applied to the MAESTRO model were located to obtain a positive definite system with as little reaction force as possible due to the static wave balance load. The boundary conditions are shown located in a wire drawing of the model in Figure 6.

3 Results of the MAESTRO Analysis

The deflected shape resulting from the loading is shown in Figure 7. It is typical for the loading case as it indicates hogging. The Von Mises element stresses in the main deck and superstructure are shown in Figure 8. A high stress of 150 MPa is indicated in the region between frames 28 and 29 in the deck adjacent to the diesel intake deck house. An enlarged view, with the deck house aft of frame 29 removed, is shown in Figure 9 for a better appreciation of the stress distribution in the region. A cross-section through the model looking forward from frame 28.5 is shown in Figure 10 to illustrate the stress condition in the interior. A similar view looking aft is shown in Figure 11.

4 Refined Model of the High Stress Region

The refined model of the high stressed region was created using the detailed stress analysis modelling capability of MAESTRO/DSA. The MAESTRO beams and strake panels were refined and replaced with regular VAST elements. The MAESTRO elements that were replaced are shown in Figure 12. The refined portion of the model is shown separately in Figure 13 and merged with the MAESTRO model in Figure 14. The quadrilateral elements are yellow and the triangular elements are red. The boundary conditions applied to the refined model nodes, coincident with the MAESTRO nodes, and nodes slaved to them at the MAESTRO and refined model interface, are shown in Figure 15. In accordance with top-down procedure, displacements obtained from the previous MAESTRO hogging load analysis were applied to

coincident boundary nodes at the interface and a finite element analysis of the refined model was performed.

5 Results of the Top-down Analysis with the Refined Model

The finite element program VAST, which forms part of the DSA component of MAESTRO/DSA, was used to obtain the results of the analysis. The distortion of the refined model due to the loading is shown in Figure 16. The element stresses obtained are shown in Figure 17. The highest Von Mises stress increased to 274 MPa and moved to the side of the forward deckhouse at frame 28 and to the deck at frame 29.

6 Externally Generated Refined Model of the High Stress Region

The second and larger and more structurally accurate refined model of the high stress region, extending from frame 26 to frame 34, was created outside MAESTRO using the mesh generating program HYPERMESH[5]. Regular plate and beam elements from the VAST library of elements were used for the model. The MAESTRO elements replaced by the externally generated model are shown in Figure 18. The MAESTRO model with the elements removed can be seen in Figure 19. The refined portion is shown separately in Figure 20. Because it was created using the ship drawings rather than the global MAESTRO model, details not modelled in the MAESTRO model, such as the hatches on the port and starboard of the forward deckhouse were included. The model is shown merged with the MAESTRO model in Figure 21.

As in the case of the refined model, boundary conditions were applied at the boundaries at the master and slave nodes as shown in Figure 22. Displacements obtained from the MAESTRO hogging analysis were automatically applied to the coincident boundary nodes at the interface between the MAESTRO model and externally generated model. A finite element analysis was then performed using VAST.

7 Results of the Top-down Analysis with the Externally Generated Model

The distortion of the merged MAESTRO and externally generated model, from the hogging load analysis, is shown in Figure 23. A fringe plot of the displacements in the externally generated model is shown in Figure 24. For comparison, the displacements obtained from the MAESTRO analysis can be seen in Figure 25.

The resulting von Mises element stresses are shown in Figure 26. Enlarged views of the high stresses in the aft deckhouse are shown Figure 27 and in the forward deckhouse in Figure 28.

8 A Comparison of the Results of the Three Analyses

The displacements from the MAESTRO analysis are in good agreement with those from the top-down analysis with the externally generated model. The highest Von Mises stress obtained from the MAESTRO analysis was 150 MPa. It was located in the deck between the two deckhouses. When the structure in the high stress region was refined, the highest stress increased to 274 MPa and moved to the side of the forward deckhouse at approximately frame 28 and to the deck at frame 29.

The more structurally accurate externally generated model showed a Von Mises stress increase to 352 MPa in the side of the aft deckhouse and to 327 MPa in the coaming of the hatch in the forward deckhouse. A summary of the highest stresses is given in Table 1.

Table 1: Comparison of the Highest Stresses from the MAESTRO, the Refined, and the Externally Generated Model Analyses

Analysis	Model	Von Mises Stresses (MPa)
MAESTRO	MAESTRO Model	150 in plate
Top-down	Refined Model	274 in plate
Top-down	Externally Generated Model	352 in plate

9 Conclusions

The stresses obtained from the MAESTRO analysis were shown to be much lower than those obtained when the high stress region was refined using MAESTRO/DSA. The more detailed externally generated model showed even higher stresses and indicated new high stress locations in the side of the aft deckhouse and in the coaming around the hatch opening of the forward deckhouse. The results show that it is important to investigate regions of high localized stress, found by a MAESTRO analysis, with a method such as top-down analysis. This allows reasonably good boundary conditions, obtained from the MAESTRO analysis, to be applied to a refined model of the high stress region.

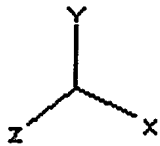
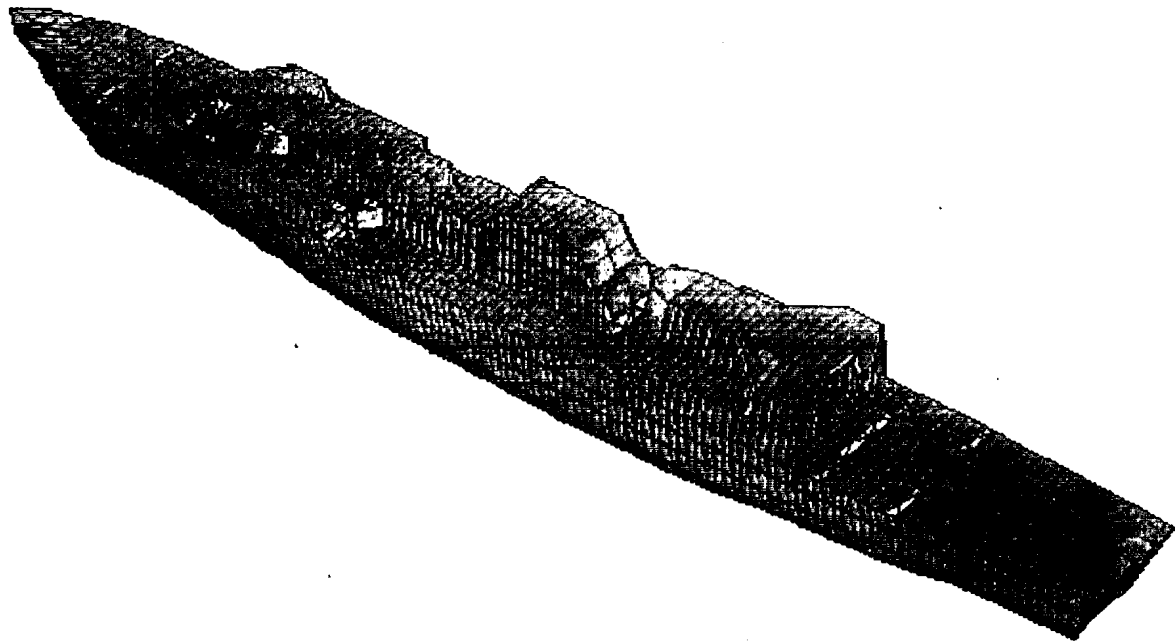

Figure 1: The MAESTRO Model of the Ship

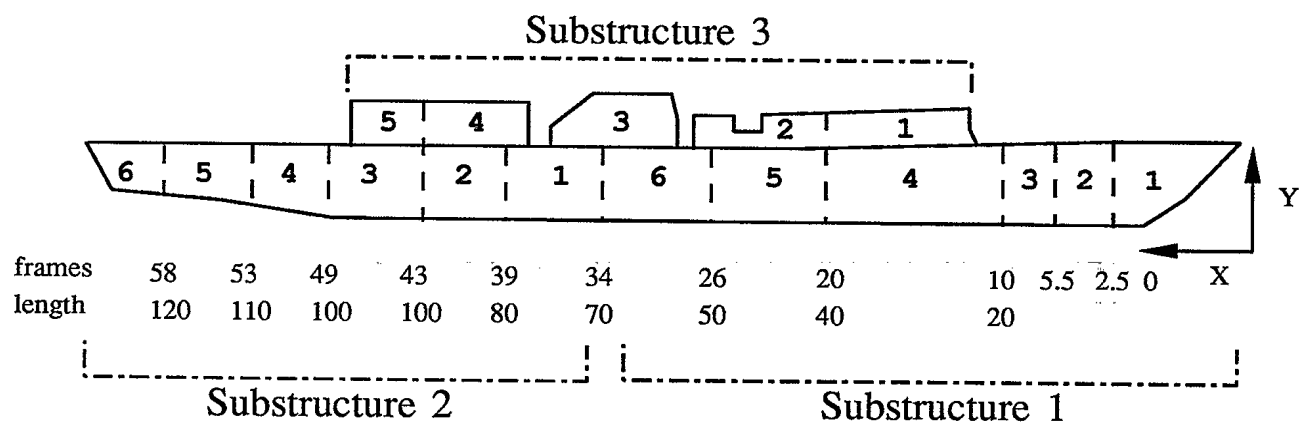

Figure 2: A Schematic of the MAESTRO Model Showing the Substructures and the Modules

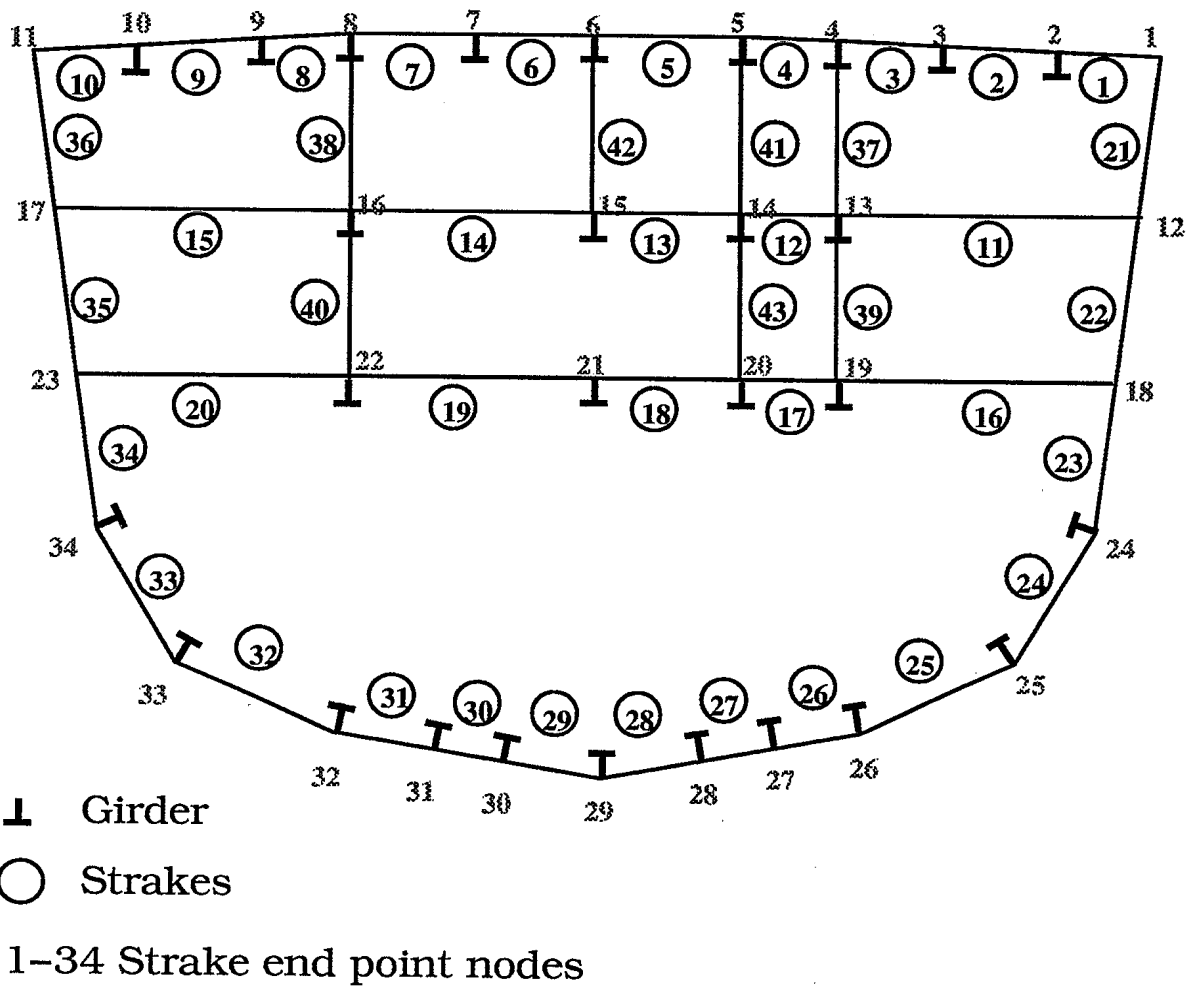

Figure 3: Midship Module Cross-section Showing the Location of the Strakes and Nodes

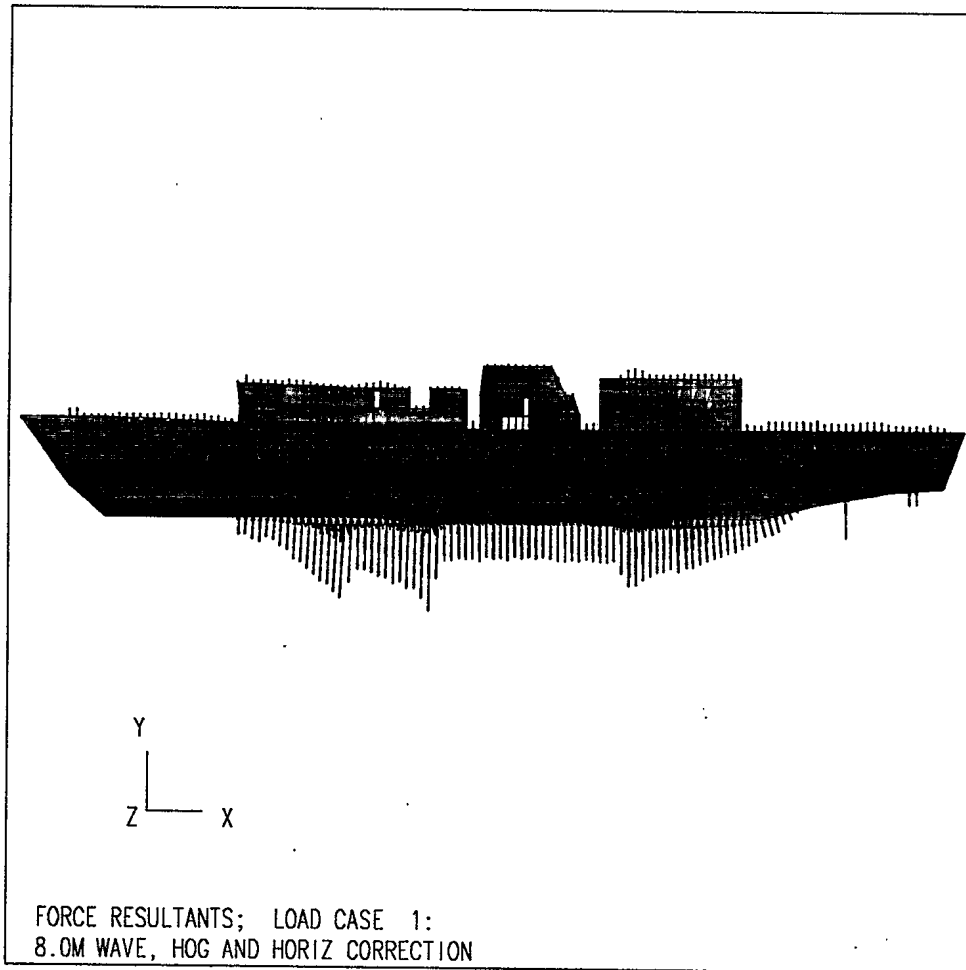

Figure 4: The Longitudinal Load Distribution

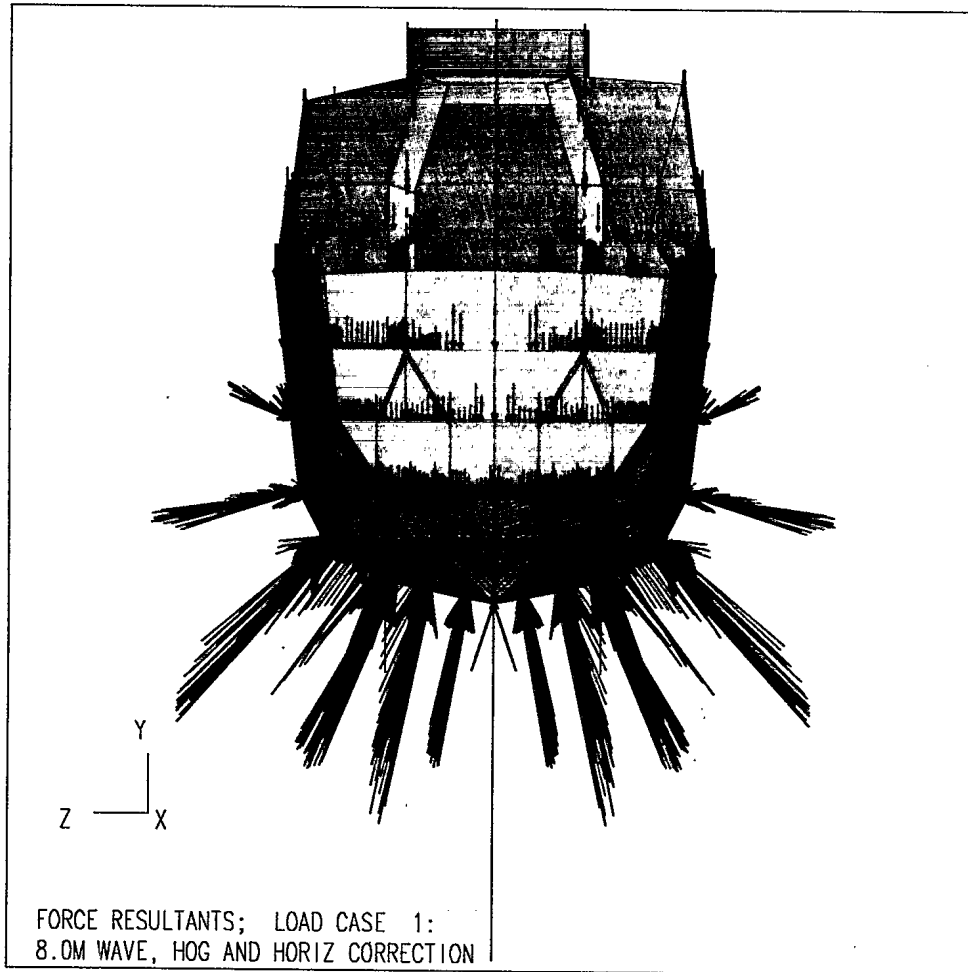

Figure 5: The Transverse Load Distribution

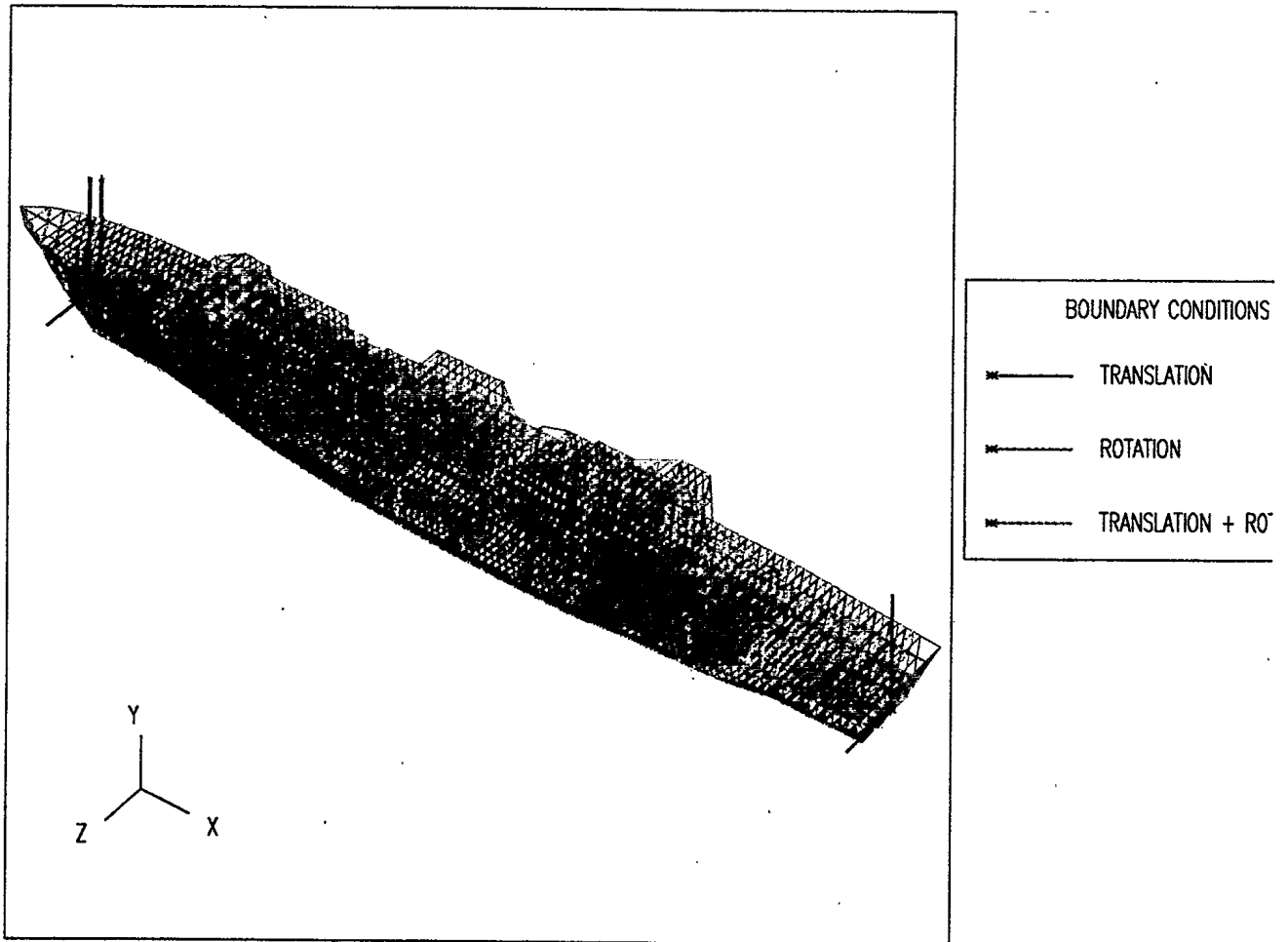

Figure 6: The Boundary Conditions Applied to the Maestro Model

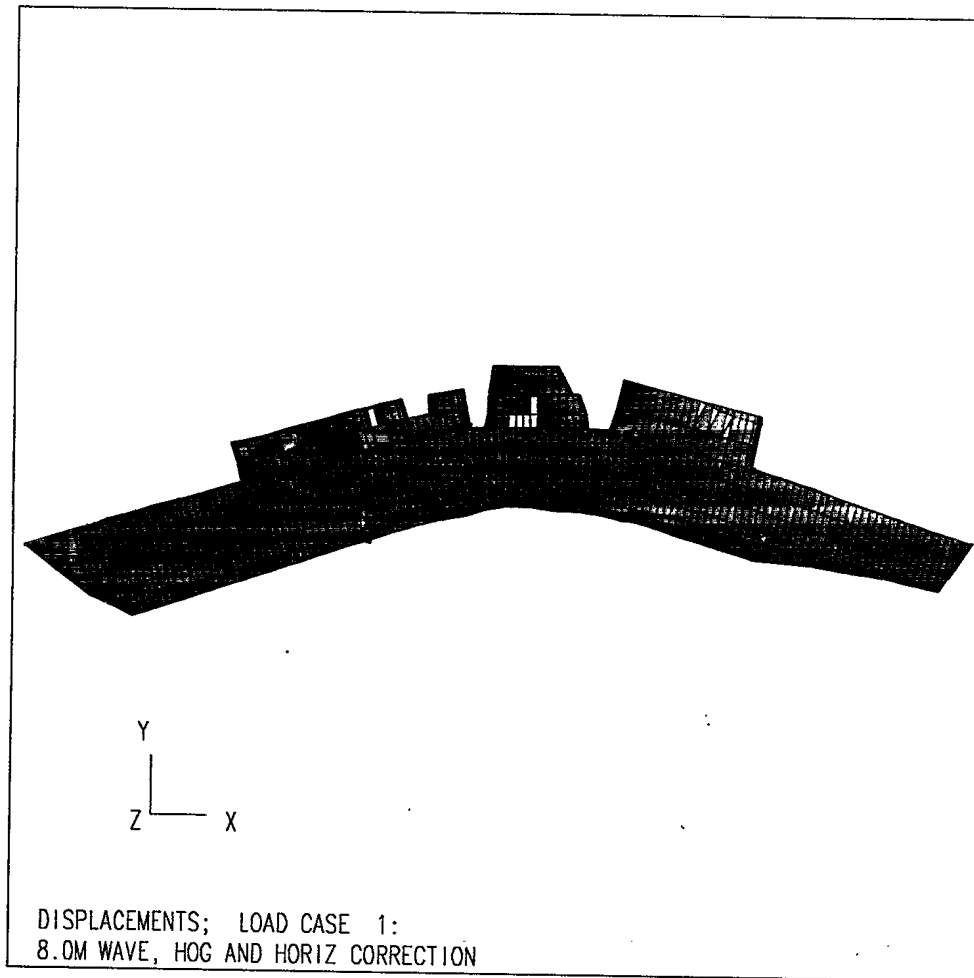

Figure 7: The Deflected Shape of the Maestro Model

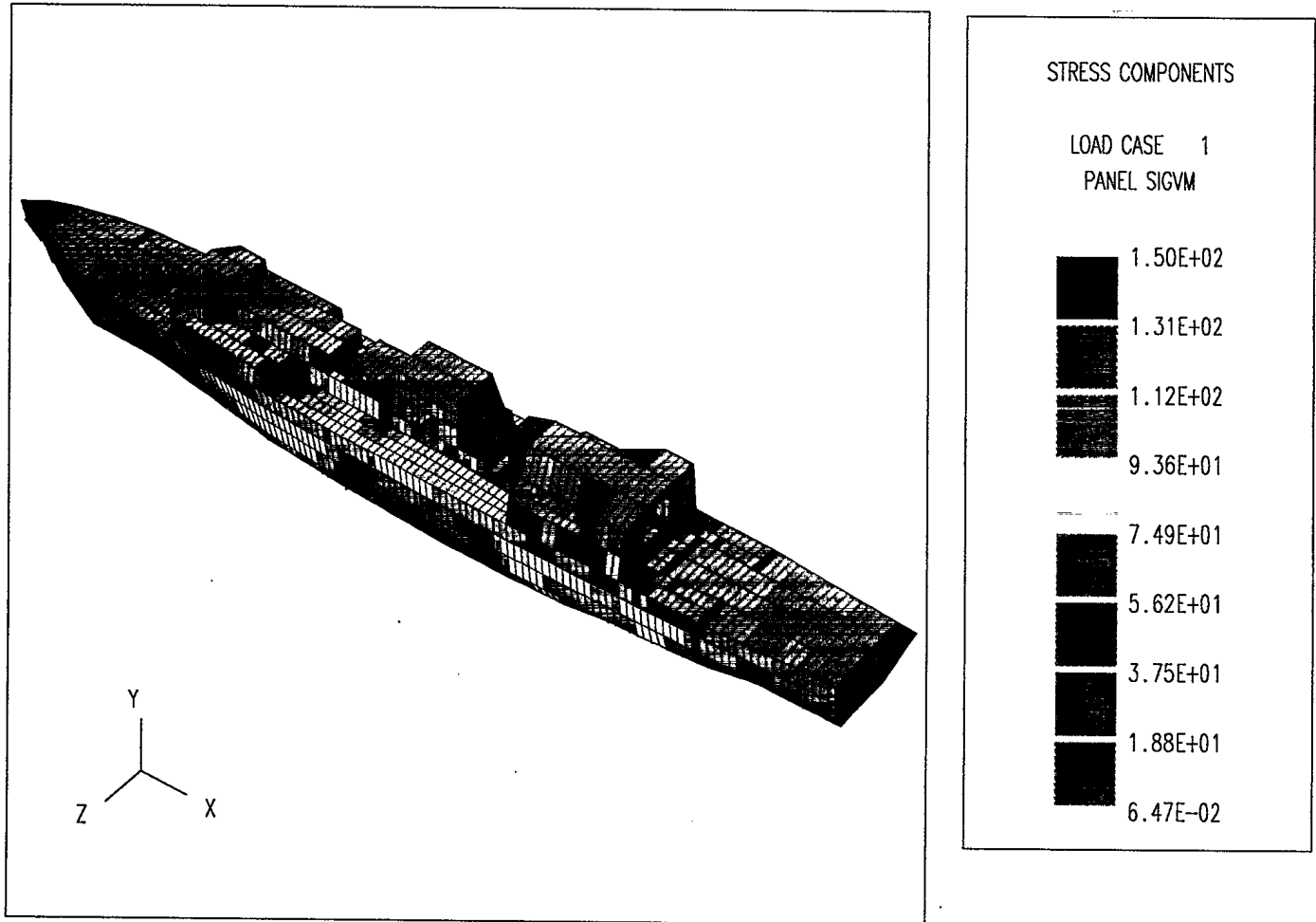

Figure 8: The Von Mises Element Stresses in the Main Deck and Superstructure

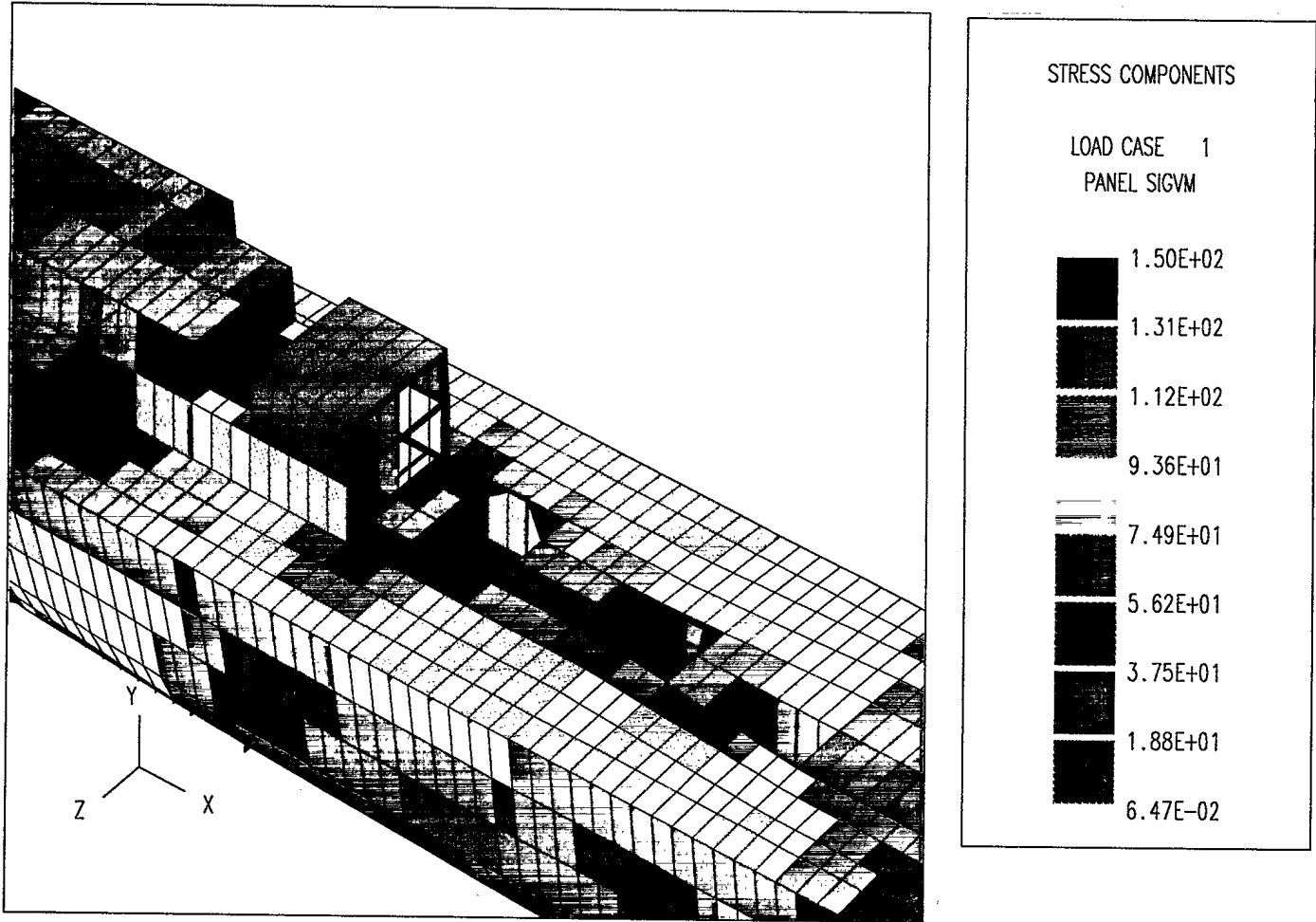

Figure 9: An Enlarged View of the High Stress Region with the Aft Structure Removed

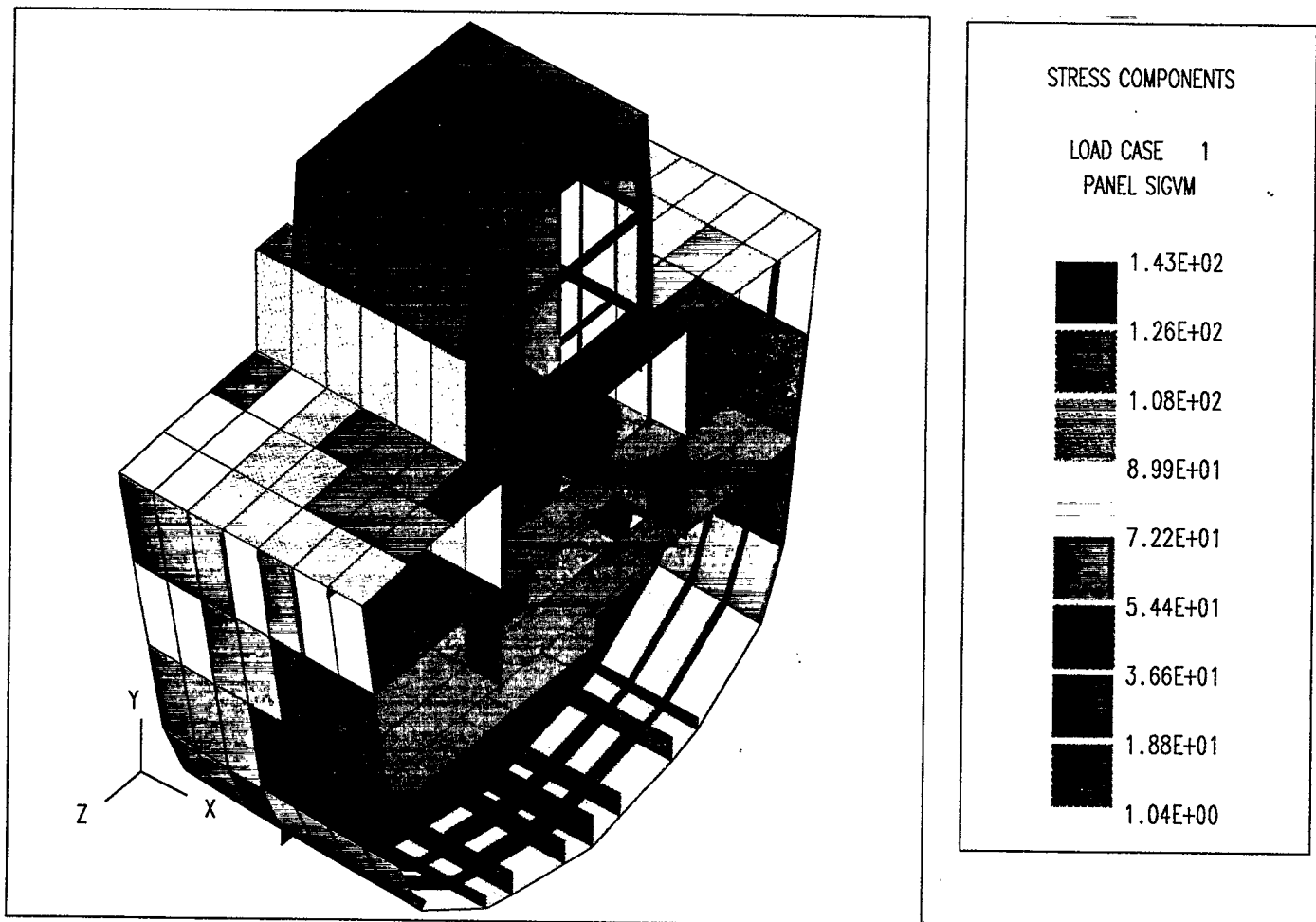

Figure 10: A Cross-section View Looking Forward from Frame 28.5 at the High Stress Region

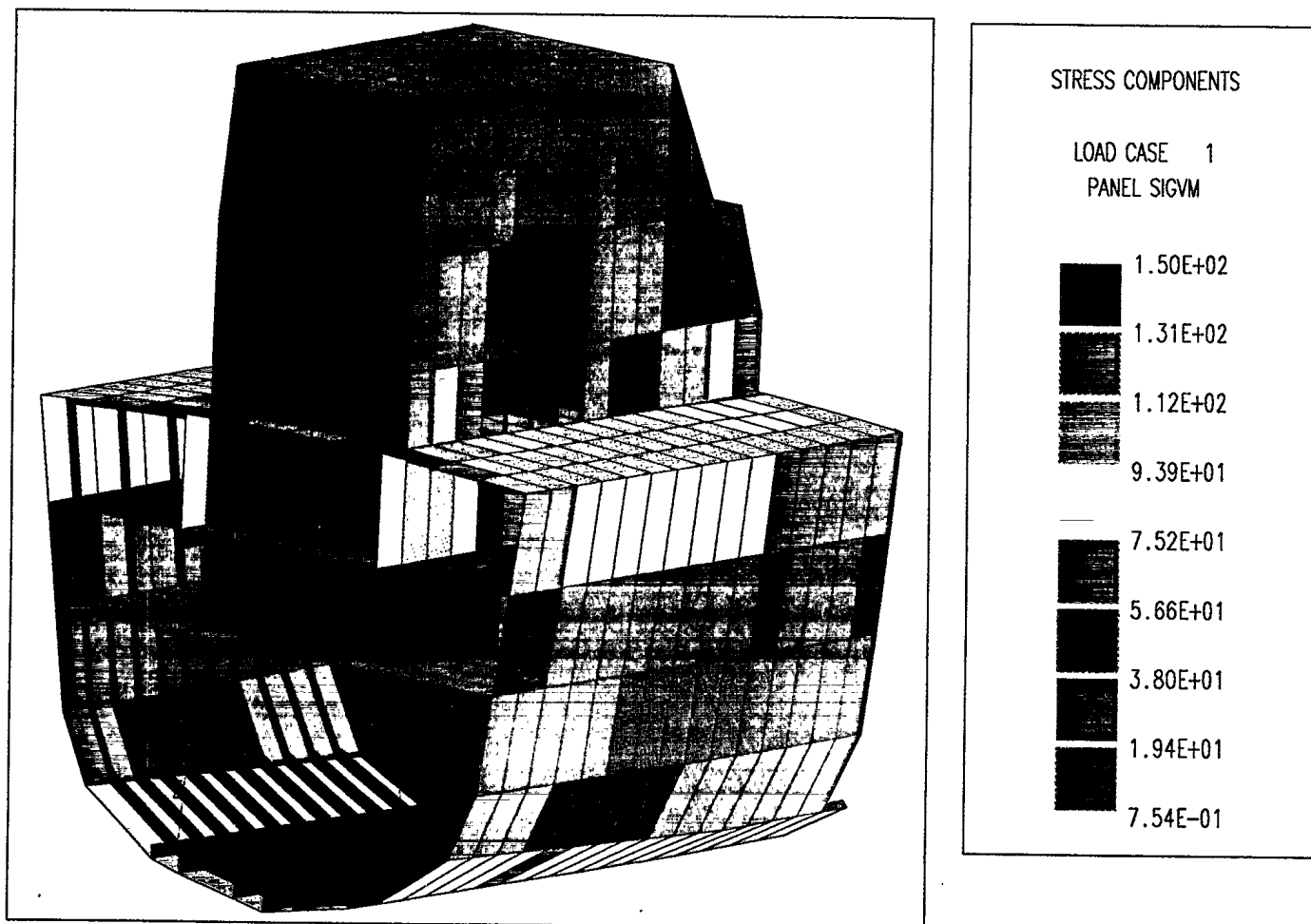

Figure 11: A Cross-section View Looking Aft from Frame 28.5 at the High Stress Region

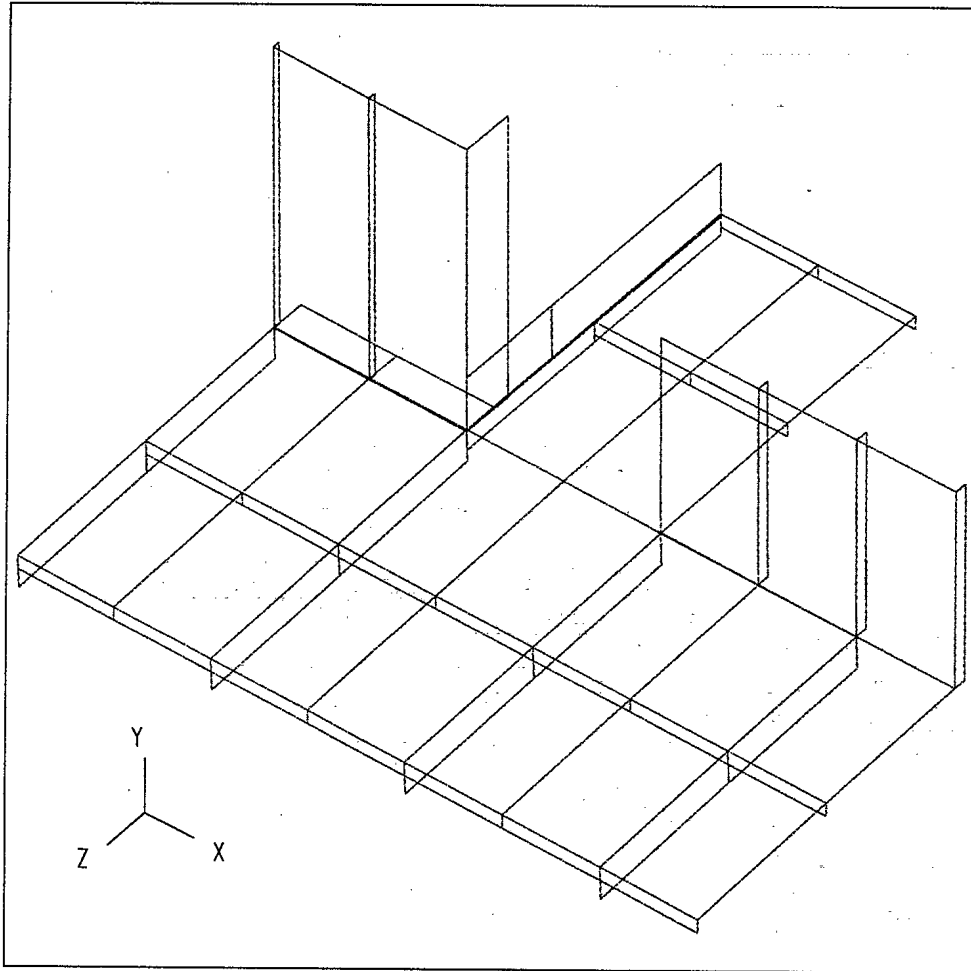

Figure 12: Maestro Elements that were Replaced by the regular Elements of the Refined Portion of the Model

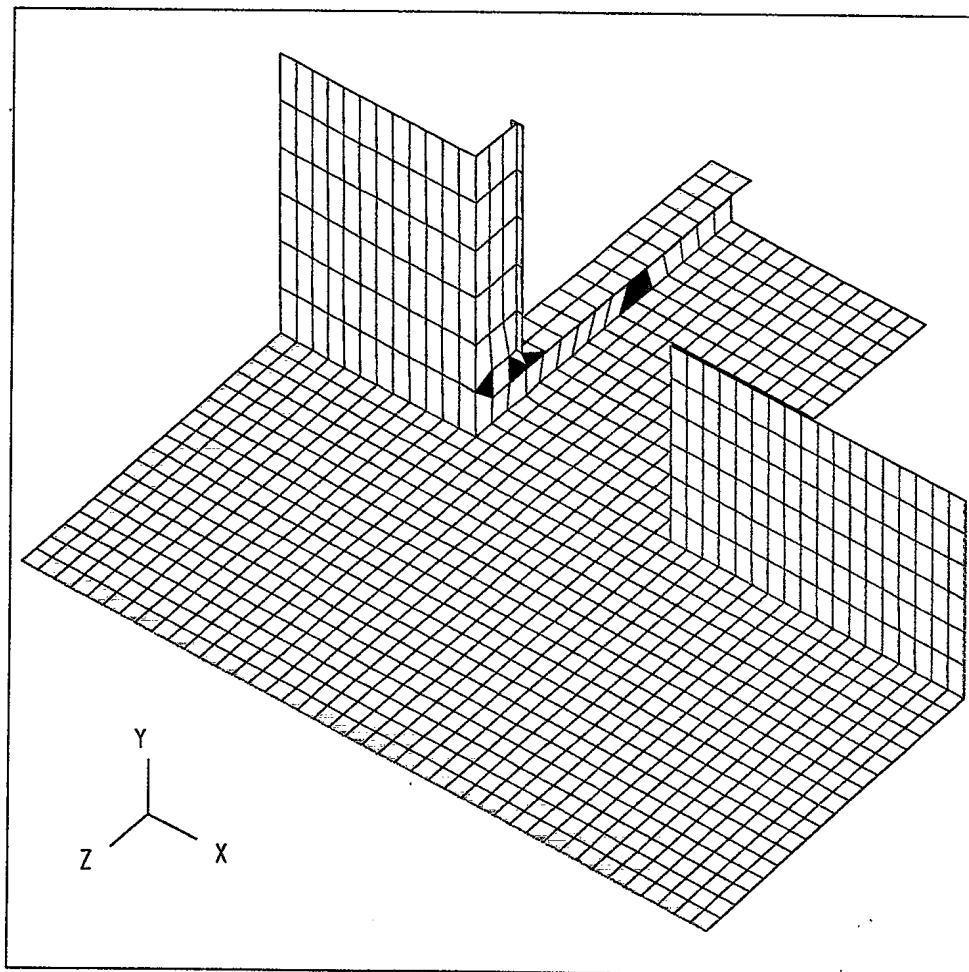

Figure 13: The Refined Portion of the Model

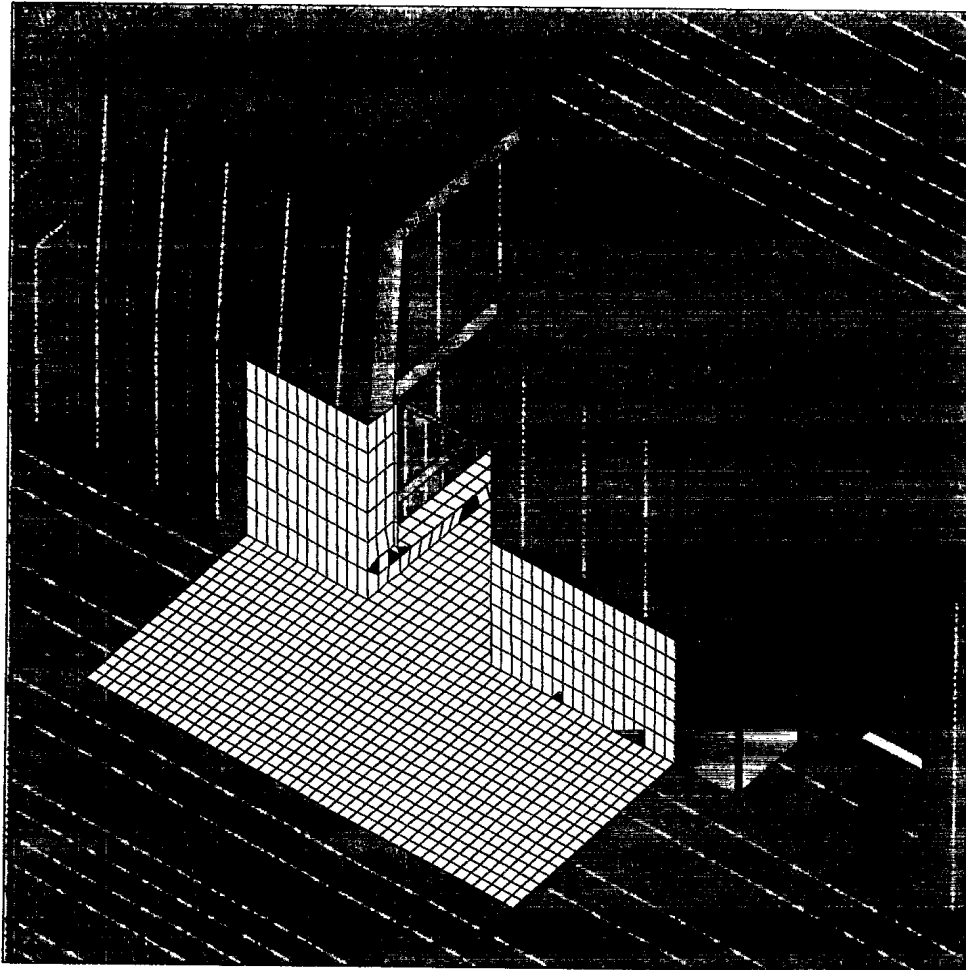

Figure 14: The Refined Portion Merged with the Maestro Model

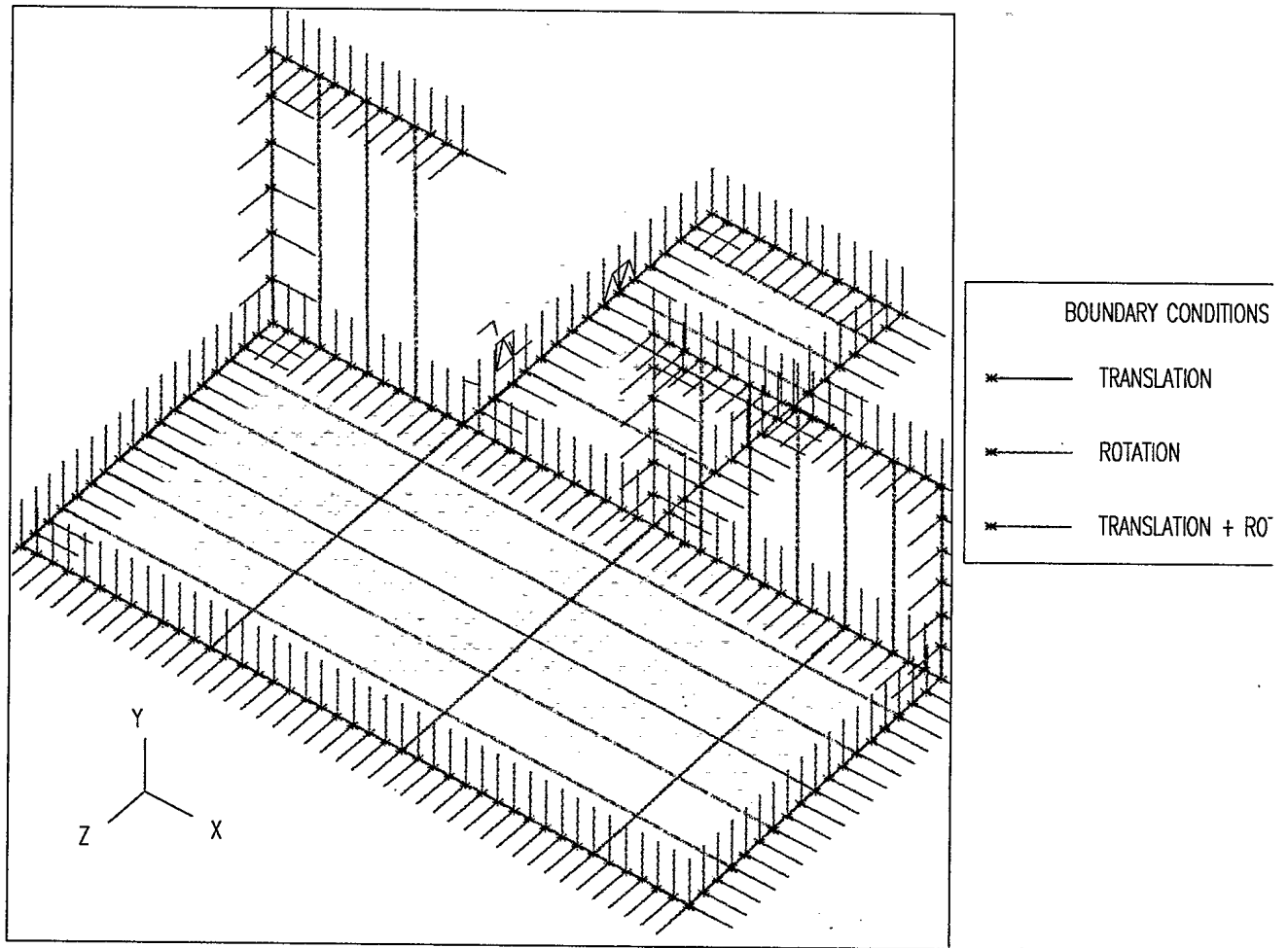

Figure 15: The Boundary Conditions Applied to the Refined Portion of the Model

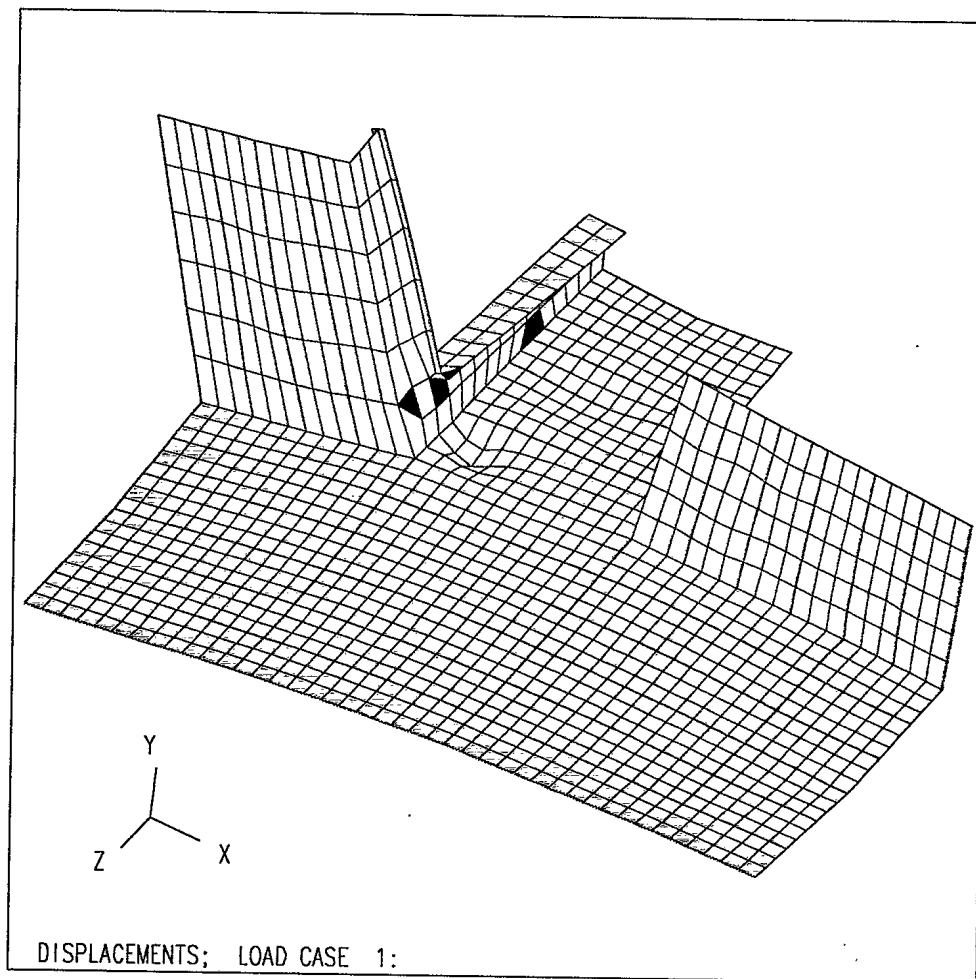

Figure 16: The Distortion of the Refined Portion of the Model due to the Loading

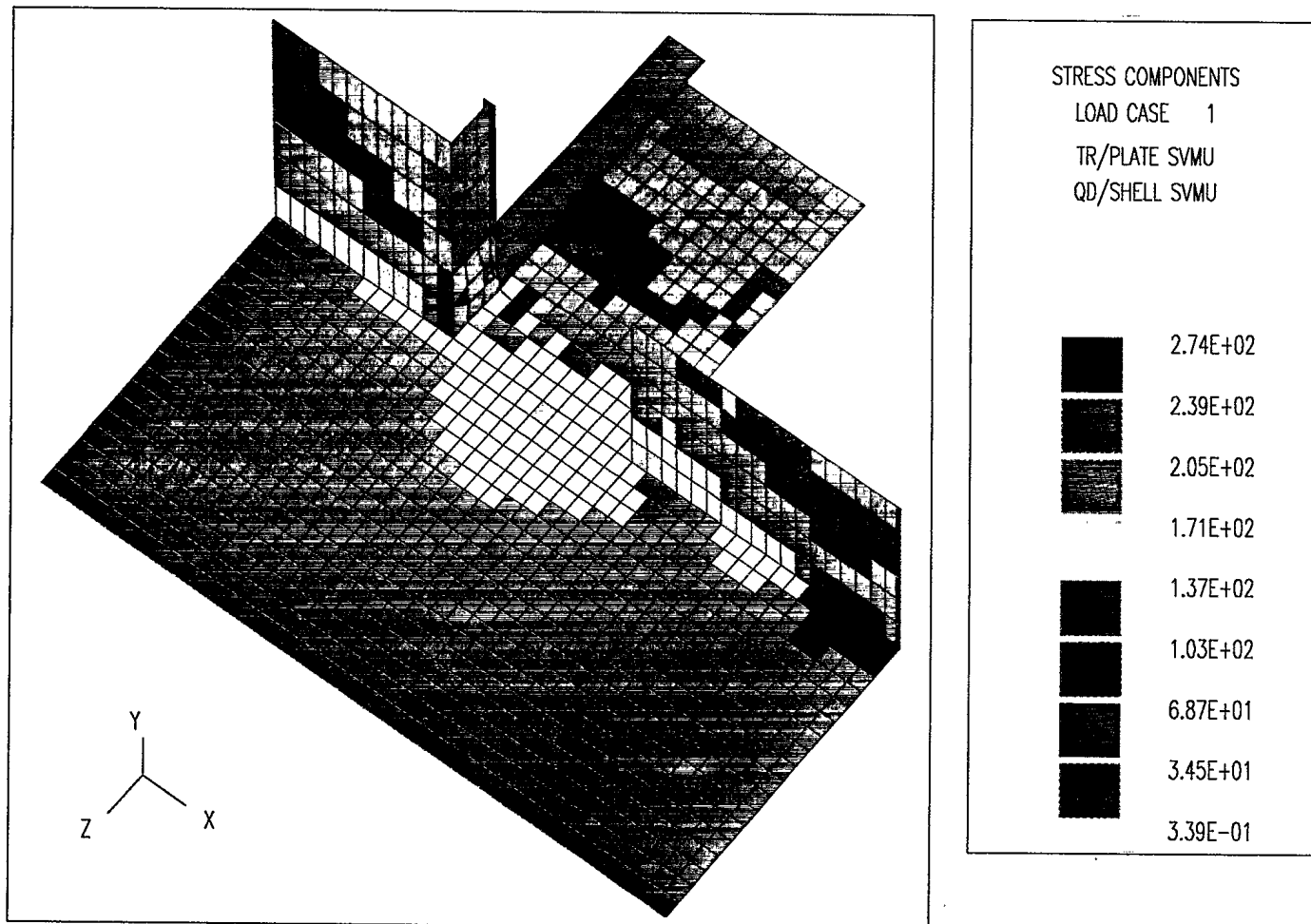

Figure 17: The Von Mises Element Stresses in the Refined Portion of the Model

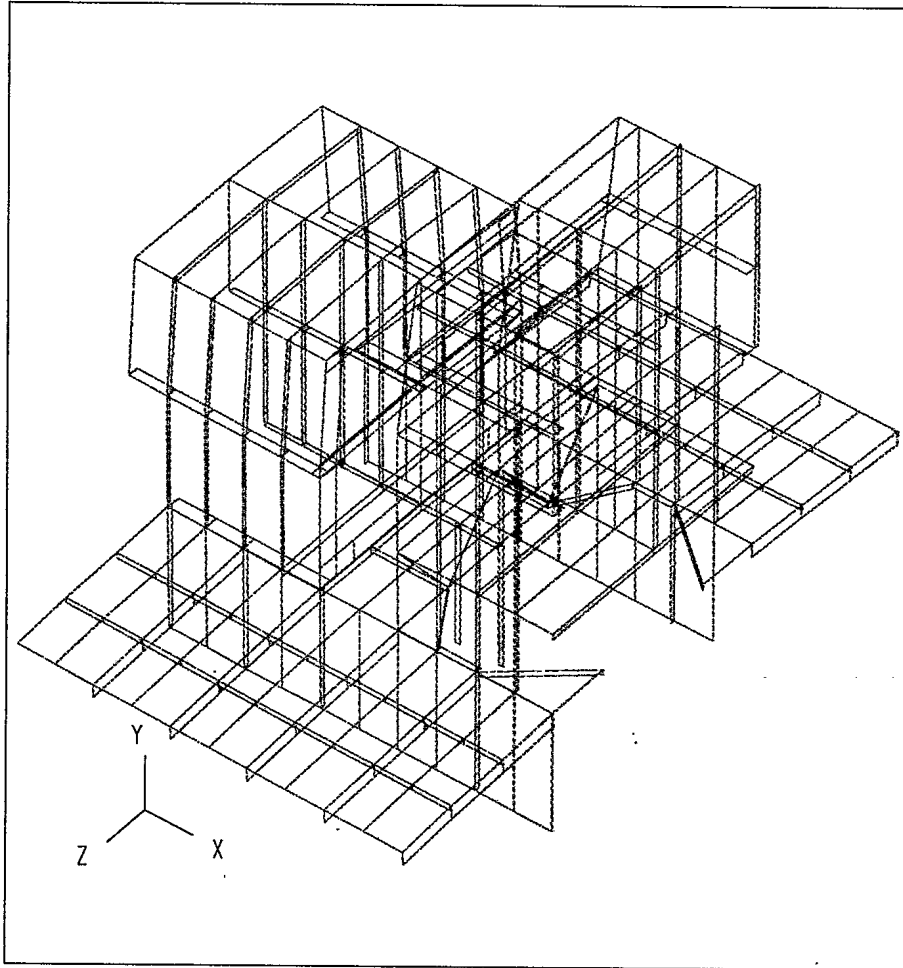

Figure 18: The MAESTRO Elements Removed to Accept the Externally Generated Model

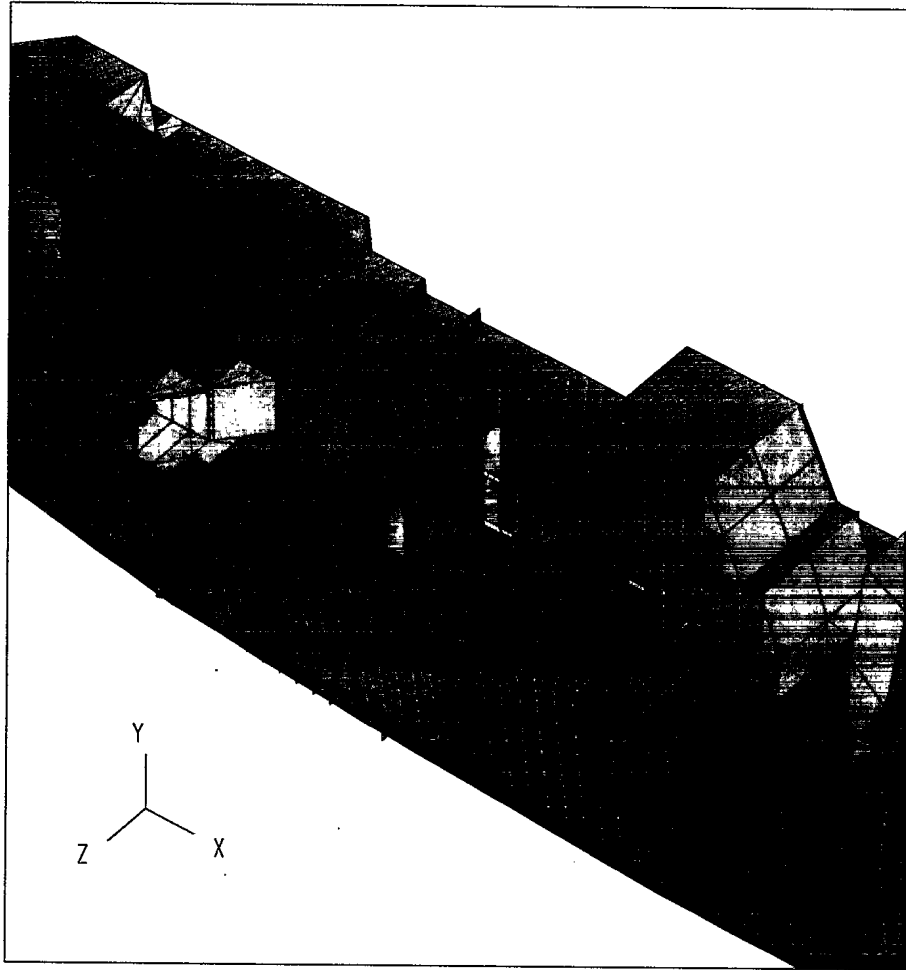

Figure 19: The MAESTRO Model with the Elements Removed

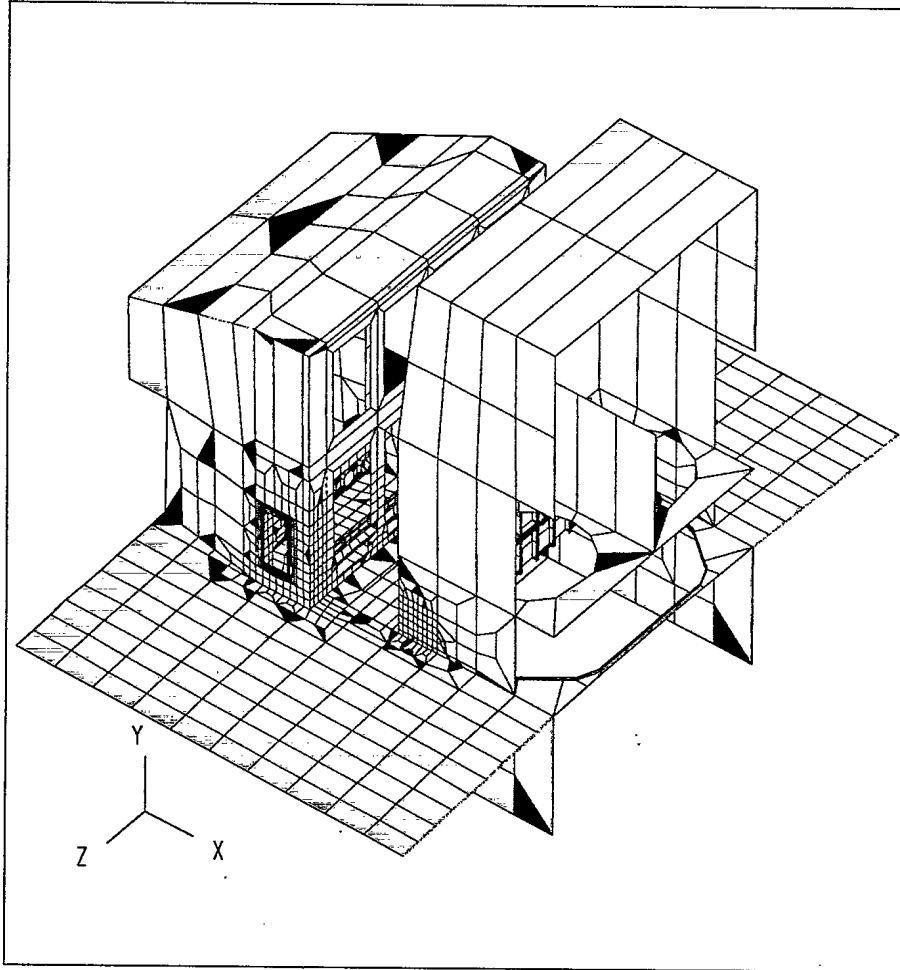

Figure 20: The Externally Generated Model

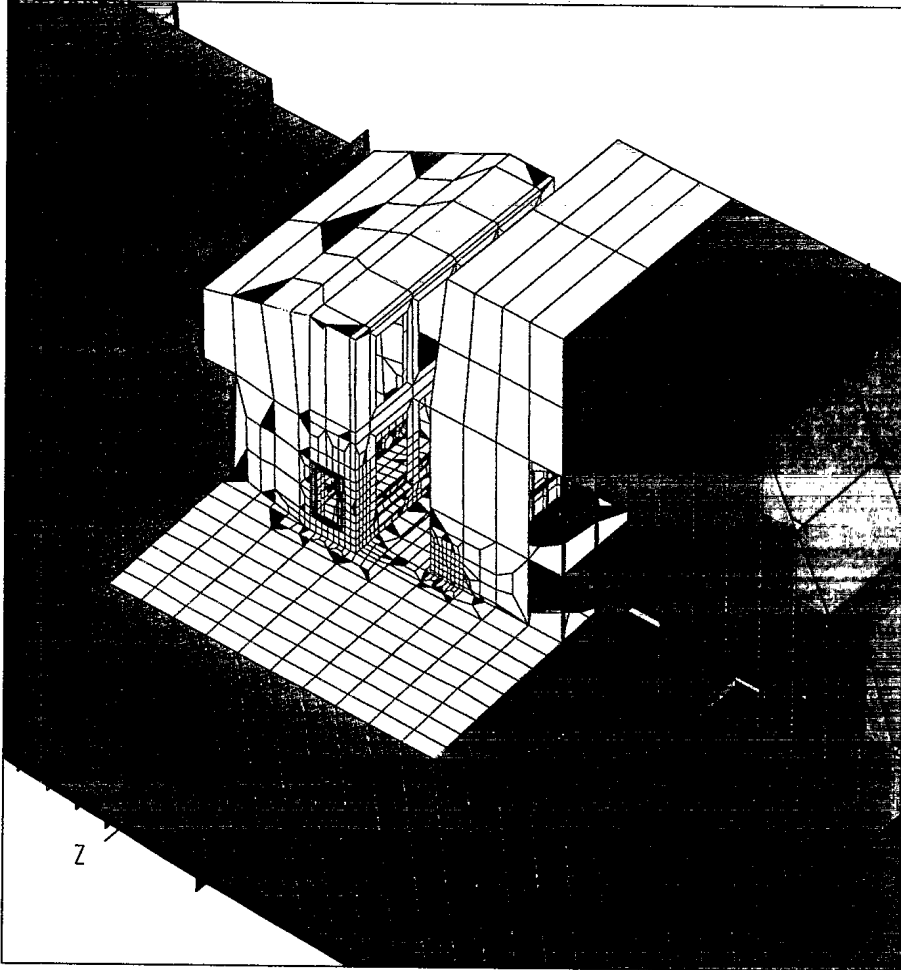

Figure 21: The Externally Generated Model Merged with the Maestro Model

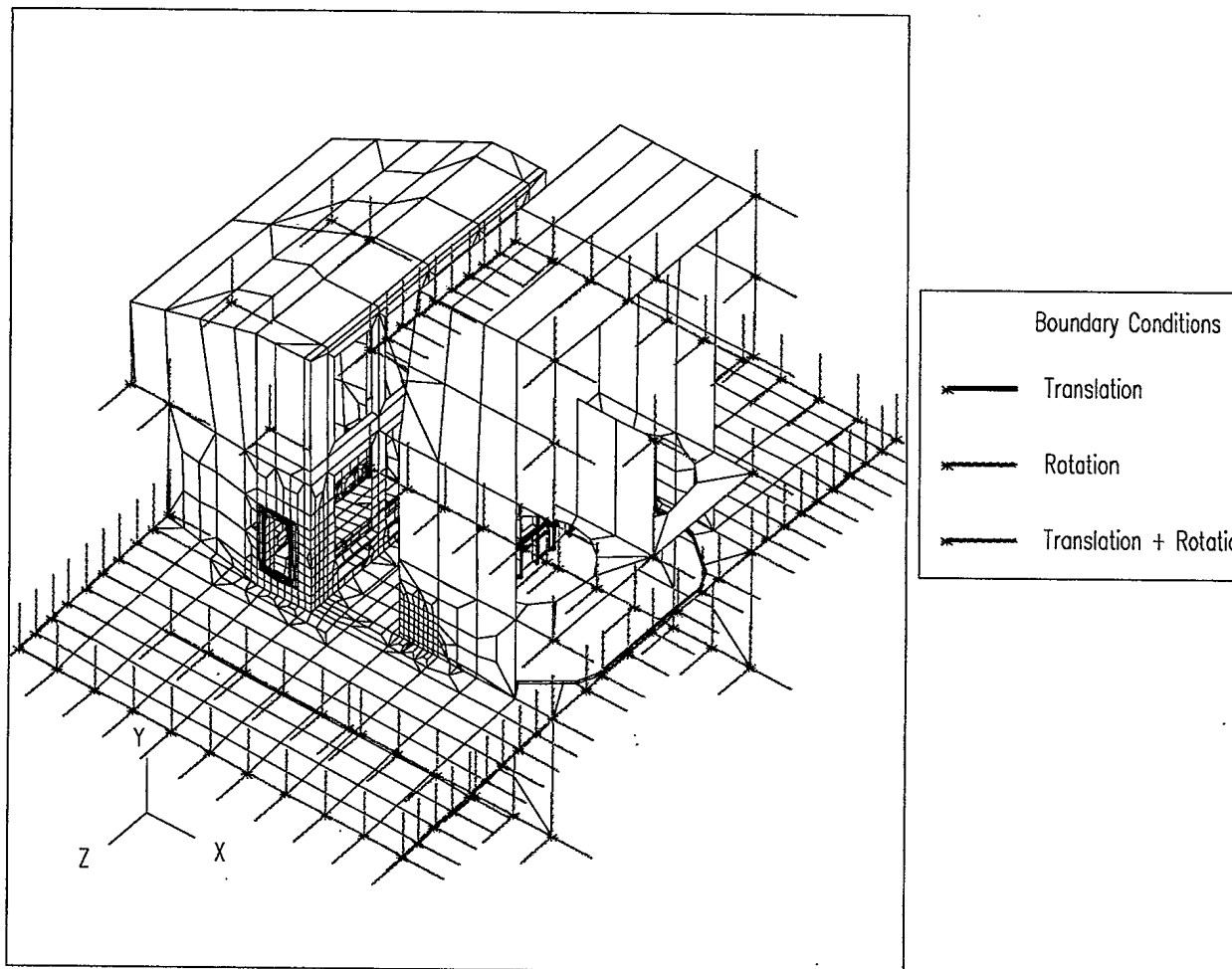

Figure 22: The Boundary Conditions Applied to the Externally Generated Model

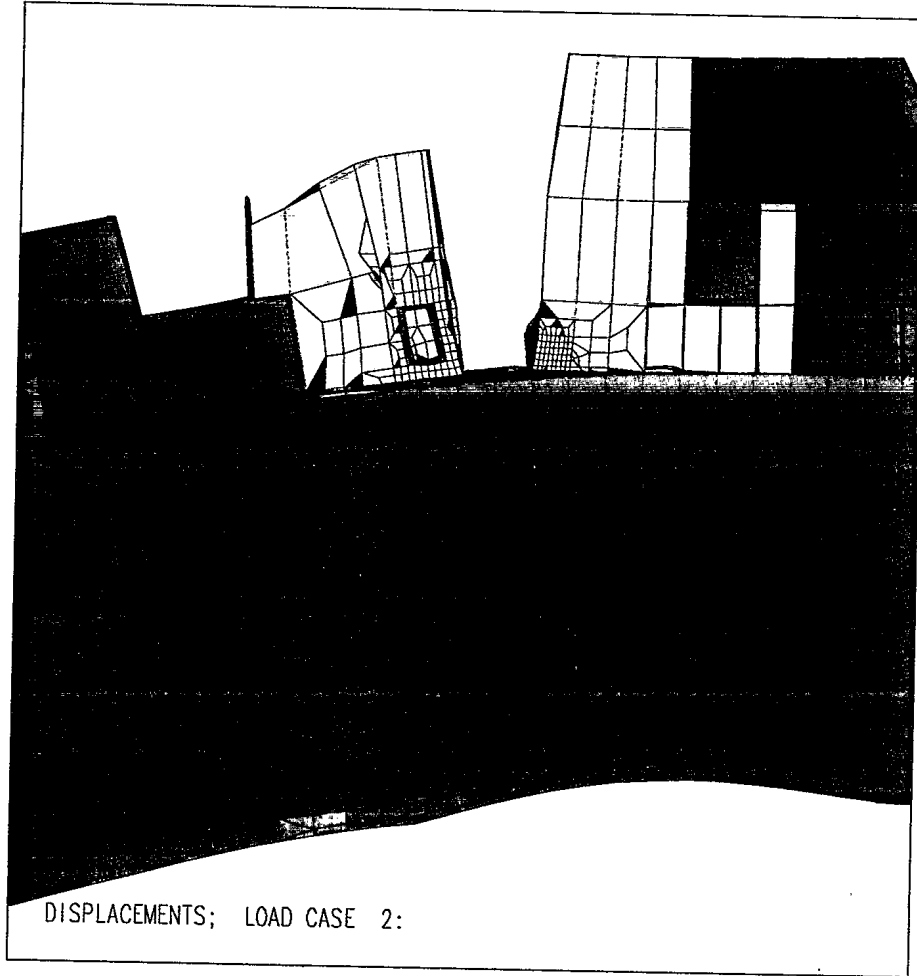

Figure 23: Distortion of the Model due to a Hogging Load

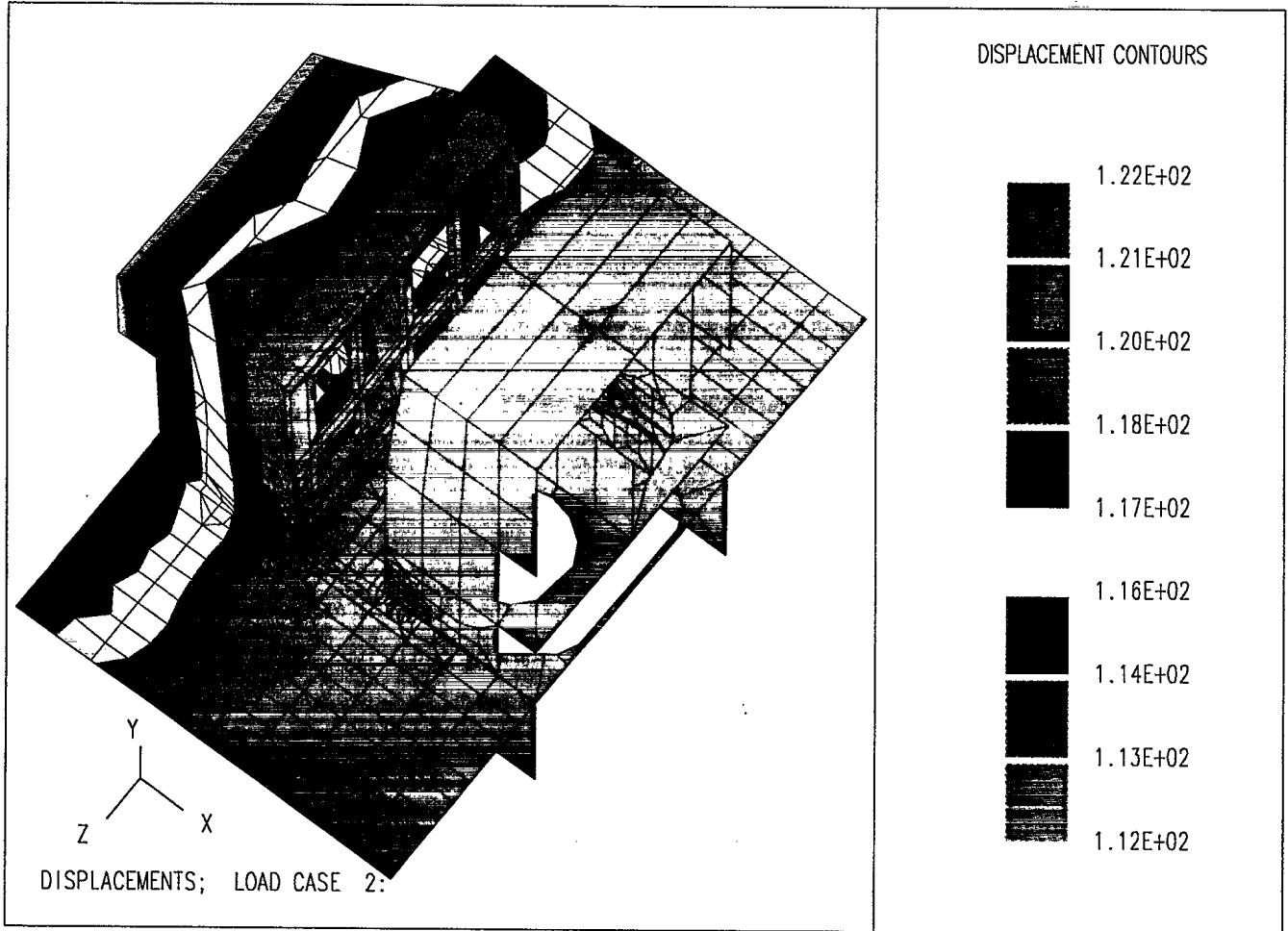

Figure 24: A Fringe Plot of the Displacements of the Externally Generated Model

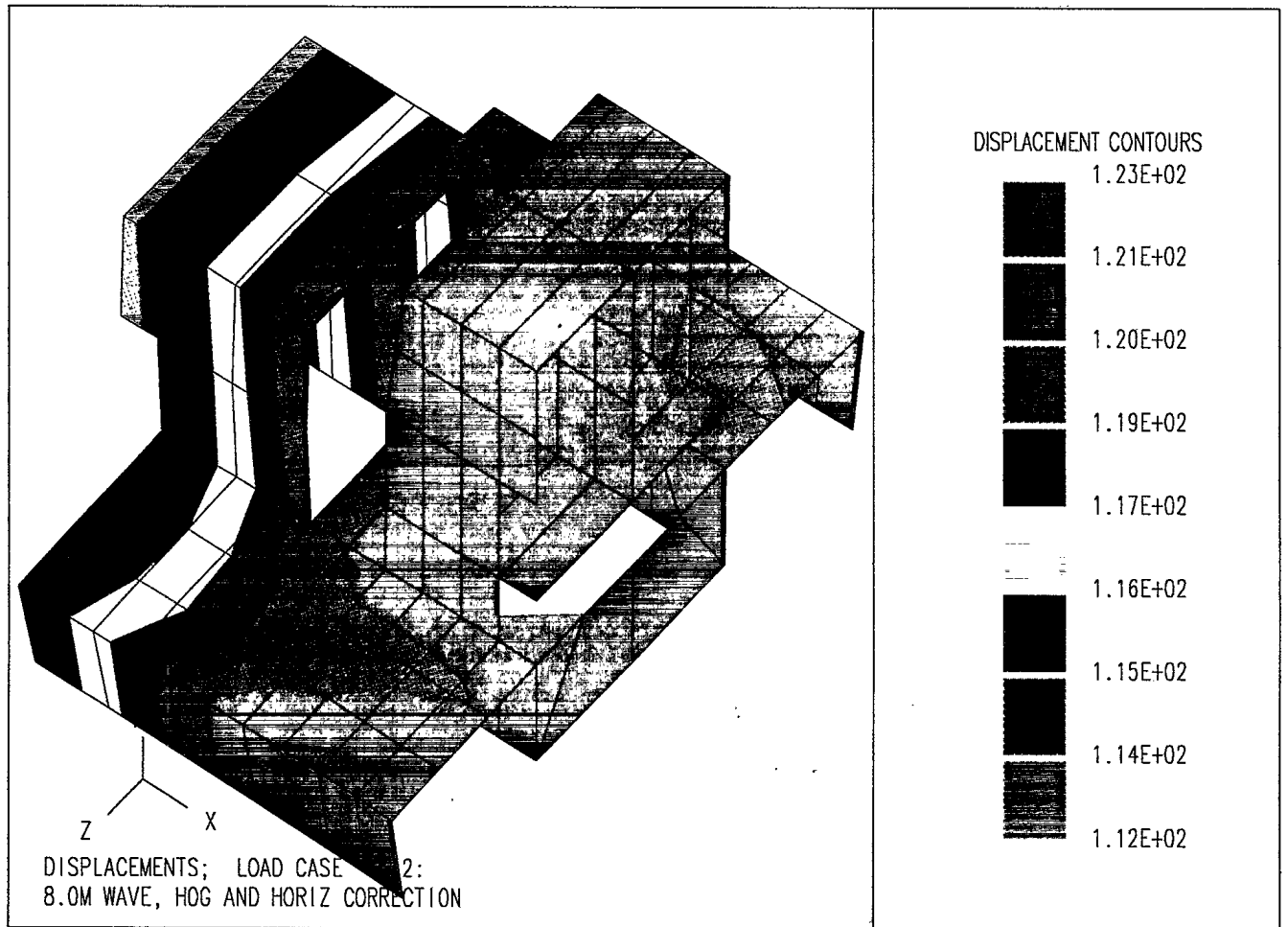

Figure 25: A Fringe Plot of the Displacements of the MAESTRO Model

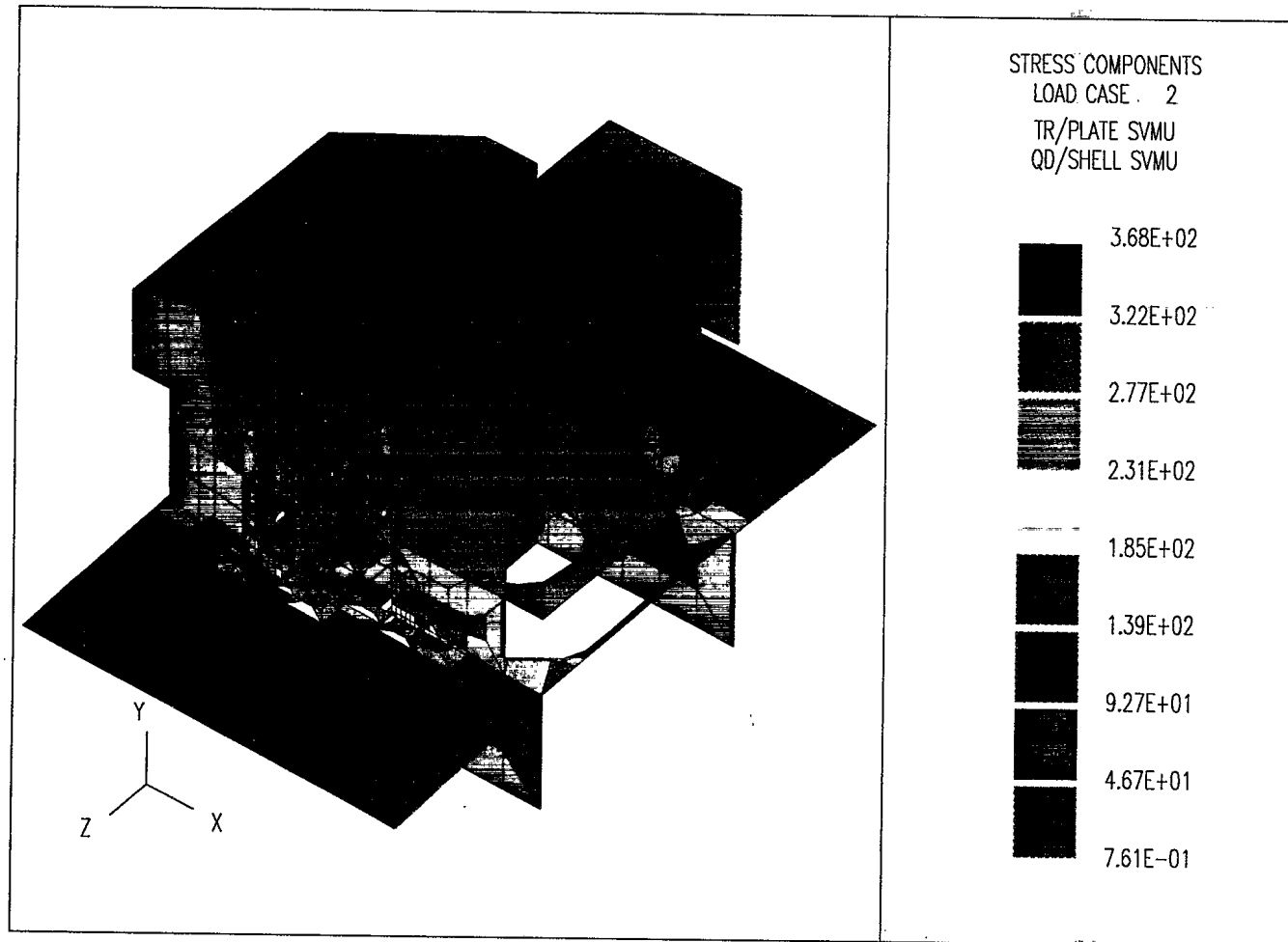

Figure 26: Von Mises Stresses in the Externally Generated Model

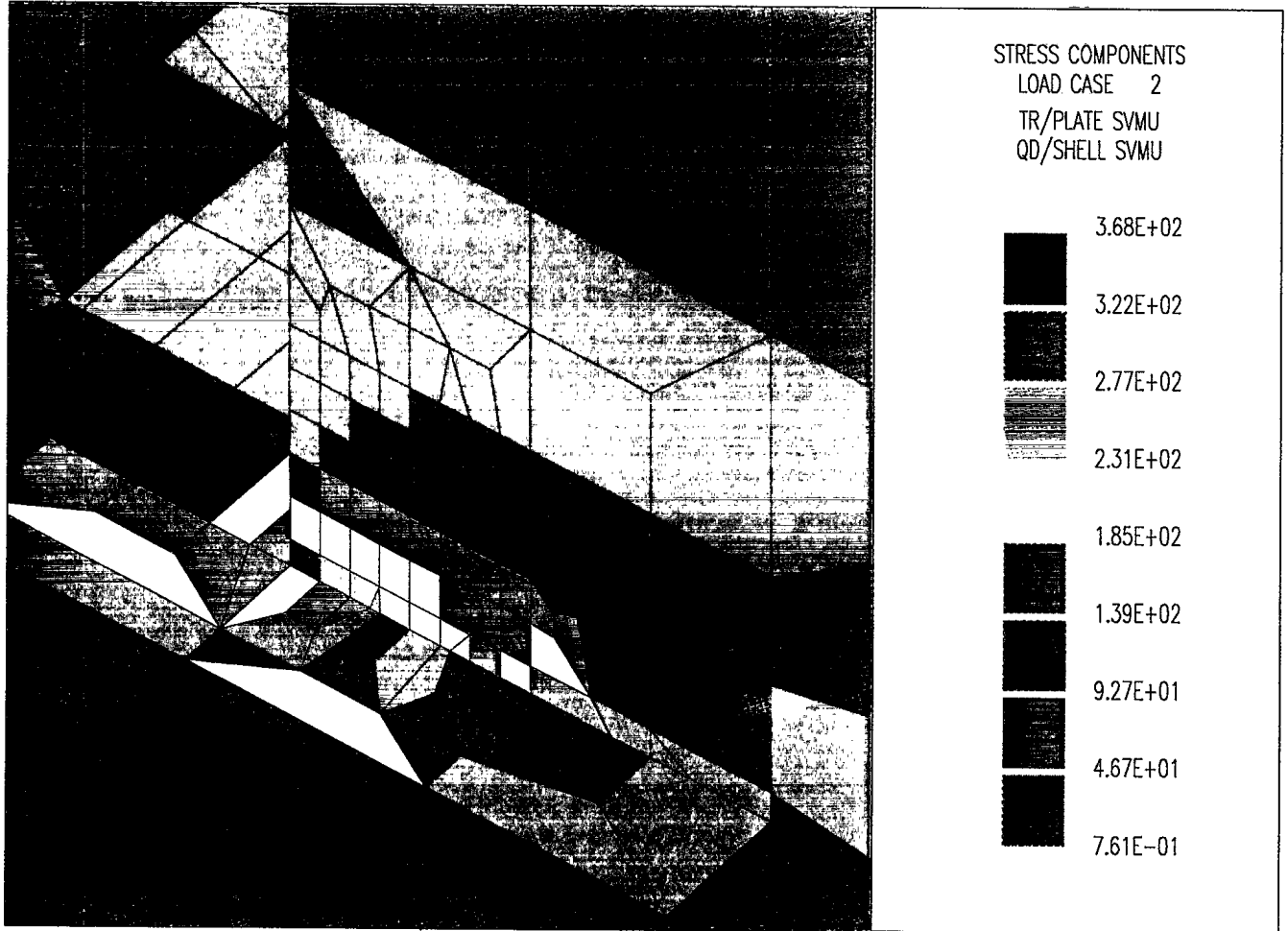

Figure 27: An Enlarged View of the High Stress in the Aft Deckhouse

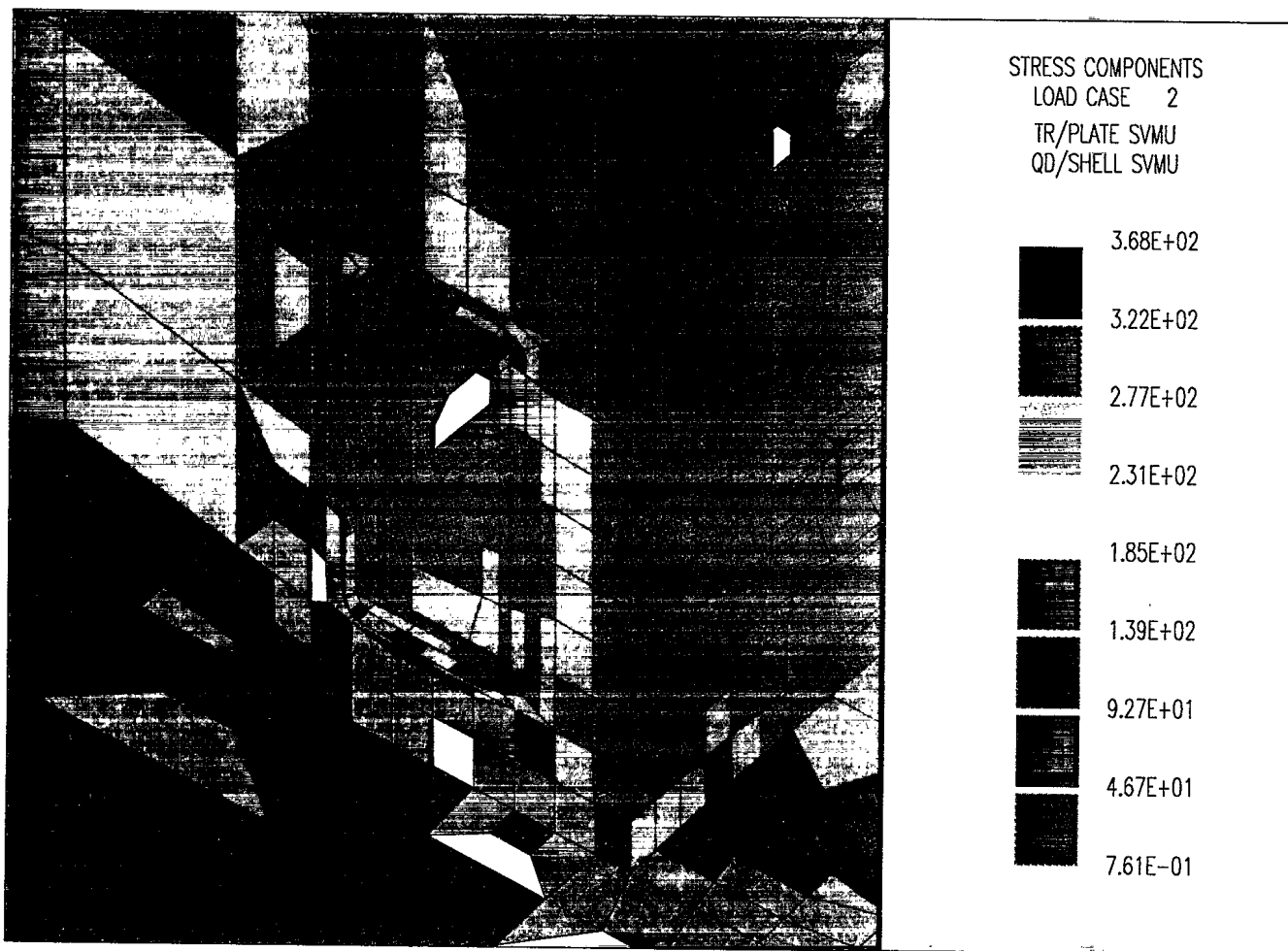

Figure 28: An Enlarged View of the High Stress in the Forward Deckhouse

References

- [1] "MAESTRO,-Method for Analysis Evaluation and Structural Optimization, User's Manual Version 6.0," distributed by Ross McNatt Naval Architects, Annapolis, MD., July 1992.
- [2] "MAESTRO Graphics," distributed by Proteus Engineering Stevensville, MD.
- [3] "Vibration And Strength Analysis Program (VAST): User's Manual Version 6.0" Martec Ltd., Halifax Nova Scotia, September, 1990.
- [4] "TRIM", Informal Communication, Theo Bosman, RNLN, Netherlands.
- [5] "HyperMesh 2.0 Documentation" Altair Computing Inc., Troy, Michigan.

UNCLASSIFIED
SECURITY CLASSIFICATION OF FORM
(highest classification of Title, Abstract, Keywords)

DOCUMENT CONTROL DATA		
(Security classification of title, body of abstract and indexing annotation must be entered when the overall document is classified)		
1. ORIGINATOR (the name and address of the organization preparing the document. Organizations for whom the document was prepared, e.g. Establishment sponsoring a contractor's report, or tasking agency, are entered in section 8.) D.R. Smith Suite 707, 5959 Spring Garden Road Halifax, N.S.	2. SECURITY CLASSIFICATION (overall security classification of the document including special warning terms if applicable). <p align="center">Unclassified</p>	
3. TITLE (the complete document title as indicated on the title page. Its classification should be indicated by the appropriate abbreviation (S,C,R or U) in parentheses after the title). <p align="center">Stress Analysis of the Canadian Patrol Frigate Under a Hogging Load Case Using MAESTRO/DSA</p>		
4. AUTHORS (Last name, first name, middle initial. If military, show rank, e.g. Doe, Maj. John E.) <p align="center">D.R. Smith</p>		
5. DATE OF PUBLICATION (month and year of publication of document) <p align="center">May 1998</p>	6a. NO OF PAGES (total containing information include Annexes, Appendices, etc). <p align="center">40</p>	6b. NO. OF REFS (total cited in document) <p align="center">5</p>
7. DESCRIPTIVE NOTES (the category of the document, e.g. technical report, technical note or memorandum. If appropriate, enter the type of report, e.g. interim, progress, summary, annual or final. Give the inclusive dates when a specific reporting period is covered). <p align="center">DREA Contractor Report</p>		
8. SPONSORING ACTIVITY (the name of the department project office or laboratory sponsoring the research and development. Include the address). Defence Research Establishment Atlantic P.O. Box 1012 Dartmouth, N.S. B2Y 3Z7		
9a. PROJECT OR GRANT NO. (if appropriate, the applicable research and development project or grant number under which the document was written. Please specify whether project or grant). Project 1gc	9b. CONTRACT NO. (if appropriate, the applicable number under which the document was written). <p align="center">W7707-6-3561</p>	
10a. ORIGINATOR'S DOCUMENT NUMBER (the official document number by which the document is identified by the originating activity. This number must be unique to this document). <p align="center">DREA CR/98/423</p>	10b. OTHER DOCUMENT NOS. (Any other numbers which may be assigned this document either by the originator or by the sponsor).	
11. DOCUMENT AVAILABILITY (any limitations on further dissemination of the document, other than those imposed by security classification) <input checked="" type="checkbox"/> Unlimited distribution <input type="checkbox"/> Distribution limited to defence departments and defence contractors; further distribution only as approved <input type="checkbox"/> Distribution limited to defence departments and Canadian defence contractors; further distribution only as approved <input type="checkbox"/> Distribution limited to government departments and agencies; further distribution only as approved <input type="checkbox"/> Distribution limited to defence departments; further distribution only as approved <input type="checkbox"/> Other (please specify):		
12. DOCUMENT ANNOUNCEMENT (any limitation to the bibliographic announcement of this document. This will normally correspond to the Document Availability (11). However, where further distribution (beyond the audience specified in 11) is possible, a wider announcement audience may be selected). <p align="center">Full, unlimited</p>		

UNCLASSIFIED
SECURITY CLASSIFICATION OF FORM

13. **ABSTRACT** (a brief and factual summary of the document. It may also appear elsewhere in the body of the document itself. It is highly desirable that the abstract of classified documents be unclassified. Each paragraph of the abstract shall begin with an indication of the security classification of the information in the paragraph (unless the document itself is unclassified) represented as (S), (C), (R), or (U). It is not necessary to include here abstracts in both official languages unless the text is bilingual).

This report describes a finite element stress analysis of the Canadian Patrol Frigate when it was subjected to a hogging load from an eight meter wave. The analysis was conducted using the program MAESTRO/DSA. Initially the analysis was performed on a global MAESTRO model of the entire ship and a region of high stress was identified. The region was refined using the DSA (Detail Stress Analysis) portion of the program and a top-down analysis was carried out by applying the displacements from the MAESTRO analysis. They were applied to the corresponding nodes of the refined portion of the MAESTRO model and detail stresses were obtained which were found to be higher than those obtained from the global MAESTRO analysis. A second refinement of the high stress region was carried out which covered a larger portion of the structure. The model was created externally using the program HYPERMESH. This larger refined portion was also subjected to a top-down analysis and stresses were obtained. The results of the three analyses are compared.

14. **KEYWORDS, DESCRIPTORS or IDENTIFIERS** (technically meaningful terms or short phrases that characterize a document and could be helpful in cataloguing the document. They should be selected so that no security classification is required. Identifiers, such as equipment model designation, trade name, military project code name, geographic location may also be included. If possible keywords should be selected from a published thesaurus. e.g. Thesaurus of Engineering and Scientific Terms (TEST) and that thesaurus-identified. If it not possible to select indexing terms which are Unclassified, the classification of each should be indicated as with the title).

finite element
stress
MAESTRO
DSA
Detailed stress analysis
hog
top-down

UNCLASSIFIED
SECURITY CLASSIFICATION OF FORM

**D
R
E
A**



**C
R
D
A**

#576002