



REFERENCE ONLY

NAVAL UNDERWATER SYSTEM CENTER
NEW LONDON LABORATORY
NEW LONDON, CONNECTICUT 06320

Technical Memorandum

LASER VELOCIMETER OPERATION
IN THE WATER TUNNEL

Date: 1 April 1985

Prepared by:

Virgil A. Sandborn
Virgil A. Sandborn
Submarine Sonar Department

Approved for Public Release: Distribution Unlimited

REFERENCE ONLY

Report Documentation Page

Form Approved
OMB No. 0704-0188

Public reporting burden for the collection of information is estimated to average 1 hour per response, including the time for reviewing instructions, searching existing data sources, gathering and maintaining the data needed, and completing and reviewing the collection of information. Send comments regarding this burden estimate or any other aspect of this collection of information, including suggestions for reducing this burden, to Washington Headquarters Services, Directorate for Information Operations and Reports, 1215 Jefferson Davis Highway, Suite 1204, Arlington VA 22202-4302. Respondents should be aware that notwithstanding any other provision of law, no person shall be subject to a penalty for failing to comply with a collection of information if it does not display a currently valid OMB control number.

1. REPORT DATE 01 APR 1985		2. REPORT TYPE Technical Memo		3. DATES COVERED 01-04-1985 to 01-04-1985	
4. TITLE AND SUBTITLE Laser Velocimeter Operation in the Water Tunnel				5a. CONTRACT NUMBER	
				5b. GRANT NUMBER	
				5c. PROGRAM ELEMENT NUMBER	
6. AUTHOR(S) Virgil Sandborn				5d. PROJECT NUMBER A70201	
				5e. TASK NUMBER	
				5f. WORK UNIT NUMBER	
7. PERFORMING ORGANIZATION NAME(S) AND ADDRESS(ES) Naval Underwater Systems Center, New London, CT, 06320				8. PERFORMING ORGANIZATION REPORT NUMBER TM No. 851099	
9. SPONSORING/MONITORING AGENCY NAME(S) AND ADDRESS(ES)				10. SPONSOR/MONITOR'S ACRONYM(S)	
				11. SPONSOR/MONITOR'S REPORT NUMBER(S)	
12. DISTRIBUTION/AVAILABILITY STATEMENT Approved for public release; distribution unlimited					
13. SUPPLEMENTARY NOTES NUWC2015					
14. ABSTRACT A two component laser velocimeter is to be used to measure the mean and turbulent velocity distributions over a compliant surface in the water tunnel. Measurements very close to the surface will require operation of the laser velocimeter at slight angles of tilt to the horizontal plane. The present memo is an evaluation of the effect of the index of refraction of the window and water on the location of the velocimeter sample volumes in the flow. The angles of tilt of the system produce shifts in the locations of the vertical and horizontal beam crossings such that they no longer coincide.					
15. SUBJECT TERMS water tunnel; velocimeter; flow noise reduction for mobile acoustic sensors					
16. SECURITY CLASSIFICATION OF:			17. LIMITATION OF ABSTRACT Same as Report (SAR)	18. NUMBER OF PAGES 10	19a. NAME OF RESPONSIBLE PERSON
a. REPORT unclassified	b. ABSTRACT unclassified	c. THIS PAGE unclassified			

ABSTRACT

A two component laser velocimeter is to be used to measure the mean and turbulent velocity distributions over a compliant surface in the water tunnel. Measurements very close to the surface will require operation of the laser velocimeter at slight angles of tilt to the horizontal plane. The present memo is an evaluation of the effect of the index of refraction of the window and water on the location of the velocimeter sample volumes in the flow. The angles of tilt of the system produce shifts in the locations of the vertical and horizontal beam crossings such that they no longer coincide.

ADMINISTRATIVE INFORMATION

This technical memorandum was prepared under NUSC IR Project No. A70201, "Flow Noise Reduction for Mobile Acoustic Sensors," Principle Investigator, Dr. H. P. Bakewell Jr. (Code 3232). The work was performed by the author, Professor V. A. Sandborn of Colorado State University, during a one year IPA assignment at the Naval Underwater Systems Center.

INTRODUCTION

The use of two component-laser velocimeters to evaluate the instantaneous horizontal and vertical velocities at a point in a turbulent flow field is of great value. The measurements are normally carried out in flows where the view of the field is not restricted. For the present application the surface over which the flow is to be measured can only be viewed from an oblique angle. Thus, measurements near the surface with the laser light beams will require operation with the plane of the beams tilted with respect to the horizontal. The effect of oblique angles at the window and water interfaces due to refraction can produce large deflections of the beams. The deflections will be such that the sets of vertical and horizontal beams do not cross at coincident points.

REFRACTION EVALUATION

Table I lists the properties of the laser velocimeter and test section to be used in the present study.

Table I

Fringe Spacing, d_f		Lens Focal Length	Beam Angle ϕ	Wave length, λ	
Green	Blue			Green	Blue
2.670 μm	2.532 μm	249.7mm	5.529°	514.5 \AA	488.0 \AA
5.270 μm	4.998 μm	500.0mm	2.798°		

Window thickness 2.5 inches, Plexiglass ($n = 1.48$)
 Tunnel centerline 3.5 inches from inside of the window
 (note: $\mu\text{m} = 10^{-6}$ meters; $\text{\AA} = 10^{-9}$ meters)

The fringe spacing, d_f , is determined by the relation

$$d_f = \frac{\lambda}{2 \sin \phi} \tag{1}$$

The wave length, λ , for the particular laser system is fixed and would be expected to remain constant independent of any external effects. For calibration of the laser system, the measure of the beam angle is critical. The angle depends on the focal length of the lens used to create the beam crossing. The angle is also dependent on the spacing of the beams when they are focused by the lens. The angle should also remain fixed as a physical property of the system. Care must be taken to insure that the alignment of the laser system does not alter the spacing of the beams.

When the laser beam enters another medium, such as the plastic window or the water, the wave length of the light changes. For the light beam entering the medium at other than 90 degrees to the interface the beam is refracted to a new angle different from that of the incident light beam. It is found for

symmetrical conditions that the changes in λ and ϕ in the new medium are such that the fringe spacing d_f will not be changed.

REFRACTION AT A PLANE SURFACE - The angle of refraction, ϕ , of a light beam entering a fluid with an index of refraction different from the original medium, figure 1a), is given by Snell's Law

$$n_1 \sin \phi = n_2 \sin \phi' \quad (2)$$

where n_1 and n_2 are the index of refraction of fluids 1 and 2. For the present application the first fluid will be air with an index of refraction of 1. As noted in Table I, the index of refraction of the window is assumed to be 1.48. For water the index of refraction is taken to be 1.33. Obviously, for accurate evaluation of the effects in the water tunnel it is desirable to experimentally determine the values accurately.

The effect of refraction on the laser velocimeter is demonstrated in figure 1b). The actual crossing point of the beams is extended further into the fluid than the point corresponding to the case of no refraction.

For the present water tunnel geometry, shown in figure 2, the angles are:

$$\sin \phi = n_w \sin \phi' = n_f \sin \phi'' \quad (3)$$

$$\begin{aligned} \text{for } \phi &= 5.529^\circ \text{ (Table I), } n_w = 1.48 \text{ and } n_f = 1.33, \\ \phi' &= 3.733^\circ \\ \phi'' &= 4.154^\circ \end{aligned}$$

From figure 2 the distance Z_f at which two beams, symmetrically spaced about the axial line cross, can be related to the distance Z_a and the window thickness, t , by the relation

$$Z_f = Z_a \left[\frac{\tan \phi}{\sin \phi} \left(1 - \frac{\sin^2 \phi}{n_f^2} \right)^{1/2} \right] - t \left[\frac{n_f}{n_w} \frac{\tan \phi'}{\sin \phi'} \left(1 - \frac{\sin^2 \phi}{n_f^2} \right) \right] \quad (4)$$

Note that for small angles ϕ and ϕ' ; $\tan \phi = \sin \phi$ and $\sin^2 \phi / n_f^2$ can be neglected compared to 1. Thus, equation (4) can be approximated as

$$Z_f = n_f Z_a - \frac{n_f}{n_w} t$$

For the present system equation (4) becomes (dimensions in inches)

$$Z_f = 1.333 Z_a - 2.245 \quad (5)$$

If the initial actuator traverse is set so the beams just cross at the outside surface of the window, then the traverse must be moved in a distance, Z_a , equal to 4.380 inches for the beams to cross at the centerline (3.5 inches from the inside of the window). The movement of the crossing is magnified by roughly the index of refraction of the water.

Equation (4) is for the ideal case where the beams are in planes that are perpendicular to the window. For this symmetrical case the two component laser system can only be lowered to 0.424 inches above the bottom surface. Further lowering will block off the lower beam of the vertical set. Thus, it is desirable to tilt the laser system to obtain data closer to the surface.

REFRACTION AT AN OBLIQUE SURFACE - Figure 3 shows possible geometries that will be encountered for the proposed water tunnel studies. The tilted beams produce a three-dimensional refraction of the horizontal set of beams and a non-symmetrical refraction of the vertical beams. It also appears critical that no secondary angularity (i.e., plane of the vertical beams must be perpendicular to the window and the plane of the horizontal beams must intersect the window parallel to the surface) is present, since slight misalignment would cause the beams not to cross.

Vertical Beam Parallel to the Surface - For this special case the parallel, vertical beam is not refracted, since it is perpendicular to the surface. We need only investigate the refraction of the upper vertical beam to determine where it will intersect the parallel beam. The angles for the particular problem are shown on figure 4a).

The deflection of the upper vertical beam is equivalent to the plane refraction problem of figure 2. The crossing distance is obtained from equation (4), where the incident angle is double that used to obtain equation (5)

$$Z_{fV} = 1.341Z_{aV} - 2.242 \quad (6)$$

The horizontal beams make oblique angles with the surface, so the crossing point is deflected both in the vertical and horizontal directions, as shown in figure 4b). Both the horizontal beams are deflected equally downward, so the top view can be employed to determine the crossing point. The incident angle is changed from 5.529 to 5.555 degrees due to the rotation. From equation (4) the relation for the crossing distance, Z_{fH} , becomes

$$Z_{fH} = 1.333Z_{aH} - 2.245 \quad (7)$$

which is identical to four significant figures with equation (5). Equation (7) is slightly in error, since the beam traverses more than $t (= 2.5$ inches) thickness of the window. (The thickness should be increased by roughly 1.004.) The distances Z_{fH} and Z_{aH} are in the direction of the incident beam, as shown in the side view.

We can compute the vertical location of the beam crossing by considering the side view of figure 4b). The values computed by equation (7), (with the intercept increased to 2.255) may be employed to locate the beam crossing point, Z_{fH} . The distance Δy is approximately given by the relation

$$\Delta y = \sin \phi \left[Z_{fH} \left(1 - \frac{1}{n_f} \right) + t \left(\tan \phi - \frac{1}{n_w} \right) \right] \quad (8)$$

(The approximation; $l = Z_{fH} \cos(\phi - \phi'') \approx Z_{fH}$, was employed to obtain equation (8)).

Referring to figure 4c), the difference in location of the crossing points of the horizontal and vertical beams is noted. For the case where the vertical beams cross at the centerline the value of $Z_{av} = 4.282$ inches, and $Z_{aH} = Z_{av} / \cos 5.529 = 4.302$ inches. Thus, $Z_{fH} = 3.490$ inches (3.481 inches with the thickness correction) and $Z_{fH} \cos 5.529 = 3.473$ inches (3.465 inches corrected) would be distance along the parallel-vertical beam from the window. The ΔZ difference in the crossing of the vertical and horizontal beams is approximately $\Delta Z \approx 3.500 - 3.473 \approx 0.027$ inches (0.035 inches corrected). The vertical distance Δy computed from equation (8) is 0.056 inches (thickness correction does not change this value). The crossing volume is of the order of 0.005 inches in diameter and 0.02 inches in length. If the horizontal beams could be deflected to cross on the parallel-vertical beam ($\Delta y \approx 0$) the crossings would share some common intersection. A downward displacement of the horizontal beams by the Δy mismatch may be feasible. Also a slight increase in the horizontal beam spacing would increase the value of Z_{fH} to improve the change of coincidence.

The case where the tilt angle is greater than the lens angle, figure 3b), will further increase the mismatch of the crossing points. Again it is conceivable that the optics can be adjusted to deflect the individual sets of beams to slightly different locations or spacings to bring the crossings together. Slight alignment adjusts are possible with the existing optics, and further deflections can be made employing the refraction effect.

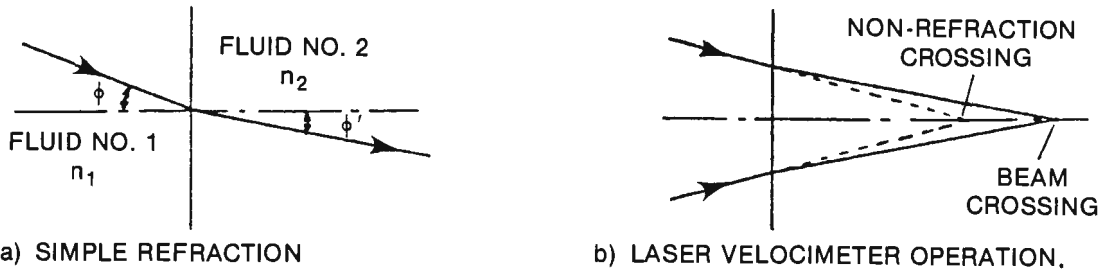

FIGURE 1. REFRACTION OF LIGHT BEAMS.

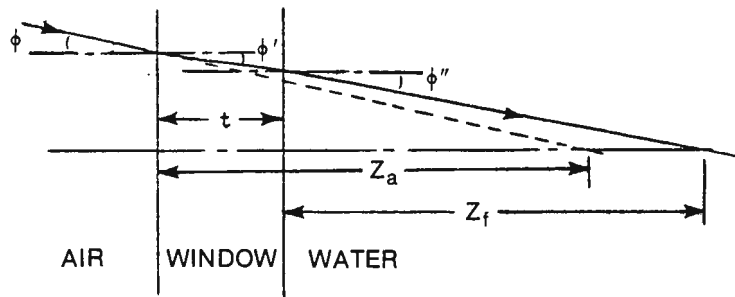

FIGURE 2. REFRACTION OF THE LASER BEAM IN THE WATER TUNNEL.

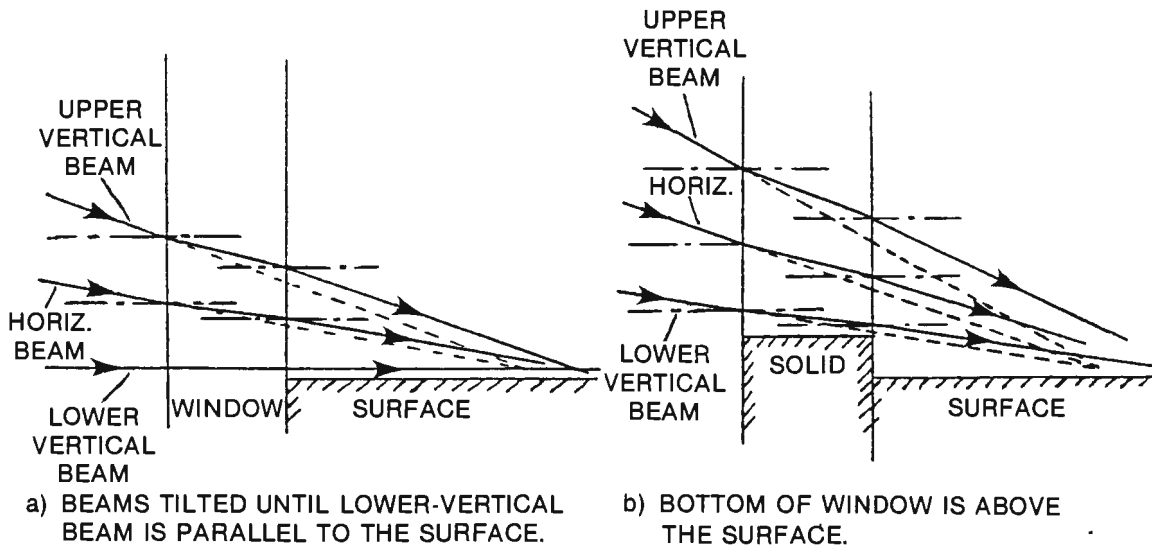

FIGURE 3. TILTED BEAM LASER VELOCIMETER OPERATION.

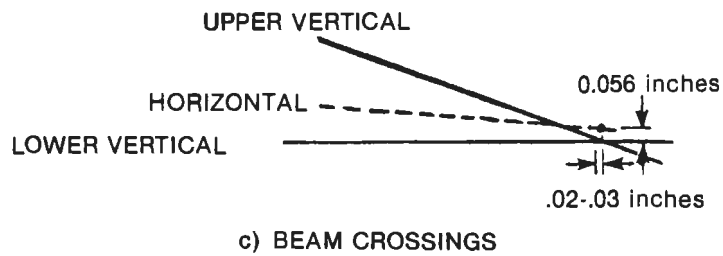
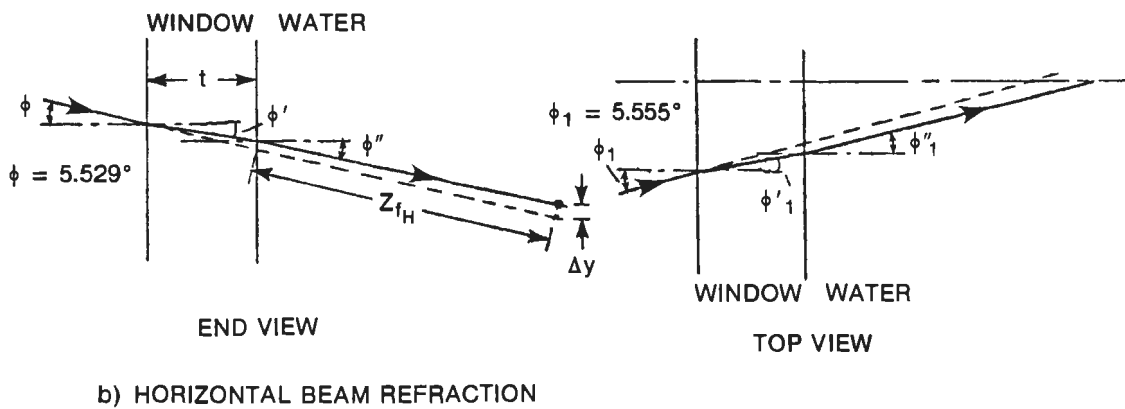
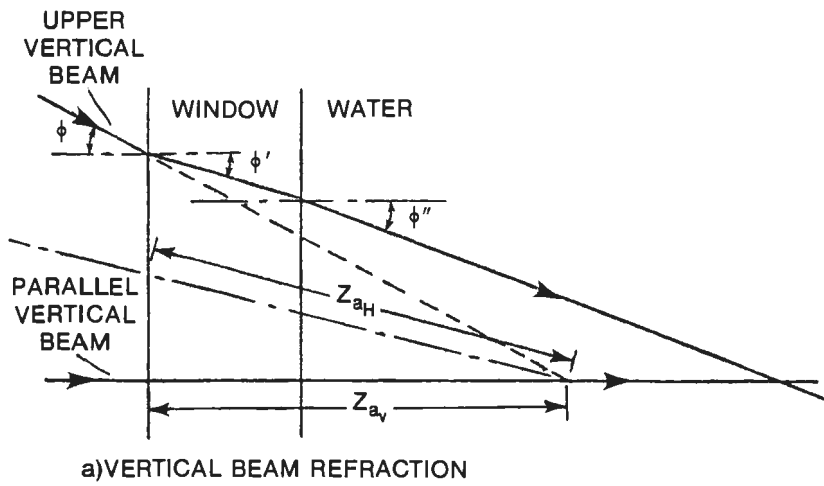

FIGURE 4. TILTED BEAM GEOMETRY.

Internal

Code 03 (L. Goodman)
Code 10
Code 10 (E. Uram, R. Elswick)
Code 323
Code 3232
Code 3232 (H. Bakewell (8), B. Cano, M. Johnson, D. Lehman)
Code 3322 (M. Cerza)
Code 363
Code 3634 (P. Gibson)
Code 3711 (P. LeFebvre)
Code 02111 (R. Bernier (1))
Code 021311 (New London (2))
Code 021312 (Newport (1))

LASER VELOCIMETER OPERATION IN THE WATER TUNNEL

V. A. Sandborn

Submarine Sonar Department

TM 851099

1 April 1985

Approved for public release: distribution unlimited

UNCLASSIFIED

DISTRIBUTION LIST

External

NRL (R. J. Hansen Code 5844)

Colorado State University (Prof. V. A. Sandborn)

Gould, Inc., Newport, RI (J. Meng, J. Lovett)