



CMMI[®] Version 1.2 and Beyond

SEPG 2007 Conference
March 26, 2007

Mike Phillips
Software Engineering Institute
Carnegie Mellon University

® CMMI is registered in the U.S. Patent and Trademark Office by Carnegie Mellon University.
With thanks to Denise Cattan, Sandra Cepeda, Pascal Rabbath, and Gary Wolf for contributions.

Report Documentation Page

Form Approved
OMB No. 0704-0188

Public reporting burden for the collection of information is estimated to average 1 hour per response, including the time for reviewing instructions, searching existing data sources, gathering and maintaining the data needed, and completing and reviewing the collection of information. Send comments regarding this burden estimate or any other aspect of this collection of information, including suggestions for reducing this burden, to Washington Headquarters Services, Directorate for Information Operations and Reports, 1215 Jefferson Davis Highway, Suite 1204, Arlington VA 22202-4302. Respondents should be aware that notwithstanding any other provision of law, no person shall be subject to a penalty for failing to comply with a collection of information if it does not display a currently valid OMB control number.

1. REPORT DATE 26 MAR 2007		2. REPORT TYPE		3. DATES COVERED 00-00-2007 to 00-00-2007	
4. TITLE AND SUBTITLE CMMI Version 1.2 and Beyond				5a. CONTRACT NUMBER	
				5b. GRANT NUMBER	
				5c. PROGRAM ELEMENT NUMBER	
6. AUTHOR(S)				5d. PROJECT NUMBER	
				5e. TASK NUMBER	
				5f. WORK UNIT NUMBER	
7. PERFORMING ORGANIZATION NAME(S) AND ADDRESS(ES) Carnegie Mellon University ,Software Engineering Institute (SEI),Pittsburgh,PA,15213				8. PERFORMING ORGANIZATION REPORT NUMBER	
9. SPONSORING/MONITORING AGENCY NAME(S) AND ADDRESS(ES)				10. SPONSOR/MONITOR'S ACRONYM(S)	
				11. SPONSOR/MONITOR'S REPORT NUMBER(S)	
12. DISTRIBUTION/AVAILABILITY STATEMENT Approved for public release; distribution unlimited					
13. SUPPLEMENTARY NOTES Software Engineering Process Group (SEPG 2007), 26-29 Mar, Austin, TX.					
14. ABSTRACT					
15. SUBJECT TERMS					
16. SECURITY CLASSIFICATION OF:			17. LIMITATION OF ABSTRACT	18. NUMBER OF PAGES	19a. NAME OF RESPONSIBLE PERSON
a. REPORT	b. ABSTRACT	c. THIS PAGE			
unclassified	unclassified	unclassified	Same as Report (SAR)	123	



CMMI Today



Selected CMMI® Data (FY06)

17,630 Trained in Introduction to CMMI

Net increase of:

- 108 Authorized Introduction to CMMI Instructors**
 - 45 Authorized SCAMPI Lead Appraisers**
 - 84 Authorized SCAMPI B/C Team Leads**

744 SCAMPI V1.1 Class A Appraisals conducted and reported to the SEI

417 Publicly Reported SCAMPI V1.1 Class A Appraisals on the SEI Web Site



Transition from V1.1 to V1.2 Status - 12-31-06

Introduction to CMMI Students

- Registered for Upgrade Training – 1275
- Upgrades Complete – 717

Lead Appraisers and Instructors

- Registered for Upgrade Training – 621
- Upgrade Training Complete – 419

CMMI Transition Status – 12/31/06

Training

Introduction to CMMI – 59,434 trained

Intermediate CMMI – 2,367 trained

Introduction to CMMI Instructors – 477

SCAMPI Lead Appraisers – 684 trained

SCAMPI B&C-Only Team Lead -- 33

Authorized

Introduction to CMMI V1.1 Instructors – 408

SCAMPI V1.1 Lead Appraisers – 455

SCAMPI B&C Team Leads -- 456



CMMI Adoption Trends

CMMI Web pages views in
September 2006

- 360K/month
- Exceeded 24K/day

The following were the most
downloaded files on the SEI
Web site in September 2006:

- CMMI-DEV, V1.2 (PDF
Version)
- CMMI V1.1 Overview
Presentation
- CMMI V1.2 Overview
Presentation
- CMMI-DEV, V1.2 (Word
Version)
- CMMI V1.2 Model Changes
Presentation

Average daily page views per quarter

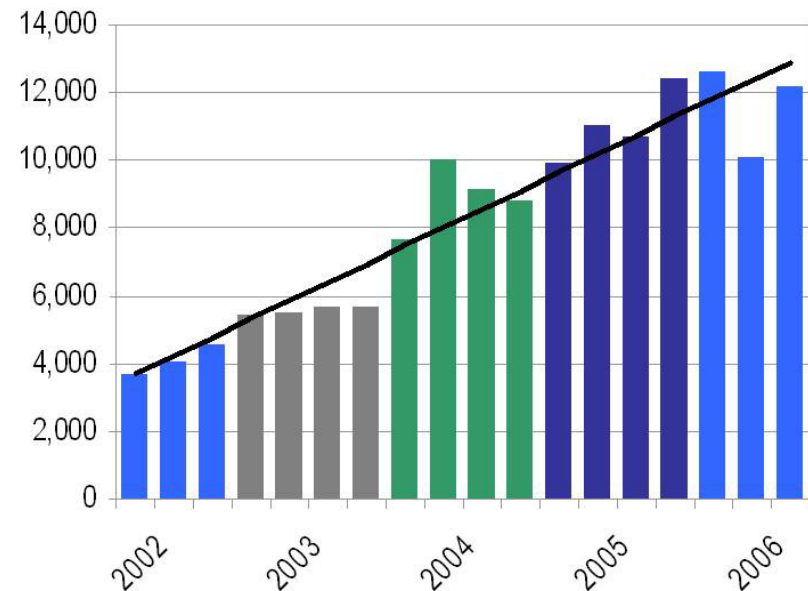



Number of CMMI Students Trained (Cumulative)

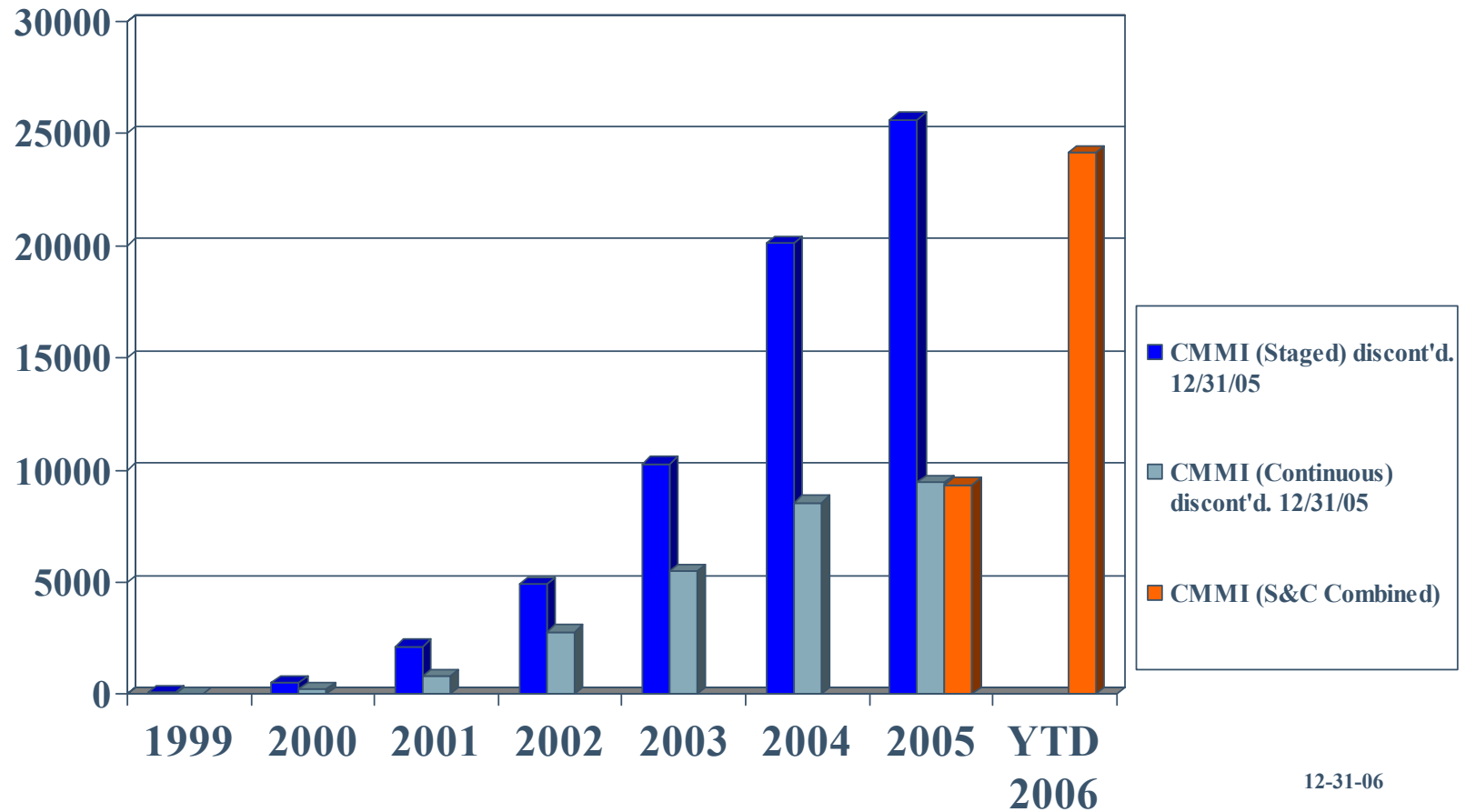

12-31-06

**Number of SCAMPI V1.1/V1.2, CMMI V1.1/V1.2, Class A Appraisals
Conducted by Year
Reported as of 31 December 2006**

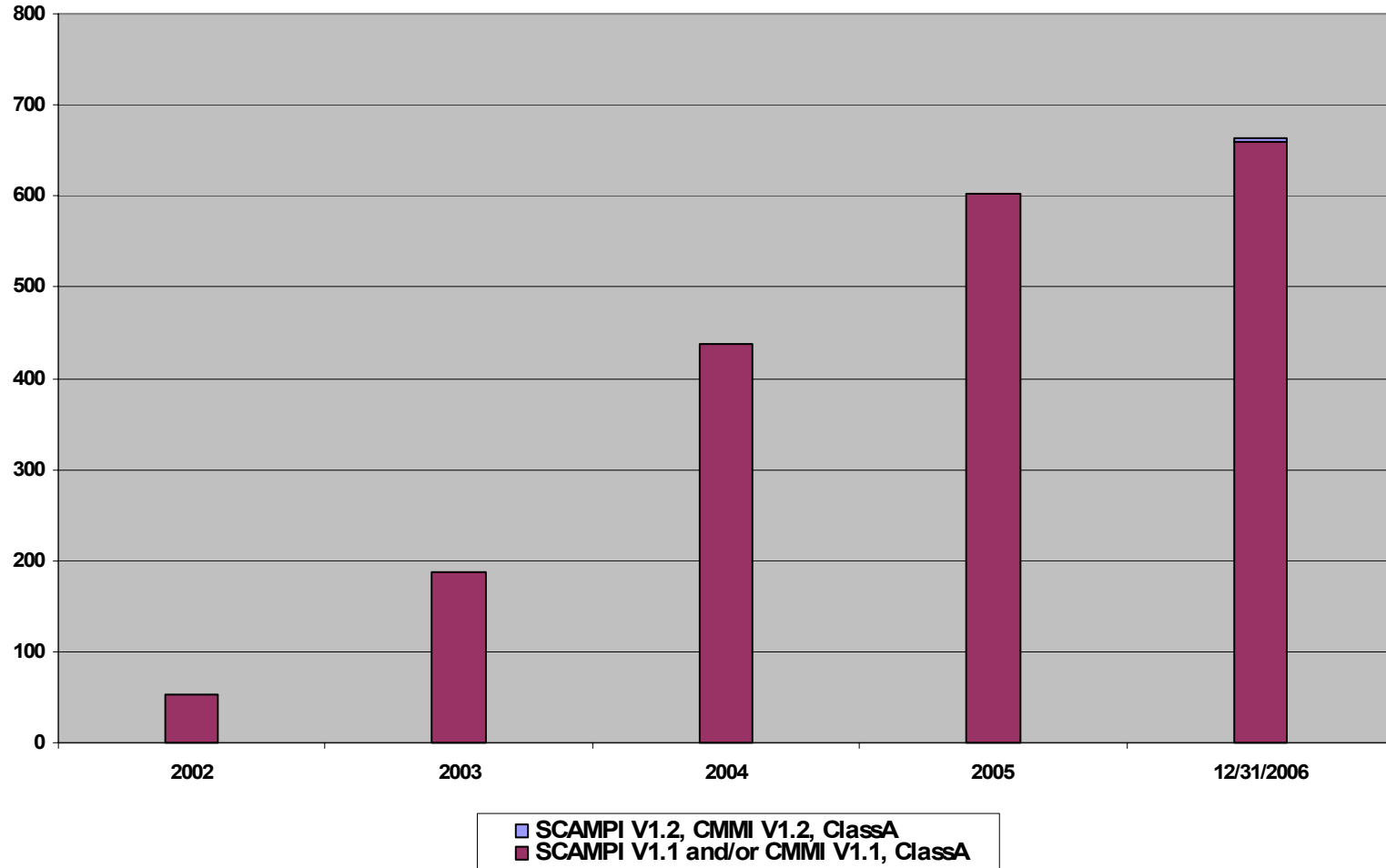



Number of SCAMPI vX Class A Appraisals Conducted by Year by Representation*

Reported as of 31 December 2006

*Where Representation is reported

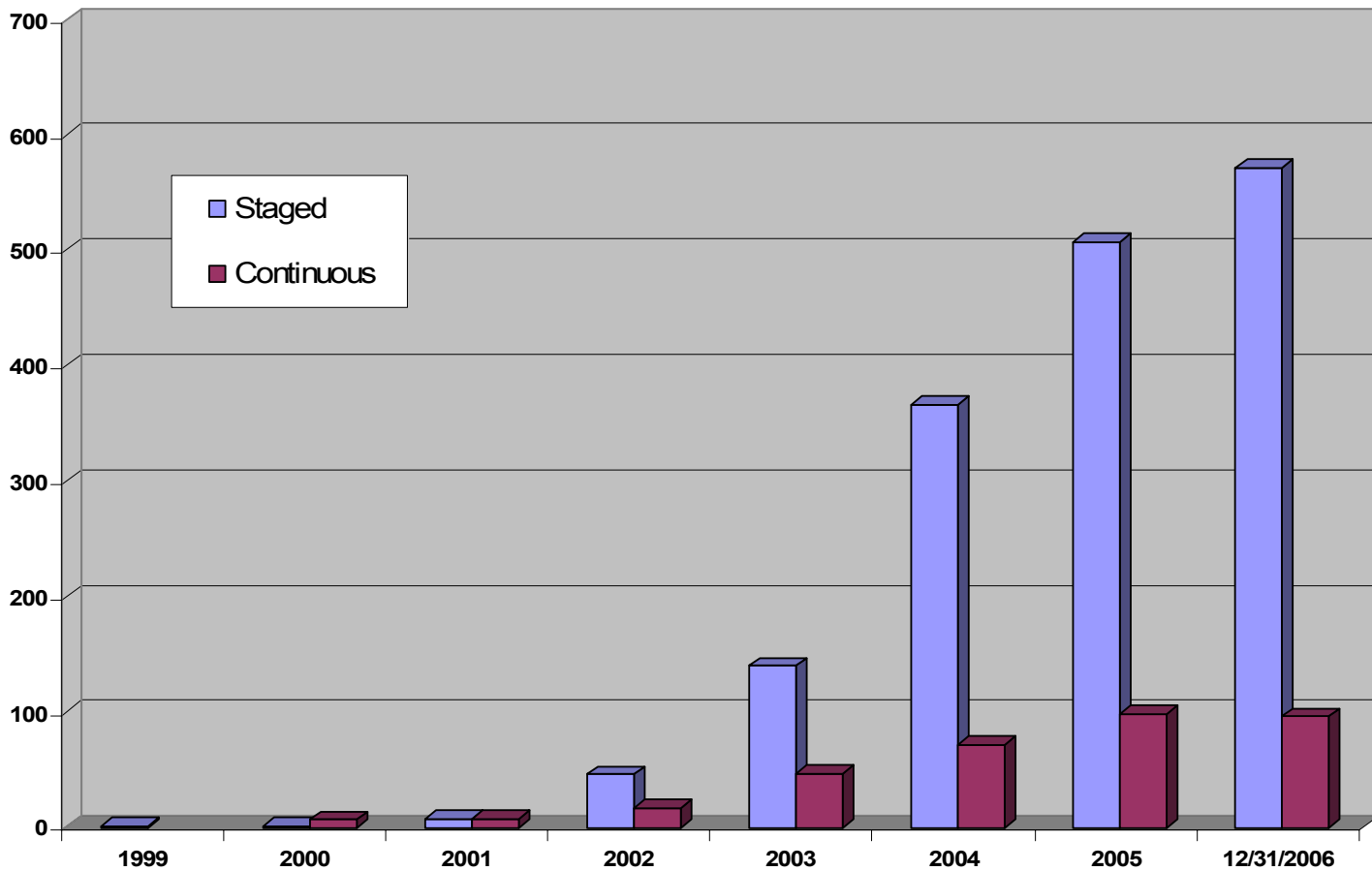

Reporting Organizational Categories

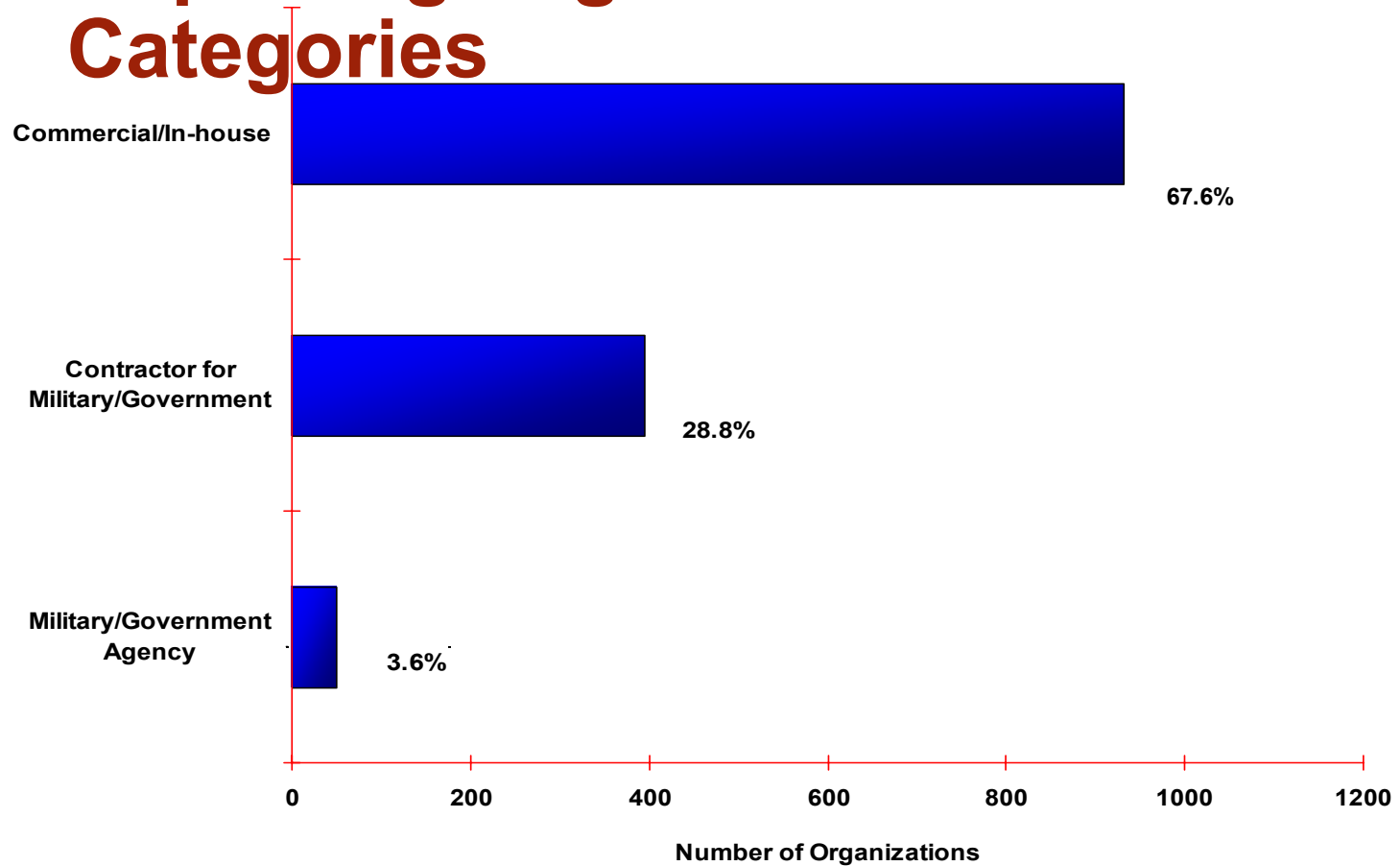

Based on 1,377 organizations



Organization Size

Based on the total number of employees within the area of the organization that was appraised

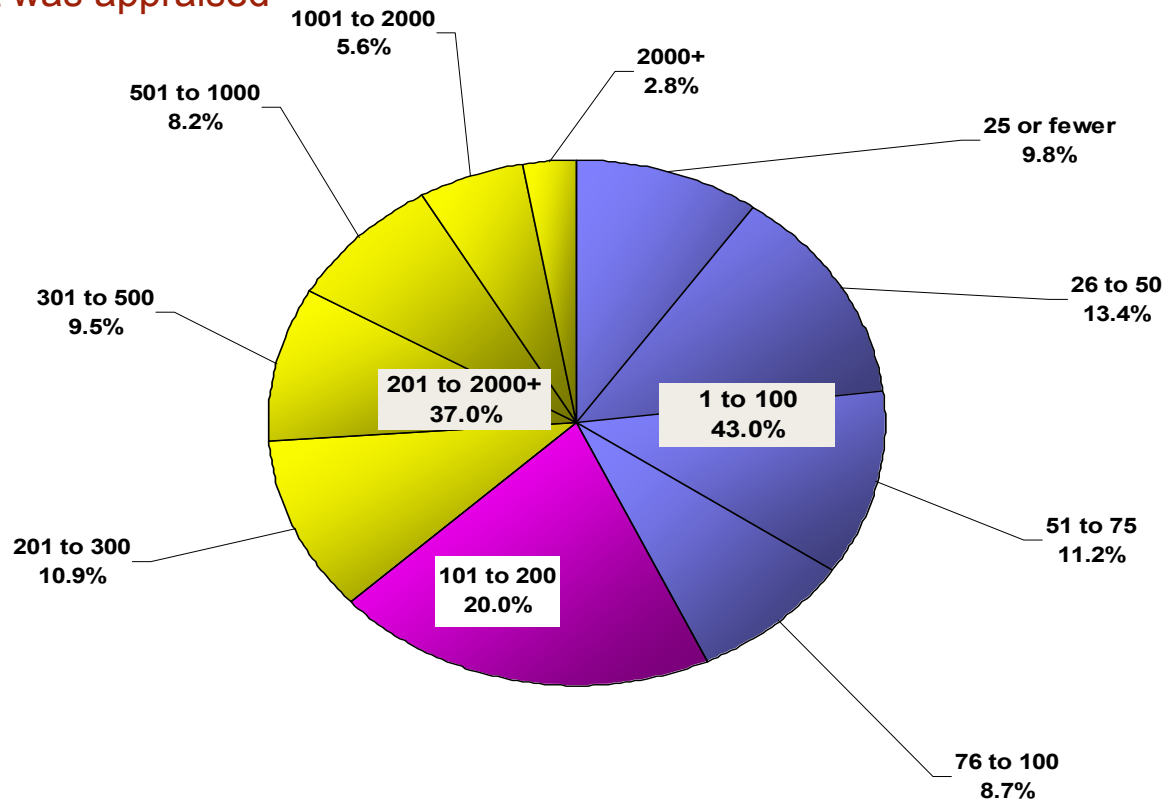

Based on 1,348 organizations reporting size data

Reporting Organizational Types

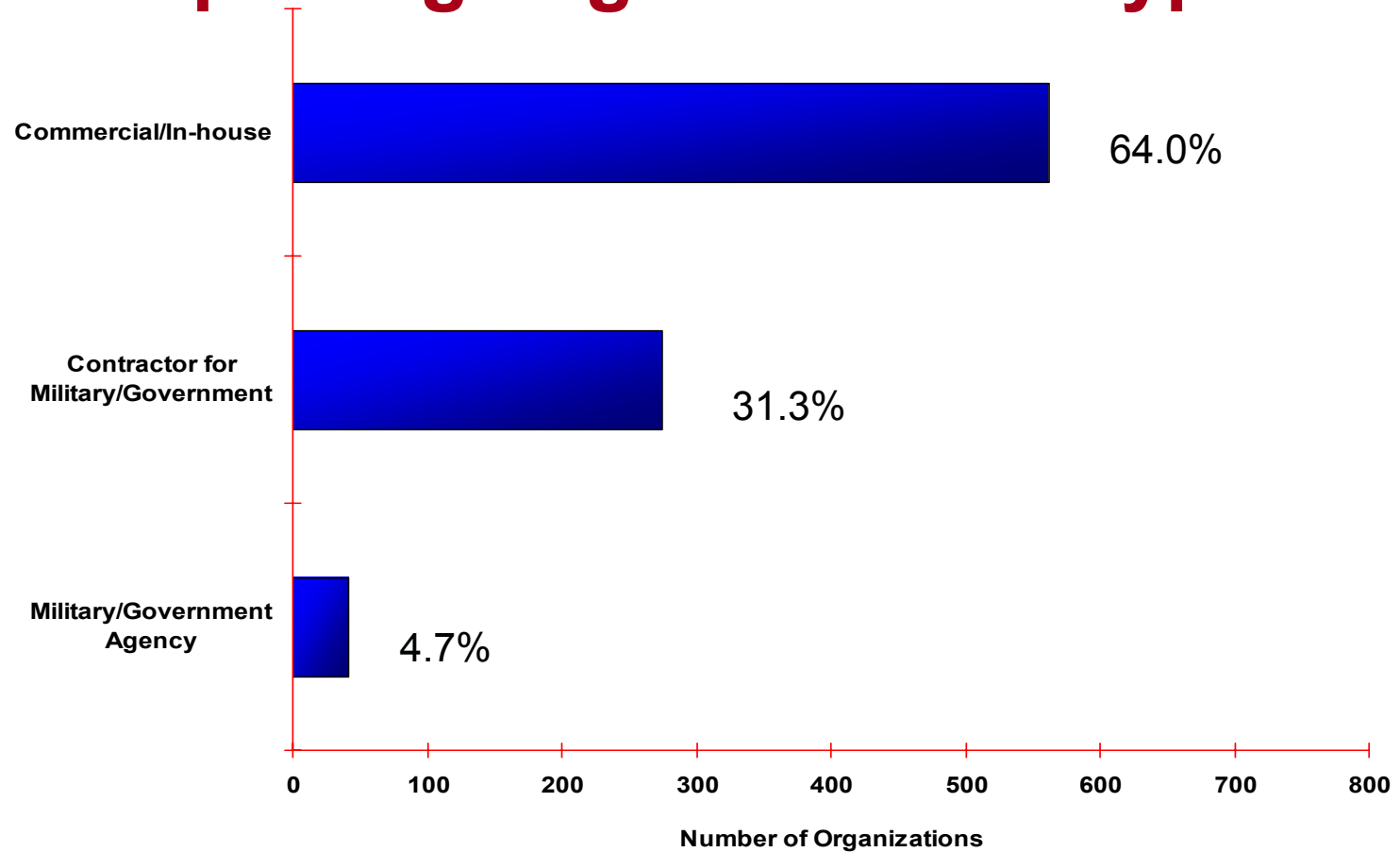

Based on 878 organizations

9/30/05



Maturity Profile by All Reporting USA and Non-USA Organizations

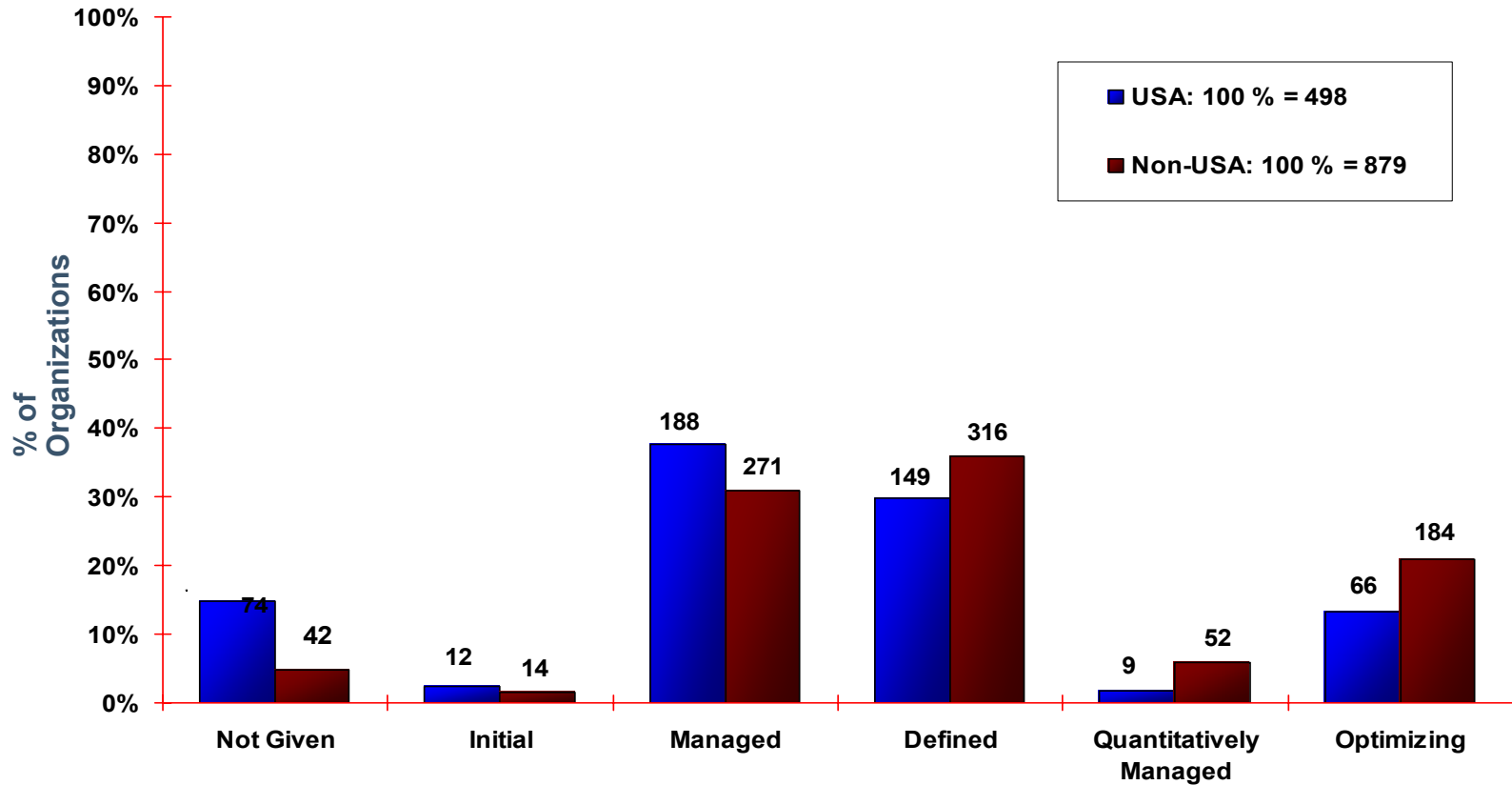

Based on **498** USA organizations and **879** Non-USA organizations



Countries where Appraisals have been Performed and Reported

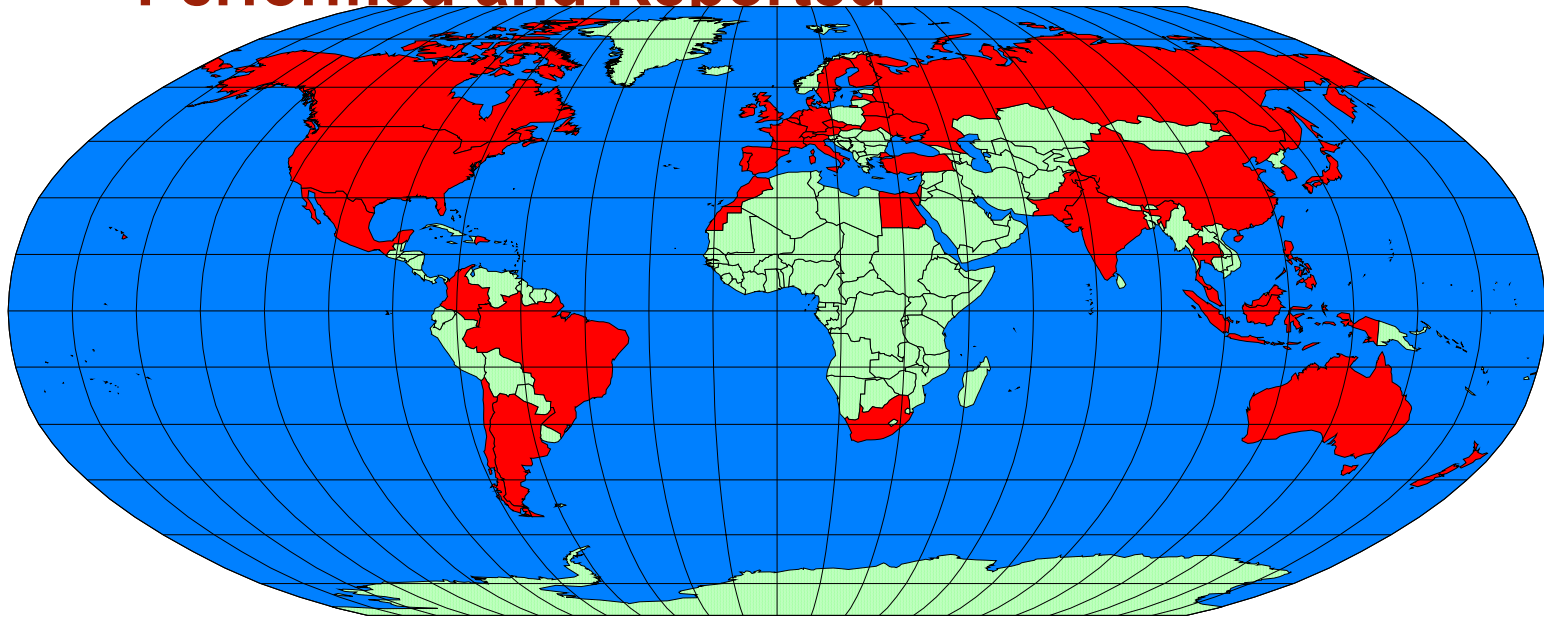

Argentina	Australia	Austria	Bahrain	Belarus	Belgium	Brazil	Canada
Chile	China	Colombia	Czech Republic	Denmark	Dominican Republic	Egypt	Finland
France	Germany	Hong Kong	India	Indonesia	Ireland	Israel	Italy
Japan	Korea, Republic of	Latvia	Malaysia	Mauritius	Mexico	Morocco	Netherlands
New Zealand	Pakistan	Philippines	Portugal	Russia	Singapore	Slovakia	South Africa
Spain	Sweden	Switzerland	Taiwan	Thailand	Turkey	Ukraine	United Kingdom
United States	Vietnam						

Red country name: New additions with this reporting



Number of Appraisals and Maturity Levels Reported to the SEI by Country

Country	Number of Appraisals	Maturity Level 1 Reported	Maturity Level 2 Reported	Maturity Level 3 Reported	Maturity Level 4 Reported	Maturity Level 5 Reported	Country	Number of Appraisals	Maturity Level 1 Reported	Maturity Level 2 Reported	Maturity Level 3 Reported	Maturity Level 4 Reported	Maturity Level 5 Reported
Argentina	15	No	Yes	Yes	Yes	Yes	Korea, Republic of	56	Yes	Yes	Yes	Yes	Yes
Australia	23	Yes	Yes	Yes	Yes	Yes	Latvia	10 or fewer					
Austria	10 or fewer						Malaysia	15	No	No	Yes	No	Yes
Bahrain	10 or fewer						Mauritius	10 or fewer					
Belarus	10 or fewer						Mexico	10 or fewer					
Belgium	10 or fewer						Morocco	10 or fewer					
Brazil	39	No	Yes	Yes	Yes	Yes	Netherlands	10 or fewer					
Canada	18	No	Yes	Yes	No	Yes	New Zealand	10 or fewer					
Chile	10 or fewer						Pakistan	10 or fewer					
China	158	Yes	Yes	Yes	Yes	Yes	Philippines	14	No	Yes	Yes	No	Yes
Colombia	10 or fewer						Portugal	10 or fewer					
Czech Republic	10 or fewer						Russia	10 or fewer					
Denmark	10 or fewer						Singapore	10 or fewer					
Dominican Republic	10 or fewer						Slovakia	10 or fewer					
Egypt	10						South Africa	10 or fewer					
Finland	10 or fewer						Spain	25	No	Yes	Yes	No	Yes
France	65	Yes	Yes	Yes	Yes	Yes	Sweden	10 or fewer					
Germany	28	Yes	Yes	Yes	Yes	Yes	Switzerland	10 or fewer					
Hong Kong	10 or fewer						Taiwan	31	No	Yes	Yes	No	No
India	177	No	Yes	Yes	Yes	Yes	Thailand	10 or fewer					
Indonesia	10 or fewer						Turkey	10 or fewer					
Ireland	10 or fewer						Ukraine	10 or fewer					
Israel	10 or fewer						United Kingdom	42	Yes	Yes	Yes	Yes	No
Italy	10 or fewer						United States	598	Yes	Yes	Yes	Yes	Yes
Japan	155	Yes	Yes	Yes	Yes	Yes	Vietnam	10 or fewer					



Disciplines Selected for Appraisals

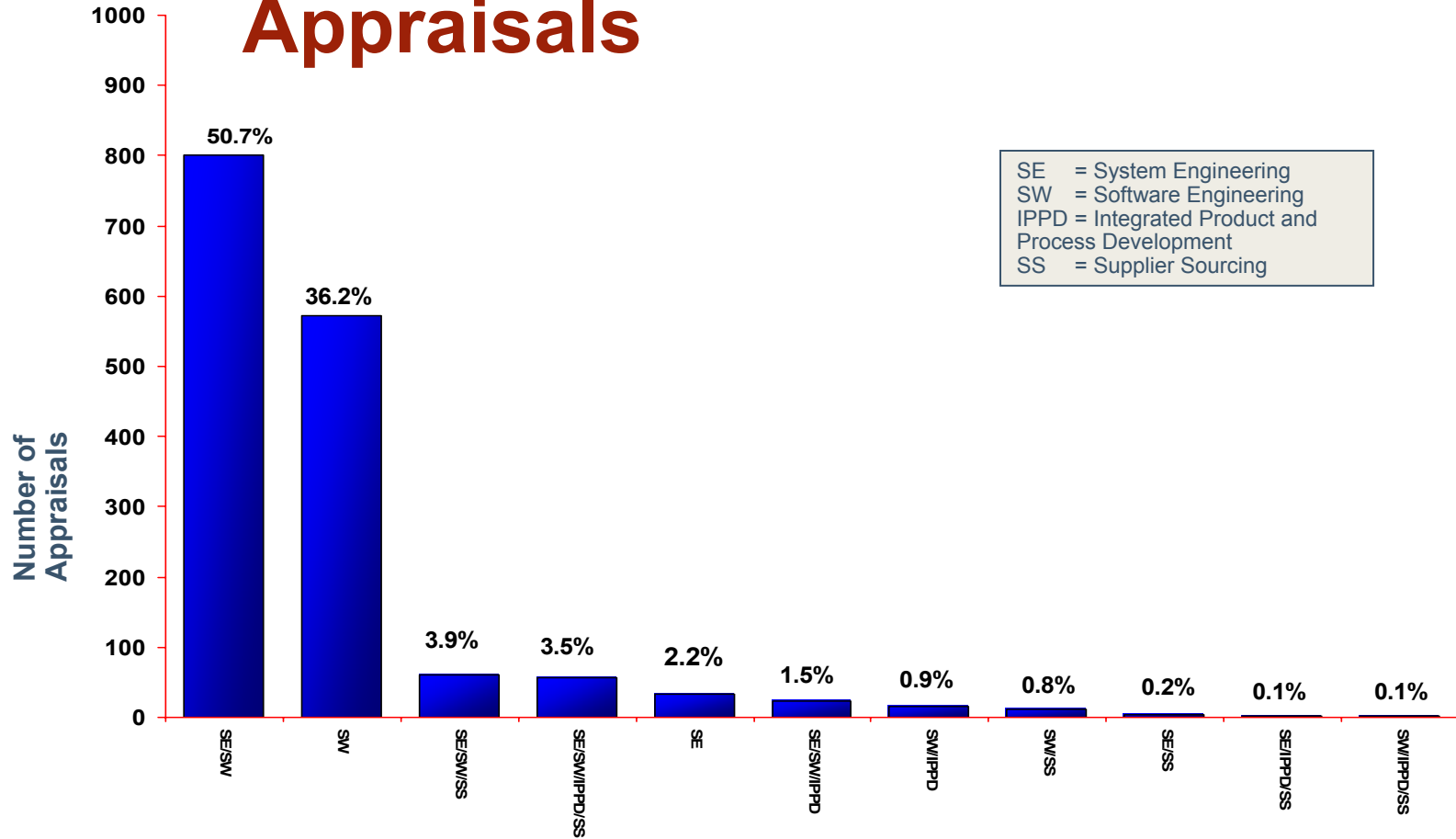

SE = System Engineering
SW = Software Engineering
IPPD = Integrated Product and Process Development
SS = Supplier Sourcing

Based on **1,581** appraisals

For more information about Allowable Models & Combinations, visit: <http://www.sei.cmu.edu/cmml/background/aspec.html>

Combined Appraisal Opportunities

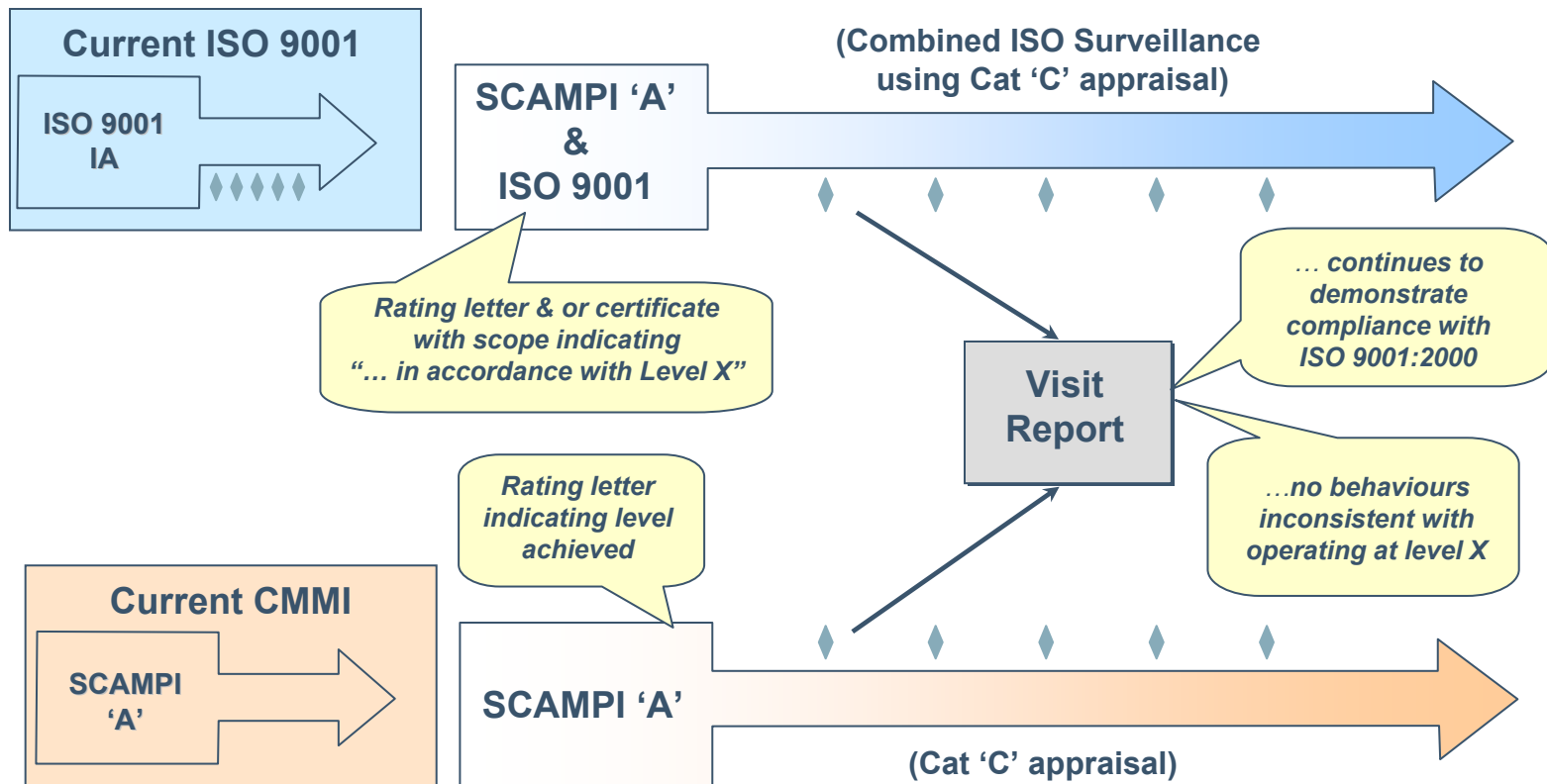

The possible options for assessment and surveillance



Adoption: What Else Is Happening?

The Addison-Wesley SEI Series Book and:

- A Guide to the CMMI
- CMMI: A Framework...
- CMMI Assessments
- CMMI Distilled: Second Edition
- CMMI SCAMPI Distilled
- CMMI Survival Guide
- CMMI: Un Itinéraire Fléché
- De kleine CMMI
- Interpreting the CMMI
- Making Process Improvement Work
- Practical Insight into CMMI
- Real Process Improvement Using the CMMI
- Systematic Process Improvement Using ISO 9001:2000 and CMMI
- Balancing Agility and Discipline

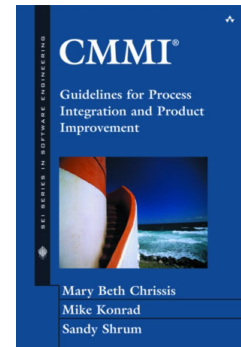



How about SEI Publications?

Technical notes and special reports:

- Using CMMI-DEV for sourcing
- Interpreting CMMI:
 - for Operational Organizations
 - for COTS Based Systems
 - for Service Organizations
 - for Marketing
- Using CMMI with:
 - Earned Value Management
 - Product Line Practices
 - Six Sigma
- Supplementing CMMI for Safety Critical Development
- Demonstrating the Impact and Benefits of CMMI (and web pages – www.sei.cmu.edu/cmml/results)



Performance Results Summary

Improvements	Median	# of data points	Low	High
Cost	34%	29	3%	87%
Schedule	50%	22	2%	95%
Productivity	61%	20	11%	329%
Quality	48%	34	2%	132%
Customer Satisfaction	14%	7	-4%	55%
Return on Investment	4.0 : 1	22	1.7 : 1	27.7 : 1

- N = 30, as of August 2006
- Organizations with results expressed as change over time



CMMI Today

Version 1.1 CMMI Product Suite was released January 2002.

- **CMMI Web site visits average over 12,000/day**
- **Over 58,000 people have been trained**
- **Almost 1600 “class A” appraisals have been reported to the SEI**

Now we want to continuously improve...



CMMI V1.2...and Beyond



Major Themes

Reduce complexity & size

Increase coverage

Increase confidence in appraisal results



Reduced Model Complexity & Size

Eliminated the concepts of **advanced practices** and **common features**

Incorporated **ISM into SAM**; eliminated **Supplier Sourcing (SS)** addition

Consolidated and simplified the **IPPD material**

All definitions consolidated in the glossary

Adopted a **single book approach** (i.e., will no longer provide separate development models)

Report size reduced 15% from either predecessor; PAs reduced 12%



Increased Model Coverage

Added **hardware amplifications**

Added two **work environment practices** (i.e., one in OPD and one in IPM)

Added goal and two practices in OPF to emphasize importance of **project startup**

Updated notes (including examples) where appropriate so that they also address **service development** and **acquisition of critical elements**

Updated name to **CMMI for Development** (CMMI-DEV) to reflect the expanded coverage



Model Changes - Other

Improved the **Overview** section (Part One)

Improved clarity of how GPs are used

- Moved generic goals and practices to Part Two
- Added explanation of how process areas support the implementation of GPs
- Added GP elaborations for GP 3.2

Improved the **glossary** (e.g., higher level management, bidirectional traceability, subprocess)

Limited the process areas that can be considered “**not applicable**” to SAM.

Clarified material throughout the model based on over 1000 change requests



Integrated Product and Process Development (IPPD) Changes

IPPD material is being revised significantly.

- Organization Environment for Integration PA removed and material moved to Organizational Process Definition (OPD) PA.
- Integrated Teaming PA removed and material moved to Integrated Project Management (IPM) PA.
- IPPD goals have been consolidated.
 - “Enable IPPD Management” in OPD
 - “Apply IPPD Principles” in IPM
- Overall material condensed and revised to be more consistent with other PAs.

CMMI Model Combinations

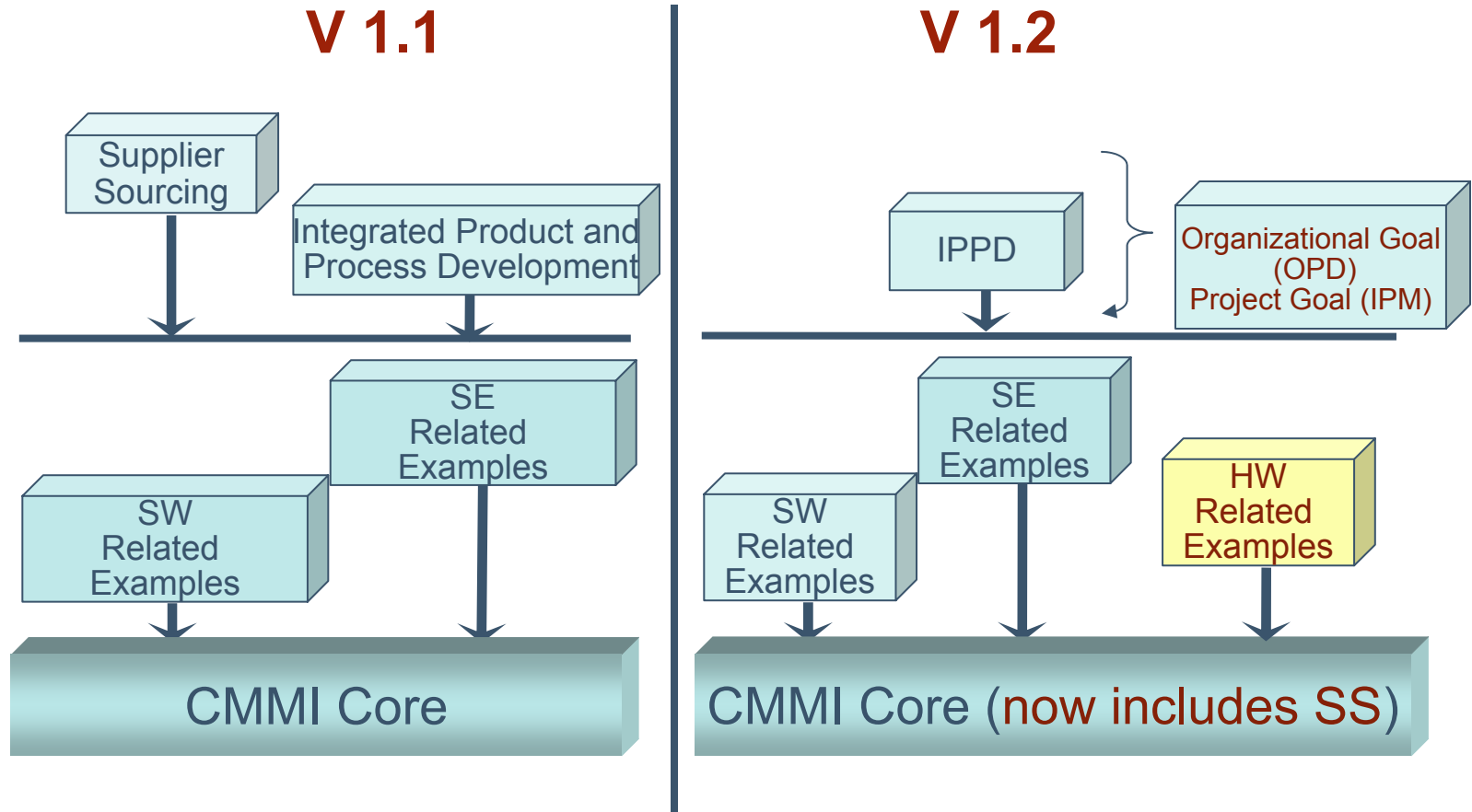



IPPD Changes

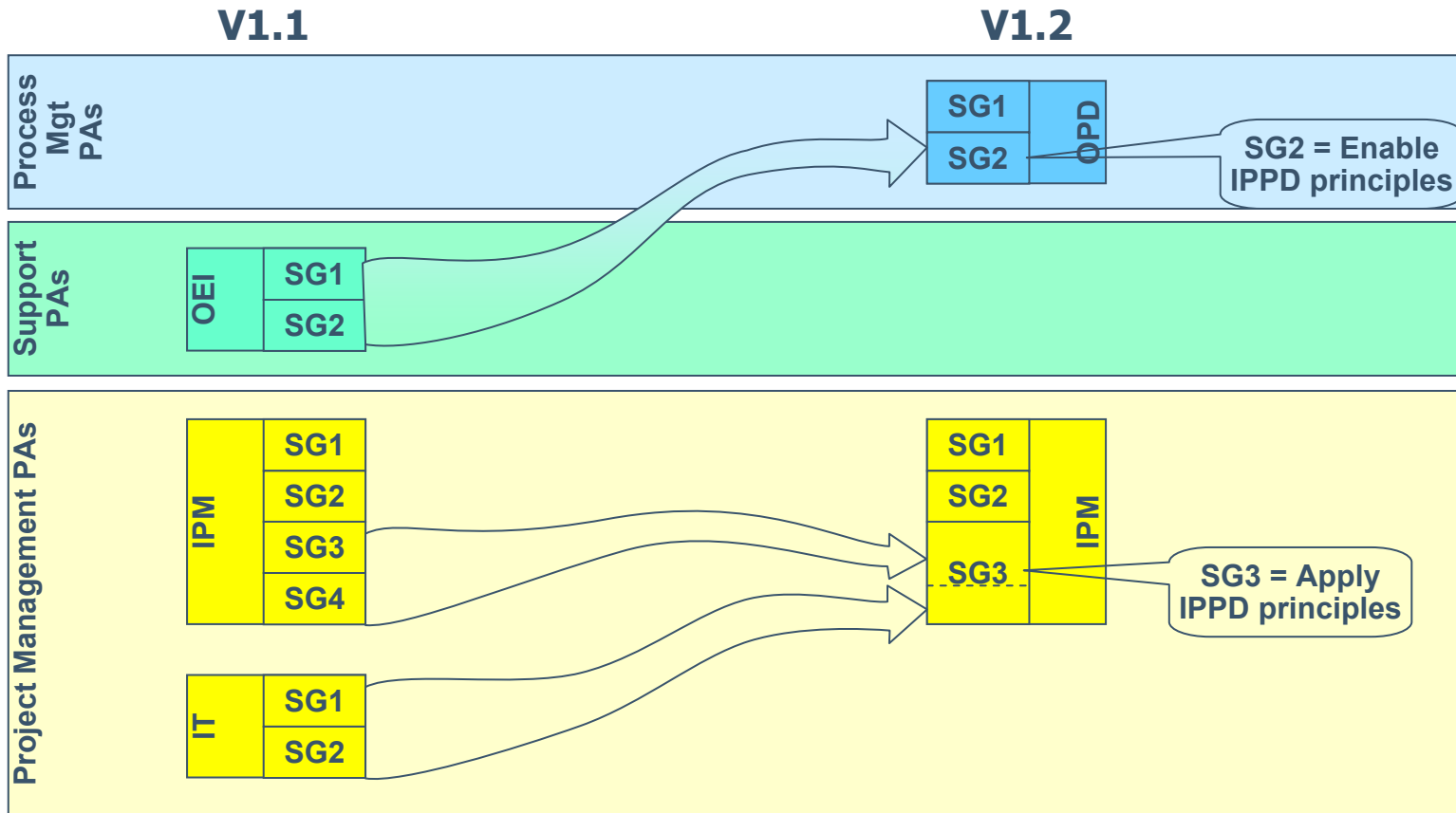



Supplier Agreement Management

Specific Goal

Specific Practice

Establish Supplier Agreements

- 1.1 – Determine Acquisition Type
- 1.2 – Select Suppliers
- 1.3 – Establish Supplier Agreements

Satisfy Supplier Agreements

- 2.1 – Execute the Supplier Agreement
- 2.2 – Monitor Selected Supplier Processes
- 2.3 – Evaluate Selected Supplier Work Products
- 2.4 – Accept the Acquired Product
- 2.5 – Transition Products

v1.1 SP2.1 “Review COTS Products,” was eliminated. “Identify candidate COTS products that satisfy requirements” is a new subpractice under the Technical Solutions Process Area SP1.1, “Develop Alternative Solutions and Selection Criteria.”



Organizational Process Focus

V1.1

SG1 – Determine Process Improvement Opportunities

- 1.1 – Establish Organizational Process Needs
- 1.2 – Appraise the Organization’s Processes
- 1.3 – Identify the Organization’s Process Improvements

SG2 – Plan and Implement Process Improvement Activities

- 2.1 – Establish Process Action Plans
- 2.2 – Implement Process Action Plans
- 2.3 – Deploy Organizational Process Assets
- 2.4 – Incorporate Process-Related Experiences into the Organizational Process Assets

V1.2

SG1 – Determine Process Improvement Opportunities

- 1.1 – Establish Organizational Process Needs
- 1.2 – Appraise the Organization’s Processes
- 1.3 – Identify the Organization’s Process Improvements

SG2 – Plan and Implement Process Improvement

- 2.1 – Establish Process Action Plans
- 2.2 – Implement Process Action Plans

New

SG3 – Deploy Organizational Process Assets and Incorporate Lessons Learned

- 3.1 – Deploy Organizational Process Assets
 - 3.2 -- Deploy Standard Processes
 - 3.3 -- Monitor Implementation
 - 3.4 -- Incorporate Process Related Experiences into the Organizational Process Assets
-



SCAMPI A Changes for V1.2

Method implementation clarifications

- interviews in “virtual” organizations
- practice characterization rules
- organizational unit sampling options

Appraisal Disclosure Statement (ADS) improvements

- reduce redundancy with other appraisal documents
- improve usability for sponsor and government
- Level 4,5 mapping to business objectives
- require sponsor’s signature on the ADS
- require all team members to show agreement on findings
- Both V1,1 and V1.2 ADS reflect these today

Appraisal team will have responsibility for determination of “applicability” for SAM

Maturity level and capability level shelf life – 3 years, given 1 year of V1.2 availability

Published Appraisal Results

List of Published SCAMPI Appraisal Results

ORGANIZATION NAME: Satyam Computer Services Ltd.
SPONSOR NAME: Nagaraj Chevour
LEAD APPRAISER NAME: Raghavan Nandyal
SEI PARTNER: SITARA Technologies Pvt. Ltd.
APPRAISAL END DATE: 4/3/2004
MATURITY LEVEL ASSIGNED: 5
APPRAISED ORGANIZATIONAL UNIT:
 Entity Name: SRU GE-GDC
 Location(s): Secunderabad, AP, India
CMMI MODEL USED: CMMI-SW/PPD, V1.1, Continuous
APPRAISAL METHOD USED: SCAMPI v1.1

MODEL SCOPE & CAPABILITY RATINGS ASSIGNED:

Process Management	Project Management	Engineering	Support
OPF Capability Level 3	PP Capability Level 4	REQM Capability Level 3	CM Capability Level 3
OPD Capability Level 3	PMC Capability Level 4	RD Capability Level 4	PPQA Capability Level 3
OT Capability Level 3	SAM Not Applicable	TS Capability Level 5	MA Capability Level 3
OPP Capability Level 3	IPM Capability Level 3	PI Capability Level 3	DAR Capability Level 3
OID Capability Level 3	RSKM Capability Level 4	VER Capability Level 5	OEI Capability Level 3
	IT Capability Level 3	VAL Capability Level 3	CAR Capability Level 3
	ISM Not Rated		
	QPM Capability Level 3		



CMMI Training v1.2

Introduction to CMMI (Staged and Continuous)

- Editorial update released 9/05
- Updated v1.2 phased in this fall

Intermediate Concepts of CMMI

- Being updated for v1.2
- will better prepare students for SCAMPI training

CMMI Instructor Training

- Being updated to reflect v1.2 changes

“Delta” training from V1.1 to V1.2

- Available on-line for free
- More extensive upgrade course for fee
 - Appraisal Team members
 - Lead Appraisers, Instructors, candidates



CMMI V1.2 Schedules

Version 1.2 CMMI Product Suite release	August 25, 2006
V1.2 ADS required for all SCAMPs	November, 2006
Last V1.1 Intro training	December, 2006
First expiration of V1.1 appraisals (3 year validity)	August 25, 2007
Last V1.1 appraisal	August 31, 2007
Full Certification for Lead Appraisers begins	October, 2007



Beyond V1.2₁

Improved architecture will allow post-V1.2 expansion.

- Extensions of the life cycle (Services, Outsourcing/Acquisition) could expand use of a common organizational framework:
 - allows coverage of more of the enterprise or potential partnering organizations
 - adapts model features to fit non-developmental efforts (e.g., CMMI Services, CMMI Acquisition)

Three Complementary Constellations

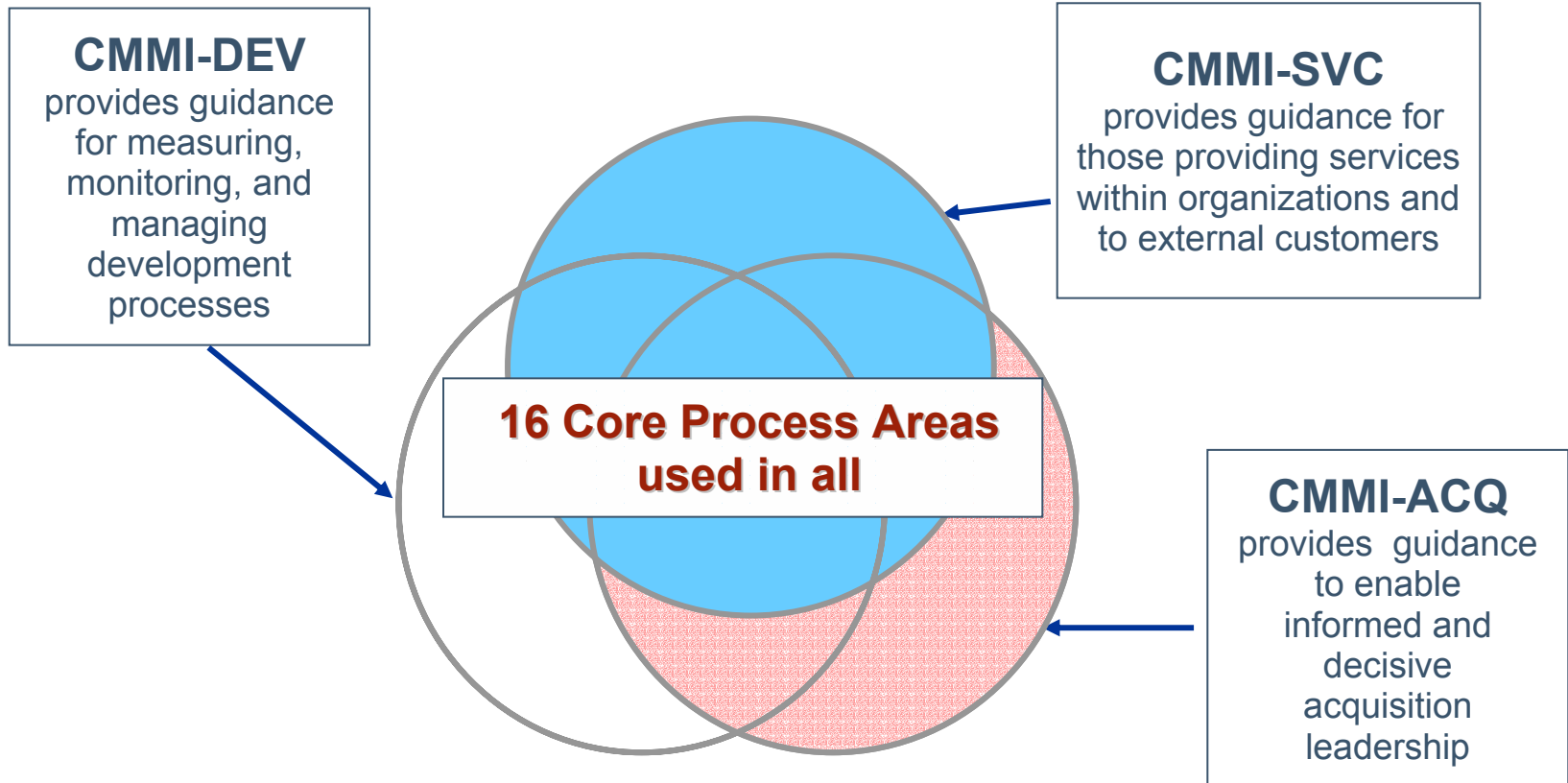



Architecture & Constellations

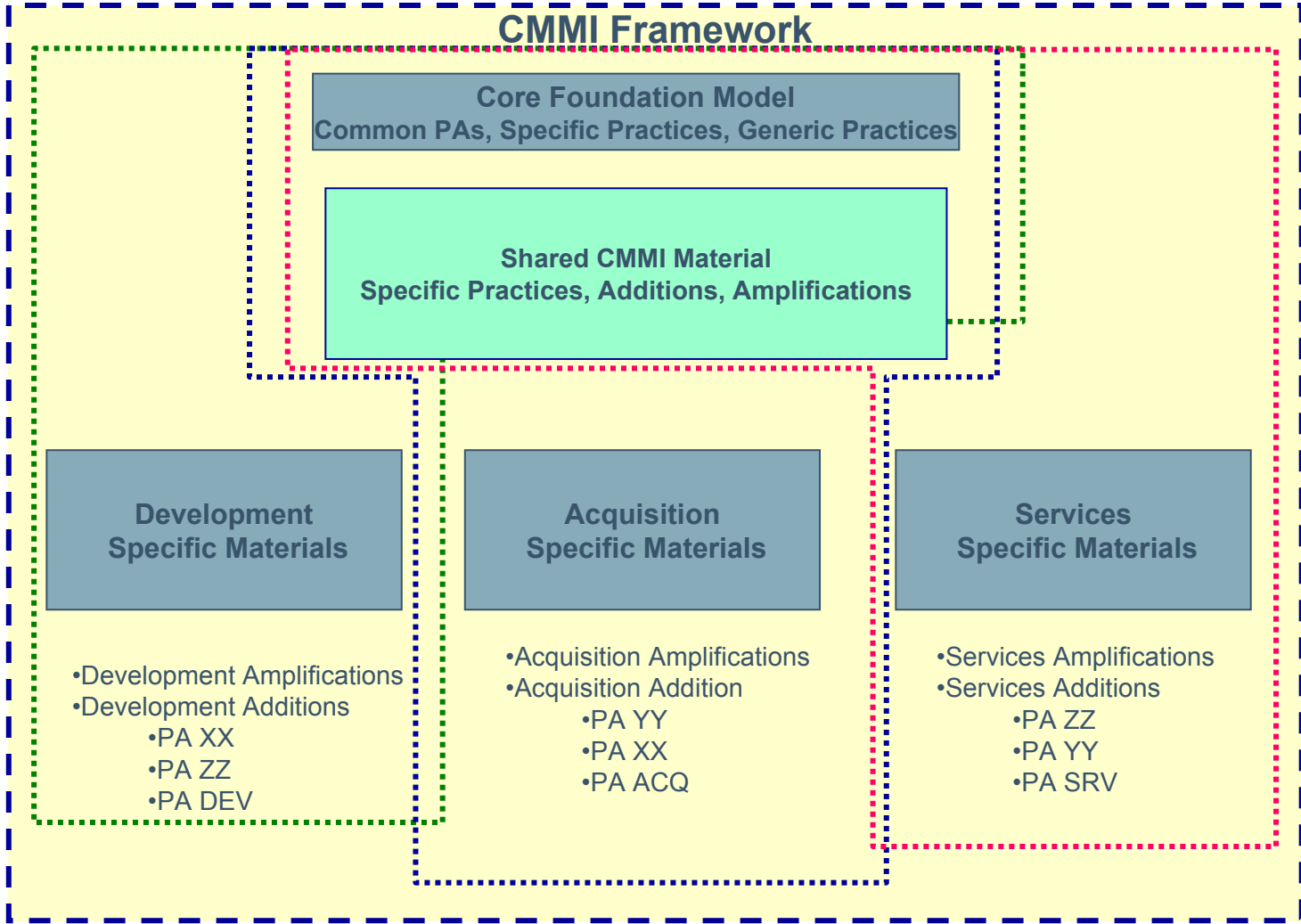



Beyond V1.2₂

First two new “constellations,” CMMI for Services and CMMI for Acquisition, have been “commissioned” by CMMI Steering Group. Development will be in parallel with V1.2 effort; publication sequenced after V1.2 rollout.

Northrop-Grumman is leading industry group for CMMI Services.

- Initial focus will be for organizations providing “DoD services” as well as internal IT:
 - System maintenance
 - Network Management, IT Services
 - IV&V



Beyond V1.2₃

SEI is coordinating development of CMMI-ACQ.

- Built upon draft created with General Motors for IT Sourcing
- Adds government acquisition perspectives from both DoD and civil agencies
 - Recognizes importance of acquisition requirements development (moved to level 2)
 - Adds perspectives for multiple suppliers to address systems of systems, customer agreements

Initial CMMI-ACQ Key Acquisition Processes*

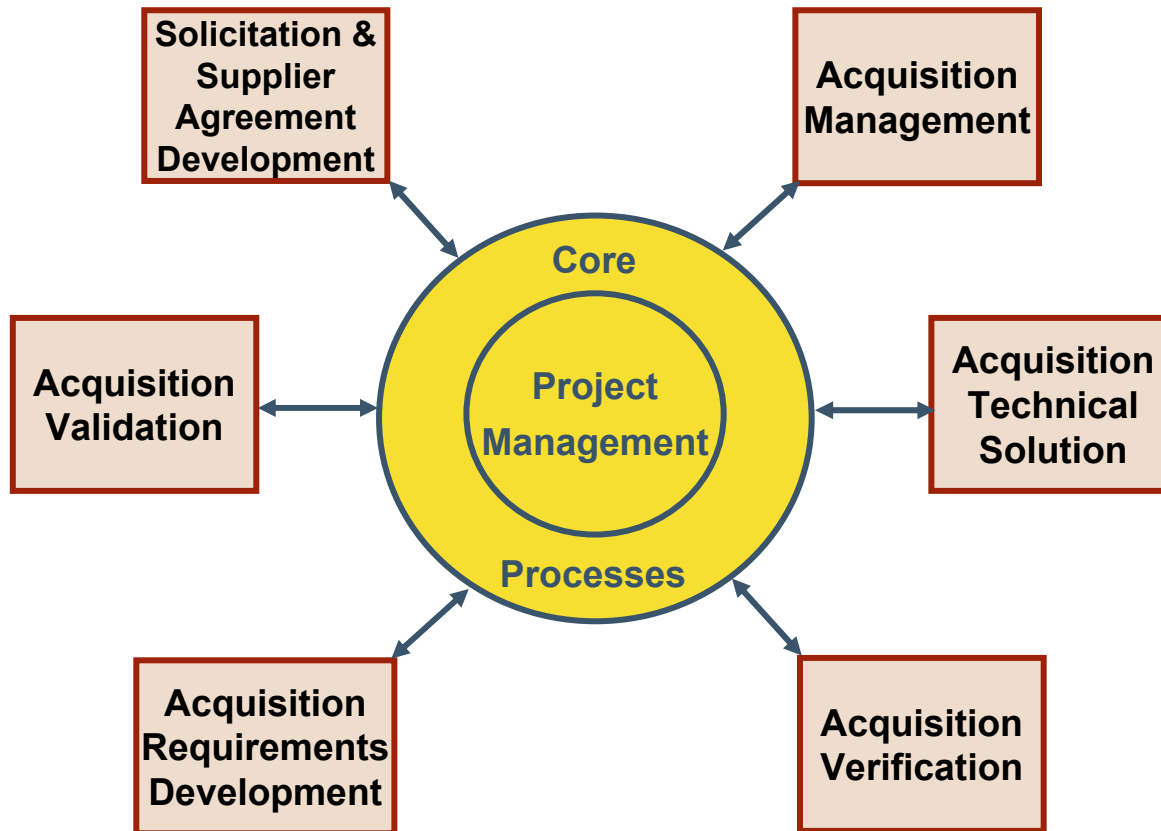

Planned Sequence of Models

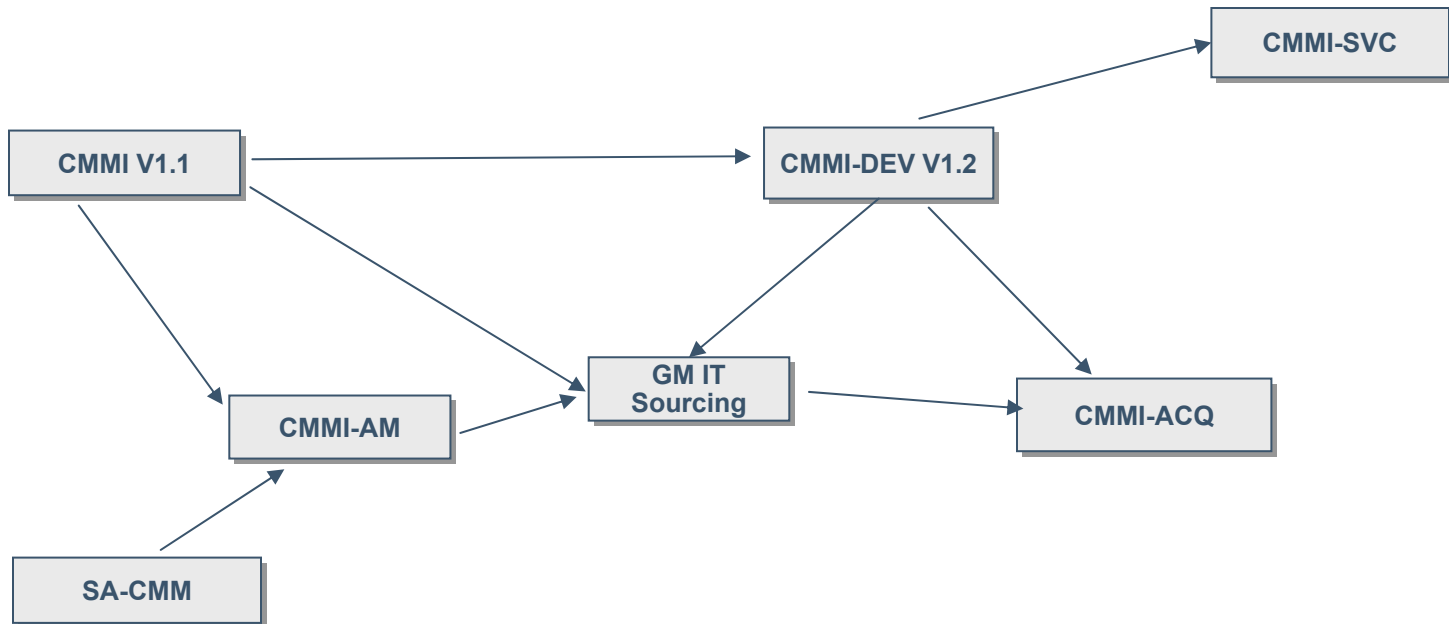



CMMI V1.2...and Beyond ...the details

Model Changes

Model Structure¹

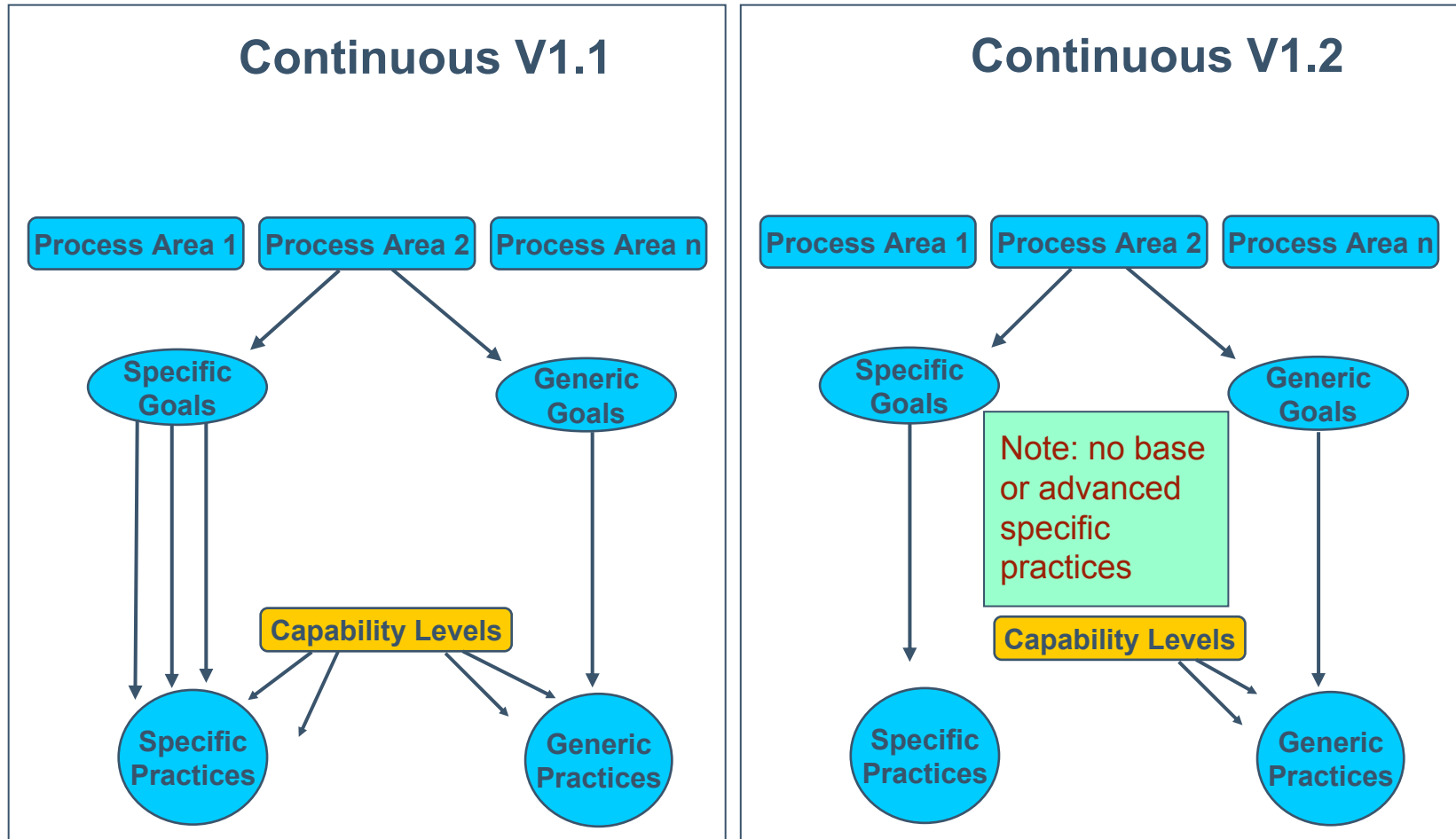



Model Structure²

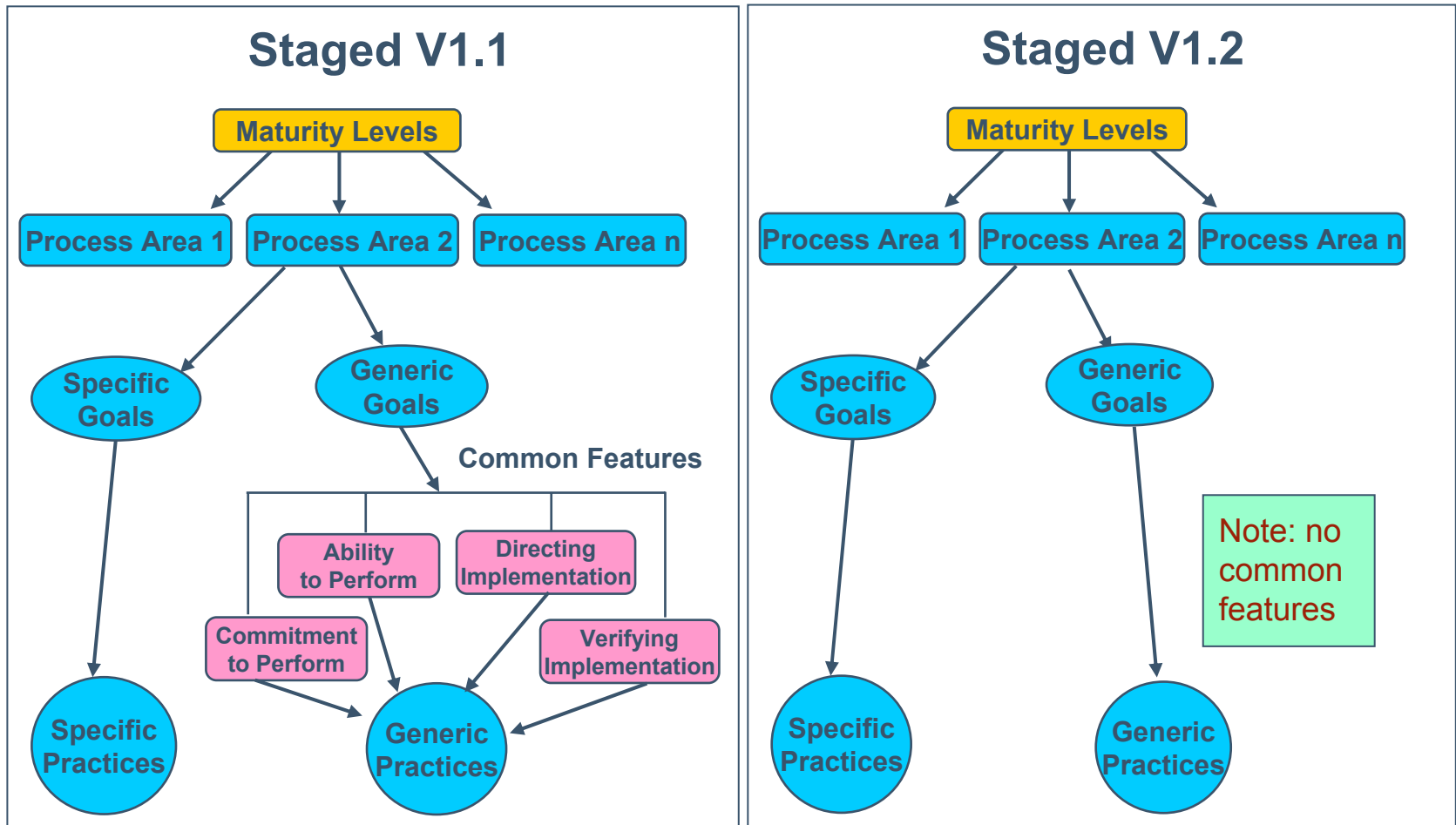



The Model Is a Single Document

All representations, additions, and disciplines are in one document.

Users can choose to use:

- representation-specific content (i.e., continuous, staged)
- addition-specific content (i.e., IPPD)
- amplifications (i.e., hardware engineering, software engineering, systems engineering)



Added Hardware Amplifications and Examples

Six hardware amplifications were created to add emphasis on hardware engineering. Here is an example from TS.

SP 2.1 Design the Product or Product Component

Develop a design for the product or product component.

For Hardware Engineering

Detailed design is focused on product development of electronic, mechanical, electro-optical, and other hardware products and their components. Electrical schematics and interconnection diagrams are developed, mechanical and optical assembly models are generated, and fabrication and assembly processes are developed.

Hardware examples were also added to emphasize hardware engineering.



Added Work Environment Coverage

Work environment standards are established at the organizational level in OPD.

SP 1.6 Establish Work Environment Standards

Establish and maintain work environment standards.

The project's work environment is established at the project level in IPM.

SP 1.3 Establish the Project's Work Environment

Establish and maintain the project's work environment based on the organization's work environment standards.



Overview Section Improvements

The following improvements were made to the model overview (i.e., Part One):

- The chapter containing the generic goals and practices was moved to Part Two with the process areas.
- All definitions are consolidated into the glossary.
- Chapters were reordered into a more logical sequence.
- The **Preface** and **Using CMMI Models** chapter were rewritten and updated.
- Descriptions were updated to reflect the new CMMI architecture:
 - Added descriptions of **constellations** and **additions**
 - Removed descriptions of base and advanced practices and common features



Improved Generic Practices¹

Editorial changes were made to the generic practices. These slides highlight the changes that affect the content.

GP 1.1: Perform Specific Practices

The practice title and statement changed from “perform **base** practices” to “perform **specific** practices.”

GP 2.2: Plan the Process

The informative material was **condensed** to be consistent with the other generic practices.

GP 2.4: Assign Responsibility

In the informative material “and **authority**” was added.



Improved Generic Practices²

GP 2.6: Manage Configurations

In the GP statement, “levels of configuration management” was changed to “levels of control.”

GP 2.9 Objectively Evaluate Adherence

Added informative material to emphasize work products also.

GP 5.2: Correct Root Causes of Problems

Added notes that the focus of this GP is on a quantitatively managed process, though root causes may be found outside of that process.



Explained Generic Practices Better

Moved generic goals and practices to **Part Two** with the process areas so that all normative elements of the model are consolidated in one place

Added information about how process areas support the implementation of generic practices (GPs)

Added GP elaborations for GP 3.2



“Not Applicable” Process Areas

The set of PAs evaluated to achieve a maturity level is an important variable when conducting an appraisal. In v1.1 it was not clear which PAs could be considered “not applicable.”

In v1.2, the guidance for appraisals exists in both SCAMPISM MDD Appendix A and SCAMPI A Appraisal Disclosure Statement (ADS):

- Only SAM can be declared not applicable.
- Decisions on PAs included in the appraisal must be made by the lead appraiser in conjunction with the appraisal sponsor.
- Rationale for declaring SAM to be “not applicable” must be provided in the Appraisal Disclosure Statement.



Glossary Changes

The following slides contain significant changes to glossary definitions. Definitions that only had editorial changes are not included.

New definitions: addition, amplification, bidirectional traceability, customer requirement, data, functional configuration audit, hardware engineering, higher level management, physical configuration audit, project startup, and service.

Revised definitions: acquisition, appraisal, appraisal findings, appraisal scope, audit, capability evaluation, configuration audit, customer, data management, establish and maintain, generic goal, objective evidence, process element, product, product component, project, quality- and process-performance objectives, requirements traceability, shared vision, subprocess, traceability, and work product.



Definitions Deleted From the Glossary

Deleted definitions: ability to perform, advanced practices, agreement/contract requirements, appraisal tailoring, appraisal team leader, base practices, CMMI model tailoring, commitment to perform, directing implementation, discipline amplification, lead appraiser, process context, solicitation package, strength, verifying implementation, weakness

Many of these definitions were deleted because the term wasn't used in the model or the overall concept was removed.



Process Area Improvements¹

Improvements were made to all process areas; some process areas changed more than others. Only the process areas that were changed significantly will be addressed.

Many of these changes were discussed earlier. However, these slides show you significant changes by process area.



Process Area Improvements²

The following process areas were improved significantly:

- Integrated Project Management +IPPD (IPM+IPPD)
- Organizational Process Definition +IPPD (OPD+IPPD)
- Organizational Process Focus (OPF)
- Requirements Management (REQM)
- Requirements Development (RD)
- Supplier Agreement Management (SAM)
- Technical Solution (TS)
- Validation (VAL)
- Verification (VER)



Integrated Project Management +IPPD¹

Specific Goal

Use the Project's
Defined Process

Specific Practice

1.1 – Establish the Project's Defined Process

1.2 – Use Organizational Process Assets for Planning Project Activities

1.3 – Establish the Project's Work Environment

1.4 – Integrate Plans

1.5 – Manage the Project Using the Integrated Plans

1.6 – Contribute to the Organizational Process Assets

-
- Modified SP 1.1 from “Establish and maintain the project's defined process” to “Establish and maintain the project's defined process from project startup through the life of the project.”
 - Added SP 1.3 “Establish the Project's Work Environment.” (This practice is new to CMMI.)



Integrated Project Management +IPPD²

Specific Goal

Specific Practice

Coordinate and Collaborate with Relevant Stakeholders

- 2.1 – Manage Stakeholder Involvement
- 2.2 – Manage Dependencies
- 2.3 – Resolve Coordination Issues

Apply IPPD Principles

- 3.1 – Establish the Project’s Shared Vision
- 3.2 – Establish the Integrated Team Structure
- 3.3 – Allocate Requirements to Integrated Teams
- 3.4 – Establish Integrated Teams
- 3.5 – Ensure Collaboration among Interfacing Teams

- Reduced the IPPD Addition to one goal (SG3 “Apply IPPD Principles”) and its practices.
- To emphasize the IPPD Addition, the name of this process area is now “Integrated Project Management +IPPD” or “IPM +IPPD.”



Organizational Process Definition +IPPD¹

Specific Goal

Specific Practice

Establish Organizational
Process Assets

1.1 – Establish Standard Processes

1.2 – Establish Lifecycle Model
Descriptions

1.3 – Establish Tailoring Criteria and
Guidelines

1.4 – Establish the Organization’s
Measurement Repository

1.5 – Establish the Organization’s Process
Asset Library

**1.6 – Establish Work Environment
Standards**

- Added “and work environment standards” to the purpose statement.
- Added SP 1.6 “Establish Work Environment Standards.” (This practice is new to CMMI.)



Organizational Process Definition **+IPPD²**

Specific Goal

Specific Practice

Enable IPPD Management

2.1 – Establish Empowerment Mechanisms

2.2 – Establish Rules and Guidelines for Integrated Teams

2.3 – Balance Team and Home Organization Responsibilities

- Added an IPPD Addition to OPD (SG2 “Enable IPPD Management” and its practices).
- To emphasize the IPPD Addition, the name the process area is now “Organizational Process Definition +IPPD” or “OPD +IPPD.”



Organizational Process Focus¹

Specific Goal

Determine Process
Improvement
Opportunities

Specific Practice

1.1 – Establish Organizational Process
Needs

1.2 – Appraise the Organization's
Processes

1.3 – Identify the Organization's
Process Improvements

- Modified the purpose statement to emphasize deployment.
- SP 1.2 “Appraise the organization’s processes periodically and as needed to maintain an understanding of their strengths and weaknesses.” uses “organization’s processes” instead of “processes of the organization.”



Organizational Process Focus²

Specific Goal

**Plan and Implement
Process
Improvements**

Specific Practice

**2.1 – Establish Process Action Plans
2.2 – Implement Process Action Plans**

-
- Modified SG2 from “Plan and Implement Process Improvement Activities” to “Plan and Implement Process Improvements.”
 - Moved to a new SG3 and modified what were SP 2.3 and SP 2.4 in v1.1.



Organizational Process Focus³

Specific Goal

Specific Practice

Deploy Organizational Process Assets and Incorporate Lessons Learned

3.1 – Deploy Organizational Process Assets

3.2 – Deploy Standard Processes

3.3 – Monitor Implementation

3.4 – Incorporate Process-Related Experiences into the Organizational Process Assets

- Added new SG3, “Deploy Organizational Process Assets and Incorporate Lessons Learned.”
- Moved what were SP 2.3 and SP 2.4 in v1.1 to the new SG3 as SP 3.1 and SP 3.4.
- Added two new SPs: SP 3.2 “Deploy Standard Processes,” and SP 3.3 “Monitor Implementation.”



Requirements Management

Specific Goal

Specific Practice

Manage Requirements

1.1 – Obtain an Understanding of Requirements

1.2 – Obtain Commitment to Requirements

1.3 – Manage Requirements Changes

1.4 – Maintain Bidirectional Traceability of Requirements

1.5 – Identify Inconsistencies Between Project Work and Requirements

- V1.2 REQM SP 1.4 practice statement now reads, “Maintain bidirectional traceability among the requirements and work products.”
- Project plans are no longer mentioned in this SP statement.
- The description of bidirectional traceability is improved as is its definition in the glossary.



Requirements Development¹

Specific Goal

Specific Practice

Develop Customer Requirements

1.1 – Elicit Needs

1.2 – Develop the Customer Requirements

Develop Product Requirements

2.1 – Establish Product and Product Component Requirements

2.2 – Allocate Product Component Requirements

2.3 – Identify Interface Requirements

-
- Former base practice “Collect Stakeholder Needs” is eliminated and former advanced practice, “Elicit Needs” is kept.
 - Informative text is added to the introductory notes about applying RD to maintenance projects.

Requirements Development²

Specific Goal

Analyze and Validate Requirements

Specific Practice

3.1 – Establish Operational Concepts and Scenarios

3.2 – Establish a Definition of Required Functionality

3.3 – Analyze Requirements

3.4 – Analyze Requirements to Achieve Balance

3.5 – Validate Requirements

- Material from V1.1 TS SP 1.2, “Evolve Operational Concepts and Scenarios,” is incorporated into RD SP 3.1.
- Material from V1.1 RD SP 3.5-1, “Validate Requirements,” and RD SP 3.5-2, “Validate Requirements with Comprehensive Methods” were consolidated into a single practice.



Supplier Agreement Management

Specific Goal

Specific Practice

Establish Supplier Agreements

- 1.1 – Determine Acquisition Type
- 1.2 – Select Suppliers
- 1.3 – Establish Supplier Agreements

Satisfy Supplier Agreements

- 2.1 – Execute the Supplier Agreement
- 2.2 – **Monitor Selected Supplier Processes**
- 2.3 – **Evaluate Selected Supplier Work Products**
- 2.4 – Accept the Acquired Product
- 2.5 – Transition Products

-
- V1.1 SAM SP2.1 “Review COTS Products,” was eliminated. “Identify candidate COTS products that satisfy requirements” is a new subpractice under the Technical Solutions Process Area SP1.1, “Develop Alternative Solutions and Selection Criteria.”
 - SP2.2 and SP2.3 were added because ISM was eliminated.
 - The purpose of SAM was also updated.



Technical Solution¹

Specific Goal

Select Product-
Component Solutions

Specific Practice

1.1 – Develop Alternative Solutions and Selection Criteria

1.2 – Select Product-Component Solutions

- V1.1 TS SP 1.1-1, “Develop Alternative Solutions and Selection Criteria,” and TS SP 1.1-2, “Develop Detailed Alternative Solutions and Selection Criteria” are consolidated into a single practice.
- “Identify candidate COTS products that satisfy requirements” is a new subpractice under SP1.1.
- V1.1 TS SP 1.2 “Evolve Operational Concepts and Scenarios” is incorporated into RD SP 3.1, “Establish Operational Concepts and Scenarios.”



Technical Solution²

Specific Goal

Develop the Design

Specific Practice

2.1 – Design the Product or Product Component

2.2 – Establish a Technical Data Package

2.3 – Design Interfaces Using Criteria

2.4 – Perform Make, Buy, or Reuse Analyses

Implement the Product Design

3.1 – Implement the Design

3.2 – Develop Product Support Documentation

- V1.1 TS SP 2.3-1, “Establish Interface Descriptions,” and TS SP 2.3-3, “Design Interfaces Using Criteria” are consolidated into a single practice.

Validation

Specific Goal

Prepare for Validation

Specific Practice

1.1 – Select Products for Validation

1.2 – Establish the Validation Environment

1.3 – Establish Validation Procedures and Criteria

Validate Product or Product Components

2.1 – Perform Validation

2.2 – Analyze Validation Results

- Notes were added to VAL to stress that validation activities are performed incrementally and involve relevant stakeholders.
- The phrase “and identify issues” was deleted from the statement of SP 2.2 “Analyze Validation Results” to maintain parallelism with VER SP 3.2 “Analyze Verification Results.”



Verification¹

Specific Goal

Prepare for Verification

Specific Practice

1.1 – Select Work Products for Verification

1.2 – Establish the Verification Environment

1.3 – Establish Verification Procedures and Criteria

Perform Peer Reviews

2.1 – Prepare for Peer Reviews

2.2 – Conduct Peer Reviews

2.3 – Analyze Peer Review Data

- No changes to SG1, SG2, or their practices.



Verification²

Specific Goal

**Verify Selected Work
Products**

Specific Practice

3.1 – Perform Verification

3.2 – Analyze Verification Results

-
- The phrase “and identify corrective action” was deleted from both the title and statement of SP 3.2 “Analyze Verification Results. (Corrective action is handled in PMC SG2, “Manage Corrective Action to Closure.)”



Summary

Many changes were made to the CMMI models to improve quality. The major changes include

- name changed to “CMMI for Development”
- both representations in one document
- amplifications improved; added hardware amplifications
- common features and advanced practices eliminated
- SS addition eliminated; ISM brought into SAM
- guidelines for “not applicable” process areas clarified
- overview and glossary improved
- work environment material added to OPD and IPM
- IPPD material simplified and consolidated
- process deployment strengthened in IPM and OPF



SCAMPI A V1.2 Major Themes

Reduce complexity and ambiguity

Provide additional guidance where needed

Strengthen appraisal planning and conduct

Strengthen appraisal reporting

Define appraisal validity period

Strengthen lead appraiser requirements



Revision Process

The CMMI Steering Group provided a long-term strategy and the upgrade criteria for v1.2.

The SCAMPI Upgrade Team (SUT) reviewed change requests to identify possible changes for the v1.2 appraisal method documents: **Appraisal Requirements for CMMI (ARC)** and **Method Definition Document (MDD)**.

The CMMI Steering Group served as the configuration control board for v1.2 changes to the ARC and MDD.

The SUT developed a draft of the ARC and MDD for review by lead appraisers in May 2006.

The ARC and MDD were released as part of the v1.2 CMMI Product Suite.



Reduce Complexity¹

The requirement for instruments (e.g., questionnaires) was removed.

Only two types of objective evidence are now required:

- documents
- interviews

The following sections in MDD were revised:

- switched **2.2 Verify and Validate Objective Evidence** and **2.3 Document Objective Evidence** so that the order of tasks reflects the natural order of conducting an appraisal
- separated **Verify Objective Evidence** and **Validate Preliminary Findings** to better describe each process



Reduce Complexity²

The use of the term **instantiation** was changed:

- Instantiation is now defined as “the implementation of a model practice used in the appropriate context within the boundaries of an organizational unit.”
- The word “instantiation” for project and organizational-wide entities was replaced with “project” or “support group.”



Reduce Ambiguity

The rating **Not Rated** was clarified:

- Process areas outside of the model scope are rated as **Out of Scope**. For example, for a maturity level 3 appraisal, maturity level 4 and 5 process areas are rated as **Out of Scope**.
- For process areas that have insufficient data to be rated, the rating is **Not Rated**.
- Process areas in the model scope, but outside the organizational scope are rated as **Not Applicable**. The only process area that can be **Not Applicable** is SAM (as determined by the appraisal team).

The practice characterization tables were revised:

- clarified the use of virtual versus live interviews
- changed “face-to-face interviews” to “oral interviews”



Provide Additional Guidance

Guidance for readiness reviews was revised to include team and logistical readiness.

Additional guidance was provided for using virtual methods (e.g., for interviews and briefings).

Additional guidance was provided for using alternative practices (i.e., Appendix C: Alternative Practice Identification and Characterization Guidance).



Strengthen Appraisal Planning and Conduct

Organizational unit sampling was revised to*

- strengthen parameters and limits for organizational sampling (e.g., identifying a minimum number of focus projects)
- include additional criteria for reporting sampling decisions

The **Conduct Appraisal Phase** must now be complete within 90 days.

Appraisal team members are now required to sign final findings.

*Changes to address sampling were extensive. Refer to the MDD for details.



Strengthen Appraisal Reporting

The Appraisal Disclosure Statement (ADS) now requires the following information.

Organizational sampling criteria and decisions (e.g., projects included, projects excluded, percentage of organization represented)

Basis for maturity/capability level 4 and 5 appraisal results

- subprocesses statistically managed
- mapping of these subprocesses to quality and process-performance objectives

Signatures of both the lead appraiser and sponsor

- The lead appraiser affirms that the appraisal scope is representative of the organizational unit.
- The sponsor affirms the accuracy of the ADS and authorizes the SEI to conduct any audits deemed necessary.



Define Appraisal Validity Period

V1.2 appraisal results are valid for a **maximum of 3 years** from the date of the ADS.

V1.1 appraisals will expire on August 31, 2007 or 3 years after the date the appraisal was conducted, whichever is later.



Strengthen Lead Appraiser Requirements

Prior to conducting a v1.2 SCAMPI appraisal, the following must occur:

- Current candidate and authorized lead appraisers and team leaders must complete CMMI v1.2 Upgrade Training.
- Candidate and authorized lead appraisers must attend SCAMPI Face-to-Face Training.
- Those who want to conduct v1.2 SCAMPI level 4 or 5 appraisals must be certified. Certification requirements address the following:
 - education, training, and experience in level 4 and 5 concepts
 - completion of an oral exam



Summary

The SCAMPI A appraisal method was revised based on change requests received to

- reduce complexity and ambiguity
- provide additional guidance where needed
- strengthen appraisal planning and conduct
- strengthen appraisal reporting
- define the appraisal validity period
- strengthen lead appraiser requirements

The changes are intended to make appraisals more accurate, reliable, and efficient.

Training

SEI Training for CMMI

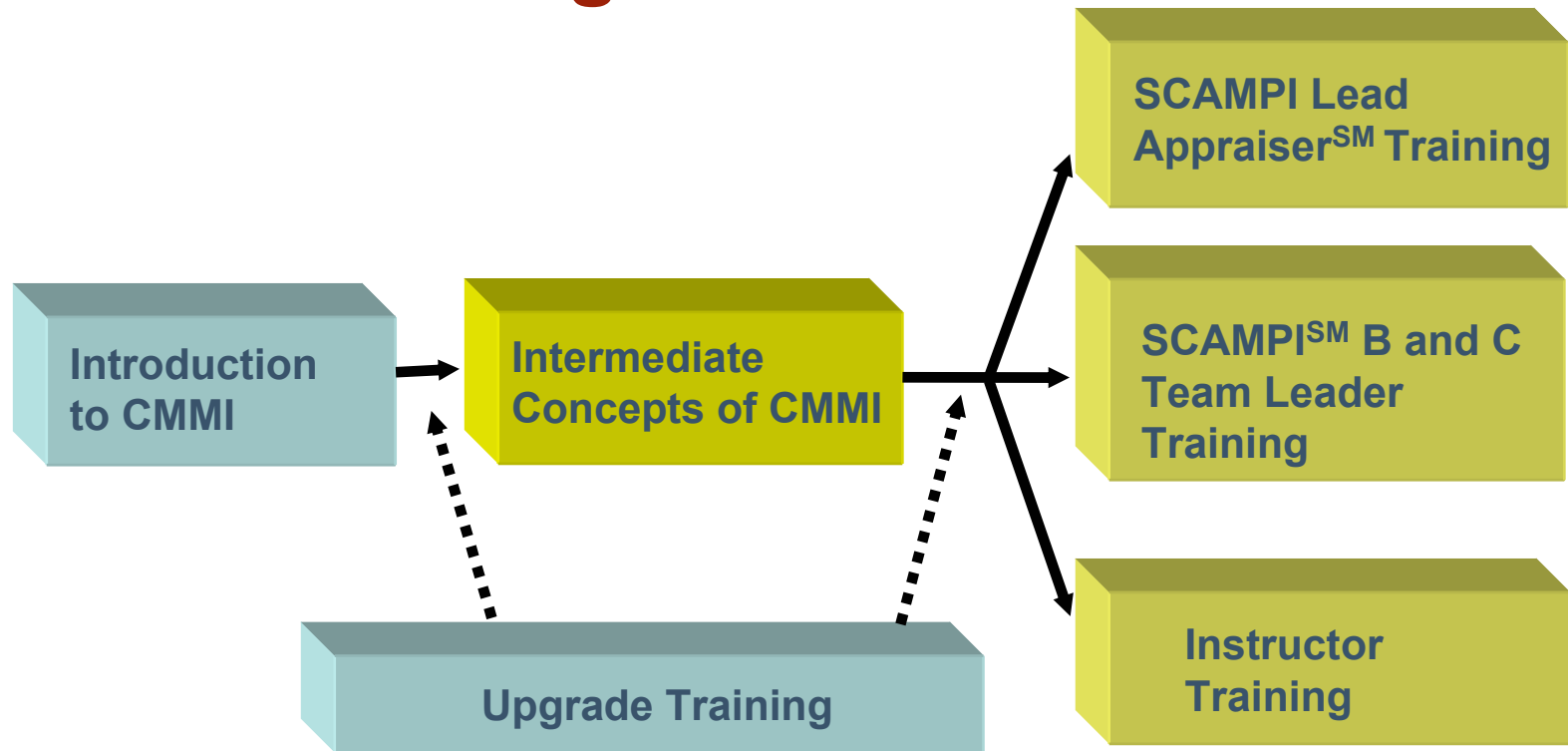



CMMI Training Changes

The following courses have all been updated to address change requests and CMMI Product Suite v1.2 changes:

- Introduction to CMMI
- Intermediate Concepts of CMMI
- CMMI Instructor Training
- SCAMPI Lead Appraiser Training
- SCAMPI B and C Team Leader Training

CMMI v1.2 Upgrade Training was also developed to help users move from v1.1 to v1.2, an online course with potential SEI Partner assistance



Examinations

The construction and format of examinations have changed. v1.1 tests were largely short answer tests that were the same for all students.

For v1.2, tests will be generated from an item bank and now will be multiple choice. CMMI v1.2 Upgrade Training for Instructors, Lead Appraisers, and Team Leaders is the first course to use this approach. The Intermediate Concepts of CMMI and Instructor Training will follow.



Multiple Choice Examinations

This new approach, using an item bank and multiple choice questions, allows multiple versions of examinations that can be constructed more easily:

- The sequence of multiple choice responses can vary from test to test.
- The order of questions can vary from test to test.
- The selection of questions can vary from test to test, but cover the same categories.

This new approach allows us to

- add, modify, and delete questions from the test more easily
- better evaluate the student's knowledge

Related Work



Applying CMMI in Small Settings

Where are we with our work in small settings?

- completed technical feasibility pilots in Huntsville, Alabama with two small companies in the US Army supply chain
- posted the toolkit from this pilot for review:
 - <http://www.sei.cmu.edu/ttp/publications/toolkit>
- chartered a project to further research in and evolve guidance for CMMI in Small Settings (CSS)

Where are we going?

- International Research Workshop for Process Improvement in Small Settings held October 19-20, 2005
- call for Interest in CSS project is posted on SEI web:
 - <http://www.sei.cmu.edu/cmml/acss/participation.html>

Acquisition Improvement is needed....

Acquirers cannot ensure that mature processes are applied to their programs

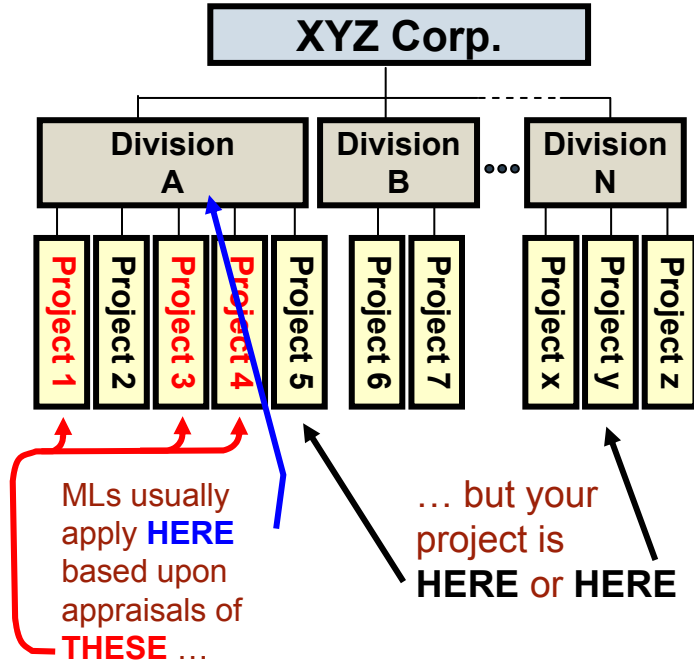

Acquirers need more internal process focus

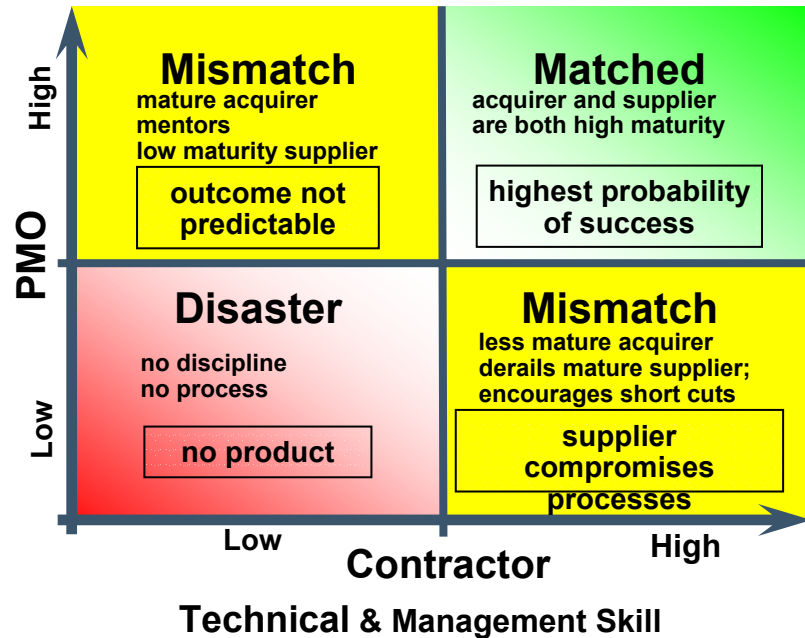



Guidebook Concept

Provide a toolbox for the acquirer to aid in ensuring that the current project benefits from the application of mature processes

- Include practical guidance on how to recognize the real practitioners and identify the abusers
- Encourage the use of capability and maturity profiles, and discourage the use of the "single level" approach
- Improve acquisition organizations' understanding of the meaning of high maturity (levels 4 and 5) and equivalent staging



But what about the rest of the model?

Some may wish a refresher

Others may need the basics, as well as the changes

These next charts attempt to fill the gaps....

Model Basics



Critical Distinctions Among Processes

performed vs. **managed**
the extent to which the process is planned; performance is managed against the plan; corrective actions are taken when needed

managed vs. **defined**
the scope of application of the process descriptions, standards, and procedures (i.e., project vs. organization)

defined vs. **quantitatively managed**
the predictability of process performance

quantitatively managed vs. **optimizing**
whether the process is continually improved by addressing common causes of process variation

Summary of Generic Goals and Practices

<i>Generic Goals</i>	<i>Generic Practices</i>
GG1: Achieve Specific Goals	GP 1.1: Perform Specific Practices
GG2: Institutionalize a Managed Process	GP 2.1: Establish an Organizational Policy GP 2.2: Plan the Process GP 2.3: Provide Resources GP 2.4: Assign Responsibility GP 2.5: Train People GP 2.6: Manage Configurations GP 2.7: Identify and Involve Relevant Stakeholders GP 2.8: Monitor and Control the Process GP 2.9: Objectively Evaluate Adherence GP 2.10: Review Status with Higher Level Management
GG3: Institutionalize a Defined Process	GP 3.1: Establish a Defined Process GP 3.2: Collect Improvement Information
GG4: Institutionalize a Quantitatively Managed Process	GP 4.1: Establish Quantitative Objectives for the Process GP 4.2: Stabilize Subprocess Performance
GG5: Institutionalize an Optimizing Process	GP 5.1: Ensure Continuous Process Improvement GP 5.2: Correct Root Causes of Problems

Adapted from
Cepeda Systems &
Software Analysis, Inc.

Continuous Representation: PAs by Categories

Category	Process Areas
Process Management	Organizational Process Focus Organizational Process Definition +IPPD Organizational Training Organizational Process Performance Organizational Innovation and Deployment
Project Management	Project Planning Project Monitoring and Control Supplier Agreement Management Integrated Project Management +IPPD Risk Management Quantitative Project Management
Engineering	Requirements Management Requirements Development Technical Solution Product Integration Verification Validation
Support	Configuration Management Process and Product Quality Assurance Measurement and Analysis Decision Analysis and Resolution Causal Analysis and Resolution

Staged Representation: PAs by Maturity Level

Level	Focus	Process Areas	Quality Productivity
5 Optimizing	<i>Continuous Process Improvement</i>	Organizational Innovation and Deployment Causal Analysis and Resolution	
4 Quantitatively Managed	<i>Quantitative Management</i>	Organizational Process Performance Quantitative Project Management	
3 Defined	<i>Process Standardization</i>	Requirements Development Technical Solution Product Integration Verification Validation Organizational Process Focus Organizational Process Definition +IPPD Organizational Training Integrated Project Management +IPPD Risk Management Decision Analysis and Resolution	
2 Managed	<i>Basic Project Management</i>	Requirements Management Project Planning Project Monitoring and Control Supplier Agreement Management Measurement and Analysis Process and Product Quality Assurance Configuration Management	
1 Initial			



Understanding Levels

Levels are used in CMMI to describe an evolutionary path for an organization that wants to improve the processes it uses to develop and maintain its products and services.

CMMI supports two improvement paths:

- **continuous** - enabling an organization to incrementally improve processes corresponding to an individual process area (or set of process areas) selected by the organization
- **staged** - enabling the organization to improve a set of related processes by incrementally addressing successive predefined sets of process areas



Achieving Capability Levels (CL) for a Process Area

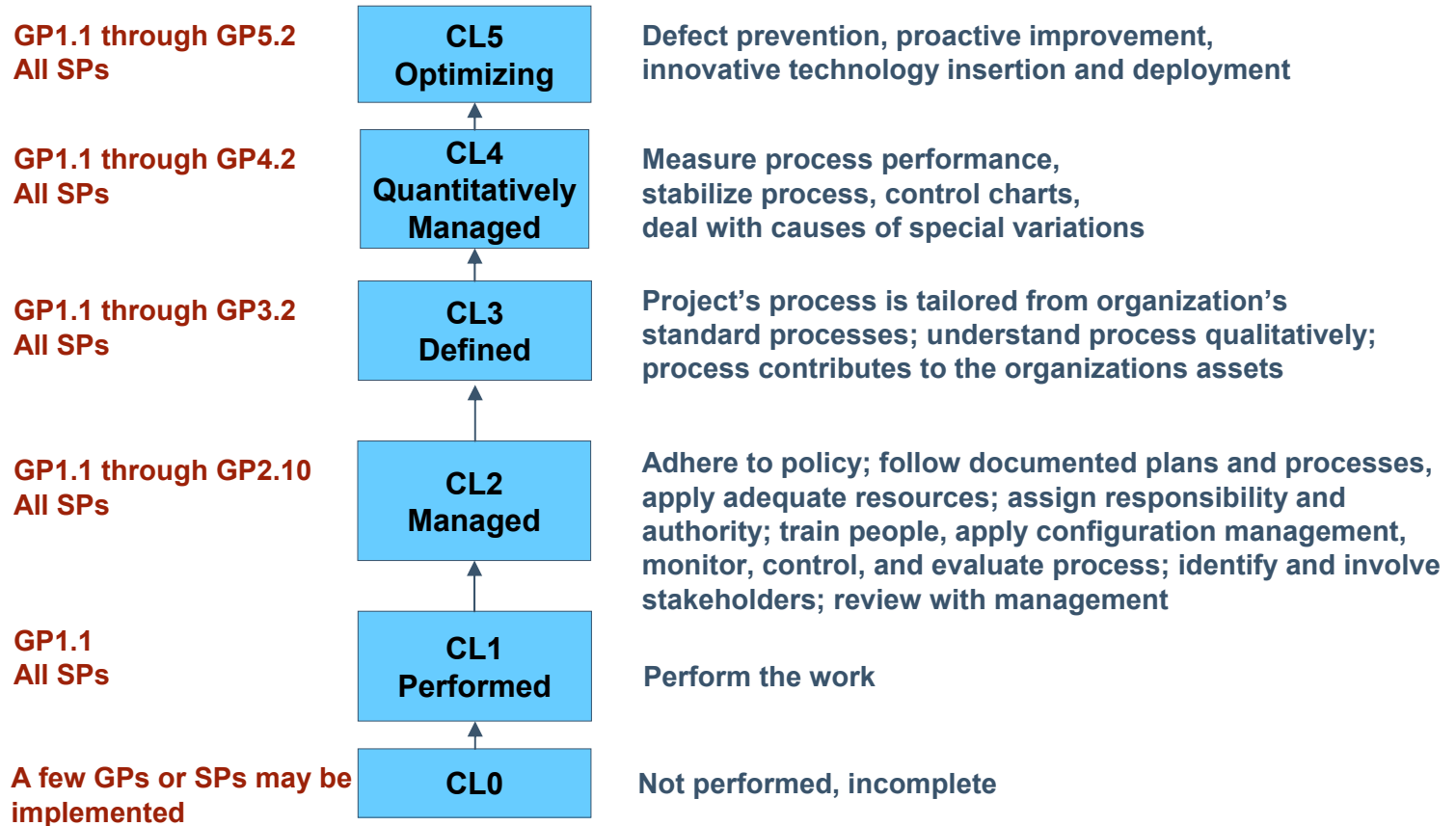



Achieving Maturity Levels

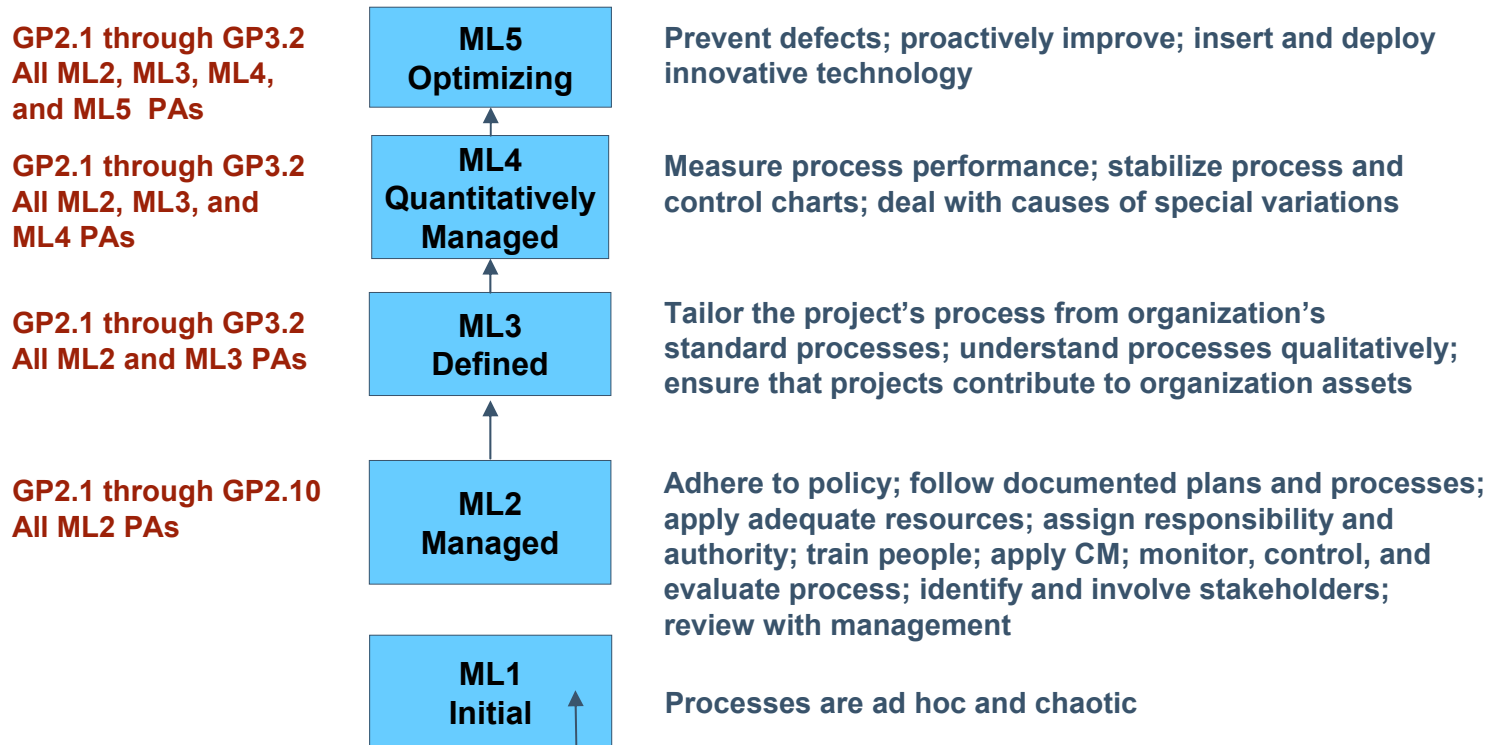

Process Area Components

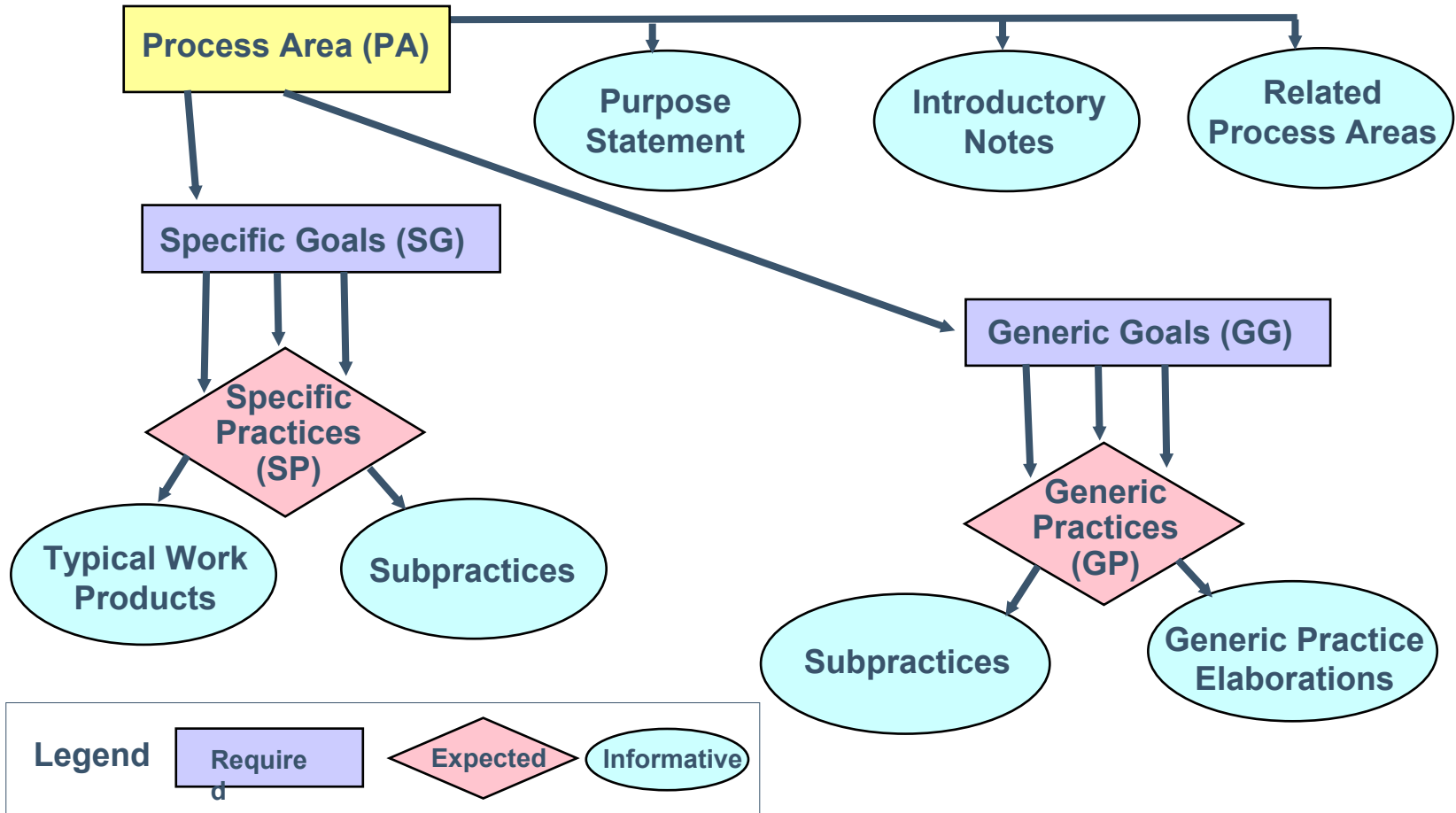

Interaction Between OPD and IPM

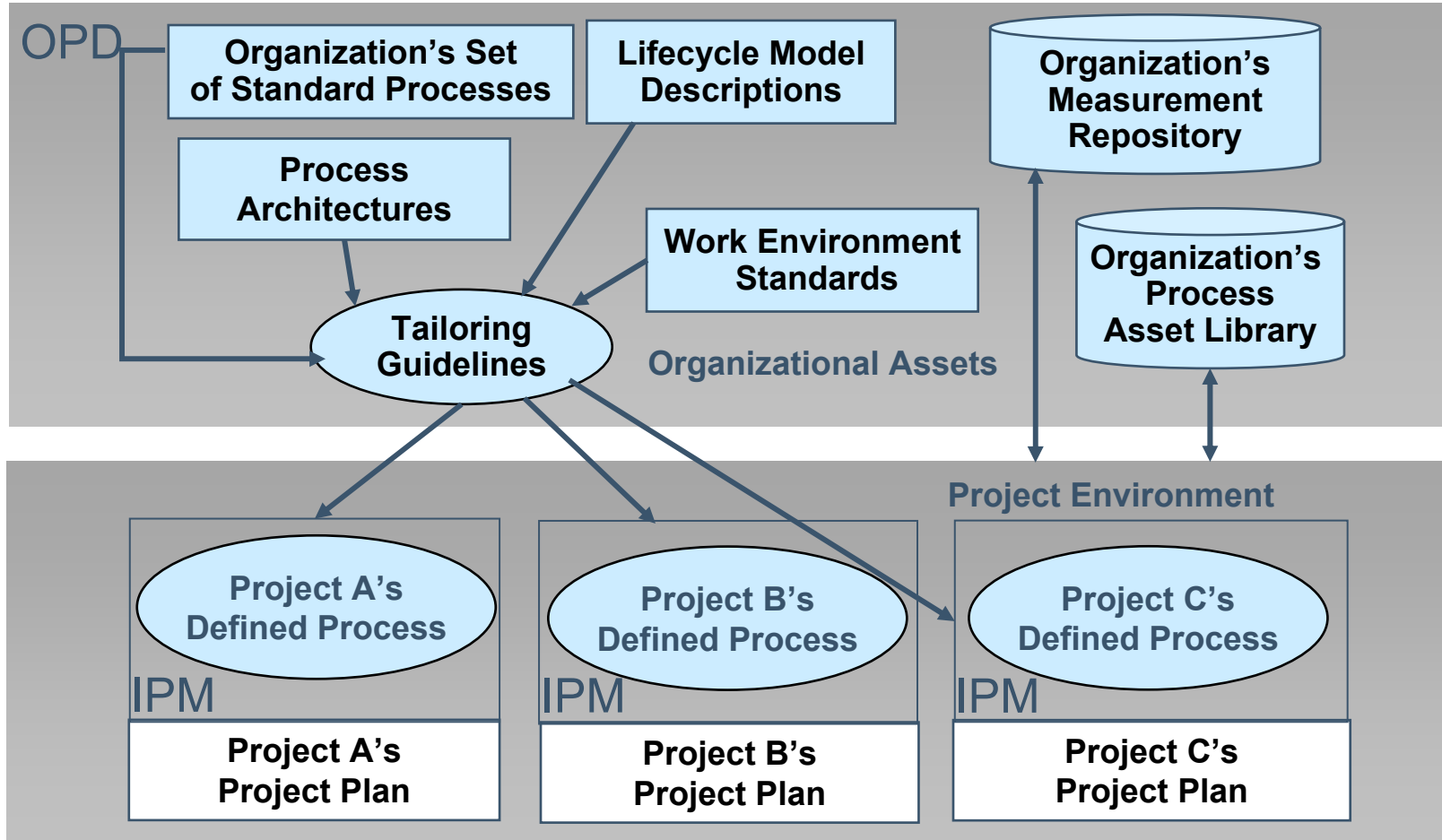

Process definition inputs

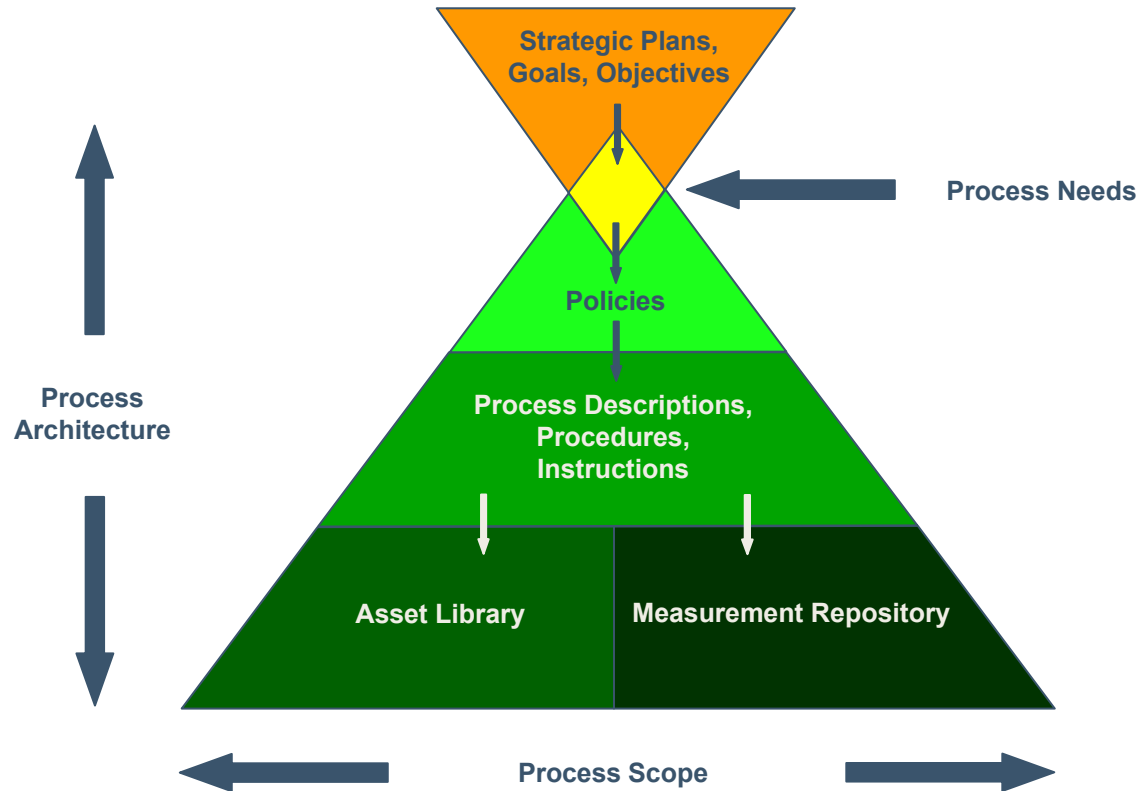



Causal Analysis and Resolution Goals

SG 1: Determine Causes of Defects

Root causes of defects and other problems are systematically determined.

SG 2: Address Causes of Defects

Root causes of defects and other problems are systematically addressed to prevent their future occurrence.

The process area also has generic goals to support institutionalization.

Note relationship with
Causal Analysis and Resolution





The other Process Areas....

- In the earlier segments, we covered the nine Process Areas changed for V1.2
 - IPM, OPD, OPF, RD, REQM, SAM, TS, VAL, VER
- Following are the remaining 13 without significant change....
 - CAR, CM, DAR, MA, OID, OPP, OT, PI, PMC, PP, PPQA, QPM, RSKM



Configuration Management Goals

SG 1: Establish Baselines

Baselines of identified work products are established.

SG 2: Track and Control Changes

Changes to the work products under configuration management are tracked and controlled.

SG 3: Establish Integrity

Integrity of baselines is established and maintained.

The process area also has generic goals to support institutionalization.

Note relationship with
Configuration Management



GP 2.6



Decision Analysis and Resolution Goals

SG 1: Evaluate Alternatives

Decisions are based on an evaluation of alternatives using established criteria.

The process area also has generic goals to support institutionalization.



Measurement and Analysis Goals

SG 1: Align Measurement and Analysis Activities

Measurement objectives and activities are aligned with identified information needs and objectives.

SG 2: Provide Measurement Results

Measurement results that address identified information needs and objectives are provided.

The process area also has generic goals to support institutionalization.



Organizational Innovation and Deployment Goals

SG 1: Select Improvements

Process and technology improvements that contribute to meeting quality and process-performance objectives are selected.

SG 2: Deploy Improvements

Measurable improvements to the organization's processes and technologies are continually and systematically deployed.

The process area also has generic goals to support institutionalization.

Note relationship with

Organizational Innovation and Deployment  GP 5.1



Organizational Process Performance Goals

SG 1: Establish Performance Baselines and Models

Baselines and models that characterize the expected process performance of the organization's set of standard processes are established and maintained.

The process area also has generic goals to support institutionalization.

Note relationship with

Organizational Process Performance ↔ GP 4.1

OPP Context

The shaded SPs inter-relate and may need to be performed iteratively.

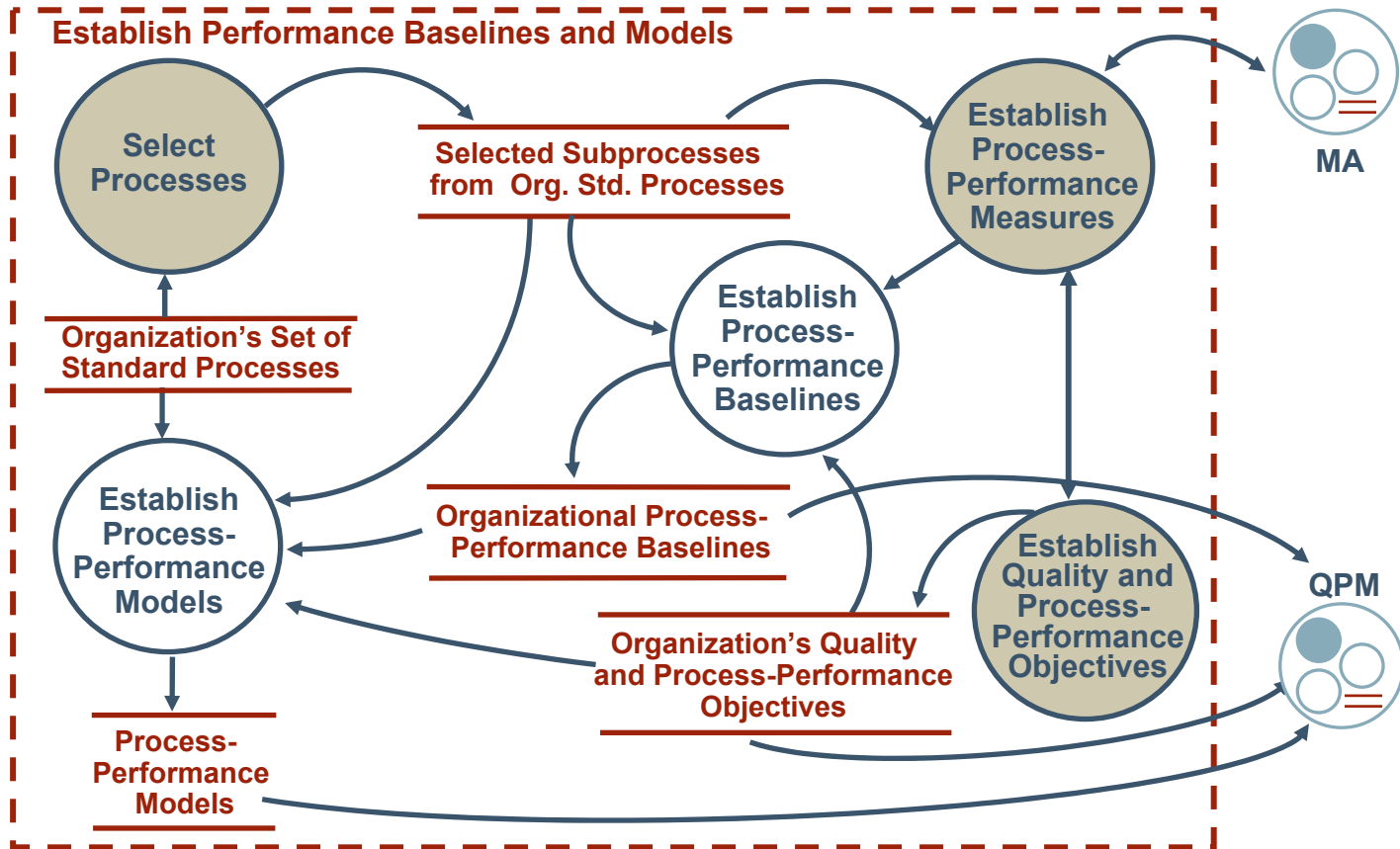



Organizational Training Goals

SG 1: Establish an Organizational Training Capability

A training capability that supports the organization's management and technical roles is established and maintained.

SG 2: Provide Necessary Training

Training necessary for individuals to perform their roles effectively is provided.

The process area also has generic goals to support institutionalization.

Note relationship with
Organizational Training ↔ GP 2.5



Product Integration Goals

SG 1: Prepare for Product Integration

Preparation for product integration is conducted.

SG 2: Ensure Interface Compatibility

The product component interfaces, both internal and external, are compatible.

SG 3: Assemble Product Components and Deliver the Product

Verified product components are assembled and the integrated, verified, and validated product is delivered.

The process area also has generic goals to support institutionalization.



Project Monitoring and Control Goals

SG 1: Monitor Project Against Plan

Actual performance and progress of the project are monitored against the project plan.

SG 2: Manage Corrective Action to Closure

Corrective actions are managed to closure when the project's performance or results deviate significantly from the plan.

The process area also has generic goals to support institutionalization.

Note relationship with
Project Monitoring and Control  GP 2.8



Project Planning Goals

SG 1: Establish Estimates

Estimates of project planning parameters are established and maintained.

SG 2: Develop a Project Plan

A project plan is established and maintained as the basis for managing the project.

SG 3: Obtain Commitment to the Plan

Commitments to the project plan are established and maintained.

The process area also has generic goals to support institutionalization.

Note relationship with
Project Planning  GP 2.2, GP 2.7



Process and Product Quality Assurance Goals

SG 1: Objectively Evaluate Processes and Work Products

Adherence of the performed process and associated work products and services to applicable process descriptions, standards, and procedures is objectively evaluated.

SG 2: Provide Objective Insight

Noncompliance issues are objectively tracked and communicated, and resolution is ensured.

The process area also has generic goals to support institutionalization.

Note relationship with

Process and Product Quality Assurance ↔ GP 2.9



Quantitative Project Management Goals

SG 1: Quantitatively Manage the Project

The project is quantitatively managed using quality and process-performance objectives.

SG 2: Statistically Manage Subprocess Performance

The performance of selected subprocesses within the project's defined process is statistically managed.

The process area also has generic goals to support institutionalization.

Note relationship with

Quantitative Project Management \Leftrightarrow GP 4.1, GP 4.2



Risk Management Goals

SG 1: Prepare for Risk Management

Preparation for risk management is conducted.

SG 2: Identify and Analyze Risks

Risks are identified and analyzed to determine their relative importance.

SG 3: Mitigate Risks

Risks are handled and mitigated, where appropriate, to reduce adverse impacts on achieving objectives.

The process area also has generic goals to support institutionalization.



For More Information...

For more information about CMMI

- <http://www.sei.cmu.edu/cmmi/> (main CMMI site)

Other Web sites of interest include

- <http://seir.sei.cmu.edu/seir/> (Software Engineering Information Repository)
- <http://dtic.mil/ndia> (annual CMMI Technology Conferences)
- <http://seir.sei.cmu.edu/pars> (publicly released SCAMPI appraisal summaries)
- <https://bscw.sei.cmu.edu/pub/bscw.cgi/0/79783>

Or, contact

SEI Customer Relations

Phone: 412 / 268-5800

Email: customer-relations@sei.cmu.edu