

INVESTIGATION OF A LASER-CONTROLLED, COPPER-DOPED GaAs CLOSING AND OPENING SWITCH FOR PULSED POWER APPLICATIONS

D.C. Stoudt, R.A. Roush, M.S. Mazzola, and S.F. Griffiths

Pulsed Power Technology Branch (Code F45)
Naval Surface Warfare Center
Dahlgren, Virginia 22448

ABSTRACT

This paper describes the recent power scaling of the Bulk Optically Controlled Semiconductor Switch (BOSS). The processes of persistent photoconductivity followed by photo-quenching have been demonstrated in copper-compensated, silicon-doped, semi-insulating GaAs (GaAs:Cu:Si). These processes allow a switch to be developed which can be closed by the application of one laser pulse and opened by the application of a second laser pulse of longer wavelength. The high-power switching results indicate that the BOSS device will operate at multi-megawatt power levels. The results of our power scaling effort have suggested improvements to the basic BOSS design that will allow us to achieve reliable operation at high power levels.

INTRODUCTION

Photoconductive switches made from semi-insulating GaAs were proposed in the late 1970's for use as both closing and opening high-power switches [1]. Closing is achieved by exciting electrons from the valence band into the conduction band using a laser with a photon energy greater than that of the bandgap. Switch opening times are given by the electron-hole recombination lifetime found in GaAs. Therefore, the electrical pulse would temporally resemble the laser pulse. Some of the disadvantages of this switching mechanism are that the fast recombination rate represents a conductivity loss mechanism which requires additional photons. Also, the pulse width of the electrical pulse, which is determined by the laser pulse, is not easily changed. The process, where one absorbed photon results in one electron in the conduction band, is called linear photoconductivity.

An alternative method to direct excitation across the bandgap was proposed by Schoenbach, et al.[2]. This concept, which is called the Bulk Optically Controlled Semiconductor Switch (BOSS), relies on persistent photoconductivity followed by photo-quenching to provide both switch closing and opening, respectively. Persistent photoconductivity results from the excitation of electrons from the deep copper centers found in copper-compensated, silicon-doped, semi-insulating GaAs (GaAs:Si:Cu). The small cross-section for electron capture back into the Cu centers allows long conduction times (tens of microseconds) after the first laser pulse. Photo-quenching is accomplished by the application of a second laser pulse of longer wavelength which elevates electrons from the valence band back into the copper levels. This laser pulse floods the valence band with free holes which rapidly recombine with free electrons to quench the photoconductivity over a time scale given by the electron-hole lifetime of the material, which can be subnanosecond. These processes allow a switch to be developed which can be closed by the application of one laser pulse ($\lambda \approx 1 \mu\text{m}$) and opened by the application of a second laser pulse ($\lambda \approx 2 \mu\text{m}$). The 1- μm laser wavelength provides enough energy to elevate electrons from the dominant copper center (Cu_3) into the conduction band without elevating electrons directly from the valence band to the conduction band. The 2- μm laser wavelength provides sufficient energy to elevate electrons from the valence band into the Cu_3 center, but insufficient energy to allow electrons to be excited from the valence band to the conduction band by a two-photon process. If the energy is greater than half the bandgap, a spike would appear in the current waveform during the second laser pulse [3].

The purpose of this paper is to describe the most recent results of our efforts to scale the BOSS switch to high powers. Some of the important transport phenomena associated with scaling these devices are discussed by Mazzola, et al. in a companion paper [4].

SAMPLE PREPARATION

Low resistivity, silicon-doped (n-type) GaAs can be made semi-insulating by the introduction of acceptor levels through a thermal diffusion process. One defect, among several formed by copper in GaAs, is a deep acceptor known as Cu_3 which is located 0.44 eV above the valence band. By thermally diffusing the proper concentration of copper into the n-type material, it is possible to achieve resistivities as high as $10^8 \Omega\text{-cm}$ at 300 K [5].

The samples used in this investigation were taken from a GaAs crystal grown using the horizontal Bridgman technique [6]. The material was originally doped with a silicon concentration of $\sim 2 \times 10^{16} \text{ cm}^{-3}$ which yielded a resistivity of about $7 \times 10^{-2} \Omega\text{-cm}$. The samples were degreased and RF sputter cleaned prior to the deposition of a 1 μm copper layer on both sides of the crystal. Each sample was then loaded into a "super-sil" (spectroscopy grade) quartz ampoule which was loaded with pure arsenic and evacuated down to $\sim 10^{-6}$ torr. An arsenic overpressure is provided to minimize the decomposition of the GaAs during the high temperature anneal. The ampoules were then placed in a diffusion furnace and annealed at $\sim 570^\circ\text{C}$ for 4 hours. After the diffusion the ampoules were opened and the samples were polished on both sides to a mirror finish.

The sample dimensions were 12 mm by 20 mm by ~ 0.4 mm thick. An illustration of the sample geometries and the laser pumping schemes (to be discussed in the next section) is given in Fig. 1. On the first sample (82-5), coplanar contacts were deposited with an active length of 1 cm and a separation across the surface of the sample of 1 cm. The second sample (86-3) had the same contact dimensions, however, the contacts were placed on opposite sides of the crystal. This geometry results in a offset, over-under contact configuration which was used because it reduces the electric field along the surface of the semiconductor. This should help to prevent a flashover in the surrounding dielectric, and decrease the current crowding effects at the contact edge by reducing the electric field there.

The contact metalization used was a 50 \AA nickel layer followed by a 1000 \AA Au:Ge (88%:12%) layer. The contacts were then annealed at 450°C for about 10 minutes. Silver epoxy was used to attach the electrical leads to the sample. Dark I-V characteristics of the two samples yielded an estimated resistivity of $2.5 \times 10^6 \Omega\text{-cm}$ for 82-5 and $8 \times 10^6 \Omega\text{-cm}$ for 86-3. This resulted in an increase of the material resistivity by about eight orders of magnitude through compensation.

EXPERIMENTAL SETUP

Photoconductivity measurements were performed to evaluate the operation of a BOSS device at high power. Two lasers were used to allow two consecutive laser pulses to illuminate the sample, one to close the switch, and the other to open it. A Q-switched Nd:YAG laser ($\lambda \approx 1.06 \mu\text{m}$, $h\nu = 1.17 \text{ eV}$) was used to "turn-on" the switch. The laser had a Gaussian temporal shape (FWHM $\approx 30 \text{ ns}$) with an incident energy of approximately 10 mJ. The "turn-off" laser pulse was provided by a Q-switched

Report Documentation Page

Form Approved
OMB No. 0704-0188

Public reporting burden for the collection of information is estimated to average 1 hour per response, including the time for reviewing instructions, searching existing data sources, gathering and maintaining the data needed, and completing and reviewing the collection of information. Send comments regarding this burden estimate or any other aspect of this collection of information, including suggestions for reducing this burden, to Washington Headquarters Services, Directorate for Information Operations and Reports, 1215 Jefferson Davis Highway, Suite 1204, Arlington VA 22202-4302. Respondents should be aware that notwithstanding any other provision of law, no person shall be subject to a penalty for failing to comply with a collection of information if it does not display a currently valid OMB control number.

| | | | |
|---|------------------------------------|--|--|
| 1. REPORT DATE JUN 1991 | 2. REPORT TYPE N/A | 3. DATES COVERED - | |
| 4. TITLE AND SUBTITLE Investigation Of A Laser-Controlled, Copper-Doped Gaas Closing And Opening Switch For Pulsed Power Applications | | 5a. CONTRACT NUMBER | |
| | | 5b. GRANT NUMBER | |
| | | 5c. PROGRAM ELEMENT NUMBER | |
| 6. AUTHOR(S) | | 5d. PROJECT NUMBER | |
| | | 5e. TASK NUMBER | |
| | | 5f. WORK UNIT NUMBER | |
| 7. PERFORMING ORGANIZATION NAME(S) AND ADDRESS(ES) Pulsed Power Technology Branch (Code F45) Naval Surface Warfare Center Dahlgren, Virginia 22448 | | 8. PERFORMING ORGANIZATION REPORT NUMBER | |
| 9. SPONSORING/MONITORING AGENCY NAME(S) AND ADDRESS(ES) | | 10. SPONSOR/MONITOR'S ACRONYM(S) | |
| | | 11. SPONSOR/MONITOR'S REPORT NUMBER(S) | |
| 12. DISTRIBUTION/AVAILABILITY STATEMENT Approved for public release, distribution unlimited | | | |
| 13. SUPPLEMENTARY NOTES See also ADM002371. 2013 IEEE Pulsed Power Conference, Digest of Technical Papers 1976-2013, and Abstracts of the 2013 IEEE International Conference on Plasma Science. Held in San Francisco, CA on 16-21 June 2013. U.S. Government or Federal Purpose Rights License. | | | |
| 14. ABSTRACT This paper describes the recent power scaling of the ~ulk Optically Controlled ~emiconductor ~witch (BOSS). The processes of persistent photoconductivity followed by photo-quenching have been demonstrated in copper-compensated, silicon-doped, semi-insulating GaAs (GaAs:Cu:Si). These processes allow a switch to be developed which can be closed by the application of one laser pulse and opened by the application of a second laser pulse of longer wavelength. The high-power switching results indicate that the BOSS device will operate at multi-megawatt power levels. The results of our power scaling effort have suggested improvements to the basic BOSS design that will allow us to achieve reliable operation at high power levels. | | | |
| 15. SUBJECT TERMS | | | |
| 16. SECURITY CLASSIFICATION OF: | | | 17. LIMITATION OF ABSTRACT SAR |
| a. REPORT unclassified | b. ABSTRACT unclassified | c. THIS PAGE unclassified | |
| | | | 18. NUMBER OF PAGES 4 |
| | | | 19a. NAME OF RESPONSIBLE PERSON |

Ho:YAG laser ($\lambda \approx 2.09 \mu\text{m}$, $h\nu = 0.59 \text{ eV}$) with a FWHM of 125 ns, and an incident energy of about 20 mJ.

As mentioned earlier, Fig. 1 illustrates the laser pumping scheme used for the two samples. Both samples were immersed in transformer oil to prevent a surface breakdown. For 82-5, a face-pumped geometry was used where the laser pulses were first passed through quartz homogenizers prior to illuminating the active area between the two coplanar contacts (Fig. 1a). Unfortunately, for this configuration, the 0.4 mm thickness allows for only about 13% of the light entering the sample to be absorbed. This assumes an absorption depth of 3 mm for $\lambda = 1.06 \mu\text{m}$ in GaAs:Si:Cu [7]. The absorption depth of the 2.09- μm radiation in this material is not known; however, it is reasonable to assume that it is no less than 3 mm and probably much longer. The end result is that, for our geometry and laser wavelengths, the face-pumping scheme is not a very efficient way of coupling the laser photons into the switch. For this reason a side-pumping scheme was used for sample 86-3 (Fig. 1b). In this case, a cylindrical lens was used to produce a very narrow line about 1 cm long which was focused onto the edge of the sample.

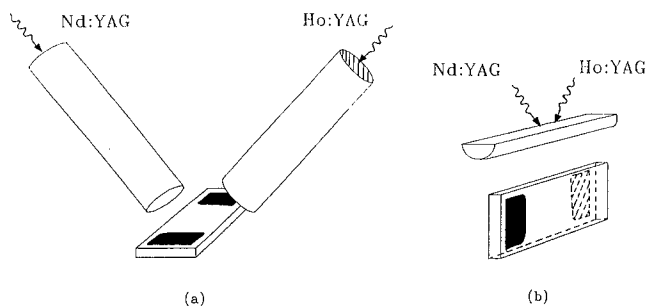

Fig. 1. Switch geometries and pumping schemes (a) 82-5, (b) 86-3.

The bias circuit used for high-power testing is shown in Fig. 2. The 5- Ω pulse forming network (PFN) was charged with a negative bias, therefore, when the spark gap was triggered, a 12- μs positive voltage pulse would be developed across the 5- Ω PFN load. This voltage, which is equal to half of the charging voltage, would then be applied across both the 50- Ω load and the GaAs switch. The load line was experimentally measured to be 53.5 Ω for the actual circuit. The current through the switch was measured using a 0.1- Ω current viewing resistor (CVR) and the switch voltage was measured using a simple resistive voltage divider. The voltage and current were measured using a HP 54111 digitizer.

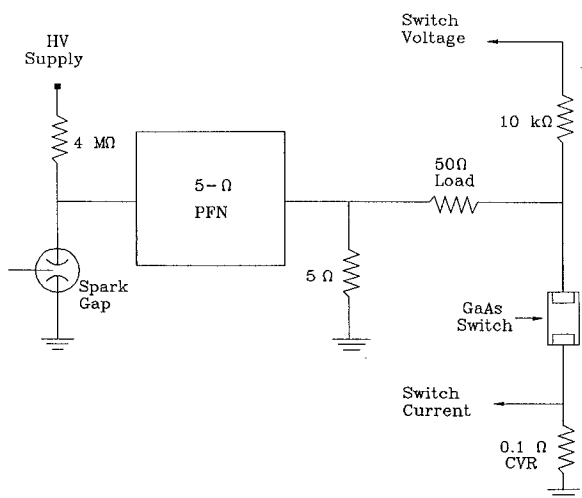

Fig. 2. High voltage switch test bed.

EXPERIMENTAL RESULTS

Figure 3 demonstrates a typical switching event, at an applied voltage of $\sim 1.1 \text{ kV}$, for both of the samples being tested. During the application of the first laser pulse, both waveforms rapidly rise to a peak current of 16 A and then decay to a long time constant "tail current." It is clearly evident that the current trace for 82-5 (solid line) decays more rapidly than the trace for 86-3 which was turned off after about 1 μs (dashed). One possible explanation for difference requires looking at the kinetics of carrier trapping processes and their dependence on the compensation process. When the bulk material is compensated, the amount of copper introduced in relation to the silicon doping density, strongly effects final bulk resistivity. The dominant process which controls the time constant of the tail conductivity is the thermal emission of holes from the Cu_b level and their subsequent recombination with free electrons [8]. The result is that Sample 82-5 may have had a lower resistivity ($2.5 \times 10^6 \Omega\text{-cm}$) than sample 86-3 ($8 \times 10^6 \Omega\text{-cm}$) because it had a slightly higher copper concentration. Therefore, the tail conductivity of sample 82-5 should decay faster because the hole emission rate increases with the initial density of holes trapped at Cu_b [9]. The reason for the difference in bulk resistivity is not clear, however, it is thought to be the result of either a nonuniformity in the initial silicon density or an unevenly compensated bulk crystal. These bulk properties are currently under investigation.

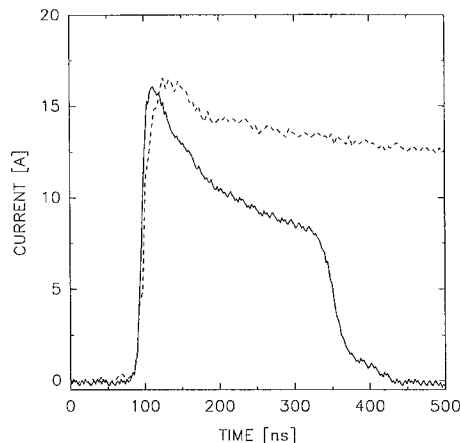

Fig. 3. Typical "linear" photocurrent waveforms for a bias of 1.1 kV (82-5:solid, 86-3:dashed).

As the applied voltage is increased, there is a qualitative variation in the temporal behavior of the switch. An example of this is shown in Fig. 4, where an initial voltage of 4.3 kV was applied across the switch. For this waveform, we see the same rapid rise of the current shown in Fig. 3, however, after the end of the first laser pulse, the current decreases from about 61 A to about 42 A and then begins increasing to 44 A prior to the second laser pulse. It is not possible to precisely explain this behavior without at least a one-dimensional, time-dependent model; however, we believe that it results from charge injection at the contact(s). It is interesting to note that, in Fig. 4, the switch current was completely interrupted by the application of the second laser pulse, even though the tail current was not strictly a persistent photocurrent.

The cumulative data for the switching experiments on both samples is shown in Fig. 5. The peak data corresponds to the peak current and minimum voltage of the switch during the first laser pulse. The tail data corresponds to the tail current and voltage 500 ns after the initial rise in switch current. Several features of the data in this figure can be discussed. The peak current appears to be linear up to about 50 to 60 A and then shows a tendency to saturate. Prior to saturation,

the switch resistance for both devices was about 7Ω . It is interesting to note that even with the different switch configurations and laser pumping schemes, the peak data for both samples yields the same on-state resistance. The scatter in the data in the linear range is primarily due to deviations in the Nd:YAG laser pulse, which had a 30% pulse-to-pulse intensity variation. Near saturation the peak data shows an increased sensitivity to laser fluctuations which is an indication of a threshold effect in the current transport through the switch. The saturation of the peak illumination current has previously been observed [10], and discussed [11]. Further details can also be found in the companion paper in these proceedings [4].

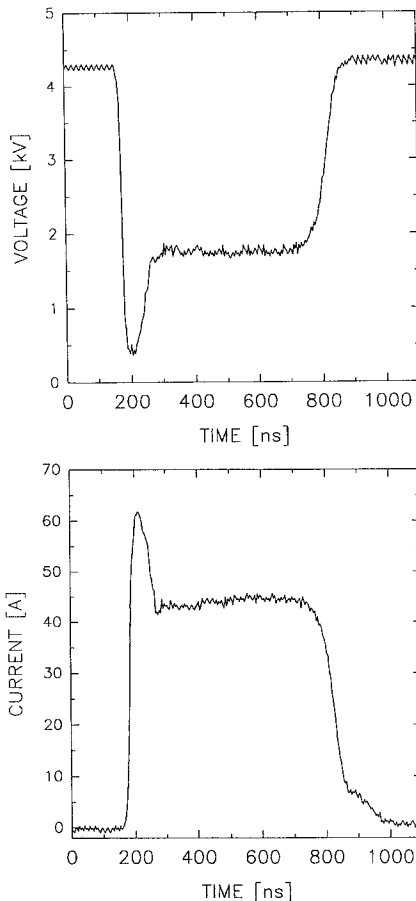

Fig. 4. Voltage and current trace of a switching cycle.

Also shown in Fig. 5 is the data corresponding to the tail current and voltage. Unlike the peak data, there is a notable difference in the tail data for the two samples. Both samples show a fairly linear dependence at lower on-state voltages followed by a super-linear characteristic. Sample 82-5 had an on-state resistance of about 70Ω in the linear regime while 86-3 had a resistance of about 35Ω . This difference in on-state resistance agrees with the explanation given earlier concerning the decay time of the tail conductivity. If the tail conductivity for sample 82-5 decays faster than 86-3, then given the same initial peak conductivity and the same measurement time after the first laser pulse, sample 86-3 should have a lower tail resistance. The super-linear increase in tail conductivity is not so easily explained. It is clear that the change in slope of the tail data corresponds to the voltages where the tail current no longer exhibited the expected conductivity decay time (Fig. 4).

As discussed earlier, when the tail conductivity decay time initially started to increase, all of the tail current could still be extinguished by the second laser pulse. However, when the voltage was further increased,

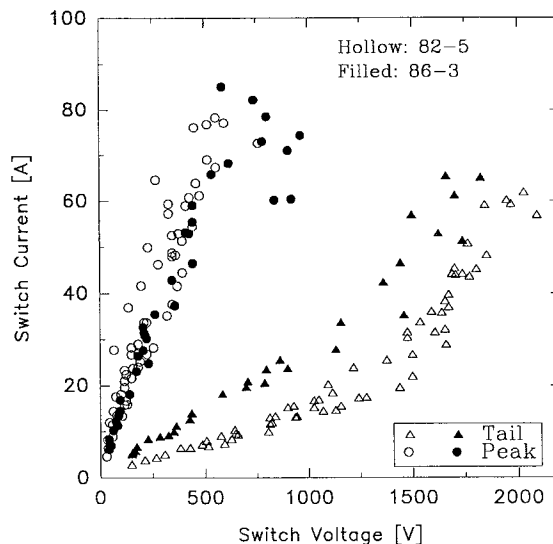

Fig. 5. Peak and tail I-V characteristics.

the switch would not turn off completely. In fact, not only was the tail current not turning all the way off, but it started to increase after the second laser pulse ended, as shown in Fig. 6. This is very similar to the dark current time development measured in as-grown, semi-insulating GaAs, both with a pulsed bias [12], and following electron beam irradiation (175 keV) [13],[14]. In Fig. 6, the positive slope of the tail current is much greater than that shown in Fig. 4. This slope also appears to match the slope of the current after the second laser pulse. The calculated power being dissipated in the switch during the tail current is about 120 kW for a current of 60 A and a tail voltage of 2000 V. Clearly, at these power levels, thermal processes in both the semiconductor and at the contact boundaries cannot be ignored. Therefore, during the tail phase of conduction, the current consists of both a persistent photocurrent and a thermally generated (or injected) current. Thus, the "turn-off" laser pulse will only extinguish that portion of the current resulting from persistent photoconductivity and not the thermal current. This current will continue to flow, dissipating more power, resulting in a thermal runaway process. In Fig. 6, the current finally starts to decrease as the PFN energy is depleted. In future research it will, therefore, be necessary to optimize material processing to increase the tail conductivity and operate at reduced pulse widths to minimize the power dissipated in the switch.

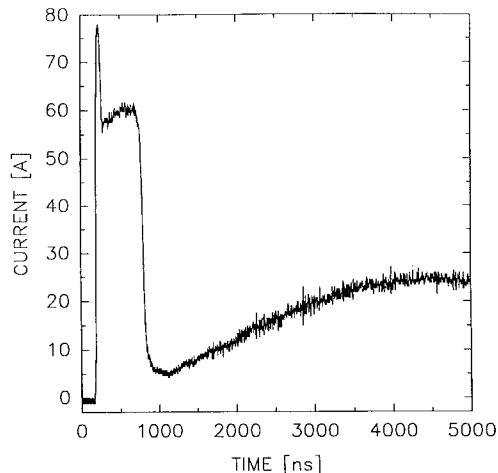

Fig. 6. Photocurrent pulse showing thermal rise of current after the switching event.

SWITCH FAILURE

Up to this point, nothing has been said about the failure mode of the switches at high power. When discussing switch failure, we have to be careful to separate the initiating mechanism and the resulting damage to the switch. It is very clear that the final failure mode of these, and virtually all, photoconductive switches is current filamentation. This is clearly seen during the operation of the switch at high power, where "hot spots" are visible at the contact edges. These hot spots, which occur primarily at the anode contact in our n-i-n devices, are an indication of localized, high current density channels ablating the contact edge. Optical microscopy also reveals molten "channels" through the bulk of the material. These channels have dimensions on the order of 0.05 to 0.2 mm across. If we assume that the filament is circular and use the nominal values of 0.1 mm and a current of 80 A, we get a current density of approximately 1×10^6 A/cm². These current densities may also be made higher when a coplanar contact geometry is used. The reason for this is that there tends to be significant current crowding at the edge of the contact [15].

A possible initiating mechanism for current filamentation whereby a high field is developed at the anode contact depletion region in a n-i-n structure is discussed in ref. 11. Specifically, Shockley [16] in the early 1960's, postulated a possible initiation mechanism for microplasma (filamentary) breakdown in the high-field depletion regions of silicon diodes. In this mechanism, a structural imperfection containing traps which can immobilize high densities of charge, increases the local electric field. These localized fields can reach the values necessary for avalanche breakdown "... and provide a "lock-on" mechanism ..." [16] by inducing filamentary currents. It cannot be ruled out that the high density of traps in semi-insulating GaAs could initiate a filament through such a process. The "lock-on" mechanism described by Shockley resembles the "lock-on" effect widely reported in GaAs photoconductive switches [17].

CONCLUSION

Experiments have been conducted to investigate the scalability of the BOSS device to high powers. Our results, to date, indicate that the switch interrupted approximately 400 kW that was being delivered to a 50- Ω load. Data has also been presented which shows the interruption of currents that are not entirely the result of linear, persistent photoconductivity (Fig. 4). Whether the optical-quenching mechanism has the capability of turning off currents that are filamentary in nature (lock-on currents), has yet to be determined. It is our goal to design and develop a BOSS device which will operate at high powers in the linear mode.

Our efforts have demonstrated that the BOSS switch has the potential to operate multi-megawatt power levels. There are, however, some practical and theoretical issues that must be addressed before the power scaling effort will be successful. One important issue is the time scales over which the switching event occurs. This includes the bias pulse width, the laser pulse width, and the time that the BOSS switch remains in conduction. Work is now in progress to reduce the bias pulse to less than a microsecond, and procure a subnanosecond laser. Operating on reduced time scales will increase the power-handling capability of the switch by minimizing power dissipation in the bulk of the device. Work is also being done to reduce the on-state resistance by optimizing bulk compensation process. This includes investigations into the bulk uniformity both before and after compensation. By reducing both the conduction times and the on-state resistance, some of the thermal mechanisms observed in our devices should be avoided.

As a result of the damage occurring to the contacts at high power, particularly the anode contact, an

important part of our power scaling effort involves the investigation of different contact geometries and formulations. Our opinion is that the preferential damage to the anode contact results from its inability to inject the necessary holes during peak turn-on illumination to prevent the development of a high-field exclusion zone at the interface [4]. Damage to the cathode contact may occur, after the filament is formed, when the current density becomes too high to be supported by the metalization layer. Therefore, we are looking at different ways of forming both n⁺-i-n⁺ and p⁺-i-n⁺ devices both by ion implantation, and standard alloying techniques. Contact lifetime is being addressed both through better processing techniques and by looking at specific switch geometries that can reduce the current crowding effects commonly seen in planar devices.

ACKNOWLEDGEMENT

This effort was primarily funded by the Defense Advanced Research Projects Agency with additional funding from the Space and Naval Warfare Systems Command.

REFERENCES

- [1] Mourou G. and Knox W., "High power switching with picosecond precision," *Appl. Phys. Lett.*, vol. 35, p. 492, 1979.
- [2] Schoenbach, K.H., Lakdawala, V.K., Germer R. and Ko S.T., "An optically controlled closing and opening semiconductor switch," *J. Appl. Phys.*, vol. 63, p. 2460, 1988.
- [3] Mazzola, M.S., Schoenbach, K.H., Lakdawala, V.K., and Ko, S.T., "Nanosecond optical quenching of photoconductivity in a bulk GaAs switch," *Appl. Phys. Lett.*, vol. 55, p. 2102, 1989.
- [4] Mazzola M.S., Roush R.A., Stoudt D.C., and Griffiths S.F., "Evaluation of transport effects on the performance of a laser-controlled GaAs switch," to be presented at the Eighth IEEE Pulsed Power Conf., San Diego, California, June 17-19, 1991.
- [5] Blanc J., Bube R.H., and MacDonald H.E., "Properties of high-resistivity gallium arsenide compensated with diffused copper," *J. Appl. Phys.*, vol. 32, p. 1666, 1961.
- [6] Grown by Bertram Laboratories, Somerville, NJ 08876.
- [7] Roush, R.A., Mazzola, M.S., Schoenbach, K.H., and Lakdawala, V.K., "Optical quenching of lock-on currents in GaAs:Si:Cu switches," *Proc. 19th Power Mod. Symp.*, San Diego, CA, p. 339, 1990.
- [8] Mazzola, M.S., "Experimental studies of bulk optically controlled GaAs switches utilizing fast infrared quenching," Ph.D. Dissertation, Dept. of Electrical & Computer Eng., Old Dominion Univ., Norfolk, VA, 1990.
- [9] Balland, J.C., Zielinger, J.P., Tapiero, M., Gross, J.G., and Noguet, C., "Investigation of deep levels in high-resistivity bulk materials by photo-induced current transient spectroscopy: II. Evaluation of various signal processing methods," *J. Phys. D.: Appl. Phys.*, vol. 19, p. 71, 1986.
- [10] Stoudt, D.C., Mazzola, M.S., and Griffiths, S.F., "Characterization and switching study of an optically controlled GaAs switch," *Proc. SPIE*, vol. 1378, p. 280, 1990.
- [11] Mazzola, M.S., Roush, R.A., Stoudt, D.C., and Griffiths, S.F., "Analysis of non-ohmic current-voltage characteristics in a Cu-compensated GaAs photoconductor," accepted for publication in *Appl. Phys. Lett.*, 1991.
- [12] Stoudt, D.C., Schoenbach, K.H., Brinkmann, R.P., Lakdawala, V.K., and Gerdin, G.A., "The recovery behavior of semi-insulating GaAs in electron-beam-controlled switches," *IEEE Trans. Elect. Dev.*, vol. 37, p. 2478, 1990.
- [13] Stoudt, D.C., Schoenbach, K.H., Lakdawala, V.K., "The electrical characteristics of semi-insulating GaAs for high power switches," *Proc. Seventh IEEE Pulsed Power Conf.*, Monterey, CA, p. 348, 1989.
- [14] Brinkmann, R.P., Schoenbach, K.H., Stoudt, D.C., Lakdawala, V.K., Gerdin, G.A., and Kennedy, M.K., "The lock-on effect in electron-beam-controlled GaAs switches," *IEEE Trans. Elect. Dev.*, vol. 38, p. 701, 1991.
- [15] Murrmann, H. and Widmann, D., "Current crowding on metal contacts to planar devices," *IEEE Trans. Elect. Dev.*, vol. 16, p. 1022, 1969.
- [16] Shockley, W., "Problems related to p-n junctions in silicon," *Solid-State Electron.*, vol. 2, p. 35, 1961.
- [17] Loubriel, G.M., Helgeson, W.D., McLaughlin, D.L., O'Malley, Zutavern, F.J., Rosen, A., and Stable, P.J., "Triggering GaAs lock-on switches with laser diode arrays," *IEEE Trans. Elect. Dev.*, vol. 38, p. 692, 1991.