

RAILGUN EROSION SIMULATOR

Mark Johnson, Paul Cote, Frank Campo, and Pat Vottis

Benet Laboratories
Watervliet, NY 12189-4050

Abstract

The U.S. Army Armament Research, Development, and Engineering Center's Benet Laboratories is currently developing a diagnostic launcher for use as an erosion simulator to investigate issues associated with the bore life of rail guns. The launcher being developed at Benet provides a test bed for validation of new erosion concepts and serves as a facility for preliminary evaluation of candidate core materials. It has been optimized to provide details about the dominant bore erosion mechanisms observed in larger systems.

I. EROSION

There are significantly more reports in the literature regarding damage to solid armatures than erosion on rail surfaces. This is presumably because of the severity of the damage typically observed in armatures. Aluminum armatures are usually employed, offering the advantage of melt lubrication which tends to produce a "zero friction" condition. The low melting temperature of aluminum leads to more thermal damage in the armature than in the rails which are usually made of Glidcop. Persad, et al [1] studied armature-rail erosion phenomena using solid aluminum armatures; armature-rail contact was maintained all along the rail in their experiments. They observed that, upon firing, most of the rail surface became coated with a protective layer of quenched aluminum film, so no actual damage to the Glidcop rail surface was detected. It is commonly observed in rails from firing tests that erosion grooves initially form near the outer edges and gradually converge to a single central groove downbore. Cote et al. [2] discuss the erosion mechanism in the rail surface in terms of melting enhanced by contact and alloying with hot molten aluminum from the armature. The localization of the erosion into the two grooves at the rail edges and their merging into a single central groove at the downbore locations reflect a similar concentration and merging of the paths of main current through the rail and armature. At high armature velocities and at rapidly increasing currents, the back emf at the rear of the armature tends to drive the current away from the rear of the armature and towards the top and bottom. Downbore, as the current decreases with time, the

resulting transient emfs tend to drive the current to the center of the armature.

II. MODEL

A model of the launcher is being developed as an engineering design tool and to provide a means of predicting performance. It is also being used to estimate the location and energies associated with the dominant erosion mechanisms that result from the redistribution of currents in the rails and armature. The model is based on transient circuit solutions of sequentially pulsed capacitive energy sources coupled with the Lorentz forces associated with the currents in a sliding contact on parallel conductive rails. The solution of the differential equations involving the state variables associated with the linear storage elements is solved using one step methods while the behavior of nonlinear circuit elements is modeled using an iterative linear companion solution. Figure 1 shows the equivalent circuit of the launcher model for a series of switched parallel capacitor banks. Several capacitor banks are discharged in a sequence that optimizes the current/force profile in an effort to maximize the erosion effects we are trying to reproduce. The capacitance, resistance, and inductance are assumed to be identical for each bank and are given by R_1 , R_2 , and L_1 . L_2 and R_3 are common to all banks. The armature is accelerated by the current in the loop created by the linear companion model of a diode (G_{eq} , I_{eq} , and r_s) and the circuit inductance. In the equivalent circuit, $R_1 = R_{esr} + R_{busbar1} + R_{fuse}$, $R_2 = R_L$, $R_3 = R_{cable} + R_{busbar2} + R_{brech} + R_{armature} + 2R_{contact} + R_{rails}$, $L_1 = L_{bank}$, and $L_2 = L_{cable} + L_{brech} + L_{rails}$. The capacitor esr (R_{esr}) and fusing (R_{fuse}), busbar resistance (R_{busbar}), cabling (R_{cable}), pulse shaping inductor resistance (R_L), armature resistance ($R_{armature}$), contact resistance ($R_{contact}$), and brech resistance (R_{brech}) are assumed to be fixed. R_{brech} is the resistance of the length of the rail from the brech to starting location of the armature in the gun. R_{fuse} represents the parallel resistance of the capacitor fuses. The pulse shaping inductance (L_{bank}), cable inductance (L_{cable}), rail inductance from the brech to the starting location of the armature (L_{brech}) are fixed. The inductance of the busbar is assumed to be negligible. The inductance (L_{rails}) and resistance (R_{rails}) of the rails are a function of armature position.

Report Documentation Page

Form Approved
OMB No. 0704-0188

Public reporting burden for the collection of information is estimated to average 1 hour per response, including the time for reviewing instructions, searching existing data sources, gathering and maintaining the data needed, and completing and reviewing the collection of information. Send comments regarding this burden estimate or any other aspect of this collection of information, including suggestions for reducing this burden, to Washington Headquarters Services, Directorate for Information Operations and Reports, 1215 Jefferson Davis Highway, Suite 1204, Arlington VA 22202-4302. Respondents should be aware that notwithstanding any other provision of law, no person shall be subject to a penalty for failing to comply with a collection of information if it does not display a currently valid OMB control number.

1. REPORT DATE JUN 2005	2. REPORT TYPE N/A	3. DATES COVERED -	
4. TITLE AND SUBTITLE Railgun Erosion Simulator		5a. CONTRACT NUMBER	
		5b. GRANT NUMBER	
		5c. PROGRAM ELEMENT NUMBER	
6. AUTHOR(S)		5d. PROJECT NUMBER	
		5e. TASK NUMBER	
		5f. WORK UNIT NUMBER	
7. PERFORMING ORGANIZATION NAME(S) AND ADDRESS(ES) Benet Laboratories Watervliet, NY 12189-4050		8. PERFORMING ORGANIZATION REPORT NUMBER	
9. SPONSORING/MONITORING AGENCY NAME(S) AND ADDRESS(ES)		10. SPONSOR/MONITOR'S ACRONYM(S)	
		11. SPONSOR/MONITOR'S REPORT NUMBER(S)	
12. DISTRIBUTION/AVAILABILITY STATEMENT Approved for public release, distribution unlimited			
13. SUPPLEMENTARY NOTES See also ADM002371. 2013 IEEE Pulsed Power Conference, Digest of Technical Papers 1976-2013, and Abstracts of the 2013 IEEE International Conference on Plasma Science. IEEE International Pulsed Power Conference (19th). Held in San Francisco, CA on 16-21 June 2013.			
14. ABSTRACT The U.S. Army Armament Research, Development, and Engineering Centers Benet Laboratories is currently developing a diagnostic launcher for use as an erosion simulator to investigate issues associated with the bore life of rail guns. The launcher being developed at Benet provides a test bed for validation of new erosion concepts and serves as a facility for preliminary evaluation of candidate core materials. It has been optimized to provide details about the dominant bore erosion mechanisms observed in larger systems.			
15. SUBJECT TERMS			
16. SECURITY CLASSIFICATION OF:			17. LIMITATION OF ABSTRACT
a. REPORT unclassified	b. ABSTRACT unclassified	c. THIS PAGE unclassified	SAR
			18. NUMBER OF PAGES 4
			19a. NAME OF RESPONSIBLE PERSON

The voltage, $d\phi_2/dt$, across L_2 is comprised of 2 terms:

$$-\frac{d\phi_2}{dt} = -L_2 \frac{dI}{dt} - I \frac{dL_2}{dt} = -L_2 \frac{dI}{dt} - I \frac{dL_2}{dx} v \quad (1)$$

where v is the armature velocity.

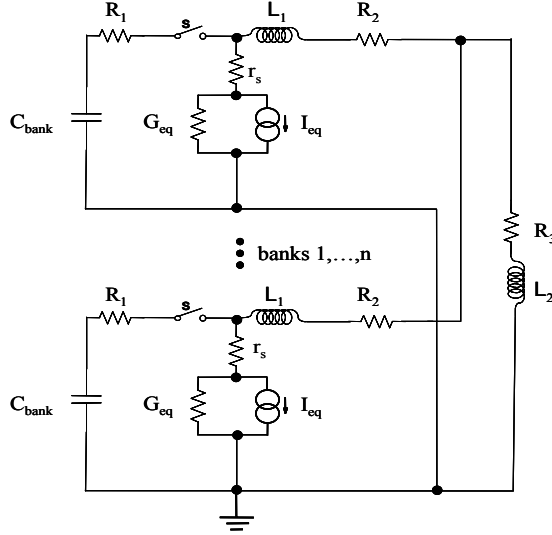

Figure 1. Equivalent circuit model of launcher for n switched capacitor banks.

Equations (2-4) represent a state space solution [3] for the system $\dot{V}_{Ck} = f(V_{Ck}, I_{Lk}, v)$, $\dot{I}_{Lk} = f(V_{Ck}, I_{Lk}, v)$, and $\dot{v} = f(V_{Ck}, I_{Lk}, v)$ where V_{Ck} is the capacitor voltage for bank k , I_{Lk} is the current in bank k , and v is the projectile velocity.

$$\dot{v} = \frac{L_p \sum_{j=1}^n I_{Lj}^2}{2m}, \text{ where } m \text{ is the projectile mass,} \quad (2)$$

$$\dot{V}_{Ck} = \frac{(V_{Ck} - V_{dpk})}{C} \text{ where } k \text{ is the bank index,} \quad (3)$$

$$\dot{I}_{Lk} = \sum_{j=1}^n \frac{(L_1(V_{dpk} - I_{Lk}(R_2 + R_3 + L_p v)) - I_{Lj}(R_3 + L_p v) + L_2(nV_{dpk} - R_2(nI_{Lk} - I_{Lj}) - V_{dpk}))}{L_1(L_1 + L_2(n+1))} \quad (4)$$

where $V_{dpk} = \frac{(V_{Ck} - I_{Lk} R_1)(G_{eqk} r_s + 1) - I_{eqk} R_1}{G_{eqk}(r_s + R_1) + 1}$, and n = the number of active banks - 1.

III. HARDWARE

Figure 2 shows a block diagram of the launcher hardware. The launcher hardware is comprised of 80, 3500 μ F, 450 V Sprague electrolytic capacitors [4]. The capacitors are separated into 4 identical banks that can be individually triggered. Power for the capacitors is derived from a LAMBDA EMI Model 402 [5] capacitor charging system coupled through a normally open Ross [6] high power relay. A second normally closed Ross relay shunts the capacitors through a 4 ohm diode to ground. The relays are controlled by an OPTO-22 [7] control system. Westcode [8] N2086NS060 SCRs and ABB [9] 5SDD 71X0400 diodes are employed. Triggering is provided by a Berkeley Nucleonics Model 555 [10] pulse generator interfaced with custom circuitry that provides optical isolation. Current is monitored using B-dot probes, highly coupled to the power supply inductors, L_1 .

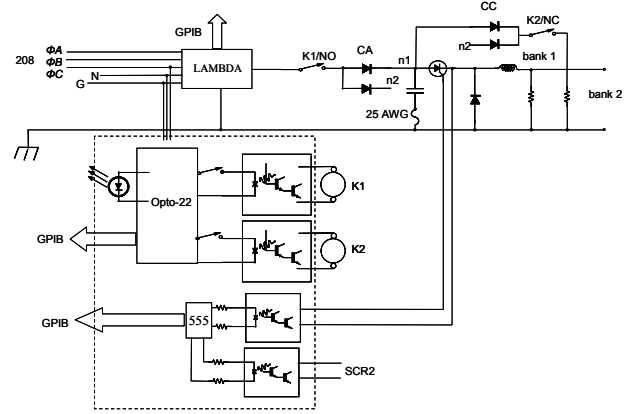

Figure 2. Block diagram of launcher.

The launcher hardware is based on a design provided by Institute for Advanced Technology in Austin, TX. The rails are 1m in length and 0.0127 m wide. The insulators are comprised of standard G10 material.

IV. RESULTS

The maximum energy of the system is 28 kJoules and proved insufficient to duplicate the rail erosion mechanisms observed in the larger systems. Therefore, the materials and power supply were optimized to reproduce the effects at lower current densities. The copper rails were coated with tin and a copper armature was employed. The capacitors were staged so that $\frac{1}{2}$ of the total energy was discharged approximately $\frac{1}{2}$ of the distance down bore to maximize the effect of the redistribution of currents.

Figures 3-7 shows the results of the MATLAB solution for (2-4) using parameters representative of Benet's erosion simulator. The values used in the simulation were measured when practical, but were generally estimates

based on the geometry and resistivity of the material. Each capacitor bank was charged to an initial voltage of 450 volts and individually triggered at 0.0 ms, 0.0 ms, 10.0 ms, and 10.0 ms. The total initial system energy was 28.4 kJoules.

Figure 3 shows that individual bank currents peak at approximately 25 kA and the maximum current through the armature is 55 kA.

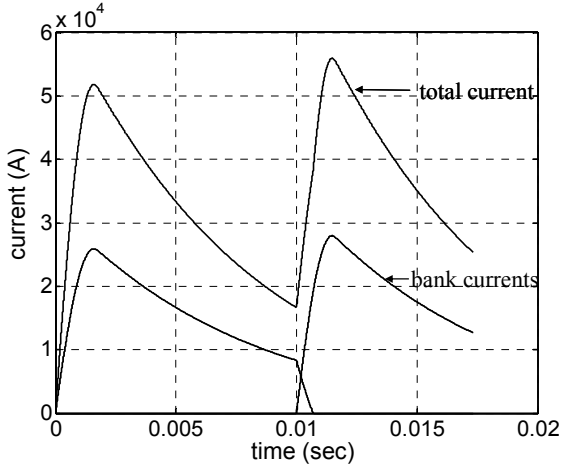

Figure 3. Predicted current history for 4 capacitor banks discharged at 0 ms, 0 ms, 10 ms, and 10 ms.

Figure 4 shows the predicted armature velocity for the 0.045 kg copper armature. The simulation predicts the projectile will exit the muzzle at 102 m/s in approximately 17 ms.

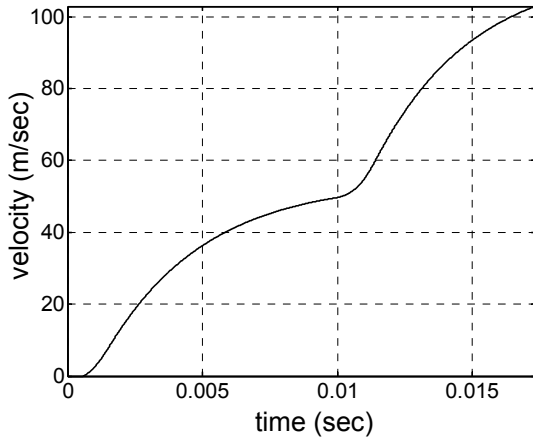

Figure 4. Predicted armature velocity.

Figure 5 gives an estimate of the approximate location of the dominant erosion tracks for the 1.27 cm, 1 meter long launcher rails using estimates of di/dt as a guide. The potential at the rear of the armature has been shown through FEMLAB [11] models to drive the current to the top and bottom of the armature, creating 2 distinct erosion tracks. The capacitor banks were discharged in a sequence to create this symmetrical distribution of current at 2

locations on the rail. The erosion tracks begin to merge approximately 1 ms after the peak current ($di/dt = 0$) based on FEMLAB models. The starting position of the armature was 0.1 m from the breech. The second 2 capacitor banks discharge after 10 ms and the model predicts 2 distinct erosion tracks from 0.46 m to 0.49 m from the breech.

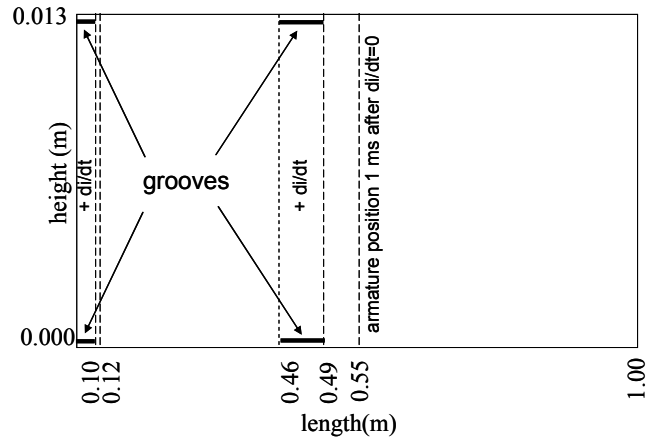

Figure 5. Estimate of rail groove locations.

Figure 6 shows estimates of both terms of $d\Phi/dt$ at the rear of the armature contributing to the distribution of armature currents. The entire motional emf appears across the rear of the armature due to concentrated flux creation. The fraction of $L_2 di/dt$ at the rear of the armature is obtained using the inductance gradient weighted by the armature width relative to the length of the exposed rails.

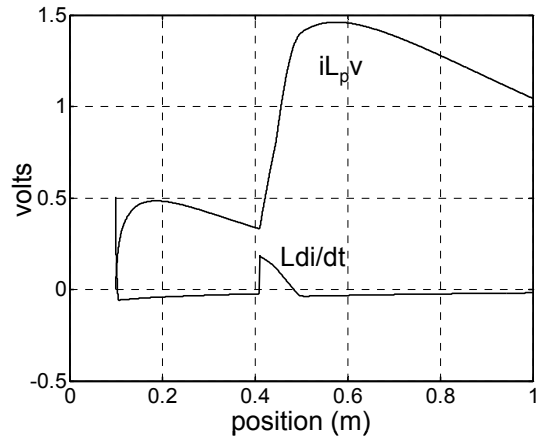

Figure 6. Estimate of potentials at the rear of the armature

The measured velocity of 103 m/s is in excellent agreement with predicted value of 102 m/s as is the rail location of the second discharge. Figure 7 shows the tin rail damage at approximately 0.6 m from the breech. The figure shows the copper located at the edges of the rail at this location. Although this result is very promising, further tests are currently underway to determine if this is actually reproducing the fundamental erosion mechanism

that occurs in larger systems. Figure 8 shows an initial result of the analysis. It shows a laser scanning confocal image typical of the material located at the edges. This suggests that the copper material is melted and not simply abraded.

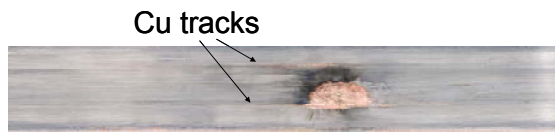

Figure 7. Tin coated copper rail showing potential edge effects at 0.6 m from breech.

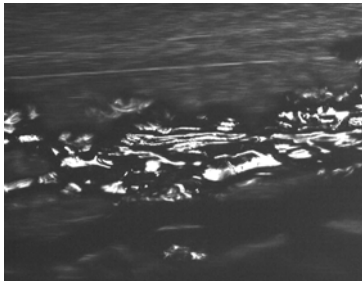

Figure 8. Laser scanning confocal image typical of the distribution of molten copper along the tracks.

V. CONCLUSIONS and SUMMARY

A diagnostic launcher is an essential tool for investigating issues associated with the bore life of rail guns. The launcher being developed at Benet provides a test bed for validation of new theory and serves as a facility for preliminary evaluation of candidate core materials. It has been optimized to provide details about the dominant bore erosion mechanisms observed in larger systems. A model of the erosion simulator is an important engineering design tool and a useful resource for providing insight into the dynamics of the system. Simulation results and preliminary experimental data suggest that dominant wear mechanisms present in larger scale launchers may be evident in the small scale erosion simulator that has been optimized to reproduce the effects. The erosion simulator promises to be a useful resource in our efforts to enhance the bore life of electromagnetic launchers.

VI. REFERENCES

- [1] C. Persad, A. Yeoh, G. Prabhu, G. White, and Z. Eleizer, "On the nature of the armature-rail interface: liquid metal effects", *IEEE Transactions on Magnetics*, vol. 33, No.1, pp 140-145, Jan 1997.
- [2] P.J. Cote, M.A. Johnson, S. B. Smith, K. Truszkowska, and P. Vottis, "Erosion mechanisms in the MCL-20 rail gun liners", internal report (in press).
- [3] L.O. Chua and P.M. Lin, "Computer-Aided Analysis of Electronic Circuits", Prentice Hall, Inc, 1975.
- [4] Commonwealth Sprague, 865 South Church Street, North Adams, MA 01247.
- [5] Lambda America, 405 Essex Road, Neptune, NJ 0775
- [6] Ross Engineering Corporation, 540 Westchester Drive, Campbell, CA. 95008.
- [7] OPTO 22, 43044 Business Park Drive, Temecula CA 92590.
- [8] Westcode Semiconductors, Langley park Way, Langley Park, Chippenham, UK.
- [9] ABB Power Systems, Power Technology Products, North Brunswick, NJ.
- [10] Berkeley Nucleonics Corporation, 2955 Kerner Road, San Rafael, CA, 94901.
- [11] COMSOL Inc, 1 New England Executive Park, Burlington, MA 01803.