

OPERATION OF HIGH-VOLTAGE TRANSVERSE SHOCK WAVE FERROMAGNETIC GENERATOR IN THE OPEN CIRCUIT AND CHARGING MODES

Sergey I. Shkuratov*¹, Evgueni F. Talantsev¹, Jason Baird¹, Larry L. Altgilbers²,
Allen H. Stults³ and Stanislav V. Kolossenok⁴

¹Loki Incorporated, Rolla, MO 65409, U.S.A.

²U.S. Army Space and Missile Defense Command, Huntsville, AL 35807, U.S.A.

³U.S. Army Research, Development and Engineering Command, Huntsville, AL 35898, U.S.A.

⁴Department of Optics, Physics Research Institute at St. Petersburg State University, Russia

ABSTRACT

Results of the investigation of the operation of explosive-driven high-voltage shock wave ferromagnetic generators (FMGs) in the open circuit and charging modes are presented. FMGs are based on the transverse (when the shock wave propagates across the magnetization vector \mathbf{M}) shock demagnetization of $\text{Nd}_2\text{Fe}_{14}\text{B}$ hard ferromagnetic energy-carrying elements of diameter 2.22 cm and length 2.54 cm (volume 8.5 cm³). In the charging mode the capacitance of capacitor banks was varied from 18 to 36 nF. The energy transferred to the capacitor bank reached 0.38 J. FMGs provided pulsed powers of 35-45 kW in times ranging from 10 to 15 μs . Computer codes were developed to digitally simulate the operation of the transverse FMG in the charging mode. Experimental results that were obtained are in a good agreement with the results of digital simulations.

I. INTRODUCTION

The generation of primary electrical power by compact autonomous sources is critical to the success of many modern scientific and engineering projects [1]. New types of autonomous primary power sources based on the demagnetization of hard ferri- and ferromagnetic materials by longitudinal and transverse shock waves generated by high explosives were recently developed [2-9]. In this paper we present the results of investigations of the operation of high-voltage ferromagnetic generators based on the transverse (when the shock wave propagates across the magnetization vector \mathbf{M}) shock wave demagnetization of $\text{Nd}_2\text{Fe}_{14}\text{B}$ hard ferromagnets. The FMGs operated in the open circuit mode and in the charging mode when the load of the generator was a capacitor bank of different capacitances. Operation of generators in the charging mode was successfully simulated with the computer codes developed by the authors.

*e-mail: Shkuratov@lokiconsult.com

Distribution A: 5147-05

II. EXPERIMENTAL

A schematic diagram and photo of a high-voltage transverse FMG are shown in Fig. 1. It contains a hollow hard ferromagnetic cylindrical $\text{Nd}_2\text{Fe}_{14}\text{B}$ energy-carrying element, a plastic pulse-generating coil holder, a multi-turn pulse generating coil, and the output high-voltage terminals.

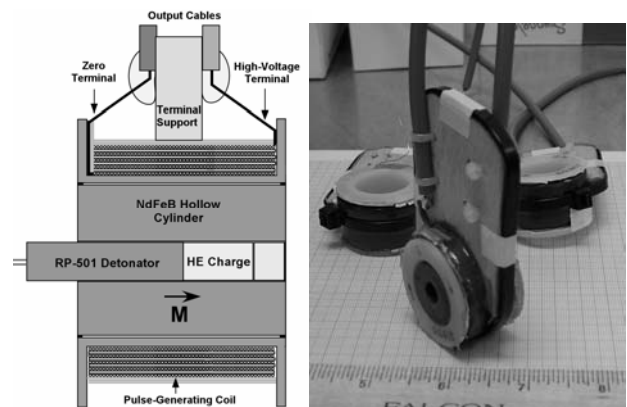

Figure 1. Schematic diagram of high-voltage transverse FMG (left) and the FMG prepared for loading high explosives (right).

All generators described in this paper contained $\text{Nd}_2\text{Fe}_{14}\text{B}$ (grade 35) energy-carrying elements of outer diameter $D = 2.22$ cm and length $h = 2.54$ cm loaded with one RP-501 detonator and 0.6 g of desensitized RDX (see Fig. 1). The inner diameter of the ferromagnets varied from 0.8 to 0.9 cm.

To test the explosive-driven pulsed power and microwave sources, we designed and constructed an experimental setup at the Rock Mechanics Explosive Research Center at the University of Missouri-Rolla. In all of our experiments, we use only commercial equipment for monitoring the pulsed signals produced by the explosive-driven systems. The explosive-driven generators tested were placed inside a detonation tank near a stainless steel side port (Fig. 2). All output cables were passed out of the tank through holes in this port.

Report Documentation Page

Form Approved
OMB No. 0704-0188

Public reporting burden for the collection of information is estimated to average 1 hour per response, including the time for reviewing instructions, searching existing data sources, gathering and maintaining the data needed, and completing and reviewing the collection of information. Send comments regarding this burden estimate or any other aspect of this collection of information, including suggestions for reducing this burden, to Washington Headquarters Services, Directorate for Information Operations and Reports, 1215 Jefferson Davis Highway, Suite 1204, Arlington VA 22202-4302. Respondents should be aware that notwithstanding any other provision of law, no person shall be subject to a penalty for failing to comply with a collection of information if it does not display a currently valid OMB control number.

1. REPORT DATE JUN 2005	2. REPORT TYPE N/A	3. DATES COVERED -	
4. TITLE AND SUBTITLE Operation Of High-Voltage Transverse Shock Wave Ferromagnetic Generator In The Open Circuit And Charging Modes		5a. CONTRACT NUMBER	
		5b. GRANT NUMBER	
		5c. PROGRAM ELEMENT NUMBER	
6. AUTHOR(S)		5d. PROJECT NUMBER	
		5e. TASK NUMBER	
		5f. WORK UNIT NUMBER	
7. PERFORMING ORGANIZATION NAME(S) AND ADDRESS(ES) Loki Incorporated, Rolla, MO 65409, U.S.A.		8. PERFORMING ORGANIZATION REPORT NUMBER	
9. SPONSORING/MONITORING AGENCY NAME(S) AND ADDRESS(ES)		10. SPONSOR/MONITOR'S ACRONYM(S)	
		11. SPONSOR/MONITOR'S REPORT NUMBER(S)	
12. DISTRIBUTION/AVAILABILITY STATEMENT Approved for public release, distribution unlimited			
13. SUPPLEMENTARY NOTES See also ADM002371. 2013 IEEE Pulsed Power Conference, Digest of Technical Papers 1976-2013, and Abstracts of the 2013 IEEE International Conference on Plasma Science. IEEE International Pulsed Power Conference (19th). Held in San Francisco, CA on 16-21 June 2013.			
14. ABSTRACT Results of the investigation of the operation of explosive-driven high-voltage shock wave ferromagnetic generators (FMGs) in the open circuit and charging modes are presented. FMGs are based on the transverse (when the shock wave propagates across the magnetization vector M) shock demagnetization of Nd2Fe14B hard ferromagnetic energy-carrying elements of diameter 2.22 cm and length 2.54 cm (volume 8.5 cm³). In the charging mode the capacitance of capacitor banks was varied from 18 to 36 nF. The energy transferred to the capacitor bank reached 0.38 J. FMGs provided pulsed powers of 35-45 kW in times ranging from 10 to 15 μs. Computer codes were developed to digitally simulate the operation of the transverse FMG in the charging mode. Experimental results that were obtained are in a good agreement with the results of digital simulations			
15. SUBJECT TERMS			
16. SECURITY CLASSIFICATION OF:			17. LIMITATION OF ABSTRACT SAR
a. REPORT unclassified	b. ABSTRACT unclassified	c. THIS PAGE unclassified	
			18. NUMBER OF PAGES 4
			19a. NAME OF RESPONSIBLE PERSON

High-voltage probes, current monitors, other measuring equipment and capacitor banks were placed outside of the detonation tank, near the port. The length of the generator's output cables did not exceed 30 cm. More information about the experimental setup for explosive pulsed power tests can be found in [11].

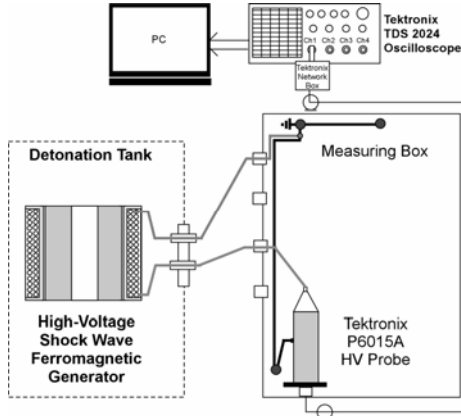

Figure 2. Schematic diagram of the measuring system for open circuit operation of the FMG.

II. OPEN CIRCUIT OPERATION OF FMG

The basis for the production of high voltage at the output terminals of the pulse-generating coil of a shock wave ferromagnetic generator is the generation of a pulse of electromotive force (*emf*), $E_g(t)$, in accordance with Faraday's law, that is related to the decrease in the initial magnetic flux in the ferromagnetic energy-carrying element due to shock wave action. For a single-turn coil the $E_g(t)$ can be determined as follows

$$E_g(t) = -d\Phi(t)/dt, \quad (1)$$

where dt is the time in which the change in the magnetic flux in the turn, $d\Phi(t)$, has taken place.

For a multi-turn coil the generated voltage is the sum of the electromotive forces produced by all the turns

$$U_g(t) = \sum_N [-d\Phi_n(t)/dt], \quad (2)$$

where $d\Phi_n(t)$ is the magnetic flux captured by n turns of the multi-turn coil, and N is the number of turns in the coil. Equation (2) is the main criteria in the design of high-voltage FMGs. The amplitude of the generated voltage is inversely proportional to the time it takes for the magnetic flux to change, and directly proportional to the number of turns in the pulse-generating coil and the value of the magnetic flux contained in each turn.

The first series of experiments was performed with high-voltage FMGs operating in the open circuit mode; the load of the generator was a high resistance (100 M Ω , 3 pF) Tektronix P6015A high-voltage probe. A schematic diagram of the measuring system for open circuit operation of the FMG is shown in Fig. 2. The high-voltage output cable of the FMG was connected directly to the HV probe. The other electrical terminal of the generator was grounded. Pulsed signals were recorded

with a Tektronix TDS2024 oscilloscope (bandwidth 200 MHz, sampling rate 2 GS/s).

The waveform of a typical high-voltage output pulse produced by an FMG in the open circuit mode is shown in Fig. 3. The generator contained a 231-turn pulse-generating coil (AWG 28 copper wire of diameter 0.35 mm). The inner diameter of the coil was 2.72 cm and the outer diameter was 3.34 cm. The serial resistance and the serial inductance of the pulse-generating coil measured by a HP 4275A Multi-Frequency LCR Meter were R_S (100 kHz) = 20.1 Ω and L_S (100 KHz) = 1.8 mH, respectively.

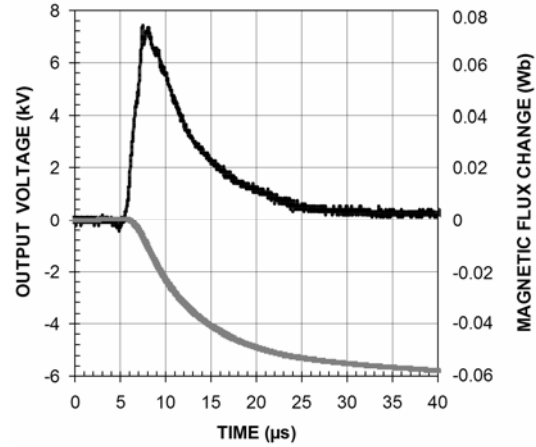

Figure 3. Waveform of the high voltage output pulse (black) produced by an FMG containing a 231-turn pulse-generating coil in the open circuit mode, and the corresponding time history of the change of magnetic flux in the generator (gray) [Eq. (3)].

The peak amplitude of the pulse is $U_g(t)_{max} = 7.45$ kV, the full width at half maximum (FWHM) is 5.8 μ s, and the risetime is $\tau = 2.6$ μ s. There is a long tail with amplitude of about 300 V. The specific peak electromotive force is $U_g(t)_{max spec} = 32.2$ V/turn.

Figure 3 also shows the time history of the magnetic flux change in the FMG, $\Delta\Phi(t)$, which was obtained by integrating the experimental waveform of the output voltage pulse

$$\Delta\Phi(t) = -\int_0^t U_g(t)dt \quad (3)$$

The final magnetic flux change is $\Delta\Phi_{fin} = 58$ mWb (Fig. 3). The specific magnetic flux change is $\Delta\Phi_{fin spec} = 251.1$ μ Wb/turn.

To determine the initial magnetic flux produced by the Nd₂Fe₁₄B energy-carrying elements, we used the ANSOFT Maxwell three-dimensional code [www.ansoft.com]. The calculated value of the average initial magnetic flux in the cross section of the pulse-generating coil is $\Delta\Phi_0 = 269.4$ μ Wb. Comparing the experimentally obtained specific magnetic flux change in the coil to the initial value of the magnetic flux one can make the conclusion that more than 90% of magnetic flux stored in the Nd₂Fe₁₄B hard ferromagnetic energy-

carrying element was transformed into the high-voltage pulse produced by the generator.

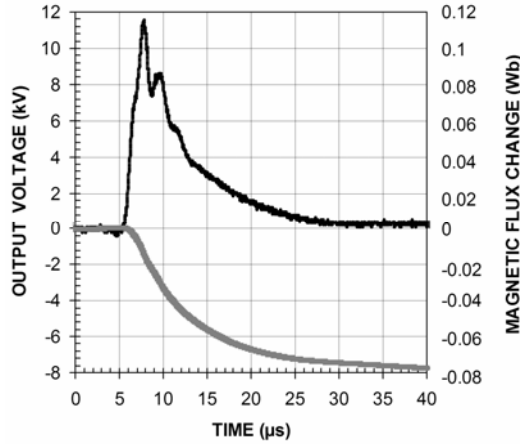

Figure 4. Waveform of the output pulse (black) produced by an FMG containing a 364-turn pulse-generating coil in the open circuit mode, and the corresponding time history of the magnetic flux change in the generator (gray) [Eq. (3)].

We performed a series of experiments with FMGs containing pulse-generating coils having turn numbers ranging from 350 to 370. The amplitudes of the FMG output pulses and their waveforms were very reproducible. The waveform of a typical high-voltage output pulse produced by an FMG containing a 364-turn pulse-generating coil (wire diameter 0.35 mm) in the open circuit mode, and the corresponding time history of the magnetic time change in the generator, are shown in Fig. 4. The inner diameter of the coil was 2.72 cm and its outer diameter was 3.88 cm. The serial resistance and serial inductance of the coil were $R_S(100 \text{ kHz}) = 43.7 \Omega$ and $L_S(100 \text{ KHz}) = 3.68 \text{ mH}$, respectively.

Increasing the number of turns in the pulse-generating coil resulted in a higher amplitude of the output high-voltage pulse, $U_g(t)_{max} = 11.55 \text{ kV}$ (FWHM = 5.38 μs , $\tau = 2.26 \mu\text{s}$). There is a long tail with amplitude of about 300 V that is similar to that shown in Fig. 3. The specific electromotive force is $U_g(t)_{max spec} = 31.7 \text{ V/turn}$. The final magnetic flux change is $\Delta\Phi_{fin} = 77.6 \text{ mWb}$. The specific magnetic flux change is $\Delta\Phi_{fin spec} = 213.2 \mu\text{Wb/turn}$.

III. DIGITAL SIMULATION OF OPERATION OF FMG

We developed the methodology for simulating the operation of high-voltage shock wave ferromagnetic generators using the Pspice commercial code. This methodology is based on the integrated normalized electromotive force [8, 9].

After obtaining experimental data on the operation of high-voltage FMGs in the open circuit mode we performed a series of simulations of the generator

operation in the charging mode, in order to predict the amplitude of the high-voltage and current pulses, and to derive the correct setup for the next series of experimental shots.

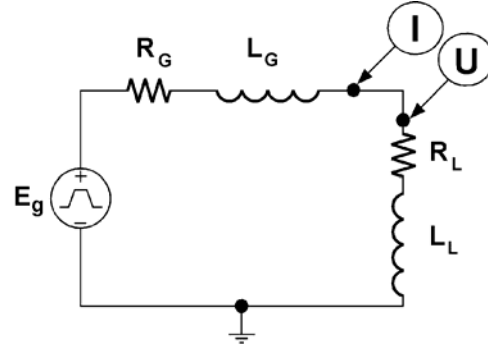

Figure 5. Equivalent circuit diagram of the FMG employed in the simulation.

The equivalent electrical circuit of the FMG employed in the simulations is shown in Fig. 5. It contains the pulsed electromotive force, E_g , the inductance, L_G , and the resistance, R_G , of the pulse-generating coil, the inductance, L_L , and the resistance, R_L , of the load, and the capacitance of the capacitor bank, C_L , connected in series. The circuit also contains the probes that measure the current $I(t)$ in the system and the voltage across the capacitor $U(t)$ (I Probe and U Probe, respectively). The normalized electromotive force was digitized and introduced into the Source section of the code.

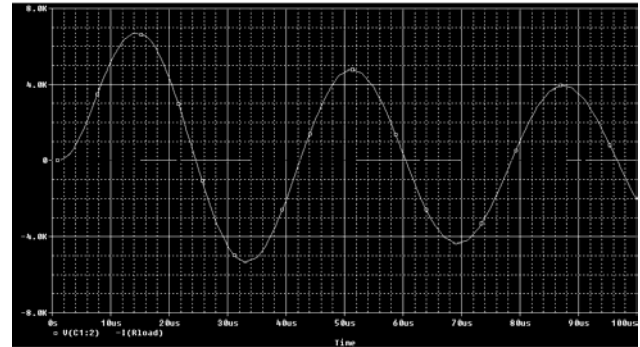

Figure 6. Calculated waveform of high voltage generated by an FMG connected to an 18 nF capacitor bank.

Figure 6 shows an example of the simulation results. It is the calculated waveform of the high voltage across a capacitor bank of capacitance $C_L = 18 \text{ nF}$ produced by an FMG containing a pulse-generating coil with 231 turns. The $L_G(100 \text{ KHz}) = 1.8 \text{ mH}$ and the $R_G(100 \text{ KHz}) = 20.0 \Omega$. The amplitude of the calculated high voltage pulse is 6.6 kV. The high-voltage pulse risetime is 16 μs . The calculated current amplitude ranges from 10 to 14 A. We performed a simulation of all configurations of FMG experimental configuration planned for the explosive tests.

IV. OPERATION OF FMG IN THE CHARGING MODE

The schematic circuit diagram for an FMG operating in the charging mode is shown in Fig. 7. The high-voltage output cable of the FMG was connected to the high-voltage terminal of the capacitor bank. The high voltage across the capacitor bank was monitored by a Tektronix P6015A high voltage probe. The pulsed current was measured by a Pearson Current Monitor (Model 101).

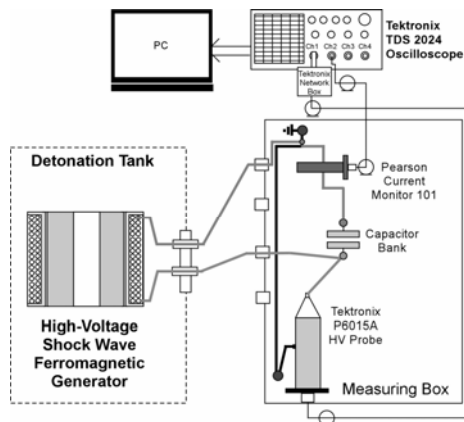

Figure 7. Schematic diagram of the measuring system for an FMG operating in the charging mode.

The waveform of the high voltage pulse produced by an FMG containing a 252-turn pulse-generating coil (wire diameter 0.35 mm) across the 18 nF capacitor bank is shown in Fig. 8. The amplitude of the voltage pulse was 6.5 kV and its risetime was 15.2 μ s. There is very good agreement between the results of the digital simulation (see Section III) and the experimental data. The energy delivered to the capacitor bank was 0.38 J. The corresponding pulses of current, voltage and power for this experiment are shown in Fig. 9. The peak power reached 43 kW.

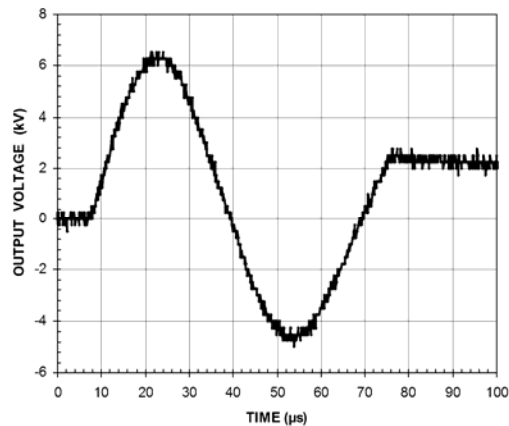

Figure 8. Waveform of the output voltage pulse produced by an FMG connected to an 18 nF capacitor bank. The pulse-generating coil contained 252 turns.

V. SUMMARY

Reliable and controllable operation of autonomous high-voltage explosive-driven generators utilizing transverse shock wave demagnetization of $\text{Nd}_2\text{Fe}_{14}\text{B}$ hard ferromagnets has been demonstrated. The FMG design developed for these experiments provides more than 50 μ s of life-time. It was shown that it is fundamentally possible to pulse charge a capacitor bank with a high-voltage transverse shock wave ferromagnetic generator. The methodology for digital simulation of the operation of a high-voltage FMG in the charging mode was developed and validated.

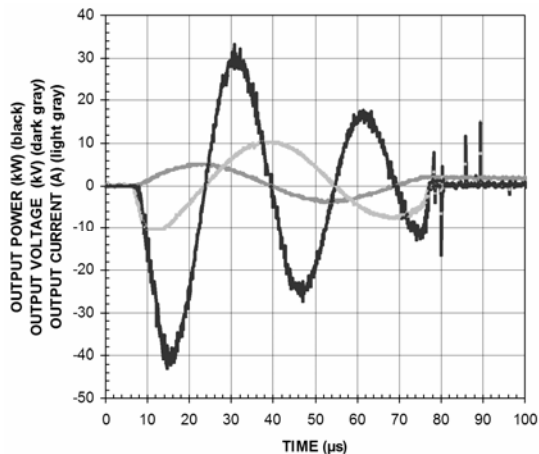

Figure 9. The current (light gray), voltage (dark gray) and power (black) waveforms produced by the FMG across an 18 nF capacitor bank. The pulse-generating coil contained 252 turns.

VI. REFERENCES

- [1] L.L. Altgilbers et al, Magnetocumulative Generators (Springer-Verlag, 2000).
- [2] S.I. Shkuratov, E.F. Talantsev, J.C. Dickens, and M. Kristiansen, *J. Appl. Phys.*, vol. 91, p. 3007, (2002).
- [3] S. I. Shkuratov, E.F. Talantsev, J.C. Dickens, and M. Kristiansen, *J. Appl. Phys.*, vol. 92, p. 159, (2002).
- [4] S.I. Shkuratov, E.F. Talantsev, J.C. Dickens, and M. Kristiansen, *Rev. Sci. Instrum.*, vol. 73, p. 2738, (2002).
- [5] S.I. Shkuratov, E.F. Talantsev, and M. Kristiansen, *IEEE Trans. on Plasma Sci.*, vol. 30 (no. 5), 1681 (2002).
- [6] E.F. Talantsev, S.I. Shkuratov, J.C. Dickens, and M. Kristiansen, *Rev. Sci. Instrum.*, vol. 74, p. 225, (2003).
- [7] S.I. Shkuratov, E.F. Talantsev, M. Kristiansen, and J. Baird, *App. Phys. Lett.*, vol. 82, p. 1248, (2003).
- [8] S.I. Shkuratov and E.F. Talantsev, *J. Electromagnetic Phenomena*, vol. 3 (no. 4(12)), p. 452, (2003).
- [9] S.I. Shkuratov, E.F. Talantsev, J.C. Dickens, and M. Kristiansen, *J. Appl. Phys.*, vol. 93, p. 4529, (2003).
- [11] S.I. Shkuratov, Baird, F. Rose, Z. Shotts, E.F. Talantsev, L.L. Altgilbers, A.H. Stults, and S.V. Kolossenok, Present Proceedings.