

EVALUATION OF COMMERCIALY AVAILABLE IGNITRONS  
AS HIGH-CURRENT, HIGH-COULOMB TRANSFER SWITCHES\*

R. Kihara  
University of California  
Lawrence Livermore National Laboratory  
P. O. Box 808, Livermore, CA 94550

Introduction

New or improved switches are needed to meet the power requirements of multimegajoule glass laser Inertial Confinement Fusion (ICF) systems and Strategic Defense Initiative (SDI) weapons (e.g., mass drivers, railguns, and high-powered pulse lasers).<sup>1,2</sup> These devices must switch high peak currents ( $>1 \times 10^6$  A) and voltages ( $>20$  kV), with an initial rate of current rise ( $di/dt$ ) greater than  $15 \text{ kA}/\mu\text{s}$ , while transferring large quantities of charge ( $>10^3$  C/pulse). The generated pulse will typically have a pulse width of 0.5 to 1.0 ms, measured at the Full-Width Half-Maximum (FWHM) or the 50% amplitude points of the waveform. The simultaneous attainment of these parameters in a repeatable switch, has to our knowledge not yet been attained.

A switch testing facility to proof and/or develop the required switches was built at the Lawrence Livermore National Laboratory (LLNL). The primary goal of this facility is to demonstrate repetitive, and simultaneous switching of 1-MA, and 1,000-C per pulse, from either commercial or LLNL-designed switches.

The published or advertised ratings for several types of high-current switches, which were considered for testing, are listed in Table 1, these are: the size "D" and "E" ignitrons, the metal-to-metal contact switch, the moving-arc switch, and a heavy-duty spark gap of conventional design. All of these switches can be operated

Table 1. Published or advertised ratings of various types of high-current switches.<sup>a</sup>

Switch	Voltage (kV)	Peak current (kA)	Coulomb/pulse	Conduction time (ms)
Ignitron				
GL-8205 <sup>b</sup>	25	600	325	<10
NL-5553 <sup>c</sup>	10	95	1,150	~30
Metal-to-metal contact switch <sup>d</sup>	25	1,000+	55	<0.2
Spark gap <sup>e</sup>	80	255	57	--
Moving arc <sup>f</sup>	80	150	12	0.040

a All switches can be operated repetitively except the metal-to-metal contact switch.  
b Manufacturer's specifications for GL-8205.  
c LANL.  
d Aldermaston AWRE.  
e Physics International.  
f MLI SREMP.

repetitively, except for the metal-to-metal contact switch, which is destroyed during the switching process. Of the remaining three switches the size "E" ignitron was chosen for the initial investigation because of its applicability to the laboratory's ICF program, and our belief based upon performance data for the smaller size "D" tubes<sup>3,4</sup> that it had the greatest potential for development.

The cross-section of an ignitron is shown in Fig. 1, and a photograph of two size "E" tubes are shown in Fig. 2. The size "E" tube packages tested are approximately 23 cm in diameter by 56 cm long, and weighed 23 to 32 kg, depending on the tube model. The tube body is typically stainless-steel and is equipped with an integral water jacket for cooling. The cathode of the tube is formed by the body in combination with the mercury pool under the anode. In normal operation, conduction occurs preferentially between the anode, which is composed of graphite or molybdenum, and the mercury pool. Almost no current should flow to the stainless-steel walls. When the ignitron is in the off-state, the space between the two electrodes is insulated by a vacuum, allowing the

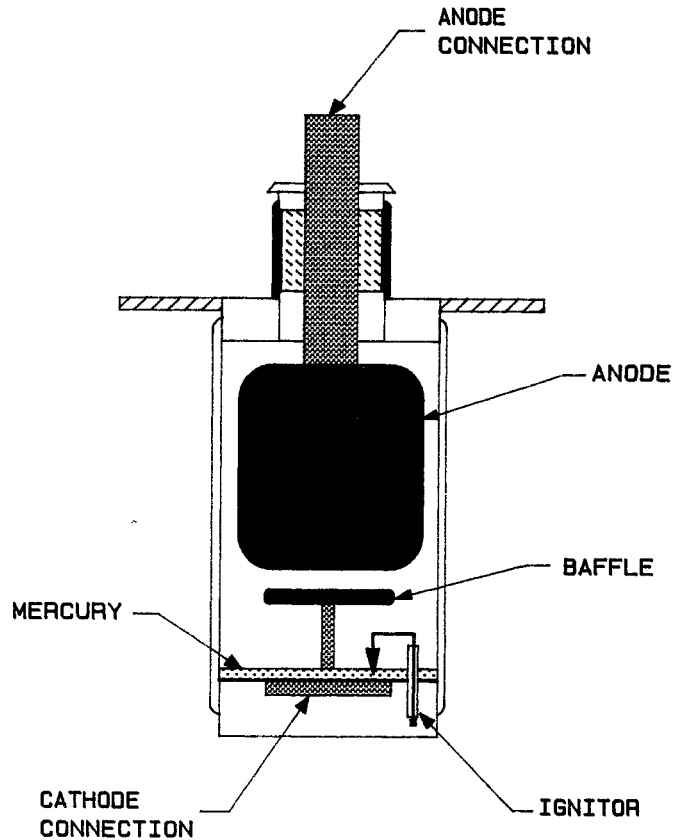

Figure 1. Cross-section of an ignitron.

\* Work performed under the auspices of the U.S. Department of Energy by the Lawrence Livermore National Laboratory under contract number W-7405-ENG-48.

# Report Documentation Page

Form Approved  
OMB No. 0704-0188

Public reporting burden for the collection of information is estimated to average 1 hour per response, including the time for reviewing instructions, searching existing data sources, gathering and maintaining the data needed, and completing and reviewing the collection of information. Send comments regarding this burden estimate or any other aspect of this collection of information, including suggestions for reducing this burden, to Washington Headquarters Services, Directorate for Information Operations and Reports, 1215 Jefferson Davis Highway, Suite 1204, Arlington VA 22202-4302. Respondents should be aware that notwithstanding any other provision of law, no person shall be subject to a penalty for failing to comply with a collection of information if it does not display a currently valid OMB control number.

1. REPORT DATE <b>JUN 1987</b>		2. REPORT TYPE <b>N/A</b>		3. DATES COVERED <b>-</b>	
4. TITLE AND SUBTITLE <b>Evaluation Of Commercially Available Ignitrons As High-Current, High-Coulomb Transfer Switches</b>				5a. CONTRACT NUMBER	
				5b. GRANT NUMBER	
				5c. PROGRAM ELEMENT NUMBER	
6. AUTHOR(S)				5d. PROJECT NUMBER	
				5e. TASK NUMBER	
				5f. WORK UNIT NUMBER	
7. PERFORMING ORGANIZATION NAME(S) AND ADDRESS(ES) <b>University of California Lawrence Livermore National Laboratory P. O. Box 808, Livermore, CA 94550</b>				8. PERFORMING ORGANIZATION REPORT NUMBER	
9. SPONSORING/MONITORING AGENCY NAME(S) AND ADDRESS(ES)				10. SPONSOR/MONITOR'S ACRONYM(S)	
				11. SPONSOR/MONITOR'S REPORT NUMBER(S)	
12. DISTRIBUTION/AVAILABILITY STATEMENT <b>Approved for public release, distribution unlimited</b>					
13. SUPPLEMENTARY NOTES <b>See also ADM002371. 2013 IEEE Pulsed Power Conference, Digest of Technical Papers 1976-2013, and Abstracts of the 2013 IEEE International Conference on Plasma Science. Held in San Francisco, CA on 16-21 June 2013. U.S. Government or Federal Purpose Rights License</b>					
14. ABSTRACT					
15. SUBJECT TERMS					
16. SECURITY CLASSIFICATION OF:			17. LIMITATION OF ABSTRACT <b>SAR</b>	18. NUMBER OF PAGES <b>4</b>	19a. NAME OF RESPONSIBLE PERSON
a. REPORT <b>unclassified</b>	b. ABSTRACT <b>unclassified</b>	c. THIS PAGE <b>unclassified</b>			

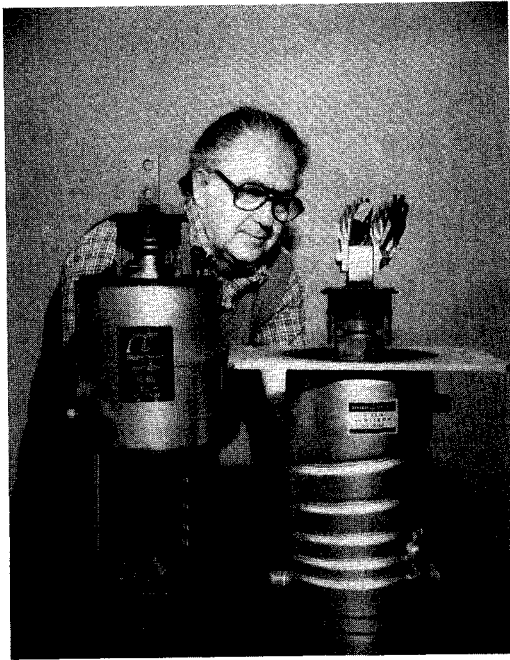

Figure 2. Photograph of (left) an NL-496 and (right) a GL-8205, size "E" ignitrons.

tube to hold off the applied voltage. The tube is switched on by applying a triggering pulse to the ignitor electrode, which is immersed in the mercury pool. A discharge forms between the mercury pool and the ignitor, filling the gap between the electrodes with ionized mercury vapor. Once the gap is filled, the mercury vapor supplies the medium for conduction, thereby switching the tube on.

#### Test Circuit Description

The test circuit was built around a large capacitor bank (56 mF @ 5 kV), rated at 700 kJ, 280 C, and 1-MA peak current, that had formerly been used for railgun studies. The circuit has two different configurations for testing switches. In the first configuration, the test circuit is operated as a critically damped RLC circuit. The charge transfer is limited by the storage capacity of the bank, or 280 Coulombs. A typical discharge waveform is shown in Fig. 3. All ignitrons to date were tested in this configuration. In the second configuration, parallel discharge circuits charge an inductor, which is crowbarred by the switch under test at peak current. This traps a slowly decaying, circulating current in both the inductor and the tube. The charge transfer is controlled by varying the L/R time constant of the inductor. For typical circuit values this can be greater than 1,000 Coulombs.

#### Test Limitations

The test results and conclusions presented here should be considered tentative, as only two to three samples of each tube type were available for testing. Each sample within types was subjected to a different test, although corresponding pairs between types were tested identically, as described below. Characterization was complicated by the fact that samples in each type often varied markedly in their behavior under identical test conditions.

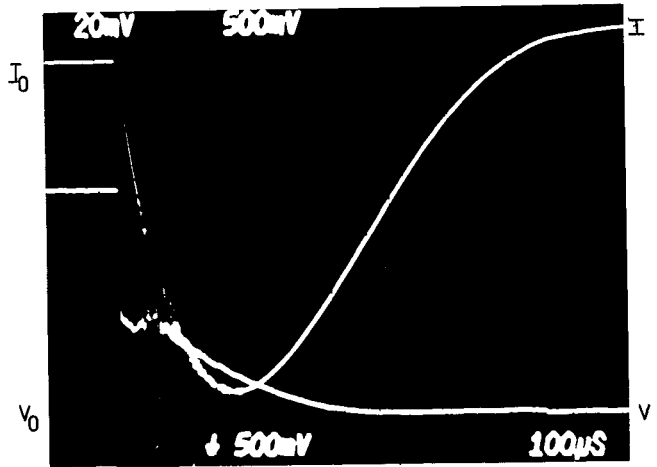

Figure 3. Typical ignitron waveforms showing current (top) and voltage drop across the tube. Shot #400 on an NL-496: top (current) 50 kA/div, bottom (voltage) 500 V/div. Sweep rate is 100  $\mu$ s/div.

#### Test Procedures

All tubes were radiographed before testing to examine the internal geometry, and to check for mechanical problems which might predispose the tube to failure. After radiography each tube was mounted in the test stand and fired down at 25-100 kA to check for proper operation. Because of the limited number of samples the following test strategy was adopted.

The "maximum current" level, which was defined as the current level required to cause failure in 1-5 shots, was the first parameter to be determined for each tube. Starting at 150 kA for all tube types, the current level was stepped-up in increments of 50-75 kA, 5-shots were to be taken at each level until either tube failure occurred, or until the test limit (1-MA and 1,000 C/shot) was reached. Once the test limit was reached, lifetesting would have started at this level. If tube failure occurred before the desired current and charge level was reached, a second tube was installed and lifetested at 60% of the "maximum current" level.

A tube failure was defined as either a failure to fire when triggered or a failure to hold voltage. A failure to fire caused by a shorted ignitor(s) was not counted as a failure if the ignitors could be cleared, by discharging a 12  $\mu$ F, 6 kV pulser through it in the forward direction.

The GL-37207a and the NL-496 were mounted in coaxial current returns, the GL-8205 was tested using the tube wall as a current return.

#### Results

None of the size "D" or "E" tubes tested survived the maximum current test. The General Electric GL-8205 failed at 525 kA, 168 C/shot (1-shot), and the National NL-496 failed at 475 kA, 151 C/shot (3-shots). The General Electric GL-37207a, a size "D" tube, reached 475 kA, 168 C/shot (6-shots). Failure of both "E" size tubes was caused by permanently shorted ignitors, both tubes still high-potted > 25 kV. The anode of the GL-37207a was deflected ( $\sim 10^\circ$ ) off of the tube axis by magnetic forces, after the

sixth shot. This was categorized as a failure, although the tube was still functional.

Since all three of the tubes tested failed at similar levels, the current level for the lifetest was set to 300 kA. The GL-8205, which has a single ignitor, survived 500-shots at this level (112 C/shot). Ignitor shorts were cleared twice during the test after shots #52 and #129. The current on the same tube was then raised to 425 kA, where the ignitor failed permanently after two shots. The NL-496 has two ignitors, and survived 435 shots (101 C/shot) before both ignitors failed. The first ignitor short occurred at shot #161, no attempt was made to clear it, and triggering was transferred to the second ignitor. After the failure of the second ignitor, neither ignitor could be cleared. Both size "E" tubes high-potted to  $\geq 25$  kV after the completion of testing. The GL-37207a has two ignitors, and survived 250 shots (102 C/shot, before failure of the glass seal. The first ignitor short occurred at shot #155, triggering was then transferred to the second ignitor.

The instantaneous arc drop was measured at the peak of the current waveform where the inductive component was zero. The variation of arc drop as a function of current was taken from the maximum current test, and is plotted in Figs. 4a,b,c. The statistical variation at one value of peak current was measured during the lifetest. For the GL-8205 @ 300 kA, this was 210-420 V for the first 50-shots, and 375-560 V, during the remainder of the test, varying widely from shot-to-shot. The mean voltage drop for 77 traces was 454 V, and the 2-sigma variation was 379-529 V. This corresponds to a tube resistance of 1.3-1.8 m $\Omega$  over one standard deviation. The drop for the NL-496 @ 300 kA was 190-375 V over the duration of the test. The mean for 27 traces was 258 V, and the 2-sigma spread was 218-297 V, for a tube resistance of

0.7-1.0 m $\Omega$  over one standard deviation. The drop for the GL-37207a (size "D") @ 300 kA was 190-260 V over the test. The mean voltage drop for 24 traces was 227 V, and the 2-sigma spread was 211-243 V. This corresponds to a tube resistance of 0.7-0.8 m $\Omega$  over one standard deviation. This data has been summarized in Table 2.

### Conclusions

Ignitor failure is presently the limiting factor in the high-current operation of the size "E" ignitrons. All of tubes tested showed a rapid drop in ignitor resistance with time. Without the use of a high energy pulser to clear the ignitors, the tube lifetimes given in this report would have been substantially shorter.

The performance of the size "E" ignitrons was disappointing in comparison to the performance of the size "D," as the specifications of the "E" size, along with their greater physical size and mass, would tend to imply a similarly scaled capacity. Although the lifetested size "D" tube survived half as long as the size "E" tubes, the failure was mechanical in nature, and had the tube been physically stronger, we feel it would have matched the size "E" tubes in performance.

Little effort has been made to re-examine the design of the ignitron, since it was invented in 1930's, except for a sporadic effort in the late fifties through mid-sixties.<sup>5,6</sup> It may be possible with new geometries, and a better understanding of the physics involved, to greatly expand it's capabilities.

### Acknowledgments

The author would like to thank D. B. Cummings for his advice on the testing of ignitrons, and K. S. Leighton who provided the technical support required to make the test facility operational.

Table 2. Summary of test results.

Ignitron	Voltage (kV)	Peak current (kA)	Maximum current (kA)	Charge		No. of shots	Tube drop (V)	Tube condition	di/dt (kA/ $\mu$ s)
				transfer/shot (C)	Pulse width (ms)				
GL-8205 (size "E")									
Maximum ratings	25	600	---	375	10	--	--	--	--
Test results:									
Maximum current <sup>a</sup>	3	--	525	168	0.32 <sup>c</sup>	1	514	failed	7.5
Lifetime <sup>b</sup>	2	300	--	112	0.36 <sup>c</sup>	500	454 <sup>d</sup>	failing	3.5
NL-496 (size "E")									
Maximum ratings	25	100	--	400	<150	--	--	--	2.0
Test results:									
Maximum current <sup>a</sup>	3	--	475	168	0.36 <sup>c</sup>	2	470	failed	6.25
Lifetime <sup>b</sup>	1.85	300	--	104	0.40 <sup>c</sup>	435	258 <sup>d</sup>	failed	3.5
GL-37207a (size "D")									
Maximum ratings	25	300	--	50	0.7	--	--	--	--
Test results:									
Maximum current <sup>a</sup>	2.7	--	475	168	0.36 <sup>c</sup>	6	300	failed	6.25
Lifetime <sup>b</sup>	1.8	300	--	102	0.36 <sup>c</sup>	250	227 <sup>d</sup>	failed	7.5

<sup>a</sup>The maximum current test determines the current level that causes tube failure in less than 5 shots.

<sup>b</sup>The lifetime test determines the tube lifetime at 60% of the maximum current level.

<sup>c</sup>Pulse width was measured at half maximum.

<sup>d</sup>Average tube drop at 300 kA.

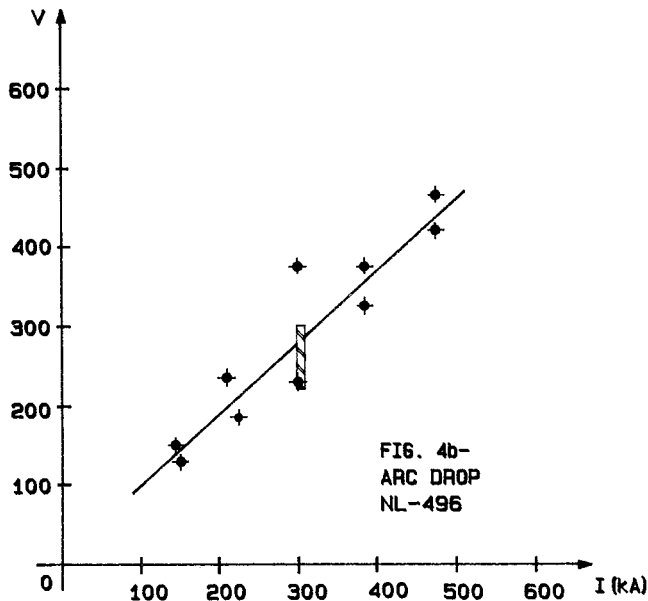
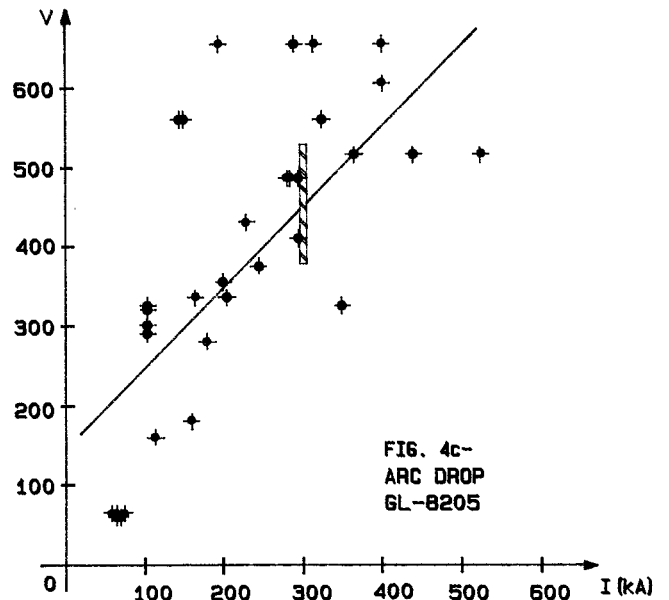
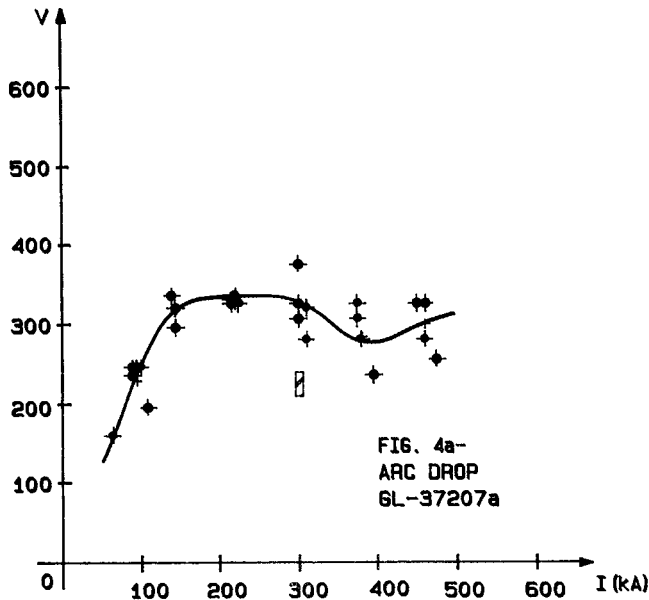

References

- [1] V. Bailey, P. Champney, J. Fockler, I. Smith, "Review of Switch Candidates and Preliminary Design of a Switch Test Facility for the Zeus Capacitor Bank," Report no. PSI-FR-154-02, January 1985, Pulse Sciences Inc., 14796 Wicks Blvd, San Leandro, Calif. 94577.
- [2] R. S. Hawke and J. K. Scudder, "Magnetic Propulsion Railguns: Their Design and Capabilities," Lawrence Livermore National Laboratory, UCRL-82677, May 8, 1979.
- [3] K. Witham, D. Larson, B. Merritt, D. Christie, "Nova Pulse Power Design and Operational Experience," Lawrence Livermore National Laboratory, UCRL-95051, January 1987.
- [4] Private Communication, J. Melton, Summary of CTR experience with ignitrons at Los Alamos National Laboratory.
- [5] D. B. Cummings, "A Stabilized Switching Ignitron," Lawrence Livermore National Laboratory, UCRL-7391, published as "A Stabilized Ignitron," IEEE Transactions on Nuclear Science, NS-11, No. 1, January 1964.
- [6] G. P. Boicourt and E. L. Kemp, "Development of Reliable 20 kV Ignitrons for Thermonuclear Research," Los Alamos Scientific Laboratory Report-LAMS-2416, December 1959.

Figures 4a,b,c. Arc drop plotted against instantaneous current for the GL-37207a, NL-496, and GL-8205. The shaded bars represent the 2-sigma variation in drop recorded during the lifestest of each tube.