

SWITCHING DEVICES USED IN THE LETHALITY TEST SYSTEM*

W. M. Parsons
Los Alamos National Laboratory
Los Alamos, NM 87545

R. D. Ford
Naval Research Laboratory
Washington, DC 20375

P. Wildi
University of Texas
Austin, TX 78712

P. Chowdhuri
Tennessee Technological University
Cookeville, TN 38505

Abstract

The Lethality Test System (LTS) is an experiment which will utilize a light gas gun-railgun combination to accelerate projectiles for impact studies. The power supply for the railgun consists of an 80 MJ (kinetic) generator-flywheel array used to charge the primary windings of three cryogenic pulse transformers. The secondary windings of these transformers will supply up to 50 MJ of electrical energy to the railgun. A number of special switching devices will be required to cause energy transfer and compression. This paper describes the design and testing of these switching devices.

Switches on the primary side of the transformers include three arrays of 3-series x 2-parallel vacuum interrupters. Each of these arrays interrupts 50 kA at 50 kV and includes a capacitor bank for commutation, two saturable reactors to provide current sharing, and an arrangement of zinc oxide varistor disks to absorb switching losses. Also on the primary are specially designed mechanical dump switches capable of 100 kV open-state standoff and 50 kA conduction with a total action of $2 \times 10^{10} \text{ A}^2\text{s}$. Contact engagement occurs within 11.2 ms after command. The third type of primary switch is an explosively-actuated 100 kV, isolation switch. The switch opens under no current and protects the equipment on the primary side of the first transformer from high transient voltages. A fourth type of switch is used both to initiate generator discharge and to crowbar the primary winding of each transformer. It consists of a modified rocker switch commonly used in the electrorefining industry. This switch must carry 50 kA for several seconds and withstand 1.4 kV in the open state. Contact initiation occurs 85 ms after command.

Switches on the secondary side of the transformers include three explosively-actuated "make before break" switches. These switches operate from a single command and cause a current-carrying fuse segment to be connected to the railgun just prior to current interruption by the fuse. Also on the secondary are seven, high-current, mechanical make switches. These switches must withstand 10 kV in the open state and conduct up to 925 kA for 10 ms. Four of the seven switches are used as secondary dump switches and must conduct 500 kA with an action of $5 \times 10^{10} \text{ A}^2\text{s}$. Contact engagement occurs within 10 ms after command. An explosively-actuated make switch will be used as a muzzle crowbar switch.

*This work is supported by the U.S. Army Strategic Defense Command and the Department of Energy.

Introduction

The Lethality Test System (LTS), presently under construction at Los Alamos, is an electromagnetic launcher facility designed to perform impact experiments at velocities up to 15 km/s.¹ The launcher is a 25 mm round bore, plasma armature railgun extending 22 m in length. Preinjection is accomplished with a two-stage light gas gun capable of 7 km/s.¹ The railgun power supply utilizes traction motors, vacuum interrupters, and pulse transformers.² An assembly of 28 traction motors, equipped with flywheels, stores approximately 80 MJ at 92% of full speed and energizes the primary windings of three pulse transformers at a current of 50 kA. At peak current an array of vacuum interrupters disconnects the transformer primary windings and forces the current to flow in the secondary windings. The secondary windings are connected to the railgun and deliver a peak current of 1.3 MA at 10 kV.

System Operation

A simplified schematic of the LTS system is shown in Fig. 1.

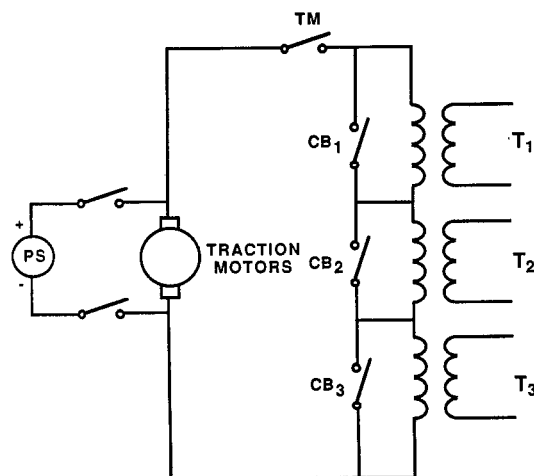

Fig. 1. Simplified LTS circuit diagram.

The system operates as follows: when the traction motor/flywheel sets have been motored to a preset speed, traction motor switch, TM, closes. The motors, acting as generators, produce a sinusoidal current rise in the transformer primaries, $T_1 - T_3$. A peak current of 50 kA is reached in 2.7 s, and crowbar switches, $CB_1 - CB_3$ are closed. This action traps the discharge current in each of the three transformer primaries. Each transformer and its associated switches are known as an energy storage and switching module (ESSM).

Report Documentation Page

Form Approved
OMB No. 0704-0188

Public reporting burden for the collection of information is estimated to average 1 hour per response, including the time for reviewing instructions, searching existing data sources, gathering and maintaining the data needed, and completing and reviewing the collection of information. Send comments regarding this burden estimate or any other aspect of this collection of information, including suggestions for reducing this burden, to Washington Headquarters Services, Directorate for Information Operations and Reports, 1215 Jefferson Davis Highway, Suite 1204, Arlington VA 22202-4302. Respondents should be aware that notwithstanding any other provision of law, no person shall be subject to a penalty for failing to comply with a collection of information if it does not display a currently valid OMB control number.

1. REPORT DATE JUN 1987	2. REPORT TYPE N/A	3. DATES COVERED -	
4. TITLE AND SUBTITLE Switching Devices Used In The Lethality Test System		5a. CONTRACT NUMBER	
		5b. GRANT NUMBER	
		5c. PROGRAM ELEMENT NUMBER	
6. AUTHOR(S)		5d. PROJECT NUMBER	
		5e. TASK NUMBER	
		5f. WORK UNIT NUMBER	
7. PERFORMING ORGANIZATION NAME(S) AND ADDRESS(ES) Los Alamos National Laboratory Los Alamos, NM 87545		8. PERFORMING ORGANIZATION REPORT NUMBER	
9. SPONSORING/MONITORING AGENCY NAME(S) AND ADDRESS(ES)		10. SPONSOR/MONITOR'S ACRONYM(S)	
		11. SPONSOR/MONITOR'S REPORT NUMBER(S)	
12. DISTRIBUTION/AVAILABILITY STATEMENT Approved for public release, distribution unlimited			
13. SUPPLEMENTARY NOTES See also ADM002371. 2013 IEEE Pulsed Power Conference, Digest of Technical Papers 1976-2013, and Abstracts of the 2013 IEEE International Conference on Plasma Science. Held in San Francisco, CA on 16-21 June 2013. U.S. Government or Federal Purpose Rights License.			
14. ABSTRACT The Lethality Test System (LTS) is an experiment which will utilize a light gas gun-railgun combination to accelerate projectiles for impact studies, The power supply for the railgun consists of an 80 MJ (kinetic) generator-flywheel array used to charge the primary windings of three cryogenic pulse transformers. The secondary windings of these transformers will supply up to 50 MJ of electrical energy to the railgun. A number of special switching devices will be required to cause energy transfer and compression. This paper describes the design and testing of these switching devices.			
15. SUBJECT TERMS			
16. SECURITY CLASSIFICATION OF:			17. LIMITATION OF ABSTRACT
a. REPORT unclassified	b. ABSTRACT unclassified	c. THIS PAGE unclassified	SAR
			18. NUMBER OF PAGES 5
			19a. NAME OF RESPONSIBLE PERSON

The first module stores 60% of the total system energy and has a peak secondary discharge current of 925 kA. The remaining two modules are identical to one another. Each of these modules stores 20% of the system energy and has a peak secondary discharge current of 300 kA. A schematic of the first module is shown in Fig. 2. A schematic for the other two modules is shown in Fig. 3.

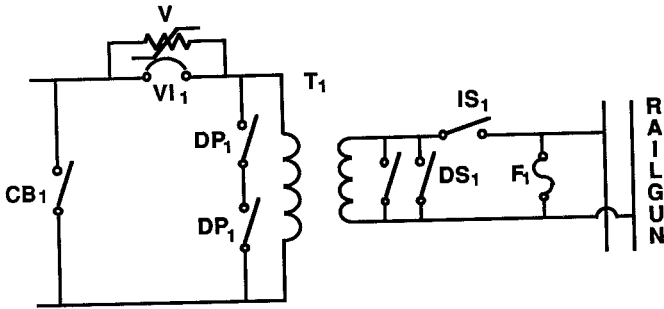

Fig. 2. Schematic for ESSM 1.

This device has a "make before break" feature and connects the secondary circuit to the railgun before interrupting current in the fuse link. The interruption process takes approximately 40 μ s as current is transferred to the plasma armature behind the projectile. Just before the projectile exits the railgun, an explosively-actuated, muzzle-crowbar switch, CB_m , is triggered. This switch diverts current from the plasma armature and relieves the acceleration stress from the projectile. After the projectile exits the railgun, primary dump switches, $DP_1 - DP_3$, and secondary dump switches, $DS_1 - DS_3$, close. These switches prevent the remaining transformer current from heating the rails excessively. They also provide a controlled energy dump in case an abort is necessary.

Switches TM and CB

The traction motor switch and transformer crowbar switches are all identical devices. This type of switch has been used extensively at LANL in applications where timing is not of critical importance.³ An oil-cooled version is presently being used at 25 kA dc in the Large Coil Project at ORNL.⁴ This author has successfully tested a water-cooled version at 80 kA dc. In LTS these switches must carry a current of 50 kA with an action of 3.3×10^9 A²s. The open-circuit holdoff requirement is 1.4 kV and the jitter on closing must be less than 5 ms.

The device consists primarily of a modified ITE Imperial (now Gould-Brown Boveri) rocker switch shown in Fig. 4. It has been modified by adding insulating contact guides, a pneumatic actuator, an oil-tight enclosure, and a control system. The mechanism shown is immersed in a silicone oil bath which has been previously tested to 60 kV. Although this level of insulation is not needed for its duty in LTS, prestrike at 1.4 kV is virtually eliminated. Contact engagement occurs 85 ms after command with a jitter of 2 ms. A photograph of an assembled device is shown in Fig. 5.

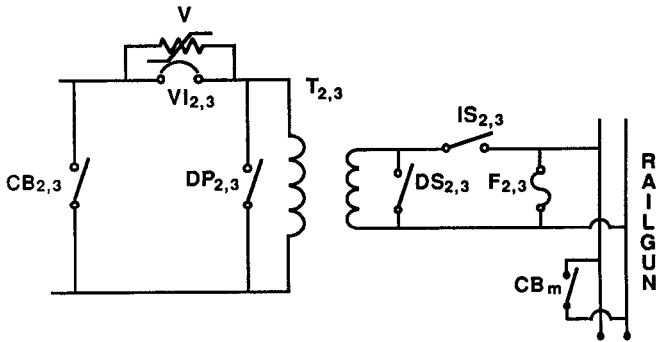

Fig. 3. Schematic for ESSM 2 and 3.

All the ESSMs behave in a similar fashion. After the crowbar switches close, secondary isolation switches, $IS_1 - IS_3$, close. Vacuum interrupters, $VI_1 - VI_3$, then open and interrupt the primary current in each transformer. Complete interruption of the primary currents requires 1.5 ms to 2.5 ms as the varistors, V, absorb the stray switching energy and uncoupled transformer flux. When the primary currents have reached zero, the secondary currents are maximum and flowing through switches, IS, and the explosive fuses, F. As the projectile nears a particular ESSM connection point, the explosive in fuse, F, is detonated.

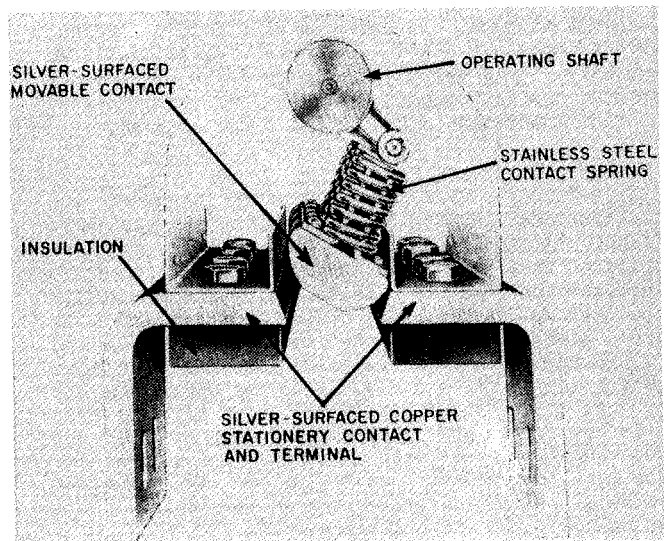

Fig. 4. Rocker switch mechanism.

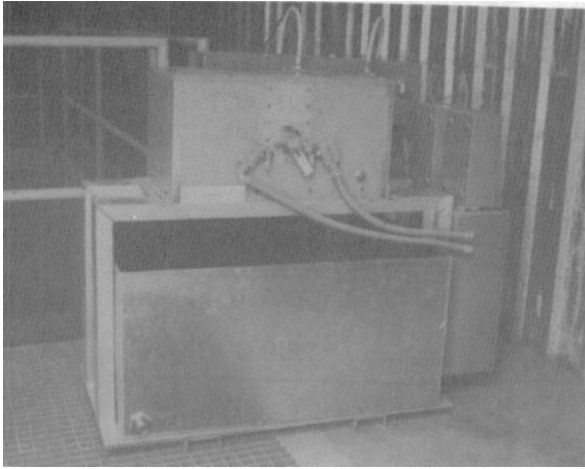

Fig. 5. Fully assembled rocker switch.

Vacuum Interrupters

Interruption of the current in the primary winding of the pulse transformer is necessary to establish full current in the secondary. Current interruption will be accomplished with a two stage circuit. The first stage consists of a commutated vacuum interrupter array that forces the primary current into a parallel second stage. The second stage is passive and consists of an assembly of zinc oxide varistors. A simplified schematic of this circuit is shown in Fig. 6. The varistors ultimately force the current in the primary winding to zero in a voltage-controlled fashion. They also absorb the energy associated with stray leakage flux in the transformer and railgun.

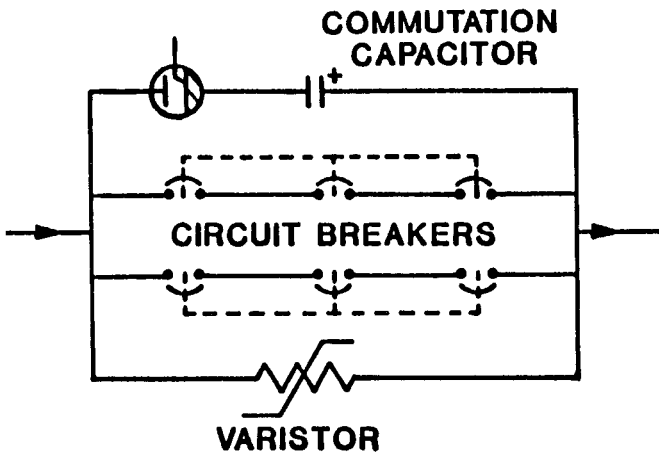

Fig. 6. Vacuum interrupter circuit.

Each vacuum interrupter array consists of two parallel-connected, three-phase circuit breakers. One of these three-phase breakers is shown in Fig. 7. The individual phases of each circuit breaker are connected in series. When the array is commutated by the 108 kJ capacitor bank, the 50 kA primary current is forced into the varistor. The varistor is designed to limit the voltage to 50 kV

at this current. Each vacuum interrupter, therefore, has to withstand 16.6 kV after interrupting 25 kA. This is well within the ability of such devices as shown by earlier tests done for fusion experiments.^{5,6}

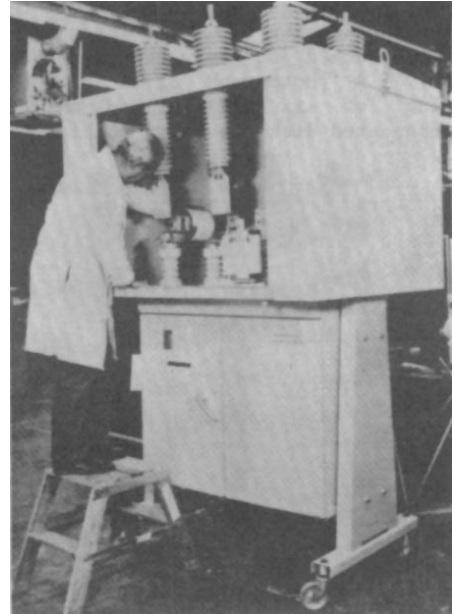

Figure 7. Three-phase vacuum circuit breaker.

A prototype interrupter array has been tested several hundred operations at currents up to 50 kA and voltages up to 52 kV. The measured current sharing at interruption between the two parallel branches was 53% and 47% respectively. Contact parting occurs approximately 30 ms after command. Full contact separation is achieved 8 ms later. Each of the three interrupter tubes in a single actuator was mechanically adjusted to open within a 1 ms window. The two actuators were then electrically timed for coincidental opening. Figure 8 shows typical current and voltage waveforms taken during a 50 kA interruption in a switch test facility. The waveform shape is a result of the staggered discharge of two capacitor banks in an attempt to simulate near dc conditions.

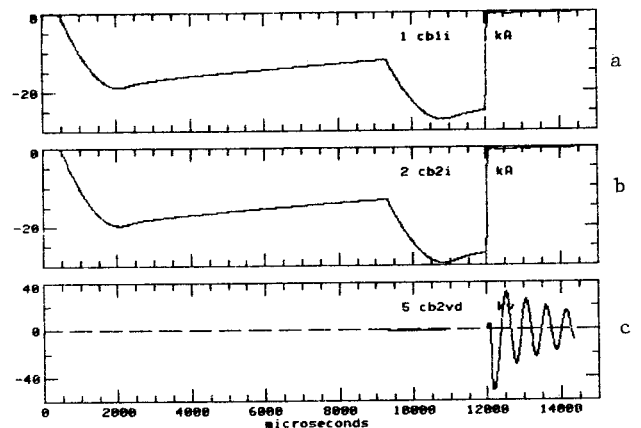

Fig. 8. Typical interruption waveforms
a. Current waveform, interrupter #1
b. Current waveform, interrupter #2
c. Voltage waveform.

The varistor assembly consists of 50 parallel columns of 9 series-connected disks. These disks each measure 75 mm o.d. by 23 mm thick and are capable of absorbing over 20 kJ each. The excellent nonlinear properties of these devices force the primary current to zero much faster than an ordinary resistor would. They can also be easily rearranged to vary the characteristics of the array. A photograph of a prototype array consisting of six parallel columns of seven, series-connected disks is shown in Fig. 9.

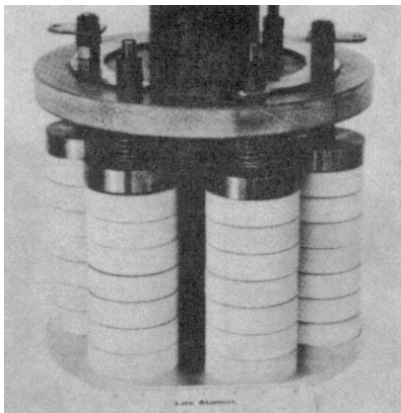

Fig. 9. Prototype varistor array.

Primary Dump Switches

The dump switches on the primary side of the transformers must be able to conduct 50 kA with an L/R decay time of 17 s. They must also withstand 100 kV in the open state and have a total closing time less than 15 ms. Such devices are not commercially available and so a design was undertaken.

Figure 10 shows a prototype switch. Each stationary terminal contains a circular arrangement of 24 silver-graphite, spring-loaded contacts. The moveable contact is a chromium-copper cylinder which is driven between the two sets of circular contacts by a pneumatic actuator. The actuator is pressurized to 500 psi, but motion is prevented by a latch and pawl mechanism. A command signal actuates an electrical solenoid which trips the latch and allows the linkage rod and moveable contact to accelerate. The contact chamber is pressurized with 50 psi SF₆ for high-voltage operation. Figure 11 shows contact travel, contact make, and solenoid trip current for a typical operation. Incipient motion occurs 3.3 ms after the trip signal is given. Contact engagement occurs at 11.15 ms.

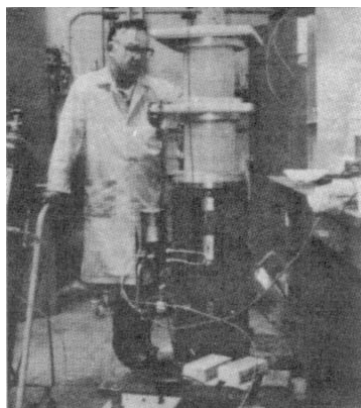

Fig. 10. Prototype primary dump switch.

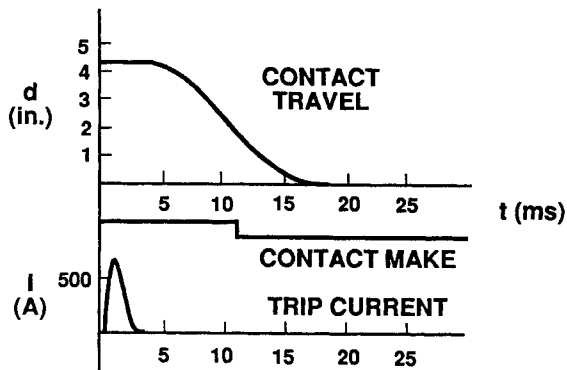

Fig. 11. Contact travel, make, and solenoid trip current.

Secondary Dump and Isolation Switches

The dump switches on the secondary side of T_1 must be able to conduct 925 kA with an L/R decay of 0.5 s. Due to the high action involved, two parallel switches will be used. On T_2 and T_3 the current level is 300 kA, and the decay time is 0.3 s. A single dump switch is sufficient for these ESSMs. The same type of device is also used for the secondary isolation switches. All three ESSMs use a single switch in this position due to the rather short conduction time involved.

The actual device used for secondary dump and isolation is a slightly modified version of a switch⁷ used in the Doublet-III fusion experiment at GA Technologies. The switch is very similar to the primary dump switches in that it consists of two circular arrangements of stationary contacts and a pneumatically actuated moveable contact. There are 36 individual elements in each of the stationary contacts on these switches while the primary dump switches have only 24. These switches also have a shorter contact stroke and are not pressurized with SF₆. They are rated for 20 kV holdoff in the open state and begin contact engagement 9.7 ms after command.

Explosive Fuses

The high velocities anticipated in the LTS require very precise and rapid delivery of current to the plasma armature. The anticipated projectile velocities at the three ESSM connection points are 5 km/s, 7 km/s, and 10 km/s. This requires the final stage of switching to have a current transfer time no more than 50 μ s with less than 10 μ s of jitter. Explosively-actuated fuses are ideally suited to these requirements.⁸

A novel feature of the fuses is a "make before break" capability. In order to prevent unwanted interaction between the three, current-carrying fuses connected to the railgun, two of them will incorporate a special explosive element. This element connects one side of the fuse to the railgun just prior to the explosive action of the fuse element. A diagram of this device is shown in Fig. 12.

crowbar switch will divert approximately 70% of the armature current but requires precise timing due to the anticipated projectile velocity. The explosive make switch is ideally suited for this task since contact closure begins only 10 μ s after command.

Conclusion

The LTS railgun power supply is being constructed primarily with off-the-shelf or previously developed components. The switching devices in this system are no exception. The traction motor and transformer crowbar switches are based on commercial switches used extensively in the aluminum refining industry. The vacuum interrupters use enclosed actuators common to the utility business. The secondary dump and isolation switch design has been used in the Doublet III fusion experiment for over ten years. The switches that did require special design were modeled after similar existing devices. These include the primary dump switches and the explosive fuses. A novel combination of explosive "make" and "break" switches in one device is an exception and appears to be a first time development.

References

- [1] Parsons, W.M., Sims, J.R., Parker, J.V., "The Lethality Test System," presented at the 3rd Symp. on Electromagnetic Launch Tech., Austin, TX, April 20-24, 1986.
- [2] Parsons, W.M., Parker, J.V., Thullen, P., "Railgun Power Supply Utilizing Traction Motors and Vacuum Interrupters," presented at the 5th IEEE Pulsed Power Conference, Arlington, VA, June 10-12, 1985.
- [3] Honig, E.M., Warren, R.W., "The Use of Vacuum Interrupters and Bypass Switches to Carry Currents for Long Times," Proc. 13th Pulse Power Mod. Symp., Buffalo, NY, June 20-22, 1978.
- [4] Parsons, W.M., "LCT Protective Dump Switch Tests," Proc. 9th Symp. on Eng. Prbs. of Fus. Res., Chicago, IL, Oct. 26-29, 1981.
- [5] Tamura, S., Shimada, R., Kito, Y., Kanai, Y., Koika, H., Ikeda, H., Yanabu, S., "Parallel Interruption of Heavy Direct Current by Vacuum Circuit Breakers," IEEE Trans. PAS, Vol. PAS-99 No. 3, May, June 1980.
- [6] Parsons, W.M., Warren, R. W., Honig, E.M., Lindsay, J.D.G., Bellamo, P., Cassel, R.L., "Interrupter and Hybrid Switch Testing for Fusion Devices," Proc. 8th Symp. on Eng. Prob. of Fusion Res., San Francisco, CA, Nov. 13-16, 1979.
- [7] Woods, E.L., Wildi, P., "High Current Switches in the Doublet III Poloidal Field Circuit," Proc. IEEE 7th Symp. on Eng. Prob. of Fus. Res., 1977, pp. 1753-1756.
- [8] Conte, D., Ford, R.D., Lupton, W.H., Vitkovitsky, I.M., "Two Stage Opening Switch Techniques for Generation of High Inductive Voltage", Proceedings of Seventh Symposium of Engineering Problems of Fusion Research, IEEE Cat. No. 77CH1267-4-NPS (1977). p. 1066.

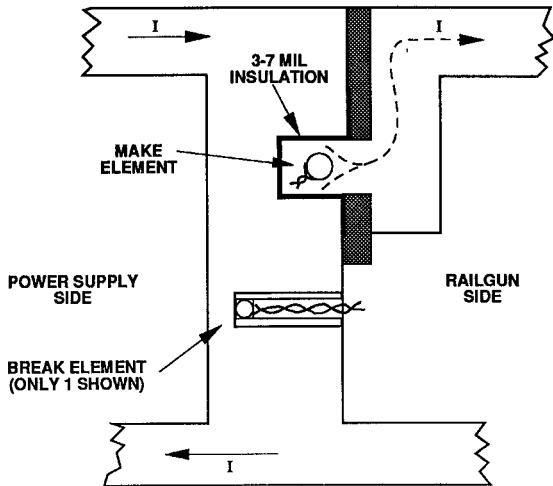

Fig. 12. Explosive "make before break" fuse.

Operation of the switch assembly is as follows: both the "make" contact and the "break" contacts use an exploding bridge wire (EBW) detonator attached to an appropriate length of 50 grain per foot PETN detonating cord. Upon arrival of a firing pulse, there is a 3 microsecond delay before explosive breakout from the detonator initiates detonation of the cord. Once initiated, the detonation proceeds at approximately 0.7 centimeters per microsecond until completed.

Typically, for a 3-layer (7 mils per layer) insulator on the make contact, first closure occurs at 10 microseconds after firing pulse arrival. For the opening contacts, the first arc voltage appears at twenty microseconds using a 0.1 inch thick conductor. Thus the make switch is closed prior to break contact opening in normal operation.

The "make" contact is held tightly closed by explosive pressure for several hundred microseconds. The risetime of the opening switch arc voltage is only 40 μ s so that one would expect very low contact resistance during current commutation to the gun rails. Late time contact resistance has been measured using a four terminal bridge and found to be $4\mu\Omega$ for a 3 inch long contact.

The arc voltage for the break contact rises in 40 microseconds to approximately 2 kV per gap. Voltage holdoff after 500 microseconds exceeds 5 kV per gap.

The firing set used to initiate explosive operation uses 9-volt batteries for prime power and is activated and fired from the control area via fiber-optic cables. The firing set delivers eight transformer coupled output pulses of 1 kA at 1 kV and has a current rise time of less than 1 microsecond.

A "make only" version of this device will be used as a muzzle crowbar switch. Such a switch is required due to the substantial amount of current in the plasma armature as the projectile nears the railgun muzzle. This current would cause the projectile to disintegrate from acceleration stresses during exit from the railgun. The muzzle