

**DESIGN OF A BATTERY POWER SUPPLY FOR
THE ELECTROMAGNETIC GUN EXPERIMENTAL RESEARCH FACILITY**

J. D. Sterrett
Air Force Armament Laboratory, AFATL/SAH,
Eglin Air Force Base, Florida

J. R. Lippert
Computer Science and Applications Inc.,
Fort Walton Beach, Florida

M. R. Palmer, N. E. Johnson and M. C. Altstatt
Science Applications International Corporation,
Shalimar, Florida

ABSTRACT

A high power and high energy battery power supply is currently being designed to support electromagnetic (EM) launcher research at the Air Force Armament Laboratory, Eglin Air Force Base, Florida. The design goals for this system are to supply megawatts of pulsed power at high current levels for a five second period. This paper discusses the rationale which led to this system selection. The specific system design is also discussed along with the issues of safety, charging, diagnostics, control system configuration, power conditioning and the ever present problem of high-current switching.

INTRODUCTION

A large battery power supply is being designed to support rapid-fire electromagnetic (EM) launcher research at the Air Force Armament Laboratory, Eglin Air Force Base, Florida. The system will be constructed at the EM Gun Experimental Research Facility (EMGERF) at Eglin in 1987. This battery facility and an accompanying experimental bay are shown in Figure 1. The design goals for this system are to construct a system to supply megawatts of pulsed power at high current levels for a five second period. Future upgrades are planned to provide even higher levels of power at higher current levels.

The design objectives are to provide a laboratory power supply which maximizes the total power and energy while at the same time minimizing the developmental risk and cost. System size and weight are unlimited, but maximum reliability and ease of operation are key goals. The intent is to utilize the resulting power supply for routine laboratory testing of EM launcher components on a daily basis over several years.

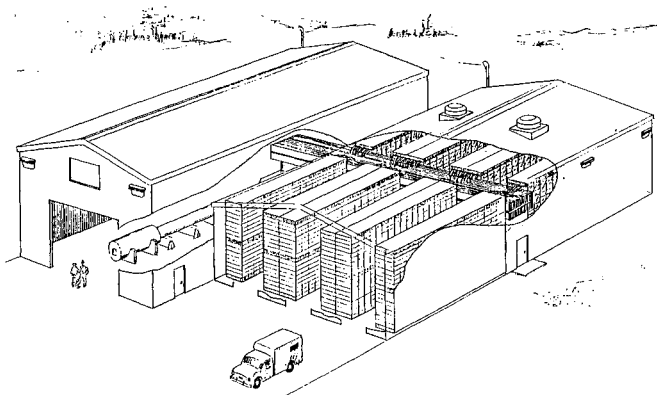

Figure 1. Battery Power Supply Facility.

Adjustable current flows from several thousand amperes to full system capability will be available with durations from one second to five seconds. Pulse repetition rates will depend on the discharge level but two, full current five second discharges, or their coulomb equivalent, will be possible before the system needs to be recharged. The recharging process will take between twenty-four and forty-eight hours.

Cost, reliability and schedule constraints dictate that only stock automotive batteries be considered to power this high energy system. Homopolar generators would entail much higher cost, longer lead time and lower reliability. Capacitors would be much higher in cost and occupy a much larger volume thus requiring much higher buss costs. Although these problems will be ameliorated with further development, construction in 1987 allows only present technology to be considered.

SYSTEM OVERVIEW

The overall system schematic is shown in Figure 2 and represents the series parallel arrangement of 16,128 batteries. These batteries are arranged in a basic series string of 16 batteries which can be reconfigured into two parallel strings of 8 batteries each. Hence the power supply is made up of 1,008 parallel strings of 16 batteries or 2,016 strings of 8 batteries in series. Twenty four parallel strings are grouped together into a gang for the purpose of switching and control and there are 42 of these parallel gangs. Associated with each gang is a crowbar switch and resistor which will be used to dissipate the inductively stored energy prior to the opening of the gang switches.

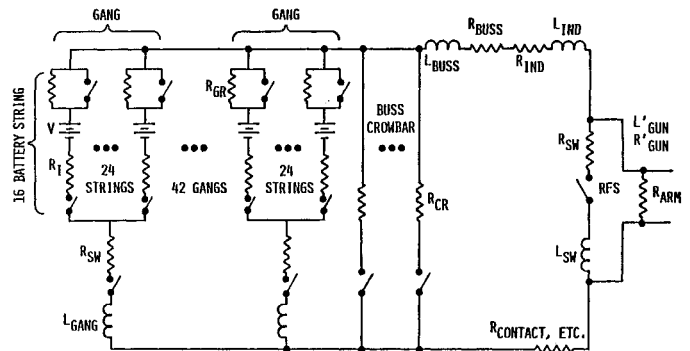

Figure 2. Battery Power Supply Schematic.

Report Documentation Page

Form Approved
OMB No. 0704-0188

Public reporting burden for the collection of information is estimated to average 1 hour per response, including the time for reviewing instructions, searching existing data sources, gathering and maintaining the data needed, and completing and reviewing the collection of information. Send comments regarding this burden estimate or any other aspect of this collection of information, including suggestions for reducing this burden, to Washington Headquarters Services, Directorate for Information Operations and Reports, 1215 Jefferson Davis Highway, Suite 1204, Arlington VA 22202-4302. Respondents should be aware that notwithstanding any other provision of law, no person shall be subject to a penalty for failing to comply with a collection of information if it does not display a currently valid OMB control number.

1. REPORT DATE JUN 1987	2. REPORT TYPE N/A	3. DATES COVERED -	
4. TITLE AND SUBTITLE Design Of A Battery Power Supply For The Electromagnetic Gun Experimental Research Facility		5a. CONTRACT NUMBER	
		5b. GRANT NUMBER	
		5c. PROGRAM ELEMENT NUMBER	
6. AUTHOR(S)		5d. PROJECT NUMBER	
		5e. TASK NUMBER	
		5f. WORK UNIT NUMBER	
7. PERFORMING ORGANIZATION NAME(S) AND ADDRESS(ES) Air Force Armament Laboratory, AFATL/SAH, Eglin Air Force Base, Florida		8. PERFORMING ORGANIZATION REPORT NUMBER	
9. SPONSORING/MONITORING AGENCY NAME(S) AND ADDRESS(ES)		10. SPONSOR/MONITOR'S ACRONYM(S)	
		11. SPONSOR/MONITOR'S REPORT NUMBER(S)	
12. DISTRIBUTION/AVAILABILITY STATEMENT Approved for public release, distribution unlimited			
13. SUPPLEMENTARY NOTES See also ADM002371. 2013 IEEE Pulsed Power Conference, Digest of Technical Papers 1976-2013, and Abstracts of the 2013 IEEE International Conference on Plasma Science. Held in San Francisco, CA on 16-21 June 2013. U.S. Government or Federal Purpose Rights License.			
14. ABSTRACT A high power and high energy battery power supply is currently being designed to support electromagnetic (EM) launcher research at the Air Force Armament Laboratory, Eglin Air Force Base, Florida. The design goals for this system are to supply megawatts of pulsed power at high current levels for a five second period. This paper discusses the rationale which led to this system selection. The specific system design is also discussed along with the issues of safety, charging, diagnostics, control system configuration, power conditioning and the ever present problem of highcurrent switching.			
15. SUBJECT TERMS			
16. SECURITY CLASSIFICATION OF:			17. LIMITATION OF ABSTRACT
a. REPORT unclassified	b. ABSTRACT unclassified	c. THIS PAGE unclassified	SAR
			18. NUMBER OF PAGES 4
			19a. NAME OF RESPONSIBLE PERSON

The string schematic is shown in Figure 3. This figure shows the arrangement of the 16 batteries and the three DC contactors which will be used to open and close the circuit at the string level. Also shown in this figure is the grading resistor. The purpose of this resistor is discussed below. Mechanically, Figure 3 shows two groupings of eight batteries each, which represents the mechanical arrangement of eight batteries in a tray. Batteries are contained in fiberglass trays to facilitate maintenance. Such maintenance will be performed outside of the battery bay due to safety considerations. A stock picker, fitted with a tray extraction device, will be used to move battery trays in and out of the battery facility.

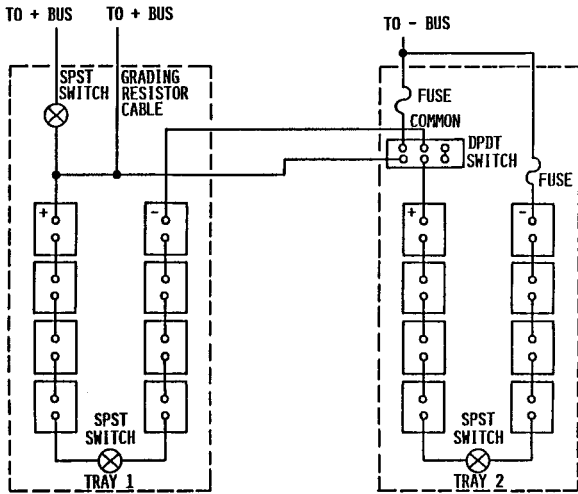

Figure 3. Battery String Layout.

Figure 4 is a plan view of the building which will house the battery system. The solid lines show the plan view of the battery racks which will be used for the initial system while the dotted lines along the wall show the racks which will be used for a future upgrade. The buss is shown in the center of the figure. Each of the racks is 16 battery trays high and 18 trays long as shown in Figure 5. Two cabling paths are provided above the eighth and sixteenth trays. These paths will feed current to the top and bottom of the copper buss respectively. The current will flow from the battery trays to the buss in 4/0 cable. The gang switches will be located at the top and bottom of the copper buss. The buss is made up of two levels of 5/8 by 18 inch copper plates with 28 plates per level.

SAFETY AND RELIABILITY

The battery power supply will contain on the order of one hundred thousand components. Attaining high safety and reliability was one of the greatest challenges in the system design effort.

Hydrogen explosions, electrocution of personnel, and switch/battery fires were found to be the most important hazards. Risk of severe system damage or personnel injury will be reduced to extremely low levels by a combination of features. These include operating procedures, monitoring systems, passive safeguards, redundancy, and automatic damage control systems.

Hydrogen safeguards include peak roof vents and fans which yield one air exchange per minute during charging. Multiple monitors ensure warning of

dangerous concentrations. Discharges will be delayed 10 hours after charging to allow diffusion of intrabattery hydrogen, which could be ignited by internal battery arcing.

Electrocution risks will be minimized by the multiple series open switches in each string. Fail safe red-green indicator lights on each gang will annunciate failure of these switches to open. Maintenance personnel will therefore not be exposed to voltages greater than 60 volts, a safe working voltage.

Switch fires are expected to occasionally occur. Their impact will be minimized by system switch redundancy and by water spray systems which will isolate a fire to a small area in each rack.

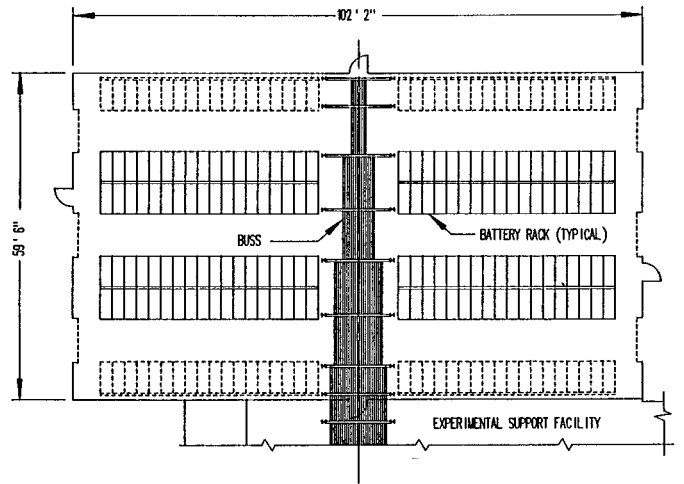

Figure 4. Battery Power Supply Facility Floor Plan.

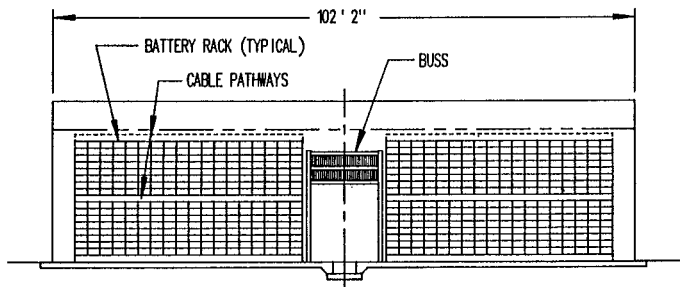

Figure 5. Battery Power Supply Facility Elevation View.

ELECTRICAL SPECIFICATIONS

The circuit values for the string level schematic are shown in Table 1 and the circuit values for the load are shown in Table 2. It is important to note that for a general laboratory power supply the exact value of the load resistance is not known a priori. The load resistance is thus taken to range from 25 to 50 microohms. This variance led to the eight and sixteen battery string choice with the eight battery strings being used for the lower load resistances.

Table 1. Power Source Circuit Values.

16 BATTERY STRING	8 BATTERY STRING
$V = 16 \times 12.6 = 201.6v$	$V = 8 \times 12.6 = 100.8v$
$R_{BATT} = 16 \times 3.9m\Omega$	$R_{BATT} = 8 \times 3.9m\Omega$
$R_{SW} = 3 \times 100\mu\Omega$	$R_{SW} = 2 \times 100\mu\Omega$
$R_{SW} = 1 \times 150\mu\Omega$	$R_{SW} = 1 \times 150\mu\Omega$
$R_{CABLE} = 30 \text{ Ft.} \times 2 \times 50\mu\Omega$	$R_{CABLE} = 30 \text{ Ft.} \times 2 \times 100\mu\Omega$
$R_l = 65.85m\Omega$	$R_l = 37.55m\Omega$
$R_{GR} = 50m\Omega$	
<u>GANG</u>	
$R_{SW} = 100\mu\Omega$	
$L_{GANG} = 0.594\mu H$	

Table 2. Load Circuit Values.

RESISTANCE	INDUCTANCE
$R_{IND} = 5\mu\Omega \rightarrow 20\mu\Omega$	$L_{IND} = 5\mu H \rightarrow 50\mu H$
$R_{BUSS} = 5\mu\Omega$	$L_{BUSS} = 0.5\mu H$
$R_{SW} = 10\mu\Omega$	$L_{SW} = 0.01\mu H$
$R_{CONTACT, ETC} = ?$	
$R_{LOAD} = 25\mu\Omega \rightarrow 50\mu\Omega$	$L_{LOAD} = 5.51\mu H \rightarrow 50\mu H$

The battery which has been selected is a heavy duty automotive battery with a rating of 850 cold cranking amperes and lead-calcium chemistry to minimize gassing during the charging cycle. This choice is the result of in-house battery testing [1]. These batteries are capable of delivering currents in excess of 2,000 amperes for a period of 5 seconds and have a maximum power output of approximately 11 KW per battery.

The grading resistor, which is shown in Figure 2, is made up of approximately 80 feet of 5/8 inch braided steel cable. This cable has a resistance value of approximately 600 microohms per foot of length and thermal characteristics which raise the temperature approximately 70 C during a five second, two thousand ampere discharge. This cable will be routed in parallel with the 4/0 copper cable between the strings and the copper buss.

The switches shown in Figure 3 are heavy-duty DC contactors with magnetic arc blowouts. These switches will be used to configure the strings into eight or sixteen batteries and are also used to break down the string voltages when the system is not in use. The gang switches are shown in Figure 2. These are pneumatic V-block switches with a contact width of six inches and a contact thickness of 3/4 inch. These switches will handle the current of 24 strings and accept the 24 cables on one side and bolt directly to the copper buss on the other. The crowbar switches shown in Figure 2 are also of a similar design and will short across the copper buss. The principal difference

between these two pneumatic switches is that the gang switches will be fail-safe open and the crowbar switches will be fail-safe closed.

The inductance of the battery system has been minimized to keep the switch arcing problem to a minimum. The cable runs between the battery trays and the buss will be interwoven and the buss connections will be made close together in order to minimize the cabling inductance. Also the current directions will be alternated between adjacent trays to reduce field coupling.

SYSTEM PERFORMANCE

Figure 6 shows the system current and the string currents versus the number of battery strings in use for three different load resistances of 25, 35 and 50 microhms. With 1,000 battery strings and a 35 microohm load the system current is approximately two million amperes. Figure 7 is a similar plot for eight battery strings and a comparison of these two figures shows the effect of the load resistance on the system output. It is interesting to note that as the system current is decreased the current draw per string increases. This result is due to the battery system

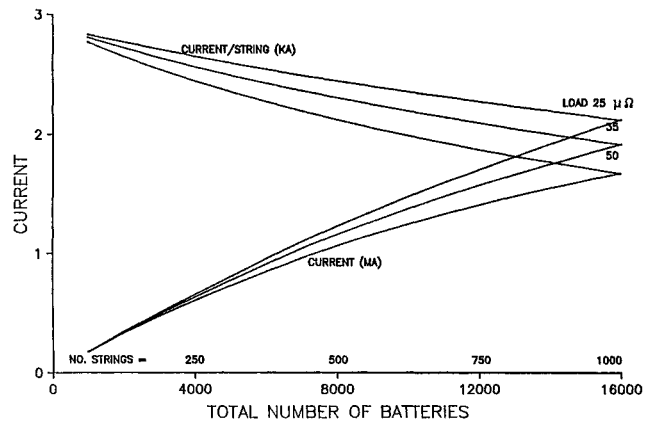

Figure 6. System Output and String Current versus Number of Batteries for 16 Battery Strings.

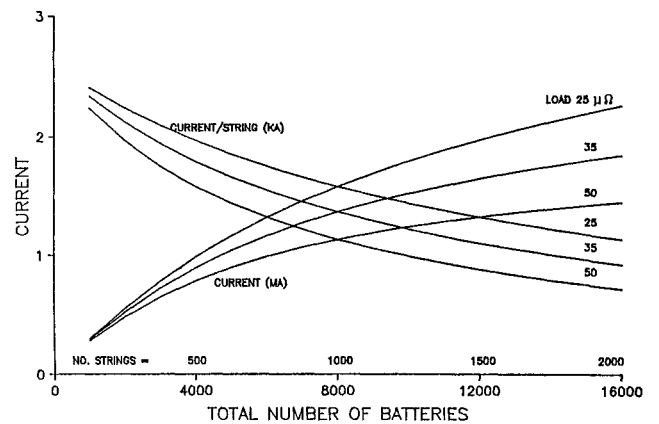

Figure 7. System Output and String Current versus Number of Batteries for 8 Battery Strings.

resistance increase as fewer parallel strings are used. Figures 8 and 9 show the same conditions as Figures 6 and 7 but with the grading resistance switched into each string. The grading resistance has the effect of lowering the string currents to acceptable levels during low current discharges.

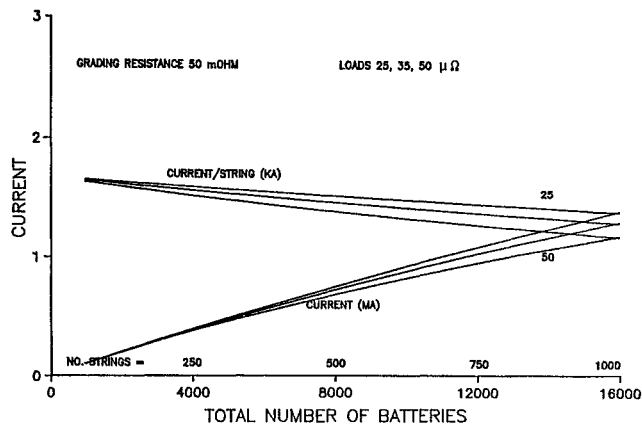

Figure 8. System Output and String Current versus Number of Batteries with Grading Resistance for 16 Battery Strings.

CONTROL, CHARGING AND DIAGNOSTIC SYSTEMS

Each of the string switches and each of the gang switches will be controlled from a central controller. In this manner any string or gang can be switched in or out of the system. This type of control will be used to facilitate the charging system which is designed to charge at the single battery string level. Eight separate chargers will operate simultaneously with each charging an individual battery string. Each string will receive approximately 110% of the discharged coulombs and then the charger will move on to the next battery string. During the charging process the string current and voltage will be monitored and after charging a load test will be performed on each string. Any string not passing these diagnostics will be flagged by the controller for maintenance and cannot be switched into the system during a discharge. The charging operation will require 24 hours following a five second full current discharge.

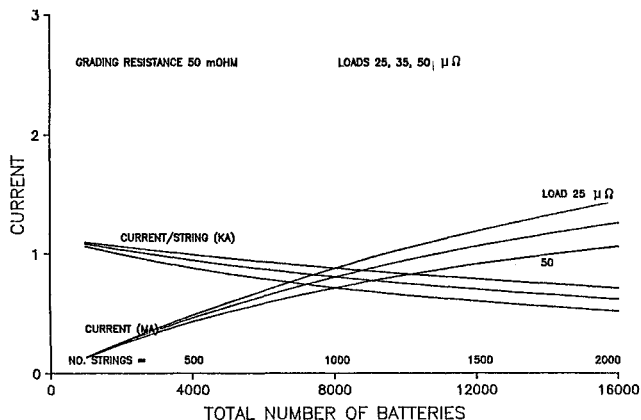

Figure 9. System Output and String Current versus Number of Batteries with Grading Resistance for 8 Battery Strings.

SYSTEM OPERATION

A typical system discharge will begin with the batteries in a full state of charge and the controller programmed for the number of strings to include and the time duration of the discharge. As the pneumatic system is charged the crow-bar switches will open and the rapid fire switch will be closed. The string level switches are now closed and then the gang switches close and current begins to flow. When the inductor is charged the launcher firing sequence begins and after the appropriate number of shots ends with the rapid fire switch in the closed position. Now the problem is to open the battery circuit. At this time the crow-bar switches are closed and then the gang switches are opened. At this point the current flow should be stopped and the string level switches will be opened. In the case of a gang switch failure the string level switches will be used to open the circuit.

REFERENCES

1. M. R. Palmer, E. C. Kirkland, J. B. Cornette, and L. E. Thurmond, "Component and Subscale Testing in Support of the Design of a Battery Power Supply for the Electromagnetic Gun Research Facility," presented at the 6th IEEE Pulsed Power Conference, Washington, D.C., June 29-July 1, 1987.