

ESTCP Project WP-0801, UV Curable Powder Coatings for Military Applications



Presenter: Mr. Christopher W. Geib,
Science Applications International Corporation
(SAIC)

937.431.4332

geibc@saic.com

Report Documentation Page

Form Approved
OMB No. 0704-0188

Public reporting burden for the collection of information is estimated to average 1 hour per response, including the time for reviewing instructions, searching existing data sources, gathering and maintaining the data needed, and completing and reviewing the collection of information. Send comments regarding this burden estimate or any other aspect of this collection of information, including suggestions for reducing this burden, to Washington Headquarters Services, Directorate for Information Operations and Reports, 1215 Jefferson Davis Highway, Suite 1204, Arlington VA 22202-4302. Respondents should be aware that notwithstanding any other provision of law, no person shall be subject to a penalty for failing to comply with a collection of information if it does not display a currently valid OMB control number.

1. REPORT DATE MAY 2009	2. REPORT TYPE	3. DATES COVERED 00-00-2009 to 00-00-2009	
4. TITLE AND SUBTITLE ESTCP Project WP-0801, UV Curable Powder Coatings for Military Applications		5a. CONTRACT NUMBER	
		5b. GRANT NUMBER	
		5c. PROGRAM ELEMENT NUMBER	
6. AUTHOR(S)		5d. PROJECT NUMBER	
		5e. TASK NUMBER	
		5f. WORK UNIT NUMBER	
7. PERFORMING ORGANIZATION NAME(S) AND ADDRESS(ES) Science Applications International Corp,4031 Colonel Glenn Highway,Beavercreek,OH,45431		8. PERFORMING ORGANIZATION REPORT NUMBER	
9. SPONSORING/MONITORING AGENCY NAME(S) AND ADDRESS(ES)		10. SPONSOR/MONITOR'S ACRONYM(S)	
		11. SPONSOR/MONITOR'S REPORT NUMBER(S)	
12. DISTRIBUTION/AVAILABILITY STATEMENT Approved for public release; distribution unlimited			
13. SUPPLEMENTARY NOTES Presented at the NDIA Environment, Energy Security & Sustainability (E2S2) Symposium & Exhibition held 4-7 May 2009 in Denver, CO.			
14. ABSTRACT			
15. SUBJECT TERMS			
16. SECURITY CLASSIFICATION OF:			17. LIMITATION OF ABSTRACT
a. REPORT unclassified	b. ABSTRACT unclassified	c. THIS PAGE unclassified	Same as Report (SAR)
			18. NUMBER OF PAGES 19
			19a. NAME OF RESPONSIBLE PERSON

Outline

- UV-Curable Powder Coatings Overview
- Robotics as an aid to Curing
- Current Status of ESTCP Project WP-0801
- Future UVCPC efforts



UV-Curable Powder Overview

- Previous ways of thinking about powder
 - Coating cure temperatures – typically above 428°F
 - Prohibitive for use on tempered metals (Al, Mg, Ti)
 - Prohibitive to use on composites
 - Powder coatings were designed as barrier protection

UV-Curable Powder Overview

- Modern powder coatings can be formulated to have:
 - Lower melt & flow temperatures ($< 225^{\circ}\text{F}$)
 - UV or EB cure functionality can be added
 - Various advanced non-chrome corrosion inhibitors



UV-Curable Powder Overview

- Advantages of UV-cure powder coating:
 - Elimination of volatile organics (VOC)
 - Elimination of hazardous air pollutants (HAP)
 - Reduction/elimination of hazardous waste
 - Transfer efficiencies as high as 95% (w/reclaim)
 - Decrease in thermal exposure.
 - Large bulky parts that cannot fit into existing ovens can be coated and cured.
 - UV-cure powder requires less energy because the energy is focused to a specific part only as long as needed.

Robotics as an Aid to Curing

- Why Use Robots?

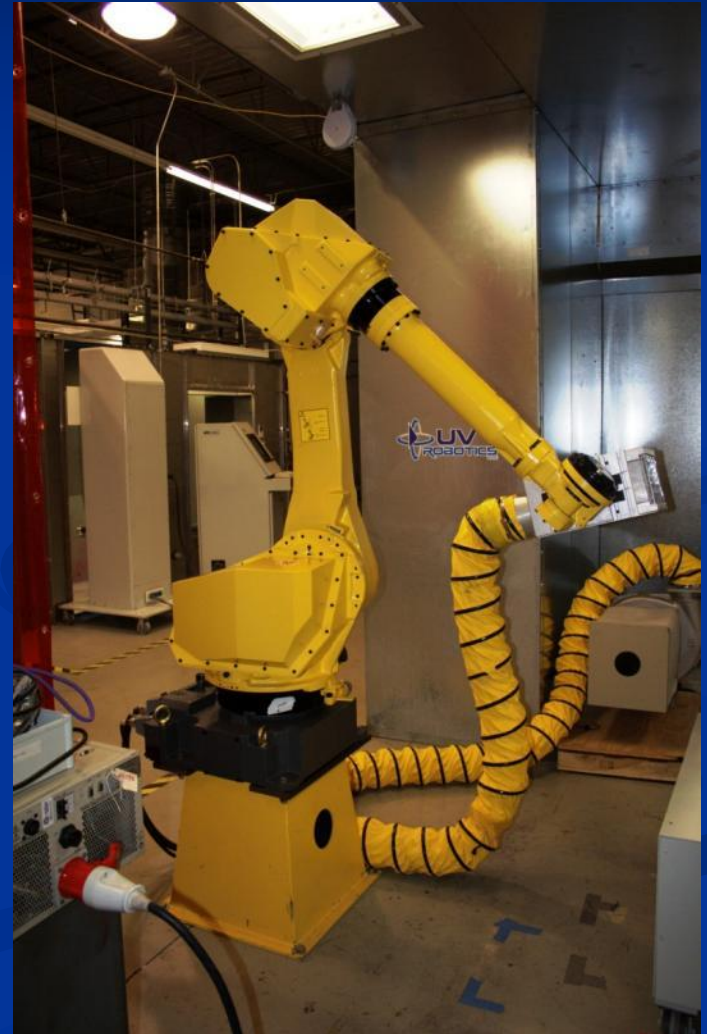
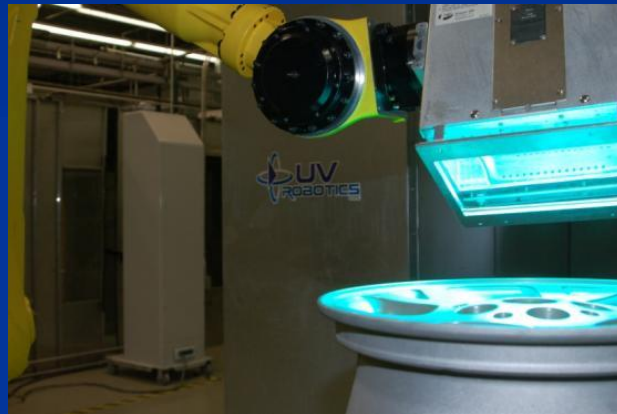

Robotics as an Aid to Curing

- Light tunnel approach using various size UV lamps to optimize cost and exposure

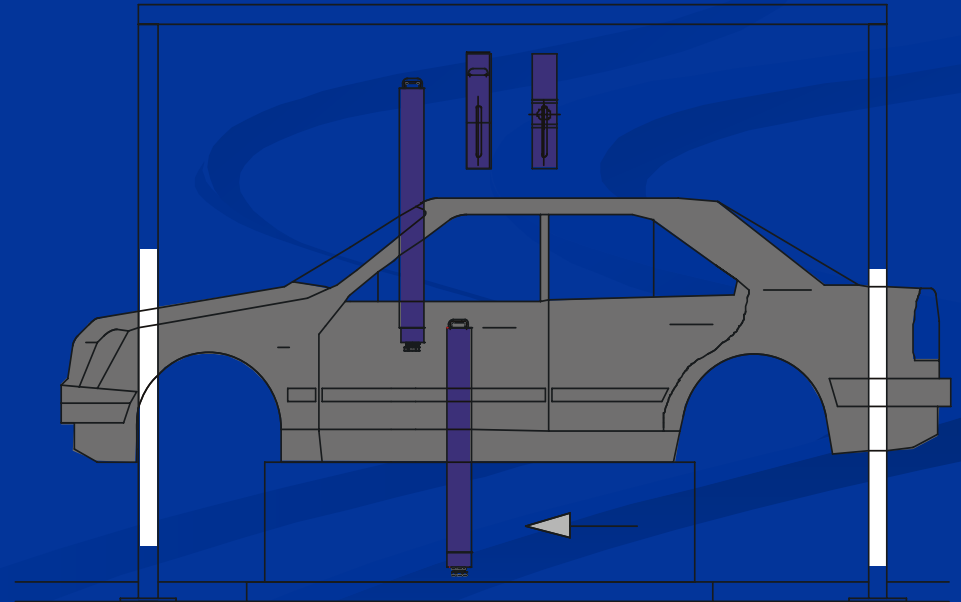
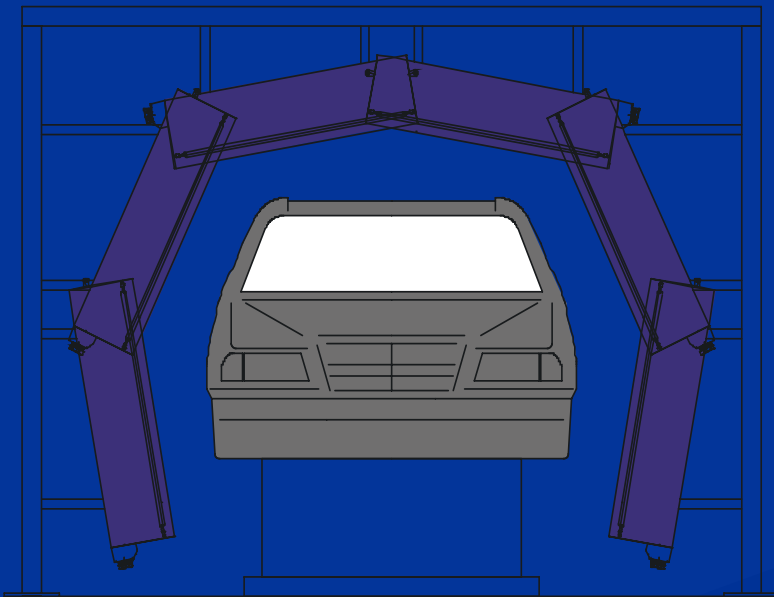

Robotics as an Aid to Curing

- Drawbacks of fixed lamp approach
 - High Capital Costs
 - Lamps, cooling, fixtures, integration
 - High Operating Costs
 - Replacement parts
 - Energy
 - Downtime
 - Technical Adequacy
 - Complete cure
 - Proper Re-alignment
 - Mixed product

Robotics as an Aid to Curing

- Advantages of Robotic Curing
 - Robots ensure repeatability
 - Robots with UV sources can maintain extremely close target distances
 - Robots can be re-programmed in seconds
 - Robotic curing is well suited to large or complex parts
 - Robots eliminate need for many lights

Current Status of ESTCP Project WP-0801

- The Problem:
 - DoD spends millions of dollars annually on solvent-based coatings
 - Hexavalent chrome primer use still very widespread
 - Contains or requires volatile solvent use
 - Significant hazardous waste costs
 - Hazardous materials pose risks to human health and environment
 - Process times measured in hours to days
 - Transfer rates are less than 60%

Current Status of ESTCP Project WP-0801

- The WP-0801 Objectives are:
 - Demonstrate a VOC/HAP-free, Ultraviolet cure powder coating (UVCPC) on DoD hardware
 - Demonstrate state-of-the-art robotics for curing



Current Status of ESTCP Project WP-0801



- Requirements of a UVCPC for military use:
 - Must perform at least as well as MIL-PRF-23377 primer
 - Must also perform as well as MIL-PRF-85285 topcoat
 - Can be prepared in gloss, semi-gloss, and flat finishes



Current Status of ESTCP Project WP-0801

■ Planned demonstration weapon systems:



EA-6B wheels, landing gear



HH-65 helicopter



P-3 wheels, landing gear, radomes



Mk-48 ADCAP torpedo



HC-130 main landing gear doors



KC-135 wing flap, refueling boom

Current Status of ESTCP Project WP-0801

■ Planned demonstration weapon systems (cont.):



Submarine icecaps



EA-18G wheels, landing gear



Ammunition and storage cases



Submarine communication buoys

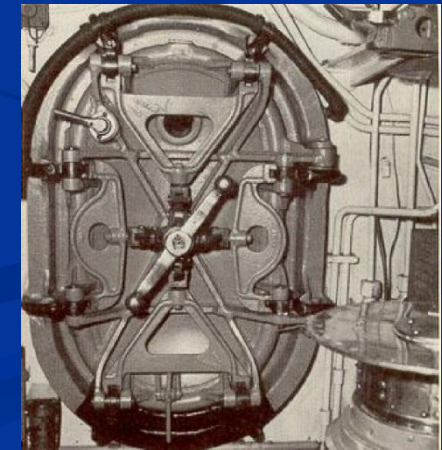

Submarine interior components

Current Status of ESTCP Project WP-0801

- Powders:
 - Currently considering two vendors
 - Two colors, gloss white, semi-gloss gray
 - All will undergo strict validation testing at CTIO
- Robotics system:
 - Robot carries the IR and Hg vapor UV lamps
 - Evaluation of alternative UV sources continue
 - Evaluation of alternative application methods continue

Current Status of ESTCP Project WP-0801

- Major Program Milestones:
 - Joint Test Protocol submitted Sept 2008
 - Robot acquired and integration underway
 - Component identification complete
 - Powder and substrates order Jan 2009
 - Validation testing starts Feb 2009
 - Draft Demonstration Plan June 2009
 - Field Service/Demonstration begins Mar 2010
 - Joint Test Report draft Sept 2010
 - Final Report Mar 2012

Future UVCPC Efforts

- Future follow on efforts include large marine applications



Future UVCPC Efforts

- Future efforts in alternative UV light sources



High Energy UV LEDs



Pulsed Xenon lamps

Thank You!

Points of contact for UV-curable Powder Coatings ESTCP Project WP-0801:

Mr. Corey Q. Bliss
Principal Investigator
Air Force Research Laboratory/RXSSO
Wright-Patterson AFB, OH 45433
Corey.Bliss@wpafb.af.mil
(937) 255-0943

Mr. Christopher W. Geib
Co-Principal Investigator
Science Applications International Corp.
4031 Colonel Glenn Highway
Beavercreek, OH 45431
Christopher.W.Geib@saic.com
(937) 431-4332