

A FACILITY FOR HIGH-REPETITION-RATE SWITCH TESTING AT MEDIUM POWER

Stuart L. Moran, R. Kenneth Hutcherson Jr., Edwin D. Ball
 Naval Surface Weapons Center, Dahlgren Laboratory
 Dahlgren, Va. 22448

Abstract

A one-ohm, 2.5 gigawatt, liquid-filled pulse forming line has been built which can be resonantly charged to 100kV in one millisecond, or pulsed charged at variable repetition rates. The facility average power is 200 kW but can exceed this in a burst mode. This paper describes the facilities to support switching experiments and some of the test results. One goal is to develop a high rep-rate spark gap without gas flow. Based on previous work, high pressure, light gases such as hydrogen will be needed as well as a "stiff" trigger to break down the gap well below D.C. The gas handling system can operate up to 70 atm. and includes flash arresters and emergency shutoffs. The triggering system uses a thyatron to discharge a capacitor through a transformer. Data is digitized locally and transferred optically for manipulation. The facility is set up to use optical diagnostics and interferometry.

Introduction

A facility is being constructed to demonstrate millisecond charging of a liquid-filled pulse forming line (PFL), to study large-area water-breakdown, and to serve as a test bed for medium-power high rep-rate switching. The facility is designed not only for demonstration but also to perform research experiments in these areas. The facility includes a 2.5 gigawatt, liquid-filled pulse forming line which can be resonantly charged in one millisecond to 100 kV or pulsed charged by a hard-tube modulator with a variable repetition rate. The average power limit of the facility is 200 kW but this can be exceeded in a burst mode. A megavolt Marx generator is also available for single shot experiments. This paper discusses the facilities that support the switching experiments and presents some of the early test results.

Description of Facility

A simplified diagram of the facility is shown in figure 1. The incoming power is 200kW

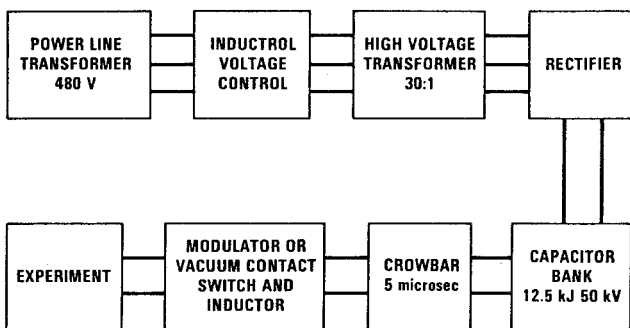

Figure 1. Facility Layout

average and the output is 50kV at 4 amps continuous. Higher currents can be achieved in a burst mode by drawing from the 12.5 kilojoule (10 microfarad) filter bank. The input voltage can be varied by an inductrol which is essentially a large variac. The transformer and rectifier charge the capacitor bank to 50 kV DC. Overloads are stopped by an ignitron crowbar which can respond in 5 microseconds. The high voltage to the experiment can be turned on and off by a vacuum contactor. The facility can be monitored and controlled from one screen room while a second screen room is reserved for the experimenter. Most of the information is handled by fiber optic links. Video cameras monitor the experiment and the facility. A command charge system is under construction which will allow the output pulse shape, amplitude and rep rate to be controlled directly with a floating deck vacuum tube modulator. This will replace the vacuum contactor in figure 1. A 12nF, 1.3 megavolt Marx bank is also available for single shot testing. A further description of the facility is in reference [1].

PFL

The facility includes a 100ns coaxial pulse forming line. The PFL consists of an 11 foot long outer aluminum conductor 11.25 inches inner diameter and two interchangeable inner conductors; one 3 inch diameter for an 8 ohm impedance and the other 10 inches for a 0.8 ohm impedance. Both center conductors fit the same end caps. The PFL is mounted on a Navy gun mount so that it can be rotated to different power sources or experiments. A diagram of the PFL is shown in fig 2. The dielectric is a deionized water-glycol mixture cooled to -60 F to provide decay time constants of 10s of milliseconds. The capacitance of the 0.8 ohm line is 100nF. In this configuration the PFL stores 500 joules at 100kV and provides a 200ns pulse to a liquid load. A one Henry inductor can be used to resonantly charge the PFL to 100kV in one millisecond. Smaller inductors can be used for faster charge times.

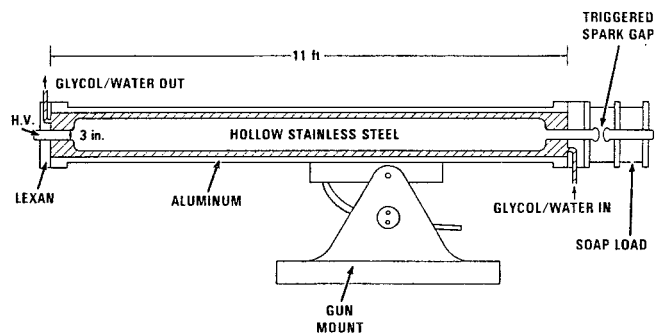

Figure 2. Water/Glycol PFL

Report Documentation Page

Form Approved
OMB No. 0704-0188

Public reporting burden for the collection of information is estimated to average 1 hour per response, including the time for reviewing instructions, searching existing data sources, gathering and maintaining the data needed, and completing and reviewing the collection of information. Send comments regarding this burden estimate or any other aspect of this collection of information, including suggestions for reducing this burden, to Washington Headquarters Services, Directorate for Information Operations and Reports, 1215 Jefferson Davis Highway, Suite 1204, Arlington VA 22202-4302. Respondents should be aware that notwithstanding any other provision of law, no person shall be subject to a penalty for failing to comply with a collection of information if it does not display a currently valid OMB control number.

1. REPORT DATE JUN 1987	2. REPORT TYPE N/A	3. DATES COVERED -	
4. TITLE AND SUBTITLE A Facility For High-Repetition-Rate Switch Testing At Medium Power		5a. CONTRACT NUMBER	
		5b. GRANT NUMBER	
		5c. PROGRAM ELEMENT NUMBER	
6. AUTHOR(S)		5d. PROJECT NUMBER	
		5e. TASK NUMBER	
		5f. WORK UNIT NUMBER	
7. PERFORMING ORGANIZATION NAME(S) AND ADDRESS(ES) Naval Surface Weapons Center, Dahlgren Laboratory Dahlgren, Va. 22448		8. PERFORMING ORGANIZATION REPORT NUMBER	
9. SPONSORING/MONITORING AGENCY NAME(S) AND ADDRESS(ES)		10. SPONSOR/MONITOR'S ACRONYM(S)	
		11. SPONSOR/MONITOR'S REPORT NUMBER(S)	
12. DISTRIBUTION/AVAILABILITY STATEMENT Approved for public release, distribution unlimited			
13. SUPPLEMENTARY NOTES See also ADM002371. 2013 IEEE Pulsed Power Conference, Digest of Technical Papers 1976-2013, and Abstracts of the 2013 IEEE International Conference on Plasma Science. Held in San Francisco, CA on 16-21 June 2013. U.S. Government or Federal Purpose Rights License			
14. ABSTRACT A one-ohm, 2.5 gigawatt, liquid-filled pulse forming line has been built which can be resonantly charged to 100kV in one millisecond, or pulsed charged at variable repetition rates. The facility average power is 200 kW but can exceed this in a burst mode. This paper describes the facilities to support switching experiments and some of the test results. One goal is to develop a high rep-rate spark gap without gas flow. Based on previous work, high pressure, light gases such as hydrogen will be needed as well as a "stiff" trigger to break down the gap well below D.C. The gas handling system can operate up to 70 atm. and includes flash arresters and emergency shutoffs. The triggering system uses a thyatron to discharge a capacitor through a transformer. Data is digitized locally and transferred optically for manipulation. The facility is set up to use optical diagnostics and interferometry.			
15. SUBJECT TERMS			
16. SECURITY CLASSIFICATION OF:			17. LIMITATION OF ABSTRACT SAR
a. REPORT unclassified	b. ABSTRACT unclassified	c. THIS PAGE unclassified	
			18. NUMBER OF PAGES 4
			19a. NAME OF RESPONSIBLE PERSON

Liquid Load

A switch and load can be placed on the end of the PFL in either a grounded switch or a grounded load configuration depending on the experimental requirements, (figure 3). The present loads are made from an Arm and Hammer laundry soap solution. A one ohm load can be made from about a liter of water. The resistivity of the soap solution is normally a function of concentration and temperature, but in the case of brass, aluminum and copper, it is also a function of the electric field applied. This variation of resistivity with electric field does not occur with stainless steel [2]. A plot of resistivity vs concentration for stainless is shown in figure 4. The temperature of the soap must be monitored if a large number of shots are fired.

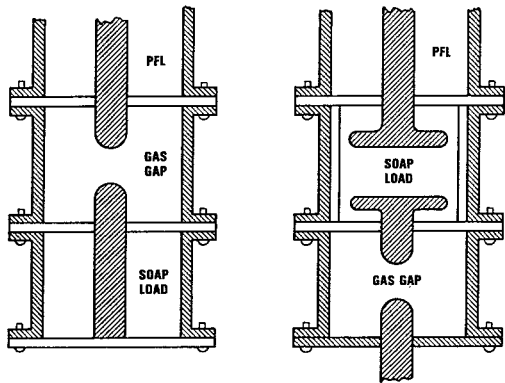

Figure 3. Switch/Load Configurations

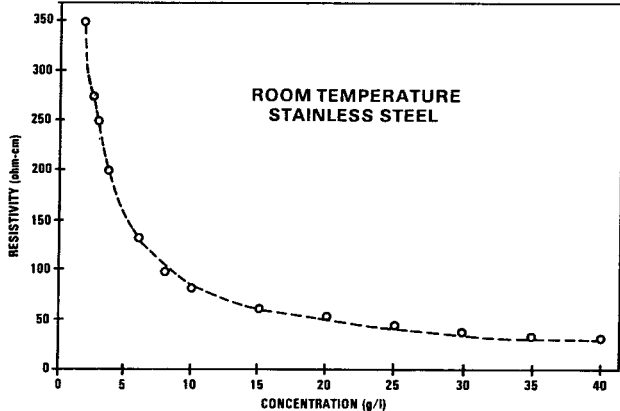

Figure 4. Soap Resistivity

Switch

Our experimental efforts are presently concentrating on high rep-rate spark gap switches, particularly high-pressure gas trigatron designs. The classic approach to achieving high rep rates is to flow the gases faster. While this will work even up through supersonic speeds [3], it creates problems from the standpoint of size, efficiency and complexity. We are trying to use the inherent recovery properties of the gas to minimize flow requirements. Our work on smaller spark gap switches has shown that light gases such as hydrogen exhibit faster recovery and that higher pressures also improve recovery [4].

Previous work has also shown that light gases have lower losses during the turn-on and conducting phases as well [5]. We have also demonstrated that strongly undervolting the gap improves recovery time [6]. Therefore the facility is being set up to handle high pressure hydrogen and to provide a strong or stiff trigger.

Gas Handling System

The gas handling system is shown in figure 5. Due to the explosive nature of hydrogen and the high pressures involved a number of safety features are incorporated. After the gas leaves the bottle it goes through an excess flow meter. If the gas flow exceeds a preset value such as a line rupture, the valve stops the gas flow. A solenoid cutoff provides a manual backup. The gas then goes through a flash arrestor to prevent an explosive flame front from

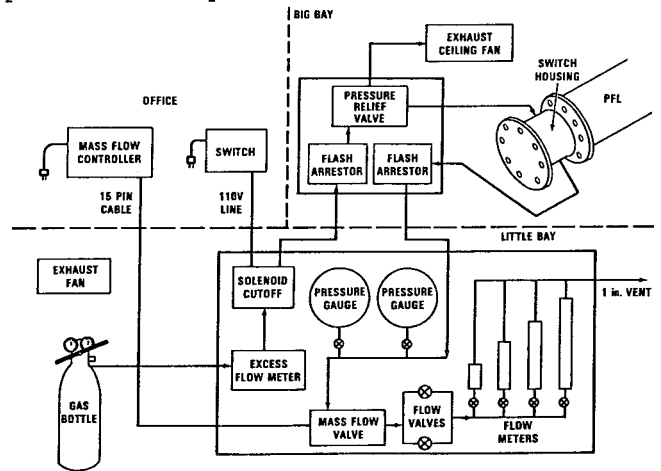

Figure 5. Gas Handling System

getting into the gas supply. Hose vented pressure relief valves are used to protect the switch housing from overpressure and a ceiling vent releases any gas escaping during housing disassembly. The gas lines then go to the switch housing and then to the pressure gauge and a mass flow controller. This controller measures the mass of hydrogen so that flow can be maintained regardless of pressure. Flow is maintained at a low rate to prevent long term buildup of deposits and to exchange gas between bursts. The gas then goes through flow valves, flow meters at atmospheric pressure and finally to a vent. The system is designed to operate at pressures up to 1,000 psig.

Triggering System

A high voltage resistive/capacitive probe measures the voltage across the input of the PFL and sends this information back to the screen room via fiber optic link. A comparator box in the screen room compares this voltage to a desired breakdown voltage which is dialed in by the operator. When the PFL voltage reaches the desired level, a signal is sent optically to the triggering system to fire the gap. One of the trigatron triggering systems is shown in figure 6. It consists of a D.C. power supply powering a 17kV thyratron that discharges a 10 nF capacitor through a 1:5 step-up transformer.

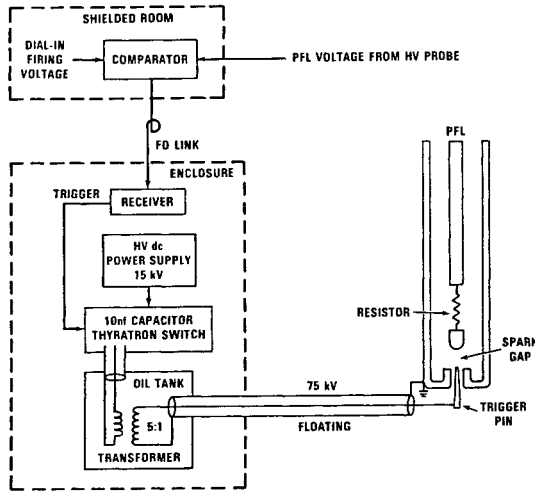

Figure 6. Triggering System

This produces a 75 kV triggering pulse with reversible polarity at rep rates of up to a kilohertz and risetimes of 100 ns. In situations where this trigger has inadequate risetime, voltage or currents, we have built a single shot trigger using a 100 kV D.C. supply charging a 100nF capacitor which is switched by a Maxwell triggered spark gap. This provides a 100kV, high current, 10ns rise pulse to provide a fast and powerful trigger but is limited to single shot. However, experiments on overvolted gaps at lower current indicate that in a high rep rate burst of pulses the recovery of the second pulse is indicative of the recovery of the rest of the pulses in the burst (see figure 7). Therefore, the recovery of the second pulse after being triggered by a single shot trigger should be a good indication of the recovery of the rest of the pulses in the burst.

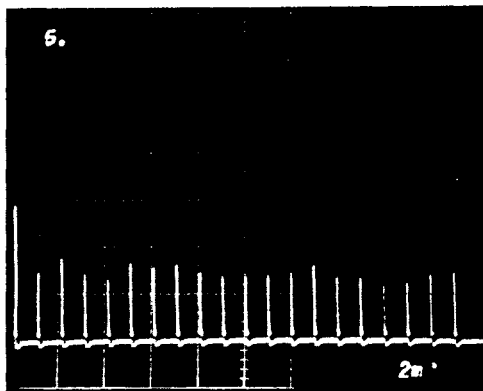

Figure 7. 20-pulse burst in hydrogen at 1kHz. 5 kV/div, 2msec/div

Diagnosics

The Net-11 program is available for circuit analysis. Charging waveforms for the millisecond resonant charge are presently monitored by an optically transmitted resistive divider. The frequency response of this device is 3 kHz. For the Marx generator, a capacitive divider is used at the input to

the PFL. Fast response capacitive probes and B dot loops are incorporated into the switch housings. A Tektronix R7912 transient digitizer in a shielded enclosure is located next to the PFL to minimize lead lengths. The fast current or voltage data is digitized and then transferred optically to the diagnostics screen room. A 5 by 10 foot optical table is beside the PFL so that the switch can be positioned over the table for optical experiments such as interferometry. CW and pulsed lasers are available as well as an OMA and spinning mirror and image converter cameras. Experiments are underway on lower power systems to look at shock wave energy, temperature profiles, and turbulence. An example of an interference pattern is shown in the sequence of spinning mirror photographs shown in figure 8. The heated region around the spark, the shock waves and the reflection of the shock off a barrier can be seen. The reflected shock wave does not disturb the heated region surrounding the original spark column indicating that the housing shape will not affect the recovery of the gap.

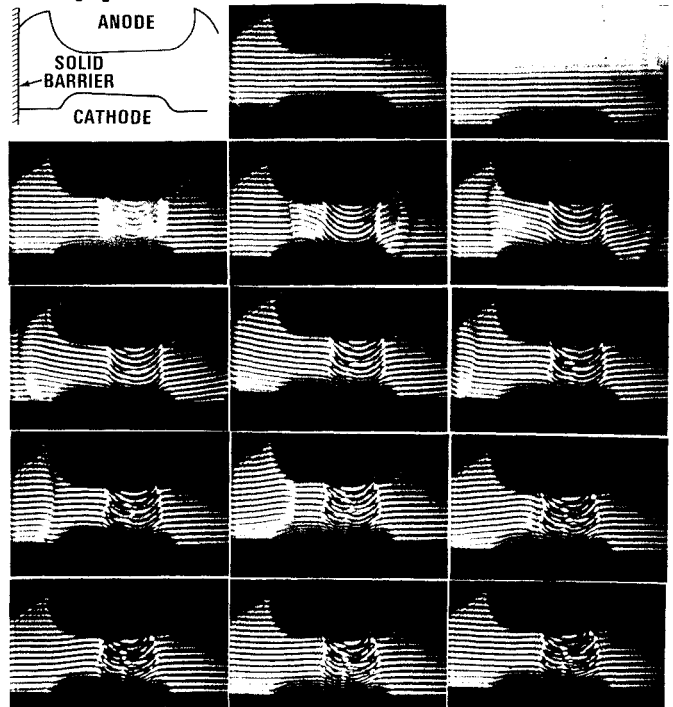

Figure 8. Spinning Mirror Pictures of a Spark in Air Showing Shock Wave Reflecting Off a Flat Barrier. 8 microsec/frame.

Spark Gap Housings

Figure 9 shows a spark gap housing that has been constructed to allow a number of experiments to be performed. The same switch can be used for either the grounded switch or the grounded load configurations. The spacing for both the main gap and the trigger pin are variable as is the trigger pin shape and the electrode material. Four 3 cm optical windows and 3 cm diameter electrodes allow a large viewing area for optical diagnostics. The housing can withstand up to 200 psig pressure. Figure 10 shows another spark gap housing designed to withstand 1000 psig. The electrodes and trigger pin are removable and are made from elkonite to reduce erosion. The Jason electric field code is available to

predict stress points. An example of a field plot for figure 10 is shown in figure 11.

The facility and the PFL will provide these switches with a 50kA, 100kV burst of 10 pulses at rep rates of a kilohertz or greater. Previous work at a few hundred amps has demonstrated recovery times of 100 microseconds in light gases with undervolted gaps [6]. Some of the first tests on the PFL will be to see if this recovery can be extended to the kiloamp regime. A comparison of the literature on recovery times in air (figure 12) shows that varying the current by a factor of 1,000 does not drastically affect the recovery time. It is hoped that the current affects in high pressure undervolted hydrogen will be similar. Rep-rated switch testing is presently underway.

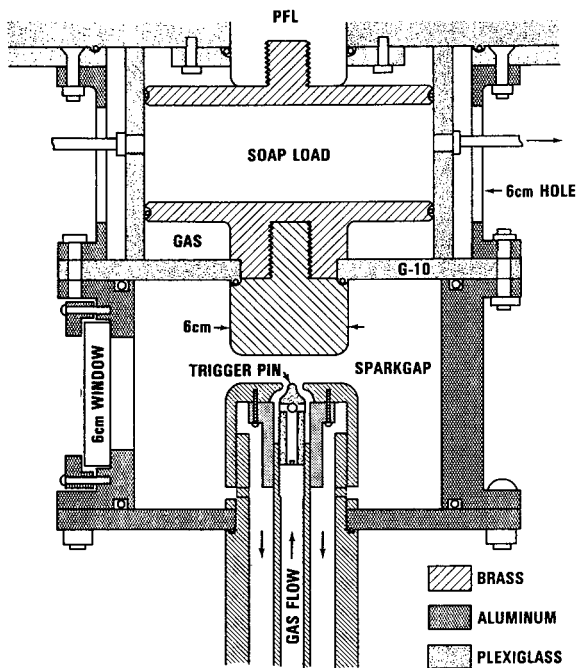

Figure 9. Large-Window Spark Gap in Grounded Switch Configuration.

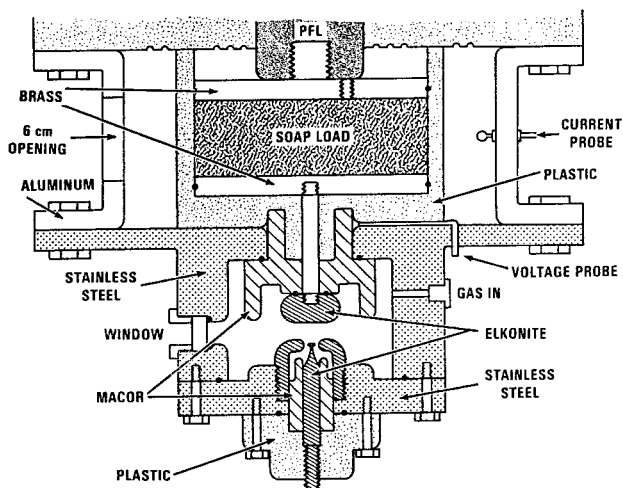

Figure 10. High-Pressure Spark Gap and Load.

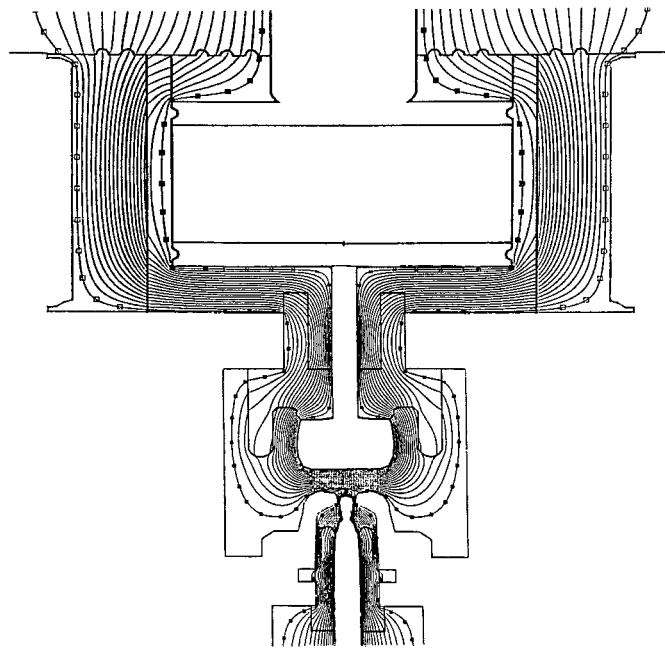

Figure 11. Jason Plot of Figure 10.

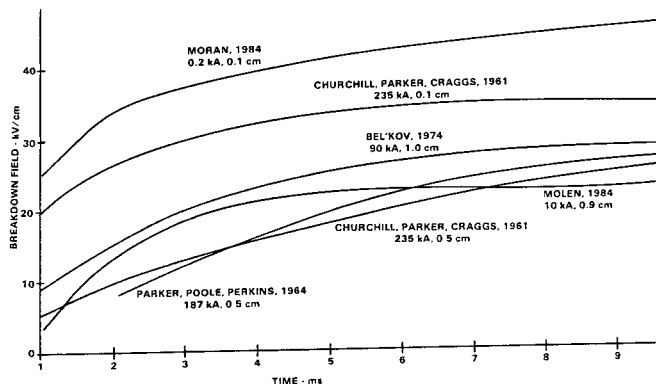

Figure 12. Recovery of Air at atmospheric pressure for currents from 200 A to 235 kA. Copper or brass electrodes.

References

- [1] T.L.Berger, V.H.Gehman, D.D.Lindberg, R.J. Gripshover, "A 2.5 Gigawatt Liquid Dielectric Coaxial Pulse Forming Line" 6th IEEE Pulse Power Conf., June 1987
- [2] L.E.Martinez, Sandia internal report to be published
- [3] M.S.Mazzola, G.M.Molen, J.M.Kuhlman, "Overvoltage effects on the Recovery of a Gas Blown Spark Gap", 6th IEEE Pulse Power Conf., June 1987
- [4] S.Moran, S.Hairfield, "Recovery of Overvolted Spark Gaps", 16th Power Modulator Symposium, June 1984
- [5] W.D.Kimura, M.J.Kushner, E.A.Crawford, S.A. Byron, "Voltage and Current Measurements of a Laser Preionization Triggered High Voltage Switch" 5th IEEE Pulse Power Conf. June 1985
- [6] R.K.Hutcherson, S.L.Moran, "Triggered Spark Gap Recovery" 6th IEEE Pulse Power Conf. June 1987